

## Aspects regarding the Use of Hydraulic Motors

Prof. PhD. math. **Alexandru BOBE**<sup>1</sup>, PhD. Eng. **Tiberiu AXINTE**<sup>2,\*</sup>, PhD. Eng. **Cătălin NUȚU**<sup>3</sup>,  
Dipl. Eng. **Cătălin FRĂȚILĂ**<sup>2</sup>, Dipl. Eng. **Mihai DIACONU**<sup>2</sup>

<sup>1</sup> Ovidius University of Constanta, Romania

<sup>2</sup> Research and Innovation Center for Navy, Romania

<sup>3</sup> Constanta Maritime University, Romania

\*tibi\_axinte@yahoo.com

**Abstract:** This article represents research regarding use of hydraulic motors. The role of hydraulic motors is to convert fluid pressure into rotary motion. The motor considered in this article is a hydraulic actuator. The hydraulic motor works only with a pump unit. A pump unit usually has a maxim pressure of  $6 \cdot 10^5$  Pa. Hydraulic motors can be used for various applications, such as: excavators, shredders, drilling rigs, winches, crane drives, cooling fan drivers, feeder, roll mills, launch and recovery systems (LARS), etc. After introduction, the authors study two pneumatic circuits using hydraulic motors. The first one has only one device (hydraulic motor 1-1). The second one has two such devices (hydraulic motors 2-1 and 2-2). Afterwards, the two corresponding electro-hydraulic schemes are presented: a simple electro-hydraulic scheme that has only one hydraulic motor and the second electro-hydraulic scheme, which has a hydraulic motor and logic module. The hydraulic and electro-hydraulic schemes given in this paper are designed using FluidSim software from Festo.

**Keywords:** Actuator, hydraulic, shaft, valve, circuit

### 1. Introduction

A hydraulic motor is a device that converts hydraulic pressure or flow into angular displacement (rotation) and torque. The first hydraulic motor was constructed by Arthur Rigg in 1885. However, over time, hydraulic motors have developed a lot from a constructive point of view.

Likewise, the hydraulic motors used in the research ship's installations are a mechanical actuator. This actuator converts hydraulic pressure and flow into angular displacement and torque.

At present, these hydraulic actuators can be used in many technical fields.

They are used especially in any application requiring rotational force (torque), [1].

In practice, there are various models of hydraulic motors: vane motors, gear motors, gerotor motors, radial piston motors, internal curved plunger motors and axial piston motors.

In terms of revolving speed, the hydraulic motors can be: low-speed and high-speed motors, [2].

The hydraulic motors have a compact structure and stability in movement, Fig. 1.



Fig. 1. Hydraulic motor

The main operating specifications to be considered for hydraulic motors:

- Operating temperature – the fluid temperature range the motor can accommodate;
- Operating torque – the torque motor is capable to deliver. Operating torque is directly proportional to the pressure of the working fluid delivered to the hydraulic motor;
- Operating speed – the rotation speed of the moving parts of the hydraulic motors. Operating speed is expressed in radian per second (1 rad/s), according to the International Systems of Units (SI);
- Operating pressure – the pressure of the working fluid delivered to the hydraulic motor. The working pressure directly affects operating torque, engine power, flow and speed, [3].

The power of the hydraulic motor depends on the flow rate and pressure of the fluid passing through actuator.

The hydraulic motor that is an actuator is represented by a specific standard symbol, Fig. 2.

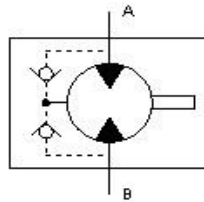

**Fig. 2.** Symbol of hydraulic motor

Pascal's law is defined as a changed pressure of a fluid in any of its point transmitted undiminished to all point in that fluid.

This principle is valid also for the hydraulic motor, [3].

The relation of the Pascal's principle is:

$$\Delta p = \Delta h \cdot g \cdot \rho \quad (1)$$

Where:

- $\Delta p$  – the difference in pressure at two different points within a fluid column;
- $\Delta h$  – the difference in elevation between the two points within the fluid column;
- $g$  – the acceleration due to gravity;
- $\rho$  – the fluid density.

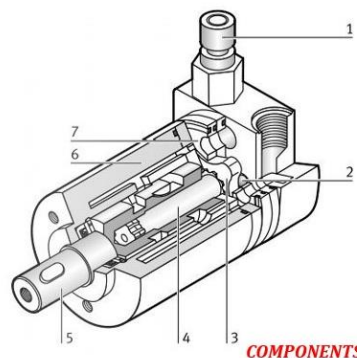

**Fig. 3.** Components of hydraulic motor

Main components of a hydraulic motor, Fig. 3:

- 1) Ports;
- 2) Shuttle valve;
- 3) Gear with external teeth;
- 4) Cardan shaft;
- 5) Working shaft with collector piece;
- 6) Housing with pilot ducts;
- 7) Stationary gear with internal gear teeth.

**2. The hydraulic circuits**

The pneumatic scheme with only one hydraulic motor has a very simple design. A hydraulic motor using this pneumatic circuit is often used in areas of extreme temperatures due to safety of using air rather than electricity or hazardous chemicals. In fact, the installation with this hydraulic motor is an affordable option regarding costs, [4]. The following hydraulic circuit presented in this manuscript operates only when to 4/3 way fluid directional valve will be given a manual command. First hydraulic scheme has only one hydraulic motor 1-1, Fig. 4.

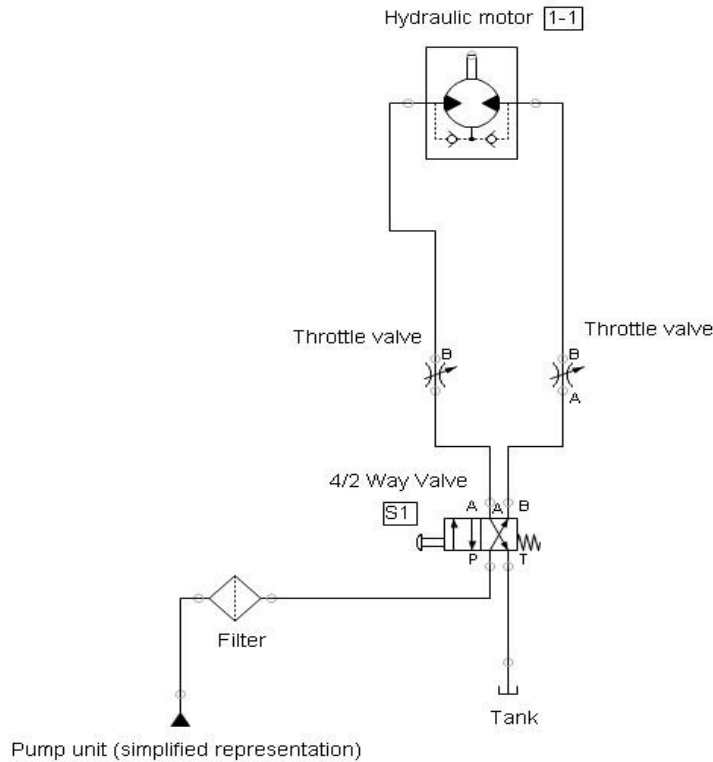

**Fig. 4.** First hydraulic circuit using one actuator

In the table below there are seven devices used in this first hydraulic scheme, Table 1.

**Table 1:** Devices in the first hydraulic scheme

Description	Number of components
Hydraulic motor 1-1	1
Throttle valve	2
4/2 way valve with spring	1
Filter	1
Pump unit (simplified representation)	1
Tank	1

This first hydraulic circuit operates if operator presses S1 button of the 4/2 way directional valve with spring. Then, the working shaft rotates clockwise. After that, the working shaft returns, because the 4/2 way directional valve has a spring causing this return, Fig. 5.

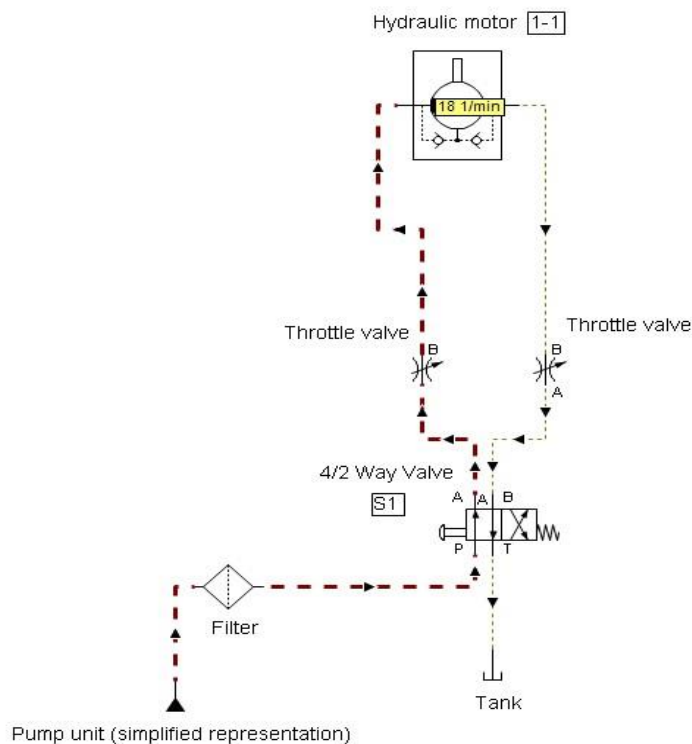

**Fig. 5** First hydraulic circuit using one actuator

The diagrams given show variation of the following functional parameters of the hydraulic motor 1-1: revolution (rpm) and flow rate (q), Fig. 6.

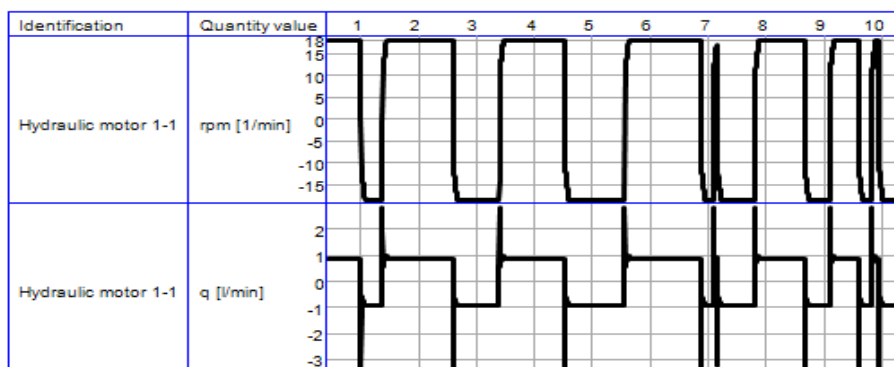

**Fig. 6.** Diagrams of functional parameters variations of the hydraulic motor

Besides the relation of flow rate for hydraulic motors is:

$$q = \frac{D \cdot n}{1000 \cdot \eta_v} r^2 \tag{2}$$

Where:

- q – flow rate;
- D – displacement;
- n – shaft speed;
- $\eta_v$  – volumetric efficiency.

The second hydraulic scheme studied has two symmetric actuators: hydraulic motor 2-1 and hydraulic motor 2-2, Fig. 7.

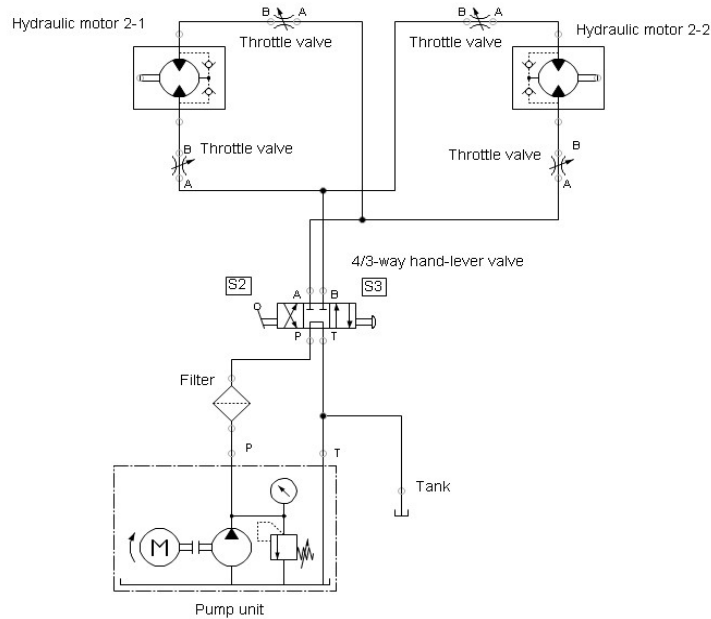
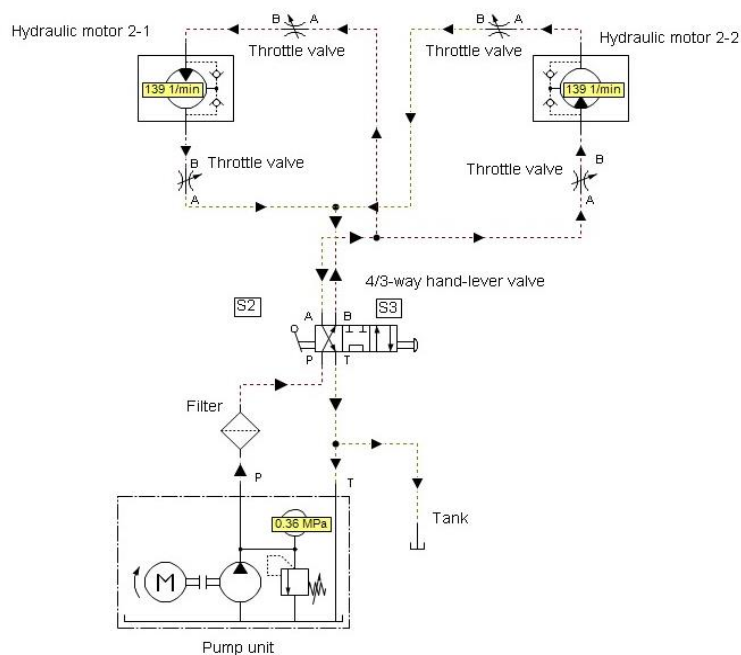

**Fig. 7.** Second hydraulic circuit using two actuators

In the table below there are ten devices used in the second hydraulic scheme, Table 2.

**Table 2:** Devices in the second hydraulic circuit

Description	Number of components
Hydraulic motor 2-1	1
Hydraulic motor 2-2	1
Throttle valve	4
4/3 way hand-level valve with button	1
Filter	1
Pump unit	1
Tank	1



**Fig. 8.** Simulation of the second hydraulic circuit

In this case, the operator pushes the S2 lever to start the second hydraulic circuit. However, in order to close the same second hydraulic circuit, the S3 button has to be pressed, Fig. 8.

**3. The electro-hydraulic circuits**

Electro-hydraulic circuits using hydraulic motors are more complex than hydraulic circuits using the same actuators.

The main advantages of electro-hydraulic circuits using hydraulic motors are: easy motion control, excellent resistance to vibrations, high power density, simple thermal exchange management, capability of absorbing impulsive loads, [5].

First electro-circuit has only one hydraulic motor 3-1. The first electro-hydraulic scheme comprises a few basic hydraulic and electrical devices. It must be noted that the authors used a latched 4/3 – way solenoid valve, having “memory”. This “memory” has an effect on commands given by the operator of this hydraulic installation, Fig. 9.

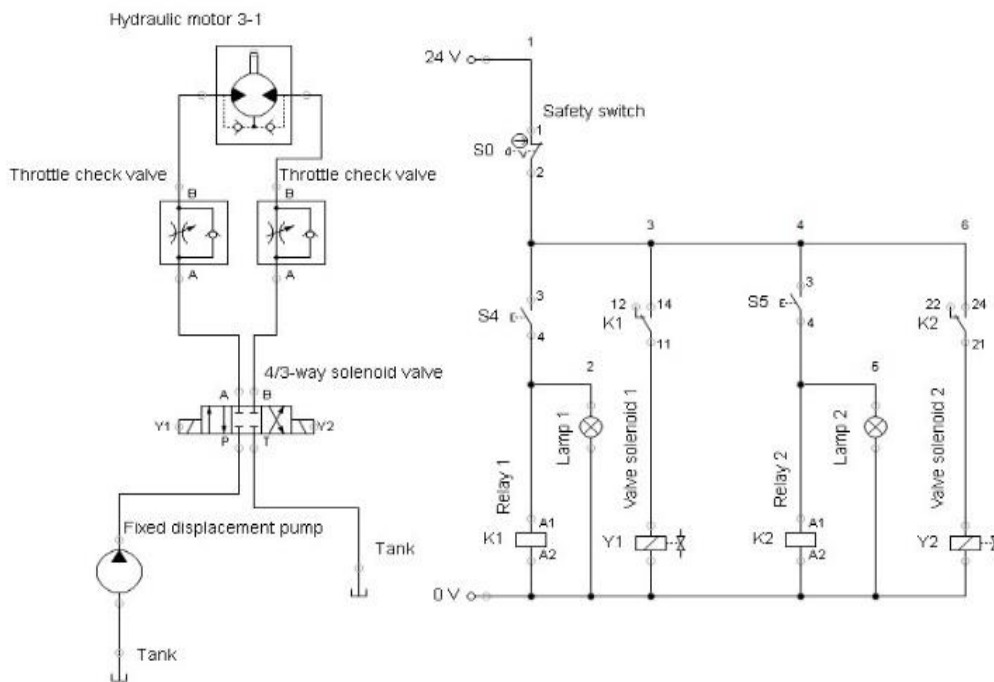

**Fig. 9.** First electro-hydraulic circuit

In the table below there are fourteen devices used in the first electro-hydraulic circuit, Table 3.

**Table 3:** Devices in the first electro-hydraulic circuit

Description	Number of components
Hydraulic motor 3-1	1
Throttle check valve	2
4/3 way solenoid valve	1
Fixed displacement pump	1
Tank	2
Safety switch	1
Relay	2
Valve solenoid	2
Lamp	2

In order to operate the electro-hydraulic circuit having one hydraulic motor 3-1, the operator has to press S4 button.

Then, the working shaft rotates clockwise and lamp 1 shows a yellow signal, Fig. 10.

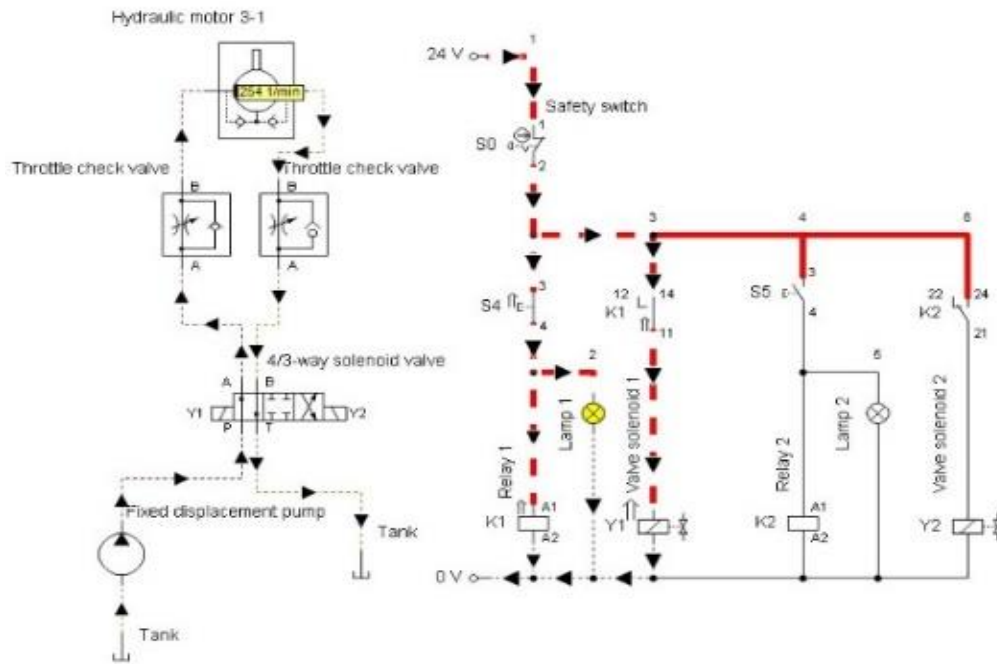

Fig. 10. Opening the first electro-hydraulic circuit. Simulation I

In order to close the first electro-hydraulic circuit, operator has to press the S5 button. Then, working shaft rotates counterclockwise and lamp 2 shows a green signal, Fig. 11.

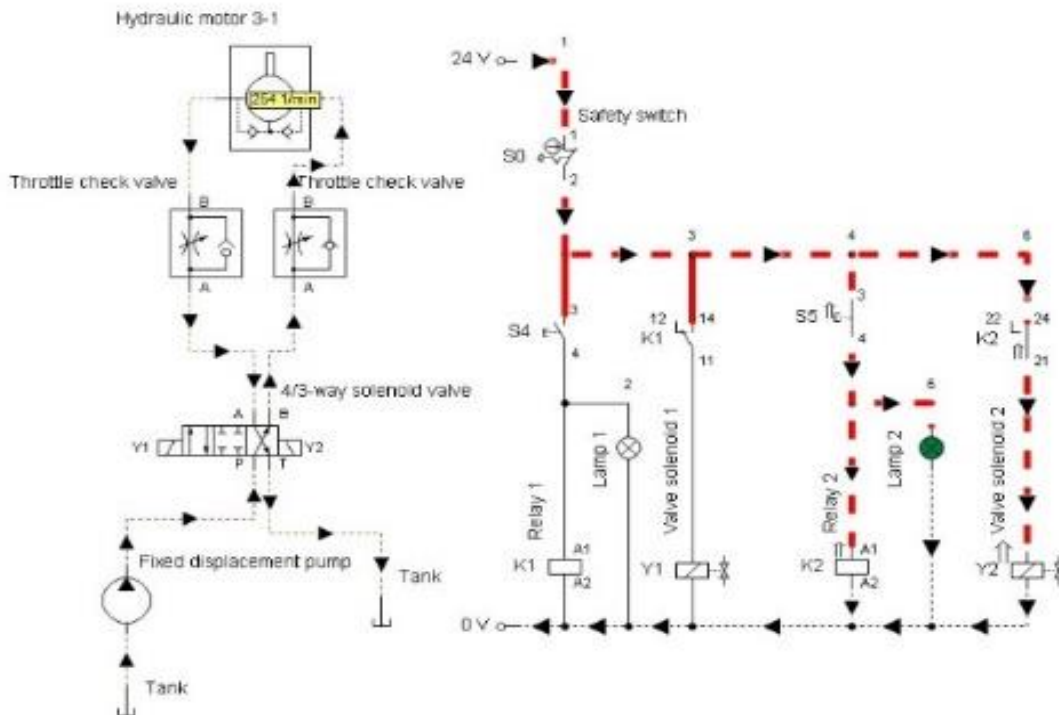

Fig. 11. Closing the first electro-hydraulic circuit. Simulation II

Another further improvement for the scheme presented above is to use a logic module. Which also offers much more flexibility in controlling the hydraulic motor 4-1, using a variable displacement pump, Fig. 12.

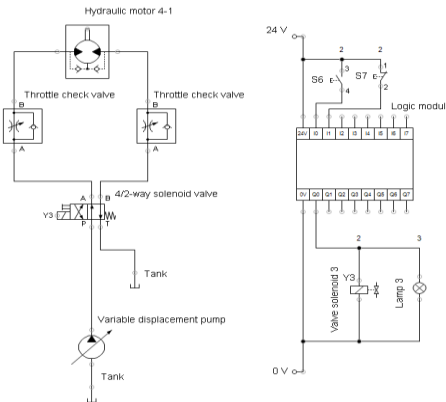

Fig. 12. Second electro-hydraulic circuit using digital module

In the table below there are eleven devices used in the second electro-hydraulic circuit, Table 4.

Table 4: Devices in the second electro-hydraulic scheme

Description	Number of components
Hydraulic motor 4-1	1
Throttle check valve	2
4/2 way solenoid valve	1
Variable displacement pump	1
Tank	2
Logic module	1
Valve solenoid	2
Lamp	1

The next two figures show the movement of the hydraulic motor 4-1, [6].

Thus, in order to open the second electro-hydraulic circuit, operator must press S6 button.

In this case, the working shaft of hydraulic motor 4-1 rotates counterclockwise and lamp shows a blue signal, Fig. 13.

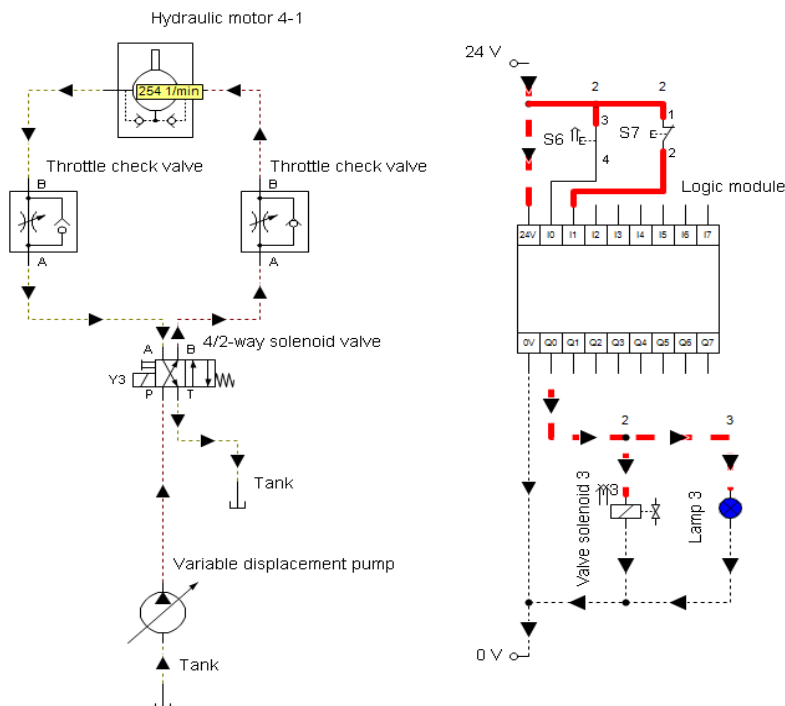

Fig. 13. Opening the second-hydraulic circuit using a logic module. Simulation I



However, in order to close the second electro-hydraulic circuit, operator should press S7 button. Now, the working shaft of hydraulic motor rotates clockwise, Fig. 14.

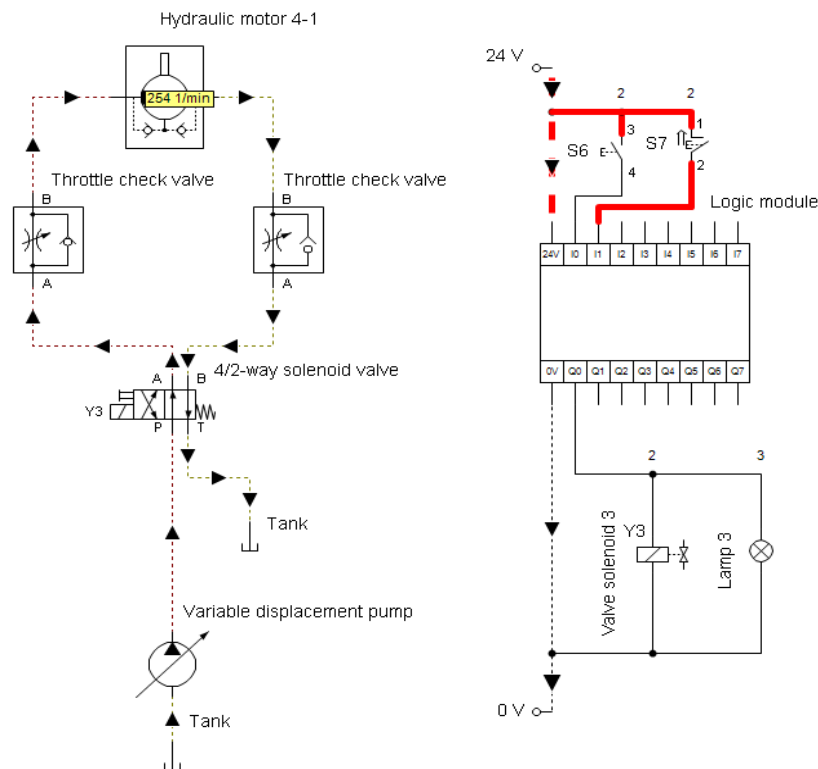

Fig. 14. Closing the second-hydraulic circuit using a logic module. Simulation II

#### 4. Conclusions

Taking into consideration all what has been presented in this paper, the electro-hydraulic circuits using hydraulic motors offer some important advantages over traditional electro-hydraulic scheme using other devices (semi-rotary, single acting cylinder, double acting cylinder, etc.).

These advantages are:

- they run only when needed;
- installations using them are very smooth and quiet;
- self-containment and compactness;
- these installations do not leak;
- these installations use a DC power supply.

Given their superior strength, it seems hydraulic motors will replace in time, in some applications, the hydraulic cylinders from electro-hydraulics installations. Because each product development generates its own individual challenges, it would be however, a nonsense to claim that hydraulic motors could be a complete substitute for a hydraulic device from electro-hydraulic installations.

Depending on the particular installations and specific technical applications, other technical solutions replacing use of hydraulic motors are also possible. To make a correct economical and technical decision in this direction, all aspects involved, such as costs of acquisition, operational costs also including energy costs, strength and resistance to specific mechanical stresses, maintenance and reliability are to be taken into consideration.

Hydraulic actuators however offer some unique features, which are to be explored especially to winches and cranes from ships.

Researches and operators should be encouraged to take into account a hydraulic motor when searching for a suitable fluid movement device in electro-hydraulic installations.

A more sophisticated electro-hydraulic circuits with hydraulic motors and programmable logic controller (PLC) is to be developed in future article to be submitted.

**References**

- [1] Surdu, G. “Sustainable development a challenge for research in the field military equipment and space.” *Impact of Socio-economic and Technological Transformations at National, European and International Level (ISETT)* 7 (2015).
- [2] Deleanu, D., and C. L. Dumitrache. “Numerical study of a container ship model for the uncoupled parametric rolling.” *IOP Conference Series: Materials Science and Engineering* 591 (2019): 012106.
- [3] Nastasescu, V., and L. Gavrilă. “Controlled flow simulation using SPH method.” Paper presented at the International Conference of Scientific Paper AFASES, Brasov, Romania, May 24-26, 2012.
- [4] Hruzik, L., A. Burecek, L. Dvorak, K. Fojtasek, P. Monka, M. Vasina, and M. Bova. “Valve control of drive with rotary hydraulic motor.” *MM Science Journal* (June 2019): 2902- 2909.
- [5] Panaitescu, M., and F. V. Panaitescu. “Consideration on Hydraulic Modelling and Evaluation of Surface Waters with Environmental Risk.” *Hidraulica Magazine*, no. 4 (December 2020): 59-71.
- [6] Thiagarajan, D., and N. Manoharan. “Adapting concurrent engineering approach for design and development of a new rotary hydraulic motor for marine application.” *ARPJ Journal of Engineering and Applied Sciences* 10, no. 13 (July 2015): 5564- 5568.