

Rules and Regulations for the Classification of Ships

January 2016

© Lloyd's Register Group Limited 2016. All rights reserved.

Except as permitted under current legislation no part of this work may be photocopied, stored in a retrieval system, published, performed in public, adapted, broadcast, transmitted, recorded or reproduced in any form or by any means, without the prior permission of the copyright owner. Enquiries should be addressed to Lloyd's Register Group Limited, 71 Fenchurch Street, London, EC3M 4BS.

Rules and Regulations for the Classification of Ships

January 2016

A guide to the Rules

and published requirements

Rules and Regulations for the Classification of Ships

Introduction

The Rules are published as a complete set; individual Parts are, however, available on request. A comprehensive List of Contents is placed at the beginning of each Part.

Rules updating

The Rules are generally published annually and changed through a system of Notices between releases.

Rules programs

LR has developed a suite of Calculation Software that evaluates Requirements for Ship Rules, Offshore Rules, Special Service Craft Rules and Naval Ship Rules. For details of this software please contact LR.

Direct calculations

The Rules may require direct calculations to be submitted for specific parts of the ship structure or arrangements and these will be assessed in relation to LR's own direct calculation procedures. They may also be required for ships of unusual form, proportion or speed, where intended for the carriage of special cargoes or for special restricted service and as supporting documentation for arrangements or scantlings alternative to those required by the Rules.

January 2016

Lloyd's Register is a trading name of Lloyd's Register Group Limited and its subsidiaries. For further details please see <http://www.lr.org/entities>

Lloyd's Register Group Limited, its subsidiaries and affiliates and their respective officers, employees or agents are, individually and collectively, referred to in this clause as 'Lloyd's Register'. Lloyd's Register assumes no responsibility and shall not be liable to any person for any loss, damage or expense caused by reliance on the information or advice in this document or howsoever provided, unless that person has signed a contract with the relevant Lloyd's Register entity for the provision of this information or advice and in that case any responsibility or liability is exclusively on the terms and conditions set out in that contract.

CLASSIFICATION

PART	1	REGULATIONS
PART	2	RULES FOR THE MANUFACTURE, TESTING AND CERTIFICATION OF MATERIALS
PART	3	SHIP STRUCTURES (GENERAL)
PART	4	SHIP STRUCTURES (SHIP TYPES)
PART	5	MAIN AND AUXILIARY MACHINERY
PART	6	CONTROL, ELECTRICAL, REFRIGERATION AND FIRE
PART	7	OTHER SHIP TYPES AND SYSTEMS
PART	8	RULES FOR ICE AND COLD OPERATIONS

The following explanatory note is offered to assist those concerned in the application of these Rules and Regulations.

Explanatory Note

Ship classification may be regarded as the development and worldwide implementation of published Rules and Regulations which, in conjunction with proper care and conduct on the part of the Owner and operator, will provide for:

- (a) the structural strength of (and where necessary the watertight integrity of) all essential parts of the hull and its appendages;
- (b) the safety and reliability of the propulsion and steering systems; and
- (c) the effectiveness of those other features and auxiliary systems which have been built into the ship in order to establish and maintain basic conditions on board whereby appropriate cargoes and personnel can be safely carried whilst the ship is at sea, at anchor, or moored in harbour.

Lloyd's Register (LR) maintains these provisions by way of the periodical visits by its Surveyors to the ship as defined in the Regulations in order to ascertain that the vessel currently complies with those Rules and Regulations. Should significant defects become apparent or damages be sustained between the relevant visits by the Surveyors, the Owner and operator are required to inform LR without delay. Similarly any modification which would affect Class must receive prior approval by LR.

A ship is said to be in Class when the Rules and Regulations which pertain to it have, in the opinion of LR, been complied with, or when special dispensation from compliance has been granted by LR.

It should be appreciated that, in general, classification Rules and Regulations do not cover such matters as the ship's floatational stability, life-saving appliances, and structural fire protection, detection and extinction arrangements where these are covered by the *International Convention for the Safety of Life at Sea, 1974, its Protocol of 1978*, and the amendments thereto. Nor do they cover pollution prevention arrangements where these are covered by the *International Convention for the Prevention of Pollution from Ships, 1973, its protocol of 1978*, and the amendments thereto. Nor do they protect personnel on board from dangers connected with their own actions or movement around the ship. This is because the handling of these aspects is the prerogative of the National Authority with which the ship is registered. A great many of these authorities, however, delegate such responsibilities to the Classification Societies who then undertake them in accordance with agreed procedures.

		CLASSIFICATION
PART	1	REGULATIONS
		CHAPTER 1 GENERAL REGULATIONS
		CHAPTER 2 CLASSIFICATION REGULATIONS
		CHAPTER 3 PERIODICAL SURVEY REGULATIONS
PART	2	RULES FOR THE MANUFACTURE, TESTING AND CERTIFICATION OF MATERIALS
PART	3	SHIP STRUCTURES (GENERAL)
PART	4	SHIP STRUCTURES (SHIP TYPES)
PART	5	MAIN AND AUXILIARY MACHINERY
PART	6	CONTROL, ELECTRICAL, REFRIGERATION AND FIRE
PART	7	OTHER SHIP TYPES AND SYSTEMS
PART	8	RULES FOR ICE AND COLD OPERATIONS

Section

- 1 **Background**
- 2 **Governance**
- 3 **Technical Committee**
- 4 **Naval Ship Technical Committee**
- 5 **Applicability of Classification Rules and Disclosure of Information**
- 6 **Ethics**
- 7 **Non-Payment of Fees**
- 8 **Limits of Liability**

■ *Section 1*
Background

1.1 Lloyd's Register Group Limited is a registered company under English law, with origins dating from 1760. It was established for the purpose of producing a faithful and accurate classification of merchant shipping. It now primarily produces classification Rules.

1.2 Classification services are delivered to clients by a number of other members subsidiaries and affiliates of Lloyd's Register Group Limited, including but not limited to: Lloyd's Register EMEA, Lloyd's Register Asia, Lloyd's Register North America, Inc., and Lloyd's Register Central and South America Limited. Lloyd's Register Group Limited, its subsidiaries and affiliates are hereinafter, individually and collectively, referred to as 'LR'.

■ *Section 2*
Governance

2.1 Lloyd's Register Group Limited is managed by a Board of Directors (hereinafter referred to as 'the Board').

The Board has:

appointed a Classification Committee and determined its powers and functions and authorised it to delegate certain of its powers to a Classification Executive and Devolved Classification Executives;

appointed Technical Committees and determined their powers, functions and duties.

2.2 LR has established National and Area Committees in the following:

Countries:	Areas:
Australia (via Lloyd's Register Asia)	Benelux (via Lloyd's Register EMEA)
Canada (via Lloyd's Register North America, Inc.)	Central America (via Lloyd's Register Central and South America Ltd)
China (via Lloyd's Register Asia)	Nordic Countries (via Lloyd's Register EMEA)
Egypt (via Lloyd's Register EMEA)	South Asia (via Lloyd's Register Asia)
Federal Republic of Germany (via Lloyd's Register EMEA)	Asian Shipowners (via Lloyd's Register Asia)
France (via Lloyd's Register EMEA)	Greece (via Lloyd's Register EMEA)
Italy (via Lloyd's Register EMEA)	

Japan (via Lloyd's Register Group Limited)
 New Zealand (via Lloyd's Register Asia)
 Poland (via Lloyd's Register (Polska) Sp zoo)
 Spain (via Lloyd's Register EMEA)
 United States of America (via Lloyd's Register North America, Inc.)

■ *Section 3* **Technical Committee**

3.1 LR's Technical Committee is at present composed of a maximum of 80 members which includes:

Ex officio members:

- Chairman and Chief Executive Officer of Lloyd's Register Group Limited
- Chairman of the Classification Committee of Lloyd's Register Group Limited

Members Nominated by:

- Technical Committee
- Professional bodies representing technical disciplines relevant to the industry
- National and International trade associations with competence relevant to technical issues related to LR's business

3.2 In addition to the foregoing:

- (a) Each National or Area Committee may appoint a representative to attend meetings of the Technical Committee.
- (b) A maximum of five further representatives from National Administrations may be co-opted to serve on the Technical Committee. Representatives from National Administrations may also be elected as members of the Technical Committee as Nominated Members
- (c) Further persons may be co-opted to serve on the Technical Committee by the Technical Committee.

3.3 All elections are subject to confirmation by the Board.

3.4 The function of the Technical Committee is to consider:

- (a) any technical issues connected with LR's business;
- (b) any proposed alterations in the existing Rules;
- (c) any new Rules for classification;

Where changes to the Rules are necessitated by mandatory implementation of International Conventions and Codes, or Common Rules, Unified Requirements and Interpretations adopted by the International Association of Classification Societies, these may be implemented by LR without consideration by the Technical Committee, although any such changes will be provided to the Technical Committee for information.

Where changes to the Rules are required by LR to enable existing technical requirements within the Rules to be recognised as Class Notations or Descriptive Notes, these may be implemented by LR without consideration by the Technical Committee, although any such changes will be provided to the Technical Committee for information.

3.5 The term of office of the Chairman and of all members of the Technical Committee is five years. Members may be re-elected to serve an additional term of office with the approval of the Board. The term of office of the Chairman may be extended with the approval of the Board.

3.6 In the case of continuous non-attendance of a member, the Technical Committee may withdraw membership.

3.7 Meetings of the Technical Committee are convened as often and at such times and places as is necessary, but there is to be at least one meeting in each year. Urgent matters may be considered by the Technical Committee by correspondence.

3.8 Any proposal involving any alteration in, or addition to the General Regulations, of Rules for Classification is subject to approval of the Board. All other proposals for additions to or alterations to the Rules for Classification other than the General

Regulations, will following consideration and approval by the Technical Committee either at a meeting of the Technical Committee or by correspondence, be recommended to the Board for adoption.

3.9 The Technical Committee is empowered to:

- (a) appoint sub-Committees or panels; and
- (b) co-opt to the Technical Committee, or to its sub-Committees or panels, representatives of any organisation or industry or private individuals for the purpose of considering any particular problem.

■ *Section 4* **Naval Ship Technical Committee**

4.1 LR's Naval Ship Technical Committee is at present composed of a maximum of 50 members and includes:

Ex officio members:

- Chairman and Chief Executive Officer of Lloyd's Register Group Limited

Member nominated by:

- Naval Ship Technical Committee;
- The Royal Navy and the UK Ministry of Defence;
- UK Shipbuilders, Ship Repairers and Defence Industry;
- Overseas Navies, Governments and Governmental Agencies;
- Overseas Shipbuilders, Ship Repairers and Defence Industries;

4.2 All elections are subject to confirmation by the Board.

4.3 All members of the Naval Ship Technical Committee are to hold security clearance from their National Authority for the equivalent of NATO CONFIDENTIAL. All material is to be handled in accordance with NATO Regulations or, for non-NATO countries, an approved equivalent. No classified material shall be disclosed to any third party without the consent of the originator.

4.4 The term of office of the Naval Ship Technical Committee Chairman and of all members of the Naval Ship Technical Committee is five years. Members may be re-elected to serve an additional term of office with the approval of the Board. The term of the Chairman may be extended with the approval of the Board.

4.5 In the case of continuous non-attendance of a member, the Naval Ship Technical Committee may withdraw membership.

4.6 The function of the Naval Ship Technical Committee is to consider technical issues connected with Naval Ship matters and to approve proposals for new Naval Ship Rules, or amendments to existing Naval Ship Rules. Where appropriate, Naval Ship Technical Committee may also recognise alternative LR Rule requirements that have been approved by the other Lloyd's Register Technical Committee as adjunct to the Naval Ship Rules.

4.7 Meetings of the Naval Ship Technical Committee are convened as necessary but there will be at least one meeting per year. Urgent matters may be considered by the Naval Ship Technical Committee by correspondence.

4.8 Any proposal involving any alteration in, or addition to, the General Regulations of Rules for Classification of Naval Ships is subject to approval of the Board. All other proposals for additions to or alterations to the Rules for Classification of Naval Ships, other than the General Regulations, will following consideration and approval by the Naval Ship Technical Committee, either at a meeting of the Naval Ship Technical Committee or by correspondence, be recommended to the Board for adoption.

4.9 The Naval Ship Technical Committee is empowered to:

- (a) appoint sub-Committees or panels; and
- (b) co-opt to the Naval Ship Technical Committee, or to its sub-Committees or panels, representatives of any organisation or industry or private individuals for the purpose of considering any particular problem.

■ Section 5**Applicability of Classification Rules and Disclosure of Information**

5.1 LR has the power to adopt, and publish as deemed necessary, Rules relating to classification and has (in relation thereto) provided the following:

- (a) Except in the case of a special directive by the Board, no new Regulation or alteration to any existing Regulation relating to classification or to class notations is to be applied to existing ships.
- (b) Except in the case of a special directive by the Board, or where changes necessitated by mandatory implementation of International Conventions, Codes or Unified Requirements adopted by the International Association of Classification Societies are concerned, no new Rule or alteration in any existing Rule is to be applied compulsorily after the date on which the contract between the ship builder and shipowner for construction of the ship has been signed, nor within six months of its adoption. The date of 'contract for construction' of a ship is the date on which the contract to build the ship is signed between the prospective shipowner and the ship builder. This date and the construction number (i.e. hull numbers) of all the vessels included in the contract are to be declared by the party applying for the assignment of class to a newbuilding. The date of 'contract for construction' of a series of sister ships, including specified optional ships for which the option is ultimately exercised, is the date on which the contract to build the series is signed between the prospective shipowner and the ship builder. In this section a 'series of sister ships' is a series of ships built to the same approved plans for classification purposes, under a single contract for construction. The optional ships will be considered part of the same series of sister ships if the option is exercised not later than 1 year after the contract to build the series was signed. If a contract for construction is later amended to include additional ships or additional options, the date of 'contract for construction' for such ships is the date on which the amendment to the contract is signed between the prospective shipowner and the ship builder. The amendment to the contract is to be considered as a 'new contract'. If a contract for construction is amended to change the ship type, the date of 'contract for construction' of this modified vessel, or vessels, is the date on which the revised contract or new contract is signed between the Owner, or Owners, and the shipbuilder. Where it is desired to use existing approved ship or machinery plans for a new contract, written application is to be made to LR. Sister ships may have minor design alterations provided that such alterations do not affect matters related to classification, or if the alterations are subject to classification requirements, these alterations are to comply with the classification requirements in effect on the date on which the alterations are contracted between the prospective owner and the ship builder or, in the absence of the alteration contract, comply with the classification requirements in effect on the date on which the alterations are submitted to LR for approval.
- (c) All reports of survey are to be made by surveyors authorised by members of the LR Group to survey and report (hereinafter referred to as 'the Surveyors') according to the form prescribed, and submitted for the consideration of the Classification Committee.
- (d) Information contained in the reports of classification and statutory surveys will be made available to the relevant owner, National Administration, Port State Administration, P&I Club, hull underwriter and, if authorised in writing by that owner, to any other person or organisation.
- (e) Notwithstanding the general duty of confidentiality owed by LR to its client in accordance with the LR Rules, LR clients hereby accept that, LR will participate in the IACS Early Warning System which requires each IACS member to provide its fellow IACS members and Associates with relevant technical information on serious hull structural and engineering systems failures, as defined in the IACS Early Warning System (but not including any drawings relating to the ship which may be the specific property of another party), to enable such useful information to be shared and utilised to facilitate the proper working of the IACS Early Warning System. LR will provide its client with written details of such information upon sending the same to IACS Members and Associates.
- (f) Information relating to the status of classification and statutory surveys and suspensions/withdrawals of class together with any associated conditions of class will be made available as required by applicable legislation or court order.
- (g) A Classification Executive consisting of senior members of LR's Classification Department staff shall carry out whatever duties that may be within the function of the Classification Committee that the Classification Committee assigns to it.

■ *Section 6*
Ethics

6.1 No LR Group employee is permitted under any circumstances, to accept, directly or indirectly, from any person, firm or company, with whom the work of the employee brings the employee into contact, any present, bonus, entertainment or honorarium of any sort whatsoever which is of more than nominal value or which might be construed to exceed customary courtesy extended in accordance with accepted ethical business standards.

■ *Section 7*
Non-Payment of Fees

7.1 LR has the power to withhold or, if already granted, to suspend or withdraw any ship from class (or to withhold any certificate or report in any other case), in the event of non-payment of any fee to any member of the LR Group.

■ *Section 8*
Limits of Liability

8.1 When providing services LR does not assess compliance with any standard other than the applicable LR Rules, international conventions and other standards agreed in writing.

8.2 In providing services, information or advice, LR does not warrant the accuracy of any information or advice supplied. Except as set out herein, LR will not be liable for any loss, damage or expense sustained by any person and caused by any act, omission, error, negligence or strict liability of LR or caused by any inaccuracy in any information or advice given in any way by or on behalf of LR even if held to amount to a breach of warranty. Nevertheless, if the Client uses LR services or relies on any information or advice given by or on behalf of LR and as a result suffers loss, damage or expense that is proved to have been caused by any negligent act, omission or error of LR or any negligent inaccuracy in information or advice given by or on behalf of LR then LR will pay compensation to the client for its proved loss up to but not exceeding the amount of the fee (if any) charged for that particular service, information or advice.

8.3 LR will print on all certificates and reports the following notice: Lloyd's Register Group Limited, its affiliates and subsidiaries and their respective officers, employees or agents are, individually and collectively, referred to in this clause as 'Lloyd's Register'. Lloyd's Register assumes no responsibility and shall not be liable to any person for any loss, damage or expense caused by reliance on the information or advice in this document or howsoever provided, unless that person has signed a contract with the relevant Lloyd's Register entity for the provision of this information or advice and in that case any responsibility or liability is exclusively on the terms and conditions set out in that contract.

8.4 Except in the circumstances of section 8.2 above, LR will not be liable for any loss of profit, loss of contract, loss of use or any indirect or consequential loss, damage or expense sustained by any person caused by any act, omission or error or caused by any inaccuracy in any information or advice given in any way by or on behalf of LR even if held to amount to a breach of warranty.

8.5 Any dispute about LR services is subject to the exclusive jurisdiction of the English courts and will be governed by English law.

Section

- 1 **Conditions for classification**
- 2 **Character of classification and class notations**
- 3 **Surveys - General**
- 4 **IACS and EMSA Audits and Assessments**
- 5 **Type Approval/Type Testing/Quality Control System**
- 6 **Classification of machinery with [⊗] LMC or MCH notation**

■ *Section 1* **Conditions for classification**

1.1 General

1.1.1 Ships referred to in this Chapter are defined in *Pt 3 Ship Structures (General)*, *Pt 4 Ship Structures (Ship Types)* and *Pt 7 Other Ship Types and Systems* of these Rules. Machinery referred to in this Chapter is defined in *Pt 5 Main and Auxiliary Machinery* and *Pt 6 Control, Electrical, Refrigeration and Fire* of these Rules. Systems referred to in this Chapter are defined in *Pt 7 Other Ship Types and Systems* of these Rules. Materials are referred to in the *Rules for the Manufacture, Testing and Certification of Materials, July 2015* (hereinafter referred to as the Rules for Materials).

1.1.2 Ships built in accordance with Lloyd's Register Group Limited's Rules and Regulations, or in accordance with requirements equivalent thereto, will be assigned a class in the *Register Book* and will continue to be classed as long as they are found, upon examination at the prescribed surveys, to be maintained in accordance with the requirements of the Rules. Classification will be conditional upon compliance with LR's requirements for both hull and machinery and with the Certification Requirements of *Pt 1, Ch 2, 1.1 General*.

1.1.3 The Classification Committee, in addition to requiring compliance with LR's Rules, may require to be satisfied that ships are suitable for the geographical or other limits or conditions of the service contemplated.

1.1.4 Loading conditions and any other preparations required to permit a ship with a class notation specifying some service limitation to undertake a sea-going voyage, either from port of building to service area or from one service area to another, are to be in accordance with arrangements agreed by LR prior to the voyage.

1.1.5 Any damage, defect, breakdown, grounding, serious deficiency, detention or, arrest or refusal of access, which could invalidate the conditions for which a class has been assigned, is to be reported to LR without delay.

1.1.6 The Rules are framed on the understanding that ships will be properly loaded and handled. They do not, unless stated or implied in the class notation, provide for special distributions or concentrations of loading. The Classification Committee may require additional strengthening to be fitted in any ship which, in their opinion, would otherwise be subjected to severe stresses due to particular features in the design, or where it is desired to make provision for exceptional loaded or ballast conditions. In such cases, particulars are to be submitted for consideration.

1.1.7 When longitudinal strength calculations have been required, loading guidance information is supplied to the Master by means of a Loading Manual and in addition, when required, by means of a loading instrument.

1.1.8 The Rules are framed on the understanding that ships will not be operated in environmental conditions more severe than those agreed for the design basis and approval, without the prior agreement of LR.

1.1.9 For ships, the arrangements and equipment of which are required to comply with the requirements of the:

- Load Lines Convention;
- *International Convention for the Safety of Life at Sea, 1974* and its Protocol of 1978;
- *International Convention for the Prevention of Pollution from Ships, 1973*, as modified by the Protocol of 1978 relating thereto;
- *International Code for the Construction and Equipment of Ships Carrying Dangerous Chemicals in Bulk (IBC Code)*;

- *International Code for the Construction and Equipment of Ships Carrying Liquefied Gases in Bulk (IGC Code);*

and applicable Amendments thereto, the Classification Committee requires the applicable Convention Certificates to be issued by a National Administration, or by LR, or by an IACS Member when so authorised. Safety Management Certificates in accordance with the provisions of the *International Safety Management Code (ISM Code)* may be issued by an organisation complying with IMO Resolution A.739(18) and authorised by the National Authority with which the ship is registered. Cargo Ship Radio Certificates may be issued by an organisation authorised by the National Administration with which the ship is registered. In the case of dual-classed ships, Convention Certificates may be issued by the other Society with which the ship is classed provided this is recognised in a formal Dual Class Agreement with LR and provided the other Society is also authorised by the National Administration. In the event of a National Administration withdrawing any ship's Convention Certificate (referred to in this section) then the Classification Committee may suspend the ship's class. If a ship is removed from the National Administration's Registry for the non-compliance with the Conventions or Classification Requirements referred to herein then the Classification Committee will suspend the ship's class. In the event of ISM Code certification being withdrawn from a ship or Operator then the Classification Committee will suspend the ship's class.

1.1.10 Where an onboard computer system having longitudinal strength computation capability, which is required by the Rules, is provided on a new ship, or newly installed on an existing ship, then the system is to be certified in respect of longitudinal strength in accordance with LR's document entitled *Approval of Longitudinal Strength and Stability Calculation Programs*, see also *Pt 3, Ch 4, 8 Loading guidance information*

1.1.11 Where an onboard computer system having stability computation capability is provided on a new ship, then the system is to be certified in respect of stability aspects in accordance with LR's document entitled, *Approval of Longitudinal Strength and Stability Calculation Programs*. When provided, an onboard computer system having stability computation capability is to carry out the calculations and checks necessary to assess compliance with all the stability requirements applicable to the ship on which it is installed.

1.1.12 Where a ship has been detained by Port State Control the Owner is to advise LR immediately in order to arrange the attendance of a Surveyor.

1.2 Advisory services

1.2.1 The Rules do not cover certain technical characteristics, such as stability, trim, hull vibration, etc., but advice may be given on such matters without any assumption of responsibility for such advice.

■ *Section 2*

Character of classification and class notations

2.1 Definitions

Note For the purpose of class notations, the definitions given in *Pt 1, Ch 2, 2.1 Definitions 2.1.2 to Pt 1, Ch 2, 2.1 Definitions 2.1.12* will apply.

2.1.2 **Clear water.** Water having sufficient depth to permit the normal development of wind generated waves.

2.1.3 **Fetch.** The extent of clear water across which a wind has blown before reaching the ship.

2.1.4 **Sheltered water.** Water where the fetch is six nautical miles or less.

2.1.5 **Reasonable weather.** Wind strengths of force six or less in the Beaufort scale, associated with sea states sufficiently moderate to ensure that green water is taken on board the ship's deck at infrequent intervals only or not at all.

2.1.6 **Type notation.** A notation indicating that the ship has been arranged and constructed in compliance with particular Rules intended to apply to that type of ship. Type notations that may be assigned are listed in *Table 2.2.1 Type notations*.

Classification Regulations

Part 1, Chapter 2

Section 2

Table 2.2.1 Type notations

Dry cargo	Tanker	Passenger
Anchor handler	Chemical tanker	Passenger ferry
AHTS (Anchor Handler Tug Ship)	Double hull oil tanker	Passenger/vehicle ferry
Barge	Liquefied gas carrier	Passenger ship
Bulk carrier	Liquefied gas tanker	Passenger yacht
Container ship	Oil barge	Roll on-Roll off passenger ship
Diving support ship	Oil or bulk carrier	Sailing passenger ship
Dredger	Oil recovery ship	
Escort tug	Oil tanker	
Fire fighting	Ore or oil carrier	
Fishing vessel		
Hopper barge		
Hopper dredger		
Icebreaker		
Icebreaker(+)		
Launch		
Livestock carrier		
Offshore supply		
Offshore tug		
Offshore well stimulation		
Ore carrier		
Pipe laying		
Pontoon		
Reclamation ship		
Refrigerated cargo ship		
Research		
Roll on-Roll off cargo ship		
Shipborne barge		
Standby ship		
Stern trawler		
Split hopper barge		
Split hopper dredger		
Trawler		
Tug		
Vehicle carrier		

2.1.7 **Cargo notation.** A notation indicating that the ship has been designed, modified or arranged to carry one or more particular cargoes, e.g. sulphuric acid. Ships with one or more particular cargo notations are not thereby prevented from carrying other cargoes for which they are suitable.

2.1.8 **Special duties notation.** A notation indicating that the ship has been designed, modified or arranged for special duties other than those implied by the type and cargo notations, e.g. research. Ships with special duties notations are not thereby prevented from performing any other duties for which they may be suitable.

2.1.9 **ShipRight notation.** Where one or more of LR's ShipRight notation procedures have been satisfactorily applied, then a notation showing the associated characters of the procedure(s) within brackets will, at the Owner's request, be entered in column 4 of the *Register Book*, preceded by the word **ShipRight**, see *Pt 1, Ch 2, 2.3 Class notations (hull) 2.3.17*. Other ShipRight procedures that have been satisfactorily applied will similarly be shown as descriptive notes and will appear in column 6 of the *Register Book*, see *Pt 1, Ch 2, 2.8 Descriptive notes 2.8.2*.

2.1.10 **Special features notation.** A notation indicating that the ship incorporates special features which significantly affect the design, see *Table 2.2.2 Special features notations*.

Table 2.2.2 Special features notations

Special features notation	Description	See also
BC	Assigned to bulk carriers of length 150 m or above	<i>Pt 4, Ch 7, 1.4 Class notation for CSR bulk carriers 1.4.2</i>
Bottom Strengthened for (Operating Aground) (Loading and Unloading Aground)	Assigned where the bottom structure has been additionally strengthened for loading and unloading aground	<i>Pt 3, Ch 9, 7 Bottom strengthening for loading and unloading aground and Pt 4, Ch 12, 1.3 Class notations 1.3.4</i>
BLS	Bow Loading System. Assigned to tankers equipped with bow loading arrangements to facilitate the transfer of cargo oil from offshore loading terminals	<i>Pt 7, Ch 6, 1.2 Class notations 1.2.1</i>
BoxMax	Where a container ship has an approved onboard container lashing program which is installed and maintained in accordance with the requirements of the Rules, the special features notation BoxMax may be assigned on application from Owners. In conjunction with the notation BoxMax , the following supplementary characters may be assigned and are to be shown consecutively in brackets; V may be assigned where, in addition to the requirements for BoxMax , the onboard lashing program is capable of performing calculations specific to defined sea areas, and the weather-dependent factors for these areas have been supplied by LR; W may be assigned where, in addition to the requirements for BoxMax(V) , the onboard lashing program is capable of performing calculations specific to defined sea areas and seasons, and the weather-dependent factors for these areas and seasons have been supplied by LR	<i>Pt 3, Ch 4 Longitudinal Strength and Pt 3, Ch 14 Cargo Securing Arrangements</i>
Cargo Loading on (Tank Top/ Tween/ Deck (s) Plating/ Hatch cover(s)) limited to tonnes/m²	Assigned where cargo loading on tank tops, decks and/or hatch covers are limited to a specified maximum value which is less than the normal Rule loading	—
Carriage of Oils with a F.P. not exceeding 60°C	Assigned to non-oil tankers where the ship is suitably constructed and arranged for the carriage of oils with a flash point not exceeding 60°C (closed cup test)	<i>Pt 4, Ch 9 Double Hull Oil Tankers Pt 4, Ch 10 Single Hull Oil Tankers</i>

Classification Regulations

Part 1, Chapter 2

Section 2

Carriage of Oils with a F.P. exceeding 60°C	Assigned where only the carriage of oils having a flash point exceeding 60°C (closed cup test) is contemplated	<i>Pt 4, Ch 9, 1.1 General 1.1.5</i>
(Specified Cargo(es)) only	Assigned where arrangements have been approved for the carriage of a specific product(s)	<i>Pt 4, Ch 9, 1.1 General 1.1.7</i>
CC	Assigned where structures are fitted with an approved corrosion control system	<i>Pt 1, Ch 3 Periodical Survey Regulations</i>
CCSA	Certified Container Securing Arrangements. Assigned where freight container securing arrangements are fitted, and the design and construction of the system is in accordance with LR Rules and loose fittings are supplied	<i>Pt 3, Ch 14 Cargo Securing Arrangements</i>
CG	Cargo Gear. Assigned where cargo gear is included in class at the Owner's request	<i>Pt 3, Ch 9, 6 Lifting appliances and support arrangements</i>
CL	Cargo Lift(s). Assigned where cargo lift(s) are included in class at the Owner's request	<i>Pt 3, Ch 9, 6 Lifting appliances and support arrangements</i>
CR	Cargo Ramp(s). Assigned where cargo ramp(s) are included in class at the Owner's request	<i>Pt 3, Ch 9, 6 Lifting appliances and support arrangements</i>
CRC -/- -kW -%/-%	<p>Carriage of refrigerated containers. The CRC notation may be applied to any ship which has the ability to carry refrigerated containers operating at their design condition with a 24-hour average external ambient air temperature of 35°C</p> <p>The following descriptive notations may be appended, giving details of electrical power and type of cargo:</p> <p>-/- No. of hold-stowed refrigerated containers/No. of deck-stowed refrigerated containers e.g. 230/140</p> <p>-kW Power generating capacity dedicated to supplying the container plug-in points, e.g. 2,800 kW</p> <p>-%/-% Stowage ratio of deep frozen and chilled cargoes, e.g. 60%/40%</p>	<i>Pt 7, Ch 10, 1.1 General</i>
Container Cargoes in ((all) Hold (No(s)))(and on Upper Deck)((and on (all) Hatch Cover(s) (No(s))...)	Assigned where general cargo ships carry container cargoes.	<i>Pt 3, Ch 4 Longitudinal Strength</i>
Deck No(s) ... Strengthened for Carriage of Roll on-Roll off Cargoes	Assigned where it is proposed either to stow wheeled vehicles on the deck or to use wheeled vehicles for cargo handling and the deck and supporting structure has been specially considered	<i>Pt 3, Ch 9, 3 Decks loaded by wheeled vehicles</i>
DSPM4	Dual Single Point Mooring. Assigned to a ship provided with a dual mooring line arrangement at a single-point mooring	<i>Pt 3, Ch 13, 8 Windlass design and testing</i>
ECL(1, 2, 3)	Assigned to vessels where work spaces, movement about the ship, fall protection and working arrangements on deck have been specially considered for performing container securing, inspection and other related tasks	<i>Provisional Rules for Ergonomic Container Lashing, December 2014</i>

Classification Regulations

Part 1, Chapter 2

Section 2

ELD	Assigned when ergonomic lighting design has been applied	<i>Pt 6, Ch 2, 23 Ergonomic Lighting Design – ELD optional notation and Pt 16, Ch 2, 22 Ergonomic Lighting Design – ELD optional notation</i>
Fire-Fighting Ship 1, 2, 3 (with water spray)	Designed where fire protection and fire-fighting equipment is provided. Type 1, 2 or 3 signifies the capacity of the fire-fighting equipment. The total discharge capacity of the monitors in m ³ /h is shown in brackets. 'With water spray' signifies that a ship is provided with a water spray system which will provide an effective cooling spray of water	<i>Pt 7, Ch 3 Fire-fighting Ships</i>
Hatch Covers omitted in Hold (No(s)) ...	Assigned where the omission of hatch covers have been specially considered based upon the model tests or alternative means to determine the quantity of water likely to ingress the cargo holds and the means by which it is effectively and safely discharged	<i>Pt 4, Ch 8, 11.4 Omission of hatch covers</i>
Heavy Deck Loads	Assigned where decks are strengthened for loading in excess of Rule basic minimum, e.g. 'Upper deck aft of Fr. 50 strengthened for load of 10 tonnes/m ² '	<i>Pt 3, Ch 6 Aft End Structure</i>
Helideck	Assigned where a designated helicopter landing platform or other deck area with fire-fighting appliances and other equipment necessary for the safe operation of helicopters are provided.	<i>Pt 3, Ch 9, 5 Helicopter landing areas</i>
Occasional Helicopter Landing Area	Assigned where an area on a ship designated for occasional or emergency landing of helicopters is provided.	<i>Pt 3, Ch 9, 5 Helicopter landing areas</i>
Hold (No(s)) ... may be empty at draughts not (less than) (exceeding) ...m	Assigned where particular loading arrangements have been specially considered	<i>Pt 4, Ch 7 Bulk Carriers</i>
Ice Class	Assigned where a ship is strengthened to navigate in specific ice conditions. Supplementary Ice Class notations are given in <i>Table 2.2.3 Notations for ice and cold operations</i>	<i>Pt 8, Ch 1 Application and Pt 8, Ch 2 Ice Operations - Ice Class</i>
Icebreaker	Assigned designed for icebreaking duties	<i>Pt 8, Ch 1 Application and Pt 8, Ch 2 Ice Operations - Ice Class</i>
LA	Mandatory Lifting Appliance(s). Assigned where the lifting appliance is considered to be an essential feature, e.g. cranes on crane barges, lifting arrangements for diving on diving support ships, and is mandatory	<i>Pt 3, Ch 9, 6 Lifting appliances and support arrangements</i>
LFPL	Low Flashpoint liquids. Assigned to offshore supply ships intended for the carriage of liquids with flashpoint below 60°C (closed cup test) in bulk	<i>Pt 4, Ch 4 Offshore Support Vessels</i>
For Liquefaction and Storage of (Methane, etc.) in Independent Gas Tanks (Type B, etc.), Maximum Vapour Pressure () bar, Minimum Temperature Minus () °C	Assigned where ships of Category 1B or 2 which have process plants installed solely for the purposes of the physical liquefaction of impure feedstock gases at low temperature and the storage of the purified liquefied gases (where the chemical treatment of the impurities is an incidental process)	<i>Pt 7, Ch 2, 2.2 Additional notations</i>

Classification Regulations

Part 1, Chapter 2 Section 2

Marpol 20.1.3	Assigned to double hull oil tankers not meeting the Rule minimum double side width requirements but which comply with MARPOL Annex 1, Regulation 20.1.3	<i>Pt 4, Ch 9, 1.4 Class notation and applicable Rules for non-CSR Double Hull Oil Tankers 1.4.3</i>
Marpol 21.1.2	Assigned to double hull oil tankers of less than 5000 tonnes deadweight which have a complete double hull in accordance with MARPOL Annex I, Regulation 21.1.2	<i>Pt 4, Ch 9, 1.4 Class notation and applicable Rules for non-CSR Double Hull Oil Tankers 1.4.4</i>
Movable Decks	Assigned where all movable decks comply with LR requirements. Movable decks other than those specifically indicated in LR Rule requirements are not a classification item	<i>Pt 3, Ch 9, 4 Movable decks</i>
Oil Recovery	Assigned when a ship is equipped for oil recovery operations	<i>Pt 7, Ch 5, 2 Oil recovery</i>
Petrol in Hold (No(s))...	Assigned to ships that can carry motor vehicles with fuel in their tanks for self-propulsion, in specified locations. It does not apply to ships that are designed primarily for the carriage of motor vehicles Specific requirements will be advised upon request	—
PL	Passenger Lift(s). Assigned where the passenger lift(s) are included in class at the Owner's request	<i>Pt 3, Ch 9, 6 Lifting appliances and support arrangements</i>
PM (T1) [or (T2) or (T3)]	For ships fitted with a positional mooring system (PM). The supplementary notation (T1) [or (T2) or (T3)] may be applied if the system is thruster-assisted. The encircled numeral defines the thruster allowance	<i>Pt 7, Ch 8, 1.2 Classification notations 1.2.1</i>
PMC (T1) [or (T2) or (T3)]	For ships fitted with a positional mooring system for mooring in close proximity to other ships or installations (PMC). The supplementary notation (T1) [or (T2) or (T3)] may be applied if the system is thruster-assisted. The encircled numeral defines the thruster allowance	<i>Pt 7, Ch 8, 1.2 Classification notations 1.2.1</i>
RD	Relative Density. Assigned where a ship has tanks appraised for a maximum permissible relative density greater than 1,025	<i>Pt 4, Ch 1 General Cargo Ships Pt 4, Ch 4 Offshore Support Vessels</i>
Self-Discharging (Unloading)	Assigned where a ship fitted with self-unloading equipment whose structural aspect has been specially approved	<i>Pt 4, Ch 12, 1 General</i>
SLS	Stern Loading System. Assigned to tankers equipped with stern loading arrangements to facilitate the transfer of cargo oil from offshore loading terminals	<i>Pt 7, Ch 6, 1 General</i>
Specialised for the Carriage of ...	Assigned to a vessel which has been designed for the carriage of specified cargo other than that applied by the type notation	<i>Pt 4, Ch 4, 1 General</i>
SPM4	Single Point Mooring. Assigned to a ship provided with a single mooring line arrangement at a single point mooring	<i>Pt 3, Ch 13, 8 Windlass design and testing</i>
Strengthened for Heavy Cargoes ((any) Hold (No(s)) may be empty)	Assigned to a bulk carrier of less than 150 m in length or a ship designed for the carriage of heavy cargoes. If only certain holds are strengthened for heavy cargoes, they will be specified	<i>Pt 4, Ch 1 General Cargo Ships and Pt 4, Ch 7, 1 General</i>
HNLS	Hazardous and noxious liquids system. Assigned to ships complying with the requirements for the transport and handling of limited amounts of hazardous and noxious liquid substances in bulk	<i>Pt 4, Ch 4, 8.1 General 8.1.6</i>
Hold No(s) ... Strengthened for Regular Discharge by Heavy Grabs	Assigned to bulk carriers where cargoes are regularly discharged by heavy grabs and the thickness of the plating of the hold inner bottom, hopper and transverse bulkhead bottom stool is increased	<i>Pt 3, Ch 9,7</i>

Submersible to a depth of ...m below Upper Deck in Harbour only	Assigned to a ship that is designed so that it can be submersed to a specified depth in harbour only	—
Timber Deck Cargoes	Assigned where a cargo of timber is carried on an uncovered part of the freeboard or superstructure deck (does not include wood pulp or similar cargo) and the requirements of the 1966 Load Line Convention concerning timber deck cargoes or other National Regulations are complied with	<i>Pt 3, Ch 9, 2 Timber deck cargoes</i>
TLS	Submerged Turret Loading System. Assigned to tankers equipped with submerged turret loading systems to facilitate the transfer of cargo oil from offshore loading to terminals	<i>Pt 7, Ch 6, 1 General</i>
Winterisation	Assigned to a ship that is intended to navigate in cold climates and may be exposed to low temperatures that may cause equipment to freeze due to ice accretion from atmospheric icing or sea spray or due to freezing of liquid within a system. Protection measures are provided and operational procedures are specified to ensure that equipment is suitably protected to enable operation in low temperatures. Supplementary Winterisation notations are given in <i>Table 2.2.3 Notations for ice and cold operations</i>	<i>Pt 8, Ch 1 Application and Pt 8, Ch 2 Ice Operations - Ice Class</i>
WDL(+)	Weather Deck Load. Assigned where the weather deck load scantlings have been approved for a loading greater than a design head of 3,5 m	<i>Pt 4, Ch 1 General Cargo Ships and Pt 4, Ch 4 Offshore Support Vessels</i>

Table 2.2.3 Notations for ice and cold operations

Notation	Description	Conditions	Application	See also
Ice Class 1E	For offshore supply vessels	Light and very light ice conditions	Hull, Machinery	<i>Pt 8, Ch 2, 4 Hull requirements for light ice conditions – Ice Classes 1D and 1E and Pt 8, Ch 2, 5 Machinery requirements for light ice conditions – Ice Classes 1D and 1E</i>
Ice Class 1D	Hull strengthening in forward region only			
Ice Class 1C FS	Finnish Swedish Ice Class Rules	Ice Class 1C; ships with such structure, engine output and other properties that they are capable of navigating in light ice conditions, with the assistance of icebreakers when necessary;	Hull, Machinery	<i>Pt 8, Ch 2, 6 Hull requirements for first-year ice conditions – Ice Classes 1AS FS, 1A FS, 1B FS, 1C FS and 1D and Pt 8, Ch 2, 7 Machinery requirements for first-year ice conditions – Ice Classes 1AS FS, 1A FS, 1B FS and 1C FS</i>
Ice Class 1B FS		Ice Class 1B; ships with such structure, engine output and other properties that they are capable of navigating in moderate ice conditions, with the assistance of icebreakers when necessary		
Ice Class 1A FS		Ice Class 1A; ships with such structure, engine output and other properties that they are capable of navigating in difficult ice conditions, with the assistance of icebreakers when necessary		

Classification Regulations

Part 1, Chapter 2 Section 2

Ice Class 1AS FS		Ice Class 1A Super; ships with such structure, engine output and other properties that they are normally capable of navigating in difficult ice conditions without the assistance of icebreakers		
Ice Class 1C FS(+)	Finnish Swedish Ice Class Rules with enhanced engine power for icebreaking capability	Ice Class 1C; ships with such structure, engine output and other properties that they are capable of navigating in light ice conditions, with the assistance of icebreakers when necessary	Hull, Machinery	<i>Pt 8, Ch 2, 8 Hull requirements for first-year ice conditions – Ice classes 1AS FS(+), 1A FS(+), 1B FS(+) and 1C FS(+) and Pt 8, Ch 2, 9 Machinery requirements for first-year ice conditions - Ice classes 1AS FS(+), 1A FS(+), 1B FS(+) and 1C FS(+)</i>
Ice Class 1B FS(+)		Ice Class 1B; ships with such structure, engine output and other properties that they are capable of navigating in moderate ice conditions, with the assistance of icebreakers when necessary		
Ice Class 1A FS(+)		Ice Class 1A; ships with such structure, engine output and other properties that they are capable of navigating in difficult ice conditions, with the assistance of icebreakers when necessary		
Ice Class 1AS FS(+)		Ice Class 1A Super; ships with such structure, engine output and other properties that they are normally capable of navigating in difficult ice conditions without the assistance of icebreakers		
Ice Class PC7		IACS Polar Ship Rules		
Ice Class PC6	Summer/autumn operation in medium first-year ice which may include old ice inclusions			
Ice Class PC5	Year-round operation in medium first-year ice which may include old ice inclusions			
Ice Class PC4	Year-round operation in thick first-year ice which may include old ice inclusions			
Ice Class PC3	Year-round operation in second-year ice which may include multi-year ice inclusions			

Ice Class PC2		Year-round operation in moderate multi-year ice conditions		
Ice Class PC1		Year-round operation in all Polar waters		
Winterisation H(†)	Hull construction materials	Low temperature operations	Hull, materials	<i>Ch 1, 2 Materials for hull construction at low temperatures – Winterisation H of the Provisional Rules for the Winterisation of Ships</i>
Winterisation C(†)	Short duration			
Winterisation B(†)	Seasonal duration		Equipment and systems	<i>Ch 1, 3 Materials for equipment and components at low temperatures – Winterisation M of the Provisional Rules for the Winterisation of Ships</i>
Winterisation A(†)	Prolonged duration			

2.1.11 **Service restriction notation.** A notation indicating that a ship has been classed on the understanding that it will be operated only in suitable areas or conditions which have been agreed by the Classification Committee, e.g. protected waters service.

2.1.12 **Linked** means connected, while in operation, to an attendant ship (which may be on shore, submerged or afloat) by a restraining line, suspension cable or umbilical cord.

2.1.13 **Laid-up notation.** A ship not under repair or not actively employed may be assigned the laid-up notation in order to maintain the ship in class subject to agreement by the Classification Committee. A general examination of the hull and machinery is to be carried out in lieu of the Annual Survey. An Underwater Examination (UWE) is to be carried out in lieu of the Special Survey. See Pt 1, Ch 3, 1.1 Frequency of surveys 1.1.2, Pt 1, Ch 3, 2.1 General 2.1.5, Pt 1, Ch 3, 5.1 General 5.1.6 and Pt 1, Ch 3, 11.1 Annual, Intermediate and Docking Surveys 11.1.2.

2.2 Character symbols

2.2.1 All ships, when classed, will be assigned one or more character symbols as applicable. For the majority of ships, the character assigned will be **100A1**, **✱ 100A1** or **✳ 100A1**.

2.2.2 A full list of character symbols for which ships may be eligible is as follows:

✱ = This distinguishing mark will be assigned, at the time of classing, to new ships constructed under LR's Special Survey in compliance with the Rules, and to the satisfaction of the Classification Committee.

✳ = This distinguishing mark, will be assigned to ships built under supervision of another IACS member society and later assigned class with LR. For such ships the class notations will be reviewed separately and equivalent notations will be assigned.

100 = This character figure will be assigned to all ships considered suitable for sea-going service.

A = This character letter will be assigned to all ships which have been built or accepted into class in accordance with LR's Rules and Regulations, and which are maintained in good and efficient condition.

1 = This character figure will be assigned to:

- = (a) Ships having on board, in good and efficient condition, anchoring and/or mooring equipment in accordance with the Rules.
- = (b) Ships classed for a special service, having on board, in good and efficient condition, anchoring and/or mooring equipment approved by the Classification Committee as suitable and sufficient for the particular service.

N = This character letter will be assigned to ships on which the Classification Committee has agreed that anchoring and mooring equipment need not be fitted in view of their particular service.

T = This character letter will be assigned to ships which are intended to perform their primary designed service function only while they are anchored, moored, towed or linked, and which have, in good and efficient condition, adequately attached anchoring, mooring, towing or linking equipment which has been approved by the Classification Committee as suitable and sufficient for the intended service.

2.2.3 For classification purposes, the character figure **1**, or either of the character letters **N** or **T**, is to be assigned.

2.2.4 In cases where the anchoring and/or mooring equipment is found to be seriously deficient in quality or quantity, the class of the ship will be liable to be withheld.

2.3 Class notations (hull)

2.3.1 When considered necessary by the Classification Committee, or when requested by an Owner and agreed by the Classification Committee, a class notation will be appended to the character of classification assigned to the ship. This class notation will consist of one of, or a combination of: a type notation, a cargo notation, a special duties notation, a special features notation and/or a service restriction notation, e.g. ` * **100A1** Oil Tanker F.P. exceeding 60°C in No. 4 tanks ESP Baltic Service Ice Class 1B'.

2.3.2 Details of the ship types and particular cargoes for which special Rules apply are given in those Chapters of *Pt 3 Ship Structures (General)*, *Pt 4 Ship Structures (Ship Types)* and *Pt 7 Other Ship Types and Systems* which apply to such ships and cargoes.

2.3.3 Details of the more common special features and the conditions relevant to the assignment of special features notations, together with the form of such notations, are incorporated in *Pt 3 Ship Structures (General)*, *Pt 4 Ship Structures (Ship Types)* and *Pt 7 Other Ship Types and Systems* as applicable.

2.3.4 Service restriction notations will generally be assigned in one of the forms shown in *Pt 1, Ch 2, 2.3 Class notations (hull) 2.3.6 to Pt 1, Ch 2, 2.3 Class notations (hull) 2.3.10*, but this does not preclude Owners or Shipbuilders requesting special consideration for other forms in unusual cases.

2.3.5 Where a service notation is applicable, certain exemptions may be granted. Where these affect statutory requirements, such as Load Lines, the Owner or shipbuilder is to obtain the authorisation of the Flag State. Such exemptions are to be recorded on the Class certificate and any applicable statutory certificate.

2.3.6 **Protected waters service.** Service in sheltered water adjacent to sand banks, reefs, breakwaters or other coastal features, and in sheltered water between islands, e.g. 'Protected Waters Service at Storebaelt Bridge'.

2.3.7 **Extended protected waters service.** Service in protected waters and also for short distances (generally less than 15 nautical miles) beyond protected waters in 'reasonable weather', e.g. 'Extended Protected Waters Service from the Port of Lagos'.

2.3.8 **Specified coastal service.** Service along a coast, the geographical limits of which will be indicated in the *Register Book*, and for a distance out to sea generally not exceeding 21 nautical miles, unless some other distance is specified for 'coastal service' by the Administration with which the ship is registered, or by the Administration of the coast off which it is operating, as applicable, e.g. 'Indonesian coastal service'.

2.3.9 **Specified route service.** Service between two or more ports or other geographical features which will be indicated in the *Register Book*,

e.g.

- 'London to Rotterdam service'
- 'London, Rotterdam and Hamburg service'.

2.3.10 **Specified operating area service.** Service within one or more geographical area(s) which will be indicated in the *Register Book*,

e.g.

- 'Pacific Tropical Zone service'
- 'Great Lakes and St. Lawrence to Pt. du Monts service'
- 'Red Sea, Eastern Mediterranean and Black Sea service'.

2.3.11 ***IWS.** This notation (In-water Survey) may be assigned to a ship where the applicable requirements of LR's Rules and Regulations are complied with, see *Pt 1, Ch 3, 4.3 In-water Surveys; Pt 3, Ch 1, 5.2 Plans and supporting calculations and Pt 3, Ch 1, 5.3 Plans to be supplied to the ship; Pt 3, Ch 2, 3.5 External hull protection; Pt 3, Ch 13, 2.9 Pintles and Pt 5, Ch 6, 3.12 Sternbushes*. The notation will be withdrawn for **ESP** ships upon reaching 15 years of age.

2.3.12 **ESP.** This notation (Enhanced Survey Programme) will be assigned to oil tankers, combination carriers, chemical tankers, bulk carriers and ore carriers, as defined in *Pt 1, Ch 3, 1.5 Definitions* which are subject to an enhanced survey programme as detailed in *Pt 1, Ch 3, 3 Intermediate Surveys - Hull and machinery requirements, Pt 1, Ch 3, 6 Special Survey - Bulk carriers - Hull requirements, Pt 1, Ch 3, 7 Special Survey - Oil tankers (including ore/oil ships and ore/bulk/oil ships) - Hull requirements and Pt 1, Ch 3, 8 Special Survey - Chemical Tankers - Hull requirements*.

2.3.13 **CSR.** This notation will be assigned to bulk carriers and double hull oil tankers compliant with the *IACS Common Structural Rules for Bulk Carriers and Oil Tankers (CSR)*, see *Pt 4, Ch 7, 1.2 Application 1.2.1 and Pt 4, Ch 9, 1.2 Application and ship arrangement 1.2.1*. Additional mandatory and non-mandatory class notations for CSR bulk carriers are given in *Pt 1, Ch 2, 2.3 Class notations (hull) 2.3.14*.

2.3.14 **Class notations for CSR bulk carriers.** In general, CSR bulk carriers less than 150 m in length are to comply with the requirements of *Pt 4, Ch 7, 1.4 Class notation for CSR bulk carriers* and the *IACS Common Structural Rules (CSR)* and will be eligible for one of the following mandatory class notations:

{any holds may be empty} This class notation is normally assigned to a ship designed to carry dry bulk cargoes of cargo density 1,0 tonne/m³ and above, with an approved arrangement of loaded holds such that any hold may be empty at the maximum draught.

{holds a, b, ... may be empty} This class notation is normally assigned to a ship designed to carry dry bulk cargoes of cargo density 1,0 tonne/m³ and above with specified holds empty at maximum draught.

In general, CSR bulk carriers equal to or greater than 150 m in length are to comply with the requirements of *Pt 4, Ch 7, 1.5 Class notation for non-CSR bulk carriers* and the *IACS Common Structural Rules (CSR)* and will be eligible for one of the following mandatory class notations:

BC-A, {holds a, b, ... may be empty} This class will be assigned for bulk carriers designed to carry dry bulk cargoes of cargo density 1,0 tonne/m³ and above with specified holds empty at maximum draught.

BC-B This class will be assigned for bulk carriers designed to carry dry bulk cargoes of cargo density 1,0 tonne/m³ and above with all cargo holds loaded.

BC-C This class will be assigned for bulk carriers designed to carry dry bulk cargoes of cargo density less than 1,0 tonne/m³ with all cargo holds loaded.

The following additional notations and annotations are to be provided giving further detailed description of limitations to be observed during operation as a consequence of the design loading condition applied during the design:

(maximum cargo density (in tonnes/m³)) For notations **BC-A** and **BC-B** if the maximum cargo density is less than 3,0 tonnes/m³

(no MP) For all notations when the vessel has not been designed for loading and unloading in multiple ports in accordance with the conditions specified in *IACS Common Structural Rules (CSR)*, Pt 1, Ch 4, Sec 8,4.2.2;

GRAB [X] Where the net thickness of plating of inner bottom, hopper tank sloping plate, transverse lower stool, transverse bulkhead plating and inner hull up to a height of 3,0 m above the lowest point of the inner bottom, excluding bilge wells comply with IACS Common Structural Rules (CSR), Pt 2, Ch 1, 6 for BC-A and BC-B, see *IACS Common Structural Rules (CSR)*, Pt 1, Ch 1, Sec 1.3.2.1;

(allowed combination of specified empty holds) Annotation for notation **BC-A**.

2.3.15 **ESN**. This notation (Enhanced Survivability Notation) will be assigned to non-**CSR** bulk carriers which are designed to withstand the individual flooding of all cargo holds, see *Pt 4, Ch 7, 1.3 General class notations 1.3.2*.

2.3.16 **LI**. This notation will be assigned where an approved loading instrument has been installed as a classification requirement.

2.3.17 **ShipRight ()**. Where one or more of LR's ShipRight procedures for the following have been satisfactorily applied, then a notation showing the associated characters of the procedure(s) within brackets will, at the Owner's request, be entered in column 4 of the *Register Book*, preceded by the word **ShipRight**, e.g. **ShipRight(CM, SDA, FDA plus(25,NA))**. The requirements pertaining to these notations and the ShipRight procedures are given in *Pt 3, Ch 16 ShipRight Procedures for the Design, Construction and Lifetime Care of Ships*.

ACS() This ShipRight notation (Anti-Corrosion System) will be assigned when a specified area or areas of the ship have been protected against corrosion in accordance with the relevant ShipRight procedures. The **ACS()** notation with the extension of one or more of the following associated supplementary characters shown in brackets, detailing the specified protected area or areas, may be assigned;

- B** for protective coating system of water ballast tanks;
- D** for protective coating system of double-side skin spaces;
- C** for protective coating system of cargo oil tanks;
- C*** when corrosion resistant steel has been used in cargo oil tanks;
- V** for protective coating system of void spaces.

CM This ShipRight notation (Construction Monitoring), which complements the ShipRight **SDA, FDA, FDA plus()**, **FDA ICE, FDA SPR**, and **WDA** notations, will be assigned when the controls in construction tolerances detailed in the relevant ShipRight procedures have been applied and verified. The ShipRight notation **CM** is mandatory upon application of any of the following ShipRight notations: **SDA, FDA, FDA plus(), FDA ICE, FDA SPR** and **WDA**

FDA This ShipRight notation (Fatigue Design Assessment) will be assigned when an appraisal has been made of the fatigue performance of the hull structure in accordance with the relevant ShipRight procedures.

FDA plus() This ShipRight notation (Fatigue Design Assessment plus) will be assigned when an appraisal has been made for a higher level of fatigue performance than that made for the assignment of **FDA**. The appraisal may be made based upon a specific trading pattern, which is to be expressed in terms of either a Worldwide trading route, as defined in the relevant ShipRight procedures, or a North Atlantic trading route (that utilises the wave data from IACS Recommendation 34). The ShipRight notation **FDA plus()** is to be followed by the number of years that the vessel has been assessed for the specific trading pattern shown in brackets, for either the Worldwide or North Atlantic trading routes, denoted by **WW** and **NA** respectively, e.g. **FDA plus (25, NA)**.

FDA ICE This ShipRight notation (Fatigue Design Ice) will be assigned when an appraisal has been made for the fatigue performance of the hull structure when navigating through ice in accordance with the relevant ShipRight procedures.

FDA SPR This ShipRight notation (Springing Fatigue Assessment) will be assigned when an appraisal has been made of the fatigue performance of the hull structure taking into account the effects due to springing (the continuous vibrational response of the hull girder due to waves) in accordance with the relevant ShipRight procedures.

SDA This ShipRight notation (Structural Design Assessment) will be assigned when direct calculations in accordance with the relevant ShipRight procedures have been applied. The ShipRight notation **SDA** is mandatory upon application of any of the following ShipRight notations: **FDA, FDA plus(), FDA ICE, FDA SPR** and **WDA**.

WDA This ShipRight notation (Whipping Design Assessment) will be assigned when an appraisal has been made of the vibrational response of the hull structure due to wave impact loads (Whipping) in accordance with the relevant ShipRight procedures.

2.3.18 When the ShipRight notations **SDA, FDA, FDA plus(), FDA ICE, FDA SPR**, and **WDA** are assigned, the precise technical conditions of the appraisal will be made available to Owners.

2.3.19 **EU notations.** The following notations may be assigned to passenger ships that comply with the requirements of the European Council Directive 98/18/EC of 17 March 1998 on safety Rules and Standards for passenger ships, and subsequent revisions:

EU(A) This class notation will be assigned to a passenger ship engaged on domestic voyages other than voyages covered by Classes B, C and D.

EU(B) This class notation will be assigned to a passenger ship engaged on domestic voyages in the course of which it is at no time more than 20 miles from the line of coast, where shipwrecked persons can land, corresponding to the medium tide height.

EU(C) This class notation will be assigned to a passenger ship engaged on domestic voyages in sea areas where the probability of exceeding 2,5 m significant wave height is smaller than 10 per cent over a one-year period for all-year-round operation, or over a specific restricted period of the year for operation exclusively in such a period (e.g. summer period operation), in the course of which it is at no time more than 15 miles from a place of refuge, nor more than 5 miles from the line of coast, where shipwrecked persons can land, corresponding to the medium tide height.

EU(D) This class notation will be assigned to a passenger ship engaged on domestic voyages in sea areas where the probability of exceeding 1,5 m significant wave height is smaller than 10 per cent over a one-year period for all-year-round operation, or over a specific restricted period of the year for operation exclusively in such a period (e.g. summer period operation), in the course of which it is at no time more than 6 miles from a place of refuge, nor more than 3 miles from the line of coast, where shipwrecked persons can land, corresponding to the medium tide height.

2.3.20 The following notations may be assigned to ships that comply with standards for noise and vibration levels in different spaces at the time of delivery and during the ship's life if substantial changes to the machinery installation or interior arrangements are made.

PAC Passenger Accommodation Comfort. This notation indicates that the passenger accommodation meets the acceptance criteria.

CAC Crew Accommodation Comfort. This notation indicates that the crew accommodation and work areas meet the acceptance criteria.

PCAC Passenger and Crew Accommodation Comfort. This notation indicates that the passenger and crew spaces both meet the acceptance criteria.

Following the **PAC** or **CAC** notation, numerals 1, 2 or 3 will indicate the acceptance criteria to which the noise and vibration levels have been assessed. In the case of the **PCAC** notation, two numerals will be assigned. The first will indicate the acceptance criteria for passenger accommodation, whilst the second will indicate the crew comfort criteria. These notations are optional and are primarily intended to apply to passenger ships. Spaces that comply with the minimum Rule requirement for noise levels indicated in *Pt 7, Ch 12 Passenger and Crew Accommodation comfort*, will meet the requirements of section 4 of *IMO Resolution MSC.337(91) – Adoption of the Code on Noise Levels on Board Ships – (Adopted on 30 November 2012)* The Annex below is consolidated into *Noise Levels - Code on Noise Levels on Board Ships (Resolution MSC.337(91))*, when measured in accordance with the requirements of Chapters 2 and 3 of that Resolution

2.3.21 The notation **EPN** (escort performance numeral) may be assigned to escort tugs which carry out full-scale performance trials in accordance with the requirements of *Pt 4, Ch 3, 9.3 Performance numeral and trials*. **(F,B,V,C)** may be appended to the notations where:

F	Maximum steering force, in tonnes.
B	Maximum braking force, in tonnes.
V	Speed, in knots, at which F and B are determined.
C	Time, in seconds, required for the escort tug in manoeuvring from maintained oblique position of the tug giving it a maximum steering force on one side of the assisted vessel to a mirror position on the other side.

2.4 Class notations (machinery)

2.4.1 The following class notations are associated with the machinery construction and arrangement, and may be assigned as considered appropriate by the Classification Committee:

✳ **LMC** This notation will be assigned when the propelling and essential auxiliary machinery, see *Pt 1, Ch 2, 2.9 Application notes 2.9.1*, have been constructed, installed and tested under LR's Special Survey and in accordance with LR's Rules and Regulations for the Classification of Ships, see *Pt 1, Ch 2, 3.2 New construction surveys*.

[✳] **LMC** This notation will be assigned when:

- the propelling arrangements for propellers, propulsion shafting and multiple input/output gearboxes, steering systems, pressure vessels and electrical equipment for essential systems have been constructed, installed and tested under LR's Special Survey and are in accordance with LR's Rules and Regulations, see *Pt 1, Ch 2, 3.2 New construction surveys*.
- other items of machinery and gearing arrangements for propulsion and electrical power generation and other auxiliary machinery for essential services are in compliance with LR Rules and supplied with the Manufacturer's certificate, see *Pt 1, Ch 2, 2.9 Application notes 2.9.2*.
- the system arrangements of propelling and essential auxiliary machinery, see *Pt 1, Ch 2, 2.9 Application notes 2.9.1*, are appraised and found to be acceptable to LR.

✳ **LMC** This notation will be assigned to existing ships in service that will be accepted or transferred into LR class when:

- the propelling and essential auxiliary machinery, see *Pt 1, Ch 2, 2.9 Application notes 2.9.1*, have neither been constructed nor installed under LR's Special Survey.
- the existing machinery installation and arrangement have been tested and found to be acceptable to LR.

MCH This notation will be assigned when the:

- propelling and essential auxiliary machinery, see *Pt 1, Ch 2, 2.9 Application notes 2.9.1*, has been installed and tested under LR's survey and found to be acceptable to LR.
- propelling and essential auxiliary machinery has been supplied with a Manufacturer's certificate, see *Pt 1, Ch 2, 2.9 Application notes 2.9.3*.
- system arrangements of propelling and essential auxiliary machinery, see *Pt 1, Ch 2, 2.9 Application notes 2.9.1*, are appraised and found to be acceptable to LR.

IGS This notation will be assigned when a ship intended for the carriage of oil in bulk, or for the carriage of liquid chemicals in bulk, is fitted with an approved system for producing gas for inerting the cargo tanks.

2.4.2 The following class notations are associated with the machinery control and automation, and may be assigned as considered appropriate by the Classification Committee:

UMS This notation may be assigned when the arrangements are such that the ship can be operated with the machinery spaces unattended. It denotes that the control engineering equipment has been arranged, installed and tested in accordance with LR's Rules, or is equivalent thereto.

CCS This notation may be assigned when the arrangements are such that the machinery may be operated with continuous supervision from a centralised control station. It denotes that the control engineering equipment has been arranged, installed and tested in accordance with LR's Rules, or is equivalent thereto.

ICC This notation may be assigned when the arrangements are such that the control and supervision of ship operational functions are computer based. It denotes that the control engineering equipment has been arranged, installed and tested in accordance with LR's Rules, or is equivalent thereto.

IP This notation may be assigned to a ship classed with LR when the arrangements of the machinery are such that the propulsion equipment and all the essential auxiliary machinery is integrated with the power unit for operation under all normal sea-going and manoeuvring conditions. The system is to be bridge controlled and the propulsion equipment is to incorporate an emergency

means of propulsion in the event of failure in the prime mover. It also denotes that the machinery and control equipment have been arranged, installed and tested in accordance with LR's Rules.

2.4.3 The following class notations are associated with dynamic positioning arrangements, and may be assigned as considered appropriate by the Classification Committee:

DP(CM) This notation may be assigned when a ship is fitted with centralised remote manual controls for position keeping and with position reference system(s) and environmental sensor(s). It denotes that the machinery and control engineering equipment has been arranged, installed and tested in accordance with LR's Rules, or is equivalent thereto.

DP(AM) This notation may be assigned when a ship is fitted with automatic main and manual standby controls for position keeping and with position reference system(s) and environmental sensor(s). It denotes that the machinery and control engineering has been arranged, installed and tested in accordance with LR's Rules, or is equivalent thereto.

DP(AA) This notation may be assigned when a ship is fitted with automatic main and automatic standby controls for position keeping and with position reference system(s) and environmental sensor(s). It denotes that the machinery and control engineering equipment has been arranged, installed and tested in accordance with LR's Rules, or is equivalent thereto.

DP(AAA) This notation may be assigned when a ship is fitted with automatic main and automatic standby controls for position keeping, together with an additional/emergency automatic control unit located in a separate compartment and with position reference systems and environmental sensors. It denotes that the machinery and control engineering equipment has been arranged, installed and tested in accordance with LR's Rules, or is equivalent thereto.

PCR(0) This rating supplements the DP() notation. This rating indicates the calculated percentage of time that a unit is capable of holding heading and position under a standard set of environmental conditions (North Sea).

Two rating numerals are calculated:

- The first numeral represents the percentage of time that the ship can remain on station when subjected to a set of standard environmental conditions (North Sea fully developed) with all thrusters operating.
- The second numeral represents the percentage of time that the ship can remain on station when subjected to a set of standard environmental conditions (North Sea fully developed) with the most effective thruster being inoperative.
- A typical rating might be (95),(70).

The foregoing dynamic positioning notations may be supplemented with a Performance Capability Rating (PCR). This rating indicates the calculated percentage of time that a ship is capable of holding heading and position under a standard set of environmental conditions (North Sea), see Pt 7, Ch 4 *Dynamic Positioning Systems*.

2.4.4 The following class notations are associated with navigation safety, and may be assigned as considered appropriate by the Classification Committee:

NAV1 This notation will be assigned when the bridge layout and level of equipment are such that the ship is considered suitable for safe periodic operation under the supervision of a single watchkeeper on the bridge. It denotes that the navigational installation has been arranged, installed and tested in accordance with LR's Rules, or is equivalent thereto.

IBS This additional notation will be assigned where an integrated bridge system is fitted to provide electronic chart display, track planning and automatic track following, centralised navigation information display, and bridge alarm management. It denotes that the integrated bridge system has been arranged, installed and tested in accordance with LR's Rules, or is equivalent thereto. For assignment of this notation, in addition to satisfying LR Rules, or equivalent thereto, for navigational function integration:

- the layout of the bridge and the equipment located on the bridge is to satisfy the requirements of a relevant International or National Ergonomic or Human-centred Design Standard, or an acceptable equivalent, to the satisfaction of LR; or
- the notation **NAV1** is also to be assigned; or
- where the bridge is not intended to operate a periodic one man watch, the layout of the bridge and the equipment on the bridge are to satisfy the requirements for the assignment of the notation **NAV1** to the satisfaction of LR with the exception of requirements identified by LR Rules that may be relaxed in such cases.

2.4.5 Machinery class notations will not be assigned to ships the hulls of which are not classed or intended to be classed with LR.

2.4.6 The notations **LMC**, [**LMC**], **LMC** and **MCH** will, in general, not be assigned to non-propelled craft, but individual cases will be considered on their merits.

Table 2.2.4 Machinery Class Notations

Machinery Notations		
See Pt 1, Ch 2, 2.4 Class notations (machinery), Pt 1, Ch 2, 2.5 Class notations (machinery special features), Pt 1, Ch 2, 2.6 Class notations (refrigerated cargo installations (RMC), controlled atmosphere (CA) systems and carriage of refrigerated containers (CRC))		
⌘ LMC Propulsion and essential machinery	OPS Operation of Services by connection to an external electrical Power Supply	⌘ Lloyd's LMC Refrigerated Machinery
[⌘] LMC Propulsion and essential machinery	PM Positional Mooring System	Lloyd's LMC Refrigerated Machinery
⌘ LMC Propulsion and essential machinery	PMC Positional Mooring System for mooring in Close proximity to other vessels or installations	‡ Double Dagger – Suitable for carriage of fruit
MCH Propulsion and essential machinery	LFPF() Machinery installation fuelled by low flashpoint fuel	⌘ Lloyd's RMC (LG) Reliquefaction and/or refrigeration equipment is fitted
IGS Inert Gas System	PMR Propulsion System Redundancy	Lloyd's RMC (LG) Reliquefaction and/or refrigeration equipment is fitted
UMS Unattended Machinery Spaces	PSMR Propulsion and Steering System Redundancy	⌘ Lloyd's RMC (BC) Refrigerated Chemical tanker
CCS Centralised Control Station	PSMR* Propulsion and Steering System Redundancy in Separate Compartments	Lloyd's RMC (BC) Refrigerated Chemical Tanker
ICC Integrated Computer Control	PMRL Propulsion System Redundancy with Limited Capacity	TC Chemical Tanker temperature Control Systems
IP Integrated Propulsion	PMRL* Propulsion System Redundancy in Separate Compartments with Limited Capacity	(CA) Controlled Atmosphere
DP(CM) Dynamic Position (Centralised Remote Manual Controls)	SMRL Steering System Redundancy with Limited Capacity	CA (%O₂, %CO₂) Controlled Atmosphere
DP(AM) Dynamic Position (Automatic main and Manual standby Controls)	SMRL* Steering System Redundancy in Separate Compartments with Limited Capacity	RH Relative Humidity
DP(AA) Dynamic Position (Automatic main and Automatic standby Controls)	PSMRL Propulsion and Steering System Redundancy with Limited Capacity	
DP(AAA) Dynamic Positioning (Automatic main and Automatic standby controls with additional/emergency Automatic control)	PSMRL* Propulsion and Steering System Redundancy in Separate Compartments with Limited Capacity	
PCR(0) Performance Capability Rating	CAC1(1 or 2 or 3) Crew Accommodation Comfort	

NAV1 Navigation Equipment	PAC1 (or 2 or 3) Passenger Accommodation Comfort
IBS Integrated Bridge System	PCAC1 (or 2 or 3), 1 (or 2 or 3) Passenger and Crew Accommodation

2.5 Class notations (machinery special features)

2.5.1 The following class notation is associated with onshore power supply arrangements and may be assigned as considered appropriate by the Classification Committee, upon application from the Owners:

OPS Assigned when the machinery, electrical and control engineering arrangements installed on board to permit continued operation of services by connection to an external electrical power supply have been assessed.

2.5.2 The following class notations are associated with positional mooring systems, or thruster-assisted positional mooring systems, and may be assigned as considered appropriate by the Classification Committee:

PM Assigned when a positional mooring system is fitted. It is not intended to apply to vessels which have station-keeping capabilities, but which are not required to remain on station in adverse weather conditions. This notation can be supplemented by a Thrust-Assisted notation **(T1)** [or **(T2)** or **(T3)**].

PMC Assigned when a positional mooring system for mooring in close proximity to other vessels or installations is fitted. It is not intended to apply to vessels which have station-keeping capabilities, but which are not required to remain on station in adverse weather conditions. This notation can be supplemented by a Thrust-Assisted notation **(T1)** [or **(T2)** or **(T3)**].

2.5.3 The following class notations are associated with machinery redundancy and may be assigned as considered appropriate by the Classification Committee:

PMR This notation will be assigned where the main propulsion systems are arranged such that, in the event of a single failure in equipment, the ship will retain not less than 50 per cent of the installed prime mover capacity and not less than 50 per cent of the installed propulsion systems. It also denotes that the installation has been arranged, installed and tested in accordance with LR Rules.

PMR* This notation will be assigned where the main propulsion systems are arranged such that, in the event of a single failure in equipment, the ship will retain not less than 50 per cent of the installed prime mover capacity and not less than 50 per cent of the installed propulsion systems and where the machinery is installed in separate compartments such that, in the event of the loss of one compartment, the ship will retain availability of propulsion power. It also denotes that the installation has been arranged, installed and tested in accordance with LR Rules.

SMR This notation will be assigned where the steering systems for manoeuvring are arranged so that steering capability will continue to be available in the event of a single failure in the steering gear equipment or loss of power supply or control system for any steering system. It also denotes that the installation has been arranged, installed and tested in accordance with LR's Rules.

SMR* This notation will be assigned where the steering systems for manoeuvring are arranged so that steering capability will continue to be available in the event of a single failure in the steering gear equipment or loss of power supply or control system for any steering system and where the steering systems are installed in separate compartments such that, in the event of the loss of one compartment, steering capability will continue to be available. It also denotes that the installation has been arranged, installed and tested in accordance with LR's Rules.

PSMR This notation will be assigned where the main propulsion and steering systems are configured such that, in the event of a single failure in equipment, the ship will retain not less than 50 per cent of the installed prime mover capacity and not less than 50 per cent of the installed propulsion systems and retain steering capability. It also denotes that the installation has been arranged, installed and tested in accordance with LR's Rules.

PSMR* This notation will be assigned where the main propulsion and steering systems are configured such that, in the event of a single failure in equipment, the ship will retain not less than 50 per cent of the installed prime mover capacity and not less than 50 per cent of the installed propulsion systems and retain steering capability. The propulsion and steering arrangements are to be installed in separate compartments such that, in the event of the loss of one compartment, the ship will retain availability of propulsion power and manoeuvring capability. It also denotes that the installation has been arranged, installed and tested in accordance with LR's Rules.

The foregoing machinery redundancy notations may be supplemented with the additional **L** character which indicates a limited capability.

2.5.4 The following class notations are associated with comfort control and may be assigned as considered appropriate by the Classification Committee:

CAC1 (or **2** or **3**)

Assigned when noise and vibration levels in crew accommodation and work areas have been assessed. Numerals **1** or **2** or **3** indicate the acceptance criterion to which the noise and vibration levels have been assessed. Primarily intended to apply to passenger ships. If requested, however, any ship can be assessed for compliance.

PAC1 (or **2** or **3**)

Assigned when noise and vibration levels in passenger accommodation have been assessed. Numerals **1** or **2** or **3** indicate the acceptance criterion to which the noise and vibration levels have been assessed. Primarily intended to apply to passenger ships. If requested, however, any ship can be assessed for compliance.

PCAC1 (or **2** or **3**), (**1** or **2** or **3**)

Assigned when noise and vibration levels in passenger and crew spaces have been assessed. Numerals **1** or **2** or **3** indicate the acceptance criterion to which the noise and vibration levels have been assessed. Two numerals will be assigned, the first for the acceptance criteria for passenger accommodation, the second for crew comfort criteria. Primarily intended to apply to passenger ships. If requested, however, any ship can be assessed for compliance.

2.5.5 The following class notation is associated with low flashpoint fuelled vessels and may be assigned as considered appropriate by the Classification Committee:

LFPF() Assigned where the main propelling and/or auxiliary machinery is designed to operate using a low flashpoint fuel in accordance with the applicable LR Rules and Regulations. As a minimum, the **LFPF()** notation is to be appended by associated characters **GC** or **GF** and one two letter fuel identifier, and will be entered in column 4 of the *Register Book*;

GC Assigned to liquefied gas carriers or tankers, where the main propelling and/or auxiliary machinery is designed to operate on a low flashpoint fuel. The notation also indicates that the gas-fuelled machinery has been constructed, arranged, installed and tested in accordance with the relevant requirements of *Use of Cargo as Fuel* of LR's Rules for Ships for Liquefied Gases, or is equivalent thereto.

GF Assigned to ships other than liquefied gas carriers or tankers, where the main propelling and/or auxiliary machinery is designed to operate on a low flashpoint fuel, or a combination of low flashpoint fuel and standard marine oil fuel. The notation also indicates that the low flashpoint fuelled machinery has been constructed, arranged, installed and tested in accordance with the LR Rules and Regulations applicable to the fuel(s) used.

The low flashpoint fuel (or fuels) that the ship is designed to use is (are) indicated in the notation using a two letter identifier:

NG Natural Gas

EG Ethane Gas

LP Liquid Petroleum Gas (LPG is considered to include pure propane or Butane or any mixture of the two)

HG Hydrogen Gas

ML Methanol

2.6 Class notations (refrigerated cargo installations (RMC), controlled atmosphere (CA) systems and carriage of refrigerated containers (CRC))

2.6.1 The following class notations may be assigned as considered appropriate by the Classification Committee, on application from the Owners:

⊗ **Lloyd's RMC** This notation will be assigned when a refrigerated cargo installation has been constructed, installed and tested under LR's Special Survey and in accordance with the relevant requirements of the Rules.

Lloyd's RMC This notation will be assigned when the arrangements of the refrigerated cargo installation have been found to be equivalent to Rule requirements, and the installation has been tested in accordance with the relevant requirements of the Rules.

‡ This symbol will be assigned to installations considered suitable for the carriage of fruit. It indicates that the following parameters have been assessed and found satisfactory:

- (a) The rate of air circulation and the air refreshing arrangements through the refrigerated spaces or chambers, or to containers.
- (b) The temperature controls and monitoring arrangements.
- (c) The installation's capability to cool down a complete cargo of fruit to its carrying temperature within a specified time. The symbol will also be assigned to fishing vessels that have the refrigerating capacity to freeze down their catch.

✘ **Lloyd's RMC (LG)** This notation will be assigned to a classed liquefied gas carrier or tanker, in which reliquefaction or refrigeration equipment is approved and fitted for cargo temperature and pressure control where the equipment has been constructed, installed and tested in accordance with the relevant requirements of the Rules.

Lloyd's RMC (LG) This notation will be assigned to a classed liquefied gas carrier or tanker, in which reliquefaction or refrigeration equipment is fitted for cargo temperature and pressure control, where the equipment has been found equivalent to Rule requirements and tested in accordance with the relevant requirements of the Rules.

✘ **Lloyd's RMC (BC)** Assigned to a classed chemical tanker in which refrigeration equipment has been constructed, installed and tested, in accordance with the relevant requirements of the Rules.

Lloyd's RMC (BC) Assigned to a classed chemical tanker where the equipment has been found equivalent to Rule requirements and tested in accordance with the relevant requirements of the Rules.

TC Assigned to a classed chemical tanker where the temperature control systems have been found equivalent to Rule requirements and tested in accordance with the relevant requirements of the Rules.

2.6.2 The following class notations are associated with controlled atmospheres and may be assigned as considered appropriate by the Classification Committee, on application from Owners, *see also Pt 7, Ch 1 Controlled Atmosphere Systems*:

(CA)	This notation may be assigned when a ship is fitted with arrangements for maintaining airtightness in CA zones and for the ready connection to a gas system in accordance with the relevant requirements of the Rules.
CA (%O₂, %CO₂)	This notation may be assigned when a ship is provided with a CA system which will achieve and maintain specified ranges of oxygen and carbon dioxide levels in accordance with the relevant requirements of the Rules.
RH	This notation may be assigned when a ship can maintain a specified relative humidity in the CA zones.
RPA	Assigned to ships where the Refrigeration Machinery for Provision Stores and Air-conditioning comply with the applicable requirements of <i>Pt 7, Ch 15 Refrigeration Systems and Equipment Serving Provision Stores and Air-Conditioning Installations</i> .

Before assignment of any of the above notations it is a prerequisite that the refrigeration installation is assigned an **RMC** class notation.

2.6.3 The following class notation is associated with the carriage of refrigerated cargo containers and may be assigned as considered appropriate by the Classification Committee, on application from Owners, *see also Pt 7, Ch 10 Carriage of Refrigerated Containers*:

✘ **CRC** This notation may be assigned when a ship is provided with a ventilation system which is approved, installed and tested in accordance with the relevant requirements of the Rules.

2.6.4 The class notation assigned will additionally specify the temperature conditions and other relevant characteristics for which the equipment has been approved, *see Pt 6, Ch 3 Refrigerated Cargo Installations*.

2.6.5 The class notation assigned will be maintained as long as the installation is found, at the prescribed Periodical Surveys, to be in a fit and efficient condition, and in accordance with the requirements of the Rules.

2.6.6 The Classification Committee will give consideration to ships engaged on voyages of short duration, to installations of small capacity, or to other special circumstances. In such cases the class may include a service limitation or other restriction.

2.6.7 Refrigerating installations designed to supply refrigerated air to insulated containers in ships' holds aboard container ships, are eligible for classification. The installation is to include the refrigerating machinery, supply and return air ducting, and the flexible couplings between containers and the duct system. Where the arrangements are such that cell air conditioning is essential to the carriage of the containers, the air conditioning equipment and/or insulation of the hold, deckheads, sides and tank tops are to be included in the classification.

2.6.8 Other methods of carrying refrigerated cargoes in containers aboard container ships will be considered for classification on application.

2.7 Class notations (Environmental Protection)

2.7.1 The following class notations are associated with the design and operation of a ship and may be assigned as considered appropriate by the Classification Committee, on application from the Owners:

- ECO** This notation will be assigned when a ship is designed and operated in accordance with the relevant requirements of the Rules.
- ECO(TOC)** This notation will be assigned when the environmental protection arrangements are in accordance with the requirements of another recognised classification society and are essentially equivalent to Rule requirements and the ship is operated in accordance with the relevant requirements of the Rules.

2.8 Descriptive notes

2.8.1 In addition to any class notations, an appropriate descriptive note may be entered in column 6 of the *Register Book* indicating the type of ship in greater detail than is contained in the class notation, and/or providing additional information about the ship's design and construction. This descriptive note is not an LR class notation and is provided solely for information.

2.8.2 **ShipRight()**. Where one or more of LR's ShipRight procedures for the following have been satisfactorily applied, then a descriptive note showing the associated characters of the procedure(s) within brackets will, at the Owner's request, be entered in column 6 of the *Register Book*, preceded by the word **ShipRight**, e.g. **ShipRight(IHM, SERS)**. The requirements pertaining to these descriptive notes and the ShipRight procedures are given in *Pt 3, Ch 16 ShipRight Procedures for the Design, Construction and Lifetime Care of Ships* and *Pt 5, Ch 21 Requirements for Condition Monitoring Systems and Machinery Condition-Based Maintenance Systems*.

- BWMP()** This ShipRight descriptive note (Ballast Water Management Plan) will be assigned, when the requirements in accordance with the relevant ShipRight procedures have been complied with. The descriptive note **BWMP()** with the extension of one or more of the following associated supplementary characters shown in brackets, detailing the method(s) used, may be assigned:

- S** sequential method;
- F** flow through method;
- D** dilution method;
- T** treatment method.

- DIST()** This ShipRight descriptive note (Machinery suitable for operation on Distillate Fuels) will be assigned when specified machinery items are suitable for operation on distillate fuels, in accordance with the relevant ShipRight procedures. The **DIST()** descriptive note with the extension of one or more of the following associated supplementary characters shown in brackets, detailing the specified machinery items, may be assigned:

- M** main engine(s);
- AB** auxiliary engines and boiler;
- I** incinerator;
- IG** inert gas generator.

- E** This ShipRight descriptive note (Evidence) will be assigned, where evidence exists that supporting calculations have been performed in accordance with hull structural finite element and fatigue analysis procedures of a recognised classification society. This descriptive note can be assigned to vessels transferring class or to new builds where the design has been appraised by another recognised classification society.

- ES()** This ShipRight descriptive note (Enhanced Scantlings) will be assigned, where scantlings in excess of the approved Rule minimum are fitted at defined locations in accordance with the relevant ShipRight procedures. The added thickness measurement in mm is to be shown with a description of the location(s) in brackets e.g. **ShipRight(ES(+1 Strength Deck, +2 Bottom Shell))**.

- IHM** This ShipRight descriptive note (Inventory of Hazardous Materials) will be assigned when the requirements in accordance with the relevant ShipRight procedures have been complied with.

- PCWBT()** This ShipRight descriptive note (Protection Coatings in Water Ballast Tanks) will be assigned, to indicate that all sea-water ballast spaces having boundaries formed by the hull envelope have a corrosion protection coating applied, and that the coating remains efficient and is maintained in good condition. The month and year that the coating is approved is to be appended to the descriptive note within brackets.

- SEA()** This descriptive note (Ship Event Analysis) will be assigned, where hull surveillance systems for monitoring of the ship's hull girder stresses and motions have been fitted and are in compliance with the relevant ShipRight procedures. The ShipRight descriptive note is to be appended by **HSS** followed by the number of strain gauges fitted shown in brackets. In addition the extension of one or more of the following associated supplementary characters may be shown e.g. **ShipRight(SEA(HSS-2, VDR))**:
- L** The display of the relevant information in the cargo control area;
 - M** The display and recording of the ship's motion;
 - N** The facility to display and record navigational information;
 - VDR** An interface with the ship's voyage data recorder system to enable the recording of hull stress, ship motion and hull pressure information.
- SEA ICE** This ShipRight descriptive note (Ship Event Analysis Ice) will be assigned when the ship has been provided with a hull surveillance system that can display and record local ice load induced stresses from a series of strain gauges in the bow region.
- SERS** This ShipRight descriptive note (Ship Emergency Response Service) will be assigned when a Ship is registered with LR's Ship Emergency Response Service.
- SCM** This ShipRight descriptive note (Screwshaft Condition Monitoring) will be assigned where an Owner adopts the requirements for monitoring of the screwshaft. The descriptive note will indicate that equipment and procedures are in place to determine the physical and operational condition of that equipment.
- SRtP** This ShipRight descriptive note (Safe Return to Port and Orderly Evacuation) is to be applied where the design appraisal and survey of the vessel has been performed in accordance with the relevant ShipRight procedures for vessels required to comply with Safe Return to Port and Orderly Evacuation.
- TCM** This ShipRight descriptive note (Main Steam Turbine Condition Monitoring) will be assigned where an Owner adopts the requirements for monitoring of the main steam turbine. The descriptive note will indicate that equipment and procedures are in place to determine the physical and operational condition of that equipment. Further information is provided in the LR document *ShipRight Procedure Machinery Planned Maintenance and Condition Monitoring*.
- MCM** This ShipRight descriptive note (Machinery Condition Monitoring) will be assigned where an Owner operates an approved Planned Maintenance Scheme as part of the Continuous Survey Machinery (CSM) cycle, and monitoring techniques and equipment are used to record the condition against agreed acceptable limits. The descriptive note will indicate that equipment, procedures and documentation are in place to monitor, control and record the physical and operational condition of the equipment on the ship and control the maintenance routines accordingly. For the design and installation of machinery condition monitoring systems which form part of a machinery planned maintenance scheme approved by LR for the assignment of the descriptive note, the requirements of *Pt 5, Ch 21 Requirements for Condition Monitoring Systems and Machinery Condition-Based Maintenance Systems* are applicable.
- MCBM** This ShipRight descriptive note (Machinery Condition-Based Maintenance) will be assigned where an Owner operates an approved Planned Maintenance Scheme based on the use of Condition-based Maintenance as part of the Continuous Survey Machinery (CSM) cycle. The descriptive note will indicate that procedures and documentation are in place to control and record the inspection and maintenance routines of all surveyable machinery and equipment. The Scheme is to be based on acceptable and applicable modes of failure analysis and risk assessment approved by LR. For the design and installation of machinery condition monitoring systems which form part of a Machinery Condition based Maintenance scheme approved by LR for the assignment of the descriptive note, the requirements of *Pt 5, Ch 21 Requirements for Condition Monitoring Systems and Machinery Condition-Based Maintenance Systems* are applicable.
- MPMS** This ShipRight descriptive note (Machinery Planned Maintenance Scheme) will be assigned where an Owner operates an approved Machinery Planned Maintenance Scheme as part of the Continuous Survey Machinery (CSM) cycle. The descriptive note will indicate that procedures and documentation are in place to control and record the inspection and maintenance routines of all machinery and equipment in the ship.
- RCM** This ShipRight descriptive note (Reliability Centred Maintenance) will be assigned where an Owner operates an approved Planned Maintenance Scheme based on the use of Reliability Centred Maintenance as part of the Continuous Survey Machinery (CSM) cycle. The descriptive note will indicate that procedures and documentation are in place to control and record the inspection and maintenance routines of all machinery and equipment in the ship, and that they are based on acceptable and applicable methodology.

VECS This ShipRight descriptive note (Vapour Emission Control System) will be assigned to a ship that has a vapour emission control system fitted which has been designed and constructed in accordance with the requirements of USCG 46, CFR 39 or the IMO Standards for Vapour Emission Control Systems (MSC Circular 585).

VECS-L This ShipRight descriptive note (Vapour Emission Control System – Lightering) will be assigned to a ship that has a vapour emission control system that complies with the requirements for the **VECS** Descriptive Note and which has also been designed and constructed to meet the requirements for vapour balancing in accordance with USCG 46, CFR 39.40 for service vessels. If a ship has been assigned the **ECO** notation then it will not be eligible for the **VECS-L** Descriptive Note. Instead, **VECS** for lightering will be referenced in the **ECO** notation, i.e. **ECO(VECS-L)**.

2.8.3 Where an approved loading instrument is provided as an Owner's requirement, a descriptive note **LI** may be entered in column 6 of the *Register Book*, see also *Pt 1, Ch 2, 2.3 Class notations (hull) 2.3.16*.

2.8.4 Where container securing arrangements are designed and constructed in accordance with *Pt 3, Ch 14 Cargo Securing Arrangements*, but where the Initial and Periodical Survey requirements for loose fittings are not requested, the ship will be eligible to be assigned the descriptive note **CSA** (container securing arrangement) and for an entry to be made in column 6 of the *Register Book*.

2.8.5 **EDD**. Vessel is eligible for the Owner/Operator to apply to the Flag Administration for the vessel to be placed on a pilot Extended Dry-Docking regime. The relevant Flag Administration may elect to impose requirements additional to those defined as per this descriptive note. Vessels are to comply with the LR Guidance notes on Extended Dry- Dockings.

2.8.6 **STV**. Where a sailing vessel is used for the offshore training of cadets or trainee seamen, a sailing training vessel **STV** descriptive note may be entered in column 6 of the *Register Book*.

2.8.7 **GR**. Assigned to ships other than LNG carriers, detailing the aspects of design and construction that are prepared for gas fuel operation in accordance with LR's Rules and Regulations in force on the date of 'contract for construction'. If a ship has been assigned the **LFPF(GF, NG)** notation then it will not be eligible for the **GR** descriptive note. The descriptive note **GR**, with the extension of one or more of the following associated characters shown in brackets, may be entered in column 6 of the *Register Book*.

A	The design of the gas fuel system has been approved in principle.
S	Enhanced structural reinforcement and appropriate materials have been fitted to support the proposed gas storage tank.
T	Fuel storage arrangements installed in accordance with an approved design.
P	Gas fuel piping arrangements installed in accordance with an approved design.
E	Engineering systems have been installed in accordance with an approved design. Additional letters will be assigned in brackets to identify which items may be gas-fuelled:
	M = main engine(s)
	A = auxiliary engines
	B = boiler
	I = incinerator

See LR's *Rules and Regulations for the Classification of Natural Gas Fuelled Ships, Ch 1, 1.2 Class notation and descriptive note* for further detail.

2.9 Application notes

2.9.1 **Propelling and essential auxiliary machinery** includes machinery, equipment and systems installed for the ship to be under seagoing conditions and that are necessary for the following:

- Maintaining the watertight and weathertight integrity of the hull and spaces within the hull.
- The safety of the ship, machinery and personnel on board.
- The functioning and dependability of propulsion, steering and electrical systems.
- The operation and functioning of control engineering systems for the monitoring and safety of propulsion and steering systems.
- The operation and functioning of emergency machinery and equipment.

2.9.2 **Manufacturer's certificate** for assignment of the [✖] **LMC** notation. Acceptance of the manufacturer's certificate for items of machinery for propulsion (including propulsion gearing with single input/output arrangements) and for electrical power generation and for other auxiliary machinery for essential services is subject to the following:

- (a) The ship is a cargo ship of less than 500 gross tonnage or is a ship of 500 gross tonnage or greater and is not required to comply with international conventions applicable to a ship with unrestricted service.
- (b) Propulsion power is provided by oil engines or gas turbines which have been type approved in accordance with LR requirements for marine application.
- (c) Electrical power is provided by generators driven by oil engines or gas turbines which have been type approved in accordance with LR requirements for marine application.
- (d) The design and manufacture standards for all machinery and associated engineering systems are the applicable LR Rules.
- (e) The machinery and equipment is manufactured under a recognised quality control system.
- (f) Propellers, propulsion shafting and multiple input/output gearboxes are not included within the scope of propulsion arrangements for acceptance of a manufacturer's certificate.

2.9.3 **Manufacturer's certificate** for assignment of the **MCH** notation. Acceptance of the manufacturer's certificate for propelling and essential auxiliary machinery is subject to the following:

- (a) The ship is a cargo ship of less than 500 gross tonnage or is a ship of 500 gross tonnage or greater and is not required to comply with the international conventions applicable to a ship with unrestricted service.
- (b) Propulsion power is provided by oil engines or gas turbines which have been type approved in accordance with LR requirements for marine application.
- (c) Electrical power is provided by generators driven by oil engines or gas turbines which have been type approved in accordance with LR requirements for marine application.
- (d) The power of any prime mover is less than 2,250 kW and the cylinder bore or any diesel engine is not greater than 300 mm.
- (e) The design and manufacture standards for machinery and associated systems are the applicable LR Rules or other marine standards acceptable to LR.
- (f) The machinery and equipment is manufactured under a recognised quality control system in accordance with the requirements of LR's *Rules for the Manufacture, Testing and Certification of Materials, July 2015*.
- (g) Individual components manufactured under *Pt 1, Ch 2, 2.9 Application notes 2.9.3* are to be delivered with a manufacturer's statement confirming that the scantlings comply with the applicable LR Rule requirements.

■ *Section 3*

Surveys - General

3.1 Statutory surveys

3.1.1 The Classification Committee will act, when authorised on behalf of Governments, in respect of National and International statutory safety and other requirements for passenger and cargo ships.

3.1.2 The Classification Committee will also act, when authorised, in respect of National Safety and other requirements relating to ships used for offshore mineral exploration and exploitation.

3.2 New construction surveys

3.2.1 When it is intended to build a ship for classification with LR, constructional plans and all necessary particulars relevant to the hull, equipment and machinery, as detailed in the Rules, are to be submitted for approval before the work is commenced. Proposals for any subsequent modifications or additions to the scantlings, arrangements or equipment shown on the approved plans are also to be submitted in writing and on plans for approval.

3.2.2 Where the proposed construction of any part of the hull or machinery is of novel design, or involves the use of unusual material, or where experience, in the opinion of the Classification Committee, has not sufficiently justified the principle or mode of application involved, special tests or examinations before and during service may be required. In such cases a suitable notation may be assigned.

3.2.3 The materials used in the construction of hulls and machinery intended for classification are to be of good quality and free from defects and are to be tested in accordance with the requirements of the *Rules for the Manufacture, Testing and*

Certification of Materials, July 2015. The steel is to be manufactured by an approved process at an approved works. Alternatively, tests will be required to demonstrate the suitability of the steel.

3.2.4 New ships intended for classification are to be built under LR's Special Survey. From the commencement of the work until the completion of the ship, the Surveyors are to be satisfied that the materials, workmanship and arrangements are satisfactory and in accordance with the Rules. Any items found not to be in accordance with the Rules or the approved plans, or any material, workmanship or arrangements found to be unsatisfactory, are to be rectified.

3.2.5 For compliance with *Pt 1, Ch 2, 3.2 New construction surveys 3.2.4*, LR is prepared to consider methods of survey and inspection for hull construction which formally include procedures involving the shipyard management, organisation and quality systems. The minimum requirements for the approval of any such proposed Quality Assurance methods are laid down in *Pt 3, Ch 15 Quality Assurance Scheme for the Hull Construction of Ships*.

3.2.6 Each offshore supply ship, offshore tug/supply ship, dredger, hopper dredger, sand carrier, hopper barge or reclamation craft, proceeding to sea is to comply with the draught and stability requirements of the National Authority and is to have on board sufficient stability data to enable it to be properly loaded and handled, or, where appropriate, to be properly towed. This data is to take full account of any intended special distribution or concentration of loading. In the case of an unmanned ship under tow, the data is to be made available to the tug master.

3.2.7 Copies of approved plans (showing the ship as built), essential certificates and records, required loading and other instruction manuals are to be readily available for use when required by the attending Surveyors, and may be required to be kept on board.

3.2.8 When the machinery is constructed under LR's Special Survey, this survey is to relate to the period from the commencement of the work until the final test under working conditions. Any items found not to be in accordance with the Rules or the approved plans, or any material, workmanship or arrangements found to be unsatisfactory, are to be rectified.

3.2.9 When arrangements are such that essential machinery can be operated by remote and/or automatic control equipment, the control equipment is to be arranged, installed and tested in accordance with LR's Rules and Regulations.

3.2.10 The date of completion of the Special Survey during construction of ships built under LR's inspection will normally be taken as the date of build to be entered in the *LR Publication Record*. If the period between launching and commissioning is, for any reason, unduly prolonged, the dates of launching and completion or commissioning may be separately indicated in the *LR Publications*.

3.2.11 When a ship, upon completion, is not immediately commissioned but is laid-up for a period, the Classification Committee, upon application by the Owner, prior to the ship proceeding to sea, will direct an examination to be made by the Surveyors which may include a survey in dry-dock. If, as the result of such a survey, the hull and machinery be reported in all respects in accordance with applicable Rule requirements, the subsequent Special Survey and Complete Survey of the machinery will date from the time of such examination.

3.3 Existing ships

3.3.1 **Classification of ships not built under survey.** The requirements of the Classification Committee for the classification of ships which have not been built under LR's Survey are indicated in *Pt 1, Ch 3, 19 Classification of ships not built under survey*. Special consideration will be given to ships transferring class to LR from another recognised Classification Society.

3.3.2 **Reclassification.** When reclassification or class reinstatement is desired for a ship for which the class previously assigned by LR has been withdrawn or suspended, the Classification Committee will direct that a survey, appropriate to the age of the ship and the circumstances of the case, be carried out by the Surveyors. If, at such a survey, the ship be found or placed in a condition in accordance with the requirements of the Rules and Regulations, the Classification Committee will be prepared to consider reinstatement of the original class or the assignment of such other class as may be deemed necessary.

3.3.3 A similar arrangement will apply in the case of reclassification of refrigerated cargo installations.

3.3.4 The Classification Committee reserves the right to decline an application for classification or reclassification where the prior history or condition of the ship indicates this to be appropriate.

3.3.5 **Unscheduled surveys.** Where the Classification Committee has concern about the condition of a ship and/or the equipment an unscheduled survey may be required at any time to determine the actual condition.

3.4 Damages, repairs and alterations

3.4.1 All repairs to hull, equipment and machinery which may be required in order that a ship may retain her class (*see Pt 1, Ch 2, 1.1 General 1.1.5*), are to be carried out to the satisfaction of the Surveyors. When repairs are effected at a port, terminal or

location where the services of a Surveyor to LR are not available, the repairs are to be surveyed by one of the Surveyors at the earliest opportunity thereafter.

3.4.2 When, at any survey, the Surveyors consider repairs to be immediately necessary, either as a result of damage, or wear and tear, they are to communicate their recommendations at once to the Owner, or his representative. When such recommendations are not complied with, immediate notification is to be given to the Classification Committee by the Surveyors.

3.4.3 Where repairs are to be carried out by a riding crew during a voyage then these must be planned in advance. A complete repair procedure, including the extent of proposed repair and the need for Surveyor's attendance during the voyage, is to be submitted reasonably in advance to the Surveyor for agreement. Failure to notify LR in advance of the repairs may result in the class of the ship being specially considered by the Classification Committee. Where emergency repairs are effected immediately due to an extreme emergency circumstance, the repairs should be documented in the ship's log and submitted thereafter to LR for use in determining further survey requirements.

3.4.4 When, at any survey, it is found that any damage, defect or breakdown (*see Pt 1, Ch 2, 1.1 General 1.1.5*) is of a nature that does not require immediate permanent repair, but is sufficiently serious to require rectification by a prescribed date in order to maintain class, a suitable condition of class is to be imposed by the Surveyors and recommended to the Classification Committee for consideration.

3.4.5 If a ship which is classed with LR is to leave harbour limits or protected waters under tow, the Owner is to advise LR of the circumstances prior to her departure.

3.4.6 If a ship which is classed with LR is taken in tow whilst at sea, the Owner is to advise LR of the circumstances at the first practicable opportunity.

3.4.7 Plans and particulars of any proposed alterations to the approved scantlings and arrangements of hull, equipment, or machinery are to be submitted for approval, and such alterations are to be carried out to the satisfaction of the Surveyors.

3.4.8 Where a complete replacement or addition of a major portion of the ship is involved, as defined in *Pt 1, Ch 2, 3.4 Damages, repairs and alterations 3.4.9*, consideration may be given to assignment of a separate date of build for the new structure. The Survey requirements shall be based on the date of build associated with each major portion of the ship. Special Survey due dates may be aligned at the discretion of the Committee.

3.4.9 A major portion of the ship may include a complete forward or after section, a complete main cargo section (which may include a complete hold/tank of a cargo ship), a complete block of deck structure of a passenger ship or a structural modification of a single hull to a double hull ship.

3.5 Existing ships – Periodical Surveys

3.5.1 Annual Surveys are to be held on all ships within three months, before or after each anniversary of the completion, commissioning or Special Survey in accordance with the requirements given in *Pt 1, Ch 3 Periodical Survey Regulations*. The date of the last Annual Survey will be recorded on the Class Direct website.

3.5.2 Intermediate Surveys are to be held on all ships instead of the second or third Annual Survey after completion, commissioning or Special Survey. The Intermediate Survey may be commenced at the second Annual Survey and progressed with completion at the third Annual Survey. The date of the last Intermediate Survey will be recorded on the Class Direct website. The concurrent crediting of items towards both Intermediate Survey and Special Survey is not permitted.

3.5.3 The Owner should notify LR whenever a ship can be examined in dry dock or on a slipway. A minimum of two Docking Surveys are to be held in each five-year Special Survey period and the maximum interval between successive Docking Surveys is not to exceed three years. One of the two Docking Surveys required in each five-year period is to coincide with the Special Survey. Consideration may be given in exceptional circumstances to an extension of the Docking Survey, not exceeding three months, provided the interval between successive surveys does not exceed 36 months. A definition of 'exceptional circumstances' is given in *Pt 1, Ch 2, 3.5 Existing ships – Periodical Surveys 3.5.9*. The Classification Committee may accept an In-water Survey in lieu of the intermediate docking between Special Surveys, *see Pt 1, Ch 3, 4.3 In-water Surveys*.

An In-water Survey shall not be permitted for ships of 15 years of age and over that are assigned the notation **ESP**. A Docking Survey is considered to coincide with the Special Survey when held within the 15 months prior to the due date of the Special Survey.

Where the Special Survey of the hull is carried out on a Continuous Survey basis, as given in *Pt 1, Ch 2, 3.5 Existing ships – Periodical Surveys 3.5.14*, the survey in dry dock may be held at any time within the five-year cycle.

3.5.4 The interval between dry-dockings for ships operating in fresh water and for certain non-self-propelled craft may be greater than that given in *Pt 1, Ch 2, 3.5 Existing ships – Periodical Surveys 3.5.3*.

3.5.5 Attention is to be given to any relevant statutory requirements of the National Authority of the country in which the ship is registered.

3.5.6 The date of the last examination in dry-dock or on a slipway will be recorded on the Class Direct website.

3.5.7 As an alternative to Annual Surveys and Docking Surveys, according to *Pt 1, Ch 2, 3.5 Existing ships – Periodical Surveys 3.5.1* and *Pt 1, Ch 2, 3.5 Existing ships – Periodical Surveys 3.5.3* respectively, ships classed '100A1 shipborne barge' may be subjected to Intermediate Surveys. These surveys become due 30 months after the previous Special Survey. The survey is to be in accordance with the requirements given in *Pt 1, Ch 3, 2 Annual Surveys - Hull and machinery requirements*, as applicable. Intermediate Surveys are to be completed within three months of the due date.

3.5.8 Survey requirements for In-water Surveys are given in *Pt 1, Ch 3, 4.3 In-water Surveys*. The date of the last In-water Survey will be recorded on the Class Direct website.

3.5.9 All ships classed with LR are also to be subjected to Special Surveys in accordance with the requirements given in *Pt 1, Ch 3 Periodical Survey Regulations*. These Surveys become due at five-yearly intervals, the first one five years from the date of build or date of Special Survey for Classification as recorded in the *Register Book*, and thereafter five years from the date recorded for the previous Special Survey. Consideration may be given at the discretion of the Committee to any exceptional circumstances justifying an extension of the hull classification to a maximum of three months beyond the fifth year. If an extension is agreed the next period of hull classification will start from the due date of the Special Survey before the extension was granted. In this context 'exceptional circumstances' means unavailability of dry-docking facilities, repair facilities, essential materials, equipment or spare parts or delays incurred by action taken to avoid severe weather conditions.

3.5.10 Where, on shipborne barges, Intermediate Surveys are permitted as an alternative to Annual and Docking Surveys, Special Surveys become due five years after the previous Special Survey.

3.5.11 Special Surveys may be commenced at the fourth Annual Survey after completion, commissioning, or previous Special Survey, and be progressed during the succeeding year with a view to completion by the due date of the Special Survey.

3.5.12 When Special Surveys are commenced prior to the fourth Annual Survey, the entire survey is to be completed within 15 months if such work is to be credited towards the Special Survey.

3.5.13 Ships which have satisfactorily passed a Special Survey will have a record entered in the *Register Book* indicating the date and the notation **ESP** if this is applicable see *Pt 1, Ch 2, 2.3 Class notations (hull) 2.3.12*. Where the Special Survey is completed more than three months before the due date, the new record of Special Survey will be the final date of survey.

(a) In all other cases, with the exception of *Pt 1, Ch 2, 3.5 Existing ships – Periodical Surveys 3.5.13*, the date recorded will be the fifth anniversary of the previous Special Survey.

(b) For ships registered with Flag Administrations that have neither implemented the International Convention for the Safety of Life at Sea (SOLAS 1974) Harmonised System of Survey and Certification (HSSC) under the Protocol of 1988, nor adopted HSSC under *IMO Resolution A.883(21) – Global and Uniform Implementation of the Harmonized System of Survey and Certification (HSSC) – (Adopted on 25 November 1999)*, where the Special Survey is completed before the due date, the new record will be the final date of survey.

3.5.14 At the request of an Owner, it may be agreed that the Special Survey of the hull, for ships other than general dry cargo ships, bulk carriers, combination carriers, chemical tankers and oil tankers, be carried out on the Continuous Survey basis, all compartments of the hull being opened for survey and testing, in rotation, with an interval of five years between consecutive examinations of each part. In general, approximately one fifth of the Special Survey is to be completed each year and all the requirements of the particular hull Special Survey must be completed at the end of the five-year cycle. For examination of items listed in *Pt 1, Ch 3, 2.2 Annual Surveys 2.2.24*, *Pt 1, Ch 3, 2.2 Annual Surveys 2.2.29* and *Pt 1, Ch 3, 3.2 Intermediate Surveys 3.2.6*, *Pt 1, Ch 3, 3.2 Intermediate Surveys 3.2.7* and *Pt 1, Ch 3, 3.2 Intermediate Surveys 3.2.9*, the intervals for inspection will require to be specially agreed. For ships more than 10 years of age, an examination of the ballast tanks is to be carried out twice in each five year cycle, i.e. once within the scope of the Intermediate Survey and once within the scope of the Continuous Survey. Ships which have satisfactorily completed the cycle will have a record entered in the Class Direct indicating the date of completion which will not be later than five years from the last assigned date of Complete Survey of the hull. The agreement for surveys to be carried out on Continuous Survey basis may be withdrawn at the discretion of the Classification Committee.

3.5.15 In cases where the ship has been laid up or has been out of service for a considerable period because of a major repair or modification and the Owner elects to only carry out the overdue surveys, the next period of class will start from the expiry date of the Special Survey. If the Owner elects to carry out the next due Special Survey, the period of class will start from the survey completion date.

3.5.16 Machinery is to be submitted to the surveys detailed in *Pt 1, Ch 3, 11 Machinery surveys - General requirements to Pt 1, Ch 3, 17 Screwshafts, tube shafts and propellers*.

3.5.17 In cases where the ship has been laid-up, or has been out of service for a considerable period because of a major repair or modification and the Owner elects to only carry out the overdue surveys, the next period of class will start from the expiry date of the last Complete Survey of machinery. If the Owner elects to carry out a Complete Survey, the period of class will start from the completion date of this survey.

3.5.18 Complete Surveys of machinery become due at five-yearly intervals, the first one five years from the date of build or date of first classification as recorded in Class Direct , and thereafter five years from the date recorded for the previous Complete Survey. Consideration can be given at the discretion of the Classification Committee to any exceptional circumstances justifying an extension of machinery class to a maximum of three months beyond the fifth year. If an extension is agreed, the next period of machinery class will start from the due date of Complete Survey of machinery before extension was granted. Surveys which are commenced prior to their due date are not to extend over a period greater than 15 months, except with the prior approval of the Classification Committee. Where the survey is completed more than three months before the due date, the recorded date of completion will be the final date of survey.

- (a) In all other cases, with the exception of *Pt 1, Ch 2, 3.5 Existing ships – Periodical Surveys 3.5.18*, the date recorded will be the fifth anniversary of the previous Complete Survey of machinery.
- (b) For ships registered with Flag Administrations that have neither implemented the International Convention for the Safety of Life at Sea (SOLAS 1974) Harmonised System of Survey and Certification (HSSC) under the Protocol of 1988, nor adopted HSSC under *IMO Resolution A.883(21) – Global and Uniform Implementation of the Harmonized System of Survey and Certification (HSSC) – (Adopted on 25 November 1999)*, where the Survey is completed before the due date, the new record will be the final date of survey.

3.5.19 Upon application by an Owner, the Classification Committee may agree to an extension of the survey requirements for main engines, which, by the nature of the ship's normal service, do not attain the number of running hours recommended by the engines' manufacturer for major overhauls within the survey periods given in *Pt 1, Ch 2, 3.5 Existing ships – Periodical Surveys 3.5.18*.

3.5.20 If it is found desirable that any part of the machinery should be examined again before the due date of the next survey, a certificate for a limited period will be granted in accordance with the nature of the case.

3.5.21 When, at the request of an Owner, it has been agreed by the Classification Committee that the Complete Survey of the machinery may be carried out on the Continuous Survey basis, the various items of machinery are to be opened for survey in rotation, as far as practicable, to ensure that the interval between consecutive examinations of each item will not exceed five years. In general, approximately one-fifth of the machinery is to be examined each year.

3.5.22 If any examination during Continuous Survey reveals defects, further parts are to be opened up and examined as considered necessary by the Surveyor, and the defects are to be made good to his satisfaction.

3.5.23 Upon application by an Owner, the Classification Committee may agree to an arrangement whereby, subject to certain conditions, some items of machinery may be examined by the Chief Engineer of the ship at ports where LR is not represented, or, where practicable, at sea, followed by a limited confirmatory survey carried out at the next port of call where an Exclusive Surveyor is available. Particulars of this arrangement may be obtained from LR. Where an approved planned maintenance scheme is in operation, the confirmatory surveys may be held at annual intervals, at which time the records will be checked and the operation of the scheme verified. Particulars of this arrangement may be obtained from any LR Office.

3.5.24 Where condition monitoring equipment is fitted, the Classification Committee, upon application by the Owner, will be prepared to amend applicable Periodical Survey requirements where details of the equipment are submitted and found satisfactory. Where machinery installations are accepted for this method of survey, it will be a requirement that an Annual Survey be held, at which time monitored records will be analysed and the machinery examined under working conditions. An acceptable lubricating oil trend analysis programme may be required as part of the condition monitoring procedures.

3.5.25 Boiler Surveys, examination of steam pipes and Screwshaft Surveys are to be carried out as stated in *Pt 1, Ch 3, 15 Boilers to Pt 1, Ch 3, 17 Screwshafts, tube shafts and propellers*.

3.5.26 Where any inert gas system is fitted for the protection of cargo tanks on board a ship intended for the carriage of oil or liquid chemicals in bulk, the system is to be surveyed annually in accordance with the requirements of *Pt 1, Ch 3, 2.2 Annual Surveys 2.2.32*. In addition, on ships to which an **IGS** notation has been assigned, a Special Survey of the inert gas plant is to be carried out at intervals not exceeding five years, in accordance with the requirements of *Pt 1, Ch 3, 18 Inert gas systems*.

3.5.27 Where the ship is fitted with a dynamic positioning system, the system is to be examined and tested annually in accordance with the requirements of *Pt 1, Ch 3, 2.2 Annual Surveys 2.2.23*. In addition, a Special Survey is to be carried out at intervals not exceeding five years in accordance with *Pt 1, Ch 3, 11.2 Complete Surveys 11.2.10*.

3.5.28 Where the ship is fitted with a classed refrigerated cargo installation, the installation is to be surveyed annually in accordance with the requirements of *Pt 1, Ch 3, 20.1 Annual Surveys*. In addition, a Special Survey is to be carried out at intervals not exceeding five years in accordance with the requirements of *Pt 1, Ch 3, 20.2 Special Surveys*. At the request of the Owner, consideration will be given to the Survey of the installation being carried out on the Continuous Survey basis.

3.5.29 Where the ship is fitted with a classed refrigerated cargo installation, a Loading Port Survey, as detailed in *Pt 1, Ch 3, 20.4 Loading Port Surveys*, may be carried out at the request of the Owner. On completion, a certificate will be issued recording, in addition to other details, the temperatures in the various refrigerated spaces at the time of the survey. The certificate issued by LR is not in respect of the cargo to be loaded or the manner in which it is to be stowed. A Loading Port Survey is not mandatory for classification, but may be carried out concurrently with the Annual, Continuous or Special Surveys if so desired.

3.5.30 At the request of an Owner, the Classification Committee may give special consideration to the application of the periodical survey requirements given in *Pt 1, Ch 3 Periodical Survey Regulations* to military ships or commercial ships owned or chartered by Governments, which are utilised in support of military operation or service.

3.5.31 Where the ship has been assigned an **OPS** notation, the on-shore power supply arrangements are to be examined annually in accordance with the requirements of *Pt 1, Ch 3, 2.2 Annual Surveys 2.2.26*. In addition, a Special Survey is to be carried out at intervals not exceeding five years in accordance with *Pt 1, Ch 3, 14.2 Complete Surveys 14.2.13*.

3.5.32 Where the Committee has agreed to an Owner's request to assign the notation 'laid-up', the ship may be retained in class provided a satisfactory general examination of the hull and machinery is carried out at the Annual Survey due date and an Underwater Examination (UWE) is carried out at the Special Survey due date. The general examination may be carried out within three months before or after the Annual Survey due date.

3.6 Surveys for novel/complex systems, machinery and equipment

3.6.1 Where novel/complex systems, machinery and equipment have been accepted by LR and for which existing survey requirements are not considered to be suitable and sufficient then appropriate survey requirements are to be derived as part of the design approval process. In deriving these requirements LR will consider, but not be limited to, the following:

- (a) Plan appraisal submissions;
- (b) Risk Assessment documentation where required by the Rules;
- (c) Equipment manufacturer recommendations;
- (d) Relevant recognised national or international standards.

3.7 Certificates

3.7.1 When the required reports, on completion of the survey of new or existing ships which have been submitted for classification, have been received from the Surveyors and classification has been agreed by the Classification Executive a Certificate of Classification may be issued by an authorised surveyor. After approval by the Classification Committee, a certificate of First Entry of Classification, signed by LR's Chairman or the Chairman of the Classification Committee, will be issued to Builders or Owners.

3.7.2 A Certificate of Class valid for five years subject to endorsement for Annual and Intermediate Surveys will also be issued to the Owners.

3.7.3 LR's Surveyors are permitted to issue provisional (interim) certificates to enable a ship classed with LR to proceed on her voyage (or to continue her service in the case of a fixed or tethered ship) provided that in their opinion it is in a fit and efficient condition. Such certificates will embody the Surveyors' recommendations for continuance of class, but in all cases are subject to confirmation by the Classification Committee.

3.7.4 The full class notation and abbreviated descriptive notes shall be stated on the Certificate of Class and the provisional (interim) certificate.

3.8 Notice of surveys

3.8.1 It is the responsibility of the Owners to ensure that all surveys necessary for the maintenance of class are carried out at the proper time and in accordance with the instructions of the Classification Committee. Information is available to Owners on the Class Direct website.

3.8.2 LR will make available to an Owner timely notice about forthcoming surveys by means of Quarterly Listing of Surveys, Conditions of Class and Memoranda. The omission of such notice, however, does not absolve the Owner from his responsibility to comply with LR's survey requirements for maintenance of class, all of which are available to Owners on the Class Direct website.

3.9 Withdrawal/Suspension of class

3.9.1 When the class of a ship, for which the Regulations as regards surveys on hull, equipment and machinery have been complied with, is withdrawn by the Classification Committee in consequence of a request from the Owner the notation 'Class withdrawn at Owner's request' (with date) will be assigned.

3.9.2 When the Regulations as regards surveys on hull, equipment or machinery have not been complied with and the ship is thereby not entitled to retain class, the class will be suspended or withdrawn, at the discretion of the Classification Committee, and a corresponding notation will be assigned.

3.9.3 Class will be automatically suspended and the Certificate of Class will become invalid if the Annual or Intermediate Survey is not completed within three months of the due date of the survey.

3.9.4 Class will be automatically suspended from the expiry date of the Certificate of Class in the event that the Special Survey has not been completed by the due date and an extension has not been agreed (see *Pt 1, Ch 2, 3.5 Existing ships – Periodical Surveys 3.5.9*), or is not under attendance by the Surveyors with a view to completion prior to resuming trading.

Classification will be reinstated from suspension of class upon satisfactory completion of the surveys due. The surveys to be carried out are to be based upon the survey requirements at the original date due and not on the age of the ship when the survey is carried out. Such surveys are to be credited from the date originally due. However, the ship's Class remains suspended from the date of suspension until the date Class is reinstated.

3.9.5 When, in accordance with *Pt 1, Ch 2, 3.4 Damages, repairs and alterations 3.4.4* of the Regulations, a condition of class is imposed, this will be assigned a due date for completion and the ship's class may be suspended if the condition of class is not dealt with, or postponed by agreement, by the due date.

3.9.6 When it is found, from the reported condition of the hull equipment machinery or arrangements of a ship, that an Owner has failed to comply with *Pt 1, Ch 2, 1.1 General 1.1.5, Pt 1, Ch 2, 1.1 General 1.1.9, Pt 1, Ch 2, 3.4 Damages, repairs and alterations 3.4.1* or *Pt 1, Ch 2, 3.4 Damages, repairs and alterations 3.4.6*, the class will be suspended or withdrawn, at the discretion of the Classification Committee, and a corresponding notation assigned. When it is considered that an Owner's failure to comply with these requirements is sufficiently serious, the suspension or withdrawal of class may be extended to include other ships controlled by the same Owner, at the discretion of the Classification Committee.

3.9.7 When the Classification Committee is satisfied that a ship proceeded to sea with less freeboard than that approved by the Classification Committee, or that the freeboard marks are placed higher on the sides of the ship than the position assigned or approved by the Classification Committee, or, in cases of ships where freeboards are not assigned, the draught is greater than that approved by the Classification Committee, the ship's class will be withdrawn or suspended in relation to the above voyage(s) concerned.

3.9.8 When the Classification Committee is satisfied that a specialised ship has been operated in a manner contrary to that agreed at the time of classification, or is being operated in environmental conditions which are more onerous or in areas other than those agreed by the Classification Committee, the ship's class will be withdrawn or suspended in relation to those operations.

3.9.9 Where a ship has been

- detained following a Flag State or Port State Control inspection on one or more occasions with serious deficiencies found, or
- been subject to an unscheduled survey (see *Pt 1, Ch 2, 3.3 Existing ships 3.3.5*) with serious deficiencies found,

then class will be liable to be suspended or withdrawn, at the discretion of the Classification Committee, and a corresponding notation will be assigned. In these cases, a period of notice, but not exceeding 3 months, may be given prior to any suspension or withdrawal of class.

3.9.10 When a client fails to pay all undisputed portions of invoices for the services by the contractual due date then class will be liable to be suspended or withdrawn at the discretion of the Classification Committee and a corresponding notation will be assigned. In these cases, a period of notice not exceeding 3 months may be given, prior to any suspension or withdrawal of class.

3.9.11 In all instances of class withdrawal or suspension, the assigned notation, with date of application, will be published by members of the LR Group. In cases where class has been suspended by the Classification Committee and it becomes apparent that the Owners are no longer interested in retaining LR's class it will be withdrawn.

3.9.12 When a ship is intended for a demolition voyage with any Periodical Survey overdue, the ship's class suspension may be held in abeyance and consideration may be given to allow the ship to proceed on a single direct ballast voyage from the lay up or final discharge port to the demolition yard, provided the attending Surveyor finds the ship in a satisfactory condition to proceed for the intended voyage, at the discretion of the Classification Committee.

3.9.13 When a ship is intended for a single voyage from 'laid-up' position to repair yard with any Periodical Survey overdue, the ship's class suspension may be held in abeyance and consideration may be given to allow the ship to proceed on a single direct ballast voyage from the site of lay up to the repair yard, upon agreement with the Flag Administration, at the discretion of the Classification Committee. This is provided the ship is found in a satisfactory condition by surveys, the extent of which are to be based on surveys overdue and duration of lay-up.

3.9.14 For reclassification and reinstatement of class, see *Pt 1, Ch 2, 3.3 Existing ships 3.3.2* and *Pt 1, Ch 2, 3.9 Withdrawal/Suspension of class 3.9.4*.

3.10 Appeal from Surveyors' recommendations

3.10.1 If the recommendations of the Surveyors are considered in any case to be unnecessary or unreasonable, an appeal may be made to the Classification Committee, who may direct a Special Examination to be held.

3.11 Force majeure

3.11.1 If due to circumstances reasonably beyond the Owner's or LR's control, as defined below, the ship is not in a port when surveys become overdue the Classification Committee may allow the ship to sail, in class, directly to an agreed discharge port and then, if necessary, in ballast to an agreed repair facility at which the survey can be completed. In this context, 'Force Majeure' means damage to the ship, unforeseen inability of Surveyors to attend the ship due to governmental restrictions on right of access or movement of personnel, unforeseen delays in port or inability to discharge cargo due to unusually lengthy periods of severe weather, strikes, civil strife, acts of war or other force majeure.

3.12 Ownership details

3.12.1 It is the responsibility of the Owner to inform a member of the LR Group in writing of any change to its contact details and in the event of a ship sale to supply details of the new Owners. If the new Owner of a ship cannot be properly identified and the contact details established then the class of that ship will be specially considered by the Classification Committee. It is the responsibility of the new Owner to inform a member of the LR Group in writing of their contact details and that they are now responsible for the ship, if they fail to do so then the class of that ship will be specifically considered by the Classification Committee.

■ *Section 4* **IACS and EMSA Audits and Assessments**

4.1 Audit of surveys

4.1.1 The surveys required by the Regulations may be subject to audit or assessment in accordance with the requirements of the International Association of Classification Societies and European Maritime Safety Agency requirements.

■ *Section 5* **Type Approval/Type Testing/Quality Control System**

5.1 LR Type Approval – Marine Applications

5.1.1 LR Type Approval is an impartial certification system that provides independent third-party Type Approval Certificates attesting to a product's conformity with specific standards or specifications. It is based on design review and type testing or where testing is not appropriate, a design analysis.

5.1.2 The LR Type Approval System is a process whereby a product is assessed in accordance with a specification, standard or code to check that it meets the stated requirements and through selective testing demonstrates compliance with specific performance requirements. The testing is carried out on a prototype or randomly selected product(s) which are representative of the manufactured product under approval. Thereafter, the producer is required to use Quality Control procedures and processes to ensure that each item delivered is in conformity with that which has been Type Approved.

5.1.3 The selective testing required by *Pt 1, Ch 2, 5.1 LR Type Approval – Marine Applications 5.1.2* is to include environmental testing applicable to the product's installation on board a ship classed or intended to be classed with LR.

5.1.4 LR Type Approval does not remove the requirements for inspection and survey procedures required by the Rules for equipment to be installed in ships classed or intended to be classed with LR. Also, LR Type Approval does not remove the requirement for plan appraisal of a system that incorporates Type Approved equipment where required by the Rules.

5.1.5 LR Type Approval is subject to the understanding that the producer's recommendations and instructions for the product and any relevant requirements of the Rules for the Classification of Ships are fulfilled.

5.1.6 The producer supplying equipment or components under Quality Control procedures and processes is to have a recognized quality management system certified by an IACS member or Notified Body. The Quality Control procedures and processes are to address the production of the product consistent with *Pt 1, Ch 2, 5.3 Quality Control System*.

5.1.7 Where equipment or components have been Type Approved in accordance with specifications and procedures other than LR's, details of the product, certification and testing are to be submitted for consideration where appropriate.

5.2 Type testing

5.2.1 Type testing is an impartial process that provides independent third-party verification that an item of machinery or equipment has satisfactorily undergone a functional type test.

5.2.2 Type testing is carried out against defined performance and test standards for a defined period of time with test conditions varying between minimum and maximum declared design conditions.

5.2.3 Type testing is carried out on a prototype or randomly selected product(s) which are representative of the manufactured product under assessment.

5.2.4 After type testing, mechanical equipment is to be opened out and inspected for damage or excessive wear.

5.2.5 On application from the manufacturer, type tests may be waived for equipment and machinery that has been proven to be reliable in marine service and where compliance with the current applicable standards can be demonstrated. Equipment and machinery that has been previously type tested with satisfactory testing evidence and certification need not have the type tests repeated where previous testing is in accordance with current testing standards.

5.2.6 The acceptance of type testing certification is subject to the understanding that the manufacturer's recommendations and instructions for the product and any relevant requirements of the applicable Rules are fulfilled.

5.3 Quality Control System

5.3.1 A quality control system for the purposes of LR acceptance of materials and machinery refers to a scheme that covers the operational techniques and activities that is used to demonstrate that the quality requirements for a product are in accordance with declared standards.

5.3.2 The quality control system for a particular product extends to all parties involved in the supply chain from manufacture and testing through to delivery of the product.

5.3.3 LR acceptance of machinery and equipment manufactured under a quality control scheme is dependent on the scheme being maintained through a traceable process involving planned audits and spot inspections at the discretion of LR Surveyors. The purpose of the audits and spot inspections is to ensure that the procedures for manufacture and quality control are being maintained in a satisfactory manner.

5.3.4 The use of a quality control system does not remove the requirements for inspection processes that may be required by the Rules applicable to the equipment being supplied with a manufacturer's certificate. Also the use of a quality control system does not remove the requirement for plan appraisal of equipment or systems where required by the Rules.

■ *Section 6***Classification of machinery with [✕] LMC or MCH notation****6.1 General**

6.1.1 After delivery of machinery and equipment with the manufacturer's certificate to the shipyard, Survey at the Shipyard and Periodical Surveys are to be in accordance with the requirements for ships built or accepted into class with the ✕ **LMC** notation.

6.2 Appraisal and records

6.2.1 To facilitate survey and compilation of classification records, plans and information required for a ship being accepted into class with the ✕ **LMC** notation are to be submitted for appraisal and information. Plans are not required where machinery and equipment has previously been type approved; in these cases it is only necessary to submit details of the machinery and equipment together with details of previous approval.

6.3 Survey and inspection

6.3.1 The manufacturer's certificate for acceptance of machinery and equipment for assignment of the [✕] **LMC** or **MCH** notation is to be in the English language and include the following information:

- (a) Design and manufacturing standard(s) used.
- (b) Materials used for construction of key components and their sources.
- (c) Details of the quality control system applied during design, manufacture and testing and of any software maintenance.
- (d) Details of any type approval or type testing.
- (e) Details of installation and testing recommendations for the machinery or equipment.

The manufacturer is to have a recognized quality management system certified by an IACS member or a Notified Body.

6.3.2 The installation and testing of machinery and equipment at the build yard which has been supplied with a manufacturer's certificate is to be in accordance with the requirements applicable to a ship having the ✕ **LMC** notation.

Section

- 1 **General**
- 2 **Annual Surveys - Hull and machinery requirements**
- 3 **Intermediate Surveys - Hull and machinery requirements**
- 4 **Docking Surveys and In-water Surveys - Hull and machinery requirements**
- 5 **Special Survey - General - Hull requirements**
- 6 **Special Survey - Bulk carriers - Hull requirements**
- 7 **Special Survey - Oil tankers (including ore/oil ships and ore/bulk/oil ships) - Hull requirements**
- 8 **Special Survey - Chemical Tankers - Hull requirements**
- 9 **Ships for liquefied gases**
- 10 **Dredgers, hopper dredgers, sand carriers, hopper barges and reclamation craft**
- 11 **Machinery surveys - General requirements**
- 12 **Turbines and steam engines - Detailed requirements**
- 13 **Reciprocating internal combustion engines - Detailed requirements**
- 14 **Electrical equipment**
- 15 **Boilers**
- 16 **Steam pipes**
- 17 **Screwshafts, tube shafts and propellers**
- 18 **Inert gas systems**
- 19 **Classification of ships not built under survey**
- 20 **Refrigerated cargo installations**
- 21 **Controlled atmosphere systems**
- 22 **Bow, inner, side shell and stern doors on Ro-Ro ships**
- 23 **Natural gas fuel Installations**

■ Section 1 General

1.1 Frequency of surveys

1.1.1 The requirements of this Chapter are applicable to the Periodical Surveys set out in *Pt 1, Ch 2, 3.5 Existing ships – Periodical Surveys*. Except as amended at the discretion of the Committee, the periods between such surveys are as follows:

- (a) Annual Surveys, as required by *Pt 1, Ch 2, 3.5 Existing ships – Periodical Surveys 3.5.1*.
- (b) Intermediate Surveys, as required by *Pt 1, Ch 2, 3.5 Existing ships – Periodical Surveys 3.5.2*.
- (c) Docking Surveys, as required by *Pt 1, Ch 2, 3.5 Existing ships – Periodical Surveys 3.5.3* and *Pt 1, Ch 2, 3.5 Existing ships – Periodical Surveys 3.5.4*.
- (d) When ships classed **100A1 shipborne barge** are subjected to Intermediate Surveys, those surveys become due 30 months after the previous Special Survey, see *Pt 1, Ch 2, 3.5 Existing ships – Periodical Surveys 3.5.7*.

(e) Special Surveys at five-yearly intervals, see *Pt 1, Ch 2, 3.5 Existing ships – Periodical Surveys 3.5.9*. For alternative arrangements, see also *Pt 1, Ch 2, 3.5 Existing ships – Periodical Surveys 3.5.10*, *Pt 1, Ch 2, 3.5 Existing ships – Periodical Surveys 3.5.11*, *Pt 1, Ch 2, 3.5 Existing ships – Periodical Surveys 3.5.12* and *Pt 1, Ch 2, 3.5 Existing ships – Periodical Surveys 3.5.14*.

(f) Complete Surveys of machinery at five-yearly intervals, see *Pt 1, Ch 2, 3.5 Existing ships – Periodical Surveys 3.5.18*.

1.1.2 For ships assigned the notation 'laid-up', in order to maintain the ship in class a general examination of the hull and machinery is to be carried out in lieu of the Annual Survey and an Underwater Examination (UWE) is to be carried out in lieu of the Special Survey, see *Pt 1, Ch 3, 2.1 General 2.1.5*, *Pt 1, Ch 3, 5.1 General 5.1.6* and *Pt 1, Ch 3, 11.1 Annual, Intermediate and Docking Surveys 11.1.2*.

1.1.3 When it has been agreed that the complete survey of the hull and machinery may be carried out on the Continuous Survey basis, all compartments of the hull and all items of machinery are to be opened for survey in rotation to ensure that the interval between consecutive examinations of each part will not exceed five years, see *Pt 1, Ch 2, 3.5 Existing ships – Periodical Surveys 3.5.14* and *Pt 1, Ch 2, 3.5 Existing ships – Periodical Surveys 3.5.21*.

1.1.4 For the frequency of surveys of boilers, steam pipes, screwshafts, tube shafts, propellers and inert gas systems, see *Pt 1, Ch 3, 15 Boilers* to *Pt 1, Ch 3, 18 Inert gas systems*.

1.1.5 For the requirements for surveys of refrigerated cargo installations, see *Pt 6, Ch 3 Refrigerated Cargo Installations*.

1.1.6 In general, the periodical survey requirements contained in *Pt 1, Ch 3 Periodical Survey Regulations* also apply to ships built in accordance with the *IACS Common Structural Rules for Bulk Carriers and Oil Tankers (CSR)*. Where a requirement does not apply to CSR ships, or where a specific requirement applies only to CSR ships, this will be clearly stated.

1.2 Surveys for damage or alterations

1.2.1 At any time when a ship is undergoing alterations or damage repairs, any exposed parts of the structure normally difficult to access are to be specially examined, e.g. if any part of the main or auxiliary machinery, including boilers, insulation or fittings, is removed for any reason, the steel structure in way is to be carefully examined by the Surveyor, or when cement in the bottom or covering on decks is removed, the plating in way is to be examined before the cement or covering is relaid.

1.3 Unscheduled surveys

1.3.1 In the event that Lloyd's Register (hereinafter referred to as LR) has cause to believe that its Rules and Regulations are not being complied with, LR reserves the right to perform unscheduled surveys of the hull and machinery as well as the applicable statutory requirements whether or not the appropriate statutory certificate has been issued by LR.

1.3.2 In the event of significant damage or defect affecting any ship, LR reserves the right to perform unscheduled surveys of the hull or machinery of other similar ships classed by LR and deemed to be vulnerable.

1.4 Surveys for the issue of Convention certificates

1.4.1 Surveys are to be held by LR when so appointed, or by the Exclusive Surveyors to a National Administration or by an IACS Member when so authorised by the National Authority, or, in the case of Cargo Ship Safety Radio Certificates or Safety Management Certificates, by any organisation authorised by the National Authority. In the case of dual classed ships, Convention Certificates may be issued by the other Society with which the ship is classed provided this is recognised in a formal Dual Class Agreement with LR and provided the other Society is also authorised by the National Authority.

1.5 Definitions

1.5.1 An **Oil Tanker** is a sea going self-propelled ship which is constructed generally with integral tanks and is intended primarily to carry oil in bulk and includes ship types such as combination carriers (ore/oil and ore/bulk/oil ships, etc.). Where referred to in this Chapter, it shall also include double hull oil tankers as well as tankers with alternative structural arrangements, e.g. mid-deck designs, except where specified. Single hull oil tankers and combination carriers are not covered by the IACS Common Structural Rules (CSR).

1.5.2 A **Double Hull Oil Tanker** is a sea going self-propelled ship which is constructed primarily for the carriage of oil in bulk, where the cargo tanks are protected by a double hull extending for the entire length of the cargo area, consisting of double side and double bottom spaces for the carriage of salt-water ballast.

1.5.3 A **Bulk Carrier** is a sea going self-propelled ship which is constructed generally with single deck, double bottom, topside tanks and hopper side tanks and with single side skin construction in the cargo length area, and is intended primarily to

carry dry cargo in bulk and includes ship types such as ore carriers. Where referred to in this Chapter, it shall also include double skin bulk carriers except where specified.

1.5.4 A **Double Skin Bulk Carrier** is a sea going self-propelled ship which is constructed generally with single deck, double bottom, topside tanks and hopper side tanks and with double side skin construction in the cargo length area (regardless of the width of the wing space) and is intended primarily to carry dry cargo in bulk and includes such types as ore carriers.

1.5.5 An **Ore Carrier** is a sea going self-propelled ship which is constructed generally with single deck, two longitudinal bulkheads and a double bottom throughout the cargo length area and intended primarily to carry ore cargoes in the centre holds only. Ore carriers are not covered by the IACS Common Structural Rules (CSR).

1.5.6 A **Chemical Tanker** is a sea going self-propelled ship constructed generally with integral tanks and being single or double hull construction, or having alternative structural arrangements, used primarily for the carriage in bulk of any liquid product listed in *Chapter 17 Summary of minimum requirements of the IBC Code - International Code for the Construction and Equipment of Ships Carrying Dangerous Chemicals in Bulk* Amended by Resolution MEPC.225(64) .

1.5.7 A **Gas Carrier** is a cargo ship constructed or adapted and used for the carriage in bulk of any liquefied gas or other products of flammable nature listed in *Chapter 19 of the International Code for the Construction and Equipment of Ships Carrying Liquefied Gases in Bulk*.

1.5.8 A **Ballast Tank** is a tank which is used solely for the carriage of salt-water ballast. For bulk carriers, a space which is used for both cargo and salt-water ballast will be treated as a salt-water ballast tank when substantial corrosion has been found in that space. For double skin bulk carriers, the double side tank is to be considered as a separate tank even if it is connected to either the topside or hopper side tank. For oil tankers and chemical tankers, a combined tank which is used for both cargo and salt-water ballast as a routine part of the ship's operation will be treated as a ballast tank. A cargo tank which in exceptional cases may carry salt-water ballast during severe weather conditions and is not designated as a combined cargo/ballast tank will be treated as a cargo tank.

1.5.9 **Spaces** are separate compartments such as holds, tanks, cofferdams and void spaces bounding cargo holds, decks and the outer hull.

1.5.10 **Enclosed space.** An enclosed space is any place of an enclosed nature where there is a risk of death or serious injury from hazardous substances or dangerous conditions. Examples include, but are not limited to: boilers, pressure vessels, cargo spaces (cargo holds or cargo tanks), cargo space stairways, ballast tanks, double bottoms, double hull spaces, fuel oil tanks, lube oil tanks, sewage-tanks, pump-rooms, compressor rooms, cofferdams, void spaces, duct keels, inter-barrier spaces, engine crankcases, excavations and pits.

1.5.11 An **Overall Survey** is a survey intended to report on the overall condition of the hull structure and to determine the extent of additional Close-up Surveys.

1.5.12 A **Close-up Survey** is a survey where the details of structural components are within the close visual inspection range of the Surveyor, i.e. normally within reach of hand.

1.5.13 A **Transverse Section** includes all longitudinal members such as plating, longitudinals and girders at the deck, side, bottom, inner bottom, inner side, hopper side, top wing side and longitudinal bulkhead, where fitted. For transversely framed ships, a transverse section includes adjacent frames and their end connections in way of transverse sections.

1.5.14 **Representative Spaces** are those which are expected to reflect the condition of other spaces of similar type and service and with similar corrosion prevention systems. When selecting representative spaces, account is to be taken of the service and repair history on board and identifiable Critical Structural Areas.

1.5.15 **Critical Structural Areas** are locations which have been identified from calculations to require monitoring or from the service history of the subject ship or from similar ships or sister ships, if applicable, to be sensitive to cracking, buckling or corrosion which would impair the structural integrity of the ship.

1.5.16 **Substantial Corrosion** is wastage of individual plates and stiffeners in excess of 75 per cent of allowable margins, but within acceptable limits. For ships built in accordance with the IACS Common Structural Rules (CSR), substantial corrosion is an extent of corrosion such that the assessment of the corrosion pattern indicates a gauged (or measured) thickness between $t_{ren} + 0,5 \text{ mm}$ and t_{ren} . Renewal thickness, t_{ren} , is the minimum allowable thickness, in mm, below which renewal of the structural members is to be carried out.

1.5.17 Steel renewal requirements have been separately determined according to date of contract for construction for:

(a) cargo hold hatch covers and coamings under IACS UR S21 and UR S21A; and

(b) bulk carriers' corrugated transverse watertight cargo hold bulkheads under IACS UR S18. See *Pt 1, Ch 3, 5.6 Thickness measurement, Pt 1, Ch 3, 6.7 Thickness measurement and Pt 1, Ch 3, 7.7 Thickness measurement*.

In these cases, the net thickness, t_{net} , is the minimum net thickness of the structural member, excluding any corrosion addition, and is defined in *Pt 4, Ch 7, 12.1 General 12.1.2 for Hatch Covers and Pt 4, Ch 7, 10.4 Vertically corrugated transverse watertight bulkheads – Application and definitions 10.4.10 for Transverse Bulkheads*.

1.5.18 **A Corrosion Prevention System** is normally considered a full hard protective coating. This is usually to be an epoxy coating or equivalent. Other systems with the exception of soft and semi-hard coatings, may be considered acceptable as alternatives provided they are applied and properly maintained in compliance with the manufacturer's specification.

1.5.19 For the application of requirements outlined in Sections *Pt 1, Ch 3, 2 Annual Surveys - Hull and machinery requirements, Pt 1, Ch 3, 3 Intermediate Surveys - Hull and machinery requirements, Pt 1, Ch 3, 4 Docking Surveys and In-water Surveys - Hull and machinery requirements and Pt 1, Ch 3, 5 Special Survey - General - Hull requirements*, a general dry cargo ship is a self-propelled ship of 500 gross tonnes or above, constructed generally with a 'tween deck and intended to carry solid cargoes, other than:

- bulk carriers;
- ships dedicated to the carriage of containers;
- roll on-roll off ships;
- refrigerated cargo ships;
- dedicated wood chip carriers;
- dedicated cement carriers;
- livestock carriers;
- dock/deck cargo ships;
- general dry cargo ships of double side-skin construction, with double side-skin extending for the entire length of the cargo area, and for the entire height of the cargo hold to the upper deck.

1.5.20 **Coating Condition** is defined as follows:

- GOOD:** Condition with only minor spot rusting.
- FAIR:** Condition with local breakdown of coating at edges of stiffeners and weld connections and/or light rusting over 20 per cent or more of areas under consideration, but less than as defined for POOR condition.
- POOR:** Condition with general breakdown of coating over 20 per cent or more of areas or hard scale at 10 per cent or more of areas under consideration.

These are further clarified as follows, in order to achieve a unified assessment of coating conditions, see *Table 3.1.1 Assessment of coating conditions*:

- GOOD:** Condition with spot rusting on less than 3 per cent of the area under consideration without visible failure of the coating. Rusting at edges or welds should be on less than 20 per cent of edges or weld lines in the area under consideration.
- FAIR:** Condition with breakdown of coating or rust penetration on less than 20 per cent of the area under consideration. Hard rust scale should be less than 10 per cent of the area under consideration. Rusting at edges or welds should be on less than 50 per cent of edges or weld lines in the area under consideration.
- POOR:** Condition with breakdown of coating or rust penetration on more than 20 per cent or hard rust scale on more than 10 per cent of the area under consideration or local breakdown concentrated at edges or welds on more than 50 per cent of edges or weld lines in the area under consideration.

Further information on coating assessment can be found in the LR document *Thickness Measurement and Close-Up Survey Guidance*.

Table 3.1.1 Assessment of coating conditions

	GOOD ⁽³⁾	FAIR	POOR
Breakdown of coating or area rusted ⁽¹⁾	< 3%	3–20%	> 20%
Area of hard rust scale ⁽¹⁾	—	10%	≥ 10%

Local breakdown of coating or rust on edges or weld lines ⁽²⁾	< 20%	20–50%	> 50%
Note 1. % is the percentage calculated on basis of the area under consideration or of the 'critical structural area'.			
Note 2. % is the percentage calculated on basis of edges or weld lines in the area under consideration or of the 'critical structural area'.			
Note 3. Spot rusting, i.e. rusting in spot without visible failure of coating.			

1.5.21 **Pitting Corrosion.** Pitting corrosion is defined as scattered corrosion spots/areas with local material reductions which are greater than the general corrosion in the surrounding area. Further information on pitting intensity can be found in the LR document *Thickness Measurement and Close-Up Survey Guidance*.

1.5.22 **Edge Corrosion.** Edge corrosion is defined as local corrosion at the free edges of plates, stiffeners, primary support members and around openings. An example of edge corrosion can be found in the LR document *Thickness Measurement and Close-Up Survey Guidance*.

1.5.23 **Grooving Corrosion.** Grooving corrosion is typically local material loss adjacent to weld joints along abutting stiffeners and at stiffener or plate butts or seams. An example of groove corrosion can be found in the LR document *Thickness Measurement and Close-Up Survey Guidance*.

1.5.24 A **Prompt and Thorough Repair** is a permanent repair completed at the time of survey to the satisfaction of the Surveyor, therein removing the need for the imposition of any associated condition of class or recommendation.

1.5.25 Bulk carriers with hybrid cargo hold arrangements are to have single skin cargo holds surveyed in accordance with the requirements for single skin bulk carriers and the double skin cargo holds surveyed in accordance with the requirements for double skin bulk carriers.

1.5.26 **Special consideration** or **specially considered** (in connection with close-up surveys and thickness measurements) means sufficient close-up inspection and thickness measurements are to be taken to confirm the actual average condition of the structure under the coating.

1.5.27 **Air pipe heads** installed on the exposed decks are those extending above the freeboard deck or superstructure decks.

1.5.28 The **Cargo Area** or **Cargo Length Area** is that part of the ship which contains all cargo holds and adjacent areas including fuel tanks, cofferdams, ballast tanks and void spaces. For oil tankers and chemical tankers, the **Cargo Area** is that part of the ship which contains cargo tanks, slop tanks and cargo/ballast pump-rooms, cofferdams, ballast tanks and void spaces adjacent to cargo tanks and also deck areas throughout the entire length and breadth of the part of the ship over the above mentioned spaces.

1.5.29 A **Natural gas fuel installation** comprises the following; fuel bunkering, fuel storage, fuel processing and fuel delivery to gas fuelled consumers. The scope of the natural gas fuel installation extends from the bunker manifold to the natural gas fuelled consumer and includes any re-liquefaction plant and compressors that are fitted to manage boil off. These installations may be on board any ship type referred to in this Chapter except gas carriers as defined in *Pt 1, Ch 3, 1.5 Definitions 1.5.7*.

1.6 Preparation for survey and means of access

1.6.1 In order to enable the attending Surveyor(s) to carry out surveys, provisions for safe access and for surveys are to be agreed between the Owner and LR. Attention is drawn to the applicable recommendations in the IACS PR37 and/or IMO Recommendations For Entering Enclosed Spaces Aboard Ships, Resolution A.1050(27).

1.6.2 Means are to be provided to enable the Surveyor to examine the structure in a safe and practical way. Where the provisions of safety and required access are determined by the Surveyor not to be adequate, then the survey of the space(s) involved is not to proceed.

1.6.3 Spaces are to be made safe for access and survey and are to be sufficiently cleaned, illuminated and ventilated.

1.6.4 In preparation for survey, thickness measurements and to allow for a thorough examination, cleaning is to include removal from surfaces of all loose accumulated corrosion scale. Spaces are to be sufficiently clean and free from water, scale, dirt, and oil residues, etc. to reveal corrosion, deformation, fractures, damages or other structural deterioration, as well as the condition of the protective coating. However, those areas of structure whose renewal has already been decided by the Owner need only be cleaned and descaled to the extent necessary to determine the limits of renewed areas.

1.6.5 Where soft or semi-hard coatings have been applied, safe access is to be provided for the Surveyor to verify the effectiveness of the coating and to carry out an assessment of the conditions of internal structures which may include spot removal of the coating. When safe access cannot be provided, the soft or semi-hard coating is to be removed.

1.6.6 Prior to entering an enclosed space, it is to be verified by a competent person using a calibrated multi gas meter that the atmosphere in that space is free from hazardous gas and contains sufficient oxygen.

1.6.7 Emergency equipment and personnel are to be available in case of an emergency or rescue operation.

1.6.8 Information on procedures, equipment-operating instructions and safety checklists is to be available.

1.6.9 During the survey, ventilation is to be ensured and periodic testing is to be carried out as necessary to verify that the atmosphere remains safe for access.

1.6.10 For surveys, including close-up survey where applicable, in cargo spaces and ballast tanks, one or more of the following means of access is to be provided:

- (a) Permanent staging and passages through structures.
- (b) Temporary staging and passages through structures.
- (c) Hydraulic arm vehicles such as conventional cherry pickers, lifts and movable platforms.
- (d) Portable ladders, see Note.
- (e) Boats or rafts.
- (f) Other equivalent means.

Note Portable ladders may be used, at the discretion of the Surveyor, for survey of the hull structure of single skin bulk carriers, except for the close-up survey of cargo hold shell frames, see *Pt 1, Ch 3, 1.6 Preparation for survey and means of access 1.6.11* and *Pt 1, Ch 3, 1.6 Preparation for survey and means of access 1.6.12*

1.6.11 For close-up surveys of the cargo hold shell frames of single skin bulk carriers with a deadweight less than 100,000 tonnes, one or more of the following means of access is to be provided:

- (a) Permanent staging and passages through structures.
- (b) Temporary staging and passages through structures.
- (c) Portable ladder restricted to not more than 5 m in length may be accepted for surveys of the lower section of a shell frame including bracket.
- (d) Hydraulic arm vehicles such as conventional cherry pickers, lifts and movable platforms.
- (e) Boats or rafts, provided the structural capacity of the hold is sufficient to withstand static loads at all levels of water.
- (f) Other equivalent means.

1.6.12 For close-up surveys of the cargo hold shell frames of single skin bulk carriers with a deadweight equal to or greater than 100,000 tonnes, the use of portable ladders is not accepted and one or more of the following means of access is to be provided:

- (a) At Annual Surveys, Intermediate Surveys held before the ship is 10 years old and Special Survey I:
 - (i) Permanent staging and passages through structures.
 - (ii) Temporary staging and passages through structures.
 - (iii) Hydraulic arm vehicles such as conventional cherry pickers, lifts and movable platforms.
 - (iv) Boats or rafts, provided the structural capacity of the hold is sufficient to withstand static loads at all levels of water.
 - (v) Other equivalent means.
- (b) At Special Survey II and all subsequent Intermediate Surveys and Special surveys:
 - (i) Either permanent or temporary staging and passage through structures for close-up survey of at least the upper part of hold frames.
 - (ii) Hydraulic arm vehicles such as conventional cherry pickers for surveys of lower and middle part of shell frames as alternative to staging.
 - (iii) Lifts and movable platforms.
 - (iv) Boats or rafts, provided the structural capacity of the hold is sufficient to withstand static loads at all levels of water.
 - (v) Other equivalent means.
- (c) Notwithstanding the above requirements, for single skin bulk carriers greater than 10 years old, at Annual Survey the use of a portable ladder fitted with a mechanical device to secure the upper end of the ladder is acceptable for when the close-up survey of cargo hold shell frames is required.

1.6.13 Survey at sea or anchorage may be undertaken when the Surveyor is fully satisfied with the necessary assistance from the personnel onboard and provided the foregoing preparations for survey, as applicable, have been met. In addition, the following conditions and limitations are to be applied:

- (a) A communication system is to be arranged between the survey party in the tank and the responsible officer on deck. This system must include the personnel in charge of ballast pump handling if boats or rafts are to be used.
- (b) Surveys of tanks by means of boats or rafts are to be agreed with the attending Surveyor, who is to take into account the safety arrangements provided, including weather forecasting and ship response under foreseeable sea conditions and provide the expected rise of water within the tank does not exceed 0,25 m.

Where it has been agreed to use boats or rafts when carrying out close-up survey, the following conditions are to be observed:

- (i) Only rough duty, inflatable rafts or boats, having satisfactory residual buoyancy and stability even if one chamber is ruptured, are to be used.
 - (ii) The boat or raft is to be tethered to the access ladder and an additional person is to be stationed down the access ladder with a clear view of the boat or raft.
 - (iii) Appropriate lifejackets are to be available for all participants.
 - (iv) The surface of water in the tank is to be calm and the water level stationary. On no account is the level of the water to be rising while the boat or raft is in use.
 - (v) The tank or space must contain clean ballast water only. Even a thin sheen of oil on the water is not acceptable.
 - (vi) At no time is the water level to be allowed to be within 1 m of the deepest under deck web face flat so that the survey team is not isolated from a direct escape route to the tank hatch. Filling to levels above the deck transverses is only to be contemplated if a deck access manhole is fitted and open in the bay being examined, so that an escape route for the survey party is available at all times. Other effective means of escape to the deck may be considered.
 - (vii) If the tanks (or spaces) are connected by a common venting system, or Inert Gas system, the tank in which the boat or raft is to be used is to be isolated to prevent a transfer of gas from other tanks (or spaces).
- (c) Rafts or boats may be permitted for the survey of the under deck areas of tanks or spaces, if the depth of the under deck web plating is 1,5 m or less. If the depth of the under deck web plating is greater than 1,5 m, then rafts or boats may be permitted only when the coating of the under deck structure is in GOOD condition and there is no evidence of wastage or if a permanent means of access is provided in each bay to allow safe entry and exit. A permanent means of access is considered to mean:
- (i) Access direct from the deck via a vertical ladder and a small platform fitted approximately 2 m below the deck in each bay or,
 - (ii) Access to deck from a longitudinal permanent platform having ladders to the deck at each end of the tank. The platform shall be arranged over the full length of the tank and level with, or above, the maximum water level needed for rafting of the under deck structure. For this purpose, the ullage corresponding to the maximum water level is to be assumed not more than 3 m from the deck plate measured at the midspan of deck transverses and at the mid point of the tank's length.

If neither of the above conditions are met, then staging or another equivalent means is to be provided for the survey of the under deck areas.

1.6.14 Rescue and emergency response equipment: if breathing apparatus and/or other equipment is used as 'rescue and emergency response equipment', it is recommended that the equipment be suitable for the configuration of the space being surveyed.

1.6.15 For ships assigned the notation **ESP**, the Owner is to respond to a Survey Planning Questionnaire and to prepare a Survey Programme, see *Pt 1, Ch 3, 6.3 Planning for survey*, *Pt 1, Ch 3, 7.3 Planning for survey* and *Pt 1, Ch 3, 8.3 Planning for survey*. In such cases, the following requirements are applicable:

- (a) The Survey Planning Questionnaire is to be submitted to LR prior to the preparation of a Survey Programme. The response to the Questionnaire is to include information on access provisions for close-up Surveys and thickness measurements; cargo history; the results of inspections carried out by the Owner; a list of reports of Port State Control Inspection containing hull structural deficiencies; a list of Safety Management System non-conformities related to hull maintenance and details of the thickness measurement company.
- (b) The Survey Programme is to be submitted prior to the commencement of any part of the Intermediate Survey on ships over 10 years of age and Special Survey. This is to be in a written format and submitted to LR at least six months in advance of the survey. The Survey Programme at Intermediate Survey may consist of the Survey Programme agreed for the previous

Special Survey supplemented by the Executive Hull Summary of that Special Survey and later relevant survey reports. The survey will not commence until a Survey Programme has been agreed.

- (c) The Survey Programme is to be worked out taking into account any amendments to the survey requirements implemented after the previous Special Survey.
- (d) Further information on the Survey Planning Questionnaire and Survey Programme can be found in the *ESP guidance booklets* that have been prepared by LR and are available on the Class Direct website.
- (e) Prior to the commencement of any part of the Intermediate Survey and Special Survey, a survey planning meeting is to be held between the attending Surveyor(s), the Owner's representative in attendance, the thickness measurement company operator representative (as applicable) and the Master of the ship or an appropriately qualified representative appointed by the Master or Owner for the purpose of ascertaining that all the arrangements envisaged in the Survey Programme are in place, so as to ensure the safe and efficient conduct of the survey to be carried out. The following is an indicative list of items that are to be addressed in the meeting:
 - (i) Schedule of the ship (i.e. the voyage, docking and undocking manoeuvres, periods alongside, cargo and ballast operations, etc.).
 - (ii) Provisions and arrangements for thickness measurements (i.e. access, cleaning/de-scaling, illumination, ventilation, personal safety).
 - (iii) Extent of the thickness measurements.
 - (iv) Permissible diminution levels.
 - (v) Extent of close-up survey and thickness measurement considering the coating condition and suspect areas/areas of substantial corrosion.
 - (vi) Execution of thickness measurements.
 - (vii) Taking representative readings in general and where uneven corrosion/pitting is found.
 - (viii) Mapping of areas of substantial corrosion.
 - (ix) Communication between attending surveyor(s), the thickness measurement company operator(s) and Owner's representative(s) concerning findings.
- (f) Proper preparation and close co-operation between the attending Surveyor(s) and the Owner's representative on board prior to and during the survey are an essential part in the safe and efficient conduct of the survey. During the survey on board safety meetings are to be held regularly.

1.6.16 For **natural gas fuel installations** see also *Pt 1, Ch 3, 23.1 General*.

1.7 Thickness measurement at surveys

1.7.1 This Section is applicable to the thickness measurement of the hull structure where required by Sections *Pt 1, Ch 3, 2 Annual Surveys - Hull and machinery requirements, Pt 1, Ch 3, 3 Intermediate Surveys - Hull and machinery requirements, Pt 1, Ch 3, 5 Special Survey - General - Hull requirements, Pt 1, Ch 3, 6 Special Survey - Bulk carriers - Hull requirements, Pt 1, Ch 3, 7 Special Survey - Oil tankers (including ore/oil ships and ore/bulk/oil ships) - Hull requirements, Pt 1, Ch 3, 8 Special Survey - Chemical Tankers - Hull requirements and Pt 1, Ch 3, 9 Ships for liquefied gases*.

1.7.2 Prior to the commencement of the Intermediate Survey and Special Survey, a meeting is to be held between the attending Surveyor(s), the Owner's representative in attendance, the thickness measurement company representative and the Master of the ship or an appropriately qualified representative appointed by the Master or Owner, so as to ensure the safe and efficient conduct of the survey and thickness measurements to be carried out.

1.7.3 Thickness measurements are normally to be taken by means of ultrasonic test equipment and are to be carried out by a firm approved in accordance with LR's *Approval for Thickness Measurement of Hull Structure*. For non-**ESP** ships less than 500 gross tons and all fishing vessels, a suitably qualified exclusive Surveyor (where available) may carry out thickness measurements. On all other occasions, an approved firm is to carry out the thickness measurements.

1.7.4 The Surveyor may require to measure the thickness of the material in any portion of the structure where signs of wastage are evident or wastage is normally found. Any parts of the structure which are found defective or excessively reduced in scantlings are to be made good by materials of the approved scantlings and quality. Attention is to be given to the structure in way of discontinuities. If a corrosion control **CC** special features notation, as defined in the *Register Book*, is assigned, then surfaces are to be re-coated as necessary.

1.7.5 Thickness measurements are to be witnessed by the Surveyor. This requires the Surveyor to be on board, while the measurements are carried out, to the extent necessary to control the process. This also applies to thickness measurements carried out while the ship is at sea.

1.7.6 The Surveyor may extend the scope of thickness measurement if deemed necessary.

1.7.7 Where it is required as part of the survey to carry out thickness measurements for the structural areas subject to Close-up Survey, then these measurements are to be carried out simultaneously with the Close-up Survey.

1.7.8 Thickness measurements are to be taken in the forward and aft areas of all plates. Where plates cross ballast/cargo tank boundaries separate measurements for the area of plating in way of each type of tank are to be reported. In all cases the measurements are to represent the average of multiple measurements taken on each plate and/or stiffener. Where measured plates are renewed, the thicknesses of adjacent plates in the same strake are to be reported.

1.7.9 A report is to be prepared by the approved firm or Surveyor carrying out the thickness measurements. The report is to give the location of measurement, the thickness measured as well as the corresponding original thickness. The report is to give the date when measurement was carried out, the type of measuring equipment, names of personnel and their qualifications and is to be signed by the operator.

1.7.10 The thickness measurement report is to be verified and signed by the Surveyor and countersigned by an authorising Surveyor.

1.7.11 In all cases the extent of the thickness measurements is to be sufficient to represent the actual average condition.

1.8 Repairs

1.8.1 Any damage in association with wastage over the allowable limit (including buckling, grooving, detachment or fracture), or extensive areas of wastage over the allowable limits, which affects or, in the opinion of the Surveyor, will affect the ship's structural, watertight or weathertight integrity, is to be promptly and thoroughly repaired. Areas to be considered include, (where fitted):

- side shell frames, their end attachments and adjacent shell plating;
- deck structure and deck plating;
- bottom structure and bottom plating;
- side structure and side plating;
- inner bottom structure and inner bottom plating;
- inner side structure and inner side plating;
- watertight or oiltight bulkheads;
- hatch covers and hatch coamings;
- the weld connection between air pipes and deck plating;
- air pipe heads installed on the exposed decks;
- ventilators, including closing devices.

For locations where adequate repair facilities are not available, consideration may be given to allow the ship to proceed directly to a repair facility. This may require discharging the cargo and/or temporary repairs for the intended voyage.

1.8.2 Additionally, when a survey results in the identification of structural defects or corrosion, either of which, in the opinion of the Surveyor, will impair the ship's fitness for continued service, remedial measures are to be implemented before the ship continues in service.

1.8.3 Where the damage found on structure mentioned in *Pt 1, Ch 3, 1.8 Repairs 1.8.1* is isolated and of a localised nature which does not affect the ship's structural integrity (as, for example, a localised, isolated and very minor hole in a cross-deck strip), consideration may be given by the Surveyor to allow an appropriate temporary repair to restore watertight or weathertight integrity after careful evaluation of the surrounding structure and impose an associated Condition of Class with a specific short-term time limit in order to complete the repair and retain classification.

■ *Section 2*

Annual Surveys - Hull and machinery requirements

2.1 General

2.1.1 Annual Surveys are to be held concurrently with statutory annual or other relevant statutory surveys, wherever practicable.

2.1.2 At Annual Surveys, the Surveyor is to examine the ship and machinery, so far as necessary and practicable, in order to be satisfied as to their general condition.

2.1.3 For additional requirements for ships for liquefied gases, see *Pt 1, Ch 3, 9 Ships for liquefied gases*.

2.1.4 For ships which are required by International Convention to comply with the *ISM Code - International Management Code and Revised Guidelines on Implementation of the ISM Code* (ISM Code), the Surveyor is to review the overall effectiveness of the Code onboard ship. This is to be undertaken regardless of the organisation issuing the Safety Management Certificate (SMC).

2.1.5 For ships assigned the notation 'laid-up', in lieu of the normal Annual Survey requirements a general examination of the hull and machinery is to be carried out.

2.2 Annual Surveys

2.2.1 The survey is to include:

- (a) An examination for the purpose of ensuring, as far as practicable, that the hull, hatch covers, hatch coamings, closing appliances, equipment and related piping are maintained in a satisfactory condition.
- (b) Examination of weather decks, ship side plating above the waterline, hatch cover and coamings.
- (c) Examination of watertight penetrations as far as practicable.
- (d) Examination of the weld connection between air pipes, ventilators and deck plating.
- (e) External examination of all air pipe heads installed on exposed decks.
- (f) Examination of flame screens on air pipes to all bunker tanks.
- (g) Examination of ventilators including closing devices, if any.
- (h) The Surveyor is to be satisfied regarding the efficient condition of:
 - exposed casings, skylights, flush deck scuttles, deckhouses and companionways, superstructure bulkheads, side, bow and stern doors, side scuttles and deadlights, chutes and other openings, together with all closing appliances.
 - scuppers and sanitary discharges (so far as practicable); valves on discharge lines (so far as practicable) and their controls; guard rails and bulwarks; freeing ports, gangways and life-lines; fittings and appliances for timber deck cargoes.
 - bilge level detection and alarm systems on ships assigned a **UMS** notation.

2.2.2 The following requirements for hatch covers and coamings are applicable:

- (a) The Surveyor is to obtain confirmation that no unapproved changes have been made to the hatch covers, hatch coamings and their securing and sealing devices since the previous survey.
- (b) Where mechanically operated steel hatch covers are fitted, Surveyors are to confirm the satisfactory condition of:
 - hatch covers;
 - tightness devices of longitudinal, transverse and intermediate cross junctions (gaskets, gasket lips, compression bars, drainage channels);
 - clamping devices, retaining bars, cleating;
 - chain or rope pulleys;
 - guides;
 - guide rails and track wheels;
 - stoppers, etc;
 - wires, chains, gypsies, tensioning devices;
 - hydraulic system essential to closing and securing;
 - safety locks and retaining devices.
- (c) Where portable hatch covers, wooden or steel pontoons are fitted, Surveyors are to confirm the satisfactory condition of:
 - wooden covers and portable beams, carriers or sockets for the portable beam, and their securing devices;
 - steel pontoons;
 - tarpaulins;
 - cleats, battens and wedges;
 - hatch securing bars and their securing devices;
 - loading pads/bars and the side plate edge;
 - guide plates and chocks;
 - compression bars, drainage channels and drain pipes (if any).

- (d) The Surveyor is to confirm the satisfactory condition of hatch coaming plating and their stiffeners, where applicable.
- (e) The Surveyor is to carry out random checking of the satisfactory operation of mechanically operated hatch covers including:
- stowage and securing in open condition,
 - proper fit and efficiency of sealing in closed condition,
 - operational testing of hydraulic and power components, wires, chains and link drives.
- (f) Where considered necessary by the Surveyor, the effectiveness of sealing arrangements may be proved by hose or chalk testing supplemented by dimensional measurements of seal compressing components.
- (g) For **general dry cargo ships** the survey is to include a close-up survey of the hatch covers, hatch coaming and stiffeners.
- (h) For **bulk carriers** the following requirements are also applicable:
- (i) The survey is to include a close-up survey of the hatch covers, hatch coaming and stiffeners.
 - (ii) A thorough survey of cargo hatch covers and coamings is only possible by their examination in an open and closed position, including verification of the proper opening and closing operation. As such, the hatch cover sets located in the forward 25 per cent of the ship's length and at least one other additional set are to be surveyed open, closed and in operation to the full extent on each direction in accordance with (*Pt 1, Ch 3, 2.2 Annual Surveys 2.2.2*) above. When selecting hatch cover sets it should be ensured that all sets are subject to survey at least once in every five-year Special Survey period. The closing of the covers is to include the fastening of all peripheral and cross joint cleats or other securing devices, with particular attention to be paid to the condition of the hatch covers located in the forward 25 per cent of the ship's length, where sea loads are normally greatest.
 - (iii) If there are indications of difficulty in operating and securing hatch covers, then additional sets are to be tested in operation at the discretion of the Surveyor.
 - (iv) Where the cargo hatch securing system does not function properly, repairs are to be carried out under the supervision of the Surveyor.
 - (v) Surveyors are to survey the sealing arrangements of perimeter and cross joints (gaskets for condition of permanent deformation, flexible seals on combination carriers, gasket lips, compression bars, drainage channels and non-return valves).

2.2.3 The Surveyor is to confirm that, where required, an approved loading instrument together with its operation manual are available on board, see *Pt 3, Ch 4, 8 Loading guidance information*. The operation of the loading instrument is to be verified in accordance with LR's certification procedure.

2.2.4 The anchoring and mooring equipment is to be examined so far as practicable.

2.2.5 The watertight doors in watertight bulkheads, their indicators and alarms, are to be examined and tested (locally and remotely), together with an examination of watertight bulkhead penetrations, so far as practicable.

2.2.6 The Surveyor is to examine and test in operation all main and auxiliary steering arrangements including their associated equipment and control systems, and verify that log book entries have been made in accordance with statutory requirements where applicable.

2.2.7 The Surveyor is to be satisfied regarding the freeboard marks on the ship's side.

2.2.8 The Surveyor is to generally inspect the machinery and boiler spaces, with particular attention being given to the propulsion system, auxiliary machinery and to the existence of any fire and explosion hazards. Emergency escape routes are to be checked to ensure that they are free of obstruction.

2.2.9 The means of communication between the navigating bridge and the machinery control positions, as well as the bridge and the alternative steering position, if fitted, are to be tested.

2.2.10 The bilge pumping systems for each watertight compartment, including bilge wells, extended spindles, self-closing drain cocks, valves fitted with rod gearing or other remote operation, pumps and level alarms, where fitted, are to be examined and operated as far as practicable and all confirmed to be satisfactory. Any hand pumps provided are to be included.

2.2.11 Piping systems containing fuel oil, lubricating oil or other flammable liquids are to be generally examined and operated as far as practicable, with particular attention being paid to tightness, fire precaution arrangements, flexible hoses and sounding arrangements.

2.2.12 The Surveyor is to be satisfied regarding the condition of non-metallic joints in piping systems which penetrate the hull, where both the penetration and the non-metallic joint are below the deepest load waterline.

2.2.13 The main propulsion, essential auxiliary and emergency generators including safety arrangements, controls and foundations are to be generally examined. Surveyors are to confirm that Periodical Surveys of engines have been carried out as required by the Rules and that safety devices have been tested.

2.2.14 The boilers, other pressure vessels and their appurtenances, including foundations, controls, high pressure and waste steam piping and insulation and gauges, are to be generally examined. Surveyors should confirm that Periodical Surveys of boilers and other pressure vessels have been carried out as required by the Rules.

2.2.15 For boilers, the safety devices are to be tested, and the safety valves are to be operated using the relieving devices. For exhaust gas heated economisers/boilers, the safety valves are to be tested at sea by the Chief Engineer and details recorded in the log book.

2.2.16 The operation and maintenance records, repair history and feed water chemistry records of boilers are to be examined.

2.2.17 For other pressure vessels, the safety devices are to be examined.

2.2.18 The electrical equipment and cabling forming the main and emergency electrical installations are to be generally examined under operating conditions so far as practicable. The satisfactory operation of the main and emergency sources of power and electrical services essential for safety in an emergency is to be verified; where the sources of power are automatically controlled they should be tested in the automatic mode. Bonding straps for the control of static electricity and earthing arrangements are to be examined where fitted.

2.2.19 The electrical installation in areas which may contain flammable gas or vapour and/or combustible dust is to be examined in order to verify that it is in good condition and has been properly maintained.

2.2.20 For main propulsion, essential auxiliary and emergency machinery control engineering systems, a general examination of the equipment and arrangements is to be carried out. Records of modifications are to be made available for review by the attending Surveyor. The documentation required by *Pt 6, Ch 1 Control Engineering Systems*, including configuration management, are to be reviewed following system modifications to confirm compliance with applicable Rules. Satisfactory operation of the safety devices and control systems is to be verified. For ships having **UMS** or **CCS** notation, a general examination of the control engineering equipment required for these notations is also to be carried out.

2.2.21 For ships fitted with an electronically controlled engine for main propulsion, essential auxiliary or emergency power purposes the following is to be carried out to the satisfaction of the Surveyor:

- (a) Verification of evidence of satisfactory operation of the engine and where possible this is to include a running test under load.
- (b) Verification of satisfactory operation of the safety devices and control, alarm and monitoring systems.
- (c) Verification that any changes to the software or control, alarm, monitoring and safety systems that affect the operation of the engine have been assessed by LR and are under configuration management control.

2.2.22 Dead ship starting arrangements for bringing machinery into operation without external aid are to be tested to the Surveyor's satisfaction.

2.2.23 On ships fitted with a dynamic positioning system, the control system and associated machinery items are to be generally examined and tested to demonstrate that they are in good working order.

2.2.24 For ships to which a **PM** or **PMC** notation has been assigned in accordance with *Pt 7, Ch 8, 1.2 Classification notations 1.2.1*, the thruster assisted positional mooring system, control system and associated machinery items are to be generally examined and tested under operating conditions to an approved Test Schedule.

2.2.25 For ships fitted with positional mooring equipment in accordance with *Pt 7, Ch 8 Positional Mooring and Thruster-Assisted Positional Mooring Systems*, a schedule or rota of moorings to be examined at Annual Survey should be agreed for component parts of the positional moorings.

2.2.26 For ships having an **OPS** notation assigned, a General Examination of on-shore power supply arrangements is to be carried out in accordance with *Pt 7, Ch 13 On-shore Power Supplies*.

2.2.27 For ships to which *Pt 6, Ch 4 Fire Protection, Detection and Extinction Requirements* applies, the arrangements for fire protection, detection and extinction are to be examined and are to include:

- (a) Verification, so far as practicable, that no significant changes have been made to the arrangement of structural fire protection.
- (b) Verification of the operation of manual and/or automatic doors where fitted.
- (c) Verification that fire-control plans are properly posted.
- (d) Examination, so far as possible, and testing as feasible, of the fire and/or smoke detection and alarm system(s).

- (e) Examination of fire main system, and confirmation that each fire pump, including the emergency fire pump can be operated separately so that the two required powerful jets of water can be produced simultaneously from different hydrants.
- (f) Verification that fire-hoses, nozzles, applicators and spanners are in good working condition and situated at their respective locations.
- (g) Examination of fixed fire-fighting systems controls, piping, instructions and marking, checking for evidence of proper maintenance and servicing, including date of last systems tests.
- (h) Verification that all portable and semi-portable fire-extinguishers are in their stowed positions, checking for evidence of proper maintenance and servicing, conducting random checks for evidence of discharged containers.
- (i) Verification, so far as practicable, that the remote control for stopping fans and machinery and shutting-off fuel supplies in machinery spaces and, where fitted, the remote controls for stopping fans in accommodation spaces and the means of cutting off power to the gallery are in good working order.
- (j) Examination of the closing arrangements of ventilators, funnel annular spaces, skylights, doorways and tunnels, where applicable.
- (k) Verification that the firemen's outfits are complete and in good condition.

2.2.28 The examination of salt-water ballast tanks is to be carried out as follows:

- (a) Salt-water ballast tanks, other than double bottom ballast tanks, on all ships (excluding oil tankers and chemical tankers) where it has been identified at a previous Special Survey or Intermediate Survey that:
 - (i) A hard protective coating has not been applied from the time of construction; or
 - (ii) A soft or semi-hard coating has been applied; or
 - (iii) A hard protective coating is found to be in POOR condition, as defined in 1.5, and the hard protective coating is not repaired to the satisfaction of the Surveyor.

If the conditions listed above are applicable to double bottom ballast tanks, then these tanks may be subject to examination at the Annual Survey at the discretion of the Surveyor.

- (b) Salt-water ballast tanks on oil tankers (including ore/oil and ore/bulk/oil ships) and chemical tankers where it has been identified at a previous Special Survey or Intermediate Survey that:
 - (i) A hard protective coating has not been applied from the time of construction; or
 - (ii) A soft or semi-hard coating has been applied; or
 - (iii) The hard protective coating is found to be in less than GOOD condition, as defined in *Pt 1, Ch 3, 1.5 Definitions*, and the hard protective coating is not repaired to the satisfaction of the Surveyor.
- (c) The examination of the salt-water ballast tanks, in accordance with the above, is to include thickness measurements to confirm the condition of the hull structure.

2.2.29 The Surveyor is to carry out an examination and thickness measurement of structure identified at the previous Special Survey or Intermediate Survey as having substantial corrosion, as defined in *Pt 1, Ch 3, 1.5 Definitions*. This requirement does not apply to cargo tanks of oil tankers and chemical tankers. The extent of thickness measurements is to be in accordance with the appropriate Tables in Sections *Pt 1, Ch 3, 5 Special Survey - General - Hull requirements, Pt 1, Ch 3, 6 Special Survey - Bulk carriers - Hull requirements, Pt 1, Ch 3, 7 Special Survey - Oil tankers (including ore/oil ships and ore/bulk/oil ships) - Hull requirements* or *Pt 1, Ch 3, 8 Special Survey - Chemical Tankers - Hull requirements*, as applicable, to determine the full extent of the corrosion pattern. The survey will not be considered complete until these additional thickness measurements have been carried out. For cargo holds and ballast tanks of bulk carriers built in accordance with the IACS Common Structural Rules (CSR), the annual thickness measurement may be dispensed with where a protective coating has been applied in accordance with the coating manufacturer's requirements and is maintained in good condition. Steel renewal requirements have been separately determined according to date of contract for construction for:

- (a) cargo hold hatch covers and coamings under IACS UR S21 and UR S21A; and
- (b) bulk carriers' corrugated transverse watertight hold bulkheads under IACS UR S18.

Where the gauged thickness is within the range $t_{\text{net}} + 0,5 \text{ mm}$ and $t_{\text{net}} + 1,0 \text{ mm}$, a coating (applied in accordance with coating manufacturer's requirements) or annual gauging may be adopted as an alternative to steel renewal. See *Pt 1, Ch 3, 5.6 Thickness measurement 5.6.7, Pt 1, Ch 3, 6.7 Thickness measurement 6.7.5 and Pt 1, Ch 3, 7.7 Thickness measurement 7.7.4*.

2.2.30 For **oil tankers** (including ore/bulk/oil ships and ore/oil ships), in addition to the applicable requirements of *Pt 1, Ch 3, 2.2 Annual Surveys 2.2.1 to Pt 1, Ch 3, 2.2 Annual Surveys 2.2.9*, the following are to be dealt with where applicable:

- (a) Examination of cargo tank openings including gaskets, covers, coamings and screens.

- (b) Examination of cargo tank venting arrangements including secondary means of venting, or over/under pressure alarms where fitted, with associated pressure/vacuum valves and flame screens.
- (c) Examination of flame screens on vents to all bunker, oily ballast and oily slop tanks and void spaces, so far as practicable.
- (d) Examination of cargo, crude oil washing, bunker, ballast and vent piping systems together with flame arresters and pressure/vacuum valves, as applicable above the upper deck within the cargo tank area, including vent masts and headers.
- (e) Verification that no potential sources of ignition such as loose gear, excessive products in the bilges, excessive vapours, combustible materials, etc. are present in or near the cargo pump room and that access ladders are in good condition.
- (f) Examination of cargo pump rooms and pipe tunnels (where fitted) and examination of all pump room bulkheads for signs of leakage or fractures and, in particular, the sealing arrangements of all penetrations in these bulkheads.
- (g) Verification that the pump room ventilation system is operational, ducting intact, dampers operational and screens are clean.
- (h) For ships to which *Pt 6, Ch 4 Fire Protection, Detection and Extinction Requirements* applies, the external examination of the piping and cut-out valves of cargo tank and cargo pump room fixed fire-fighting system.
- (i) For ships to which *Pt 6, Ch 4 Fire Protection, Detection and Extinction Requirements* applies, verification that the deck foam system and deck sprinkler system are in good operating condition.
- (j) Examination of the condition of all piping systems in the cargo pump room so far as practicable.
- (k) Examination, so far as practicable, of cargo, bilge, ballast and stripping pumps for excessive gland seal leakage, verification of proper operation of electrical and mechanical remote operating and shutdown devices and operation of pump room bilge system, and checking that pump foundations are intact.
- (l) Verification that installed pressure gauges on cargo discharge lines and level indicator systems are operational.
- (m) Verification that at least one portable instrument for measuring flammable vapour concentrations is available, together with a sufficient set of spares and a suitable means of calibration.
- (n) Examination of any inert gas system, see *Pt 1, Ch 3, 2.2 Annual Surveys 2.2.32*.
- (o) For ballast tanks, in areas where substantial corrosion, as defined in 1.5, has been noted then additional measurements are to be carried out in accordance with *Table 3.7.7 Thickness measurement - Single hull oil tankers, ore/oil ships and ore/bulk/oil ships - Bottom structure with substantial corrosion* to *Table 3.7.15 Thickness measurement - Double hull oil tankers - Transverse watertight and swash bulkhead structure in cargo tanks with substantial corrosion*, as applicable. The survey will not be considered complete until these additional thickness measurements have been carried out.
- (p) Verification that any special arrangements made for bow or stern loading and unloading are in good condition.

2.2.31 For **chemical tankers**, in addition to the applicable requirements of *Pt 1, Ch 3, 2.2 Annual Surveys 2.2.1* to *Pt 1, Ch 3, 2.2 Annual Surveys 2.2.30*, the following are to be dealt with, where applicable:

- (a) Examination of gauging devices, high level alarms and valves associated with overflow control.
- (b) Verification that any devices provided for measuring the temperature of the cargo and any associated alarms are satisfactory.
- (c) Examination of the cargo heating/cooling system sampling arrangements where fitted.
- (d) Verification that wheelhouse doors and windows, side scuttles and windows in superstructure and deckhouse ends facing the cargo area are in good condition.
- (e) Verification that pump discharge pressure gauges fitted outside the cargo pump rooms are satisfactory.
- (f) Verification that pumps, valves and pipelines are identified and distinctively marked.
- (g) Verification that the remote operation of the cargo pump room bilge system is satisfactory.
- (h) Verification that cargo pump room rescue arrangements are in order.
- (i) Verification that removable pipe lengths or other approved equipment necessary for cargo separation are available, and satisfactory.
- (j) Verification that the ventilation system including portable equipment, if any, of all spaces in the cargo area is operational.
- (k) Verification that arrangements are made for sufficient inert/padding/drying gas to be carried to compensate for normal losses and that means are provided for monitoring of ullage spaces.
- (l) Verification that arrangements are made for sufficient medium to be carried where drying agents are used on air inlets to cargo tanks.
- (m) Verification that suitable protective clothing is available for crew engaged in loading and discharging operations and that suitable storage is maintained.
- (n) Verification that the requisite safety equipment and associated breathing apparatus with requisite air supplies and emergency escape respiratory and eye protection, if required, are in good condition and are properly stowed.
- (o) Verification that medical first aid equipment including stretchers and oxygen resuscitation is in good condition and that satisfactory arrangements are made for antidotes for cargoes actually carried to be on board.
- (p) Verification that decontamination arrangements are operational.

- (q) Verification that the requisite gas detection instruments are on board and that satisfactory arrangements are made for the supply of any required vapour detection tubes.
- (r) Verification that the cargo sample stowage arrangements are in good condition.
- (s) Verification that, if applicable, the provisions made for chemicals which have special requirements listed in *Summary of Minimum Requirements of the Rules and Regulations for the Construction and Classification of Ships for the Carriage of Liquid Chemicals in Bulk, July 2015* are in order.
- (t) For ballast tanks, in areas where substantial corrosion, as defined in *Pt 1, Ch 3, 1.5 Definitions*, has been noted then additional measurements are to be carried out in accordance with *Table 3.8.5 Thickness measurement - Single and double hull chemical tankers - Bottom, inner bottom and hopper structure with substantial corrosion*, *Table 3.8.6 Thickness measurement - Single and double hull chemical tankers - Deck structure with substantial corrosion*, *Table 3.8.7 Thickness measurement - Single and double hull chemical tankers - Side shell and longitudinal bulkheads with substantial corrosion* and *Table 3.8.8 Thickness measurement - Single and double hull chemical tankers - Transverse watertight bulkheads and swash bulkheads with substantial corrosion*. The survey will not be considered complete until these additional thickness measurements have been carried out.

2.2.32 For **inert gas systems**, where fitted, the following are to be dealt with:

- (a) External examination of the condition of piping including vent piping above the upper deck in the cargo tank area and overboard discharges through the shell so far as practicable, together with components for signs of corrosion or gas leakage/effluent leakage.
- (b) Verification of the proper operation of both inert gas blowers.
- (c) Checking the scrubber room ventilation system.
- (d) Checking, so far as practicable, of the deck water seal for automatic filling and draining and checking for presence of water carry-over. Checking the operation of the non-return valve.
- (e) Testing of all remotely operated or automatically controlled valves including the flue gas isolating valve(s).
- (f) Checking the interlocking features of soot blowers.
- (g) Checking that the gas pressure regulating valve automatically closes when the inert gas blowers are secured.
- (h) Checking, so far as practicable, the following alarms and safety devices of the inert gas system using simulated conditions where necessary:
 - (i) high oxygen content of gas in the inert gas main;
 - (ii) low gas pressure in the inert gas main;
 - (iii) low pressure in the supply to the deck water seal;
 - (iv) high temperature of gas in the inert gas main;
 - (v) low water pressure to the scrubber;
 - (vi) accuracy of portable and fixed oxygen measuring equipment by means of calibration gas.

2.2.33 For **bulk carriers**, in addition to the applicable requirements of *Pt 1, Ch 3, 2.2 Annual Surveys 2.2.1 to Pt 1, Ch 3, 2.2 Annual Surveys 2.2.29*, the following are to be dealt with, where applicable:

- (a) Examination of cargo holds in accordance with *Table 3.2.1 Bulk carriers - Annual Surveys* is required.
- (b) Where substantial corrosion, as defined in *Pt 1, Ch 3, 1.5 Definitions*, has been noted then additional measurements are to be carried out in accordance with *Table 3.6.5 Thickness measurement - Single skin bulk carriers - Shell plating and stiffening, with substantial corrosion*, *Table 3.6.6 Thickness measurement - Single skin bulk carriers - Double bottom and hopper structure, with substantial corrosion*, *Table 3.6.7 Thickness measurement - Single and double skin bulk carriers - Transverse bulkheads in cargo holds, with substantial corrosion*, *Table 3.6.8 Thickness measurement - Single skin and double skin bulk carriers - Deck structure* with substantial corrosion*, *Table 3.6.9 Thickness measurement - Double skin bulk carriers - Double side space structure (including wing void spaces of ore carriers), with substantial corrosion* and *Table 3.6.10 Thickness measurement - Double skin bulk carriers - Double side space structure (including wing void spaces of ore carriers), with substantial corrosion*. The survey will not be considered complete until these additional thickness measurements have been carried out.

For cargo holds and ballast tanks of bulk carriers built in accordance with the IACS Common Structural Rules (CSR), the annual thickness measurement may be dispensed with where a protective coating has been applied in accordance with the coating manufacturer's requirements and is maintained in good condition. Steel renewal requirements have been separately determined according to date of contract for construction for:

- (a) cargo hold hatch covers and coamings under IACS UR S21; and
- (b) corrugated transverse watertight hold bulkheads under IACS UR S18.

Where the gauged thickness is within the range $t_{net} + 0,5$ mm and $t_{net} + 1,0$ mm, a coating (applied in accordance with coating manufacturer's requirements) or annual gauging may be adopted as an alternative to steel renewal. See *Pt 1, Ch 3, 5.6 Thickness measurement 5.6.7* and *Pt 1, Ch 3, 6.7 Thickness measurement 6.7.5*.

- (a) For ships fitted with water level detectors in cargo holds, ballast tanks forward of the collision bulkhead and any dry or void space which extends forward of the foremost cargo hold, an examination and a test, at random, of the water ingress detection systems and of their alarms is to be carried out.
- (b) For ships fitted with a means for draining and pumping ballast tanks forward of the collision bulkhead and the bilges of dry spaces, any part of which extends forward of the foremost cargo hold, an examination and a test of the draining and pumping systems, including their controls, is to be carried out.
- (c) Examination of bunker and vent piping systems, including ventilators.

2.2.34 For **general dry cargo ships**, in addition to the applicable requirements of *Pt 1, Ch 3, 2.2 Annual Surveys 2.2.1*, the following are required for ships over 10 years of age:

- (a) Overall survey of one forward and one after cargo hold and their associated 'tween deck spaces.
- (b) When considered necessary by the Surveyor, thickness measurement is to be carried out. If the results of thickness measurement indicate substantial corrosion, the extent of thickness measurement is to be in accordance with *Pt 1, Ch 3, 5 Special Survey - General - Hull requirements, Table 3.5.6 Thickness measurement - Additional requirements in way of structure identified with substantial corrosion*. The survey will not be considered complete until these additional thickness measurements have been carried out. Steel renewal requirements have been separately determined according to date of contract for construction for cargo hold hatch covers and coamings under IACS UR S21A. Where the gauged thickness is within the range $t_{net} + 0,5$ mm and $t_{net} + 1,0$ mm, a coating (applied in accordance with coating manufacturer's requirements) or annual gauging may be adopted as an alternative to steel renewal. See *Pt 1, Ch 3, 5.6 Thickness measurement 5.6.7*.

Table 3.2.1 Bulk carriers - Annual Surveys

Ships less than 10 years old	Ships between 10 and 15 years old	Ships greater than 15 years old
An Overall Survey of the forward cargo hold and an aft cargo hold on single skin ships See Note 1	(a) Overall Survey of <ul style="list-style-type: none"> (i) all cargo holds on single skin ships. (ii) two selected cargo holds on double skin ships. (b) Close-up Survey of at least 25 per cent of the cargo hold side shell frames, their lower end attachments and adjacent shell plating in the forward cargo hold on single skin ships (c) Examination of all piping and penetrations in cargo holds including overboard piping. See Notes 2, 3, 4, and 5	(a) Overall Survey of all cargo holds (b) Close-up Survey of at least 25 per cent of the cargo hold side shell frames, their lower end attachments and adjacent shell plating in the forward cargo hold and one other selected cargo hold on single skin ships (c) Examination of all piping and penetrations in cargo holds including overboard piping See Notes 2, 3, 4, and 5
<p>Note The requirements in this Table apply to both single skin and double skin ships, unless stated otherwise.</p> <p>Note 1. Where the Survey reveals the need for remedial measures, then the Survey is to be extended to include all cargo holds.</p> <p>Note 2. Close-up Survey is required within the area of the lower one-third of the length of the cargo hold side shell frames.</p> <p>Note 3. Where the Survey reveals the need for remedial measures, the Survey is to be extended to include a Close-up Survey of all of the cargo hold side shell frames and adjacent shell plating of that cargo hold, as well as a Close-up Survey of sufficient extent of all remaining cargo holds.</p>		

Note 4. When considered necessary by the Surveyor, thickness measurement is to be carried out. If the results of thickness measurement indicate substantial corrosion, the extent of thickness measurement is to be in accordance with Section 6, *Table 3.6.5 Thickness measurement - Single skin bulk carriers - Shell plating and stiffening, with substantial corrosion*, *Table 3.6.6 Thickness measurement - Single skin bulk carriers - Double bottom and hopper structure, with substantial corrosion*, *Table 3.6.7 Thickness measurement - Single and double skin bulk carriers - Transverse bulkheads in cargo holds, with substantial corrosion*, *Table 3.6.8 Thickness measurement - Single skin and double skin bulk carriers - Deck structure* with substantial corrosion*, *Table 3.6.9 Thickness measurement - Double skin bulk carriers - Double side space structure (including wing void spaces of ore carriers), with substantial corrosion* and *Table 3.6.10 Thickness measurement - Double skin bulk carriers - Double side space structure (including wing void spaces of ore carriers), with substantial corrosion* as applicable. The survey will not be considered complete until these additional thickness measurements have been carried out.

Note 5. Where protective coatings are found in GOOD condition, as defined in *Pt 1, Ch 3, 1.5 Definitions*, the extent of the Close-up Survey may be specially considered. When considered necessary by the Surveyor, thickness measurement is to be carried out. However, prior to any coating or recoating of cargo holds, scantlings are to be confirmed by thickness measurement with the Surveyor in attendance.

2.2.35 For **general dry cargo ships**, in addition to the applicable requirements of *Pt 1, Ch 3, 2.2 Annual Surveys 2.2.1*, the following are required for ships over 15 years of age:

- (a) Overall survey of all cargo holds and 'tween deck spaces.
- (b) Close-up Survey of at least 25 per cent of shell frames, including their end attachments and adjacent shell plating in a forward lower cargo hold and one other selected lower cargo hold. Close-up Survey is to include the lower one third length of the shell frames.
- (c) Where the survey reveals the need for remedial measures, then the survey is to be extended to include the Close-up Survey of all shell frames and adjacent shell plating in those cargo holds and associated tween deck spaces, as well as a Close-up Survey of sufficient extent of all remaining cargo holds and tween deck spaces.
- (d) Where the protective coatings in cargo holds are found in GOOD condition, as defined in *Pt 1, Ch 3, 1.5 Definitions*, the extent of Close-up Survey may be specially considered.
- (e) When considered necessary by the Surveyor, thickness measurement is to be carried out. If the results of thickness measurement indicate substantial corrosion, the extent of thickness measurement is to be in accordance with *Table 3.5.6 Thickness measurement - Additional requirements in way of structure identified with substantial corrosion* in *Pt 1, Ch 3, 5 Special Survey - General - Hull requirements*. The survey will not be considered complete until these additional thickness measurements have been carried out. Steel renewal requirements have been separately determined according to date of contract for construction for cargo hold hatch covers and coamings under IACS UR S21A. Where the gauged thickness is within the range $t_{net} + 0,5$ mm and $t_{net} + 1,0$ mm, a coating (applied in accordance with coating manufacturer's requirements) or annual gauging may be adopted as an alternative to steel renewal. See *Pt 1, Ch 3, 5.6 Thickness measurement 5.6.7*.

2.2.36 For **ship-borne barges** where surveys are permitted in accordance with *Pt 1, Ch 2, 3.5 Existing ships - Periodical Surveys 3.5.7*, see *Pt 1, Ch 3, 3 Intermediate Surveys - Hull and machinery requirements*.

2.2.37 For **roll on-roll off ships** (i.e. those that utilise a loading ramp which enables wheeled vehicles to be rolled on and rolled off the ship), in addition to the requirements of *Pt 1, Ch 3, 2.2 Annual Surveys 2.2.1*, the requirements of *Pt 1, Ch 3, 22 Bow, inner, side shell and stern doors on Ro-Ro ships* are to be complied with, as applicable. For ships other than roll on-roll off ships, fitted with bow doors, inner doors, side doors and stern doors, in addition to the requirements of *Pt 1, Ch 3, 2.2 Annual Surveys 2.2.1*, the following are to be satisfactorily dealt with, as applicable:

- (a) Verification of the freedom of movement of doors, and operation of their power units.
- (b) Examination of the door structure and surrounding ship structure.
- (c) Examination of the door sealing arrangements including gaskets and retaining bars.
- (d) Examination of the door cleating, locking and securing arrangements.
- (e) Examination of the door hinging arrangements.
- (f) Verification of the local and/or remote control of the securing devices/cleats.
- (g) Examination of all equipment associated with the opening, closing and securing of the door, e.g. wire ropes, chains, sheaves, rollers, guides, shackles, etc.
- (h) Verification of the tightness of the doors.
- (i) Examination and testing of remote control panels and associated indicator lights, closed circuit television systems, water leakage indicator lights and alarm systems.
- (j) Examination of the required notice boards and verification of log entries.

(k) Verification of the satisfactory testing of the bilge systems for the space between the inner and outer bow doors and of the vehicle deck.

(l) Verification that the approved Operation and Maintenance Manual is on board and satisfactorily maintained.

2.2.38 For **navigational arrangements for periodic one man watch** and **integrated bridge systems**, Annual Surveys are to be carried out in accordance with the approved test schedule as required by *Pt 7, Ch 9, 1.2 Information and plans required to be submitted 1.2.1* to ascertain that the equipment and arrangements required for the applicable class notation(s) are being maintained in good working order. At the time of the survey, relevant statutory certificates may be accepted as evidence of satisfactory operation.

2.2.39 For **liquefied gas ships**, see also *Pt 1, Ch 3, 9 Ships for liquefied gases*.

2.2.40 The Surveyor is to examine the fixed cargo securing fittings as far as necessary and practicable in order to be satisfied as to their general condition, see *Pt 3, Ch 14, 10 Surveys*.

2.2.41 Where the special features notation **CCSA** (certified container securing arrangements) is assigned, the Surveyor is to examine the securing arrangements including loose fittings so far as necessary and practicable in order to be satisfied as to their general condition, see *Pt 3, Ch 14, 10 Surveys*.

2.2.42 It is the responsibility of the onboard personnel to examine, maintain or renew cargo securing devices and maintain the appropriate certification. Records of inspections, maintenance and renewals, as well as the procedures for accepting, maintaining and repairing or rejecting cargo securing devices are to be kept onboard and made available to the attending Surveyor on request.

2.2.43 The Surveyor is to confirm that, for container ships which have the special features notation **BoxMax**, the onboard lashing program, together with its operation manual, is available on board, see *Pt 3, Ch 4, 8 Loading guidance information*. The operation of the program is to be verified in accordance with LR's certification procedure.

2.2.44 For single hold general dry cargo ships, other than bulk carriers, fitted with water level detectors in the cargo hold, an examination and a test, at random, of the water ingress detection system and alarms are to be carried out.

2.2.45 For **natural gas fuel installations** see also *Pt 1, Ch 3, 23.3 Annual Surveys – General Requirements for Fuel Systems to Pt 1, Ch 3, 23.6 Annual Survey - Fuel Bunkering System*

■ Section 3

Intermediate Surveys - Hull and machinery requirements

3.1 General

3.1.1 Intermediate Surveys are to be held concurrently with statutory annual or other relevant statutory surveys wherever practicable.

3.2 Intermediate Surveys

3.2.1 The requirements of *Pt 1, Ch 3, 2 Annual Surveys - Hull and machinery requirements* are to be complied with so far as applicable.

3.2.2 A general examination of salt water ballast tanks is to be carried out as required by *Pt 1, Ch 3, 3.2 Intermediate Surveys 3.2.6* and *Pt 1, Ch 3, 3.2 Intermediate Surveys 3.2.7*. For ships other than oil tankers and chemical tankers, if such examinations reveal no visible structural defects then the examination may be limited to a verification that the protective coating remains in GOOD or FAIR condition as defined in *Pt 1, Ch 3, 1.5 Definitions*.

3.2.3 In application of *Pt 1, Ch 3, 3.2 Intermediate Surveys 3.2.11*, *Pt 1, Ch 3, 3.2 Intermediate Surveys 3.2.13* and *Pt 1, Ch 3, 3.2 Intermediate Surveys 3.2.15* respectively for **oil tankers** (including ore/oil and ore/bulk/oil ships), **chemical tankers** and **bulk carriers** over 15 years of age a survey in dry-dock is to be a part of the Intermediate Survey. The overall and close-up surveys and thickness measurements, as applicable, of the lower portions of cargo tanks/holds and water ballast tanks are to be surveyed in accordance with the applicable requirements for Intermediate Surveys, if not already surveyed.

3.2.4 For **oil tankers** (including ore/oil and ore/bulk/oil ships) and **chemical tankers**, the condition of the corrosion prevention system identified during the Survey may result in the salt-water ballast tanks being subject to further examination at Annual Surveys, in accordance with *Pt 1, Ch 3, 2.2 Annual Surveys 2.2.28*.

3.2.5 For salt-water ballast tanks on those ships not listed in *Pt 1, Ch 3, 3.2 Intermediate Surveys 3.2.4*, the condition of the corrosion prevention system identified during the Survey may result in the tanks being subject to further examination at Annual Surveys, in accordance with *Pt 1, Ch 3, 2.2 Annual Surveys 2.2.28*. For double bottom ballast tanks, the examination at Annual Surveys will be at the discretion of the Surveyor.

3.2.6 For ships over 5 years of age and up to 10 years of age, representative salt-water ballast tanks are to be examined. In addition to this, the following requirements are applicable:

- (a) For **general dry cargo ships**, an Overall Survey of representative salt-water ballast tanks, as selected by the Surveyor is to be carried out.
- (b) For **bulk carriers**, an Overall Survey of representative salt-water ballast tanks, as selected by the Surveyor is to be carried out. The selected tanks are to include the fore peak tank, aft peak tank and a number of other tanks, taking into account the total number and type of ballast tanks.
- (c) For **single hull oil tankers** (including ore/oil and ore/bulk/oil ships), an examination of all salt-water ballast tanks is to be carried out. Where considered necessary by the Surveyor, thickness measurement and testing are to be carried out to ensure the structural integrity remains effective.
- (d) For **double hull oil tankers** and **chemical tankers**, an Overall Survey of representative salt-water ballast tanks, as selected by the Surveyor is to be carried out. If the survey reveals no visible defects, the examination may be limited to a verification that the hard protective coating remains in GOOD condition, as defined in *Pt 1, Ch 3, 1.5 Definitions*.
- (e) Where a hard protective coating is found to be in POOR condition, as defined in *Pt 1, Ch 3, 1.5 Definitions*, where a soft or semi-hard coating has been applied, where a protective coating was not applied from the time of construction or other defects are found, the survey is to be extended to other ballast tanks of the same type.

3.2.7 For all ships over 10 years of age, the following are required:

- (a) All salt-water ballast tanks are to be examined.
- (b) The anchors are to be partially lowered and raised using the windlass.

3.2.8 The Surveyor is to carry out an examination and thickness measurement of structure identified at the previous Special Survey as having substantial corrosion, see also *Pt 1, Ch 3, 5 Special Survey - General - Hull requirements, Pt 1, Ch 3, 6 Special Survey - Bulk carriers - Hull requirements, Pt 1, Ch 3, 7 Special Survey - Oil tankers (including ore/oil ships and ore/bulk/oil ships) - Hull requirements* and *Pt 1, Ch 3, 8 Special Survey - Chemical Tankers - Hull requirements*. In addition, for double hull oil tankers built in accordance with the IACS Common Structural Rules (CSR), the identified substantial corrosion areas are required to be examined and additional thickness measurements are to be carried out in accordance with *Table 3.7.11 Thickness measurement - Double hull oil tankers - Bottom, inner bottom and hopper structure with substantial corrosion* to *Table 3.7.15 Thickness measurement - Double hull oil tankers - Transverse watertight and swash bulkhead structure in cargo tanks with substantial corrosion*.

3.2.9 For all ships, the electrical generating sets are to be examined under working conditions to verify compliance with *Pt 6, Ch 2, 2.2 Number and rating of generators and converting equipment*.

3.2.10 In addition to the foregoing, in the case of all **oil tankers** (including ore/oil and ore/bulk/oil ships) the following are to be dealt with where applicable:

- (a) An examination of cargo, crude oil washing, bunker, ballast, steam and vent piping on the weather decks, as well as vent masts and headers. If upon examination there is any doubt as to the condition of the piping, the piping may be required to be pressure tested, gauged, or both.
- (b) A general examination within the zones and spaces deemed as hazardous, such as cargo pump rooms and spaces adjacent to and zones above cargo tanks, for defective and non-certified safe-type electrical equipment, improperly installed, defective and dead-end wiring. An electrical insulation resistance test of the circuits terminating in, or passing through, the hazardous zones and spaces is to be carried out. If the ship is not in a gas free condition the results of previously recorded test readings may be accepted.

3.2.11 For **oil tankers** (including ore/oil and ore/bulk/oil ships), in addition to *Pt 1, Ch 3, 3.2 Intermediate Surveys 3.2.10*, the following are required for ships over 10 years of age:

- (a) A survey to the same extent as the previous Special Survey (applicable only to ESP surveys, see *Pt 1, Ch 3, 7.1 General 7.1.2*).
- (b) Pressure testing of cargo and ballast tanks and the requirements for the longitudinal strength evaluation (see *Pt 1, Ch 3, 7.7 Thickness measurement 7.7.3*) are to be carried out if deemed necessary by the attending Surveyor.

3.2.12 For **chemical tankers**, in addition to the applicable requirements of *Pt 1, Ch 3, 3.2 Intermediate Surveys 3.2.1 to Pt 1, Ch 3, 3.2 Intermediate Surveys 3.2.9* the following are to be dealt with where applicable:

- (a) Examination of vent line drainage arrangements.
- (b) Verification that the cargo heating/cooling system is in good condition.
- (c) Verification that the ship's cargo hoses are approved and in good condition.
- (d) Verification that where applicable, pipelines and independent cargo tanks are electrically bonded to the hull.
- (e) An examination of cargo, cargo washing, bunker, ballast, steam and vent piping on the weather decks, as well as vent masts and headers. If upon examination there is any doubt as to the condition of the piping, the piping may require to be pressure tested, gauged or both.
- (f) A General Examination within the zones and spaces deemed as hazardous, such as cargo pump rooms and spaces adjacent to and zones above cargo tanks, for defective and non-certified safe-type electrical equipment, improperly installed, defective and dead-end wiring. An electrical insulation resistance test of the circuits terminating in, or passing through, the hazardous zones and spaces is to be carried out. If the ship is not in a gas free condition the results of previously recorded test readings may be accepted.

3.2.13 For **chemical tankers**, in addition to *Pt 1, Ch 3, 3.2 Intermediate Surveys 3.2.12*, the following are required for ships over 10 years of age:

- (a) A survey to the same extent as the previous Special Survey (applicable only to ESP surveys, see *Pt 1, Ch 3, 8.1 General 8.1.2*).
- (b) Pressure testing of cargo and ballast tanks is to be carried out if deemed necessary by the attending Surveyor.

3.2.14 For **bulk carriers**, in addition to the applicable requirements of *Pt 1, Ch 3, 3.2 Intermediate Surveys 3.2.1 to Pt 1, Ch 3, 3.2 Intermediate Surveys 3.2.9*, the following are to be dealt with on ships over five years of age:

- (a) Overall Survey, Close-up Survey and thickness measurements of cargo holds in accordance with *Table 3.3.1 Bulk carriers - Intermediate Surveys*.
- (b) For ore carriers, in addition to the requirements of *Pt 1, Ch 3, 3.2 Intermediate Surveys 3.2.7*, the examination of salt-water ballast tanks is to include the following:
 - (i) All web frame rings in one ballast wing tank.
 - (ii) One deck transverse in each remaining ballast wing tank.
 - (iii) Both transverse bulkheads in one ballast wing tank.
 - (iv) One transverse bulkhead in each remaining ballast wing tank.
- (c) Steel renewal requirements have been separately determined according to date of contract for construction for:
 - (i) cargo hold hatch covers and coamings under IACS UR S21; and
 - (ii) corrugated transverse watertight hold bulkheads under IACS UR S18.

Where the gauged thickness is within the range $t_{net} + 0,5$ mm and $t_{net} + 1,0$ mm, a coating (applied in accordance with coating manufacturer's requirements) or annual gauging may be adopted as an alternative to steel renewal. See *Pt 1, Ch 3, 5.6 Thickness measurement 5.6.7* and *Pt 1, Ch 3, 6.7 Thickness measurement 6.7.5*.

- (d) For bulk carriers built in accordance with the IACS Common Structural Rules (CSR), the areas identified with substantial corrosion in cargo holds and ballast tanks may be either:
 - (i) protected by coating applied in accordance with the coating manufacturer's requirements and examined at Annual Surveys to confirm the coating in way is still in GOOD condition, or alternatively;
 - (ii) subject to thickness measurement at Annual Surveys.

3.2.15 For **bulk carriers**, in addition to the applicable requirements of *Pt 1, Ch 3, 3.2 Intermediate Surveys 3.2.1 to Pt 1, Ch 3, 3.2 Intermediate Surveys 3.2.9*, the following is required for ships over 10 years of age:

- (a) A survey to the same extent as the previous special Survey (applicable to ESP surveys, see *Pt 1, Ch 3, 6.1 General 6.1.2*).
- (b) Pressure testing of all tanks and the internal examination of fuel oil tanks are to be carried out if deemed necessary by the Surveyor.

3.2.16 For ships over 10 years old of age (other than dry cargo ships, general dry cargo ships, ships assigned **ESP** Notation and ships for liquefied gases), in addition to the applicable requirements of *Pt 1, Ch 3, 3.2 Intermediate Surveys 3.2.1 to Pt 1, Ch 3, 3.2 Intermediate Surveys 3.2.8*, an Overall Survey of selected cargo spaces is to be carried out.

3.2.17 For **dry cargo ships** over 15 years old (other than bulk carriers and general dry cargo ships), in addition to the applicable requirements of *Pt 1, Ch 3, 3.2 Intermediate Surveys 3.2.1 to Pt 1, Ch 3, 3.2 Intermediate Surveys 3.2.8*, an Overall Survey of selected cargo holds is to be carried out.

3.2.18 For **general dry cargo ships**, in addition to the applicable requirements of *Pt 1, Ch 3, 3.2 Intermediate Surveys 3.2.1 to Pt 1, Ch 3, 3.2 Intermediate Surveys 3.2.9*, the following is required for ships over 5 years of age:

- An overall survey of one forward and one after cargo hold and their associated 'tween deck spaces.

3.2.19 For **general dry cargo ships**, in addition to the applicable requirements of *Pt 1, Ch 3, 3.2 Intermediate Surveys 3.2.1*, the following are required for ships over 10 years of age:

- An overall survey of all cargo holds and 'tween deck spaces.
- Where considered necessary by the Surveyor, thickness measurement is to be carried out. If the results of thickness measurement indicate substantial corrosion, the extent of thickness measurement is to be in accordance with *Table 3.5.6 Thickness measurement - Additional requirements in way of structure identified with substantial corrosion* in Section 5. The survey will not be considered complete until these additional thickness measurements have been carried out. Steel renewal requirements have been separately determined according to date of contract for construction for cargo hold hatch covers and coamings under IACS UR S21A. Where the gauged thickness is within the range $t_{net} + 0,5$ mm and $t_{net} + 1,0$ mm, a coating (applied in accordance with coating manufacturer's requirements) or annual gauging may be adopted as an alternative to steel renewal. See *Pt 1, Ch 3, 5.6 Thickness measurement 5.6.7*.

3.2.20 For **general dry cargo ships**, in addition to the applicable requirements of *Pt 1, Ch 3, 3.2 Intermediate Surveys 3.2.1*, the following are required for ships over 15 years of age:

- A survey to the same extent as the previous special Survey (applicable only to surveys of the hull structure and piping systems in way of the cargo holds, cofferdams, pipe tunnels and void spaces within the cargo area and all salt water ballast tanks).
- Tank testing, survey of automatic air pipe heads and internal examination of fuel oil, lubricating oil and fresh water tanks are to be carried out if deemed necessary by the Surveyor.

3.2.21 For **ship-borne barges**, where Intermediate Surveys are permitted as an alternative to Annual Surveys and Docking Surveys, all the hatch covers are to be hose tested at every survey. The external surfaces of the barges are to be surveyed at these surveys.

3.2.22 For **liquefied gas ships**, see *Pt 1, Ch 3, 9 Ships for liquefied gases*.

3.2.23 For **natural gas fuel installations** see also *Pt 1, Ch 3, 23.7 Intermediate Surveys*.

Table 3.3.1 Bulk carriers - Intermediate Surveys

	Ships between 5 and 10 years old	Ships between 10 and 15 years old	Ships greater than 15 years old
(a)	Overall Survey of all cargo holds, see Notes 1, 2, 3 and 4	A survey to the same extent as the previous Special Survey (applicable only to ESP surveys, see <i>Pt 1, Ch 3, 6.1 General 6.1.2</i>), see Note 3.	A survey to the same extent as the previous Special Survey (applicable only to ESP surveys, see <i>Pt 1, Ch 3, 6.1 General 6.1.2</i>), see Note 3.
(b)	Close-up Survey to establish the condition of at least 25 per cent of the cargo hold side shell frames including their upper and lower end attachments, adjacent shell plating and the transverse bulkheads in the forward cargo hold and one other selected cargo hold on single skin ships, see Notes 1, 3 and 4.		
<p>Note The requirements in this Table apply to both single skin and double skin ships, unless stated otherwise.</p> <p>Note 1. For single skin ships, where considered necessary by the Surveyor as a result of the Overall and Close-up Survey, the Survey is to be extended to include a Close-up Survey of all of the side shell frames and adjacent shell plating of that cargo hold, as well as a Close-up Survey of sufficient extent of all remaining cargo holds.</p> <p>Note 2. For double skin ships, where considered necessary by the Surveyor as a result of the Overall Survey, the Survey is to be extended to include a Close-up Survey of those areas of structure in cargo holds selected by the Surveyor.</p>			

Note 3. Thickness measurement is to be carried out of sufficient extent to determine the level of corrosion of those areas subject to Close-up Survey. If the results of thickness measurement indicate substantial corrosion, the extent of thickness measurement is to be in accordance with Section 6, *Table 3.6.5 Thickness measurement - Single skin bulk carriers - Shell plating and stiffening, with substantial corrosion* to *Table 3.6.10 Thickness measurement - Double skin bulk carriers - Double side space structure (including wing void spaces of ore carriers), with substantial corrosion*, as applicable. The survey will not be considered complete until these additional thickness measurements have been carried out.

Note 4. For ships between 5 and 10 years old where hard protective coatings in cargo holds are found to be in GOOD condition, as defined in *Pt 1, Ch 3, 1.5 Definitions*, the extent of Close-up Survey and thickness measurement may be specially considered but not dispensed with in its entirety. Prior to any coating or recoating of cargo holds, scantlings are to be confirmed by thickness measurement with the Surveyor in attendance.

■ Section 4

Docking Surveys and In-water Surveys - Hull and machinery requirements

4.1 General

4.1.1 At Docking Surveys or In-water Surveys the Surveyor is to examine the ship and machinery, so far as necessary and practicable, in order to be satisfied as to the general condition.

4.1.2 For **oil tankers** (including ore/oil and ore/bulk/oil ships), **chemical tankers** and **bulk carriers** over 15 years of age the intermediate docking between Special Surveys is to be held in dry-dock. Further, this survey is to be held as part of the Intermediate Survey.

4.2 Docking Surveys

4.2.1 Where a ship is in dry-dock or on a slipway it is to be placed on blocks of sufficient height, and proper staging is to be erected as may be necessary, for the examination of the shell including bottom and bow plating, keel, stern, sternframe and rudder. The rudder is to be lifted for examination of the pintles if considered necessary by the Surveyor.

4.2.2 The shell plating is to be examined for excessive corrosion, deterioration due to chafing or contact with the ground and for undue unfairness or buckling. Special attention is to be given to the connection between the bilge strakes and the bilge keels.

4.2.3 The clearances in the rudder bearings are to be measured. Where applicable, pressure testing of the rudder may be required if deemed necessary by the Surveyor.

4.2.4 The sea connections and overboard discharge valves and cocks and their attachments to the hull are to be examined.

4.2.5 The propeller, sternbush and sea connection fastenings and the gratings at the sea inlets are to be examined.

4.2.6 Visible parts of side thrusters are to be examined. Other propulsion systems which also have manoeuvring characteristics (such as directional propellers, vertical axis propellers, water jet units) are to be examined externally with focus on the condition of gear housing, propeller blades, bolt locking and other fastening arrangements. Sealing arrangements of propeller blades, propeller shaft and steering column are to be verified.

4.2.7 The clearance in the sternbush and the efficiency of the oil glands are to be ascertained.

4.2.8 When chain cables are ranged, the anchors and cables are to be examined by the Surveyor, *see also Pt 1, Ch 3, 5.3 Examination and testing 5.3.13, Pt 1, Ch 3, 5.3 Examination and testing 5.3.14, Pt 1, Ch 3, 5.3 Examination and testing 5.3.16 and Table 3.5.1 Survey preparation.*

4.2.9 Where the anti-fouling system is changed completely, or partial repair is carried out affecting 25 per cent or more of the antifouling system, the coating specification and anti-fouling system is to be examined by the Surveyor in accordance with the *AFS - International Convention on the Control of Harmful Anti-Fouling Systems on Ships, 2001 (AFS 2001)* and *Ch 15 Corrosion Prevention* of the Rules for Materials.

4.2.10 Where the antifouling system is changed completely, or partial repair is carried out affecting 25 per cent or more of the antifouling system, the coating specification and antifouling system is to be examined by the Surveyor in accordance with IMO Antifouling System Convention.

4.3 In-water Surveys

4.3.1 The Committee will accept an In-water Survey in lieu of the intermediate docking between Special Surveys required in a five year period on ships other than those covered in *Pt 1, Ch 3, 4.1 General 4.1.2* and where an ***IWS** notation is assigned, see *Pt 1, Ch 2, 2.3 Class notations (hull) 2.3.11*.

4.3.2 The Committee may accept an In-water Survey in lieu of the intermediate docking between Special Surveys required in a five year period on ships where suitable protection is applied to the underwater portion of the hull. If requested, and providing that there is suitable access for the taking of rudder pintle and bush clearances and for verifying the security of pintles in their sockets while the vessel is afloat, an ***IWS** notation may be assigned on satisfactory completion of the Survey, provided that the applicable requirements of LR's Rules and Regulations are complied with, see also *Pt 1, Ch 2, 2.3 Class notations (hull) 2.3.11*.

4.3.3 The In-water Survey is to provide the information normally obtained from the Docking Survey.

4.3.4 When there is no access, special consideration shall be given to ascertaining rudder bearing clearances and sternbush clearances based on a review of the operating history, on board testing and stern bearing oil analysis. These considerations are to be included in the proposals for In-water Surveys which are to be submitted in advance of the survey being required, so that satisfactory arrangements can be agreed with LR.

4.3.5 The In-water Survey is to be carried out at an agreed geographical location under the surveillance of a Surveyor to LR, with the ship at a suitable draught in sheltered waters and with weak tidal streams and currents. The in-water visibility and the cleanliness of the hull below the waterline is to be clear enough to permit a meaningful examination which allows the Surveyor and diver to determine the condition of the plating, appendages and the welding. The Surveyor is to be satisfied that the method of pictorial presentation is satisfactory. There is to be good two-way communication between the Surveyor and the diver.

4.3.6 Prior to commencing the In-water Survey, the equipment and procedures for both observing and reporting the survey are to be agreed between the Owners, the Surveyor and the diving firm.

4.3.7 The In-water Survey is to be carried out by a qualified diver employed by a firm approved by LR. In addition, for certain aspects of the In-water Survey, consideration may be given to the use of a Remotely Operated Vehicle (ROV) operated by the LR approved firm.

4.3.8 If the In-water Survey reveals damage or deterioration that requires early attention, the Surveyor may require that the ship be dry-docked in order that a fuller survey can be undertaken and the necessary work carried out.

4.3.9 Where a vessel has an ***IWS** notation, the condition of the high resistance paint is to be confirmed at each dry-docking in order that the ***IWS** notation can be maintained.

4.3.10 Some National Administrations may have requirements additional to those of *Pt 1, Ch 3, 4.3 In-water Surveys 4.3.1* to *Pt 1, Ch 3, 4.3 In-water Surveys 4.3.9*.

■ Section 5

Special Survey - General - Hull requirements

5.1 General

5.1.1 The survey is to be of sufficient extent to ensure that the hull and related piping are in satisfactory condition and are fit for the intended purpose for the new period of class of five years to be assigned, subject to proper maintenance and operation and to periodical surveys being carried out as required by the Regulations.

5.1.2 The requirements of *Pt 1, Ch 3, 2 Annual Surveys - Hull and machinery requirements* are to be complied with as applicable for all ships.

5.1.3 Additional requirements for **general dry cargo ships** are given in this Section; **dry bulk cargo ships bulk carriers** in *Pt 1, Ch 3, 6 Special Survey - Bulk carriers - Hull requirements*; **oil tankers** (including ore/oil ships and ore/bulk/oil ships) in *Pt 1, Ch 3, 7 Special Survey - Oil tankers (including ore/oil ships and ore/bulk/oil ships) - Hull requirements*; **chemical tankers** in *Pt 1, Ch 3, 8 Special Survey - Chemical Tankers - Hull requirements*; **ships for liquefied gases** in *Pt 1, Ch 3, 9 Ships for liquefied gases*.

5.1.4 A Docking Survey in accordance with the requirements of *Pt 1, Ch 3, 4 Docking Surveys and In-water Surveys - Hull and machinery requirements* is to be carried out as part of the Special Survey.

5.1.5 During the Docking Survey, for general dry cargo ships, oil tankers (including ore/oil ships and ore/bulk/oil ships), chemical tankers and bulk carriers, the overall and close-up surveys and thickness measurements, as applicable, of the lower portions of the cargo spaces and ballast tanks are to be carried out as required, if not already surveyed.

5.1.6 For ships assigned the notation 'laid-up', an Underwater Examination (UWE) and general examination of hull and machinery is to be carried out in lieu of the normal Special Survey requirements.

5.1.7 For roll on-roll off ships (i.e. those fitted with a loading ramp which enables wheeled vehicles to be rolled on and rolled off the ship), in addition to the requirements of this Section, the requirements of *Pt 1, Ch 3, 22 Bow, inner, side shell and stern doors on Ro-Ro ships* are to be complied with, as applicable.

5.2 Preparation

5.2.1 The ship is to be prepared for Overall Survey in accordance with the requirements of *Table 3.5.1 Survey preparation*. The preparation should be of sufficient extent to facilitate an examination to ascertain any significant corrosion, deformation, fractures, damages and other structural deterioration.

Table 3.5.1 Survey preparation

Special Survey I (Ships 5 years old)	Special Survey II (Ships 10 years old)	Special Survey III (Ships 15 years old)
<p>(1) The holds, 'tween decks, peaks, deep tanks, engine and boiler spaces, and other spaces, are to be cleared and cleaned as necessary, and the bilges and limbers all fore and aft are to be cleaned and prepared for examination. Platform plates in engine and boiler spaces are to be lifted as may be necessary for the examination of the structure below. Where necessary, close and spar ceiling, lining and pipe casings are to be removed for examination of the structure</p> <p>(2) In ships having a single bottom, a sufficient amount of close ceiling is to be lifted all fore and aft on each side from the bottom and bilges to permit the structure below to be examined</p>	<p>In addition to the requirements for Special Survey I, the following are to be complied with:</p> <p>(1) A sufficient amount of ceiling in the holds and other spaces is to be removed from the bilges and inner bottom to enable the condition of the structure in the bilges, the inner bottom plating, pillar feet, and the bottom plating of bulkheads and tunnel sides to be examined. If the Surveyor deems it necessary, the whole of the ceiling is to be removed</p> <p>(2) In ships having a single bottom, the limber boards and ceiling equal to not less than three strakes, all fore and aft on each side are to be removed, one such strake being taken from the bilges. Where the ceiling is fitted in hatches, the whole of the hatches and at least one strake of ceiling in the bilges are to be removed. If the Surveyor deems it necessary the whole of the ceiling and limber boards are to be removed</p>	<p>In addition to the requirements for Special Survey II the following are to be complied with:</p> <p>(1) Ceiling in holds is to be removed in order to ascertain that the steelwork is in good condition, free from rust and coated. If the Surveyor is satisfied, after removal of portions of the ceiling then it need not all be removed</p> <p>(2) Portions of wood sheathing, or other covering, on steel decks are to be removed, as considered necessary by the Surveyor, in order to ascertain the condition of the plating</p>

<p>(3) In ships having a double bottom, a sufficient amount of ceiling is to be removed from the bilges and inner bottom to enable the condition of the plating to be ascertained. If it is found that the plating is clean and in good condition, and free from rust, the removal of the remainder of ceiling may be dispensed with. The Surveyor may waive the removal of heavy reinforced compositions if there is no evidence of leakages, cracking or other faults in the composition</p> <p>(4) Casings, ceilings or linings and loose insulation, where fitted, are to be removed for examination of plating and framing, as required by the Surveyor. Compositions on plating are to be examined and sounded, but need not be disturbed if found to be adhering satisfactorily to the plating. Where structural defects are identified, any applied composition is to be locally removed to enable further examination of the plating and adjacent frames, as required by the Surveyor</p> <p>(5) The steelwork is to be exposed and cleaned and rust removed as may be required for its proper examination by the Surveyor</p> <p>(6) All tanks are to be cleaned as necessary to permit examination, where this is required by <i>Table 3.5.2 Tank internal examination requirements</i></p> <p>(7) Casings or covers of air, sounding, steam and other pipes, spar ceiling and lining in way of the side scuttles are to be removed, as required by the Surveyor</p>	<p>(3) The chain locker is to be cleaned internally. The chain cables are to be ranged for inspection. The anchors are to be cleaned and placed in an accessible position for inspection</p>	<p>All subsequent Special Surveys</p> <p>In addition to the requirements for Special Survey III the following are to be complied with:</p> <p>(1) In refrigerated cargo spaces, sufficient insulation is to be removed in each of the chambers to enable the Surveyor to be satisfied as to the condition of the steel structure, and to enable the thickness of the structure to be ascertained as required by <i>Pt 1, Ch 3, 5.6 Thickness measurement</i></p>
---	--	--

5.3 Examination and testing

5.3.1 All spaces within the hull and superstructure are to be examined.

5.3.2 The requirements for tank internal examination are given in *Table 3.5.2 Tank internal examination requirements*.

Table 3.5.2 Tank internal examination requirements

Tank		Special Survey I (Ships 5 years old)	Special Survey II (Ships 10 years old)	Special Survey III (Ships 15 years old)	Special Survey IV and subsequent (Ships 20 years old and over)
(1)	Peaks	All tanks	All tanks	All tanks	All tanks
(2)	Salt water ballast, see Note 5	All tanks	All tanks	All tanks	All tanks
(3)	Lubricating oil	None	None	None	One tank
(4)	Fresh water	None	One tank	All tanks	All tanks
(5)	Fuel oil - in way of (i) Engine Room	None	None	One tank	One tank

	(ii) Cargo Area	None	One tank	Two tanks, Note 3	50% of tanks - Note 3 and 4.
<p>Note 1. The above requirements apply to integral tanks only.</p> <p>Note 2. Where a selected number of tanks are examined, then different tanks are to be examined at each Special Survey on a rotational basis.</p>			<p>Note 3. To include one deep tank, if any.</p> <p>Note 4. Where 50% of tanks are to be examined, a minimum of two tanks are required to be examined depending upon the overall number of tanks.</p> <p>Note 5. The requirements for Salt-water ballast tanks are applicable to Bilge water, Sewage and Grey water tanks.</p>		

5.3.3 For **oil tankers** (including ore/oil and ore/bulk/oil ships) and **chemical tankers**, the condition of the corrosion prevention system, where provided, is to be examined in cargo tanks and salt-water ballast tanks. When considered necessary by the Surveyor, thickness measurements are to be carried out. The condition of the corrosion prevention system identified during the Survey may result in the salt-water ballast tanks being subject to further examination at Annual Surveys, in accordance with *Pt 1, Ch 3, 2.2 Annual Surveys 2.2.28*.

5.3.4 For those ships not listed in *Pt 1, Ch 3, 5.3 Examination and testing 5.3.3*, the condition of the corrosion prevention system, where provided, in salt-water ballast tanks is to be examined. When considered necessary by the Surveyor, thickness measurements are to be carried out. The condition of the corrosion prevention system identified during the Survey may result in the salt-water ballast tanks being subject to further examination at Annual Surveys, in accordance with *Pt 1, Ch 3, 2.2 Annual Surveys 2.2.28*. For double bottom ballast tanks, the examination at Annual Surveys will be at the discretion of the Surveyor.

5.3.5 Double bottom, deep, ballast, peak and other tanks, including cargo holds assigned also for the carriage of salt water ballast, are to be tested with a head of liquid to the top of air pipes or to near the top of hatches for ballast/cargo holds. Boundaries of fuel oil, lubricating oil and fresh water tanks are to be tested with a head of liquid to the highest point that liquid will rise to under service conditions. Tank testing of fuel oil, lubricating oil and fresh water tanks may be specially considered based upon a satisfactory external examination of the tank boundaries, and a confirmation from the Master stating that the pressure testing has been carried out according to the requirements with satisfactory results. Surveyors may extend the testing as deemed necessary.

For **oil tankers** (including ore/oil and ore/bulk/oil ships) and **chemical tankers**, the minimum requirements for cargo tank testing are to be in accordance with Sections *Pt 1, Ch 3, 7.5 Testing* and *Pt 1, Ch 3, 8.5 Testing*, as applicable.

5.3.6 Where repairs are effected to the shell plating or bulkheads, any tanks in way are to be tested to the Surveyor's satisfaction on completion of these repairs.

5.3.7 On ship-borne barges, in lieu of water testing, tanks and cofferdams may be air tested.

5.3.8 In cases where the inner surface of the bottom plating is covered with cement, asphalt, or other composition, the removal of this covering may be dispensed with, provided that it is inspected, tested by beating or chipping, and found sound and adhering satisfactorily to the steel.

5.3.9 All decks, casings and superstructures are to be examined.

5.3.10 Wood decks or sheathing are to be examined. If decay or rot is found or the wood is excessively worn, the wood is to be renewed. When a wood deck, laid on stringers and ties, has worn by 15 mm or more, it is to be renewed. Attention is to be given to the condition of the plating under wood decks, sheathing or other deck covering. If it is found that such coverings are broken, or are not adhering closely to the plating, sections are to be removed as necessary to ascertain the condition of the plating, *see also Pt 1, Ch 3, 1.2 Surveys for damage or alterations 1.2.1*.

5.3.11 Mechanically-operated hatch covers are to be tested to confirm satisfactory operation including stowage; and securing in open condition; proper fit and efficiency of sealing in closed conditions; operational testing of hydraulic and power components, wires, chains and link drives. The effectiveness of sealing arrangements of all hatch covers is to be checked by carrying out hose testing or equivalent.

5.3.12 The masts and standing rigging are to be examined.

5.3.13 The anchors are to be examined. If the chain cables are ranged they are to be examined. If any length of chain cable is found to be reduced in mean diameter at its most worn part by 12 per cent or more from its nominal diameter, it is to be renewed. The windlass is to be examined. For equipment forming part of a positional mooring system, *see Pt 1, Ch 3, 5.3 Examination and testing 5.3.16*.

5.3.14 The chain cables are to be ranged and examined on all ships over five years old.

5.3.15 The Surveyor is to be satisfied that there are suitable mooring ropes when these are a Rule requirement.

5.3.16 On ships fitted with positional mooring equipment in accordance with *Pt 7, Ch 8 Positional Mooring and Thruster-Assisted Positional Mooring Systems*, or wire rope anchor cables in accordance with *Pt 3, Ch 13, 7 Equipment*, the anchors are to be cleaned and examined. Wire rope anchor cables are to be examined. If cables are found to contain broken, badly corroded or birdcaging wires they are to be renewed. Chain cables are to be ranged and examined. If any length of chain cable is found to be reduced in mean diameter at its most worn part by 12 per cent or more from its nominal diameter it is to be renewed. The windlass(es) or winches are to be examined.

5.3.17 The hand pumps, suction, watertight doors, air and sounding pipes are to be examined. In addition, the Surveyor is to internally and externally examine air pipe heads in accordance with the requirements of *Table 3.5.7 Air pipe head internal examination requirements (applicable for automatic air pipe heads installed on exposed decks of all ships except passenger ships)*.

5.3.18 The Surveyor is to be satisfied as to the efficient condition of the following:

- (a) For ships to which *Pt 6, Ch 4 Fire Protection, Detection and Extinction Requirements* applies, means of escape from crew and passenger spaces, and spaces in which crew are normally employed.
- (b) Helm indicator, protection of aft steering wheel and gear.

5.3.19 Where the special features notation **CCSA** (certified container securing arrangements) is assigned, the Surveyor is to be satisfied as to the efficient condition of:

- (a) Cell guide structure including the connections between vertical cell guides and cross ties.
- (b) Cell guide entry devices.
- (c) Portable frameworks or other forms of structural restraints.
- (d) Fittings attached to the ship structure, with special attention to any signs of leakage in way of tanks or deck and shell plating.
- (e) End connecting pieces for lashings, twist locks and other loose fittings, which are to be examined and verified with the Register, see *Pt 3, Ch 14, 10 Surveys*.
- (f) Lashings, rods, wire ropes, and chains together with turn buckles and other tightening devices are to be examined and verified with the Register as far as necessary and practicable in order to be satisfied as to their general condition, see *Pt 3, Ch 14, 10 Surveys*.
- (g) Lashing wire ropes, which are to be renewed where more than five per cent of the wires are broken, worn or corroded in any length of 10 diameters of the wire rope.
- (h) Chains, which are to be renewed where worn or damaged.

Where renewals are required, the new item is to be of approved type and manufacture. Where test certificates are not available, the item is to be tested in accordance with *Pt 3, Ch 14, 3 Loose container securing fittings, materials and testing*.

5.3.20 It is the responsibility of the onboard personnel to examine, maintain or renew cargo securing devices and maintain the appropriate certification. Records of inspections, maintenance and renewals, as well as the procedures for accepting, maintaining and repairing or rejecting cargo securing devices are to be kept onboard and made available to the attending Surveyor on request.

5.3.21 All bilge and ballast piping systems are to be examined and operationally tested to working pressure, to the satisfaction of the Surveyor, to ensure that tightness and condition remain satisfactory.

5.3.22 For engine room and machinery space fire dampers the following is applicable:

- (a) At Special Survey I, Surveyors are to select and internally examine one engine room fire damper and one machinery space fire damper. Where considered necessary by the Surveyor as a result of the examinations, the extent of examinations may be extended to include other fire dampers.
- (b) At each subsequent Special Survey, all engine room and machinery space fire dampers are to be internally examined by the Surveyor.

Note The examination of fire dampers may be specially considered by the Surveyor where there is satisfactory documented evidence of their replacement within the previous five years.

5.3.23 In refrigerated cargo spaces, the condition of the coating and structure behind the insulation is to be examined at representative locations. Surveyors may limit the examination to the verification that the protective coating remains effective and that there are no visible structural defects. Where POOR coating condition is found, or structural defects are identified, then sufficient insulation is to be removed in each of the chambers in order to assess the condition of the remaining structure, as deemed necessary by the Surveyor. Additionally, where indents, scratches or other defects are identified during the survey of the shell plating from the outside, insulations in way are to be removed to enable further examination of the plating and adjacent frames, as required by the Surveyor.

5.4 Overall Survey

5.4.1 The following requirements are applicable to **general dry cargo ships**.

5.4.2 All cargo holds, salt-water ballast tanks including double bottom tanks, pipe tunnels, cofferdams and void spaces bounding cargo holds, decks and outer hull are to be examined, and this is to be supplemented by Close-up Survey, thickness measurement and testing as deemed necessary, to ensure that the structural integrity remains effective.

5.4.3 The examination is to be sufficient to ascertain substantial corrosion, significant deformation, fractures, damages or other structural deterioration and, if deemed necessary by the Surveyor, suitable non-destructive examination may be required.

5.4.4 All piping systems within the tanks and spaces indicated in *Pt 1, Ch 3, 5.4 Overall Survey 5.4.2* are to be examined and operationally tested to working pressure to the satisfaction of the Surveyor, to ensure that conditions remain satisfactory.

5.4.5 Where the salt-water ballast tanks have been converted to void spaces, the survey extent is to be specially considered based upon salt-water ballast tank requirements.

5.4.6 For single hold general dry cargo ships, other than bulk carriers, fitted with water level detectors in the cargo hold, an examination and a test of the water ingress detection system and alarms are to be carried out.

5.5 Close-up Survey

5.5.1 The following requirements are applicable to **general dry cargo ships**.

5.5.2 The minimum requirements for Close-up Survey are given in *Table 3.5.4 Close-up Survey - General dry cargo ships*. The Close-up Survey may be extended, as deemed necessary by the Surveyor, after taking into account the maintenance of the spaces under survey, the condition of the corrosion prevention system and where spaces have structural arrangements or details which have suffered defects in similar spaces or on similar ships according to available information.

5.5.3 For areas in tanks and cargo holds where coatings are found to be in GOOD condition, as defined in *Pt 1, Ch 3, 1.5 Definitions*, the extent of Close-up Surveys may be specially considered.

5.6 Thickness measurement

5.6.1 The general minimum requirements for thickness measurement are given in *Table 3.5.3 Thickness measurement - General*. For **general dry cargo ships**, the minimum requirements for thickness measurement are given in *Table 3.5.5 Thickness measurement - General dry cargo ships*. The Surveyor may extend the thickness measurements as deemed necessary.

Table 3.5.3 Thickness measurement - General

Special Survey I (Ships 5 years old)	Special Survey III (Ships 15 years old)	Special Survey IV and subsequent (Ships 20 years old and over)
(1) Critical areas, as required by the Surveyor	(1) Within 0,5L amidships; 2 transverse sections in way of two different cargo spaces, see Notes 2, 3 and 4	(1) Within 0,5L amidships; a minimum of 3 transverse sections in way of cargo spaces, see Notes 2, 3 and 4
Special Survey II (Ships 10 years old)	(2) All cargo hold hatch covers and coamings (plating and stiffeners)	(2) All cargo hold hatch covers and coamings (plating and stiffeners)
(1) Within 0,5L amidships; 1 transverse section of deck plating in way of a cargo space	(3) All transverse webs with associated plating and longitudinals, and the transverse bulkhead complete in the fore peak tank and aft peak tank, see Notes 3 and 5	(3) All exposed main deck plating over full length of ship
(2) Critical areas, as required by the Surveyor	(4) Critical areas, as required by the Surveyor	(4) All wind and water strakes over the full length of the ship, port and starboard
		(5) Representative exposed superstructure deck plating (i.e. poop, bridge and forecastle deck)

		<p>(6) Lowest strake and strakes in way of 'tween deck of all transverse bulkheads in cargo spaces together with internals in way, see Note 3</p> <p>(7) All transverse webs with associated plating and longitudinals, and the transverse bulkhead complete in the fore peak tank and aft peak tank, see Notes 3 and 5</p> <p>(8) All keel plates over the full length of the ship. Also additional bottom plates in way of cofferdams, machinery space and aft end of tanks</p> <p>(9) Plating of seachests. Also side shell plating in way of overboard discharges, as considered necessary by the Surveyor</p> <p>(10) Critical areas, as required by the Surveyor</p>
<p>Note 1. Thickness measurement locations are to be selected to provide the best representative sampling of areas likely to be most exposed to corrosion, considering cargo and ballast history and arrangement, and condition of protective coatings.</p> <p>Note 2. A transverse section is to include all longitudinal members such as plating, longitudinals and girders at the deck, sides, bottom, inner bottom, hopper side and longitudinal bulkheads, where fitted.</p> <p>Note 3. Where the protective coating is in GOOD condition, then the extent of thickness measurements of internals may be specially considered, but not dispensed with in its entirety, at the discretion of the Surveyor.</p> <p>Note 4. For ships having length L less than 100 m: (a) the number of transverse sections required at Special Survey III may be reduced to one; (b) the number of transverse sections required at Special Survey IV and subsequent surveys may be reduced to two; (c) at Special Survey III, thickness measurements of exposed deck plating within $0,5L$ amidships may be required.</p> <p>Note 5. Transverse bulkhead complete including stiffening system.</p> <p>Note 6. The requirements for thickness measurement for bulk carriers, oil tankers (including ore/oil and ore/bulk/oil ships), chemical tankers and ships for liquefied gases are given in <i>Pt 1, Ch 3, 6 Special Survey - Bulk carriers - Hull requirements</i>, <i>Pt 1, Ch 3, 7 Special Survey - Oil tankers (including ore/oil ships and ore/bulk/oil ships) - Hull requirements</i>, <i>Pt 1, Ch 3, 8 Special Survey - Chemical Tankers - Hull requirements</i> and <i>Pt 1, Ch 3, 9 Ships for liquefied gases</i> respectively.</p>		

Table 3.5.4 Close-up Survey - General dry cargo ships

Special Survey I (Ships 5 years old)	Special Survey II (Ships 10 years old)	Special Survey III (Ships 15 years old)	Special Survey IV and subsequent (Ships 20 years old and over)
(1) Selected shell frames in one forward and one aft cargo hold and associated tween deck spaces.	(1) Selected shell frames in all cargo holds and tween deck spaces.	(1) All shell frames in the forward lower cargo hold and 25% of shell frames in each remaining cargo hold and tween deck spaces, including their end attachments and adjacent shell plating.	(1) All shell frames in all cargo holds and tween deck spaces, including their end attachments and adjacent shell plating.

Periodical Survey Regulations

Part 1, Chapter 3 Section 5

(2) One selected cargo hold transverse bulkhead.	(2) One transverse bulkhead in each cargo hold, including stiffening system.	(2) All cargo hold transverse bulkheads, including stiffening system.	(2) All cargo hold transverse bulkheads, including stiffening system.
(3) All cargo hold hatch covers and coamings (plating and stiffeners).	(3) Forward and aft transverse bulkhead in one side ballast tank, including stiffening system.	(3) All transverse bulkheads in ballast tanks, including stiffening system.	(3) All transverse bulkheads in ballast tanks, including stiffening system.
	(4) One transverse web with associated plating and framing in two representative water ballast tanks of each type (i.e. topside, hopper side, side tank or double bottom tank).	(4) All transverse webs with associated plating and framing in each water ballast tank.	(4) All transverse webs with associated plating and framing in each water ballast tank.
	(5) All cargo hold hatch covers and coamings (plating and stiffeners).	(5) All cargo hold hatch covers and coamings (plating and stiffeners).	(5) All cargo hold hatch covers and coamings (plating and stiffeners).
	(6) Selected areas of all deck plating and underdeck structure inside the line of hatch openings between cargo hold hatches.	(6) All deck plating and underdeck structure and inside the line of hatch openings between cargo hold hatches.	(6) All deck plating and underdeck structure inside the line of hatch openings between cargo hold hatches.
	(7) Selected areas of inner bottom plating.	(7) All areas of inner bottom plating.	(7) All areas of inner bottom plating.

Note 1. Close-up survey of cargo hold transverse bulkheads to be carried out at the following areas: (i) Immediately above the inner bottom and immediately above the tween decks, as applicable. (ii) Mid-height of the bulkhead for the holds without tween decks. (iii) Immediately below the main deck plating and tween deck plating.

Note 2. Ballast tank includes peak tanks.

Table 3.5.5 Thickness measurement - General dry cargo ships

Special Survey I (Ships 5 years old)	Special Survey III (Ships 15 years old)	Special Survey IV and subsequent (Ships 20 years old and over)
(1) Critical areas, as required by the Surveyor.	(1) Within 0,5L amidships; 2 transverse sections in way of two different cargo spaces, see Notes 2, 3 and 4.	(1) Within 0,5L amidships; a minimum of 3 transverse sections, see Notes 2, 3 and 4
Special Survey II (Ships 10 years old)	(2) Measurements for the general assessment and recording of corrosion pattern of those structural members subject to Close-up Survey in accordance with <i>Table 3.5.4 Close-up Survey - General dry cargo ships</i> , see Note 5.	(2) Measurements for the general assessment and recording of corrosion pattern of those structural members subject to Close-up Survey in accordance with <i>Table 3.5.4 Close-up Survey - General dry cargo ships</i> , see Note 5.
(1) Within 0,5L amidships; 1 transverse section of deck plating in way of a cargo space.	(3) Within the cargo length area; (i) Each deck plate outside the line of cargo hatch openings. (ii) All wind and water strakes.	(3) Within the cargo length area; (i) Each deck plate outside the line of cargo hatch openings. (ii) Each bottom plate, including turn of bilge. (iii) Duct keel or pipe tunnel plating and internals.

<p>(2) Measurements for the general assessment and recording of corrosion pattern of those structural members subject to Close-up Survey in accordance with <i>Table 3.5.4 Close-up Survey - General dry cargo ships</i>, see Note 5.</p>	<p>(4) Selected wind and water strakes outside the cargo length area.</p> <p>(5) All cargo hold hatch covers and coamings (plating and stiffeners).</p>	<p>(4) All wind and water strakes over the full length of the ship, port and starboard.</p> <p>(5) All cargo hold hatch covers and coamings (plating and stiffeners).</p>
<p>(3) Critical areas, as required by the Surveyor.</p>	<p>(6) All transverse webs with associated plating and longitudinals, and the transverse bulkhead complete in the fore peak tank and aft peak tank, see Notes 3 and 6.</p> <p>(7) Critical areas, as required by the Surveyor</p>	<p>(6) Remaining exposed main deck plates not considered in item (3) and representative exposed superstructure deck plating (i.e. poop, bridge and forecastle deck).</p> <p>(7) Lowest strake and strakes in way of 'tween deck of all transverse bulkheads in cargo spaces together with internals in way, see Note 3.</p> <p>(8) All transverse webs with associated plating and longitudinals, and the transverse bulkhead complete in the fore peak tank and aft peak tank, see Note 3 and 6.</p> <p>(9) All keel plates over the full length of the ship. Also additional bottom plates in way of cofferdams, machinery spaces and aft end of tanks.</p> <p>(10) Plating of seachests. Also side shell plating in way of overboard discharges, as considered necessary by the Surveyor.</p> <p>(11) Critical areas, as required by the Surveyor</p>

Note 1. Thickness measurement locations are to be selected to provide the best representative sampling of areas likely to be most exposed to corrosion, considering cargo and ballast history and arrangement, and condition of protective coatings.

Note 2. A transverse section is to include all longitudinal members such as plating, longitudinals and girders at deck, sides, bottom, inner bottom, hopper side and longitudinal bulkheads, where fitted.

Note 3. Where the protective coating is in GOOD condition, then the extent of thickness measurements of internals may be specially considered, but not dispensed with in its entirety, at the discretion of the Surveyor.

Note 4. For ships having length *L* less than 100 m: (a) the number of transverse sections required at Special Survey III may be reduced to one. (b) the number of transverse sections required at Special Survey IV and subsequent surveys may be reduced to two.

Note 5. For areas in cargo holds and salt-water ballast tanks subject to Close-up Survey, the thickness measurements may be dispensed with provided the Surveyor is satisfied with the Close-up Survey examination, that there is no structural diminution and the protective coating remains effective.

Note 6. Transverse bulkhead complete including stiffening system.

5.6.2 Thickness measurements may be carried out in association with the fourth Annual Survey.

5.6.3 In areas where substantial corrosion, as defined in *Pt 1, Ch 3, 1.5 Definitions*, has been noted, then additional measurements are to be carried out, as applicable, in accordance with *Table 3.5.6 Thickness measurement - Additional requirements in way of structure identified with substantial corrosion* to determine the full extent of the corrosion pattern. The survey will not be considered complete until these additional thickness measurements have been carried out.

Table 3.5.6 Thickness measurement - Additional requirements in way of structure identified with substantial corrosion

Structural member	Extent of measurement	Pattern of measurement
Plating	Suspect areas and adjacent plates	5 point pattern over 1m ²
Stiffeners	Suspect areas	3 measurements each in line across web and flange

Table 3.5.7 Air pipe head internal examination requirements (applicable for automatic air pipe heads installed on exposed decks of all ships except passenger ships)

Special Survey I (Ships 5 years old)		Special Survey II (Ships 10 years old)		Special Survey III (Ships 15 years old) and subsequent
(1)	Two air pipe heads (one port and one starboard) on exposed decks in the forward 0,25L. See Notes 1 to 5	(1)	All air pipe heads on exposed decks in the forward 0,25L. See Notes 1 to 5	All air pipe heads on exposed decks. See Notes 1 to 6
(2)	Two air pipe heads (one port and one starboard) on the exposed decks, serving spaces aft of 0,25L. See Notes 1 to 5	(2)	At least 20% of air pipe heads on exposed decks, serving spaces aft of 0,25L. See Notes 1 to 5	

Note 1. Air pipe heads serving ballast tanks are to be selected where available.

Note 2. The Surveyor is to select which air pipe heads are to be examined.

Note 3. Where considered necessary by the Surveyor as a result of the examinations, the extent of examinations may be extended to include other air pipe heads on exposed decks.

Note 4. Where the inner parts of air pipe head cannot be properly examined due to its design, it is to be removed in order to allow an internal examination.

Note 5. Particular attention is to be given to the condition of the zinc coating in heads constructed from galvanised steel.

Note 6. Exemption may be considered for air pipe heads where there is documented evidence of their replacement within the previous five years.

5.6.4 Where substantial corrosion is identified and not rectified, this will be subject to examination and thickness measurement at Annual and Intermediate Surveys.

5.6.5 Where considered necessary by the Surveyor, thickness measurements are to be carried out in way of critical areas. These include areas considered prone to rapid wastage.

5.6.6 Where required by LR, a check of the buckling capacity of the upper deck is to be carried out for tankers having a length greater than 90 m.

5.6.7 Steel evaluation of hatch covers on exposed decks and hatch coamings and closing arrangements of cargo holds on ships with contract for construction on or after 1 July 2012 is to be in accordance with IACS UR S21A. Further information is provided in the LR document *Thickness Measurement and Close-Up Survey Guidance*.

5.6.8 Steel renewal is required where the gauged thickness is less than $t_{net} + 0,5$ mm. For definition of t_{net} , see Pt 4, Ch 7, 12.1 General 12.1.2.

5.6.9 Where the gauged thickness is within the range $t_{net} + 0,5$ mm and $t_{net} + 1,0$ mm, a coating (applied in accordance with coating manufacturer's requirements) or annual gauging may be adopted as an alternative to steel renewal.

■ Section 6

Special Survey - Bulk carriers - Hull requirements

6.1 General

6.1.1 The requirements of *Pt 1, Ch 3, 2 Annual Surveys - Hull and machinery requirements*, *Pt 1, Ch 3, 4 Docking Surveys and In-water Surveys - Hull and machinery requirements* and *Pt 1, Ch 3, 5 Special Survey - General - Hull requirements* are to be complied with as applicable.

6.1.2 In order to maintain and/or assign the **ESP** notation, the following requirements apply to the surveys of the hull structure and piping systems in way of the cargo holds, cofferdam, pipe tunnels, void spaces, topside tanks and double bottom tanks in way of the cargo hold area and all salt-water ballast tanks.

6.2 Documentation

6.2.1 The Owner is to obtain, supply and maintain documentation on board as follows:

- (a) A survey file comprising reports of structural surveys, thickness measurement and executive hull summary in accordance with the *2011 ESP Code – International Code on the Enhanced Programme of Inspections During Surveys of Bulk Carriers and Oil Tankers, 2011 – Resolution A.1049(27)*.
- (b) Supporting documentation consisting of:
 - (i) Main structural plans of cargo holds and ballast tanks (for ships built in accordance with the IACS Common Structural Rules (CSR), these plans are to include for each structural element, both the as-built and the renewal thickness. Any thickness for voluntary addition is also to be clearly indicated on the plans. The midship section plan to be supplied on board the ship is to include the minimum allowable hull girder sectional properties for the hold transverse section in all cargo holds).
 - (ii) Previous repair history.
 - (iii) Cargo and ballast history.
 - (iv) Records of inspections by ship's personnel with reference to structural deterioration in general, leakages in bulkheads and piping and the condition of the corrosion prevention systems, if any.
 - (v) Any other information that may help to identify critical structural areas and/or suspect areas requiring inspection.
 - (vi) Survey Programme as required by *Pt 1, Ch 3, 6.3 Planning for survey*.

The complete documentation in *Pt 1, Ch 3, 6.2 Documentation 6.2.1* is to be readily available for examination by the Surveyor and should be used as a basis for survey.

6.2.2 The documentation is to be kept on board for the lifetime of the ship.

6.3 Planning for survey

6.3.1 A Survey Programme is to be submitted by the Owner and is to include the proposals for survey, including the means of providing access for Close-up Survey, thickness measurement and tank testing and should take account of the information detailed in *Pt 1, Ch 3, 6.2 Documentation 6.2.1*.

6.3.2 Prior to the development of the Survey Programme, a Survey Planning Questionnaire is to be completed and submitted by the Owner, see *Pt 1, Ch 3, 1.6 Preparation for survey and means of access 1.6.15*.

6.4 Overall survey

6.4.1 All cargo holds, salt-water ballast tanks including double bottom tanks, pipe tunnels, cofferdams and void spaces bounding cargo holds, decks and outer hull are to be examined, and this examination is to be supplemented by Close-up Survey, thickness measurement and testing as applicable, to ensure that the structural integrity remains effective.

6.4.2 The examination is to be sufficient to ascertain substantial corrosion, significant deformation, fractures, damages or other structural deterioration and, if deemed necessary by the Surveyor, suitable non-destructive examination may be required.

6.4.3 Where substantial corrosion, as defined in *Pt 1, Ch 3, 1.5 Definitions*, is identified and is not rectified, this will be subject to re-examination at Annual and Intermediate Surveys.

6.4.4 All piping systems within the tanks and spaces indicated in *Pt 1, Ch 3, 6.4 Overall survey 6.4.1* are to be examined and tested under working conditions to ensure that the conditions remain satisfactory.

6.4.5 The extent of survey of combined salt-water ballast cargo holds is to be evaluated based on the records of ballast history, the extent and condition of the corrosion protection system provided, and the extent of structural diminution (corrosion).

6.4.6 Where salt-water ballast tanks have been converted to void spaces the survey extent is to be based upon salt-water ballast tank requirements.

6.4.7 Where provided, in association with a corrosion control **CC** special features notation, as defined in the *Register Book*, the condition of the protective coating or corrosion prevention system of cargo holds is to be examined.

6.4.8 For ships fitted with water level detectors in cargo holds, ballast tanks forward of the collision bulkhead and any dry or void space which extends forward of the foremost cargo hold, an examination and a test of the water ingress detection systems and of their alarms is to be carried out.

6.4.9 For ships fitted with a means for draining and pumping ballast tanks forward of the collision bulkhead and the bilges of dry spaces, any part of which extends forward of the foremost cargo hold, an examination and a test of the draining and pumping systems including their controls is to be carried out.

6.5 Testing

6.5.1 The minimum requirements for tank testing, as applicable, are given in *Pt 1, Ch 3, 5.3 Examination and testing 5.3.5*. Where required, the Surveyor may extend the tank testing if deemed necessary.

6.6 Close-up Survey

6.6.1 The minimum requirements for Close-up Survey are given in *Table 3.6.1 Close-up Survey - Single skin bulk carriers, Table 3.6.2 Close-up Survey - Double skin bulk carriers (excluding ore carriers)* and *Table 3.6.3 Close-up Survey - Ore carriers* as applicable.

6.6.2 The Close-up Survey may be extended, as deemed necessary by the Surveyor, after taking into account the maintenance of the spaces under survey, the condition of the corrosion prevention system and where spaces have structural arrangements or details which have suffered defects in similar spaces or on similar ships according to available information.

6.6.3 For areas in tanks and cargo holds where coatings are found to be in GOOD condition, as defined in *Pt 1, Ch 3, 1.5 Definitions*, the extent of Close-up Surveys may be specially considered.

Table 3.6.1 Close-up Survey - Single skin bulk carriers

Special Survey I (Ships 5 years old)	Special Survey II (Ships 10 years old)	Special Survey III (Ships 15 years old)	Special Survey IV (Ships 20 years old and over)
<p>(1) 25% of shell frames and their end attachments in the forward cargo hold at representative positions.</p> <p>(2) Selected shell frames and their end attachments in remaining cargo holds.</p> <p>(3) 1 transverse web with associated plating and longitudinals in 2 representative water ballast tanks of each type (i.e. topside or hopper side tank).</p> <p>(4) 2 selected cargo hold transverse bulkheads, including internal structure of upper and lower stools, where fitted. This is to include the aft bulkhead of the forward hold.</p> <p>(5) All cargo hold hatch covers and coamings (plating and stiffeners).</p>	<p>(1a) For bulk carriers with a deadweight less than 100,000 tonnes, all shell frames in the forward cargo hold and 25% of frames in each of the remaining cargo holds, including their end attachments and adjacent shell plating.</p> <p>(1b) For bulk carriers with a deadweight equal to or greater than 100,000 tonnes, all shell frames in the forward cargo hold and 50% of frames in each of the remaining cargo holds, including their end attachments and adjacent shell plating.</p> <p>(2) 1 transverse web with associated plating and longitudinals in each water ballast tank.</p> <p>(3) Forward and aft transverse bulkhead in 1 side ballast tank, including stiffening system.</p> <p>(4) All cargo hold transverse bulkheads including internal structure of upper and lower stools, where fitted.</p> <p>(5) All cargo hold hatch covers and coamings, (plating and stiffeners).</p> <p>(6) All deck plating and underdeck structure inside line of hatch openings between all cargo hold hatches.</p>	<p>(1) All shell frames in the forward and one other selected cargo hold and 50% of frames in each of the remaining cargo holds, including their end attachments and adjacent shell plating.</p> <p>(2) All transverse webs with associated plating and longitudinals in each water ballast tank.</p> <p>(3) All transverse bulkheads in ballast tanks, including stiffening system.</p> <p>(4) All cargo hold transverse bulkheads, including internal structure of upper and lower stools, where fitted.</p> <p>(5) All cargo hold hatch covers and coamings (plating and stiffeners).</p> <p>(6) All deck plating and underdeck structure inside line of hatch openings between all cargo hold hatches.</p>	<p>(1) All shell frames in all cargo holds, including their end attachments and adjacent shell plating.</p> <p>(2) All transverse webs with associated plating and longitudinals in each water ballast tank.</p> <p>(3) All transverse bulkheads in ballast tanks, including stiffening system.</p> <p>(4) All cargo hold transverse bulkheads, including internal structure of upper and lower stools, where fitted.</p> <p>(5) All cargo hold hatch covers and coamings (plating and stiffeners).</p> <p>(6) All deck plating and underdeck structure inside line of hatch openings between all cargo hold hatches.</p>

Note The requirements in this Table apply to all single skin bulk carriers unless stated otherwise.

Note 1. Ballast tank includes peak tanks.

Note 2. Close-up Survey of transverse bulkheads to be carried out at four levels:

Level (a) Immediately above the inner bottom and immediately above the line of gussets (if fitted) and shedders for ships without lower stool.

Level (b) Immediately above and below the lower stool shelf plate (for those ships fitted with lower stools), and immediately above the line of the shedder plates.

Level (c) About mid-height of the bulkhead.

Level (d) Immediately below the upper deck plating and immediately adjacent to the upper wing tank and immediately below the upper stool shelf plate for those ships fitted with upper stools, or immediately below the topside tanks.

Table 3.6.2 Close-up Survey - Double skin bulk carriers (excluding ore carriers)

Special Survey I (Ships 5 years old)	Special Survey II (Ships 10 years old)	Special Survey III (Ships 15 years old)	Special Survey IV (Ships 20 years old and over)
<p>(1) 1 transverse web with associated plating and longitudinals in 2 representative water ballast tanks of each type. This is to include the foremost topside and double side ballast tanks on either side</p> <p>(2) 2 selected cargo hold transverse bulkheads including internal structure of upper and lower stools, where fitted</p> <p>(3) All cargo hold hatch covers and coamings (plating and stiffeners)</p>	<p>(1) 1 transverse web with associated plating and longitudinals in each water ballast tank</p> <p>(2) Forward and aft transverse bulkheads, including stiffening system, in one complete double side ballast tank on one side of the ship (i.e. port or starboard), see Note 1</p> <p>(3) 25% of ordinary transverse web frames in the foremost double side tanks</p> <p>(4) One transverse bulkhead in each cargo hold including internal structure of upper and lower stools, where fitted</p> <p>(5) All cargo hold hatch covers and coamings (plating and stiffeners)</p> <p>(6) All deck plating and underdeck structure inside line of hatch openings between all cargo hold hatches</p>	<p>(1) All transverse webs with associated plating and longitudinals in each water ballast tank</p> <p>(2) All transverse bulkheads in ballast tanks, including stiffening system</p> <p>(3) 25% of ordinary transverse web frames in all double side tanks</p> <p>(4) All cargo hold transverse bulkheads including internal structure of upper and lower stools, where fitted</p> <p>(5) All cargo hold hatch covers and coamings (plating and stiffeners)</p> <p>(6) All deck plating and underdeck structure inside line of hatch openings between all cargo hold hatches</p>	<p>(1) All transverse webs with associated plating and longitudinals in each water ballast tank</p> <p>(2) All transverse bulkheads in ballast tanks, including stiffening system</p> <p>(3) All ordinary transverse web frames in all double side tanks</p> <p>(4) All cargo hold transverse bulkheads including internal structure of upper and lower stools, where fitted</p> <p>(5) All cargo hold hatch covers and coamings (plating and stiffeners)</p> <p>(6) All deck plating and underdeck structure inside line of hatch openings between all cargo hold hatches</p>

Note (1) Complete ballast tank means topside tank, hopper tank, double bottom tank and double side tank, even if these are separate.

Note (2) Ballast Tank includes peak tanks.

Note (3) Close-up survey of transverse bulkheads to be carried out at four levels: Level (a) Immediately above the inner bottom and immediately above the line of gussets (if fitted) and shedders for ships without lower stool. Level (b) Immediately above and below the lower stool shelf plate (for those ships fitted with lower stools), and immediately above the line of the shedder plates. Level (c) About mid-height of the bulkhead. Level (d) Immediately below the upper deck plating and immediately adjacent to the upper wing tank and immediately below the upper stool shelf plate for those ships fitted with upper stools, or immediately below the topside tanks.

Table 3.6.3 Close-up Survey - Ore carriers

Special Survey I (Ships 5 years old)	Special Survey II (Ships 10 years old)	Special Survey III (Ships 15 years old)	Special Survey IV (Ships 20 years old and over)
(1) 1 web frame ring complete including adjacent structural members in a water ballast wing tank. (2) 1 transverse bulkhead lower part including girder system and adjacent structural members in a ballast tank. (3) 2 selected cargo hold transverse bulkheads, including internal structure of upper and lower stools where fitted, see Note 2. (4) All cargo hold hatch covers and coamings (plating and stiffeners).	(1) All web frame rings complete including adjacent structural members in a water ballast wing tank. (2) 1 deck transverse including adjacent structural members in each remaining water ballast tank. (3) Forward and aft transverse bulkheads including girder system and adjacent structural members in a ballast wing tank. (4) 1 transverse bulkhead lower part including girder system and adjacent structural members in each remaining ballast tank. (5) 1 transverse bulkhead in each cargo hold, including internal structure of upper and lower stools where fitted, see Note 2. (6) All cargo hold hatch covers and coamings (plating and stiffeners). (7) All deck plating and under deck structure inside line of hatch openings between all cargo hold hatches.	(1) All web frame rings complete including adjacent structural members in each water ballast tank. (2) All transverse bulkheads including girder system and adjacent structural members in each ballast tank. (3) 1 web frame ring complete including adjacent structural members in each wing void space. (4) Additional web frame rings including adjacent structural members in void spaces as deemed necessary by the Surveyor. (5) All cargo hold transverse bulkheads, including internal structure of upper and lower stools where fitted, see Note 2. (6) All cargo hold hatch covers and coamings (plating and stiffeners). (7) All deck plating and under deck structure inside line of hatch openings between all cargo hold hatches	(1) All web frame rings complete including adjacent structural members in each water ballast tank. (2) All transverse bulkheads including girder system and adjacent structural members in each ballast tank. (3) 1 web frame ring complete including adjacent structural members in each wing void space. (4) Additional web frame rings including adjacent structural members in void spaces as deemed necessary by the Surveyor. (5) All cargo hold transverse bulkheads, including internal structure of upper and lower stools where fitted, see Note 2. (6) All cargo hold hatch covers and coamings (plating and stiffeners). (7) All deck plating and under deck structure inside line of hatch openings between all cargo hold hatches.

Note (1) Ballast tank includes peak tanks.

Note (2) Close-up Survey of transverse bulkheads to be carried out at four levels:

Note Level (a) Immediately above the inner bottom and immediately above the line of gussets (if fitted) and shedders for ships without lower stool.

Note Level (b) Immediately above and below the lower stool shelf plate (for those ships fitted with lower stools), and immediately above the line of the shedder plates.

Note Level (c) About mid-height of the bulkhead.

Note Level (d) Immediately below the upper deck plating and immediately adjacent to the upper wing tank and immediately below the upper stool shelf plate for those ships fitted with upper stools, or immediately below the topside tanks.

6.7 Thickness measurement

6.7.1 The minimum requirements for thickness measurements are given in *Table 3.6.4 Thickness measurement - Single skin and double skin bulk carriers*, see also *Pt 1, Ch 3, 5.6 Thickness measurement*. For ships built in accordance with the IACS Common Structural Rules (CSR), refer to the LR document *Thickness Measurement and Close-Up Survey Guidance*.

6.7.2 In areas where substantial corrosion, as defined in *Pt 1, Ch 3, 1.5 Definitions*, has been noted then additional measurements are to be carried out, as applicable, in accordance with *Table 3.6.5 Thickness measurement - Single skin bulk carriers - Shell plating and stiffening, with substantial corrosion*, *Table 3.6.6 Thickness measurement - Single skin bulk carriers - Double bottom and hopper structure, with substantial corrosion*, *Table 3.6.7 Thickness measurement - Single and double skin bulk carriers - Transverse bulkheads in cargo holds, with substantial corrosion*, *Table 3.6.8 Thickness measurement - Single skin and double skin bulk carriers - Deck structure* with substantial corrosion*, *Table 3.6.9 Thickness measurement - Double skin bulk*

carriers - Double side space structure (including wing void spaces of ore carriers), with substantial corrosion and Table 3.6.10 Thickness measurement - Double skin bulk carriers - Double side space structure (including wing void spaces of ore carriers), with substantial corrosion to determine the full extent of the corrosion pattern. The survey will not be considered complete until these additional thickness measurements have been carried out. For bulk carriers built in accordance with the IACS Common Structural Rules (CSR), the areas identified with substantial corrosion may be either:

- (a) protected by coating applied in accordance with the coating manufacturer's requirements and examined at Annual Surveys to confirm the coating in way is still in GOOD condition, or alternatively;
- (b) subject to thickness measurement at Annual Surveys.

6.7.3 Thickness measurement is required to determine both general and local levels of corrosion in salt water ballast tanks and in the shell frames and their end attachments in all cargo holds. Thickness measurements are also to be carried out to determine the corrosion levels on the transverse bulkhead plating.

6.7.4 Single skin bulk carriers contracted for construction prior to 1 July 1998 are to undergo a re-assessment and evaluation of their cargo hold shell frames in accordance with the Provisional Rules for Existing Ships. The number of shell frames to be measured is equivalent to number of shell frames subject to Close-Up Survey (see Table 3.6.1 Close-up Survey - Single skin bulk carriers), with representative measurements to be taken at specific areas for each frame. The extent of thickness measurement may be specially considered, but not dispensed with in its entirety, by the Surveyor, provided the structural members indicate no thickness diminution with respect to the Rule thickness and the coating is found in 'as-new' condition (i.e. without breakdown or rusting). Repairs to shell frames are to be based upon the minimum thickness values shown in the evaluation records.

6.7.5 For bulk carriers built in accordance with the IACS Common Structural Rules (CSR), the ship's longitudinal strength is to be evaluated by using the thickness of structural members measured, renewed and reinforced, as appropriate, during the Special Surveys carried out after the ship reaches 15 years of age (or during the Special Survey No. 3, if this is carried out before the ship reaches 15 years) in accordance with the criteria for longitudinal strength of the ship's hull girder for CSR bulk carriers specified in Chapter 13 of CSR. For further details refer to the LR document *Thickness Measurement and Close-Up Survey Guidance*.

6.7.6 Steel renewal evaluation of corrugated transverse watertight bulkheads on bulk carriers of 150 m in length and above, intending to carry solid bulk cargoes having a density of $1,0 \text{ t/m}^3$ with contract for construction on or after 1 July 1998 is to be in accordance with IACS UR S18. These requirements are not applicable to bulk carriers with class notation ESN Hold 1 and ESN – All Holds, or ships built in accordance with the IACS Common Structural Rules (CSR). Further information is provided in the LR document *Thickness Measurement and Close-Up Survey Guidance*.

6.7.7 Steel renewal is required where the gauged thickness is less than $t_{\text{net}} + 0,5 \text{ mm}$. For definition of t_{net} , see Pt 4, Ch 7, 10.4 Vertically corrugated transverse watertight bulkheads – Application and definitions 10.4.10.

6.7.8 Where the gauged thickness is within the range $t_{\text{net}} + 0,5 \text{ mm}$ and $t_{\text{net}} + 1,0 \text{ mm}$, a coating (applied in accordance with coating manufacturer's requirements) or annual gauging may be adopted as an alternative to steel renewal.

6.7.9 Hatch covers of cargo holds' steel renewal evaluation of bulk carriers with contract for construction on or after 1 July 1998 is to be in accordance with IACS UR S21. These requirements are not applicable to ships built in accordance with the IACS Common Structural Rules (CSR). Further information is provided in the LR document *Thickness Measurement and Close-Up Survey Guidance*.

6.7.10 Steel renewal is required where the gauged thickness is less than $t_{\text{net}} + 0,5 \text{ mm}$. For definition of t_{net} , see Pt 4, Ch 7, 12.1 General 12.1.2.

6.7.11 Where the gauged thickness is within the range $t_{\text{net}} + 0,5 \text{ mm}$ and $t_{\text{net}} + 1,0 \text{ mm}$, a coating (applied in accordance with coating manufacturer's requirements) or annual gauging may be adopted as an alternative to steel renewal.

6.7.12 Steel renewal evaluation of hatch covers and hatch coamings of cargo holds on bulk carriers and ore carriers with contract for construction on or after 1 January 2004 is to be in accordance with IACS UR S21. These requirements are not applicable to ships built in accordance with the IACS Common Structural Rules (CSR). Further information is provided in the LR document *Thickness Measurement and Close-Up Survey Guidance*.

6.7.13 Steel renewal is required where the gauged thickness is less than $t_{\text{net}} + 0,5 \text{ mm}$. For definition of t_{net} , see Pt 4, Ch 7, 12.1 General 12.1.2.

6.7.14 Where the gauged thickness is within the range $t_{\text{net}} + 0,5 \text{ mm}$ and $t_{\text{net}} + 1,0 \text{ mm}$, a coating (applied in accordance with coating manufacturer's requirements) or annual gauging may be adopted as an alternative to steel renewal.

Table 3.6.4 Thickness measurement - Single skin and double skin bulk carriers

Special Survey I (Ships 5 years old)	Special Survey III (Ships 15 years old)	Special Survey IV and subsequent (Ships 20 years old and over)
<p>(1) Measurement, for general assessment and recording of corrosion pattern, of those structural members subject to Close-up Survey in accordance with <i>Table 3.6.1 Close-up Survey - Single skin bulk carriers, Table 3.6.2 Close-up Survey - Double skin bulk carriers (excluding ore carriers) or Table 3.6.3 Close-up Survey - Ore carriers.</i></p> <p>(2) Critical areas, as required by the Surveyor.</p>	<p>(1) Within the cargo length area:</p> <p>(a) Each deck plate outside line of cargo hatch openings.</p> <p>(b) 2 transverse sections, outside line of cargo hatch openings. (A minimum of 1 of the above transverse sections is to be within 0,5L amidships).</p>	<p>(1) Within the cargo length area:</p> <p>(a) Each deck plate outside line of cargo hatch openings.</p> <p>(b) 3 transverse sections, outside line of cargo hatch openings. (A minimum of 2 of the above transverse sections is to be within 0,5L amidships).</p> <p>(c) Each bottom plate.</p>
<p>Special Survey II (Ships 10 years old)</p> <p>(1) Within the cargo length area:</p> <p>(a) 2 sections of deck plating outside line of cargo hatch openings.</p> <p>(2) Measurement, for general assessment and recording of corrosion pattern, of those structural members subject to Close-up Survey in accordance with <i>Table 3.6.1 Close-up Survey - Single skin bulk carriers, Table 3.6.2 Close-up Survey - Double skin bulk carriers (excluding ore carriers) or Table 3.6.3 Close-up Survey - Ore carriers.</i></p> <p>(3) Wind and water strakes in way of the transverse sections considered in item (1).</p> <p>(4) Selected wind and water strakes outside the cargo length area.</p> <p>(5) Cargo hold shell frames on single skin ships, see Note 5.</p> <p>(6) Critical areas, as required by the Surveyor.</p>	<p>(2) Measurement, for general assessment and recording of corrosion pattern, of those structural members subject to Close-up Survey in accordance with <i>Table 3.6.1 Close-up Survey - Single skin bulk carriers, Table 3.6.2 Close-up Survey - Double skin bulk carriers (excluding ore carriers) or Table 3.6.3 Close-up Survey - Ore carriers.</i></p> <p>(3) All wind and water strakes within the cargo length area.</p> <p>(4) Selected wind and water strakes outside the cargo length area.</p> <p>(5) All cargo hatch covers and coamings (plating and stiffeners).</p> <p>(6) All transverse webs with associated plating and longitudinals, and the transverse bulkhead complete in the fore peak tank and aft peak tank, see Notes 1 and 3.</p> <p>(7) The aft bulkhead of the forward cargo hold, see Note 4.</p> <p>(8) Cargo hold shell frames on single skin ships, see Note 5.</p> <p>(9) Critical areas, as required by the Surveyor.</p>	<p>(2) Measurement, for general assessment and recording of corrosion pattern, of those structural members subject to Close-up Survey in accordance with <i>Table 3.6.1 Close-up Survey - Single skin bulk carriers, Table 3.6.2 Close-up Survey - Double skin bulk carriers (excluding ore carriers) or Table 3.6.3 Close-up Survey - Ore carriers.</i></p> <p>(3) All wind and water strakes over the full length of the ship, port and starboard.</p> <p>(4) All cargo hatch covers and coamings (plating and stiffeners).</p> <p>(5) Remaining exposed main deck plates not considered in item (1) and representative exposed superstructure deck plating (i.e. poop, bridge and forecastle deck).</p> <p>(6) All transverse webs with associated plating and longitudinals, and the transverse bulkhead complete in the fore peak tank and aft peak tank, see Notes 1 and 3.</p> <p>(7) All keel plates outside the cargo length area. Also additional bottom plates in way of cofferdams. Machinery space and aft end of tanks.</p> <p>(8) Plating of seachests. Also side shell plating in way of overboard discharges, as considered necessary by the Surveyor.</p> <p>(9) The aft bulkhead of the forward cargo hold on single skin ships, see Note 4.</p> <p>(10) Cargo hold shell frames on single skin ships, see Note 5.</p> <p>(11) Critical areas, as required by the Surveyor.</p>
<p>Note The requirements in this table apply to both single skin and double skin ships unless stated otherwise.</p>		

Note 1. For areas in spaces where coatings are found to be in GOOD condition, as defined in *Pt 1, Ch 3, 1.5 Definitions*, the extent of thickness measurement may be specially considered, but not dispensed with in its entirety. Prior to any coating or recoating of cargo holds, scantlings are to be confirmed by thickness measurement with the Surveyor in attendance.

Note 2. Transverse sections should be chosen where the largest reductions are likely to occur, or as revealed by deck plating measurement.

Note 3. Transverse bulkhead complete including stiffening system.

Note 4. For ships assigned the notations **ESN Hold No1 and ESN All Holds**, the corrugated part of the aft transverse bulkhead of the forward cargo hold is to be subject to thickness measurement. This is to include each vertical corrugation at its lower and middle level including shedder plates and gusset plates, where applicable.

Note 5. Single skin bulk carriers contracted for construction prior to 1 July 1998 are to undergo a re-assessment of their cargo hold shell frames in accordance with the Provisional Rules for Existing Ships. The number of shell frames to be measured is equivalent to the number of shell frames subject to Close-up survey (see *Table 3.6.1 Close-up Survey - Single skin bulk carriers*), with representative measurements to be taken at specific areas for each frame.

Table 3.6.5 Thickness measurement - Single skin bulk carriers - Shell plating and stiffening, with substantial corrosion

Structural member	Extent of measurement	Pattern of measurement
(1) Bottom and side shell plating	Suspect plate plus four adjacent plates	5 point pattern for each panel between longitudinals
(2) Bottom/side shell longitudinals	Minimum of three longitudinals in way of suspect areas	3 measurements in line across web and 3 measurements on flange
(3) Side shell frames	Suspect frame and each adjacent	At each end and mid-span: (a) 5 point pattern on both web and flange (b) 5 point pattern within 25 mm of welded attachment to both side shell and hopper sloping plate

Table 3.6.6 Thickness measurement - Single skin bulk carriers - Double bottom and hopper structure, with substantial corrosion

Structural member	Extent of measurement	Pattern of measurement
(1) Inner bottom plating	Suspect plate plus all immediately adjacent plates	5 point pattern for each panel between longitudinals over 1 m length
(2) Inner bottom longitudinals	Three longitudinals in way of plates measured	3 measurements in line across web and 3 measurements on flange
(3) Transverse floors and longitudinal girders	Suspect plates	5 point pattern over approximately 1 m ² of plating
(4) Watertight floors and girders	(a) lower 1/3 of tank (b) upper 2/3 of tank	(a) 5 point pattern over 1 m ² of plating (b) 5 point pattern alternate plates over 1 m ² of plating
(5) Transverse web frames	Suspect plate	5 point pattern over 1 m ² of plating

Table 3.6.7 Thickness measurement - Single and double skin bulk carriers - Transverse bulkheads in cargo holds, with substantial corrosion

Structural member	Extent of measurement	Pattern of measurement
(1) Lower stool	(a) Transverse band within 25 mm of welded connection to inner-bottom	(a) 5 point pattern between stiffeners over 1 m length
	(b) Transverse band within 25 mm of welded connection to shelf plate	(b) as above
(2) Transverse bulkhead	(a) Transverse band immediately above lower stool shelf plate	(a) 5 point pattern over 1 m length
	(b) Transverse band at approximately mid-height	(b) 5 point pattern over 1 m ² of plating
	(c) Transverse band at part of bulkhead adjacent to upper deck or below upper stool shelf plate (for those ships fitted with upper stools)	(c) 5 point pattern over 1 m ² of plating

Table 3.6.8 Thickness measurement - Single skin and double skin bulk carriers - Deck structure* with substantial corrosion

Structural member	Extent of measurement	Pattern of measurement
(1) Cross deck plating	Suspect cross deck strip plating	5 point pattern between underdeck stiffeners over 1 m length
(2) Underdeck stiffeners	(a) Transverse members	(a) 5 point pattern at each end and mid-span
	(b) Longitudinal member	(b) 5 point pattern on both web and flange
(3) Hatch covers	(a) Each side and end plate 3 locations	(a) 5 point pattern at each location
	(b) Hatch cover top plate, 3 longitudinal bands - 2 on outboard strakes and 1 on centreline strake	(b) 5 point measurement at each band
(4) Hatch coamings	Each side and end of coaming, one upper and one lower band	5 point measurement at each band
(5) Topside salt water ballast tanks	(a) Watertight transverse bulkheads	(i) 5 point pattern over 1 m ² of plating
	(i) lower 1/3 of bulkhead	(ii) 5 point pattern over 1 m ² of plating
	(ii) upper 2/3 of bulkhead	(iii) 5 point pattern over 1 m length
	(iii) stiffeners	
	(b) Swash transverse bulkheads	(i) 5 point pattern over 1 m ² of plating
	(i) lower 1/3 of bulkhead	(ii) 5 point pattern over 1 m ² of plating
	(ii) upper 2/3 of bulkhead	(iii) 5 point pattern over 1 m length
	(iii) stiffeners	
	(c) 3 representative bays of the topside sloping plate	(i) 5 point pattern over 1 m ² of plating
	(ii) 5 point pattern over 1 m ² of plating	
(i) lower 1/3 of tank		
(ii) upper 2/3 of tank		

Periodical Survey Regulations

Part 1, Chapter 3

Section 6

(6) Main deck plating	(d) suspect longitudinals and adjacent plates Suspect plates and 4 immediately adjacent plates	5 point pattern both web and flange over 1 m length 5 point pattern over 1m ² of plating
(7) Main deck longitudinals	Minimum of 3 longitudinals where plating measured	5 point pattern on both web and flange over 1 m length
(8) Web frames/transverses	Suspect plates	5 point pattern over 1m ² of plating
* including cross strips, main cargo hatchways, hatch covers, coamings and topside tanks		

Table 3.6.9 Thickness measurement - Double skin bulk carriers - Double side space structure (including wing void spaces of ore carriers), with substantial corrosion

Structural member	Extent of measurement	Pattern of measurement
(1) Bottom, inner bottom and hopper structure plating	(a) Minimum of 3 bays across double bottom tank, including aft bay (b) Measurements around and under all suction bell mouths	5 point pattern for each panel between longitudinals and floors
(2) Bottom, inner bottom and hopper structure longitudinals	Minimum of 3 longitudinals in each bay where bottom plating measured	3 measurements in line across flange and 3 measurements on the vertical web
(3) Bottom girders, including watertight girders	At fore and aft watertight floors and in centre of tanks	Vertical line of single measurements on girder plating with 1 measurement between each panel stiffener, or a minimum of 3 measurements
(4) Bottom floors, including watertight floors	3 floors in the bays where bottom plating measured, with measurements at both ends and middle	5 point pattern over 2 m ² area
(5) Hopper structure web frame ring	3 floors in bays where bottom plating measured	5 point pattern over 1 m ² of plating and single measurements on flange
(6) Hopper structure transverse watertight bulkhead or swash bulkhead	(a) lower 1/3 of bulkhead (b) upper 2/3 of bulkhead (c) stiffeners (minimum of 3)	(a) 5 point pattern over 1 m ² of plating (b) 5 point pattern over 2 m ² of plating (c) For web, 5 point pattern over span (2 measurements across web at each end and 1 at centre of span). For flange, single measurements at each end and centre of span
(7) Panel stiffening	Where applicable	Single measurements

Table 3.6.10 Thickness measurement - Double skin bulk carriers - Double side space structure (including wing void spaces of ore carriers), with substantial corrosion

Structural member	Extent of measurement	Pattern of measurement
(1) Side shell and inner plating:	(i) Plating between each pair of transverse frames/longitudinals in a minimum of 3 bays along the tank	(i) Single measurement
(i) Upper strake and strakes in way of horizontal girders	(ii) Plating between every third pair of longitudinals in same 3 bays	(ii) Single measurement
(ii) All other strakes		

(2) Side shell and inner side transverse frames/longitudinals on:	(i) Each transverse frame/longitudinal in same 3 bays	(i) 3 measurements across web and 1 measurement on flange
(i) Upper strake	(ii) Every third transverse frame/ longitudinal in same 3 bays	(ii) 3 measurements across web and 1 measurement on flange
(ii) All other strakes		
(3) Transverse frames/longitudinals - brackets	Minimum of 3 at top, middle and bottom of tank in same 3 bays	5 point pattern over area of bracket
(4) Vertical web and transverse bulkheads:	(i) Minimum of 2 webs and both transverse bulkheads	(i) 5 point pattern over approx. 2 m ² area
(i) Strakes in way of horizontal girders	(ii) Minimum of 2 webs and both transverse bulkheads	(ii) 2 measurements between each pair of vertical stiffeners
(ii) Other strakes		
(5) Horizontal girders	Plating on each girder in a minimum of 3 bays	2 measurements between each pair of longitudinal girder stiffeners
(6) Panel stiffening	Where applicable	Single measurements

■ *Section 7*

Special Survey - Oil tankers (including ore/oil ships and ore/bulk/oil ships) - Hull requirements

7.1 General

7.1.1 The requirements of *Pt 1, Ch 3, 2 Annual Surveys - Hull and machinery requirements, Pt 1, Ch 3, 4 Docking Surveys and In-water Surveys - Hull and machinery requirements* and *Pt 1, Ch 3, 5 Special Survey - General - Hull requirements* are to be complied with as applicable.

7.1.2 In order to maintain and/or assign the **ESP** notation, the following requirements apply to the surveys of the hull structure and piping systems in way of the cargo tanks/cargo holds, pump rooms, cofferdam, pipe tunnels, void spaces, double bottom tanks, etc. in way of the cargo tank area and all salt-water ballast tanks.

7.2 Documentation

7.2.1 The Owner is to obtain, supply and maintain documentation on board as follows:

- (a) A survey file comprising reports of structural surveys, thickness measurement and executive hull summary in accordance with the *2011 ESP Code – International Code on the Enhanced Programme of Inspections During Surveys of Bulk Carriers and Oil Tankers, 2011 – Resolution A.1049(27)*.
- (b) Supporting documentation consisting of:
 - (i) Main structural plans of cargo tanks/cargo holds and ballast tanks (for ships built in accordance with IACS Common Structural Rules (CSR), these plans are to include for each structural element, both the as-built and the renewal thickness. Any thickness for voluntary addition is also to be clearly indicated on the plans. The midship section plan to be supplied on board the ship is to include the minimum allowable hull girder sectional properties for the tank transverse section in all cargo tanks).
 - (ii) Previous repair history.
 - (iii) Cargo and ballast history.
 - (iv) Records of inspections by ship's personnel with reference to structural deterioration in general, leakages in bulkheads and piping and the condition of the corrosion prevention systems, if any.
 - (v) Extent of use of inert gas plant and tank cleaning procedures.
 - (vi) Any other information that may help to identify critical structural areas and/or suspect areas requiring inspection.
 - (vii) Survey Programme as required by *Pt 1, Ch 3, 7.3 Planning for survey*.

The complete documentation in *Pt 1, Ch 3, 7.2 Documentation 7.2.1* is to be readily available for examination by the Surveyor and should be used as a basis for survey.

7.2.2 The documentation is to be kept on board for the lifetime of the ship.

7.3 Planning for survey

7.3.1 A Survey Programme is to be submitted by the Owner and is to include the proposals for survey, including the means of providing access for Close-up Survey, thickness measurement and tank testing and should take account of the information detailed in *Pt 1, Ch 3, 7.2 Documentation 7.2.1*.

7.3.2 Prior to the development of the Survey Programme a Survey Planning Questionnaire is to be completed and submitted by the Owner, see *Pt 1, Ch 3, 1.6 Preparation for survey and means of access 1.6.15*.

7.4 Overall Survey

7.4.1 All cargo tanks/cargo holds, and salt-water ballast tanks including double bottom tanks, pump rooms, pipe tunnels, cofferdams and void spaces bounding cargo tanks/cargo holds, deck and outer hull are to be examined, and this examination is to be supplemented by Close-up Survey, thickness measurement and testing as applicable, to ensure that the structural integrity remains effective.

7.4.2 The examination is to be sufficient to ascertain substantial corrosion, significant deformation, fractures, damages or other structural deterioration and, if deemed necessary by the Surveyor, suitable non-destructive examination may be required.

7.4.3 Where substantial corrosion, as defined in *Pt 1, Ch 3, 1.5 Definitions*, is identified and is not rectified, this will be subject to re-examination at Annual and/or Intermediate Surveys. In the case of salt-water ballast tanks and combined tanks for the carriage of salt-water ballast and cargo oil, the examination will be required at Annual Survey and Intermediate Survey. In the case of cargo oil tanks the examination will be required at Intermediate Surveys.

7.4.4 All cargo piping on deck, including Crude Oil Washing (COW) piping, and cargo and ballast piping within those spaces indicated in *Pt 1, Ch 3, 7.4 Overall Survey 7.4.1* are to be examined and tested under working conditions to ensure that tightness and condition remain satisfactory. Special attention is to be given to ballast piping in cargo tanks and any cargo piping in ballast tanks and void spaces.

7.4.5 Where salt-water ballast tanks have been converted to void spaces the survey extent is to be based upon salt-water ballast tank requirements.

7.4.6 Where provided, in association with a corrosion control **CC** special features notation, as defined in the *Register Book*, the condition of the protective coating or corrosion prevention system of cargo tanks is to be examined.

7.4.7 The attachment to the structure and condition of anodes in tanks is to be examined.

7.4.8 Where fitted, the strums of the cargo suction pipes are to be removed or lifted to facilitate examination of the shell plating and bulkheads in the vicinity, unless other means for visual inspection of these parts are provided.

7.5 Testing

7.5.1 The minimum ballast tank testing requirements are given in *Table 3.7.1 Tank testing requirements - Single hull and double hull oil tankers, ore/oil ships and ore/bulk/oil ships* and, where required, the Surveyor may extend the tank testing if deemed necessary. The remaining requirements for tank testing, as applicable, are given in *Pt 1, Ch 3, 5.3 Examination and testing 5.3.5*.

7.5.2 The minimum cargo tank testing requirements are given in *Table 3.7.1*; boundaries of cargo tanks are to be tested to the highest point that liquid will rise to under service conditions.

Cargo tank testing carried out by the ship's crew under the direction of the Master may be accepted by the Surveyor provided the following conditions are complied with:

- (a) A tank testing procedure has been submitted by the Owner and reviewed by LR prior to the testing being carried out.
- (b) There is no record of leakage, distortion or substantial corrosion that would affect the structural integrity of the tank.
- (c) The tank testing has been satisfactorily carried out within the special survey window not more than 3 months prior to the date of the survey on which the overall or close-up survey is completed.
- (d) The satisfactory results of the testing are recorded in the ship's logbook.
- (e) The internal and external condition of the tanks and associated structure is found satisfactory by the Surveyor at the time of the overall and close-up survey.

Table 3.7.1 Tank testing requirements - Single hull and double hull oil tankers, ore/oil ships and ore/bulk/oil ships

Special Survey I (Ships 5 years old)	Special Survey II and subsequent (Ships 10 years old and over)
All ballast tank boundaries	All ballast tank boundaries
Cargo tank boundaries facing ballast tanks, void spaces, pipe tunnels, pump rooms or cofferdams	All cargo tank bulkheads

7.6 Close-up Survey

7.6.1 The minimum requirements for Close-up Survey are given in *Table 3.7.2 Close-up Survey - Single hull oil tankers* (Single hull oil tankers), *Table 3.7.3 Close-up Survey - Double hull oil tankers* (Double hull oil tankers), *Table 3.7.4 Close-up Survey - Ore/oil ships* (Ore/oil ships) and *Table 3.7.5 Close-up Survey - Ore/bulk/oil ships* (Ore/bulk/oil ships).

Table 3.7.2 Close-up Survey - Single hull oil tankers

Special Survey I (Ships 5 years old)	Special Survey II (Ships 10 years old)	Special Survey III (Ships 15 years old)	Special Survey IV (Ships 20 years old and over)
<p>(1) One web frame ring – in a wing ballast tank, if any, or a cargo wing tank used primarily for water ballast, see Note 1</p> <p>(2) One deck transverse – in a cargo tank, see Note 2</p> <p>(3) One transverse bulkhead, see Note 4:</p> <p>(a) in a ballast tank</p> <p>(b) in a cargo wing tank</p> <p>(c) in a cargo centre tank</p>	<p>(1) All web frame rings – in a wing ballast tank, if any, or a cargo wing tank used primarily for water ballast, see Note 1</p> <p>(2) One deck transverse, see Notes 2 and 8:</p> <p>(a) in each of the remaining ballast tanks, if any</p> <p>(b) in a cargo wing tank</p> <p>(c) in 2 cargo centre tanks</p> <p>(3) Both transverse bulkheads – in a wing ballast tank, if any, or a cargo wing tank used primarily for water ballast, see Note 3</p> <p>(4) One transverse bulkhead, see Note 4:</p> <p>(a) in each remaining ballast tank</p> <p>(b) in a cargo wing tank</p> <p>(c) in 2 cargo centre tanks</p>	<p>(1) All web frame rings, see Note 1:</p> <p>(a) in all ballast tanks</p> <p>(b) in a cargo wing tank</p> <p>(2) A minimum of 30% of all web frame rings in each remaining cargo wing tank, see Notes 1 and 8</p> <p>(3) All transverse bulkheads – in all cargo and ballast tanks, see Note 3</p> <p>(4) A minimum of 30% of deck and bottom transverses in each cargo centre tank, see Notes 5 and 8.</p> <p>(5) As considered necessary by Surveyor, see Note 6</p>	<p>(1) As Special Survey III</p> <p>(2) Additional transverse areas if deemed necessary by the Surveyor</p>
<p>Note 1. Complete transverse web frame ring including adjacent structural members.</p> <p>Note 2. Deck transverse including adjacent deck structural members.</p> <p>Note 3. Transverse bulkhead complete, including girder system and adjacent members, and adjacent longitudinal bulkhead structure.</p> <p>Note 4. Transverse bulkhead lower part including girder system and adjacent structural members.</p>		<p>Note 5. Deck and bottom transverse including adjacent structural members.</p> <p>Note 6. Additional complete transverse web frame ring.</p> <p>Note 7. Ballast tank includes peak tanks.</p> <p>Note 8. Within the mid 0,5 length of the tank. The 30% is to be rounded up to the next whole number of structural items.</p>	

Table 3.7.3 Close-up Survey - Double hull oil tankers

Special Survey I (Ships 5 years old)	Special Survey II (Ships 10 years old)	Special Survey III (Ships 15 years old)	Special Survey IV (Ships 20 years old and over)
<p>(1) One web frame ring in a complete ballast tank, see Notes 1 and 3</p> <p>(2) One deck transverse in a cargo tank, see Notes 4 and 12</p> <p>(3) One transverse bulkhead in a complete ballast tank, see Notes 1 and 6</p> <p>(4) One transverse bulkhead in a cargo centre tank, see Notes 2 and 7</p> <p>(5) One transverse bulkhead in a cargo wing tank, see Note 7</p>	<p>(1) All web frame rings in a complete ballast tank, see Notes 1 and 3</p> <p>(2) The knuckle area and the upper part (approx. 5 m) of one web frame ring in each remaining ballast tank, see Note 8</p> <p>(3) One deck transverse in two cargo tanks, see Note 4</p> <p>(4) One transverse bulkhead in each complete ballast tank, see Notes 1 and 6</p> <p>(5) One transverse bulkhead in two cargo centre tanks, see Notes 2 and 7</p> <p>(6) One transverse bulkhead in a cargo wing tank, see Note 7</p>	<p>(1) All web frame rings in all ballast tanks, see Note 3</p> <p>(2) All web frame rings in a cargo tank, see Note 9</p> <p>(3) One web frame ring in each remaining cargo tank, see Note 9</p> <p>(4) All transverse bulkheads— in all cargo and ballast tanks, see Notes 5 and 6</p> <p>(5) As considered necessary by the Surveyor, see Note 10</p>	<p>(1) As Special Survey III</p> <p>(2) Additional transverse areas if deemed necessary by the Surveyor, see Note 10</p>
<p>Note (1) Complete ballast tank means double bottom tank plus the double side tank and the double deck tank, as applicable, even if these are separate.</p> <p>Note (2) Where there are no centre tanks, the transverse bulkheads in wing tanks are to be subject to Close-up Survey.</p> <p>Note (3) Web frame ring in a ballast tank includes the vertical web in side tank, hopper web in hopper tank, floor in double bottom tank and deck transverse in a double deck tank and adjacent structural members. In peak tanks a web frame means a complete transverse web frame, including adjacent structural members.</p> <p>Note (4) Deck transverse including adjacent deck structural members (or external structure on deck in way of the tank, where applicable).</p> <p>Note (5) Transverse bulkhead complete in cargo tanks, including girder system, adjacent structural members (including longitudinal bulkheads) and internal structure of lower and upper stools, where fitted.</p>		<p>Note (6) Transverse bulkhead complete in ballast tanks, including girder system and adjacent structural members including longitudinal bulkheads, girders in double bottom tanks, inner bottom plating, hopper side, connecting brackets.</p> <p>Note (7) Transverse bulkhead lower part in cargo tanks, including girder system, adjacent structural members (including longitudinal bulkheads) and internal structure of lower stool, where fitted.</p> <p>Note (8) The knuckle area and the upper part (approximately 5 m), including adjacent structural members. Knuckle area is the area of the web frame around the connections of the sloping hopper plating to the inner hull bulkhead and the inner bottom plating, up to 2 m from the corners both on the bulkhead and the double bottom.</p> <p>Note (9) Web frame ring in cargo tank includes deck transverse, longitudinal bulkhead vertical girder and cross ties, where fitted, and adjacent structural members.</p> <p>Note (10) Additional complete transverse web frame ring.</p> <p>Note (11) Ballast tanks includes peak tanks.</p> <p>Note (12) Within the mid 0,5 length of the tank.</p>	

Periodical Survey Regulations

Part 1, Chapter 3 Section 7

Table 3.7.4 Close-up Survey - Ore/oil ships

Special Survey I (Ships 5 years old)	Special Survey II (Ships 10 years old)	Special Survey III (Ships 15 years old)	Special Survey IV (Ships 20 years old and over)
<p>(1) One web frame ring – in a wing ballast tank, if any, or a cargo wing tank used primarily for water ballast, see Note 1</p> <p>(2) One deck transverse – in a cargo tank, see Note 2</p> <p>(3) One transverse bulkhead, see Note 4:</p> <p>(a) in a ballast tank</p> <p>(b) in a cargo wing tank</p> <p>(c) in a cargo centre tank</p>	<p>(1) All web frame rings – in a wing ballast tank, if any, or a cargo wing tank used primarily for water ballast, see Note 1</p> <p>(2) One deck transverse, see Notes 2 and 6:</p> <p>(a) in each of the remaining ballast tanks, if any</p> <p>(b) in a cargo wing tank</p> <p>(c) in 2 cargo centre tanks</p> <p>(3) Both transverse bulkheads – in a wing ballast tank, if any, or a cargo wing tank used primarily for water ballast, see Note 3</p> <p>(4) One transverse bulkhead, see Note 4:</p> <p>(a) in each remaining ballast tank</p> <p>(b) in a cargo wing tank</p> <p>(c) in 2 cargo centre tanks</p> <p>(5) Selected cargo hold hatch covers and coamings (plating and stiffeners)</p> <p>(6) Selected areas of deck plating inside line of hatch openings between cargo hold hatches</p>	<p>(1) All web frame rings, see Note 1</p> <p>(a) in all ballast tanks</p> <p>(b) in a cargo wing tank</p> <p>(2) One web frame ring – in each remaining cargo wing tank, see Notes 1 and 6</p> <p>(3) One deck transverse - in each cargo centre tank, see Notes 2 and 6</p> <p>(4) All transverse bulkheads– in all cargo and ballast tanks, see Note 3</p> <p>(5) All cargo hold hatch covers and coamings (plating and stiffeners)</p> <p>(6) All deck plating inside line of hatch coamings between cargo hold hatches</p> <p>(7) As considered necessary by the Surveyor, see Note 5</p>	<p>(1) As Special Survey III</p> <p>(2) Additional transverse areas if deemed necessary by the Surveyor</p>
<p>Note 1. Complete transverse web frame ring including adjacent structural members.</p> <p>Note 2. Deck transverse including adjacent deck structural members.</p> <p>Note 3. Transverse bulkhead complete, including girder system and adjacent members, and adjacent longitudinal bulkhead structure.</p>		<p>Note 4. Transverse bulkhead lower part including girder system and adjacent structural members.</p> <p>Note 5. Additional complete transverse web frame ring.</p> <p>Note 6. Within the mid 0,5 length of the tank.</p>	

Table 3.7.5 Close-up Survey - Ore/bulk/oil ships

Special Survey I (Ships 5 years old)	Special Survey II (Ships 10 years old)	Special Survey III (Ships 15 years old)	Special Survey IV (Ships 20 years old and over)
<p>(1) 25% of shell frames and their end attachments in the forward cargo hold at representative positions</p> <p>(2) Selected frames and their end attachments in remaining cargo holds</p> <p>(3) 1 transverse web with associated plating and longitudinals in 2 representative water ballast tanks of each (i.e. topside, hopper side or side tank)</p> <p>(4) 2 selected cargo hold transverse bulkheads including internal structure of upper and lower stools where fitted. This is to include the aft bulkhead in the forward cargo hold</p>	<p>(1) 25% of shell frames including their end attachments and adjacent shell plating in all cargo holds</p> <p>(2) 1 transverse web with associated plating and longitudinals in each water ballast tank (i.e. topside, hopper side or side tank)</p> <p>(3) Forward and aft transverse bulkhead in 1 side ballast tank, including stiffening system</p> <p>(4) 1 transverse bulkhead in each cargo hold including internal structure of upper and lower stools where fitted. This is to include the aft bulkhead in the forward cargo hold</p> <p>(5) Selected cargo hold hatch covers and coamings (plating and stiffeners)</p> <p>(6) Selected areas of deck plating inside line of hatch openings between cargo hold hatches</p>	<p>(1) All shell frames in the forward cargo hold and 25% of frames in remaining cargo holds, including their end attachments and adjacent shell plating</p> <p>(2) All transverse webs with associated plating and longitudinals in each water ballast tank (i.e. topside, hopper side or side tank)</p> <p>(3) All transverse bulkheads in ballast tanks, including stiffening system</p> <p>(4) All cargo hold transverse bulkheads including internal structure of upper and lower stools, where fitted</p> <p>(5) All cargo hold hatch covers and coamings (plating and stiffeners)</p> <p>(6) All deck plating inside line of hatch openings between cargo hold hatches</p>	<p>(1) All shell frames including their end attachments and adjacent shell plating in all cargo holds</p> <p>(2) All transverse webs with associated plating and longitudinals in each water ballast tank (i.e. topside, hopper side or side tank)</p> <p>(3) All transverse bulkheads in ballast tanks, including stiffening system</p> <p>(4) All cargo hold transverse bulkheads including internal structure of upper and lower stools, where fitted</p> <p>(5) All cargo hold hatch covers and coamings (plating and stiffeners)</p> <p>(6) All deck plating inside line of hatch openings between cargo hold hatches</p>
<p>Note 1. Ballast tank includes peak tanks.</p> <p>Note 2. Close-up Survey of transverse bulkheads to be carried out at four levels:</p> <p>Note Level (a) Immediately above the inner bottom and immediately above the line of gussets (if fitted) and shedders for ships without lower stool.</p> <p>Note Level (b) Immediately above and below the lower stool shelf plate (for those ships fitted with lower stools), and immediately above the line of the shedder plates.</p> <p>Note Level (c) About mid-height of the bulkhead.</p> <p>Note Level (d) Immediately below the upper deck plating and immediately adjacent to the upper wing tank and immediately below the upper stool shelf plate for those ships fitted with upper stools, or immediately below the topside tanks.</p>			

7.6.2 The Surveyor may extend the Close-up Survey, if deemed necessary, taking into account the maintenance of the tanks under survey, the condition of the corrosion prevention system, and the following:

- (a) Structural arrangements or details which have suffered defects in similar spaces or on similar ships.
- (b) Spaces which have structures approved with reduced scantlings in association with an approved corrosion control system.

7.6.3 For areas in tanks where coatings are found to be in GOOD condition, as defined in *Pt 1, Ch 3, 1.5 Definitions*, the extent of Close-up Surveys may be specially considered.

7.7 Thickness measurement

7.7.1 The minimum requirements for thickness measurements are given in *Table 3.7.6 Thickness measurement - Single hull and double hull oil tankers, ore/oil ships and ore/bulk/oil ships* (Single and double hull oil tankers, including ore/oil ships and ore/bulk/oil ships), see also *Pt 1, Ch 3, 5.6 Thickness measurement*. For ships built in accordance with the IACS Common Structural Rules (CSR), refer to the LR document *Thickness Measurement and Close-Up Survey Guidance*.

Table 3.7.6 Thickness measurement - Single hull and double hull oil tankers, ore/oil ships and ore/bulk/oil ships

Special Survey I (Ships 5 years old)	Special Survey III (Ships 15 years old)	Special Survey IV (Ships 20 years old and over)
<p>(1) 1 section of deck plating for the full beam of the ship within 0.5L amidships in way of a ballast tank, if any, or a cargo tank used primarily for water ballast.</p> <p>(2) Measurements for general assessment and recording of corrosion pattern of the structural members subject to Close-up Survey in accordance with <i>Table 3.7.2 Close-up Survey - Single hull oil tankers, Table 3.7.3 Close-up Survey - Double hull oil tankers, Table 3.7.4 Close-up Survey - Ore/oil ships or Table 3.7.5 Close-up Survey - Ore/bulk/oil ships</i>.</p> <p>(3) Critical areas, as required by the Surveyor.</p>	<p>(1) Within the cargo area.</p> <p>(a) Each deck plate.</p> <p>(b) 2 transverse sections, see Note 6.</p> <p>(2) Measurements for general assessment and recording of corrosion pattern of the structural members subject to Close-up Survey in accordance with <i>Table 3.7.2 Close-up Survey - Single hull oil tankers, Table 3.7.3 Close-up Survey - Double hull oil tankers, Table 3.7.4 Close-up Survey - Ore/oil ships or Table 3.7.5 Close-up Survey - Ore/bulk/oil ships</i>.</p>	<p>(1) Within the cargo area:</p> <p>(a) Each deck plate.</p> <p>(b) 3 transverse sections, see Note 6.</p> <p>(c) Each bottom plate.</p> <p>(2) Measurements for general assessment and recording of corrosion pattern of the structural members subject to Close-up Survey in accordance with <i>Table 3.7.2 Close-up Survey - Single hull oil tankers, Table 3.7.3 Close-up Survey - Double hull oil tankers, Table 3.7.4 Close-up Survey - Ore/oil ships or Table 3.7.5 Close-up Survey - Ore/bulk/oil ships</i>.</p>
<p>Special Survey II (Ships 10 years old)</p>	<p>(3) Selected wind and water strakes outside the cargo area.</p>	<p>(3) All wind and water strakes over the full length of the ship, port and starboard.</p>
<p>(1) Within the cargo tank area:</p> <p>(a) Each deck plate.</p> <p>(b) 1 transverse section, see Note 6.</p> <p>(2) Measurements for general assessment and recording of corrosion pattern of the structural members subject to Close-up Survey in accordance with <i>Table 3.7.2 Close-up Survey - Single hull oil tankers, Table 3.7.3 Close-up Survey - Double hull oil tankers, Table 3.7.4 Close-up Survey - Ore/oil ships or Table 3.7.5 Close-up Survey - Ore/bulk/oil ships</i>.</p> <p>(3) Selected wind and water strakes outside the cargo area.</p> <p>(4) Critical areas, as required by the Surveyor.</p>	<p>(4) All wind and water strakes within the cargo area.</p> <p>(5) All cargo hold hatch covers and coamings (plating and stiffeners), see Note 5.</p> <p>(6) All transverse webs with associated plating and longitudinals, and the transverse bulkhead complete in the fore peak tank and aft peak tank, see Notes 1 and 4</p> <p>(7) Critical areas, as required by the Surveyor.</p>	<p>(4) All cargo hold hatch covers and coamings (plating and stiffeners), see Note 5.</p> <p>(5) Remaining exposed main deck plating not considered in item (1) and representative exposed superstructure deck plating (i.e. poop, bridge and fore-castle deck).</p> <p>(6) All transverse webs with associated plating and longitudinals, and the transverse bulkhead complete in the fore peak tank and aft peak tank, see Notes 1 and 4.</p> <p>(7) All keel plates outside the cargo tank length. Also additional bottom plates in way of cofferdams, Machinery space and aft end of tanks.</p> <p>(8) Plating of seachests. Also side shell plating in way of overboard discharges, as considered necessary by the Surveyor.</p> <p>(9) Critical areas, as required by the Surveyor.</p>

Note 1. For areas in tanks where coatings are found to be in GOOD condition, as defined in *Pt 1, Ch 3, 1.5 Definitions*, the extent of thickness measurements may be specially considered, but not dispensed with in its entirety.

Note 2. Transverse sections should be chosen where the largest reductions are likely to occur, or as revealed by deck plating measurement.

Note 3. Where two or three transverse sections are required to be measured, at least one is to include a ballast tank within 0,5L amidships.

Note 4. Transverse bulkhead complete including stiffening system.

Note 5. All cargo hold hatch covers and coamings, where fitted, are to be measured on ore/oil and ore/bulk/oil ships.

Note 6. For oil tankers (including ore/oil and ore/bulk/oil ships), with length ≥ 130 m and over 10 years of age, the longitudinal strength is to be evaluated. In such cases, a minimum of three transverse sections are to be measured within 0,5L amidships.

7.7.2 In areas where substantial corrosion, as defined in *Pt 1, Ch 3, 1.5 Definitions*, has been noted then additional measurements are to be carried out, as applicable, in accordance with *Table 3.7.7 Thickness measurement - Single hull oil tankers, ore/oil ships and ore/bulk/oil ships - Bottom structure with substantial corrosion*, *Table 3.7.8 Thickness measurement - Single hull oil tankers, ore/oil ships and ore/bulk/oil ships - Deck structure with substantial corrosion*, *Table 3.7.9 Thickness measurement - Single hull oil tankers, ore/oil ships and ore/bulk/oil ships - Shell and longitudinal bulkheads with substantial corrosion*, *Table 3.7.9 Thickness measurement - Single hull oil tankers, ore/oil ships and ore/bulk/oil ships - Shell and longitudinal bulkheads with substantial corrosion*, *Table 3.7.11 Thickness measurement - Double hull oil tankers - Bottom, inner bottom and hopper structure with substantial corrosion*, *Table 3.7.12 Thickness measurement - Double hull oil tankers - Deck structure with substantial corrosion*, *Table 3.7.13 Thickness measurement - Double hull oil tankers - Wing ballast tank structure with substantial corrosion*, *Table 3.7.14 Thickness measurement - Double hull oil tankers - Longitudinal bulkhead structure in cargo tanks with substantial corrosion* and *Table 3.7.15 Thickness measurement - Double hull oil tankers - Transverse watertight and swash bulkhead structure in cargo tanks with substantial corrosion* to determine the full extent of the corrosion pattern. The survey will not be considered complete until these additional thickness measurements have been carried out. For double hull oil tankers built in accordance with the IACS Common Structural Rules (CSR), the identified substantial corrosion areas are required to be examined and additional thickness measurements are to be carried out at Annual and Intermediate Surveys.

7.7.3 For **oil tankers** (including ore/oil and ore/bulk/oil ships) of 130 m in length and upwards (as defined by the *International Convention on Load Lines* in force), the ship's longitudinal strength is to be evaluated by using the thickness of structural members measured, renewed and reinforced as appropriate, during the Special Surveys carried out after the ship reaches 10 years of age.

7.7.4 Steel renewal evaluation of hatch covers and hatch coamings of cargo holds on combination carriers with contract for construction on or after 1 January 2004 is to be in accordance with IACS UR S21. These requirements are not applicable to ships built in accordance with the IACS Common Structural Rules (CSR). Further information is provided in the LR document *Thickness Measurement and Close-Up Survey Guidance*.

7.7.5 Steel renewal is required where the gauged thickness is less than $t_{net} + 0,5$ mm. For definition of t_{net} , see *Pt 4, Ch 7, 12.1 General 12.1.2*.

7.7.6 Where the gauged thickness is within the range $t_{net} + 0,5$ mm and $t_{net} + 1,0$ mm, a coating (applied in accordance with coating manufacturer's requirements) or annual gauging may be adopted as an alternative to steel renewal.

Table 3.7.7 Thickness measurement - Single hull oil tankers, ore/oil ships and ore/bulk/oil ships - Bottom structure with substantial corrosion

Structural member	Extent of measurement	Pattern of measurement
(1) Bottom plating	Minimum of 3 bays across tank, including aft bay Measurement around and under all suction strums	5 point pattern for each panel between longitudinals and webs
(2) Bottom longitudinals	Minimum of 3 longitudinals in each bay where bottom plating measured	3 measurements in line across flange and 3 measurements on vertical web
(3) Bottom girders and brackets	At fore and aft transverse bulkhead, bracket toes and in centre of tanks	Vertical line of single measurements on web plating with 1 measurement between each panel stiffener, or a minimum of 3 measurements. 2 measurements across face flat. 5 point pattern on girder/bulkhead brackets

(4) Bottom transverse webs	3 webs in bays where bottom plating measured, with measurements at middle and both ends	5 point pattern over 2 m ² area. Single measurements on face flat
(5) Panel stiffening	Where applicable	Single measurements

Table 3.7.8 Thickness measurement - Single hull oil tankers, ore/oil ships and ore/bulk/oil ships - Deck structure with substantial corrosion

Structural member	Extent of measurement	Pattern of measurement
(1) Deck plating	2 bands across tank	Minimum of 3 measurements per plate per band
(2) Deck longitudinals	Minimum of 3 longitudinals in each of 2 bays	3 measurements in line vertically on webs and 2 measurements on flange (if fitted)
(3) Deck girders and brackets	At fore and aft transverse bulkhead, bracket toes and in centre of tanks	Vertical line of single measurements on web plating with 1 measurement between each panel stiffener, or a minimum of 3 measurements. 2 measurements across face flat. 5 point pattern on girder/bulkhead brackets
(4) Deck transverse webs	Minimum of 2 webs with measurement at both ends and middle of span	5 point pattern over 2 m ² area. Single measurements on face flat
(5) Panel stiffening	Where applicable	Single measurements

Table 3.7.9 Thickness measurement - Single hull oil tankers, ore/oil ships and ore/bulk/oil ships - Shell and longitudinal bulkheads with substantial corrosion

Structural member	Extent of measurement	Pattern of measurement
(1) Deckhead and bottom strakes and strakes in way of stringer platforms	Plating between each pair of longitudinals in a minimum of 3 bays	Single measurement
(2) All other strakes	Plating between every 3rd pair of longitudinals in same 3 bays	Single measurement
(3) Longitudinals – deckhead and bottom strakes	Each longitudinal in same 3 bays	3 measurements across web and 1 measurement on flange
(4) Longitudinals – all others	Every third longitudinal in same 3 bays	3 measurements across web and 1 measurement on flange
(5) Longitudinals – bracket	Minimum of 3 at top, middle and bottom of tank in same 3 bays	5 point pattern over area of bracket
(6) Web frames and cross ties	3 webs with minimum of 3 locations on each web, including in way of cross tie connections	5 point pattern over 2 m ² area, plus single measurements on web frame and cross tie face flats

Table 3.7.10 Thickness measurement - Single hull oil tankers, ore/oil ships and ore/bulk/oil ships - Transverse bulkheads and swash bulkheads with substantial corrosion

Structural member	Extent of measurement	Pattern of measurement
(1) Deckhead and bottom strakes in way of stringer platforms	Plating between pair of stiffeners at 3 locations: approx. 1/4, 1/2 and 3/4 width of tank	5 point pattern between stiffeners over 1 m length

Periodical Survey Regulations

Part 1, Chapter 3

Section 7

(2) All other strakes	Plating between pair of stiffeners at middle location	Single measurement
(3) Strakes in corrugated bulkheads	Plating for each change of scantling at centre of panel and at flange or fabricated connection	5 point pattern over 1 m ² of plating
(4) Stiffeners	Minimum of 3 typical stiffeners	For web, 5 point pattern over span between bracket connections (2 measurements across web at each bracket connection and one at centre of span). For flange, single measurements at each bracket toe and at centre of span
(5) Brackets	Minimum of 3 at top, middle and bottom of tank	5 point pattern over area of bracket
(6) Deep webs and girders	Measurements at toe of bracket and at centre of span	For web, 5 point pattern over 1 m ² area. 3 measurements across face flat
(7) Stringer platforms	All stringers with measurements at middle and both ends	5 point pattern over 1 m ² area plus single measurements near bracket toes and on face flats

Table 3.7.11 Thickness measurement - Double hull oil tankers - Bottom, inner bottom and hopper structure with substantial corrosion

Structural member	Extent of measurement	Pattern of measurement
(1) Bottom, inner bottom and hopper plating	Minimum of 3 bays across double bottom tank, including aft bay. Measurement around and under all suction strums	5 point pattern for each panel between longitudinals and floors
(2) Bottom, inner bottom and hopper longitudinals	Minimum of 3 longitudinals in each bay where bottom plating measured	3 measurements in line across flange and 3 measurements on vertical web
(3) Bottom girders, including watertight girders	At the fore and aft watertight floors and in centre of tanks	Vertical line of single measurements on girder plating with 1 measurement between each panel stiffener, or a minimum of 3 measurements
(4) Bottom floors, including watertight floors	3 floors in bays where bottom plating measured, with measurements at both ends and middle	5 point pattern over 2 m ² area
(5) Hopper web frame ring	3 floors in bays where bottom plating measured	5 point pattern over 1 m ² of plating. Single measurements on flange
(6) Hopper transverse watertight bulkhead or swash bulkhead	(i) Lower $\frac{1}{3}$ of bulkhead (ii) Upper $\frac{2}{3}$ of bulkhead (iii) Stiffeners (minimum of 3)	(i) 5 point pattern over 1 m ² of plating. (ii) 5 point pattern over 2 m ² of plating. (iii) For web, 5 point pattern over span (2 measurements across web at each end and 1 at centre of span). For flange, single measurement at each end and centre of span.
(7) Panel stiffening	Where applicable	Single measurements

Table 3.7.12 Thickness measurement - Double hull oil tankers - Deck structure with substantial corrosion

Structural member	Extent of measurement	Pattern of measurement
(1) Deck plating	2 transverse bands across tank	Minimum of 3 measurements per plate per band
(2) Deck longitudinals	Every 3rd longitudinal in each of 2 bands with a minimum of 1 longitudinal	3 measurements in line vertically on webs and 2 measurements on flange (if fitted)
(3) Deck girders and brackets (usually in cargo tanks only)	At the fore and aft transverse bulkhead, bracket toes and in centre of tanks	Vertical line of single measurements on web plating with 1 measurement between each panel stiffener, or a minimum of 3 measurements. 2 measurements across flange. 5 point pattern on girder / bulkhead brackets
(4) Deck transverse webs	Minimum of 2 webs, with measurements at both ends and middle of span	5 point pattern over 1 m ² area. Single measurements on the flange
(5) Vertical web and transverse bulkhead in wing ballast tank (two metres from deck)	Minimum of 2 webs, and both transverse bulkheads	5 point pattern over 1 m ² area
(6) Panel stiffening	Where applicable	Single measurements

Table 3.7.13 Thickness measurement - Double hull oil tankers - Wing ballast tank structure with substantial corrosion

Structural member	Extent of measurement	Pattern of measurement
(1) Side shell and longitudinal bulkhead plating:	(i) Plating between each pair of longitudinals in a minimum of 3 bays (along the tank)	(i) Single measurements
(i) Upper strake and strakes in way of horizontal girders	(ii) Plating between every 3rd pair of longitudinals on same 3 bays	(ii) Single measurements
(ii) All other strakes		
(2) Side shell and longitudinal bulkhead longitudinals on:	(i) Each longitudinal in same 3 bays	(i) 3 measurements across web and 1 measurement on flange
(i) Upper strake	(ii) Every 3rd longitudinal in same 3 bays	(ii) 3 measurements across web and 1 measurement on flange
(ii) All other strakes		
(3) Longitudinals – brackets	Minimum of 3 at top, middle and bottom of tank in same 3 bays	5 point pattern over area of bracket
(4) Vertical web and transverse bulkheads (excluding deckhead area):	(i) Minimum of 2 webs and both transverse bulkheads	(i) 5 point pattern over approximately 2 m ² area
(i) Strakes in way of horizontal girders	(ii) Minimum of 2 webs and both transverse bulkheads	(ii) 2 measurements between each pair of vertical stiffeners
(ii) Other strakes		
(5) Horizontal girders	Plating on each girder in a minimum of 3 bays	2 measurements between each pair of longitudinal girder stiffeners
(6) Panel stiffening	Where applicable	Single measurements

Table 3.7.14 Thickness measurement - Double hull oil tankers - Longitudinal bulkhead structure in cargo tanks with substantial corrosion

Structural member	Extent of measurement	Pattern of measurement
(1) Deckhead and bottom strakes, and strakes in way of horizontal stringers on transverse bulkheads	Plating between each pair of longitudinals in a minimum of 3 bays	Single measurement
(2) All other strakes	Plating between every 3rd pair of longitudinals in same 3 bays	Single measurement
(3) Longitudinals on deckhead and bottom strakes	Each longitudinal in same 3 bays	3 measurements across web and 1 measurements on flange
(4) All other longitudinals	Every 3rd longitudinal in same 3 bays	3 measurements across web and 1 measurements on flange
(5) Longitudinals – brackets	Minimum of 3 at top, middle and bottom of tank in same 3 bays	5 point pattern over area of bracket
(6) Web frames and cross ties	3 webs with minimum of 3 locations on each web, including in way of cross tie connections	5 point pattern over approximately 2 m ² area of webs, plus single measurements on flanges of web frames and cross ties
(7) Lower end brackets (opposite side of web frame)	Minimum of 3 brackets	5 point pattern over approximately 2 m ² area of brackets, plus single measurements on bracket flanges

Table 3.7.15 Thickness measurement - Double hull oil tankers - Transverse watertight and swash bulkhead structure in cargo tanks with substantial corrosion

Structural member	Extent of measurement	Pattern of measurements
(1) Upper and lower stool, where fitted	Transverse band within 25 mm of welded connection to inner bottom/deck plating Transverse band within 25 mm of welded connection to shelf plate	5 point pattern between stiffeners over 1 m length
(2) Deckhead and bottom strakes, and strakes in way of horizontal stringers	Plating between pair of stiffeners at 3 locations; approximately ¼, ½ and ¾ width of tank.	5 point pattern between stiffeners over 1 m length
(3) All other strakes	Plating between pair of stiffeners at middle location	Single measurement
(4) Strakes in corrugated bulkheads	Plating for each change of scantling at centre of panel and at flange of fabricated connection	5 point pattern over approximately 1 m ² of plating
(5) Stiffeners	Minimum of 3 typical stiffeners	For web, 5 point pattern over span between bracket connections (2 measurements across web at each bracket connection and 1 at centre of span). For flange, single measurement at bracket toe and at centre of span
(6) Brackets	Minimum of 3 at top, middle and bottom of tank	5 point pattern over area of bracket
(7) Horizontal stringers	All stringers with measurements at both ends and middle	5 point pattern over 1 m ² area, plus single measurements near bracket toes and on flanges

■ Section 8

Special Survey - Chemical Tankers - Hull requirements

8.1 General

8.1.1 The requirements of *Pt 1, Ch 3, 2 Annual Surveys - Hull and machinery requirements*, *Pt 1, Ch 3, 4 Docking Surveys and In-water Surveys - Hull and machinery requirements* and *Pt 1, Ch 3, 5 Special Survey - General - Hull requirements* are to be complied with as applicable.

8.1.2 In order to maintain and/or assign the **ESP** notation, the following requirements apply to the surveys of the hull structure and piping systems in way of the cargo tanks, pump rooms, cofferdam, pipe tunnels, void spaces, double bottom tanks, etc. in way of the cargo tank area and all salt-water ballast tanks.

8.2 Documentation

8.2.1 The Owner is to obtain, supply and maintain documentation on board as follows:

- (a) A survey file comprising reports of structural surveys, thickness measurement and executive hull summary in accordance with the *2011 ESP Code – International Code on the Enhanced Programme of Inspections During Surveys of Bulk Carriers and Oil Tankers, 2011 – Resolution A.1049(27)*.
- (b) Supporting documentation consisting of:
 - (i) Main structural plans of cargo tanks and ballast tanks.
 - (ii) Previous repair history.
 - (iii) Cargo and ballast history.
 - (iv) Records of inspections by ship's personnel with reference to structural deterioration in general, leakages in bulkheads and piping and the condition of the corrosion prevention systems, if any.
 - (v) Extent of use of inert gas plant and tank cleaning procedures.
 - (vi) Any other information that may help to identify critical structural areas and/or suspect areas requiring inspection.
 - (vii) Survey Programme as required by *Pt 1, Ch 3, 8.3 Planning for survey*.

The complete documentation in *Pt 1, Ch 3, 8.2 Documentation 8.2.1* is to be readily available for examination by the Surveyor and should be used as a basis for survey.

8.2.2 The documentation is to be kept on board for the lifetime of the ship.

8.3 Planning for survey

8.3.1 A Survey Programme is to be submitted by the Owner and is to include the proposals for survey, including the means of providing access for Close-up Survey, thickness measurement, tank testing and should take account of the information detailed in *Pt 1, Ch 3, 8.2 Documentation 8.2.1*.

8.3.2 Prior to the development of the Survey Programme a Survey Planning Questionnaire is to be completed and submitted by the Owner, see *Pt 1, Ch 3, 1.6 Preparation for survey and means of access 1.6.15*.

8.4 Overall Survey

8.4.1 All cargo tanks and salt-water ballast tanks including double bottom tanks, pump rooms, pipe tunnels, cofferdams and void spaces bounding cargo tanks, deck and outer hull are to be examined, and this examination is to be supplemented by Close-up Survey, thickness measurement and testing as applicable, to ensure that the structural integrity remains effective.

8.4.2 The examination is to be sufficient to ascertain substantial corrosion, significant deformation, fractures, damages or other structural deterioration and, if deemed necessary by the Surveyor, suitable non-destructive examination may be required.

8.4.3 Where substantial corrosion, as defined in *Pt 1, Ch 3, 1.5 Definitions*, is identified and is not rectified, this will be subject to re-examination at Annual and/or Intermediate Surveys. In the case of salt-water ballast tanks the examination will be required at Annual Survey and Intermediate Survey. In the case of cargo tanks the examination will be required at Intermediate Surveys.

8.4.4 All cargo piping on deck, and cargo and ballast piping, within those spaces indicated in *Pt 1, Ch 3, 8.4 Overall Survey 8.4.1* are to be examined and tested under working conditions to ensure that tightness and condition remain satisfactory. Special attention is to be given to ballast piping in cargo tanks and any cargo piping in ballast tanks and void spaces.

8.4.5 The survey of stainless steel tanks may be carried out as an Overall Survey supplemented by Close-up Survey as deemed necessary by the Surveyor.

8.4.6 Where salt-water ballast tanks have been converted to void spaces the survey extent is to be based upon salt-water ballast tank requirements.

8.4.7 Where provided, in association with a corrosion control **CC** special features notation, as defined in the *Register Book*, the condition of the protective coating or corrosion prevention system of cargo tanks is to be examined.

8.4.8 The attachment to the structure and condition of anodes in tanks is to be examined.

8.4.9 Where fitted, the strums of the cargo suction pipes are to be removed or lifted to facilitate examination of the shell plating and bulkheads in the vicinity, unless other means for visual inspection of these parts are provided.

8.5 Testing

8.5.1 The minimum ballast tank testing requirements are given in *Table 3.8.1 Tank testing requirements - Chemical tankers* and, where required, the Surveyor may extend the tank testing if deemed necessary. Other arrangements for cargo tank testing will be considered on application. The remaining requirements for tank testing, as applicable, are given in *Pt 1, Ch 3, 5.3 Examination and testing 5.3.5*.

8.5.2 The minimum cargo tank testing requirements are given in *Table 3.8.1*, boundaries of cargo tanks are to be tested to the highest point that liquid will rise to under service conditions. Other arrangements for cargo tank testing will be considered on application.

Cargo tank testing carried out by the ship’s crew under the direction of the Master may be accepted by the Surveyor provided the following conditions are complied with:

- (a) A tank testing procedure has been submitted by the Owner and reviewed by LR prior to the testing being carried out.
- (b) There is no record of leakage, distortion or substantial corrosion that would affect the structural integrity of the tank.
- (c) The tank testing has been satisfactorily carried out within the special survey window not more than 3 months prior to the date of the survey on which the overall or close-up survey is completed.
- (d) The satisfactory results of the testing are recorded in the ship’s logbook.
- (e) The internal and external condition of the tanks and associated structure is found satisfactory by the Surveyor at the time of the overall and close-up survey.

Table 3.8.1 Tank testing requirements - Chemical tankers

Special Survey I (Ships 5 years old)	Special Survey II and subsequent (Ships 10 years old and over)
All ballast tank boundaries	All ballast tank boundaries
Cargo tank boundaries facing ballast tanks, void spaces, pipe tunnels, pump rooms or cofferdams	All cargo tank bulkheads

8.6 Close-up Survey

8.6.1 The minimum requirements for Close-up Survey are given in *Table 3.8.2 Close-up Survey - Single hull chemical tankers* (Single hull chemical tankers) and *Table 3.8.3 Close-up Survey - Double hull chemical tankers* (Double hull chemical tankers).

Table 3.8.2 Close-up Survey - Single hull chemical tankers

Special Survey I (Ships 5 years old)	Special Survey II (Ships 10 years old)	Special Survey III (Ships 15 years old)	Special Survey IV (Ships 20 years old and over)
<p>(1) One web frame ring in a ballast wing tank, see Note 1</p> <p>(2) One deck transverse in a cargo tank or on deck, see Note 2</p> <p>(3) One transverse bulkhead in a ballast tank, see Note 3</p> <p>(4) One transverse bulkhead in a cargo wing tank, see Note 3</p> <p>(5) One transverse bulkhead in a cargo centre tank, see Notes 3 and 5</p>	<p>(1) All web frame rings in a ballast wing tank or double bottom ballast tank, see Note 1</p> <p>(2) One deck transverse in each remaining ballast tank or on deck, see Note 2</p> <p>(3) One deck transverse in a cargo wing tank or on deck, see Note 2</p> <p>(4) One deck transverse in two cargo centre tanks or on deck, see Note 2</p> <p>(5) Both transverse bulkheads in a ballast wing tank, see Note 4</p> <p>(6) One transverse bulkhead in remaining ballast tank, see Note 3</p> <p>(7) One transverse bulkhead in a cargo wing tank, see Note 3</p> <p>(8) One transverse bulkhead in two cargo centre tanks, see Notes 3 and 5</p>	<p>(1) All web frame rings in all ballast tanks, see Note 1</p> <p>(2) All web frame rings in a cargo wing tank, see Note 1</p> <p>(3) One web frame ring in each remaining cargo tank, see Note 1</p> <p>(4) All transverse bulkheads – in all cargo and ballast tanks, see Notes 4</p>	<p>(1) As Special Survey III</p> <p>(2) Additional transverse areas if deemed necessary by the Surveyor</p>

Note 1. Complete transverse web frame ring including adjacent structural members.

Note 2. Deck transverse including adjacent deck structural members (or external structure on deck in way of the tank).

Note 3. Transverse bulkhead lower part including girder system and adjacent structural members.

Note 4. Transverse bulkhead complete, including girder system and adjacent members, and adjacent longitudinal bulkhead structure.

Note 5. Where there are no centre tanks, the transverse bulkheads in wing tanks are to be subject to Close-up Survey.

Note 6. Ballast tank includes peak tanks.

Table 3.8.3 Close-up Survey - Double hull chemical tankers

Special Survey I (Ships 5 years old)	Special Survey II (Ships 10 years old)	Special Survey III (Ships 15 years old)	Special Survey IV (Ships 20 years old and over)
(1) One web frame ring in a ballast double hull tank, see Notes 1 and 9	(1) All web frame rings in a ballast wing tank or ballast double hull tank, see Notes 1 and 9	(1) All web frame rings in all ballast tanks, see Note 1	(1) As Special Survey III
(2) One deck transverse in a cargo tank or on deck, see Note 2	(2) The knuckle area and the upper part (approx. 3 m) of one web frame ring in each remaining ballast tank, see Note 6	(2) All web frame rings in a cargo wing tank, see Note 7	(2) Additional transverse areas if deemed necessary by the Surveyor
(3) One transverse bulkhead in a ballast tank, see Note 5	(3) One deck transverse in two cargo tanks, see Note 2	(3) One web frame ring in each remaining cargo tank, see Note 7	
(4) One transverse bulkhead in a cargo wing tank, see Note 3	(4) One transverse bulkhead in each ballast tank, see Note 5	(4) All transverse bulkheads – in all cargo and ballast tanks, see Note 4 and 5	
(5) One transverse bulkhead in a cargo centre tank, see Notes 3 and 8	(5) One transverse bulkhead in a cargo wing tank, see Note 3 (6) One transverse bulkhead in two cargo centre tanks, see Notes 3 and 8		

Note 1. Web frame ring in a ballast tank includes the vertical web in side tank, hopper web in hopper tank, floor in double bottom tank and deck transverse in a double deck tank (where fitted) and adjacent structural members. In peak tanks, a web frame means a complete transverse web frame ring, including adjacent structural members.

Note 2. Deck transverse including adjacent deck structural members (or external structure on deck in way of the tank), where applicable.

Note 3. Transverse bulkhead lower part in cargo tanks, including girder system and adjacent structural members (including longitudinal bulkheads) and internal structure of lower stools, where fitted.

Note 4. Transverse bulkhead complete in cargo tanks, including girder system, adjacent structural members (including longitudinal bulkheads) and internal structure of lower and upper stools, where fitted.

Note 5. Transverse bulkhead complete in ballast tanks, including girder system and adjacent structural members including longitudinal bulkheads, girders in double bottom tanks, inner bottom plating, hopper side, connecting brackets.

Note 6. The knuckle area and the upper part (approximately 3 m), including adjacent structural members. Knuckle area is the area of the web frame around the connections of the sloping hopper plating to the inner hull bulkhead and the inner bottom plating, up to 2 m from the corners both on the bulkhead and the double bottom.

Note 7. Web frame ring in a cargo tank includes deck transverse, longitudinal bulkhead vertical girder and cross ties, where fitted, and adjacent structural members.

Note 8. Where there are no centre tanks, the transverse bulkheads in wing tanks are to be subject to Close-up Survey.

Note 9. Double hull tank includes double bottom and side tank even though these tanks may be separate.

Note 10. Ballast tank includes peak tanks.

8.6.2 The Surveyor may extend the Close-up Survey, if deemed necessary, taking into account the maintenance of the tanks under survey, the condition of the corrosion prevention system, and the following:

- (a) Structural arrangements or details which have suffered defects in similar spaces or on similar ships.
- (b) Spaces which have structures approved with reduced scantlings in association with an approved corrosion control system.

8.6.3 For areas in tanks where coatings are found to be in GOOD condition, as defined in *Pt 1, Ch 3, 1.5 Definitions*, the extent of Close-up Surveys may be specially considered.

8.7 Thickness measurement

8.7.1 The minimum requirements for thickness measurements are given in *Table 3.8.4 Thickness measurement - Single and double hull chemical tankers*, see also *Pt 1, Ch 3, 5.6 Thickness measurement*.

Table 3.8.4 Thickness measurement - Single and double hull chemical tankers

Special Survey I (Ships 5 years old)	Special Survey III (Ships 15 years old)	Special Survey IV (Ships 20 years old and over)
<p>(1) 1 section of deck plating for the full beam of the ship within 0,5L amidships (in way of a ballast tank, if any)</p> <p>(2) Measurements for general assessment and recording of corrosion pattern of the structural members subject to Close-up Survey in accordance with <i>Table 3.8.3 Close-up Survey - Double hull chemical tankers</i></p> <p>(3) Critical areas, as required by the Surveyor</p>	<p>(1) Within the cargo area:</p> <p>(a) Each deck plate</p> <p>(b) 2 transverse sections</p> <p>(2) Measurements for general assessment and recording of corrosion pattern of the structural members subject to Close-up Survey in accordance with <i>Table 3.8.3 Close-up Survey - Double hull chemical tankers</i></p> <p>(3) Selected wind and water strakes outside the cargo area</p>	<p>(1) Within the cargo area:</p> <p>(a) Each deck plate</p> <p>(b) 3 transverse sections</p> <p>(c) Each bottom plate</p> <p>(2) Measurements for general assessment and recording of corrosion pattern of the structural members subject to Close-up Survey in accordance with <i>Table 3.8.3 Close-up Survey - Double hull chemical tankers</i></p>
<p>Special Survey II (Ships 10 years old)</p>	<p>(4) All wind and water strakes within the cargo area</p>	<p>(3) All wind and water strakes over the full length of the ship, port and starboard</p>
<p>(1) Within the cargo area:</p> <p>(a) Each deck plate</p> <p>(b) 1 transverse section</p> <p>(2) Measurements for general assessment and recording of corrosion pattern of the structural members subject to Close-up Survey in accordance with <i>Table 3.8.3 Close-up Survey - Double hull chemical tankers</i></p> <p>(3) Selected wind and water strakes outside the cargo area</p> <p>(4) Critical areas, as required by the Surveyor</p>	<p>(5) All transverse webs with associated plating and longitudinals, and the transverse bulkhead complete in the fore peak tank and aft peak tank, see Notes 1 and 4</p> <p>(6) Critical areas, as required by the Surveyor</p>	<p>(4) Remaining exposed main deck plating not considered in item (1) and representative exposed superstructure deck plating (i.e. poop, bridge and forecastle deck)</p> <p>(5) All transverse webs with associated plating and longitudinals, and the transverse bulkhead complete in the fore peak tank and aft peak tank, see Notes 1 and 4</p> <p>(6) All keel plates outside the cargo tank length. Also additional bottom plates in way of cofferdams, machinery space and aft end of tanks</p> <p>(7) Plating of seachests. Also side shell plating in way of overboard discharges, as considered necessary by the Surveyor</p> <p>(8) Critical areas, as required by the Surveyor</p>
<p>Note 1. For areas in tanks where coatings are found to be in GOOD condition, as defined in <i>Pt 1, Ch 3, 1.5 Definitions</i>, the extent of thickness measurements may be specially considered, but not dispensed with in its entirety.</p> <p>Note 2. Transverse sections should be chosen where the largest reductions are likely to occur, or as revealed by deck plating measurements.</p> <p>Note 3. Where two or three transverse sections are required to be measured, at least one is to include a ballast tank within 0,5L amidships.</p> <p>Note 4. Transverse bulkhead complete including stiffening system.</p>		

8.7.2 In areas where substantial corrosion, as defined in *Pt 1, Ch 3, 1.5 Definitions*, has been noted, then additional measurements are to be carried out, as applicable, in accordance with *Table 3.8.5 Thickness measurement - Single and double hull chemical tankers - Bottom, inner bottom and hopper structure with substantial corrosion*, *Table 3.8.6 Thickness measurement - Single and double hull chemical tankers - Deck structure with substantial corrosion*, *Table 3.8.7 Thickness measurement - Single and double hull chemical tankers - Side shell and longitudinal bulkheads with substantial corrosion* and *Table 3.8.8 Thickness measurement - Single and double hull chemical tankers - Transverse watertight bulkheads and swash bulkheads with substantial corrosion* to determine the full extent of the corrosion pattern. The survey will not be considered complete until these additional thickness measurements have been carried out.

Table 3.8.5 Thickness measurement - Single and double hull chemical tankers - Bottom, inner bottom and hopper structure with substantial corrosion

Structural member	Extent of measurement	Pattern of measurement
(1) Bottom, inner bottom and hopper plating	Minimum of 3 bays across double bottom tank, including aft bay. Measurement around and under all suction strums	5 point pattern for each panel between longitudinals and floors
(2) Bottom, inner bottom and hopper longitudinals	Minimum of 3 longitudinals in each bay where bottom plating measured	3 measurements in line across flange and 3 measurements on vertical web
(3) Bottom girders, including watertight girders	At the fore and aft watertight floors and in centre of tanks	Vertical line of single measurements on girder plating with 1 measurement between each panel stiffener, or a minimum of 3 measurements. 2 measurements across face flat (if fitted)
(4) Bottom floors, including watertight floors	3 floors in bays where bottom plating measured, with measurements at both ends and middle	5 point pattern over 2 m ² area
(5) Hopper web frame ring	3 floors in bays where bottom plating measured	5 point pattern over 1 m ² of plating. Single measurements on flange
(6) Hopper transverse watertight bulkhead or swash bulkhead	(i) Lower $\frac{1}{3}$ of bulkhead	(i) 5 point pattern over 1 m ² of plating
	(ii) Upper $\frac{2}{3}$ of bulkhead	(ii) 5 point pattern over 2 m ² of plating
	(iii) Stiffeners (minimum of 3)	(iii) For web, 5 point pattern over span (2 measurements across web at each end and 1 at centre of span). For flange, single measurement at each end and centre of span
(7) Panel stiffening	Where applicable	Single measurements

Table 3.8.6 Thickness measurement - Single and double hull chemical tankers - Deck structure with substantial corrosion

Structural member	Extent of measurement	Pattern of measurement
(1) Deck plating	2 transverse bands across tank	Minimum of 3 measurements per plate per band
(2) Deck longitudinals	Every 3rd longitudinal in each of 2 bands with a minimum of 1 longitudinal	3 measurements in line vertically on webs and 2 measurements on flange (if fitted)
(3) Deck girders and brackets	At the fore and aft transverse bulkhead, bracket toes and in centre of tanks	Vertical line of single measurements on web plating with 1 measurement between each panel stiffener, or a minimum of 3 measurements. 2 measurements across flange. 5 point pattern on girder/bulkhead brackets
(4) Deck transverse webs	Minimum of 2 webs, with measurements at both ends and middle of span	5 point pattern over 1 m ² area. Single measurements on the flange
(5) Vertical web and transverse bulkhead in wing ballast tank (2 m from deck) – for double hull chemical tankers	Minimum of 2 webs, and both transverse bulkheads	5 point pattern over 1 m ² area
(6) Panel stiffening	Where applicable	Single measurements

Table 3.8.7 Thickness measurement - Single and double hull chemical tankers - Side shell and longitudinal bulkheads with substantial corrosion

Structural member	Extent of measurement	Pattern of measurement
(1) Side shell and longitudinal bulkhead plating:		
(i) Top and bottom strakes, and strakes in way of horizontal girders	(i) Plating between each pair of longitudinals in a minimum of 3 bays (along the tank)	(i) Single measurements
(ii) All other strakes	(ii) Plating between every 3rd pair of longitudinals on same 3 bays	(ii) Single measurements
(2) Side shell and longitudinal bulkhead longitudinals on:		
(i) Top and bottom strakes	(i) Each longitudinal in same 3 bays	(i) 3 measurements across web and 1 measurement on flange
(ii) All other strakes	(ii) Every 3rd longitudinal in same 3 bays	(ii) 3 measurements across web and 1 measurement on flange
(3) Longitudinals – brackets	Minimum of 3 at top, middle and bottom of tank in same 3 bays	5 point pattern over area of bracket
(4) Vertical web and transverse bulkheads of double side tanks (excluding deckhead area):		
(i) Strakes in way of horizontal girders	(i) Minimum of 2 webs and both transverse bulkheads	(i) 5 point pattern over approximately 2 m ² area
(ii) Other strakes	(ii) Minimum of 2 webs and both transverse bulkheads	(ii) 2 measurements between each pair of vertical stiffeners
(5) Web frames and cross ties for other tanks than double side tanks	3 webs with minimum of 3 locations on each web, including in way of cross tie connections and lower end bracket	5 point pattern over approximately 2 m ² area of webs, plus single measurements on flanges of web frame and cross ties
(6) Horizontal girders	Plating on each girder in a minimum of 3 bays	2 measurements between each pair of longitudinal girder stiffeners
(7) Panel stiffening	Where applicable	Single measurements

Table 3.8.8 Thickness measurement - Single and double hull chemical tankers - Transverse watertight bulkheads and swash bulkheads with substantial corrosion

Structural member	Extent of measurement	Pattern of measurement
(1) Upper and lower stool, where fitted	Transverse band within 25 mm of welded connection to inner bottom/deck plating Transverse band within 25 mm of welded connection to shelf plate	5 point pattern between stiffeners over 1 m length
(2) Top and bottom strakes, and strakes in way of horizontal stringers	Plating between pair of stiffeners at 3 locations; approximately $\frac{1}{4}$, $\frac{1}{2}$ and $\frac{3}{4}$ width of tank	5 point pattern between stiffeners over 1 m length
(3) All other strakes	Plating between pair of stiffeners at middle location	Single measurement
(4) Strakes in corrugated bulkheads	Plating for each change of scantling at centre of panel and at flange of fabricated connection	5 point pattern over approximately 1 m ² of plating
(5) Stiffeners	Minimum of 3 typical stiffeners	For web, 5 point pattern over span between bracket connections (2 measurements across web at each bracket connection and 1 at centre of span). For flange, single measurement at bracket toe and at centre of span
(6) Brackets	Minimum of 3 at top, middle and bottom of tank	5 point pattern over area of bracket
(7) Horizontal stringers	All stringers with measurements at both ends and middle	5 point pattern over 1 m ² area, plus single measurements near bracket toes and on flanges
(8) Deep webs and girders	Measurements at toe of bracket and centre of span	For webs, 5 point pattern over 1 m ² area. 3 measurements across face flat

8.8 Ships over 10 years old

8.8.1 Selected steel cargo pipes outside cargo tanks and ballast pipes passing through cargo tanks are to be:

- (a) Thickness measured at random or selected pipe lengths to be opened for internal inspection.
- (b) Pressure tested to the maximum working pressure.

Note Special attention is to be given to cargo/slop discharge piping through ballast tanks and void spaces.

■ **Section 9**
Ships for liquefied gases

9.1 General

9.1.1 The requirements of *Pt 1, Ch 3, 2 Annual Surveys - Hull and machinery requirements to Pt 1, Ch 3, 7 Special Survey - Oil tankers (including ore/oil ships and ore/bulk/oil ships) - Hull requirements* are to be complied with, as applicable.

9.1.2 Prior to the inspection of cargo tanks, surrounding spaces, associated piping, fittings and equipment, etc. the respective items are to be cleaned and thoroughly cleared of gas. Every precaution is to be taken to ensure safety during inspection.

9.1.3 The following documentation, as applicable, is to be available on board the ship:

- (a) Relevant instruction and information material such as cargo handling plans, filling limit information, cooling down procedures, etc.
- (b) A copy of the *18 Rules and Regulations for the Construction and Classification of Ships for the Carriage of Liquefied Gases in Bulk, July 2015*.
- (c) Test records of secondary barrier.
- (d) Loading and stability information, including damage stability.

9.1.4 For requirements of Special Survey for electrical equipment, see *Pt 1, Ch 3, 14 Electrical equipment*.

9.2 Annual Surveys – Basic requirements

9.2.1 The Annual Survey is preferably to be carried out during a loading or discharging operation. Access to cargo tanks or inerted hold spaces, necessitating gasfreeing/ aerating will normally not be necessary unless required by the Regulations.

9.2.2 The ship's log and operational records for the cargo containment system covering the period from the previous survey are to be examined. Any malfunction of the system entered in the log is to be investigated, the cause ascertained, and that part of the system at fault is to be found or placed in good order.

9.2.3 Instrumentation and safety systems are to be surveyed as follows:

- (a) The instrumentation of the cargo installations with regard to pressure, temperature and liquid level is to be verified in good working order by one or more of the following methods:
 - (i) Visual external examination.
 - (ii) Comparing of read outs from different indicators.
 - (iii) Consideration of read outs with regard to the actual cargo and/or actual conditions.
 - (iv) Examination of maintenance records with reference to cargo plant instrumentation maintenance manual.
 - (v) Verification of calibration status of the measuring instruments.
- (b) The low level, high level, and overfill alarms are to be examined and tested to ascertain that they are in working order.
- (c) The alarms associated with the following are to be tested as applicable:
 - (i) Cargo tank high and low pressure.
 - (ii) Cargo tank temperature.
 - (iii) Cargo hold pressure.
 - (iv) Interbarrier space pressure.
 - (v) Inner hull temperature.
 - (vi) Secondary barrier temperature.
 - (vii) Cargo Hold or Interbarrier bilge level detection.
- (d) Control devices for the cargo containment systems and cargo handling equipment, together with any associated shutdown and/or interlock, are to be checked under simulated working conditions and, if necessary, recalibrated. Such safety systems include but are not limited to:
 - (i) Cargo tank overfill protection including cargo pump, compressor and other cargo machinery automatic shutdown.
 - (ii) Cargo pump, compressor and other cargo machinery shutdown on low cargo tank pressure or cargo tank and interbarrier/hold space differential pressure.
 - (iii) Cargo pump automatic shutdown on low level or current;
- (e) The emergency shutdown system is to be tested, without flow in the pipe lines, to verify that the system will cause the cargo pumps, compressors and other cargo machinery, as applicable, to stop.
- (f) Consideration will be given to the acceptance of simulated tests, provided that they are carried out at the cargo temperature, or comprehensive maintenance records, including details of tests held, in accordance with the cargo plant instrumentation maintenance manual.

9.2.4 Cargo gas leakage detection systems are to be examined and tested to ascertain that they are in working order and calibrated using sample gas.

9.2.5 Inert gas/dry air installations including the means for prevention of backflow of cargo vapour to gas-safe spaces are to be verified as being in satisfactory operating condition.

9.2.6 Ventilation systems and air locks in working spaces are to be checked for satisfactory operation.

9.2.7 Cargo pipeline, valves and fittings are to be generally examined, with special reference to expansion bellows, supports and vapour seals on insulated pipes. It is to be verified that all accessible cargo piping systems are electrically bonded to the hull.

9.2.8 Portable and/or fixed drip trays, or insulation for deck protection in the event of cargo leakage, are to be examined for condition.

9.2.9 The means for accomplishing gas tightness of the wheelhouse doors and windows is to be examined. All windows and side-scuttles within the area required to be of the fixed type (non-opening) are to be examined for gas tightness. The closing devices for all air intakes and openings into accommodation spaces, service spaces, machinery spaces, control stations and approved openings in superstructures and deckhouses facing the cargo area or bow and stern loading/unloading arrangements are to be examined. For ships carrying toxic gases such devices should be capable of being operated from inside the space.

9.2.10 Venting systems, including protection screens if provided, for the cargo tanks, inter-barrier spaces and hold spaces are to be visually examined externally. It is to be verified that the cargo tank relief valves are sealed and that the certificate for the relief valves opening/closing pressures is on board the ship.

9.2.11 Mechanical ventilation fans in gas hazardous zones and spaces are to be visually examined. Adequate spare parts should be carried for each type of fan installed.

9.2.12 Electrical equipment, cables and supports in gas hazardous zones and spaces shall be examined as far as practicable. Alarms and safety systems associated with pressurised lighting systems and any safety device associated with nonsafe type electrical equipment that is protected by air-locks are to be verified.

9.2.13 Heating arrangements, if fitted, for cofferdams and other spaces shall be verified in good working order.

9.2.14 All accessible gas-tight bulkhead penetrations including gas-tight shaft sealings are to be visually examined.

9.2.15 The sealing arrangements for tanks or tank domes penetrating decks or tank covers are to be externally examined.

9.2.16 The survey is to consist of an examination for the purpose of ensuring, as far as practicable, that the hull and piping are maintained in a satisfactory condition.

(a) The examination of the hull and piping is to include the following:

- hull plating and closing appliances as far as can be seen
- watertight penetrations as far as practicable
- weather decks
- flame screens on vents to all bunker tanks
- bunker and vent piping systems

(b) The examination of the cargo pump rooms and compressor rooms and, as far as practicable, pipe tunnels if fitted is to include the following:

- all pump room and compressor room bulkheads for signs of leakage or fractures and, in particular, the sealing arrangements of all penetrations of pump room and compressor room bulkheads
- condition of all piping systems (for cargo piping systems, see *Pt 1, Ch 3, 9.2 Annual Surveys – Basic requirements 9.2.7*).

9.2.17 The Surveyor is to carry out an examination and thickness measurement of structure identified at the previous Special Survey or Intermediate Survey as having substantial corrosion, as defined in *Pt 1, Ch 3, 1.5 Definitions*. The extent of thickness measurements is to be increased in accordance with *Table 3.9.4 Thickness measurement - Ships for liquefied gases - Structural areas with substantial corrosion* to determine the full extent of the corrosion pattern. The survey will not be considered complete until these additional thickness measurements have been carried out.

9.3 Annual Surveys – Reliquefaction/refrigeration equipment

9.3.1 Where reliquefaction or refrigeration equipment for cargo temperature and pressure control is fitted, the following are to be examined, so far as practicable:

- (a) The machinery under working conditions.
- (b) The shells of all pressure vessels in the system, externally. Insulation need not be removed for this examination, but any deterioration of insulation or evidence of dampness which could lead to external corrosion of the vessels or their connections, is to be investigated.
- (c) Primary refrigerant gas and liquid pipes, cargo vapour and liquid condensate pipes and condenser cooling water pipes. Insulation need not be removed, but any deterioration or evidence of dampness is to be investigated.
- (d) The reliquefaction/refrigeration plant spare gear.

9.3.2 Reference should be made to the Special Survey requirements for guidance on Continuous Survey arrangements.

9.4 Annual Surveys – Methane burning equipment and other equipment components

9.4.1 The following components are to be generally examined externally. If insulation is fitted, this need not be removed, but any deterioration of insulation, or evidence of dampness which could lead to external corrosion of the vessels or their connections, is to be investigated:

- (a) Heat exchangers and pressure vessels for use with methane burning in boilers or machinery.
- (b) Cargo heaters, vaporisers, masthead heaters and other miscellaneous pressure vessels.

9.4.2 Controls and interlocks are to be checked.

9.4.3 Alarm systems are to be checked to ascertain that they are in working order.

9.4.4 Exhaust fans and/or pressurising system for gas trunking are to be tested.

9.5 Annual Surveys – Cargo containment systems

9.5.1 Where the insulation arrangement is such that the insulation cannot be examined, the surrounding structures of wing tanks, double bottom tanks and cofferdams are to be examined for cold spots, prior to the survey. This examination is to be held at a convenient cargo discharge operation with the cargo tanks loaded at approximately the minimum notation temperature.

9.5.2 On application by the Owner, consideration will be given to the cold spot examination, where applicable, being carried out by the ship's staff.

9.5.3 When tests are required after repairs, independent cargo tanks, other than independent tanks type C, are to be tested by hydraulic or hydropneumatic means as appropriate. Test heads and pressures should be as defined in *Part E - Tank Types of the Rules and Regulations for the Construction and Classification of Ships for the Carriage of Liquefied Gases in Bulk*. Cargo tanks of the membrane or semi-membrane type are to be tested by means of a detectable gas in the inter-barrier spaces and discolouring paint on the weld seams of the cargo tanks wall, or other suitable means. Independent cargo tanks of type C are to be tested hydraulically at 1,25 times the approved maximum vapour pressure.

9.5.4 For membrane containment systems, the Surveyor is to receive confirmation from the Master that the nitrogen control system for insulation and inter-barrier spaces is operating normally.

9.6 Intermediate Surveys

9.6.1 The Intermediate Survey intends to supplement the Annual Survey by testing cargo handling installations with related automatic control, alarm and safety systems for correct functioning. The Intermediate Survey is preferably to be carried out with the ship in a gas-free condition. The extent of the testing required for the Intermediate Survey will normally be such that the survey cannot be carried out during a loading or discharging operation.

9.6.2 In addition to the requirements for Annual Survey and the requirements of *Pt 1, Ch 3, 3.2 Intermediate Surveys 3.2.1*, the following are to be dealt with as applicable:

- (a) Examination of means for draining the vent piping system.
- (b) Verification that pipelines and cargo tanks are electrically bonded to the hull.
- (c) Verification that the heating arrangements, if any, for steel structures are satisfactory.
- (d) Where required by the manufacturer's maintenance instructions, cargo tank and inter-barrier space pressure and vacuum relief valve settings are to be checked and adjusted as required. Cargo tank pressure relief valve harbour settings are also to be checked, if applicable. Cargo tank pressure relief valves are to lift at a pressure not more than the percentage given below, above the maximum vapour pressure for which the tanks have been approved.
 - For 0 to 1,5 bar (0 to 1,5 kgf/cm²), 10 per cent.
 - For 1,5 to 3,0 bar (1,5 to 3,0 kgf/cm²), 6 per cent.
 - For pressures exceeding 3,0 bar (3,0 kgf/cm²), 3 per cent.
 - Valves may be removed from the tanks for the purpose of checking.
- (e) A General Examination within the zones and spaces deemed as hazardous, such as cargo compressor rooms and spaces adjacent to and zones above cargo areas, for defective and non-certified safe-type electrical equipment, improperly installed, defective and dead wiring. An electrical insulation resistance test of the circuits terminating in, or passing through the hazardous zones and spaces, is to be carried out. If the ship is not in a gas free condition the results of previously recorded test readings may be accepted.

9.6.3 For ships over 5 years of age and up to 10 years of age, an overall survey of representative ballast tanks is to be carried out. Where a hard protective coating is found to be in POOR condition, as defined in *Pt 1, Ch 3, 1.5 Definitions*, where a soft or semi-hard coating has been applied or where a protective coating was not applied from the time of construction, the survey is to be extended to other ballast tanks of the same type.

9.6.4 For ships over 10 years of age, an overall survey of all ballast tanks is to be carried out.

- (a) If such examinations reveal no visible structural defects, the examination may be limited to verification that the corrosion prevention system remains in GOOD or FAIR condition.
- (b) The condition of the corrosion prevention system identified during the Survey may result in the tanks being subject to further examination at Annual Surveys, in accordance with *Pt 1, Ch 3, 2.2 Annual Surveys 2.2.28*. For independent double bottom ballast tanks, the examination at Annual Surveys will be at the discretion of the Surveyor.

9.6.5 The minimum requirements for Close-up Survey are given in *Table 3.9.1 Ships for liquified gases - Intermediate Surveys*.

Table 3.9.1 Ships for liquified gases - Intermediate Surveys

Ships between 10 and 15 years old	Ships greater than 15 years old
(1) Close-up survey of all web frames and both transverse bulkheads in a representative ballast tank, see Note 2 and 3.	(1) Close-up survey of all web frames and both transverse bulkheads in a two representative ballast tanks, see Notes 2 and 3.
(2) Close-up survey of the upper part of one web frame in one other representative ballast tank.	
(3) Close-up survey of one transverse bulkhead in one other representative ballast tank, see Note 3.	
<p>Note 1. Ballast tanks include topside, double hull side, double bottom, hopper side, or any combined arrangement of the aforementioned, and peak tanks where fitted.</p> <p>Note 2. Complete transverse web frame including adjacent structural members.</p> <p>Note 3. Transverse bulkhead complete, including girder system and adjacent structural members and adjacent longitudinal bulkhead structure.</p> <p>Note 4. For areas in tanks where coatings are found to be in GOOD condition, as defined in <i>Pt 1, Ch 3, 1.5 Definitions</i>, the extent of Close-up Survey may be specially considered.</p> <p>Note 5. The Surveyor may extend the Close-up Survey, if deemed necessary, taking into account the maintenance of the tanks under survey, the condition of the corrosion prevention system, the structural arrangements or details which have suffered defects in similar spaces or on similar ships and tanks having structures approved with reduced scantlings.</p> <p>Note 6. For ships having independent cargo tanks of Type C, with a midship section similar to that of a general cargo ship, the extent of Close-up Survey may be specially considered.</p>	

9.7 Special Survey I (ships five years old) – General requirements

9.7.1 The requirements of *Pt 1, Ch 3, 9.1 General* to *Pt 1, Ch 3, 9.6 Intermediate Surveys* are to be complied with.

9.7.2 The requirements for Close-up Survey and thickness measurement are given in *Pt 1, Ch 3, 9.12 Close-up Survey* and *Pt 1, Ch 3, 9.13 Thickness measurement*.

9.7.3 All cargo tanks are to be examined internally, also externally so far as practicable, particular attention being paid to the plating in way of supports of securing arrangements, tower structures, seatings and pipe connections, also to sealing arrangements in way of the deck penetrations. Provided that the structural examination is satisfactory, that the gas leakage monitoring systems have been found to be operating satisfactorily and that the voyage records have not shown any abnormal operation, cargo tanks do not require to be hydraulically tested. The primary membranes of 'Gas Transport' design should be examined with the primary insulation space under a vacuum of at least -500 mbar gauge. For 'Moss Type' LNG cargo tanks, the Structural Transition Joints (STJ) are to be examined at the port, starboard, forward and aft locations. Insulation is to be removed as required. Non-destructive testing may be required where considered necessary. For membrane containment systems with corrugated primary barriers, in view of the sloshing loads experienced in service, measurements should, if required, be taken inside the cargo tanks of deformations of the primary barrier corrugations in order to assess the condition of the containment system in accordance with the system designer's procedures as approved by LR.

9.7.4 The non-destructive testing of cargo tanks is to be carried out as follows:

- (a) Non-destructive testing is to supplement cargo tank inspection with special attention to be given to the integrity of the main structural members, tank shell and highly stressed parts, including welded connections as deemed necessary by the Surveyor. The following items are, inter alia, considered as highly stressed parts:
- (i) Cargo tanks supports and anti-rolling/antipitching devices;
 - (ii) Web frames or stiffening rings;
 - (iii) Swash bulkhead boundaries;
 - (iv) Dome and stump connections to tank shell;
 - (v) Foundations for pumps, towers, ladders, etc.;
 - (vi) Pipe connections.
- (b) For independent tanks of Type B, the extent of non-destructive testing shall be as given in the programme specially prepared for the cargo tank design.
- (c) Independent cargo tanks of Type C are to be subjected to non-destructive testing of the plating in way of supports and also at selected lengths of welds. Where such testing raises doubt as to the structural integrity, a hydraulic test should be carried out at 1,25 times the approved maximum vapour pressure. Alternatively, consideration will be given to pneumatic testing under special circumstances, provided full details are submitted for approval.
- (d) At each alternate Special Survey (i.e. SSII, SSIV and so on), all independent cargo tanks of Type C are to be either:
- (i) Hydraulically or hydro-pneumatically tested to 1,25 times MARVS, followed by non-destructive testing in accordance with paragraph *Pt 1, Ch 3, 9.7 Special Survey I (ships five years old) – General requirements 9.7.4* above, or,
 - (ii) Subjected to a thorough, planned, non-destructive testing. This testing is to be carried out in accordance with a programme specially prepared for the tank design. If a special programme does not exist, the following applies:
 - cargo tank supports and anti-rolling/anti-pitching devices;
 - stiffening rings;
 - Y-connections between tank shell and a longitudinal bulkhead of bi-lobe tanks;
 - swash bulkhead boundaries;
 - dome and sump connections to the tank shell;
 - foundations for pumps, towers, ladders etc.;
 - pipe connections.

At least 10 per cent of the length of the welded connections in each of the above mentioned areas is to be tested. This testing is to be carried out internally and externally as applicable. Insulation is to be removed as necessary for the required non-destructive testing.

9.7.5 Deck mounted cargo storage tanks are to be examined in the same manner as main cargo tanks.

9.7.6 For membrane containment systems, a tightness test of the primary and secondary barrier shall be carried out in accordance with the system designer's procedures and acceptance criteria as approved by LR. Low differential pressure tests may be used for monitoring the cargo containment system performance, but are not considered an acceptable test for the tightness of the secondary barrier. For membrane containment systems with glued secondary barriers, if the designer's threshold values are exceeded, an investigation is to be undertaken and additional testing such as thermographic or acoustic emissions testing should be carried out.

9.7.7 Where a cargo tank or the hull structure is insulated and the insulation is accessible, the insulation should be examined externally, together with any vapour or protective barrier, and sections removed for examination, if considered necessary by the Surveyor. Special attention should be given to insulation in way of chocks, supports and keys. Portions of the insulation are also to be removed, if required by the Surveyor, to enable the condition of the plating to be ascertained. Where the insulation is not accessible, see *Pt 1, Ch 3, 9.5 Annual Surveys – Cargo containment systems 9.5.1*.

9.7.8 Cargo tank internal pipes and fittings are to be examined, and all valves and cocks in direct communication with the interiors of the tanks are to be opened out for inspection and the connection pipes are to be examined internally, so far as practicable.

9.7.9 Relief valves are to be surveyed as follows:

- (a) The pressure relief valves for the cargo tanks are to be opened for examination, adjusted, function tested, and sealed. If the cargo tanks are equipped with relief valves with non-metallic membranes in the main or pilot valves, such non-metallic membranes are to be replaced.

- (b) Pressure relief valves are subsequently to be adjusted to lift at a pressure in accordance with *Pt 1, Ch 3, 9.6 Intermediate Surveys 9.6.2*. Relief valve harbour settings are to be checked, if applicable. Valves may be removed from the shell for the purpose of making this adjustment under pressure of air or other suitable gas.
- (c) Where a proper record of continuous overhaul and retesting of individually identifiable relief valves is maintained, consideration will be given to acceptance on the basis of opening, internal examination, and testing of a representative sampling of valves, including each size and type of liquefied gas or vapour relief valve in use, provided there is logbook evidence that the remaining valves have been overhauled and tested since crediting of the previous Special Survey.
- (d) Relief valves on cargo gas and liquid pipelines are to have their pressure settings checked. The valves may be removed from the pipelines for this purpose. At the Surveyor's discretion a sample of each size and type of valve may be opened for examination and testing.

9.7.10 All cargo pumps, cargo booster pumps and cargo vapour pumps are to be opened out for examination. If requested by the Owner, these items may be examined on a Continuous Survey basis, provided the interval between examination of each item does not exceed five years. Pumping systems for inter-barrier spaces are to be checked and verified to be in good working order.

9.7.11 Piping for cargo and process systems including valves, actuators and compensators are to be opened for examination. Insulation may need to be removed, as deemed necessary, to ascertain the condition of the piping. If any doubt exists regarding the integrity of the piping based upon visual examination then, where deemed necessary by the Surveyor, a pressure test at 1,25 times MARVS for the pipeline is to be carried out. The complete piping systems are to be tested for leaks after re-assembly.

9.7.12 Equipment for the production of inert gas is to be examined and shown to be operating satisfactorily within the gas specification limits. Pipelines, valves, etc. for the distribution of the inert gas are to be generally examined. Pressure vessels for the storage of inert gas are to be examined internally and externally and the securing arrangements are to be specially examined. Pressure relief valves are to be demonstrated to be in good working order. Liquid nitrogen storage vessels are to be examined, so far as practicable, and all control equipment, alarms and safety devices are to be verified as operational.

9.7.13 Gastight bulkhead shaft seals are to be opened out so that the sealing arrangements may be checked.

9.7.14 Sea connections associated with the cargo handling equipment are to be opened out when the ship is in dry-dock.

9.7.15 The arrangements for discharging the cargo overboard in an emergency are to be checked.

9.8 Special Survey I (ships five years old) – Reliquefaction/refrigeration equipment

9.8.1 Each reciprocating compressor is to be opened out. Cylinder bores, pistons, piston rods, connecting rods, valves and seats, glands, relief devices, suction filters and lubricating arrangements are to be examined. Crankshafts are to be examined, but crankcase glands and the lower half of main bearings need not be exposed if the Surveyor is satisfied with the alignment and wear.

9.8.2 Where other than reciprocating-type compressors are fitted, or where there is a program of replacement instead of surveys on board, alternative survey arrangements will be considered. Each case will be given individual consideration.

9.8.3 The water end covers of condensers are to be removed for examination of the tubes, tubeplates and covers.

9.8.4 Refrigerant condenser cooling water pumps, including standby pump(s) which may be used on other services, are to be opened out for examination.

9.8.5 Where a pressure vessel is insulated, sufficient insulation is to be removed, especially in way of connections and supports, to enable the vessel's condition to be ascertained.

9.8.6 Insulated pipes are to have sufficient insulation removed to enable their condition to be ascertained. Vapour seals are to be specially examined for their condition.

9.8.7 The Surveyor is to satisfy himself that all pressure relief valves and/or safety discs throughout the system are in good order. No attempt, however, is to be made to test primary refrigerant pressure relief valves on board ship.

9.8.8 The items covered by *Pt 1, Ch 3, 9.8 Special Survey I (ships five years old) – Reliquefaction/refrigeration equipment 9.8.1 to Pt 1, Ch 3, 9.8 Special Survey I (ships five years old) – Reliquefaction/refrigeration equipment 9.8.4* may, at the request of the Owner, be examined on a Continuous Survey basis provided the interval between examination of each item does not exceed five years.

9.9 Special Survey I (ships five years old) – Methane burning equipment

9.9.1 Where methane is used as fuel for main propulsion purposes, the associated compressors and heat exchangers are to be opened out and examined as for reliquefaction/refrigeration equipment. The steam side of steam heaters is to be hydraulically tested to 1,5 times the design pressure.

9.9.2 Methane gas pipe trunks or casings are to be generally examined and the exhaust or inerting arrangements for these trunks are to be verified.

9.9.3 All alarms associated with the methane burning systems are to be verified.

9.10 Special Survey II and Special Surveys thereafter (ships 10 years old and over)

9.10.1 The requirements of *Pt 1, Ch 3, 9.1 General* to *Pt 1, Ch 3, 9.9 Special Survey I (ships five years old) – Methane burning equipment* are to be complied with.

9.10.2 Water cooled condensers in which the primary refrigerant is in contact with the shell are to have the end covers removed and the shell pneumatically tested to a pressure equal to the designed working pressure.

9.10.3 All other pressure vessels in the reliquefaction/refrigeration system, methane burning system and other handling systems are to be pneumatically tested to a pressure equal to the designed working pressure.

9.10.4 The requirements for Close-up Survey and thickness measurement are given in *Pt 1, Ch 3, 9.12 Close-up Survey* and *Pt 1, Ch 3, 9.13 Thickness measurement*.

9.11 Special Survey III and Special Surveys thereafter (ships 15 years old and over)

9.11.1 The requirements of *Pt 1, Ch 3, 9.1 General* to *Pt 1, Ch 3, 9.10 Special Survey II and Special Surveys thereafter (ships 10 years old and over)* are to be complied with.

9.11.2 For independent tanks of Type B, the Owner is to submit proposals for the extent of non-destructive testing of the cargo tanks well in advance of the Special Survey.

9.12 Close-up Survey

9.12.1 The minimum requirements for Close-up Survey are given in *Table 3.9.2 Close-up Survey - Ships for liquefied gases*.

9.12.2 The Surveyor may extend the Close-up Survey, if deemed necessary, taking into account the maintenance of the tanks under survey, the condition of the corrosion prevention system and the structural arrangements or details which have suffered defects in similar spaces or on similar ships and tanks having structures approved with reduced scantlings.

9.12.3 For areas in tanks where coatings are found to be in GOOD condition, as defined in *Pt 1, Ch 3, 1.5 Definitions*, the extent of Close-up Survey may be specially considered.

Table 3.9.2 Close-up Survey - Ships for liquefied gases

Special Survey I (Ships 5 years old)	Special Survey II (Ships 10 years old)	Special Survey III (Ships 15 years old)	Special Survey IV (Ships 20 years old and over)
(1) One web frame in: (a) a topside ballast tank (b) a hopper side ballast tank (c) a double hull side ballast tank See Note 2. (2) One transverse bulkhead in a ballast tank, see Note 4.	(1) All web frames in either a topside ballast tank or a double hull side ballast tank, see Notes 2 and 5. (2) One web frame in each remaining ballast tank, see Note 2. (3) One transverse bulkhead in each ballast tank, see Note 3.	(1) All web frames in all ballast tanks, see Note 2. (2) All transverse bulkheads in all ballast tanks, see Note 3.	(1) All web frames in all ballast tanks, see Note 2. (2) All transverse bulkheads in all ballast tanks, see Note 3.
<p>Note 1. Ballast tanks include topside, double hull side, double bottom, hopper side, or any combined arrangement of the aforementioned, and peak tanks where fitted.</p> <p>Note 2. Complete transverse web frame ring including adjacent structural members.</p> <p>Note 3. Transverse bulkhead complete, including girder system and adjacent structural members and adjacent longitudinal bulkhead structure.</p> <p>Note 4. Transverse bulkhead lower part including girder system and adjacent structural members.</p> <p>Note 5. If topside tanks and double hull side tanks are not fitted, then another ballast tank is to be selected.</p> <p>Note 6. For ships having independent cargo tanks of Type C, with a midship section similar to that of a general cargo ship, the extent of Close-up Survey may be specially considered.</p>			

9.13 Thickness measurement

9.13.1 The minimum requirements for thickness measurement are given in *Table 3.9.3 Thickness measurement - Ships for liquefied gases*.

9.13.2 In areas where substantial corrosion, as defined in *Pt 1, Ch 3, 1.5 Definitions*, has been noted, then additional measurements are to be carried out in accordance with *Table 3.9.4 Thickness measurement - Ships for liquefied gases - Structural areas with substantial corrosion* to determine the full extent of the corrosion pattern. The survey will not be considered complete until these additional thickness measurements have been carried out.

Table 3.9.3 Thickness measurement - Ships for liquefied gases

Special Survey I (Ships 5 years old)	Special Survey III (Ships 15 years old)	Special Survey IV and subsequent (Ships 20 years old and over)
<p>(1) 1 section of deck plating for the full beam of the ship within 0,5L amidships in way of a ballast tank, if any</p> <p>(2) Measurements for general assessment and recording of corrosion pattern of the structural members subject to Close-up Survey in accordance with <i>Table 3.9.2 Close-up Survey - Ships for liquefied gases</i></p> <p>(3) Critical areas, as required by the Surveyor</p>	<p>(1) Within the cargo area:</p> <p>(a) Each deck plate</p> <p>(b) 2 transverse sections</p> <p>(2) Measurements for general assessment and recording of corrosion pattern of the structural members subject to Close-up Survey in accordance with <i>Table 3.9.2 Close-up Survey - Ships for liquefied gases</i></p>	<p>(1) Within the cargo area:</p> <p>(a) Each deck plate</p> <p>(b) 3 transverse sections</p> <p>(c) Each bottom plate</p> <p>(d) Duct keel plating and internals</p> <p>(2) Measurements for general assessment and recording of corrosion pattern of the structural members subject to Close-up Survey in accordance with <i>Table 3.9.2 Close-up Survey - Ships for liquefied gases</i></p>
<p>Special Survey II (Ships 10 years old)</p>	<p>(3) Selected wind and water strakes outside the cargo area</p>	<p>(3) All wind and water strakes over the full length of the ship, port and starboard</p>
<p>(1) Within the cargo area:</p> <p>(a) Each deck plate</p> <p>(b) 1 transverse section</p> <p>(2) Measurements for general assessment and recording of corrosion pattern of the structural members subject to close-up survey in accordance with <i>Table 3.9.2 Close-up Survey - Ships for liquefied gases</i></p> <p>(3) Selected wind and water strakes outside the cargo area</p> <p>(4) Critical areas, as required by the Surveyor</p>	<p>(4) All wind and water strakes within the cargo area</p> <p>(5) All transverse webs with associated plating and longitudinals, and the transverse bulkhead complete in the fore peak tank and aft peak tank, see Notes 1 and 4</p> <p>(6) Critical areas, as required by the Surveyor</p>	<p>(4) Remaining exposed main deck plating not considered in item (1) and representative exposed superstructure deck plating (i.e. poop, bridge and fore-castle deck)</p> <p>(5) All transverse webs with associated plating and longitudinals, and the transverse bulkhead complete in the fore peak tank and aft peak tank, see Notes 1 and 4</p> <p>(6) All keel plates outside the cargo tank length. Also additional bottom plates in way of cofferdams, machinery space and aft end of tanks</p> <p>(7) Plating of seachests. Also side shell plating in way of overboard discharges, as considered necessary by the Surveyor</p> <p>(8) Critical areas, as required by the Surveyor</p>
<p>Note 1. For areas in tanks where coatings are found to be in GOOD condition, as defined in <i>Pt 1, Ch 3, 1.5 Definitions</i>, the extent of thickness measurements may be specially considered, but not dispensed with in its entirety.</p> <p>Note 2. Transverse sections should be chosen where the largest reductions are likely to occur, or as revealed by deck plating measurements.</p> <p>Note 3. Where two or three transverse sections are required to be measured, at least one is to include a ballast tank within 0,5L amidships.</p> <p>Note 4. Transverse bulkhead complete including stiffening system.</p> <p>Note 5. Where considered necessary by the Surveyor, the inner bottom plating and adjacent tank supports are to be subject to thickness measurement for general assessment and recording of the corrosion pattern.</p> <p>Note 6. For those ships designated to carry light oils in the independent cargo tanks, thickness measurement of the independent cargo tank structure is to be carried out as considered necessary by the Surveyor.</p>		

Table 3.9.4 Thickness measurement - Ships for liquefied gases - Structural areas with substantial corrosion

Structural member	Extent of measurement	Pattern of measurement
Plating	Suspect area and adjacent plates	5 point pattern over 1 m ² of plating
Stiffeners	Suspect area	3 measurements each in line across web and flange

■ **Section 10**
Dredgers, hopper dredgers, sand carriers, hopper barges and reclamation craft

10.1 General

10.1.1 The requirements of this Section are to be complied with, as applicable, in addition to the survey requirements of *Pt 1, Ch 3, 2 Annual Surveys - Hull and machinery requirements, Pt 1, Ch 3, 3 Intermediate Surveys - Hull and machinery requirements, Pt 1, Ch 3, 4 Docking Surveys and In-water Surveys - Hull and machinery requirements* and *Pt 1, Ch 3, 5 Special Survey - General - Hull requirements*. Where surveys are required on dredging or hopper equipment such as gantries, bottom doors and their operating gear, positioning spuds and suction pipe attachments or split hull devices such as actuating and locking devices, these will be limited to the extent considered necessary by the Surveyor to satisfy himself that their condition or malfunction will not adversely affect the ship's structure.

10.1.2 Where applicable, the Docking Survey is to include the examination of hopper doors and their fittings, and of hopper valves.

10.2 Special Surveys

10.2.1 On ships up to 10 years old (Special Survey I and II):

- (a) Hoppers are to be cleared and cleaned as necessary and examined.
- (b) Where applicable, hopper doors or valves are to be opened and closed, so far as practicable, but keel blocks need not normally be moved specially to permit this to be done.
- (c) The integrity of hopper overflows and diluting water inlet and distribution structures is to be confirmed. Weir valves and sluices are to be tested to ensure proper operation, particular attention being paid to the lower weir when weirs are fitted at more than one level.
- (d) Attention is to be given to shell plating in way of hopper overflows.
- (e) The attachment to the ship's structure of all main items of dredging equipment, including gantries, 'A' frames, spud controlgear supports and items provided to facilitate separation of split hulls including hinge pin gudgeons, anchorages for rams and locking devices, is to be carefully examined to ensure that no fracture is present.

10.2.2 On ships 15 years old and over (Special Survey III and subsequent Special Surveys):

- (a) Attention is to be given by the Surveyor to the structure in way of dredging pumps.
- (b) Hopper doors, valves and items provided to facilitate separation of split hulls are to be checked for proper operation, and their hinges, controlgear and other fittings are to be examined for wear or distortion. All seals and wear-down strips are to be replaced if necessary, but a watertight seal is not normally required. Attention is to be paid to areas likely to be suffering from excessive erosion.
- (c) Those items of dredging gear and equipment whose efficiency is not part of classification but whose failure or malfunctioning is, nevertheless, likely to adversely affect the ship's structure, are to be examined to ensure that the structural integrity of the ship is maintained.

■ Section 11**Machinery surveys - General requirements****11.1 Annual, Intermediate and Docking Surveys**

11.1.1 For Annual, Intermediate and Docking Surveys, see *Pt 1, Ch 3, 2 Annual Surveys - Hull and machinery requirements, Pt 1, Ch 3, 3 Intermediate Surveys - Hull and machinery requirements* and *Pt 1, Ch 3, 4 Docking Surveys and In-water Surveys - Hull and machinery requirements*.

11.1.2 For ships assigned the notation 'laid-up', a general examination of the machinery is to be carried out in lieu of the normal Annual Survey requirements.

11.2 Complete Surveys

11.2.1 While the ship is in dry-dock, all openings to the sea in the machinery spaces and pump-rooms, together with the valves, cocks and the fastenings with which these are connected to the hull, are to be examined.

11.2.2 All shafts (except screwshafts and tube shafts, for which special arrangements are detailed in *Pt 1, Ch 3, 17 Screwshafts, tube shafts and propellers*), thrust block and all bearings are to be examined. The lower halves of bearings need not be exposed if alignment and wear are found to be acceptable.

11.2.3 An examination is to be made of all reduction gears complete with all wheels, pinions, shafts, bearings and gear teeth, thrust bearings and incorporated clutch arrangements.

11.2.4 The following auxiliaries and components are also to be examined:

- (a) Auxiliary engines, auxiliary air compressors with their intercoolers, filters and/or oil separators and safety devices, and all pumps and components used for essential services.
- (b) Steering machinery.
- (c) Windlass and associated driving equipment, where fitted.
- (d) Evaporators (other than those of vacuum type) and their safety valves, which should be seen in operation under steam.
- (e) The holding down bolts and chocks of main and auxiliary engines, gearcases, thrust blocks and intermediate shaft bearings.

11.2.5 All air receivers for essential services, together with their mountings, valves and safety devices, are to be cleaned internally and examined internally and externally. If internal examination of the air receivers is not practicable, they are to be tested hydraulically to 1,3 times the working pressure.

11.2.6 The valves, cocks and strainers of the bilge system, including bilge injection, are to be opened up as considered necessary by the Surveyor and, together with pipes, are to be examined and tested under working conditions. The fuel oil, feed, lubricating oil and cooling water systems, as well as the ballast connections and blanking arrangements to deep tanks which may carry liquid or dry cargoes, together with all pressure filters, heaters and coolers used for essential services, are to be opened up and examined or tested, as considered necessary by the Surveyor. All safety devices for the foregoing items are to be examined.

11.2.7 Water ingress detection arrangements fitted on single hold cargo ships having length less than 80 m and bulk carriers and flooding detection systems fitted on passenger ships are to be tested to demonstrate that they are in good working order. Alternatively, this testing may be conducted during the required hull Special Survey space examinations, see *also Pt 1, Ch 3, 5.3 Examination and testing*.

11.2.8 Fuel tanks which do not form part of the ship's structure are to be examined and, if considered necessary by the Surveyor, they are to be tested to the pressure specified for new tanks. The tanks need not be examined internally at the first survey if they are found satisfactory on external inspection. The mountings, fittings and remote controls of all fuel oil tanks are to be examined, so far as practicable.

11.2.9 Where remote and/or automatic controls are fitted for essential machinery, they are to be tested to demonstrate that they are in good working order.

11.2.10 For ships fitted with a dynamic positioning system, the control system and associated machinery items are to be examined and tested under operating conditions to an approved Test Schedule.

11.2.11 In addition to the above, detailed requirements for steam and gas turbines and steam engines, oil engines, electrical installations and boilers are given in *Pt 1, Ch 3, 12 Turbines and steam engines - Detailed requirements, Pt 1, Ch 3, 13 Reciprocating internal combustion engines - Detailed requirements, Pt 1, Ch 3, 14 Electrical equipment* and *Pt 1, Ch 3, 15 Boilers*

respectively. In certain instances, upon application by the Owner or where indicated by the maker's servicing recommendations, the Committee will give consideration to the circumstances where deviation from these detailed requirements is warranted, taking account of design, appropriate indicating equipment (e.g. vibration indicators) and operational records.

11.2.12 For **natural gas fuel installations** see also *Pt 1, Ch 3, 23.8 Complete Surveys – General requirements* and *Pt 1, Ch 3, 23.9 Complete Surveys – Natural gas fuelled consumers and other equipment*.

■ Section 12 Turbines and steam engines - Detailed requirements

12.1 Complete Surveys

12.1.1 The requirements of *Pt 1, Ch 3, 11 Machinery surveys - General requirements* are to be complied with.

12.1.2 The working parts of the main engine and attached pumps, and of auxiliary machinery used for essential services, are to be opened out and examined, including:

(a) For reciprocating engines:

- Bulkhead stop valves and manoeuvring valves.
- Cylinders.
- Pistons, piston rods, connecting rods, crossheads and guides.
- Valves and valve gear.
- Crankshaft.

(b) For turbine machinery:

- Blading and rotors.
- Flexible couplings.
- Casings.

12.1.3 In gas turbines and free piston gas generators, the following parts, also, are to be opened out and examined:

- Impellers or blading.
- Rotors and casings of the air compressors.
- Combustion chambers and burners.
- Intercoolers and heat exchangers.
- Gas and air piping, and fittings.
- Starting and reversing arrangements.

12.1.4 Where gas turbines operate in conjunction with free piston gas generators, the following parts of the latter are to be opened out and examined:

- Gas and air compressor cylinders and pistons.
- Compressor end covers.
- Valves and valve gear.
- Fuel pumps and fittings.
- Synchronizing and control gear.
- Cooling system.
- Explosion relief devices.
- Gas and air piping.
- Receivers and valves, including by-pass arrangements.

12.1.5 Condensers, steam reheaters, desuperheaters which are not incorporated in the boilers, and any other appliances used for essential services, are to be examined to the satisfaction of the Surveyor and, if it is considered necessary, they are to be tested.

12.1.6 The manoeuvring of the engines is to be tested under working conditions.

12.1.7 Exhaust steam turbines supplying power for main propulsion purposes in conjunction with reciprocating engines together with their gearing and appliances, steam compressors or electrical machinery, are to be examined, so far as practicable. Where cone connections to internal gear shafts are fitted, the coned ends are to be examined, so far as practicable.

12.1.8 In ships having essential auxiliary machinery driven by oil engines, the prime movers of these auxiliaries are to be examined as detailed in *Pt 1, Ch 3, 13 Reciprocating internal combustion engines - Detailed requirements*.

■ *Section 13*

Reciprocating internal combustion engines - Detailed requirements

13.1 Scope

13.1.1 The requirements of this Section are applicable to reciprocating internal combustion engines, operating on liquid, gas or dual fuel, providing power for services essential to the safety of the vessel.

13.2 Complete Surveys

13.2.1 The requirements of *Pt 1, Ch 3, 11 Machinery surveys - General requirements* are to be complied with.

13.2.2 The following parts are to be opened out and examined:

- Cylinders and covers.
- Pistons, piston rods, connecting rods, crossheads and guides.
- Valves and valve gear.
- Crankshafts and all bearings.
- Crankcases, bedplates and entablatures.
- Crankcase door fastenings, explosion relief devices and scavenge relief devices.
- Scavenge pumps, scavenge blowers, superchargers and their associated coolers.
- Air compressors and their intercoolers.
- Filters and/or separators and safety devices.
- Fuel pumps and fittings.
- Camshaft drives and balancer units.
- Vibration dampers or detuners.
- Flexible couplings and clutches.
- Reverse gears.
- Attached pumps and cooling arrangements.

13.2.3 Selected pipes in the starting air system are to be removed for internal examination and are to be hammer tested. If any appreciable amount of lubricating oil is found in the pipes, the starting air system is to be thoroughly cleaned internally by steaming out, or other suitable means. Some of the pipes selected are to be those adjacent to the starting air valves at the cylinders and to the discharges from the air compressors.

13.2.4 The electric ignition system, if fitted, is to be examined and tested.

13.2.5 The manoeuvring of engines is to be tested under working conditions. Initial starting arrangements are to be tested.

13.2.6 Where steam is used for essential purposes, the condensing plant, feed pumps and fuel oil burning plant are to be examined and the steam pipes examined and tested as detailed in *Pt 1, Ch 3, 16 Steam pipes*.

■ Section 14**Electrical equipment****14.1 Annual and Intermediate Surveys**

14.1.1 The electrical contacts of air circuit-breakers are to be visually inspected and maintained in accordance with the manufacturer's recommendations by suitably qualified and trained personnel. Appropriate maintenance records are to be made available to the attending Surveyor on request.

14.1.2 The requirements of *Pt 1, Ch 3, 2.2 Annual Surveys* and *Pt 1, Ch 3, 3.2 Intermediate Surveys* are to be complied with as far as applicable.

14.2 Complete Surveys

14.2.1 An electrical insulation resistance test is to be made on the electrical equipment and cables. The installation may be sub-divided, or equipment which may be damaged disconnected, for the purpose of this test.

14.2.2 The fittings on the main and emergency switchboard, section boards and distribution boards are to be examined and over-current protective devices and fuses inspected to verify that they provide suitable protection for their respective circuits.

14.2.3 Generator circuit-breakers are to be tested, so far as practicable, to verify that protective devices including preference tripping relays, if fitted, operate satisfactorily.

14.2.4 Air circuit-breakers for essential or emergency services and rated at 800 A and above are to be surveyed to ensure that the manufacturer's recommended number of switching options has not been exceeded. See *Pt 6, Ch 2, 7.3 Circuit-breakers 7.3.6*. Where a breaker is not fitted with an automatic counter, a written record is to be kept.

14.2.5 The electric cables are to be examined, so far as practicable, without undue disturbance of fixtures or casings, unless opening up is considered necessary as a result of observation or of the tests required by *Pt 1, Ch 3, 14.2 Complete Surveys 14.2.1*.

14.2.6 The generator prime movers are to be surveyed as required by *Pt 1, Ch 3, 12 Turbines and steam engines - Detailed requirements* and *Pt 1, Ch 3, 13 Reciprocating internal combustion engines - Detailed requirements* and the governing of the engines tested. The motors concerned with essential services together with associated control and switch gear are to be examined and, if considered necessary, are to be operated, so far as practicable, under working conditions. All generators and steering gear motors are to be examined and are to be operated under working conditions, though not necessarily under full load or simultaneously.

14.2.7 Where transformers associated with supplies to essential services are liquid-immersed, the Owner is to arrange for samples of the liquid to be taken and tested for dissolved gases, breakdown voltage, acidity and moisture by a competent testing authority, in accordance with the equipment manufacturer's requirements, and a certificate giving the test results is to be made available to the Surveyor on request.

14.2.8 Navigation light indicators are to be tried under working conditions, and correct operation on the failure of supply or failure of navigation lights is to be verified.

14.2.9 The emergency sources of electrical power, their automatic arrangements and associated circuits are to be tested.

14.2.10 Emergency lighting, transitional emergency lighting, supplementary emergency lighting, general emergency alarm and public address systems are to be tested as far as practicable.

14.2.11 Where the ship is electrically propelled, the propulsion motors, generators, propulsion transformers, propulsion conversion equipment, cables, harmonic filters, neutral earthing resistors, dynamic braking resistors and all ancillary electrical equipment that forms part of the propulsion drive and control system, exciters and ventilating plant (including coolers) associated therewith are to be surveyed, and the insulation resistance to earth is to be tested. Special attention is to be given to windings, commutators and slip-rings. Where practicable, the low voltage and high voltage windings of cast resin propulsion transformers are to be subjected to boroscopic inspection, to assess the physical condition of their insulation and for signs of mechanical and thermal damage. The operation of protective gear and alarm devices is to be checked, so far as practicable. Insulating oil, if used, is to be tested in accordance with *Pt 1, Ch 3, 14.2 Complete Surveys 14.2.7*. Interlocks intended to prevent unsafe operations or unauthorised access are to be checked to verify that they are functioning correctly. Emergency overspeed governors are to be tested.

14.2.12 A General Examination of the electrical equipment in areas which may contain flammable gas or vapour and/or combustible dust is to be made to ensure that the integrity of the safe-type electrical equipment has not been impaired owing to corrosion, missing bolts, etc. and that there is not an excessive build-up of dust on or in dust protected electrical equipment. Cable runs are to be examined for sheath and armouring defects, where practicable, and to ensure that the means of supporting the cables are in good order. Tests are to be carried out to demonstrate the effectiveness of bonding straps for the control of static electricity. Alarms and interlocks associated with pressurized equipment or spaces are to be tested for correct operation.

14.2.13 For ships having an **OPS** notation assigned, the onshore power supply arrangements are to be examined and functionally tested whilst connected to an external electrical power supply in accordance with approved test schedules (see *Pt 7, Ch 13 On-shore Power Supplies*) during the Complete Surveys of machinery or, where it is not practical to provide the facilities and operations for testing during the required Surveys of other machinery items, within 12 months of the due date of the Complete Surveys of machinery.

14.3 Docking Surveys

14.3.1 For tankers five years old and over, *Pt 1, Ch 3, 14.2 Complete Surveys 14.2.12* is to be complied with. In addition, an electrical insulation resistance test of the circuits terminating in, or passing through, the hazardous zones and spaces is to be carried out.

■ Section 15 Boilers

15.1 Frequency of surveys

15.1.1 All boilers, economizers, steam receivers, steam heated steam generators, thermal oil and hot water units intended for essential services, together with boilers used exclusively for non-essential services having a working pressure exceeding 3,5 bar and a heating surface exceeding 4,5 m² are to be surveyed internally. There is to be a minimum of two internal examinations during each five-year Special Survey cycle. The interval between any two such examinations is not to exceed 36 months. A general external examination is to be carried out at the time of the Annual Survey.

15.1.2 Consideration may be given in exceptional circumstances to an extension of the internal examination of the boiler not exceeding three months beyond the due date. The extension may be granted after the following is satisfactorily carried out:

- (a) External examination of the boiler.
- (b) Examination and operational test of the boiler safety valve relieving gear (easing gear).
- (c) Operational tests of the boiler protective devices.
- (d) Review of the following records since the previous boiler survey:
 - Operation
 - Maintenance
 - Repair history
 - Feedwater chemistry.

In this context 'exceptional circumstances' means unavailability of repair facilities, essential materials, equipment or spare parts, or delays incurred by action taken to avoid severe weather conditions.

15.1.3 An external survey of boilers including tests of safety and protective devices, and tests of safety valves using their relieving gear, is to be carried out annually within the range dates of the Annual Survey of the ship. For exhaust gas heated economizers, the safety valves are to be tested by the Chief Engineer at sea within the range dates of the Annual Survey. This test is to be recorded in the log book and reviewed by the attending Surveyor prior to crediting the Annual Survey.

15.2 Scope of surveys

15.2.1 At the surveys described in *Pt 1, Ch 3, 15.1 Frequency of surveys*, the boilers, superheaters, economizers and air heaters are to be examined internally on the water-steam side and the fire side. Where considered necessary, the pressure parts are to be tested by hydraulic pressure and the thicknesses of plates and tubes and sizes of stays are to be ascertained to determine a safe working pressure. The safety valves and principal mountings on boilers, superheaters and economizers are to be examined and opened up as necessary by the Surveyor. The adjustment of safety valves is to be verified during each boiler internal

survey. Boiler safety valves and their relieving gear are to be examined and tested to verify their satisfactory operation. Safety valves are to be set under steam to a pressure not greater than the approved design pressures of the respective parts. As a working tolerance, the setting is acceptable, provided that the valves lift at not more than 103 per cent of the approved design pressure. However, for exhaust gas heated economizers, if steam cannot be raised in port, the safety valves may be set by the Chief Engineer at sea, and the results recorded in the log book and reviewed by the attending Surveyor. The following records since the previous Boiler Survey are to be reviewed as part of the survey:

- Operation
- Maintenance
- Repair history
- Feedwater chemistry.

The remaining mountings are to be examined externally and, if considered necessary by the Surveyor, are to be opened up for internal examination. Collision chocks, rolling stays and boiler stools are to be examined and maintained in an efficient condition.

15.2.2 In addition to the foregoing, in exhaust gas heated economizers of the shell type, all accessible welded joints are to be subjected to a visual examination in order to identify any evidence of cracking. Non-destructive testing may be required for this purpose and may be requested by the Surveyor.

15.2.3 In fired boilers employing forced circulation, the pumps used for this service are to be opened and examined at each Boiler Survey.

15.2.4 The fuel oil burning system is to be examined under working conditions and a General Examination made of fuel tank valves, pipes, deck controlgear and oil discharge pipes between pumps and burners.

15.2.5 At each survey of a cylindrical boiler which is fitted with smoke tube superheaters, the saturated steam pipes are to be examined as detailed in Section 16.

15.2.6 At the annual General Examination referred to in *Pt 1, Ch 3, 15.1 Frequency of surveys 15.1.1* the requirements of *Pt 1, Ch 3, 2.2 Annual Surveys 2.2.14* to *Pt 1, Ch 3, 2.2 Annual Surveys 2.2.16* are to be complied with.

■ Section 16 Steam pipes

16.1 Frequency of surveys

16.1.1 Saturated steam pipes, as well as superheated steam pipes where the temperature of the steam at the superheater outlet is not over 450°C, are to be surveyed 10 years from the date of build (or installation) and thereafter at five-yearly intervals.

16.1.2 Superheated steam pipes where the temperature of the steam at the superheater outlet is over 450°C are to be surveyed five years from the date of build (or installation) and thereafter at five-yearly intervals.

16.1.3 At 10 years from the date of build (or installation) and thereafter at five-yearly intervals, all copper or copper alloy steam pipes over 76 mm external diameter supplying steam for essential services at sea, are to be hydraulically tested to twice the working pressure.

16.2 Scope of surveys

16.2.1 At each survey, a selected number of main steam pipes, also of auxiliary steam pipes, which:

- (a) are over 76 mm external diameter,
- (b) supply steam for essential services at sea, and
- (c) have bolted joints,

are to be removed for internal examination and are to be hydraulically tested to 1,5 times the working pressure. If these selected pipes are found satisfactory in all respects, the remainder need not be tested. So far as practicable, the pipes are to be selected for examination and hydraulic test in rotation, so that in the course of surveys all sections of the pipeline will be tested.

16.2.2 Where main and/or auxiliary steam pipes of the category described in *Pt 1, Ch 3, 16.2 Scope of surveys 16.2.1* and *Pt 1, Ch 3, 16.2 Scope of surveys 16.2.1* have welded joints between the lengths of pipe and/or between pipes and valves, the lagging in way of the welds is to be removed, and the welds examined and, if considered necessary by the Surveyor, crack

detected. Pipe ranges having welded joints are to be hydraulically tested to 1,5 times the working pressure. Where lengths having ordinary bolted joints are fitted in such pipe ranges and can be readily disconnected, they are to be removed for internal examination and hydraulically tested to 1,5 times the working pressure.

16.2.3 Where, on cylindrical boilers having smoke tube superheaters, the saturated steam pipes adjoining the saturated steam headers are situated partly in the boiler smoke boxes, all such pipes adjoining and cross-connecting these headers in the smoke boxes are, at the surveys required by *Pt 1, Ch 3, 16.1 Frequency of surveys*, to be included in the pipes selected for examination and testing, as defined in *Pt 1, Ch 3, 16.2 Scope of surveys 16.2.1*. Where the saturated steam pipes inside the smoke boxes consist of steel castings of substantial construction, these requirements need only be applied to a sample casting. Where steel castings are not fitted, the Surveyor is to satisfy himself of the condition of the ends of the saturated steam pipes in the smoke boxes at each Boiler Survey and, if he considers it necessary, a sample pipe is to be removed for examination.

16.2.4 At the surveys specified in *Pt 1, Ch 3, 16.1 Frequency of surveys 16.1.3*, any of the copper or copper alloy pipes, such as those having expansion or other bends, which may be subject to bending and/or vibration, also closing lengths adjacent to steam-driven machinery, are to be annealed before being tested.

16.2.5 Where it is inconvenient for the Owner to fulfill all the requirements of a Steam Pipe Survey at its due date, the Committee will be prepared to consider postponement of the survey, either wholly or in part.

■ Section 17 Screwshafts, tube shafts and propellers

17.1 Frequency of surveys

17.1.1 Shafts with keyed propeller attachments and fitted with continuous liners or approved oil glands, or made of approved corrosion resistant materials, are to be surveyed at intervals of five years when the keyway complies fully with the present Rules.

17.1.2 Shafts having keyless-type propeller attachments are to be surveyed at intervals of five years, provided they are fitted with approved oil glands or are made of approved corrosion resistant materials.

17.1.3 Shafts having solid coupling flanges at the after end are to be surveyed at intervals of five years, provided they are fitted with approved oil glands or are made of approved corrosion resistant materials.

17.1.4 All other shafts not covered by *Pt 1, Ch 3, 17.1 Frequency of surveys 17.1.1* to *Pt 1, Ch 3, 17.1 Frequency of surveys 17.1.3* are to be surveyed at intervals of 2¹/₂ years.

17.1.5 Controllable pitch propellers for main propulsion purposes are to be surveyed at the same intervals as the screwshaft.

17.1.6 Directional propeller and podded propulsion units for main propulsion purposes are to be surveyed at intervals not exceeding five years.

17.1.7 Water jet units for main propulsion purposes are to be surveyed at intervals not exceeding five years, provided the impeller shafts are made of approved corrosion resistant material or have approved equivalent arrangements.

17.1.8 Dynamic positioning and/or thruster-assisted mooring and athwartship thrust propellers and shaftings are to be surveyed at intervals not exceeding five years.

17.2 Normal surveys

17.2.1 All screwshafts are to be withdrawn for examination by LR's Surveyors at the intervals prescribed in *Pt 1, Ch 3, 17.1 Frequency of surveys 17.1.1* to *Pt 1, Ch 3, 17.1 Frequency of surveys 17.1.4*. The after end of the cylindrical part of the shaft and the forward one-third of the shaft cone, or fillet of the flange, are to be examined by a magnetic particle crack detection method. In the case of a keyed propeller attachment, at least the forward one-third of the shaft cone is to be examined with the key removed. Wear-down is to be measured and the sterntube bearings, oil glands, propellers and fastenings are to be examined. Controllable pitch propellers where fitted are to be opened up and the working parts examined, together with the controlgear.

17.2.2 Directional propeller and podded propulsion units, inclusive of the propellers, shafts, gearing, controlgear and the primary electrical components including any control and protection devices, are to be dismantled if considered necessary and generally examined as far as practicable.

17.2.3 Water jet units, including the impeller, casing, shaft, shaft seal, shaft bearing, inlet and outlet channels, steering nozzle, reversing arrangements, and controlgear are to be generally examined so far as practicable.

17.2.4 Dynamic positioning and/or thruster-assisted mooring and athwartship thrust propellers are to be generally examined so far as possible in dry dock and tested under working conditions afloat for satisfactory operation. All accessible parts, including sealing, locking and bearing faces, and any other moving parts are to be examined. Non-destructive examination is to be carried out as considered necessary by the Surveyor on blade/fin roots. Consideration may be given to condition monitoring schemes for determining the condition of the unit.

17.2.5 Podded propulsion unit screwshaft roller bearings are to be renewed when the calculated life at the maximum continuous rating no longer exceeds the survey interval. See *Pt 5, Ch 9, 6.3 Propulsion shafting 6.3.7*.

17.2.6 Stationary supporting structure and any erosion protection inserts or doublers are to be examined in way of any propulsion devices.

17.3 Screwshaft Condition Monitoring (SCM)

17.3.1 Monitoring records are to be reviewed at annual survey for all vessels assigned the ShipRight descriptive note SCM (Screwshaft Condition Monitoring). The records that are to be maintained for oil and water lubricated bearings are detailed in the following Sections.

17.3.2 Oil lubricated bearing records are to be available on board that include the following:

(a) Lubricating oil analysis to be carried out regularly at intervals not exceeding six months. Each analysis is to include the following minimum parameters:

- water content,
- chloride content,
- bearing material and metal particles content,
- oil ageing (resistance to oxidation) , minimum testing to include Viscosity and Total Acid Number (TAN).

Note Oil samples are to be taken under service conditions and are to be representative of the oil within the sterntube.

(b) Oil consumption.

(c) Bearing temperatures.

17.3.3 Further information is provided in the LR document *ShipRight Procedure Machinery Planned Maintenance and Condition Monitoring*.

17.3.4 Water lubricated bearing records are to be available on board that include the following:

- (a) A record of variations in the flow rate of lubricating water.
- (b) A record of variations in the shaft power transmission.
- (c) Wear monitoring records for the sternbush.
- (d) For open loop systems the records from equipment for continuous monitoring of water sediment or alternatively records from a LR approved extractive sampling and testing procedure are to be available on board.

Records of cleaning and replacement of lubrication filters/separators are to be maintained on board. The pumping and water filtration system is to be considered part of the continuous survey cycle and is to be subject to a Periodical Survey.

(e) For closed cycle water systems the records from water analysis results carried out regularly at intervals not exceeding six months are to be retained on board. The analysis is to include the following parameters:

- (i) Chloride content
- (ii) Bearing material and metal particles content.

Note Samples are to be taken under service conditions and are to be representative of the water circulating within the sterntube.

Note Records of cleaning and replacement of lubrication filters/separators are to be maintained on board. The pumping and water filtration system is to be considered part of the continuous survey cycle and is to be subject to a Periodical Survey.

17.3.5 For maintenance of the descriptive note **SCM**, the records of all data collected in *Pt 1, Ch 3, 17.3 Screwshaft Condition Monitoring (SCM) 17.3.2* and *Pt 1, Ch 3, 17.3 Screwshaft Condition Monitoring (SCM) 17.3.4* are to be retained on board and audited by LR annually.

17.3.6 Where the requirements for the descriptive note **SCM** have been complied with, the screwshaft need not be withdrawn at surveys as required by *Pt 1, Ch 3, 17.2 Normal surveys 17.2.1*, provided all condition monitoring data are found to be within permissible limits and all exposed areas of the shaft are examined by a magnetic particle crack detection method or an alternative approved means for shafts with a protective liner or coating *Pt 5, Ch 6, 4.1 Screwshaft Condition Monitoring (SCM) 4.1.3*. The

remaining requirements of *Pt 1, Ch 3, 17.2 Normal surveys 17.2.1* are to be complied with. Where the Attending Surveyor considers that the data presented is not sufficient to determine the condition of the shaft, the shaft may be required to be withdrawn in accordance with *Pt 1, Ch 3, 17.2 Normal surveys 17.2.1*. For water lubricated bearings, the screwshaft is to be withdrawn for examination, as *Pt 1, Ch 3, 17.2 Normal surveys 17.2.1*, when the ship reaches 18 years from the date of build or the third Special Survey, whichever comes first.

17.4 Modified Survey

17.4.1 A Modified Survey may be accepted at alternate five-yearly surveys for shafts described in *Pt 1, Ch 3, 17.1 Frequency of surveys 17.1.1*, provided they are fitted with oil lubricated bearings and approved oil glands, and also for those in *Pt 1, Ch 3, 17.1 Frequency of surveys 17.1.2* and *Pt 1, Ch 3, 17.1 Frequency of surveys 17.1.3*.

17.4.2 The Modified Survey is to consist of the partial withdrawal of the shaft, sufficient to ascertain the condition of the stern bearing and shaft in way. For keyless propellers or shafts with a solid flange connection to the propeller, a visual examination to confirm the good condition of the sealing arrangements is to be made. The oil glands are to be capable of being replaced without removal of the propeller. The forward bearing and all accessible parts, including the propeller connection to the shaft, are to be examined as far as possible. Wear down is to be measured and found satisfactory. Where a controllable pitch propeller is fitted, at least one of the blades is to be dismantled complete for examination of the working parts and the controlgear.

17.4.3 For keyed propellers, the after end of the cylindrical part of the shaft and forward one-third of the shaft cone is to be examined by a magnetic particle crack detection method, for which dismantling of the propeller and removal of the key will be required.

17.4.4 Where the requirements for the descriptive note **SCM** have been complied with, as described in *Pt 1, Ch 3, 17.3 Screwshaft Condition Monitoring (SCM) 17.3.1* and all data are found to be within permissible limits, partial withdrawal of the shaft will not be required. Where doubt exists regarding any of the above findings, the shaft is to be withdrawn to permit an entire examination.

17.5 Partial Survey

17.5.1 For shafts where the Modified Survey is applicable, upon application by the Owner, the Committee will be prepared to give consideration to postponement of the survey for a maximum period of half the specified cycle provided a Partial Survey is held.

17.5.2 The Partial Survey is to consist of the propeller being backed off in any keyed shaft and the top half of the cone examined by an efficient crack detection method for which the removal of the key will be required. On ships less than 15 years old, propellers with keyless connections to the screwshaft are not required to be backed off. Exposed areas of screwshaft, oil gland and seals are to be examined and dealt with as necessary. Wear down is to be measured, recorded and reviewed at each screwshaft survey and found satisfactory. Propeller and fastenings are to be examined.

17.5.3 The Committee will be prepared to give consideration to the circumstances of any special case upon application by the Owner.

■ Section 18 **Inert gas systems**

18.1 Frequency of surveys

18.1.1 Inert gas systems installed on board ships intended for the carriage of oil or liquid chemicals in bulk are to be surveyed annually in accordance with the requirements of *Pt 1, Ch 3, 2.2 Annual Surveys 2.2.32*. A Special Survey of the inert gas system, in accordance with the requirements of *Pt 1, Ch 3, 18.2 Scope of surveys*, is to be held at intervals not exceeding five years.

18.2 Scope of surveys

18.2.1 At each Special Survey of the inert gas system, the inert gas generator, scrubber and blower are to be opened out as considered necessary and examined. Gas distribution lines and shut-off valves, including soot blower interlocking devices are to be examined as considered necessary. The deck seal and non-return valve are to be examined. Cooling water systems including the effluent piping and overboard discharge from the scrubbers are to be examined. All automatic shutdown devices and alarms are to be tested. The complete installation is to be tested under working conditions on completion of survey.

18.2.2 When, at the request of an Owner, it has been agreed by the Committee that the Complete Survey of the inert gas systems may be carried out on the Continuous Survey basis, the various items of machinery are to be opened for survey in rotation, so far as practicable, to ensure that the interval between consecutive examinations of each item will not exceed five years. In general, approximately one-fifth of the machinery is to be examined each year.

18.2.3 If any examination during Continuous Survey reveals defects, further parts are to be opened up and examined as considered necessary by the Surveyors, and the defects are to be made good to their satisfaction.

18.2.4 See *Pt 1, Ch 3, 9.7 Special Survey I (ships five years old) – General requirements 9.7.12* for inert gas systems on ships for liquefied gases.

18.2.5 See *Pt 1, Ch 3, 23.3 Annual Surveys – General Requirements for Fuel Systems 23.3.5* and *Pt 1, Ch 3, 23.7 Intermediate Surveys 23.7.1* for inert gas systems on ships with natural gas fuel installations.

■ Section 19

Classification of ships not built under survey

19.1 General

19.1.1 When classification is desired for a ship not built under the supervision of LR's Surveyors, application should be made to the Committee in writing.

19.1.2 Periodical Surveys of such ships, when classed, are subsequently to be held as in the case of ships built under survey.

19.1.3 Where classification is desired for a ship which is classed by another recognized Society, special consideration will be given to the scope of the survey.

19.2 Hull and equipment

19.2.1 Plans showing the main scantlings and arrangements of the actual ship, together with any proposed alterations, are to be submitted for approval. These should comprise plans of the midship section, longitudinal section and decks, and such other plans as may be requested. If plans cannot be obtained or prepared by the Owner, facilities are to be given for LR's Surveyor to obtain the necessary information from the ship.

19.2.2 Particulars of the process of manufacture and the testing of the material of construction are to be supplied.

19.2.3 In all cases, the full requirements of *Pt 1, Ch 3, 5 Special Survey - General - Hull requirements, Pt 1, Ch 3, 6 Special Survey - Bulk carriers - Hull requirements, Pt 1, Ch 3, 7 Special Survey - Oil tankers (including ore/oil ships and ore/bulk/oil ships) - Hull requirements, Pt 1, Ch 3, 8 Special Survey - Chemical Tankers - Hull requirements, Pt 1, Ch 3, 9 Ships for liquefied gases and Pt 1, Ch 3, 10 Dredgers, hopper dredgers, sand carriers, hopper barges and reclamation craft* are to be carried out as applicable. Ships of recent construction will receive special consideration.

19.2.4 During the survey, the Surveyors are to satisfy themselves regarding the workmanship and verify the approved scantlings and arrangements. For this purpose, and in order to ascertain the amount of any deterioration, parts of the structure will require to be gauged as necessary. Full particulars of the anchors, chain cables and equipment are to be submitted. For ships to which *Pt 6, Ch 4 Fire Protection, Detection and Extinction Requirements* applies, fire protection, detection and extinction are to be in accordance with that Chapter. Loading instruments, where required, are to be in accordance with the Rules, see *Pt 3, Ch 3, 4.8 Watertight tunnels and passageways* as applicable.

19.2.5 When the full survey requirements indicated in *Pt 1, Ch 3, 19.2 Hull and equipment 19.2.3* and *Pt 1, Ch 3, 19.2 Hull and equipment 19.2.4* cannot be completed at one time, the Committee may consider granting an interim record for a limited period. The conditions regarding the completion of the survey will depend on the merits of each particular case, which should be submitted for consideration.

19.3 Machinery

19.3.1 To facilitate the survey, plans of the following items (plans of piping are to be diagrammatic), together with the particulars of the materials used in the construction of the boilers, air receivers and important forgings, are to be furnished:

- General pumping arrangements, including air and sounding pipes (Shipbuilder's plan).
- Pumping arrangements at the forward and after ends of oil tankers and drainage of cofferdams and pump rooms.

- General arrangement of cargo piping in tanks and on deck of oil tankers.
- Piping arrangements for cargo oil (F.P. 60°C or above, closed cup test).
- Bilge, ballast and fuel oil pumping arrangements in the machinery space, including the capacities of the pumps on bilge service.
- Arrangement and dimensions of main steam pipes.
- Arrangement of fuel oil pipes and fittings at settling and service tanks.
- Arrangement of fuel oil piping in connection with oil burning installations.
- Fuel oil and cargo oil overflow systems, where these are fitted.
- Arrangement of boiler feed systems.
- Fuel oil settling, service and other fuel oil tanks not forming part of the ship's structure.
- Boilers, superheaters and economizers.
- Air receivers.
- Crank, thrust, intermediate and screw shafting.
- Clutch and reversing gear with methods of control.
- Reduction gearing.
- Propeller (including spare propeller if supplied).
- Electrical circuits.
- Arrangement of compressed air systems for main and auxiliary services.
- Arrangement of lubricating oil systems.
- Arrangement of flammable liquids used for power transmission, control and heating systems
- Arrangement of cooling water systems for main and auxiliary services.
- General arrangement of cargo tank vents. The plan is to indicate the type and position of the vent outlets from any superstructure, erection, air intake, etc. Ventilation arrangements of cargo and/or ballast pump rooms and other enclosed spaces which contain cargo handling equipment.

19.3.2 Plans additional to those detailed in *Pt 1, Ch 3, 19.3 Machinery 19.3.1* are not to be submitted unless the machinery is of a novel or special character affecting classification.

19.3.3 Where remote and/or automatic controls are fitted to propulsion machinery and essential auxiliaries, a description of the scheme is to be submitted.

19.3.4 For new ships and ships which have been in service less than two years, calculations of the torsional vibration characteristics of the propelling machinery are to be submitted for consideration, as required for ships constructed under Special Survey. For older ships, the circumstances will be specially considered in relation to their service record and type of machinery installed. Where calculations are not submitted, the Committee may require that the machinery certificate be endorsed to this effect. When desired by the Owner, the calculations and investigation of the torsional vibration characteristics of the machinery may be carried out by LR upon special request.

19.3.5 The main and auxiliary machinery, feed pipes, compressed air pipes and boilers are to be examined as required at Complete Surveys. Working pressures are to be determined from the actual scantlings in accordance with the Rules.

19.3.6 The screwshaft is to be drawn and examined.

19.3.7 The steam pipes are to be examined and tested as required by *Pt 1, Ch 3, 16 Steam pipes*.

19.3.8 The bilge, ballast and fuel oil pumping arrangements are to be examined and amended, as necessary, to comply with the Rules.

19.3.9 Oil burning installations are to be examined as required at Complete Surveys and found, or modified, to comply with the requirements of the Rules; they are also to be tested under working conditions.

19.3.10 The electrical equipment is to be examined as required at Complete Surveys.

19.3.11 Where an inert gas system is fitted on ships intended for the carriage of oil in bulk having a flash point not exceeding 60°C, the requirements of *Pt 5, Ch 15, 7 Inert gas systems on Tankers of 8,000 tonnes DWT and above* apply.

19.3.12 The whole of the machinery, including essential controls, is to be tried under working conditions to the Surveyor's satisfaction.

19.3.13 First entry reports are to be prepared by the Surveyors.

19.4 Refrigerated cargoes

19.4.1 When classification is desired for an installation not constructed under the supervision of LR's Surveyors, application is to be made to the Committee in writing.

19.4.2 Full particulars and plans are to be forwarded for consideration, together with the particulars of the materials of the crankshafts, pressure vessels and pressure piping. The requirements of *Pt 6, Ch 3, 1 General requirements* and *Pt 6, Ch 3, 4 Refrigeration plant, pipes, valves and fittings* are to be used for guidance in regard to the information required.

19.4.3 A special examination is to be made at least to the extent required for subsequent Special Surveys, see *Pt 1, Ch 3, 20.3 Subsequent Special Survey*.

19.4.4 The thickness and material of the insulation, the particulars of the frames, beams, stiffeners and other steelwork within the insulation, the air coolers and/or chamber grid piping, the compressors, evaporators and condensers are to be verified so far as practicable.

19.4.5 The installation is to conform to the requirements of the relevant Sections of *Pt 6, Ch 3 Refrigerated Cargo Installations*.

19.4.6 Acceptance tests are to be carried out in accordance with the requirements of *Pt 6, Ch 3 Refrigerated Cargo Installations*.

■ Section 20 Refrigerated cargo installations

20.1 Annual Surveys

20.1.1 The Surveyors are to examine the machinery under working conditions as soon as practicable after a ship's arrival at a port of discharge before the cargo is unloaded. An examination of the refrigerated cargo installation log book (or other records) is to be made and any breakdowns or malfunctions of the plant during the previous twelve months are to be noted and reported to the Committee.

20.1.2 A General Examination of the refrigerating plant is to be carried out, and satisfactory operation of safety devices, controls and thermometry is to be verified. Insulated cargo spaces are to be inspected, and the condition of insulation, lining, scuppers, hatches, coolers, air ducting and air refreshing arrangements are to be checked. The Surveyors may request opening out of suspected items, or recommend repair or renewal of defective items, as a result of inspection.

20.1.3 A General Examination is to be made of electrical motors driving refrigerant compressors, pumps and fans, together with their controlgear and cables. Random tests for insulation resistance are to be made on the cables, switchgear, motors, etc. and this resistance is to be not less than 1 MΩ between individual conductors and between those conductors and earth. The installation may be subdivided for the purpose of this test, and the Surveyor may at his discretion accept the results of tests carried out by a competent member of staff or contractor.

20.1.4 A survey book or other permanent record is to be kept on board the ship to show the date of examination of the various parts. This is to be available to the Surveyor at all times, and is to be signed by the Surveyor on the occasion of each survey.

20.2 Special Surveys

20.2.1 At the first Special Survey, the examinations outlined below are to be carried out. Where there is a programme of replacement instead of maintenance on board, alternative survey arrangements will be considered. Each case will be given individual consideration.

20.2.2 Detailed internal examination of each reciprocating compressor, opened up for inspection of cylinders, pistons, connection rods, valves, seats, glands, relief devices, filters, lubrication and crankshaft.

20.2.3 For screw-type compressors, the period before opening up may be extended to six years or 25 000 running hours, whichever is the earlier. Examination should be made of rotors, clearances, gearing, etc.

20.2.4 Refrigerant condenser cooling water pumps, including standby pump(s) which may be used on other services, are to be opened up and their working parts exposed.

20.2.5 Primary and secondary refrigerant pumps are to be opened up and their working parts exposed.

20.2.6 The water end covers of condensers are to be removed for examination of the tubes, tubeplates and covers.

20.2.7 In the case of pressure vessels covered by insulation, any evidence of dampness or deterioration of the insulation which could lead to external corrosion of the vessels or their connections is to be investigated.

20.2.8 Sufficient insulation is to be stripped from insulated pressure vessels to allow the condition of the vessels and their connections to be ascertained. Care is to be taken that in replacement of the insulation, the vapour sealing of the outer covering is made good.

20.2.9 Sufficient insulation is to be stripped from pipes carrying the refrigerant at various points of the system both outside and inside the insulated chambers to permit the condition of the pipes to be ascertained. Sections of piping exposed are to include locations where lengths of piping have been connected by screwed couplings or butt welding. Care is to be taken that when ungalvanized portions of the piping in way of joints have been exposed, they are to be suitably coated and taped, after pressure testing, to prevent corrosion. On replacement of the insulation, the vapour sealing of the outer covering is to be made good.

20.2.10 A General Examination is to be made of all pressure relief valves and/or safety discs throughout the refrigerating plant to ensure that they are in good order and covered by current certification. However, no attempt is to be made to test primary refrigerant pressure relief on board ship. Relief valves are to be removed, overhauled and recalibrated every five years or in accordance with the manufacturer's recommendations, whichever is sooner.

20.2.11 Sea connections to refrigerant condenser cooling water pumps are to be opened up on the occasion of the hull and/or main machinery Special Survey.

20.2.12 The electric motors driving refrigerant compressors, pumps and fans, together with their controlgear and cables, are to have their insulation resistance tested and this is to be not less than 1 MΩ between individual conductors and between those conductors and earth. The installation may be subdivided to any desired extent by opening switches, removing fuses or disconnecting appliances for the purpose of this test.

20.2.13 All automatic controls, alarms and safety systems are to be tested and correct operation confirmed.

20.2.14 Sufficient air ducting and insulation lining is to be stripped from the cargo spaces or chamber's overhead and vertical surfaces to allow the condition of the insulation, insulation linings, grounds, supports, hangers and fixtures which support the insulation, grids, meat rails, etc. to be ascertained. Care is to be taken that on replacement, the ducts and linings are sealed against air blowing into the insulation, or against moisture ingress from refrigerated cell or space atmosphere.

20.2.15 Sufficient tank top insulation is to be stripped to allow the condition of the grounds and inner insulation lining to be ascertained.

20.2.16 Due consideration is to be given to the type of insulation used in the cargo spaces and chambers when determining the amount of insulation lining to be removed. Where organic foam insulants have been used, including panel systems or foamed *in situ*, or other insulants in slab form, the removal of panels or linings is to be at the Surveyor's discretion.

20.2.17 Under normal circumstances, the condition of the cargo space and chamber insulation, grounds, etc. can be ascertained when the Special Survey of the ship's steel structure is being held.

20.2.18 Arrangements made for defrosting air coolers, and for draining condensate from trays below coolers, are to be examined to ascertain that they are in working order. Trace heating elements around drain pipes should be specially examined.

20.2.19 Any air refreshing arrangements are to be examined.

20.3 Subsequent Special Survey

20.3.1 A subsequent Special Survey is to be held approximately five years from the date of the previous Special Survey. Where a Continuous Survey procedure has been agreed, the interval between consecutive examinations of each item should not exceed five years.

20.3.2 In addition to the requirements for the first Special Survey as detailed in *Pt 1, Ch 3, 20.2 Special Surveys* and *Pt 1, Ch 3, 20.3 Subsequent Special Survey 20.3.3* are to be complied with.

20.3.3 'Shell-and-tube' condensers and evaporators (secondary refrigerant coolers) in which the primary refrigerant is in the shell, are to have the shell pneumatically tested with the refrigerant, or air, or a mixture of inert gas and refrigerant (with the end covers removed) at pressures as stated in *Pt 6, Ch 3, 2.5 Design pressures 2.5.5*.

20.3.4 Shell-and-tube evaporators (secondary refrigerant coolers) in which the secondary refrigerant is in the shell are to have the shell hydraulically tested (with the end covers removed) to 1,5 times the design pressure, but in no case less than 2,9 bar g. After refitting the end covers, the primary refrigerant side is to be pneumatically tested as stated in *Pt 1, Ch 3, 20.3 Subsequent Special Survey 20.3.3*, and an examination made as far as practicable for gas leakage in the shell with the secondary refrigerant connection removed.

20.3.5 Heat exchangers used for cooling refrigerant liquid by the suction return gas to a compressor are not subject to internal corrosion, and would normally require to be specially examined internally only if leakage is suspected between high and low pressure sides. This type of heat exchanger, together with others using brine or water, are to be examined and tested at the discretion of the Surveyor according to the design of such equipment.

20.4 Loading Port Surveys

20.4.1 When a Loading Port Certificate is required by the Owner or his representative, a survey as detailed in *Pt 1, Ch 3, 20.4 Loading Port Surveys 20.4.2 to Pt 1, Ch 3, 20.4 Loading Port Surveys 20.4.7* is to be carried out at the loading port. The certificate is not in respect of the cargo to be loaded or the manner in which it is to be stowed.

20.4.2 The refrigerating installation is to be examined under working conditions, and the temperatures in the cargo chambers are to be noted.

20.4.3 A General Examination of the generating plant supplying electric power to the refrigerated cargo installation is to be carried out to confirm that it complies with *Pt 6, Ch 3, 6.1 General*.

20.4.4 The refrigerated cargo spaces and chambers are to be examined in an empty state to ascertain that they are clean and free from odour which may adversely affect the cargo to be loaded, that the air cooler coils and cooling grids and their connections are free from leakage, that cargo battens, where fixed to the vertical surfaces, are in good order, that cargo gratings or dunnage battens (see *Pt 6, Ch 3 Refrigerated Cargo Installations*) are available as necessary for the floors or decks, and that no damage has been sustained to the insulation or its lining prior to the loading of the refrigerated cargo. Any indications of defective insulation not considered to warrant immediate attention are to be noted and specially reported.

20.4.5 All scuppers and bilge suction drains draining insulated spaces are to be examined to ensure that they are in good working order, and that any liquid seals are primed.

20.4.6 If the ship loads at more than one port, one survey only at the first loading port will be required, provided that it includes the examination of all spaces or chambers which are to be used for refrigerated cargo during the voyage, and that general cargo is not subsequently carried in any of the spaces or chambers prior to loading the refrigerated cargo.

20.4.7 In the case of ships engaged on voyages of less than two months' duration, a Loading Port Certificate will be considered as valid for two months, provided that the cargoes carried are of such a nature as not to damage the insulation or appliances in the insulated chambers, nor to affect, by taint or mould, the refrigerated cargoes loaded during that period. For longer voyages, the certificate is valid for only one cargo from the loading port(s) to the discharge port(s).

20.4.8 If there is no LR Surveyor available at the loading port(s), or if none is obtainable from a port within a reasonable distance, the Committee will accept the report of a survey held at the loading port by two competent engineers of the ship.

20.5 Refrigerating plant on ships not classed with LR

20.5.1 In the case of refrigerating installations being constructed under Special Survey on ships not intended to be classed with LR, the installation is to comply with the applicable requirements of *Pt 6, Ch 3 Refrigerated Cargo Installations*.

20.5.2 The generator engines and electrical equipment, which supply power to the refrigerating installations are to be constructed in accordance with the requirements of the Classification Society concerned and the installation is also to comply with the requirements of *Pt 6, Ch 3, 6.1 General 6.1.2*. Such plant is to be examined generally and under working conditions by the Surveyors.

■ Section 21 Controlled atmosphere systems

21.1 Retention of class

21.1.1 It is a prerequisite of the **CA** notation that the refrigeration installation on board already conforms to a **⊗ Lloyd's RMC** class notation. see *Pt 1, Ch 2, 2.6 Class notations (refrigerated cargo installations (RMC), controlled atmosphere (CA) systems and carriage of refrigerated containers (CRC)) 2.6.1*.

21.1.2 For the retention of Class, the CA systems are to be submitted for Periodical Surveys by LR's Surveyors as specified in *Pt 1, Ch 3, 21.2 Annual Surveys* and *Pt 1, Ch 3, 21.3 Special Surveys*.

21.2 Annual Surveys

21.2.1 Annual Surveys are to be carried out from the date of the Initial Classification Survey to verify that the CA system remains satisfactory.

21.2.2 The complete CA installation is to be visually examined and tested for the following main aspects:

- (a) CA zone sealing arrangements including cleats and hinges, pressure/vacuum (P/V) valves, door locks, ventilation of adjacent spaces, warning notices.
- (b) CA zones to be individually tested for airtightness to the design pressure. Testing by ship's staff, within one month prior to the survey may be accepted, based on a written report by the Master subject to visual inspection confirming the airtightness.
- (c) Operation and performance testing of the gas supply equipment, including controls, alarms, interlocks, safety devices.
- (d) Ventilation arrangements including fans.
- (e) Electrical supply arrangements.
- (f) Gas analyzers and analyzing equipment and calibration.
- (g) RH sensors and calibrations.
- (h) Permanent and portable gas monitoring, calibration and personnel safety equipment.
- (i) Witnessing of the air leakage.
- (j) Voyage logs, records of CA zone airtightness and calibration of instruments.
- (k) Verification that an Operating and Safety Manual is on board, is complete and that the responsible officers have countersigned to confirm that they are familiar with its contents.

21.2.3 On satisfactory completion of this survey, a new Annual Survey 'AS', with date, will be assigned.

21.3 Special Surveys

21.3.1 Special Surveys are to be carried out at intervals of five years from the date of the Initial Classification Survey to verify that all machinery, CA zones and safety arrangements remain satisfactory. On request from Owners, all surveyable items may be examined on a continuous basis. With this option, 20 per cent of all items are to be presented for survey annually.

21.3.2 Each CA zone is to be subjected to an airtightness test.

21.3.3 The extent of dismantling is to be at the LR Surveyor's discretion, but is to be sufficient for the Surveyor to be satisfied as to the condition of the installation.

21.3.4 On satisfactory completion of this survey, a new Special Survey 'SS', or 'RMC CS' with date, will be assigned.

■ *Section 22*

Bow, inner, side shell and stern doors on Ro-Ro ships**22.1 General**

22.1.1 The requirements of *Pt 1, Ch 3, 2 Annual Surveys - Hull and machinery requirements to Pt 1, Ch 3, 5 Special Survey - General - Hull requirements* are to be complied with, as applicable.

22.1.2 The requirements in this Section are applicable to the survey of bow, inner, side shell and stern doors on roll on-roll off passenger (Ro-Pax) ships and roll on-roll off (Ro-Ro) cargo ships.

22.1.3 Annual Survey and Special Survey of bow, inner, side shell and stern doors are to include examinations, tests and checks to a sufficient extent in order to verify that they are in satisfactory condition, remain in compliance with applicable requirements, and are subject to proper maintenance and operation in accordance with the Operation and Maintenance Manual (OMM) or manufacturer's recommendations.

22.2 Definitions

22.2.1 For the application of the requirements in this Section, a **Ro-Ro ship** is a ship that utilises a loading ramp to enable wheeled vehicles to be rolled on and rolled off the ship.

22.2.2 A **Ro-Pax ship** is a passenger ship with Ro-Ro spaces or special category spaces.

22.2.3 **Ro-Ro spaces** are those that extend over a substantial length or the entire length of the ship, and are not normally sub-divided. These spaces can be loaded and unloaded (normally in a horizontal direction) with motor vehicles with fuel in their tanks for their own propulsion and/or goods (either packaged or in bulk, in rail or road cars (including tankers), trailers, containers, pallets, demountable tanks or in other stowage units or receptacles).

22.2.4 **Special category spaces** are enclosed vehicle spaces (above or below the bulkhead deck) that vehicles can be driven on to and from, and that can be accessed by passengers. Special category spaces may be accommodated on more than one deck, provided that the total overall clear height for vehicles does not exceed 10 m.

22.2.5 **Securing devices** are used to keep the door closed by preventing it from rotating about its hinges.

22.2.6 **Supporting devices** are used to transmit external or internal loads from the door to a securing device and from the securing device to the ship's structure, or a device other than a securing device, such as a hinge, stopper or other fixed device, that transmits loads from the door to the ship's structure.

22.2.7 A **locking device** is used to lock a securing device in the closed position.

22.2.8 A **Close-up Survey** is defined in *Pt 1, Ch 3, 1.5 Definitions*.

22.3 Annual Surveys

22.3.1 The survey is to consist of an examination to verify, as far as is practicable, that the bow, inner, side shell and stern doors are maintained in a satisfactory condition.

22.3.2 The Surveyor is to obtain confirmation that no unapproved changes have been made to the bow, inner, side shell and stern doors since the last survey.

22.3.3 Where applicable, Surveyors are to verify that the Operation and Maintenance Manual (OMM), including any revisions, is available on board. It is to be verified that documented operating procedures for closing and securing the doors are kept on board and posted at the appropriate place(s). The Surveyor is to apply particular attention to the register of inspections and its contents (contained within the OMM) as a basis for the survey.

22.3.4 An examination of the bow, inner, side shell and stern doors is to be carried out, with particular attention to be applied to the following:

- (a) The structural arrangement of doors, including plating, secondary stiffeners, primary structure, hinging arms and weld connections;
- (b) Shell structure surrounding the opening of the doors and the securing, supporting and locking devices, including shell plating, secondary stiffeners, primary structure and associated weld connections;
- (c) Hinges and bearings, thrust bearings;
- (d) Hull and door side supports for securing, supporting and locking devices.

Note If a crack is identified, an examination by non-destructive testing is to be carried out in the surrounding area and for similar items, as considered necessary by the Surveyor.

22.3.5 A Close-up Survey of the securing, supporting and locking devices is to be carried out. As a minimum, the Close-up Survey is to include the following:

- (a) Cylinder securing pins, supporting brackets, back-up brackets (where fitted) and their weld connections;
- (b) Hinge pins, supporting brackets, back-up brackets (where fitted) and their weld connections;
- (c) Locking hooks, securing pins, supporting brackets, back-up brackets (where fitted) and their weld connections;
- (d) Locking pins, supporting brackets, back-up brackets (where fitted) and their weld connections;
- (e) Locating and stopper devices and their weld connections.

22.3.6 The clearances of hinges, bearings and thrust bearings are to be measured where no dismantling is required. If the function test is not satisfactory, dismantling may be required to measure the clearances. If dismantling is carried out, a visual examination of hinge pins and bearings, together with non-destructive testing of the hinge pin, is to be carried out. The clearances of the securing, supporting and locking devices are to be measured, where indicated in the Operation and Maintenance Manual (OMM).

22.3.7 An examination of the sealing arrangements, including packing material/rubber gaskets, retaining bars or channels and associated weld connections, is to be carried out.

22.3.8 An examination of the drainage arrangements, including bilge wells and drain pipes, where fitted, is to be carried out. A test of the bilge system between the inner and outer doors is to be carried out.

22.3.9 A function test of doors is to be carried out. The Surveyor is to check the satisfactory operation of the bow, inner, side shell and stern doors during a complete opening and closing operation including, as applicable:

- (a) Proper working of the hinging arms and hinges;
- (b) Proper engagement of the thrust bearings;
- (c) Device for locking the door in the open position;
- (d) Securing, supporting and locking devices;
- (e) Proper sequence of the interlock system for the opening/ closing system and the securing and locking devices;
- (f) Mechanical lock of the securing devices;
- (g) Proper locking of hydraulic securing devices in the event of a loss of the hydraulic fluid, according to the procedure contained in the Operation and Maintenance Manual (OMM);
- (h) Correct indication of open/closed position of doors and securing/locking devices at navigation bridge and other control stations;
- (i) Isolation of the hydraulic securing/locking devices from other hydraulic systems;
- (j) Confirmation that the operating panels are inaccessible to unauthorised persons;
- (k) Verification that a notice plate giving instructions to the effect that all securing devices are to be closed and locked before leaving harbour is placed at each operating panel and supplemented by warning indicator lights;
- (l) Examination of electrical equipment for opening, closing and securing the doors.

22.3.10 A function test of the indicator system is to be carried out. The Surveyor is to check the satisfactory operation of the indicator system, where fitted, including the following, as applicable:

- (a) Proper visible indication and audible alarm on the navigation bridge panel, according to the selected function 'harbour/sea voyage' and on the operating panel;
- (b) Lamp test function on both panels;
- (c) Verification that it is not possible to turn off the indicator light on both panels;
- (d) Verification of fail safe performance, according to the procedure contained in the Operation and Maintenance Manual (OMM);
- (e) Confirmation that power supply for the indicator system is supplied by the emergency source or other secure power supply and is independent of the power supply for operating the doors;
- (f) Proper condition of sensors and protection from water, ice formation and mechanical damage.

22.3.11 A test of the water leakage detection system, where fitted, is to be carried out. The test is to include verification of a proper audible alarm on the navigation bridge panel and on the engine control room panel, according to the procedure contained in the Operation and Maintenance Manual (OMM).

22.3.12 A test of the television surveillance system, where fitted, is to be carried out. The test is to include verification of a proper indication on the navigation bridge monitor and on the engine control room monitor.

22.3.13 A hose test, or equivalent, is to be carried out. If the results of the visual examination and function test are satisfactory, the tightness test need not be carried out unless considered necessary by the Surveyor.

22.3.14 Following the visual examinations and function tests, non-destructive testing and thickness measurements may be required as considered necessary by the Surveyor.

22.4 Special Surveys

22.4.1 The requirements of *Pt 1, Ch 3, 22.3 Annual Surveys* are to be complied with as applicable.

22.4.2 The securing, supporting and locking devices, including their weld connections, are to be subjected to non-destructive testing and thickness measurement to the extent considered necessary by the Surveyor. The maximum allowable diminution is 15 per cent of the as-built thickness.

22.4.3 The effectiveness of the sealing arrangements is to be verified by carrying out a hose test, or equivalent.

22.4.4 The clearances of hinges, bearings and thrust bearings are to be measured. Unless otherwise specified in the Operation and Maintenance Manual (OMM), or by the manufacturer's recommendation, the measurement of clearances may be limited to representative bearings where dismantling is needed in order to measure the clearances. If dismantling is carried out, a visual examination of hinge pins and bearings, together with non-destructive testing of the hinge pin, is to be carried out.

22.4.5 The non-return valves of the drainage system are to be dismantled and examined.

■ Section 23

Natural gas fuel Installations

23.1 General

23.1.1 The requirements of *Pt 1, Ch 3, 11 Machinery surveys - General requirements* are to be complied with, as applicable.

23.1.2 In addition to the survey requirements below, further survey requirements may be imposed; as identified during the risk assessment process, see *Pt 1, Ch 2, 3.6 Surveys for novel/complex systems, machinery and equipment*

23.1.3 This Section provides requirements for the survey of natural gas fuel installations as defined in *Pt 1, Ch 3, 1.5 Definitions 1.5.29* (natural gas is hereinafter referred to as fuel).

23.1.4 The fuel installation is to be surveyed in working condition except at special survey where internal examination of some components will be required. See *Pt 1, Ch 3, 23.8 Complete Surveys – General requirements* and *Pt 1, Ch 3, 23.9 Complete Surveys – Natural gas fuelled consumers and other equipment*.

23.1.5 The Annual Survey should be scheduled, if possible, to coincide with a bunkering operation to allow for verification of fuel storage tank level alarms and bunkering control, alert and safety systems under operational conditions. At annual survey physical testing of alarms and shutdowns is not required unless it is considered necessary by the attending Surveyor. In any case records of the alarms are to be retained for the verification of the attending Surveyor.

23.1.6 The Intermediate Survey supplements the Annual Survey by testing the fuel bunkering system including automatic control, alert and safety systems to confirm satisfactory operation. The extent of the testing required for the Intermediate Survey may briefly interrupt the fuel installation and therefore vessel operations and the survey are to be scheduled accordingly.

23.1.7 The extent of the testing required for Complete Surveys will normally be such that the full survey cannot be carried out with the fuel installation operating or loaded with fuel. Consequently, aspects of the survey should be coordinated to correspond with dry-docking or another period when the system will be gas free. Completion of the survey requires verification of satisfactory condition of the installation at the normal operating temperatures and pressures so will normally be completed once the vessel has been bunkered following reactivation of the system.

23.1.8 Prior to any internal inspection of fuel storage tanks, associated piping, fittings and equipment, etc. the respective items are to be made safe for access by means of isolating relevant valves, purging and gas-freeing the space.

23.1.9 Where an approved condition-monitoring system is employed for the fuel system and its constituent components, and the applicable Descriptive Note is assigned, the requirements of these regulations for opening up and internal examination may be waived where the condition of the equipment can be shown to be within agreed acceptable limits as detailed in *Pt 5, Ch 21 Requirements for Condition Monitoring Systems and Machinery Condition-Based Maintenance Systems*.

23.1.10 The following documentation, as applicable, is to be available on board the ship:

- (a) Relevant instruction and information such as loading limit curve information, bunkering procedures, cooling down procedures and fuel installation test and inspection procedures.
- (b) Condition-Monitoring or Condition-Based Maintenance documentation as applicable.
- (c) Test records for bunkering ESD systems.
- (d) Records of crew tests/inspections of the fuel installation.

23.1.11 For Special Survey requirements for electrical equipment see *Pt 1, Ch 3, 14 Electrical equipment*.

23.1.12 Where the design of any part of the natural gas fuel system does not permit opening up for internal examination, as required by these regulations, alternative arrangements for testing and/or inspection will be specially considered.

23.2 Survey Following Repair

23.2.1 Following repair, independent fuel storage tanks of Type C are to be hydrostatically tested in accordance with the manufacturer's test and inspection instructions (normally at 1,25 times the approved maximum vapour pressure). Other types of fuel storage tank, such as membrane tanks, are to be tested in accordance with approved procedures provided by the fuel storage tank designers. After testing, suitable drying and consequent air-purging procedures are to be followed to return the tank to operational condition.

23.3 Annual Surveys – General Requirements for Fuel Systems

23.3.1 The Annual Survey is to be carried out with the fuel installation operational. Gas-freeing will not generally be necessary.

23.3.2 The ship's log and operational records for the fuel installation, covering the period from the previous survey, are to be examined. Any malfunction of the installation recorded in the log is to be investigated. It is to be verified that any repairs have been carried out to an acceptable standard and in accordance with the applicable Rules and Regulations.

23.3.3 Control, alert and safety systems are to be surveyed as follows:

- (a) The control, alert and safety systems for the fuel storage tanks and processing system are to be verified in satisfactory condition by one or more of the following methods:
 - (i) Comparison of read-outs from local and remote indicators.
 - (ii) Consideration of read-outs with regard to the actual conditions.
 - (iii) Examination of maintenance records with reference to the approved maintenance management system.
 - (iv) Verification of calibration status of the measuring instruments.
- (b) All control, alerts and safety systems are to be tested, where testing is not possible due to operational reasons simulated testing may be accepted by the attending Surveyor. Which are to include but are not limited to:
 - (i) fuel storage tank and processing system high and low pressure.
 - (ii) fuel storage tank high and high-high level
 - (iii) fuel storage tank overfill level
 - (iv) fuel storage tank high temperature.
- (c) Fuel leakage detection systems (temperature sensors and gas detection as applicable) are to be examined and tested in accordance with the manufacturer's instructions and calibrated using sample gas.
- (d) The electrical installation, equipment and cables in areas which may contain flammable gas are to be examined in order to verify that they are in good condition and have been properly maintained. Bonding straps that are installed to control static electricity are to be visually examined.
- (e) Alerts and safety systems associated with pressurised installations and any safety device associated with non-safe type electrical equipment that is protected by air-locks or pressurisation, are to be verified.

23.3.4 Fuel installations are to be surveyed as follows:

- (a) Portable and/or fixed drip trays, or insulation providing protection in the event of fuel leakage, are to be examined.
- (b) Components of the fuel installation fitted with insulation to provide protection against ice formation are to be examined for satisfactory condition.
- (c) Fuel piping, valves and fittings are to be generally examined, with particular attention to double-wall or ventilated ducting arrangements, expansion bellows, supports and vapour seals on insulated piping.

23.3.5 Inerting arrangements and associated alarms are to be verified as being in satisfactory condition, including the means for prevention of backflow of fuel vapour to the inert gas system.

23.3.6 Ventilation systems are to be surveyed as follows:

- (a) Ventilation systems and air-locks including their alarm system are to be generally examined.
- (b) Ventilation fans in hazardous areas are to be visually examined.
- (c) For ventilated double-walled piping or ducting containing fuel piping within machinery spaces, exhaust fans and/or supply fans are to be examined to ensure that the air-flow is not impeded.
- (d) Fuel piping and components associated with the fuel processing equipment are to be visually examined.

23.3.7 The closing devices for all air-intakes and openings into accommodation spaces, service spaces, machinery spaces, control stations and approved openings in superstructures and deckhouses less than 10m from deck-mounted fuel storage tanks, are to be examined.

23.3.8 Venting arrangements, including protection screens if provided, for fuel storage tanks, inter-barrier spaces and tank hold spaces as applicable, are to be visually examined externally. The external condition of the fuel storage tank relief valves is to be verified and records of the last test of the opening/closing pressures are to be reviewed.

23.3.9 Means for draining the vent arrangements from fuel storage tank pressure relief valves and other system relief valves are to be examined to ensure that there is no liquid build-up that would impede effective operation, drain valves are to be checked as applicable.

23.3.10 Heating arrangements, if fitted, for steel structures in cofferdams and other spaces are to be verified in satisfactory condition.

23.3.11 All gastight bulkhead penetrations, including any gastight shaft seals, are to be visually examined.

23.4 Annual Surveys – Fuel Processing Equipment

23.4.1 The following fuel processing equipment is to be generally examined in working condition and operational parameters verified. Insulation, where fitted, need not be removed but any deterioration of insulation, or evidence of dampness which could lead to external corrosion of the vessels or their connections, is to be investigated:

- (a) Heat exchangers and pressure vessels.
- (b) Natural gas fuel heaters, vaporisers, masthead heaters.
- (c) Heating arrangements, including provision for continuous heating and circulation of heating medium to prevent freezing during start up and when the fuel installation is not in use.
- (d) Fuel piping and components associated with the fuel processing equipment.

23.4.2 Where the double wall or duct containing fuel piping is protected using a pressurised inert gas atmosphere the monitoring and maintenance of the inert atmosphere is to be confirmed in satisfactory condition.

23.4.3 The condition of the fuel isolation valve and double block and bleed arrangements for each consumer is to be examined with respect to:

- (a) Containment to prevent fuel leakage from any valve arrangements installed within the machinery space.
- (b) Connections to the inerting and venting arrangements.
- (c) General examination to confirm that the valve arrangement and all associated fuel monitoring and control equipment are in satisfactory condition. The external examination is to be supplemented by a review of relevant operational, maintenance and service reports.

23.4.4 Where fuel processing equipment is located within an independent space that functions as containment in the event of a fuel spill (e.g. a tank connection space), the space is to be examined internally and externally to verify that the structure remains in a satisfactory condition to contain any potential leakage of fuel including any thermal isolation to protect the surrounding structure from damage due to cryogenic leakage.

23.4.5 Records of testing the operation of the tank master isolation valve are to be verified. Tests are to be carried out on regular basis as agreed with LR and the scope of the testing should incorporate a full test of the Emergency Shutdown sequence. Where possible, operation of the valve as described above is to be witnessed at the time of survey.

23.5 Annual Surveys – Fuel Storage

23.5.1 Areas in which fuel storage tanks are located (on and below deck) are to be examined for any changes to the arrangements within those areas that may affect the hazardous area rating.

23.5.2 For Type C pressurised fuel storage tanks the external surface of the fuel storage tank insulation is to be visually examined for cold spots to verify the condition of the insulation arrangements. This examination is to be carried out with the fuel storage tanks loaded. Ideally fuel storage tanks should be loaded to the maximum loading limit; examination of partially-filled fuel storage tanks may be accepted alongside a review of records of periodic cold spot examinations carried out by suitably trained and qualified crew.

23.5.3 The supporting structure between the deck plating and the tank is to be examined to confirm that the saddle arrangement remains in satisfactory condition in accordance with the approved design.

23.5.4 For vacuum-insulated fuel storage tanks, monitoring records are to be reviewed to confirm satisfactory maintenance of the vacuum. Any trends identifying a breakdown or loss of vacuum containment are to be investigated.

23.5.5 For Type B fuel storage tanks where the insulation arrangements are such that the insulation cannot be examined, the surrounding structures of wing tanks, double bottom tanks and cofferdams are to be visually examined for cold spots. This examination is to be carried out with the fuel storage tanks loaded. Ideally fuel storage tanks should be loaded to the maximum loading limit; examination of partially-filled fuel storage tanks may be accepted alongside a review of records of periodic cold spot examinations carried out by suitable trained and qualified crew.

23.5.6 For membrane fuel storage tanks the performance of the insulation arrangements is to be confirmed in accordance with approved procedures submitted by the containment designers.

23.6 Annual Survey - Fuel Bunkering System

23.6.1 The fuel-bunkering system, including manifold connections, isolation valves, bunker piping and linked Emergency Shutdown (ESD) system connection equipment (including cabling and connectors), are to be visually examined.

23.6.2 Bunkering operations are to be observed as far as possible; satisfactory condition of the bunkering control, alert and safety system is to be verified. During annual survey it is not expected that ESD1 (stoppage of bunker transfer) or ESD2 (disconnection of bunker piping) will be operationally tested but records of maintenance and testing are to be reviewed. However, prior to starting the bunkering operation, it is expected that an ESD1 is tested with no LNG in the system (i.e. a dry test). Records of the testing are to be available during survey.

23.7 Intermediate Surveys

23.7.1 In addition to the requirements below, the requirements of *Pt 1, Ch 3, 23.1 General* to *Pt 1, Ch 3, 23.6 Annual Survey - Fuel Bunkering System* are to be complied with.

- (a) Control, alert and safety systems for the bunkering system, fuel-containment systems and processing equipment, together with any associated shutdown and/or interlock, are to be tested under working conditions and, if necessary, recalibrated. Shutdown sequence and extent are to be verified against documented procedures where applicable. Such safety systems include but are not limited to:
- (i) Bunkering ESD system is to be tested, without fuel in the piping, to verify that ESD system operation will result in a closure of the isolation valves and a shutdown of machinery associated with bunkering operations. All ESD activations and outputs are to be tested including fuel storage tank overfill protection, bunkering isolation valve closure and automatic shutdown of machinery associated with bunkering operations.
 - (ii) Fuel-processing equipment shutdown and closure of isolation valves resulting from:
 - loss of the valve-actuating medium;
 - loss of ventilation in fuel piping double wall /ventilated duct; or
 - loss of pressure of inert gas in pressurised double-walled pipe arrangement.
 - (iii) Fuel processing equipment shutdown and closure of isolation valves as a result of deviation in the fuel supply to the engine-room from the normal operating conditions (temperature and pressure).
 - (iv) Fuel installation shutdown as a result of gas detection.
 - (v) Safety interlocks on fuel-processing equipment are to be examined and tested as necessary to confirm satisfactory condition.
- (b) A General Examination within the areas deemed as hazardous, such as bunker stations, vent mast area, tank connection space and spaces adjacent to vent arrangements from the tank connection space (if applicable), to verify the electrical arrangements have been maintained satisfactorily for operation in a hazardous environment.
- (c) Verification that piping and independent fuel storage tanks are electrically bonded to the hull.

23.7.2 Consideration will be given to simulated testing, provided that it is considered representative. Comprehensive maintenance records, including details of tests carried out in accordance with the fuel plant and instrumentation maintenance manuals may be presented for review. Acceptance of either simulated testing or maintenance records including reports of testing as described above is subject to the satisfaction of the attending Surveyor.

23.8 Complete Surveys – General requirements

23.8.1 The requirements of *Pt 1, Ch 3, 23.1 General* to *Pt 1, Ch 3, 23.7 Intermediate Surveys* are to be complied with.

23.8.2 The items covered by *Pt 1, Ch 3, 23.8 Complete Surveys – General requirements 23.8.3* to *Pt 1, Ch 3, 23.9 Complete Surveys – Natural gas fuelled consumers and other equipment 23.9.5* may, at the request of the Owner, be examined on a Continuous Survey basis provided that the interval between examinations of each item does not exceed five years. Exceptions may be made to this requirement if Condition Based Maintenance arrangements have been agreed and maintained satisfactorily (see *Pt 1, Ch 3, 23.1 General 23.1.9*).

23.8.3 Except where alternative provisions are given in *Pt 1, Ch 3, 23.8 Complete Surveys – General requirements 23.8.6* and *Pt 1, Ch 3, 23.8 Complete Surveys – General requirements 23.8.7* below, all fuel storage tanks are to be examined externally and internally, particular attention being paid to the plating in way of supports of securing arrangements for independent tanks, pipe connections, also to sealing arrangements in way of the deck penetrations. Insulation is to be removed as required.

23.8.4 Provided that the structural examination is satisfactory, that the gas detection systems have been found to be in satisfactory condition, routine on board checks and maintenance records are satisfactory and that the voyage records have not

shown any abnormal operation, fuel storage tanks will not require hydrostatic testing (except as required by *Pt 1, Ch 3, 23.8 Complete Surveys – General requirements 23.8.6*).

23.8.5 The non-destructive testing (NDT) of independent fuel storage tanks is to supplement visual inspection with particular attention to be given to the integrity of the main structural members, tank shell and highly-stressed parts, including welded connections as deemed necessary by the Surveyor. The following items are considered as highly-stressed parts:

- structure in way of tank supports and anti-rolling/anti-pitching devices,
- web frames or stiffening rings,
- swash bulkhead boundaries,
- dome and sump connections to tank shell,
- foundations for pumps, towers, ladders, etc.
- pipe connections.

23.8.6 The NDT testing requirements for different types of independent fuel storage tanks are detailed below; where radiographic or ultrasonic testing is required, at least 10 per cent of the length of the applicable welded connections is to be tested. This testing is to be carried out internally and externally as applicable. Insulation is to be removed as necessary for the required non-destructive testing:

- (a) For independent fuel storage tanks of Type B, the extent of non-destructive testing is to be given in the test schedule specially prepared for the tank design. The Owner is to submit proposals for the extent of non-destructive testing of the fuel storage tanks in advance of the survey.
- (b) For vacuum-insulated independent fuel storage tanks of Type C vacuum monitoring is accepted as a demonstration of the internal integrity of the tank. This is subject to verification that the monitoring equipment is being maintained, operated and calibrated in a satisfactory condition. There is no further requirement for internal examination and testing of these tanks. The tank support arrangements are to be visually examined; non-destructive testing may be required if the condition raises doubt as to the structural integrity.
- (c) For non-vacuum insulated independent fuel storage tanks of Type C non-destructive testing is required on the plating in way of supports and also over selected lengths of welds. Where such testing raises doubt as to the structural integrity, further testing is to be carried out in accordance with the requirements of the manufacturer's test and inspection instructions for hydraulic testing (normally at 1,25 times the approved maximum vapour pressure). Alternatively, consideration will be given to pneumatic testing under special circumstances, provided full details are submitted for approval.
- (d) At each alternate Complete Survey (i.e. at 10 year intervals); non-vacuum insulated independent fuel storage tanks of Type C are to be either:
 - (i) Hydrostatically or hydro-pneumatically tested to not less than 1,25 times MARVS in accordance with the requirements of the manufacturer's test and inspection instructions. The requirements for non-destructive testing in *Pt 1, Ch 3, 23.8 Complete Surveys – General requirements 23.8.5* are to be carried out following this test as required by the Surveyor; or
 - (ii) Subject to a thorough, planned, non-destructive testing. This testing is to be carried out in accordance with a test schedule specially prepared for the tank design. If a special programme does not exist, the following should be tested:
 - structure in way of tank supports and anti-rolling/anti-pitching devices;
 - stiffening rings;
 - Y-connections between tank shell and a longitudinal bulkhead of bi-lobe tanks;
 - swash bulkhead boundaries if applicable;
 - dome and sump connections to the tank shell if applicable;
 - pipe connections.

23.8.7 Membrane fuel storage tank surveys are to be carried out in accordance with approved testing procedures provided by the containment designers.

23.8.8 Fuel storage tank pipe connections and fittings are to be examined, and all valves and cocks in direct communication with the interiors of the tanks are to be opened out for inspection and the connection pipes are to be examined internally, so far as practicable. Special attention is to be paid to the fuel storage tank master isolation valve(s); the valve seat is to be visually examined and the valve tested at the maximum working pressure of the fuel storage tank prior to re-commissioning the fuel system.

23.8.9 Relief valves are to be surveyed as follows:

- (a) The pressure relief valves for the fuel storage tanks are to be opened for examination, adjusted to the correct operating pressure as indicated in *Pt 1, Ch 3, 23.8 Complete Surveys – General requirements 23.8.9*, function-tested, and sealed. If

the tanks are equipped with relief valves with non-metallic membranes in the main or pilot valves, such non-metallic membranes are to be replaced. Valves may be removed from the tank for the purpose of making this adjustment under pressure of air or other suitable gas. If valves are removed, the tank and fuel piping downstream of the tank isolation valves are to be gas-freed and inerted.

- (b) Valves are to lift at a pressure not more than the percentage given below, above the maximum vapour pressure for which the tanks have been approved:
- For 0 to 1,5 bar, 10 per cent.
 - For 1,5 to 3,0 bar, 6 per cent.
 - For pressures exceeding 3,0 bar, 3 per cent.
- (c) Where a detailed record of continuous overhaul and retesting of individually-identifiable relief valves is maintained, consideration will be given to acceptance on the basis of opening, internal examination, and testing of a representative sampling of valves, including each size and type of relief valve in use, provided there is logbook evidence that the remaining valves have been overhauled and tested since the previous Complete Survey.
- (d) Relief valves on fuel piping are to have their pressure settings checked. The valves may be removed from the piping for this purpose. At the Surveyor's discretion a sample of each size and type of valve may be opened for examination and testing.

23.8.10 All fuel pumps, booster pumps and vapour pumps are to be opened out for examination. Where applicable, pumping systems for inter-barrier spaces are to be checked and verified to be in satisfactory condition.

23.8.11 Piping for the fuel processing system including valves, actuators and compensators is to be opened for examination. Insulation may need to be removed, as deemed necessary, to ascertain the condition of the piping. If any doubt exists regarding the integrity of the piping based upon visual examination then, where deemed necessary by the Surveyor, a pressure test at 1,25 times MARVS of the piping is to be carried out. The complete piping systems are to be tested for leaks after re-assembly.

23.8.12 Equipment for the production of inert gas is to be examined and shown to be in satisfactory condition, operating within the gas specification limits. Piping, valves, etc. for the distribution of the inert gas are to be generally examined. Pressure vessels for the storage of inert gas are to be examined internally and externally and the securing arrangements are to be specially examined. Pressure relief valves are to be demonstrated to be in satisfactory condition. Liquid nitrogen storage vessels are to be examined, so far as practicable, and all control equipment, alarms and safety devices are to be verified as operational.

23.8.13 Gastight bulkhead shaft seals are to be opened out so that the sealing arrangements may be checked.

23.8.14 Any sea connections associated with the fuel handling equipment are to be opened out when the ship is in dry dock.

23.8.15 Where an approved condition-monitoring system or condition-based maintenance system is in place, the requirements for opening up of equipment may be reduced accordingly where the condition of the equipment can be shown to be within agreed acceptable limits as detailed in *Pt 5, Ch 21 Requirements for Condition Monitoring Systems and Machinery Condition-Based Maintenance Systems*.

23.8.16 Testing of the tank connection space and cofferdam leakage-detection arrangement (temperature sensors and gas detectors) is to be carried out.

23.8.17 An electrical insulation resistance test of the circuits terminating in, or passing through, hazardous areas, is to be carried out. If the ship is not in a gas-free condition, the results of previously recorded test readings may be accepted together with a review of the on-board monitoring of the earth loop impedance of relevant circuits.

23.9 Complete Surveys – Natural gas fuelled consumers and other equipment

23.9.1 Heat exchangers associated with the fuel installation are to be opened out and examined as follows:

- (a) The water end covers of evaporators are to be removed for examination of the tubes, tube plates and covers.
- (b) Heating medium pumps, including standby pump(s) which may be used on other services, are to be opened out for examination.
- (c) Where a pressure vessel is insulated, sufficient insulation is to be removed, especially in way of connections and supports, to enable the vessel's condition to be ascertained.

Note this refers to external insulation, not additional insulation that may be installed in the annular space of a vacuum insulated tank.

- (d) Insulated piping is to have sufficient insulation removed to enable its condition to be ascertained. Vapour seals are to be specially examined for their condition. Vacuum-insulated piping is to be visually examined and records of maintenance and vacuum monitoring are to be reviewed.

- 23.9.2 The steam side of steam heaters is to be hydraulically tested to 1,5 times the design pressure.
- 23.9.3 Fuel pipe ducts or casings are to be generally examined and the exhaust or inerting arrangements are to be verified.
- 23.9.4 All alarms associated with the natural gas burning systems are to be verified; including, but not limited to, main and auxiliary engines, boilers, incinerators and gas combustion units.
- 23.9.5 The satisfactory condition of all pressure relief valves and/or safety discs throughout the installation is to be verified.

		CLASSIFICATION
PART	1	REGULATIONS
PART	2	RULES FOR THE MANUFACTURE, TESTING AND CERTIFICATION OF MATERIALS
		CHAPTER 1 MATERIALS
PART	3	SHIP STRUCTURES (GENERAL)
PART	4	SHIP STRUCTURES (SHIP TYPES)
PART	5	MAIN AND AUXILIARY MACHINERY
PART	6	CONTROL, ELECTRICAL, REFRIGERATION AND FIRE
PART	7	OTHER SHIP TYPES AND SYSTEMS
PART	8	RULES FOR ICE AND COLD OPERATIONS

Section

1 Rules for the Manufacture Testing and Certification of Materials

■ *Section 1*

Rules for the Manufacture Testing and Certification of Materials

1.1 Reference

Please see *Rules for the Manufacture, Testing and Certification of Materials, July 2015*

		CLASSIFICATION
PART	1	REGULATIONS
PART	2	RULES FOR THE MANUFACTURE, TESTING AND CERTIFICATION OF MATERIALS
PART	3	SHIP STRUCTURES (GENERAL)
		CHAPTER 1 GENERAL
		CHAPTER 2 MATERIALS
		CHAPTER 3 STRUCTURAL DESIGN
		CHAPTER 4 LONGITUDINAL STRENGTH
		CHAPTER 5 FORE END STRUCTURE
		CHAPTER 6 AFT END STRUCTURE
		CHAPTER 7 MACHINERY SPACES
		CHAPTER 8 SUPERSTRUCTURES, DECKHOUSES AND BULWARKS
		CHAPTER 9 SPECIAL FEATURES
		CHAPTER 10 WELDING AND STRUCTURAL DETAILS
		CHAPTER 11 CLOSING ARRANGEMENTS FOR SHELL, DECK AND BULKHEADS
		CHAPTER 12 VENTILATORS, AIR PIPES AND DISCHARGES
		CHAPTER 13 SHIP CONTROL SYSTEMS
		CHAPTER 14 CARGO SECURING ARRANGEMENTS
		CHAPTER 15 QUALITY ASSURANCE SCHEME FOR THE HULL CONSTRUCTION OF SHIPS
		CHAPTER 16 SHIPRIGHT PROCEDURES FOR THE DESIGN, CONSTRUCTION AND LIFETIME CARE OF SHIPS
PART	4	SHIP STRUCTURES (SHIP TYPES)
PART	5	MAIN AND AUXILIARY MACHINERY
PART	6	CONTROL, ELECTRICAL, REFRIGERATION AND FIRE
PART	7	OTHER SHIP TYPES AND SYSTEMS
PART	8	RULES FOR ICE AND COLD OPERATIONS

Section

- 1 **Rule application**
- 2 **Direct calculations**
- 3 **Equivalents**
- 4 **National and International Regulations**
- 5 **Information required**
- 6 **Definitions**
- 7 **Equipment Number**
- 8 **Inspection and workmanship**
- 9 **Procedures for testing tanks and tight boundaries**

■ *Section 1* **Rule application**

1.1 General

1.1.1 The Rules apply in general to single hull ships of normal form, proportions and speed. Relevant parameters to define what is regarded as normal are given by limitations specified at the beginning of individual ship type Chapters. Although the Rules are, in general, for steel ships of all welded construction, other materials for use in hull construction will be considered.

1.2 Exceptions

1.2.1 Ships of unusual form, proportions or speed, intended for the carriage of special cargoes, or for special or restricted service, not covered by *Pt 3 Ship Structures (General)* and *Pt 4 Ship Structures (Ship Types)*, will receive individual consideration based on the general standards of the Rules.

1.2.2 The requirements of *Pt 3, Ch 1, 7.1 Calculation of Equipment Number* are not applicable to Double Hull Oil Tankers or Bulk Carriers with a **CSR** notation (see *Pt 1, Ch 2, 2.3 Class notations (hull)*).

1.3 Loading

1.3.1 The Rules are framed on the understanding that ships will be properly loaded and handled; they do not, unless it is stated or implied in the class notation, provide for special distributions or concentrations of loading other than those included in the approved Loading Manual. The Committee may require additional strengthening to be fitted in any ship which, in their opinion, would otherwise be subjected to severe stresses due to particular features of the design, or where it is desired to make provision for exceptional load or ballast conditions.

1.4 Advisory services

1.4.1 The Rules do not cover certain technical characteristics, such as stability, trim, vibration, docking arrangements, etc. The Committee cannot assume responsibility for these matters but is willing to advise upon them on request.

1.5 Intact stability

1.5.1 New ships to which the Load Lines Conventions are applicable will be assigned Class only after it has been demonstrated that the level of intact stability is adequate, see *Pt 1, Ch 2, 1.1 General 1.1.9*.

■ *Section 2***Direct calculations****2.1 General**

2.1.1 Direct calculations may be specifically required by the Rules or may be required for ships having novel design features, as defined in *Pt 3, Ch 1, 1.2 Exceptions* or may be submitted in support of alternative arrangements and scantlings. Lloyd's Register (hereinafter referred to as 'LR') may, when requested, undertake calculations on behalf of designers and make recommendations in regard to suitability of any required model tests.

2.1.2 Where model testing is undertaken to complement direct calculations the following details would normally be required to be submitted:

- Schedule of tests;
- details of test equipment;
- input data;
- analysis; and
- calibration procedure together with tabulated and plotted output.

2.2 Submission of direct calculations

2.2.1 LR's direct calculation procedures and facilities are summarised in the document entitled *ShipRight Procedures Overview*.

2.2.2 In cases where direct calculations have been carried out using ShipRight procedures, the following supporting information should be submitted as applicable:

- (a) Reference to the ShipRight direct calculation procedure and technical program used.
- (b) A description of the structural modelling.
- (c) A summary of analysis parameters including properties and boundary conditions.
- (d) Details of the loading conditions and the means of applying loads.
- (e) A comprehensive summary of calculation results. Sample calculations should be submitted where appropriate.

2.2.3 In general, submission of large volumes of input and output data associated with such programs as finite element analysis will not be necessary.

2.2.4 The responsibility for error free specification and input of program data and the subsequent correct transposal of output rests with the Builder.

■ *Section 3***Equivalents****3.1 Alternative arrangements and scantlings**

3.1.1 In addition to cases where direct calculations are specifically required by the Rules, LR will consider alternative arrangements and scantlings which have been derived by direct calculations in lieu of specific Rule requirements. All direct calculations are to be submitted for examination.

3.1.2 Where calculation procedures other than those available within ShipRight are employed, supporting documentation is to be submitted for appraisal and this is to include details of the following:

- calculation methods, assumptions and references;
- loading;
- structural modelling;
- direct criteria and their derivation, e.g. permissible stresses, factors of safety against plate panel instability, etc.

3.1.3 LR will be ready to consider use of Builders' programs for direct calculations in the following cases:

- (a) Where it can be established that the program has previously been satisfactorily used to perform a direct calculation similar to that now submitted.
- (b) Where sufficient information and evidence of satisfactory performance is submitted to substantiate the validity of the computation performed by the program.
-

■ *Section 4* **National and International Regulations**

4.1 International Conventions

4.1.1 The Committee, when authorised, will act on behalf of Governments and, if requested, LR will certify compliance in respect of National and International statutory safety and other requirements for passenger and cargo ships.

4.1.2 In satisfying the Load Line Conventions, the general structural strength of the ship is required to be sufficient for the draught corresponding to the freeboards to be assigned. Ships built and maintained in accordance with LR's Rules and Regulations possess adequate strength to satisfy the Load Line Conventions. However, some National Authorities may, in addition, require to be supplied with calculations of bending moments and shear forces for certain conditions of loading.

4.2 International Association of Classification Societies (IACS)

4.2.1 Where applicable, the Rules take into account unified requirements and interpretations established by IACS.

4.3 International Maritime Organization (IMO)

4.3.1 Attention is drawn to the fact that Codes of Practice issued by IMO contain requirements which are outside classification as defined in these Rules and Regulations.

■ *Section 5* **Information required**

5.1 General

5.1.1 The categories and lists of information required are given in *Pt 3, Ch 1, 5.2 Plans and supporting calculations*.

5.1.2 Plans are generally to be submitted in triplicate, but one copy only is necessary for supporting documents and calculations.

5.1.3 Plans are to contain all necessary information to fully define the structure, including construction details, equipment and systems as appropriate.

5.1.4 Additional requirements for individual ship types are given in subsequent Chapters.

5.2 Plans and supporting calculations

5.2.1 Plans covering the following items are to be submitted:

- Midship sections showing longitudinal and transverse material.
 - Profile and decks.
 - Shell expansion.
 - Oiltight and watertight bulkheads.
 - Propeller brackets.
 - Double bottom construction.
 - Pillars and girders.
 - Aft end construction.
 - Engine room construction.
-

- Engine and thrust seatings.
- Fore end construction.
- Hatch coamings.
- Hatch cover construction.
- Deckhouses and superstructures.
- Sternframe.
- Rudder, stock and tiller.
- Equipment.
- Loading Manuals, preliminary and final.
- Ice strengthening.
- Welding.
- Hull penetration plans.
- Support structure for masts, derrick posts or cranes.
- Bilge keels showing material grades, welded connections and detail design.
- Supporting structure of deck fittings used for towing and mooring.

5.2.2 The following supporting documents are to be submitted:

- General arrangement.
- Capacity plan.
- Lines plan or equivalent.
- Dry-docking plan.
- Freeboard plan or equivalent showing freeboards and items relative to the conditions of assignment.
- Towing and mooring arrangements plan as defined in *Pt 3, Ch 1, 5.3 Plans to be supplied to the ship 5.3.10*.
- When the ship is required to comply with statutory damage stability criteria: Watertight Integrity plan or equivalent showing watertight boundaries and associated design head necessary to satisfy damage stability criteria.

5.2.3 The following supporting calculations are to be submitted:

- Calculation of Equipment Number.
- Calculation of hull girder still water bending moment and shear force as applicable.
- Calculation of midship section modulus.
- Calculations for structural items in the aft end, midship and fore end regions of the ship.
- Preliminary freeboard calculation.

5.2.4 Where an ***IWS** (In-water Survey) notation is to be assigned (*see Pt 1, Ch 2, 2.3 Class notations (hull) 2.3.11*), plans and information covering the following items are to be submitted:

- Details showing how rudder pintle and bush clearances are to be measured and how the security of the pintles in their sockets is to be verified with the vessel afloat.
- Details showing how stern bush clearances are to be measured with the vessel afloat.
- Details of high resistance paint, for information only.

5.2.5 Where it is intended to exchange ballast water at sea resulting in the partial filling of the ballast spaces, the scantlings and structural arrangements of the tank boundaries are to be capable of withstanding the loads imposed by the movement of the ballast water in those spaces. The magnitude of the predicated loadings, together with the scantling calculations, may require to be submitted.

5.2.6 Ships that are required to comply with SOLAS Regulation 3-6 in chapter II-1 for 'Access to and within spaces in the cargo area of oil tankers and bulk carriers' are to supply information showing attachment of the access arrangements to the ship structure. This is to include necessary strength calculations, local detail and any reinforcements.

5.2.7 Ships that are required to comply with the *Performance Standards for Protective Coatings* of SOLAS Regulation 3-2 - *Protective coatings of dedicated seawater ballast tanks in all types of ships and double-side skin spaces of bulk carriers* are to submit information on the coating specification agreed by the shipyard, the ship owner and the manufacturer, including the coating system selection, surface preparation and coating application and inspection procedure. Corrosion prevention arrangements and coating system specifications are to comply with *Ch 15 Corrosion Prevention* of the Rules for Materials.

5.3 Plans to be supplied to the ship

5.3.1 To facilitate the ordering of materials for repairs, plans are to be carried in the ship indicating the disposition and grades (other than Grade A) of hull structural steel, the extent and location of higher tensile steel together with details of specification and mechanical properties, and any recommendations for welding, working and treatment of these steels.

5.3.2 Similar information is to be provided when aluminium alloy or other materials are used in the hull construction.

5.3.3 A copy of the final Loading Manual, when approved, and details of the loadings applicable to approved decks, hatch covers and inner bottom are to be placed on board the ship.

5.3.4 Details of any corrosion prevention systems applied or fitted, are to be placed onboard the ship.

5.3.5 For ships that are required to comply with IMO *Performance Standard for Protective Coatings*, a copy of the Coating Technical File (CTF) is to be kept on board the vessel, see *Ch 15 Corrosion Prevention* of the Rules for Materials.

5.3.6 Details of any corrosion control system fitted are to be placed on board the ship.

5.3.7 Copies of main scantling plans are to be placed on board.

5.3.8 Where an ***IWS** (In-water Survey) notation is to be assigned, approved plans and information covering the items detailed in *Pt 3, Ch 1, 5.2 Plans and supporting calculations 5.2.4* are to be placed on board.

5.3.9 Where a ShipRight **CM** (Construction Monitoring) notation or descriptive note is to be assigned, the approved Construction Monitoring Plan (CMP), as detailed in the *ShipRight Construction Monitoring Procedures*, is to be maintained on board the ship.

5.3.10 The towing and mooring arrangements plan is to be provided on board for the guidance of the Master. The information provided on the plan is to include the following in respect of each shipboard fitting:

- Location on the ship.
- Fitting type.
- Safe working load (SWL).
- Purpose of fitting (mooring/harbour towing/escort towing).
- Manner of applying towing or mooring line load, including limiting fleet angles.
- Strength of each mooring line.
- The number of mooring lines supplied on board the ship.

This information is to be incorporated into the pilot card in order to provide the pilot with the necessary information on harbour/escorting operations.

5.4 Fire protection, detection and extinction

5.4.1 For information and plans required, see *Pt 6, Ch 4 Fire Protection, Detection and Extinction Requirements*.

■ Section 6 Definitions

6.1 Principal particulars

6.1.1 Rule length, L , is the distance, in metres, on the waterline at draught T , from the forward side of the stem to the after side of the rudder post or to the centre of the rudder stock if there is no rudder post. L is to be not less than 96 per cent, and need not be greater than 97 per cent, of the extreme length on the waterline. For ships without rudders, the Rule length is to be taken as 97 per cent of the extreme length on the waterline. In ships with unusual stem or stern arrangements the Rule length, L , will be specially considered.

6.1.2 Amidships is to be taken as the middle of the Rule length, L , measuring from the forward side of the stem.

6.1.3 Breadth, B , is the greatest moulded breadth, in metres.

6.1.4 Depth, D , is measured, in metres, at the middle of the length, L , from top of keel to top of the deck beam at side on the uppermost continuous deck, or as defined in appropriate Chapters. When a rounded gunwale is arranged, the depth D is to be measured to the continuation of the moulded deck line.

6.1.5 Draught, T , is the summer draught, in metres, measured from top of keel, or a greater value if such a value has been specified as 'scantling draught'. Both of the draughts are to be indicated on the midship plan, irrespective of whether or not they are of the same value.

6.1.6 The block coefficient, C_b , is the moulded block coefficient at draught, T , based on Rule length, L , and moulded breadth, B , as follows:

$$C_b = \frac{\text{moulded displacement (m}^3\text{) at draught } T}{LBT}$$

6.1.7 Length between perpendiculars, L_{pp} , is the distance, in metres, on the waterline at draught T , from the fore side of the stem to the after side of the rudder post, or to the centre of the rudder stock if there is no rudder post. In ships with unusual stern arrangements the length, L_{pp} , will be specially considered. The forward perpendicular, F.P., is the perpendicular at the intersection of the waterline with the fore side of the stem. The after perpendicular, A.P., is the perpendicular at the intersection of the waterline with the after side of the rudder post. For ships without a rudder post, the A.P. is the perpendicular at the intersection of the waterline with the centreline of the rudder stock.

6.1.8 Load line length, L_L , is to be taken as 96 per cent of the total length on a waterline at 85 per cent of the least moulded depth measured from the top of the keel, or as the length from the fore side of the stem to the axis of the rudder stock on that waterline, if that is greater. In ships designed with a rake of keel, the waterline on which this length is measured is to be parallel to the designed waterline. The length L_L is to be measured in metres.

6.1.9 Load line block coefficient, C_{bL} , is defined as:

$$C_{bL} = \frac{\nabla}{L_L B T_L}$$

where

∇ = volume of the moulded displacement, in m^3 , excluding appendages, taken at draught T_L

T_L = moulded draught, in metres, measured to the waterline at 85 per cent of the least moulded depth.

6.1.10 Maximum service speed, V , means the maximum ahead service speed, in knots, which the ship is designed to maintain, at the summer load waterline at maximum propeller RPM and corresponding MCR.

6.1.11 Bow reference height, H_b , is defined as:

For ships less than 250 m in length:

$$H_b = 0,056L_L \left(1 - \frac{L_L}{500}\right) \left(\frac{1,36}{C_{bL} + 0,68}\right) \text{m}$$

For ships 250 m or greater in length:

$$H_b = 7 \left(\frac{1,36}{C_{bL} + 0,68}\right) \text{m}$$

where

L_L = is defined in Pt 3, Ch 1, 6.1 Principal particulars 6.1.8

C_{bL} = is defined in Pt 3, Ch 1, 6.1 Principal particulars 6.1.9.

6.2 Freeboard deck

6.2.1 The freeboard deck is normally the uppermost complete deck exposed to weather and sea, which has permanent means of closing all openings in the weather part, and below which all openings in the sides of the ship are fitted with permanent means of watertight closing.

6.2.2 For the purposes of the Load Lines Conventions, as applicable, where the assigned summer freeboard is increased such that the resulting draught is not more than that corresponding to a minimum summer freeboard for the same ship, but with

an assumed freeboard deck located a distance below the actual freeboard deck at least equal to the standard superstructure height, the related items for the conditions of assignment to the actual freeboard deck may be as required for a superstructure deck.

6.3 Weathertight

6.3.1 A closing appliance is considered weathertight if it is designed to prevent the passage of water into the ship in any sea conditions.

6.3.2 Generally, all openings in the freeboard deck and in enclosed superstructures are to be provided with weathertight closing appliances.

6.4 Watertight

6.4.1 A closing appliance is considered watertight if it is designed to prevent the passage of water in either direction under a head of water for which the surrounding structure is designed.

6.4.2 Generally, all openings below the freeboard deck in the outer shell/envelope (and in main bulkheads) are to be fitted with permanent means of watertight closing.

6.5 Position 1 and Position 2

6.5.1 For the purpose of Load Line conditions of assignment, there are two basic positions of hatchways, doorways and ventilators defined as follows:

- | | | |
|------------|---|--|
| Position 1 | - | Upon exposed freeboard and raised quarterdecks, and exposed superstructure decks within the forward 0,25 of the load line length. |
| Position 2 | - | Upon exposed superstructure decks abaft the forward 0,25 of the load line length and located at least one standard height of superstructure above the freeboard deck. Upon exposed superstructure decks situated within the forward 0,25 of the Load Line length and located at least two standard heights of superstructure above the freeboard deck. |

6.6 Passenger ship

6.6.1 A passenger ship is a ship which carries more than 12 passengers.

6.7 Reference system

6.7.1 For hull reference purposes, the ship is divided into 21 equally spaced stations where Station 0 is the after perpendicular, Station 20 is the forward perpendicular, and Station 10 is mid- L_{pp} .

6.8 Co-ordinate system

6.8.1 Unless otherwise stated, the co-ordinate system is as shown in *Figure 1.6.1 Co-ordinate system*, that is, a right-hand co-ordinate system with the X axis positive forward, the Y axis positive to port and the Z axis positive upwards. Angular motions are considered positive in a clockwise direction about the X, Y or Z axes.

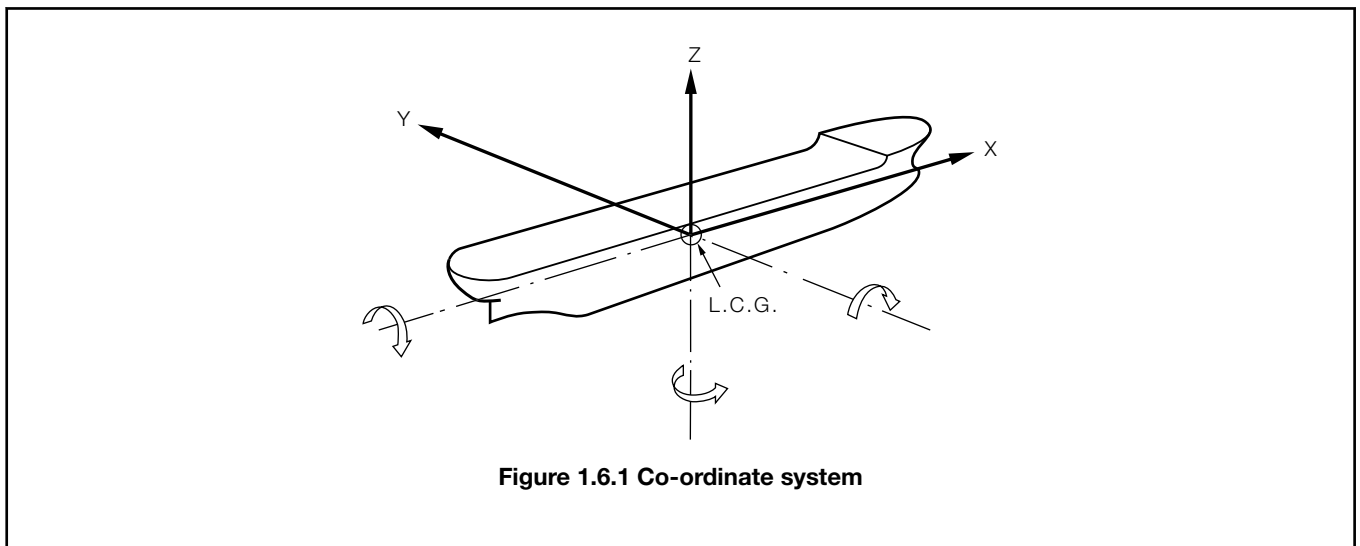

Figure 1.6.1 Co-ordinate system

■ **Section 7**
Equipment Number

7.1 Calculation of Equipment Number

7.1.1 The equipment of anchors and chain cables specified in *Pt 3, Ch 13, 7 Equipment* is based on an 'Equipment Number' which is to be calculated as follows:

$$\text{Equipment Number} = \Delta^{\frac{2}{3}} + 2BH + \frac{A}{10}$$

where

A = area, in m², in profile view of the hull, within the Rule length of the vessel, and of superstructures and houses above the summer load waterline, which are within the Rule length of the vessel, and also having a breadth greater than $\frac{B}{4}$

= See also *Pt 3, Ch 1, 7.1 Calculation of Equipment Number 7.1.3* and *Pt 3, Ch 1, 7.1 Calculation of Equipment Number 7.1.4*

B = greatest moulded breadth, in metres

H = freeboard amidships, in metres, from the summer load waterline to the upper deck, plus the sum of the heights at the centreline, in metres, of each tier of houses having a breadth greater than $\frac{B}{4}$

= See also *Pt 3, Ch 1, 7.1 Calculation of Equipment Number 7.1.2*, *Pt 3, Ch 1, 7.1 Calculation of Equipment Number 7.1.3* and *Pt 3, Ch 1, 7.1 Calculation of Equipment Number 7.1.4*

Δ = moulded displacement, in tonnes, to the summer load waterline.

7.1.2 In the calculation of *H* and *A*, sheer and trim are to be ignored. Where there is a local discontinuity in the upper deck, *H* is to be measured from a notional deckline.

7.1.3 If a house having a breadth greater than $\frac{B}{4}$ is above a house with a breadth of $\frac{B}{4}$ or less, then the wide house is to be included, but the narrow house ignored.

7.1.4 Screens and bulwarks more than 1,5 m in height are to be regarded as parts of houses when determining *H* and *A*. Where a screen or bulwark is of varying height, the portion to be included is to be that length the height of which exceeds 1,5 m.

7.1.5 The Equipment Number for tugs is to be calculated as follows:

$$EquipmentNumber = \Delta^{\frac{2}{3}} + 2(Bf + \Sigma bh) + \frac{A}{10}$$

where

Δ, B and A = are defined in Pt 3, Ch 1, 7.1 Calculation of Equipment Number 7.1.1

b = breadth, in metres, of the widest superstructure or deckhouse on each tier.

f = freeboard amidships, in metres, from the summer load waterline

h = the height, in metres, of each tier of superstructure or deckhouse at side having a breadth of $\frac{B}{4}$ or greater. In the calculation of h , sheer and trim are to be ignored.

■ **Section 8**
Inspection and workmanship

8.1 Inspection

8.1.1 Adequate facilities are to be provided to enable the Surveyor to carry out a satisfactory inspection of all components during each stage of prefabrication and construction.

8.2 Workmanship

8.2.1 All workmanship is to be of good quality and in accordance with good shipbuilding practice. Any defect is to be rectified to the satisfaction of the Surveyor before the material is covered with paint, cement or other composition. The materials and welding are to be in accordance with the requirements of the *Rules for the Manufacture, Testing and Certification of Materials, July 2015*. The assembly sequence and welding sequence are to be agreed prior to construction and are to be to the satisfaction of the Surveyor. Plates which have been subjected to excessive heating while being worked are to be satisfactorily heat treated before being erected in the hull.

8.2.2 **Wood sheathing on decks.** Where plated decks are sheathed with wood, the sheathing is to be efficiently attached to the deck, caulked and sealed, to the satisfaction of the Surveyor.

8.2.3 **Rudder and sternframe.** The final boring out of the propeller boss and sternframe skeg or solepiece, and the fit-up and alignment of the rudder, pintles and axles, are to be carried out after completing the major part of the welding of the after part of the ship. The contacts between the conical surfaces of pintles, rudder stocks and rudder axles are to be checked before the final mounting.

8.3 Trial trip and operational tests

8.3.1 The items listed in *Table 1.8.1 Trial trip and operational tests* are to be tested on completion of the installation or at sea trials.

Table 1.8.1 Trial trip and operational tests

Item	Requirement
Sliding watertight doors	To be operated under working conditions
Windlass	An anchoring test is to be carried out in the presence of the Surveyor. The test should demonstrate that the windlass with brakes, etc. functions satisfactorily, and that the power to raise anchor can be developed and satisfies the Rule requirements. For Rule requirements, see Pt 3, Ch 13, 7 Equipment.

Steering gear, main and auxiliary	To be tested under working conditions, to the satisfaction of the Surveyors, to demonstrate that the Rule requirements are met For Rule requirements, see Pt 5, Ch 19 Steering Arrangements.
Bilge suction in holds, and hand pumps in peak spaces	To be tested under working conditions to the satisfaction of the Surveyors.

■ **Section 9**
Procedures for testing tanks and tight boundaries

9.1 General

9.1.1 The test procedures detailed in this Section are to be used to confirm the watertightness of tanks and watertight boundaries, the structural adequacy of tanks and weathertightness of structures.

9.2 Application

9.2.1 The testing requirements for gravity tanks, defined as tanks subject to a vapour pressure not greater than 70 kN/m², and other boundaries required to be watertight or weathertight, are to be tested in accordance with this Section. Tests are to be carried out in the presence of a Surveyor at a stage sufficiently close to completion such that the strength and tightness are not subsequently impaired and prior to any sealing and cement work being applied over joints see also Pt 3, Ch 1, 9.7 Application of coating.

9.2.2 Attention is drawn to SOLAS Regulation 11 - Initial testing of watertight bulkheads, etc.. Exemptions of structural tests detailed in SOLAS Regulation 11 - Initial testing of watertight bulkheads, etc. are to be agreed with the relevant Flag Administration.

9.2.3 The testing of cargo containment systems of liquefied gas carriers are to be in accordance with the requirements of Ch 4 of the Rules and Regulations for the Classification of Ships for the Carriage of Liquefied Gases in Bulk.

9.2.4 The testing of structures not listed in this Section are to be specially considered.

Table 1.9.1 Testing requirements

Item to be tested	Testing procedure	Testing requirement
Double bottom tanks, see Note 1	Leak and structural	The greater of: <ul style="list-style-type: none"> • head of water up to the top of the overflow • head of water 2,4 m above top of tank, see Note 2 • head of water up to bulkhead deck
Combined double bottom and hopper side tanks	Leak and structural	The greater of: <ul style="list-style-type: none"> • head of water up to the top of the overflow • head of water representing the maximum pressure experienced in service
Double bottom voids, see Note 3	Leak	
Double side tanks	Leak and structural	The greater of: <ul style="list-style-type: none"> • head of water up to the top of the overflow • head of water 2,4 m above top of tank, see Note 2 • head of water up to bulkhead deck
Combined double bottom, lower hopper and topside tanks	Leak and structural	
Topside tanks	Leak and structural	

Double side voids	Leak	
Deep tanks (other than those listed elsewhere)	Leak and structural	The greater of: <ul style="list-style-type: none"> • head of water up to the top of the overflow • head of water 2,4 m above top of tank, see Note 2
Cargo oil tanks, and fuel oil bunkers	Leak and structural	The greater of: <ul style="list-style-type: none"> • head of water up to the top of the overflow • head of water 2,4 m above top of tank, see Note 2 • head of water up to top of tank, see Note 2, plus setting of fitted pressure-relief valve
Scupper and discharge pipes in way of tanks	Leak and structural	
Ballast hold of bulk carriers	Leak and structural	<ul style="list-style-type: none"> • Head of water up to the top of cargo hatch coaming, see Note 10
Holds used for in-port ballasting	Leak and structural	A head of water representing the maximum loading that will occur in-port as indicated in the Loading Manual.
Peak tanks, see Note 4	Leak and structural	The greater of: <ul style="list-style-type: none"> • head of water up to the top of the overflow • head of water 2,4 m above top of tank, see Note 2
Fore peak spaces with equipment	Leak	
Fore peak voids	Leak and structural	Head of water up to the bulkhead deck, see Note 8
Aft peak spaces with equipment	Leak	
Aft peak voids, see Note 4	Leak	
Cofferdams	Leak	
Watertight bulkheads	Leak	See Note 5
Superstructure end bulkhead	Leak	
Watertight doors below freeboard or bulkhead deck	Leak	See Notes 5 and 6
Double plate rudder blades	Leak	
Shaft tunnel clear of deep tanks	Leak	See Note 5
Shell doors when fitted in place	Leak	See Notes 5 and 7
Weather-tight hatch covers and closing appliances	Leak	See Note 5
Steel hatch covers fitted to the cargo oil tanks and cargo holds of ships used for the alternate carriage of oil cargo and dry bulk cargo	Leak	See Note 5
Chain locker	Leak and structural	Head of water up to top of chain pipe
Independent edible liquid tanks	Leak and structural	The greater of: <ul style="list-style-type: none"> • head of water up to the top of the overflow • head of water 0,9 m above top of tank, see Note 2
L.O. Sump tanks and other similar tanks/spaces under main engines	Leak	See Note 5

Ballast ducts	Leak and structural	The greater of: <ul style="list-style-type: none"> • ballast pump maximum pressure • setting of pressure-relief valve
Chemical tanker cargo tanks	Leak and structural	The greater of: <ul style="list-style-type: none"> • head of water 2,4 m above top of tank, see Notes 2 and 9 • head of water up to top of tank, see Notes 2 and 9, plus setting of fitted pressure-relief valve
<p>Note 1. Including tanks arranged in accordance with the provisions of SOLAS <i>Regulation 9 - Double bottoms in passenger ships and cargo ships other than tankers.</i></p> <p>Note 2. Top of tank is the deck forming the top of the tank, excluding any hatchways. In holds for liquid cargo or ballast with large hatch openings, the top of tank is to be taken to the top of the hatch.</p> <p>Note 3. Including dry compartments and duct keels arranged in accordance with the provisions of SOLAS <i>Regulation 9 - Double bottoms in passenger ships and cargo ships other than tankers</i> and <i>Regulation 11 - Initial testing of watertight bulkheads, etc. .2</i>, as well as voids used for the protection of fuel oil tanks and pump rooms arranged in accordance with the provisions of MARPOL Annex 1, <i>Regulation 12A – Oil fuel tank protection</i> and <i>Regulation 22 - Pump-room bottom protection</i> .</p> <p>Note 4. Testing of the aft peak is to be carried out after the sterntube has been fitted.</p> <p>Note 5. A hose test will be considered, see <i>Pt 3, Ch 1, 9.5 Leak test procedures 9.5.2</i> and <i>Pt 3, Ch 1, 9.6 Definitions and details of tests 9.6.3.</i></p> <p>Note 6. Watertight doors not confirmed watertight by a prototype test are to be subject to a hydrostatic test, see SOLAS <i>Regulation 16 - Construction and initial tests of watertight doors, sidescuttles, etc..</i></p> <p>Note 7. For shell doors providing watertight closure, watertightness is to be demonstrated through prototype testing before installation. The testing procedure is to be agreed with LR prior to testing.</p> <p>Note 8. Where demonstrated to be impracticable, the structural testing of fore peak void spaces may be exempted subject to the agreement of the attending Surveyor.</p> <p>Note 9. Where a cargo tank is designed for the carriage of cargoes with a specific gravity greater than 1,0, an appropriate additional head is to be considered.</p> <p>Note 10. Where air vents are fitted below the top of the coaming, adequate blanking off of these vents may be required prior to the commencement of the test.</p> <p>Note 11. Other testing methods listed in <i>Pt 3, Ch 1, 9.6 Definitions and details of tests 9.6.7</i> and <i>Pt 3, Ch 1, 9.6 Definitions and details of tests 9.6.8</i> may be considered, subject to adequacy of such testing methods being verified, see SOLAS <i>Regulation 11 - Initial testing of watertight bulkheads, etc..</i></p>		

9.3 Test types

9.3.1 The types of test specified in this Section are:

- (a) **Structural test:** which is to be conducted to verify the tightness and structural adequacy of the construction of tanks. This may be a hydrostatic test or, where the situation warrants, a hydropneumatic test.
- (b) **Leak test:** which is to be used to verify the tightness of a boundary. Unless a specific test is indicated, this may be a hydrostatic, hydropneumatic test, air or other medium test.

9.4 Structural test procedures

9.4.1 Where a structural test is specified in *Table 1.9.1 Testing requirements*, unless specified otherwise, a hydrostatic test is to be carried out in accordance with *Pt 3, Ch 1, 9.6 Definitions and details of tests 9.6.1*. Where practical limitations prevent a hydrostatic test being carried out, a hydropneumatic test in accordance with *Pt 3, Ch 1, 9.6 Definitions and details of tests 9.6.2* is to be conducted. All external boundaries of the tested space are to be examined for structural distortion, bulging, buckling, or other related damage and/or leaks.

9.4.2 A hydrostatic test or hydropneumatic test may be carried out afloat to confirm the structural adequacy of tanks, provided that a leak test is carried out and the results are confirmed as satisfactory before the vessel is afloat.

9.4.3 For tanks of the same structural design, configuration and the same general workmanship, as determined by the attending Surveyor, a structural test may be carried out on only one tank, provided all subsequent tanks are tested for leaks by an air test. The relaxation to accept leak testing using an air test instead of a structural test does not apply to cargo space boundaries adjacent to other compartments in tankers and combination carriers or to the boundaries of tanks for segregated cargoes or pollutants.

9.4.4 Where the structural adequacy of a tank has been verified by structural testing on a previous vessel in a series, tanks of structural similarity on subsequent vessels within that series (which are built at the same shipyard) may be exempt from such testing, provided that the watertightness of all exempt tanks is verified by leak tests and thorough inspection. However, structural testing is to be carried out for at least one tank of each type of tank on every vessel in the series. The relaxation to accept leak testing and thorough inspections instead of a structural test on subsequent vessels in a series does not apply to cargo space boundaries adjacent to other compartments in tankers and combination carriers or to the boundaries of tanks for segregated cargoes or pollutants.

9.4.5 For sister ships built two or more years after the delivery of the last ship of the series, the relaxation provided for in *Pt 3, Ch 1, 9.4 Structural test procedures 9.4.4* may be accepted provided that the general practices, equipment and workmanship of the shipyard have been maintained continuously, and an enhanced NDT programme is implemented for the tanks not subject to structural tests.

9.4.6 Tanks exempted from structural testing in *Pt 3, Ch 1, 9.4 Structural test procedures 9.4.3* and *Pt 3, Ch 1, 9.4 Structural test procedures 9.4.4* may require structural testing if found necessary after the structural testing of the first tank.

9.4.7 Consideration is to be given to the selection of tanks to be structurally tested. Selected tanks are to be chosen so that all representative structural members are tested for the expected tension and compression.

9.4.8 For watertight boundaries of spaces other than tanks, excluding ballast holds, chain lockers and cargo holds which are intended to be used for in-port ballasting, structural testing may be exempted completely, provided that the watertightness in all boundaries of exempted spaces are verified by leak tests and thorough inspection. The testing of ballast holds, chain lockers and cargo holds which are intended to be used for in-port ballasting, are to comply with the requirements of *Pt 3, Ch 1, 9.4 Structural test procedures 9.4.1* to *Pt 3, Ch 1, 9.4 Structural test procedures 9.4.7*.

9.5 Leak test procedures

9.5.1 Where a leak test is specified in *Table 1.9.1 Testing requirements*, unless specified otherwise, a tank air test, compressed air fillet weld test, or vacuum box test is to be carried out in accordance with the applicable requirements of *Pt 3, Ch 1, 9.6 Definitions and details of tests 9.6.4* to *Pt 3, Ch 1, 9.6 Definitions and details of tests 9.6.6*. A hydrostatic or hydropneumatic test conducted in accordance with the applicable requirements of *Pt 3, Ch 1, 9.6 Definitions and details of tests 9.6.1* and *Pt 3, Ch 1, 9.6 Definitions and details of tests 9.6.2* will be accepted as a leak test on the condition that safe access to all joints being examined is provided, see *Pt 3, Ch 1, 9.8 Safe access to joints 9.8.1*. Where a hydrostatic or hydropneumatic test is applied as a leak test, the external boundaries are to be free of any liquid residue prior to the commencement of the test.

9.5.2 A hose test will be accepted as means of verifying the tightness of joints only in specific locations, identified in *Table 1.9.1 Testing requirements*.

9.5.3 Air tests of joints may be conducted at any stage during construction provided that all work that might affect the tightness of the joint is completed before the test is carried out.

9.5.4 Where acceptable to the attending Surveyor, provided that careful visual inspections show a continuous uniform weld profile shape, free from repairs, and the results of selected NDE testing show no significant defects, the leak testing of automatic butt welds and semi-automatic (flux core arc welding) butt welds may be omitted.

9.6 Definitions and details of tests

9.6.1 **Hydrostatic test** is a test conducted by filling a space with a liquid to a specified head. Unless another liquid is approved, the hydrostatic test is to consist of filling a space with either fresh or sea-water, whichever is appropriate for the space being tested, to the level specified in *Table 1.9.1 Testing requirements*. For tanks intended to carry cargoes of a higher density than the test liquid, the head of the liquid is to be specially considered.

9.6.2 **Hydropneumatic test** is a combination of a hydrostatic test and a tank air test, consisting of partially filling a tank with water and conducting a tank air test on the unfilled portion of the tank. A hydropneumatic test, where approved, is to be such that the test condition in conjunction with the approved liquid level and air pressure will simulate the actual loading as far as practicable. The requirements for tank air testing shown in *Pt 3, Ch 1, 9.6 Definitions and details of tests 9.6.4* are to be adhered to.

9.6.3 **Hose test** is a test used to verify the tightness of joints with a jet of water. The jet of water is to be directed perpendicular to the joint. It is to be carried out with the pressure in the hose nozzle maintained at not less than 2,0 bar during the test. The hose nozzle is to have a minimum inside diameter of 12 mm and is to be situated no further than 1,5 m from the joint. Where a hose test is not practical because of possible damage to machinery, electrical equipment insulation or outfitting items, it may be replaced by a careful visual examination of welded connections, supported by an ultrasonic or penetration leak test, or an equivalent, see SOLAS Regulation 11 - Initial testing of watertight bulkheads, etc..

9.6.4 **Tank air test** is to be used to verify the tightness of a compartment by means of an air pressure differential and leak indicator solution. An efficient indicating solution (e.g. soapy water) is to be applied to the weld or penetration being tested and is to be examined whilst an air pressure differential of not less than 0,15 bar is applied by pumping air into the compartment. Arrangements are to be made to ensure that any increase in air pressure does not exceed 0,30 bar. A U-tube with a height sufficient to hold a head of water corresponding to the required test pressure is to be used for verification and to avoid overpressure. The cross-sectional area of the U-tube is not to be less than that of the pipe supplying air to the tank. Alternatively two calibrated pressure gauges may be considered acceptable. All boundary welds, including pipe connections in the compartment are to be examined twice. The first is to be examined immediately upon applying the leak indication solution; the second approximately five minutes afterwards.

9.6.5 **Compressed air fillet weld test.** This test consists of compressed air being injected into one end of a fillet welded joint and the pressure verified at the other end of the joint by a pressure gauge. Pressure gauges are to be arranged so that an air pressure of at least 0,15 bar above atmospheric pressure can be verified at each end of all passages within the portion being tested. A leak indicator solution is to be applied and the weld line examined for leaks. A compressed air test may be carried out for partial penetration welds where the root face is greater than 6 mm.

9.6.6 **Vacuum box test** is a test used to verify the tightness of joints by means of a localised air pressure differential and leak indicator solution. The test is to be conducted with the use of a box with air connections, gauges and an inspection window that is to be placed over the joint being tested with a leak indicator solution applied. The air within the box is to be removed by an ejector to create a vacuum i.e. a pressure differential of 0,20 to 0,26 bar inside the box.

9.6.7 **Ultrasonic test** may be used where a hose test is not practical to verify the tightness of a boundary, see Pt 3, Ch 1, 9.6 Definitions and details of tests 9.6.3. An arrangement of ultrasonic echo transmitters is to be placed inside a compartment and a receiver outside. The receiver is to be used to detect any leaks in the compartment.

9.6.8 **Penetration test** may be used where a hose test is not practical to assess butt welds, see Pt 3, Ch 1, 9.6 Definitions and details of tests 9.6.3, by applying a low surface tension liquid to one side of a compartment boundary. When no liquid is detected on the opposite side of the boundary after expiration of a defined period of time, the verification of tightness of the compartment's boundary may be assumed. A developer solution may be applied on the other side of the weld to aid leak detection.

9.6.9 Other methods of testing may be considered and are to be agreed by LR prior to commencement of testing.

9.7 Application of coating

9.7.1 A final coating may be applied over automatic butt welds before the completion of a leak test, provided that careful visual inspections show continuous uniform weld profile shape, free from repairs, and the results of selected NDE testing show no significant defects. For all other joints, the final coating is to be applied after the completion of a leak test. The Surveyor reserves the right to require a leak test prior to the application of the final coating over automatic erection butt welds.

9.7.2 Any temporary coating which may conceal defects or leaks is to be applied at a time as specified for the final coating, see Pt 3, Ch 1, 9.7 Application of coating 9.7.1. This requirement does not apply to shop primer.

9.8 Safe access to joints

9.8.1 For leak tests, safe access to all joints under examination is to be provided.

Section

- 1 **Materials of construction**
- 2 **Fracture control**
- 3 **Corrosion protection**
- 4 **Deck covering**

■ *Section 1*
Materials of construction

1.1 General

1.1.1 The Rules relate in general to the construction of steel ships, although consideration will be given to the use of other materials.

1.1.2 The materials used in the construction of the ship are to be manufactured and tested in accordance with the requirements of the *Rules for the Manufacture, Testing and Certification of Materials, July 2015* (hereinafter referred to as Rules for Materials). Materials for which provision is not made therein may be accepted, provided that they comply with an approved specification and such tests as may be considered necessary.

1.1.3 The requirements in this Chapter are not applicable to Double Hull Oil Tankers or Bulk Carriers with a **CSR** notation (see *Pt 1, Ch 2, 2.3 Class notations (hull)*) with the exception of *Pt 3, Ch 2, 1.2 Steel 1.2.6* and *Pt 3, Ch 2, 3.2 Prefabrication primers* which are to be complied with.

1.2 Steel

1.2.1 Steel having a specified minimum yield stress of 235 N/mm² (24 kgf/mm²) is regarded as mild steel. Steel having a higher specified minimum yield stress is regarded as higher tensile steel.

1.2.2 For the determination of the hull girder section modulus, where higher tensile steel is used, a higher tensile steel factor, k_L , is given in *Table 2.1.1 Values of k_L* .

Table 2.1.1 Values of k_L

Specified minimum yield stress in N/mm ² (kgf/mm ²)	k_L
235 (24)	1,0
265 (27)	0,92
315 (32)	0,78
355 (36)	0,72
390 (40)	0,68 (0,66 see Note 3)
460 (47) see Note 3	0,62 see Note 3

Note 1. Intermediate values by linear interpolation.

Note 2. For the purpose of calculating hull moment of inertia as specified in *Pt 3, Ch 4, 5.8 Hull moment of inertia 5.8.1*, $k_L = 1,0$.

Note 3. Grade only applies to thickness above 50 mm for upper deck, hatch coamings, shear strake, uppermost strake of longitudinal bulkhead and other longitudinal strength members in way of the above structures of container ships. The requirements specified in *Ch 3, 3 Higher strength steels for ship and other structural applications* of the Rules for Materials apply, see *Pt 3, Ch 2, 1.2 Steel 1.2.4* and *Pt 3, Ch 2, 1.2 Steel 1.2.5*.

1.2.3 The local scantling requirements of higher tensile steel plating, longitudinals, stiffeners and girders may be based on a k factor determined as follows:

$$k = \frac{235}{\sigma_o} \left(k = \frac{24}{\sigma_o} \right)$$

or 0,66, whichever is the greater,

where

σ_o = specific minimum yield stress in N/mm² (kgf/mm²)

1.2.4 For the application of the requirements of *Pt 3, Ch 2, 1.2 Steel 1.2.2* and *Pt 3, Ch 2, 1.2 Steel 1.2.3*, special consideration will be given to steel where $\sigma_o > 355$ N/mm² (36 kgf/mm²). Where such steel grades are used in areas which are subject to fatigue loading, the structural details are to be verified using fatigue design assessment methods.

1.2.5 For container ships only, a k_L factor of 0,66 may be applied to steel with a specified minimum yield stress of 390 N/mm² (40 kgf/mm²), or a k_L factor of 0,62 may be applied to steel with a specified minimum yield stress of 460 N/mm² (47 kgf/mm²) for structural members that contribute to the ship's longitudinal strength, provided that:

- (a) the member's plate or web thickness is greater than 50 mm;
- (b) the requirements of *Pt 3, Ch 2, 1.2 Steel 1.2.4* are satisfied; and
- (c) a spectral fatigue assessment is carried out in accordance with *ShipRight Fatigue Design Assessment* (FDA level 3) procedure, to demonstrate that key structural details sensitive to the hull girder loads have satisfactory fatigue performance. The assessment should normally include the following:
 - Hatch corners in way of cross-deck strips;
 - Hatch corners at the forward region;
 - Hatch corners forward and aft of the engine room and the accommodation blocks;
 - Connection of hatch coaming to supporting structure; and
 - Other critical locations subject to dynamic hull girder bending and torsional effects.

In addition, the ShipRight Construction Monitoring (CM) procedure is to be applied to the fatigue critical locations described above.

1.2.6 Where steel castings or forgings are used for sternframes, rudder frames, rudder stocks, propeller shaft brackets and other major structural items, they are to comply with *Ch 4 Steel Castings* or *Ch 5 Steel Forgings* of the Rules for Materials, as appropriate.

1.3 Aluminium

1.3.1 The use of aluminium alloy is permitted for superstructures, deckhouses, hatch covers, helicopter platforms, or other local components on board ships.

1.3.2 Aluminium is not to be used for the crowns or casings of Category A machinery spaces, see *Pt 5, Ch 1, 4.8 Category A machinery spaces 4.8.1*.

1.3.3 Except where otherwise stated, equivalent scantlings are to be derived as follows:

- (a) Plating thickness;

$$t_a = t_s \sqrt{k_a c}$$

- (b) Section modulus of stiffeners;

$$Z_a = Z_s k_a c$$

where

c = 0,95 for high corrosion resistant alloy

= 1,00 for other alloys

$$k_a = \frac{245}{\sigma_a}$$

t_a = thickness of aluminium plating

t_s = thickness of mild steel plating

Z_a = section modulus of aluminium stiffener

where

Z_s = section modulus of mild steel stiffener

σ_a = 0,2 per cent proof stress or 70 per cent of the ultimate strength of the material, whichever is the lesser.

1.3.4 In general, for welded structure, the maximum value of σ_a to be used in the scantlings derivation is that of the aluminium in the welded condition. However, consideration will be given to using unwelded values depending upon the weld line location, other heat affected zones, in relation to the maximum applied stress on the member (e.g. extruded sections).

1.3.5 A comparison of the mechanical properties for selected welded and unwelded alloys is given in *Ch 13, 8.3 Fabrication and welding 8.3.2* of the Rules for Materials.

1.3.6 Where strain hardened grades (designated Hxxx) are used, adequate protection by coating is to be provided to avoid the risk of stress corrosion cracking.

■ Section 2 Fracture control

2.1 Grades of steel

2.1.1 The resistance to fracture is controlled, in part, by the notch toughness of the steel used in the structure. Steels with different levels of notch toughness are specified in the *Rules for the Manufacture, Testing and Certification of Materials, July 2015*. The grade of steel to be used is, in general, related to the thickness of the material and the stress pattern associated with its location.

2.1.2 In order to distinguish between the material grade requirements for different hull members at varying locations along the ship, material classes are assigned as shown in *Table 2.2.1 Material classes and grades*. For each class, depending on thickness, the material grade requirements are not to be lower than those given in *Table 2.2.2 Steel grades*.

2.1.3 Where tee or cruciform connections employ full penetration welds, and the plate material is subject to significant strains in a direction perpendicular to the rolled surfaces, it is recommended that consideration be given to the use of special plate material with specified through thickness properties, as detailed in *Ch 3, 8 Plates with specified through thickness properties* of the Rules for Materials.

2.1.4 Design for normal worldwide service assumes the navigation to areas of minus 10°C, where the design air temperature is to be taken as the lowest mean daily average air temperature in the area of operation:

where

Mean = statistical mean over a minimum of 20 years

Average = average during one day and one night

Lowest = lowest during the year

MDHT = Mean Daily High Temperature

MDAT = Mean Daily Average Temperature

MDLT = Mean Daily Low Temperature

Figure 2.2.1 Design air temperature shows the definition graphically.

The material grade of exposed structure of ships intended to operate in external air temperatures below minus 10°C will be specially considered, see also *Provisional Rules for the Winterisation of Ships, July 2015*.

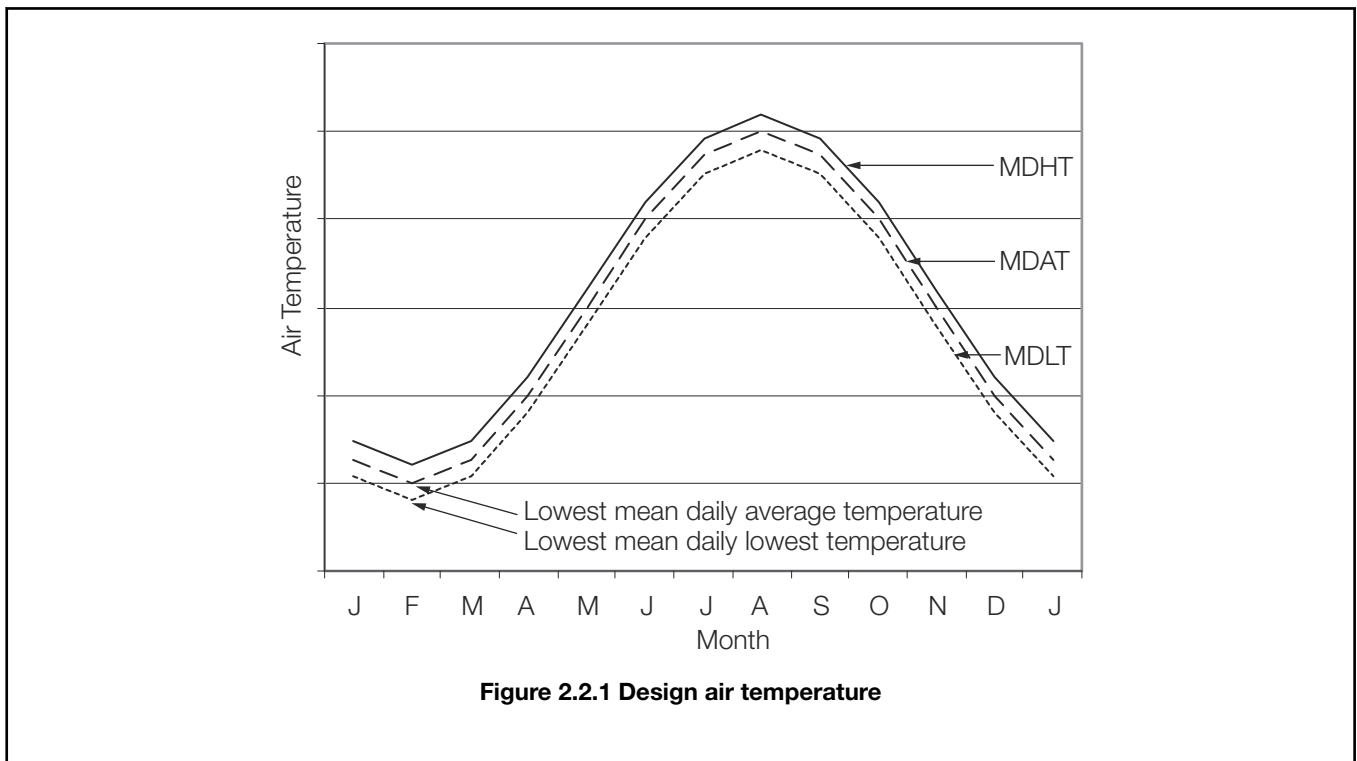

2.2 Refrigerated spaces

2.2.1 Where the minimum design temperature of the steel falls below 0°C in refrigerated spaces, in addition to the requirements of Pt 3, Ch 2, 2.1 Grades of steel 2.1.2, the grade of steel for the following items is to comply, in general, with the requirements of Table 2.2.3 Grades of steel for refrigerated spaces with a minimum design temperatures below 0°C:

- Deck plating.
- Webs of deck girders.
- Longitudinal bulkhead strakes attached to deck.
- Shelf plates and their face bars supporting hatch covers.

2.2.2 Unless a temperature gradient calculation is carried out to assess the design temperature in the items defined in Pt 3, Ch 2, 2.2 Refrigerated spaces 2.2.1, the temperature to which the steel deck may be subjected is to be assessed as shown in Table 2.2.4 Assessment of deck temperature.

Table 2.2.1 Material classes and grades

Structural member category		Material class/Minimum grade
SECONDARY		
A1.	Longitudinal bulkhead strakes, other than belonging to the Primary category	Class I within 0,4L amidships Grade A/AH outside 0,4L amidships
A2.	Deck plating exposed to weather, other than that belonging to the Primary or Special category	
A3.	Side plating	
PRIMARY		
B1.	Bottom plating, including keel plate	
B2.	Strength deck plating, excluding that belonging to the Special category	

B3.	Continuous longitudinal plating of strength members above strength deck, excluding hatch coamings	Class II within 0,4L amidships
B4.	Uppermost strake in longitudinal bulkhead	Grade A/AH outside 0,4L amidships
B5.	Vertical strake (hatch side girder) and uppermost sloped strake in top wing tank	
SPECIAL		
C1.	Sheerstrake (or rounded gunwale) and stringer plate at strength deck, see Note 1	Class III within 0,4L amidships
C2.	Deck strake at longitudinal bulkhead excluding deck plating in way of inner skin bulkhead of double hull ships, see Note 1	Class II outside 0,4L amidships Class I outside 0,6L amidships
C3.	Strength deck plating at outboard corners of cargo hatch openings (and plating intersections of the longitudinal underdeck girders and the cross-deck strips) in container carriers and other ships with similar hatch opening configurations	Class III within 0,4L amidships Class II outside 0,4L amidships Class I outside 0,6L amidships Minimum Class III within cargo region
C4.	Strength deck plating at corners of cargo hatch openings in bulk carriers (see Pt 3, Ch 2, 1.1 General 1.1.3), ore carriers, combination carriers and other ships with similar hatch opening configurations	Class III within 0,6L amidships
C5.	Trunk deck and inner deck plating at corners of openings for liquid and gas domes in membrane type liquefied gas carriers	Class II within rest of cargo region
C6.	Bilge strake in ships with double bottom over the full breadth and length less than 150 m	Class II within 0,6L amidships Class I outside 0,6L amidships
C7.	Bilge strake in other ships , see Note 1	Class III within 0,4L amidships Class II outside 0,4L amidships Class I outside 0,6L amidships
C8.	Longitudinal hatch coamings of length greater than 0,15L including coaming top plate and flange	Class III within 0,4L amidships Class II outside 0,4L amidships
C9.	End brackets and deck house transition of longitudinal cargo hatch coamings	Class I outside 0,6L amidships Not to be less than Grade D/DH
ADDITIONAL REQUIREMENTS FOR SINGLE STRENGTH DECK SHIPS OF LENGTH GREATER THAN 150 m.		
D1.	Longitudinal plating of strength deck where contributing to the longitudinal strength	Grade B/AH within 0,4L amidships
D2.	Continuous longitudinal plating of strength members above strength deck	
D3.	Continuous longitudinal trunk deck plating of membrane type liquefied gas carriers	Class II within 0,4L amidships
D4.	Single side strakes for ships without inner continuous longitudinal bulkhead(s) between bottom and strength deck	Grade B/AH within cargo region
ADDITIONAL REQUIREMENTS FOR SHIPS OF LENGTH GREATER THAN 250 m.		

E1.	Sheerstrake (or rounded gunwale) and stringer plate at strength deck, see Note 2	Grade E/EH within 0,4L amidships
E2.	Bilge strake, see Note 2	Grade D/DH within 0,6L amidships
SINGLE SKIN BULK CARRIERS SUBJECTED TO SOLAS REGULATION XII/6.5		
F1.	Lower bracket of ordinary side frame, see Notes 6 and 7	Grade D/DH
F2.	Side shell strakes included totally or partially between the two points located to 0,125l above and below the intersection of side shell and bilge hopper sloping plate or inner bottom plate, see Note 7	Grade D/DH
<p>Note 1. Single strakes required to be of Class III and within 0,4L amidships are to have breadths not less than $800 + 5L$ mm, but need not be greater than 1800 mm, unless limited by the geometry of the ship's design.</p> <p>Note 2. Single strakes required to be of Grade E/EH and within 0,4L amidships are to have breadths not less than $800 + 5L$ mm, but need not be greater than 1800 mm, unless limited by the geometry of the ship's design.</p> <p>Note 3. For strength members not mentioned, Grade A/AH may be generally used.</p> <p>Note 4. Steel grade is to correspond to the as-fitted thickness.</p> <p>Note 5. Plating materials for sternframes supporting the rudder and propeller boss, rudders, rudder horns and shaft brackets are, in general, not to be of lower grades than corresponding to Class II. For rudder and rudder body plates subjected to stress concentrations (e.g. in way of lower support of semi-spade rudders or at upper part of spade rudders) Class III is to be applied.</p> <p>Note 6. The term 'lower bracket' means webs of lower brackets and webs of the lower part of side frames up to the point of 0,125l above the intersection of side shell and bilge hopper sloping plate or inner bottom plate.</p> <p>Note 7. The span of the side frame, <i>l</i>, is defined as the distance between the supporting structures.</p> <p>Note 8. Corner inserts in way of complex openings such as for lifts and side doors which may impinge on the deck plating or stringer plate are to be of Grade D/DH for $t \leq 20$ mm and Grade E/EH for $t > 20$ mm.</p> <p>Note 9. The material class used for reinforcement and the quality of material (i.e. whether mild or higher tensile steel) used for welded attachments, such as waterway bars and bilge keels, is to be similar to that of the hull envelope plating in way. Where attachments are made to rounded gunwale plates, special consideration will be given to the required grade of steel, taking account of the intended structural arrangements and attachment details.</p> <p>Note 10. The material class for deck plating, sheer strake and upper strake of longitudinal bulkhead within 0,4L amidships is also to be applied at structural breaks of the superstructure, irrespective of position.</p> <p>Note 11. Engine seat top plates outside 0,6L amidships may be Grade A/AH. Steel grade requirement for top plates within 0,6L amidships will be specially considered.</p>		

Table 2.2.2 Steel grades

Thickness, <i>t</i> , in mm	Material class					
	I		II		III	
	Mild steel	H.T. steel	Mild steel	H.T. steel	Mild steel	H.T. steel
$t \leq 15$	A	AH	A	AH	A	AH
$15 < t \leq 20$	A	AH	A	AH	B	AH
$20 < t \leq 25$	A	AH	B	AH	D	DH
$25 < t \leq 30$	A	AH	D	DH	D	DH
$30 < t \leq 35$	B	AH	D	DH	E	EH
$35 < t \leq 40$	B	AH	D	DH	E	EH

$t > 40$	D	DH	E	EH	E	EH
Note See Notes under Table 2.2.1 Material classes and grades						

Table 2.2.3 Grades of steel for refrigerated spaces with a minimum design temperatures below 0°C

Minimum design temperature, in °C	Thickness, in mm	Grades of steel
<0 to -10	$t \leq 12,5$	B/AH
	$12,5 < t \leq 25,5$	D/DH
	$t > 25,5$	E/EH
<-10 to -25	$t \leq 12,5$	D/DH
	$t > 12,5$	E/EH
<-25 to -40	$t \leq 12,5$	E/EH
	$t > 12,5$	FH/LT-FH, <i>see also Ch 3, 6 Ferritic steels for low temperature service of the Rules for Materials</i>

Table 2.2.4 Assessment of deck temperature

Arrangement	Deck temperature
(1) Deck not covered with insulation in the refrigerated space	Temperature of the refrigerated space
(2) Deck covered with insulation in the refrigerated space and not insulated on the other side	Temperature of the space on the uninsulated side
(3) Deck covered with insulation on both sides	
(a) Temperature difference not greater than 11°C	Mean of the temperatures of the spaces above and below the deck
(b) Temperature difference greater than 11°C but not greater than 33°C	Mean of the temperatures of the spaces above and below the deck less 3°C
(c) Temperature difference greater than 33°C	Deck temperature will be specially assessed
Note Where one of the internal spaces concerned is not refrigerated, the temperature of the space is to be taken as 5°C.	

■ **Section 3**
Corrosion protection

3.1 General

3.1.1 Where bimetallic connections are made, measures are to be incorporated to mitigate galvanic corrosion.

3.2 Prefabrication primers

3.2.1 Prefabrication primers are to be approved in accordance with *Ch 15 Corrosion Prevention* of the Rules for Materials.

3.2.2 Aluminium coatings intended for oil tankers and chemical tankers used in way of the cargo oil tanks, cargo tank deck areas, pumprooms, cofferdams or any other area where oil vapour may accumulate are to be coated using systems containing less than 10 per cent aluminium by weight in the dry film.

3.3 Internal cathodic protection

3.3.1 The requirements for cathodic protection of internal tanks in *Ch 15 Corrosion Prevention* of the Rules for Materials are to be complied with. When a cathodic protection system is to be fitted in tanks for the carriage of liquid cargo with flash point not exceeding 60°C, a plan showing details of the locations and attachment of anodes is to be submitted. The arrangements will be considered for safety against fire and explosion aspects only. Impressed current cathodic protection systems are not permitted in any tank.

3.3.2 Particular attention is to be given to the locations of anodes in relation to the structural arrangements and openings of the tank.

3.3.3 Anodes are to be of approved design and sufficiently rigid to avoid resonance in the anode support. Steel cores are to be fitted, and these are to be so designed as to retain the anode even when the latter is wasted.

3.3.4 Anodes are to be attached to the structure in such a way that they remain secure both initially and during service. The following methods of attachment would be acceptable:

- (a) Steel core connected to the structure by continuous welding of adequate section.
- (b) Steel core bolted to separate supports, provided that a minimum of two bolts with lock nuts is used at each support. The separate supports are to be connected to the structure by continuous welding of adequate section.
- (c) Approved means of mechanical clamping.

3.3.5 Anodes are to be attached to stiffeners, or may be aligned in way of stiffeners on plane bulkhead plating, but they are not to be attached to the shell. The two ends are not to be attached to separate members which are capable of relative movement.

3.3.6 Where cores or supports are welded to the main structure, they are to be kept clear of the toes of brackets and similar stress raisers. Where they are welded to asymmetrical stiffeners, they are to be connected to the web with the welding kept at least 25 mm away from the edge of the web. In the case of stiffeners or girders with symmetrical face plates, the connection may be made to the web or to the centreline of the face plate but well clear of the free edges. However, it is recommended that anodes are not fitted to face plates of higher tensile steel longitudinals.

3.4 Aluminium and magnesium anodes

3.4.1 Aluminium and aluminium alloy anodes are permitted in tanks used for the carriage of oil, but only at locations where the potential energy does not exceed 275 J (28 kgf m). The weight of the anode is to be taken as the weight at the time of fitting, including any inserts and fitting devices.

3.4.2 The height of the anode is, in general, to be measured from the bottom of the tank to the centre of the anode. Where the anode is located on, or closely above, a horizontal surface (such as a bulkhead girder) not less than 1 m wide, provided with an upstanding flange or face plate projecting not less than 75 mm above the horizontal surface, the height of the anode may be measured above that surface.

3.4.3 Aluminium anodes are not to be located under tank hatches or Butterworth openings unless protected by adjacent structure.

3.4.4 Magnesium or magnesium alloy anodes are permitted only in tanks intended solely for water ballast.

3.5 External hull protection

3.5.1 Suitable protection of the underwater portion of the hull is to be provided.

3.5.2 Where a cathodic protection system is fitted, plans showing the proposed layout of anodes and hull penetrations are to be submitted in accordance with *Ch 15 Corrosion Prevention* of the Rules for Materials.

3.5.3 The arrangement for glands, where cables pass through the shell, are to include a small cofferdam. Cables to anodes are not to be led through tanks intended for the carriage of low flash point oils. Where cables are led through cofferdams or clean ballast tanks of tankers, they are to be enclosed in a substantial steel tube of about 10 mm thickness, see also *Pt 6, Ch 2, 14.10 Requirements for tankers intended for the carriage in bulk of oil cargoes having a flash point not exceeding 60°C (closed-cup test)*.

3.5.4 Where an ***IWS** (In-water Survey) notation is to be assigned, see *Pt 1, Ch 2, 2.3 Class notations (hull) 2.3.11*, protection of the underwater portion of the hull is to be provided by means of a suitable high resistance paint applied in accordance with the manufacturer's requirements. Details of the high resistance paint are to be submitted for information in accordance with *Ch 15 Corrosion Prevention* of the Rules for Materials.

3.6 Application of coatings and alternative means of protection

3.6.1 For ships that are required to comply with IMO Resolution MSC.215(82) - *Performance Standard for Protective Coatings for Dedicated Seawater Ballast Tanks in all Types of Ships and Double-Side Skin Spaces of Bulk Carriers - (Adopted on 8 December 2006)*, all dedicated sea-water ballast tanks of all types of ships and double-side skin spaces of bulk carriers are to comply with all of the requirements of the Resolution, see ShipRight Procedure *Anti-Corrosion Systems Notation* and *Ch 15 Corrosion Prevention* of the Rules for Materials.

3.6.2 For ships that are required to comply with IMO Resolution MSC.288(87) - *Performance Standard for Protective Coatings for Cargo Oil Tanks of Crude Oil Tankers - (Adopted on 14 May 2010)*, all cargo oil tanks are to comply with all of the requirements of the Resolution, see ShipRight Procedure *Anti-Corrosion System Notation* and *Ch 15 Corrosion Prevention* of the Rules for Materials.

3.6.3 For ships that are required to comply with the IMO Resolution MSC.289(87) - *Performance Standard for Alternative Means of Corrosion Protection for Cargo Oil Tanks of Crude Oil Tankers - (Adopted on 14 May 2010)*, by application of corrosion resistant steel, see *Ch 3, 1.3 Corrosion resistant steels for cargo oil tanks of crude oil tankers* of the Rules for Materials, all cargo oil tanks are to comply with all of the requirements of the Resolution, see ShipRight Procedure *Anti-Corrosion System Notation* and *Ch 15 Corrosion Prevention* of the Rules for Materials.

3.6.4 For ships that are required to comply with IMO Resolution MSC.244(83) - *Adoption of Performance Standard for Protective Coatings for Void Spaces on Bulk Carriers and Oil Tankers - (Adopted on 5 October 2007)*, all void spaces are to comply with all of the requirements of the Resolution, see ShipRight Procedure *Anti Corrosion System Notation* and *Ch 15 Corrosion Prevention* of the Rules for Materials.

3.6.5 For ships that are not required to comply with the IMO Resolution MSC.215(82) - *Performance Standard for Protective Coatings for Dedicated Seawater Ballast Tanks in all Types of Ships and Double-Side Skin Spaces of Bulk Carriers - (Adopted on 8 December 2006)*, all sea-water ballast spaces having boundaries formed by the hull envelope are to have an efficient protective coating, epoxy or equivalent, applied in accordance with the manufacturer's recommendations, see ShipRight Procedure *Protective Coatings in Water Ballast Tanks (PCWBT)* and *Ch 15 Corrosion Prevention* of the Rules for Materials.

3.6.6 The following tanks are not considered to be dedicated sea-water ballast tanks and are therefore exempted from the application and requirement of the IMO PSPC:

- (a) ballast tanks identified as 'Spaces included in Net Tonnage' in the 1969 ITC Certificate;
- (b) sea-water ballast tanks in passenger vessels also designated for the carriage of grey water or black water; or
- (c) sea-water ballast tanks in livestock carriers also designated for the carriage of the livestock dung.

Alternative provisions are to be made for the protection of these tanks.

■ Section 4 Deck covering

4.1 General

4.1.1 Where plated decks are sheathed with wood or an approved composition, reductions in plate thickness may be allowed.

4.1.2 The steel deck is to be coated with a suitable material in order to prevent corrosive action, and the sheathing or composition is to be effectively secured to the deck.

4.1.3 Primary deck coverings within accommodation spaces, control stations or service spaces are to be of a type which will not readily ignite or give rise to smoke or toxic or explosive hazards at elevated temperatures in accordance with the requirements of the *International Code for the Application of Fire Test Procedures*.

Section

- 1 **General**
- 2 **Rule structural concepts**
- 3 **Structural idealisation**
- 4 **Bulkhead requirements**
- 5 **Design loading**
- 6 **Minimum bow heights, reserve buoyancy and extent of forecastle**

■ Section 1 General

1.1 Application

1.1.1 This Chapter illustrates the general principles to be adopted in applying the Rule structural requirements given in *Pt 3 Ship Structures (General)* and *Pt 4 Ship Structures (Ship Types)*. In particular, consideration has been given to the layout of the Rules as regards the different regions of the ship, principles for taper of hull scantlings, definition of span point, derivation of section moduli and basic design loading for deck structures. Principles for subdivision are also covered.

1.1.2 Where additional requirements relating to particular ship types apply, these are, in general, dealt with under the relevant ship type Chapter in *Pt 4 Ship Structures (Ship Types)*.

1.1.3 The requirements in this chapter are not applicable to Double Hull Oil Tankers or Bulk Carriers with a **CSR** notation (see *Pt 1, Ch 2, 2.3 Class notations (hull)*) with the exception of *Pt 3, Ch 3, 4.7 Protection of tanks carrying fuel oil, lubricating oil, vegetable or similar oils* which is to be complied with.

■ Section 2 Rule structural concepts

2.1 Definition of requirements

2.1.1 In *Figure 3.2.1 Rule Scantlings - Schematic layout of requirements* the breakdown of the ship into regions is shown. Within each region, the applicable Parts and Chapters of the Rules are indicated.

2.2 Definition of fore end region

2.2.1 The fore end region structure is considered to include structure forward of the midship 0,4L region.

2.3 Definition of aft end region

2.3.1 The aft end region structure is considered to include all structure aft of the midship 0,4L region.

2.4 Symbols

2.4.1 The symbols used in this Section are defined as follows:

F_D, F_B = local scantling reduction factor as defined in *Pt 3, Ch 4, 5.7 Local reduction factors*

k_L, k = higher tensile steel factor, see *Pt 3, Ch 2, 1.2 Steel*

Z_D, Z_B = vertical distance, in metres, from the hull transverse neutral axis to the moulded deck line at side and to the top of keel respectively

Z_{ht} = vertical extent of higher tensile steel.

2.5 Taper requirements for hull envelope

2.5.1 The thickness of the shell envelope and strength deck plating, and the modulus and sectional area of strength deck longitudinals are to taper gradually from the midship region to the fore and aft ends. For the requirements, see *Table 3.2.1 Taper requirements for hull envelope*.

2.5.2 Outside the line of openings where higher tensile steel is used amidships and mild steel at the ends, the equivalent mild steel midship thickness for plating, equivalent mild steel midship deck longitudinal area and equivalent mild steel midship total deck area, for taper purposes are to be determined as follows:

(a) Equivalent mild steel value

$$= \frac{\text{H.T. steel value}}{k_L}$$

(b) If the higher tensile steel plating is based on minimum thickness requirements, then:

Equivalent mild steel midship plating thickness determined from *Pt 4, Ch 1 General Cargo Ships* and *Pt 4, Ch 9 Double Hull Oil Tankers*.

2.5.3 The transition from higher tensile steel to mild steel is to be as shown in *Figure 3.2.2 Transition of steel grades* for the forward region. The transition in the aft region is to be similar to the forward region.

2.5.4 Where the higher tensile steel longitudinals extend beyond the point of transition from higher tensile to mild steel plating, the modulus of the composite section is not to be taken less than the required mild steel value at the deck plate flange, and k times the mild steel value at the higher tensile flange.

2.6 Vertical extent of higher tensile steel

2.6.1 Higher tensile steel may be used for both deck and bottom structures or deck structure only. Where fitted, it is to be used for the whole of the longitudinal continuous material for the following vertical distances:

(a) from the line of deck at side

$$Z_{ht} = \left(1 - \frac{k_L}{F_D}\right) Z_D$$

(b) from the top of keel

$$Z_{ht} = \left(1 - \frac{k_L}{F_B}\right) Z_B$$

In the above formulæ F_D and F_B are to be taken not less than k_L .

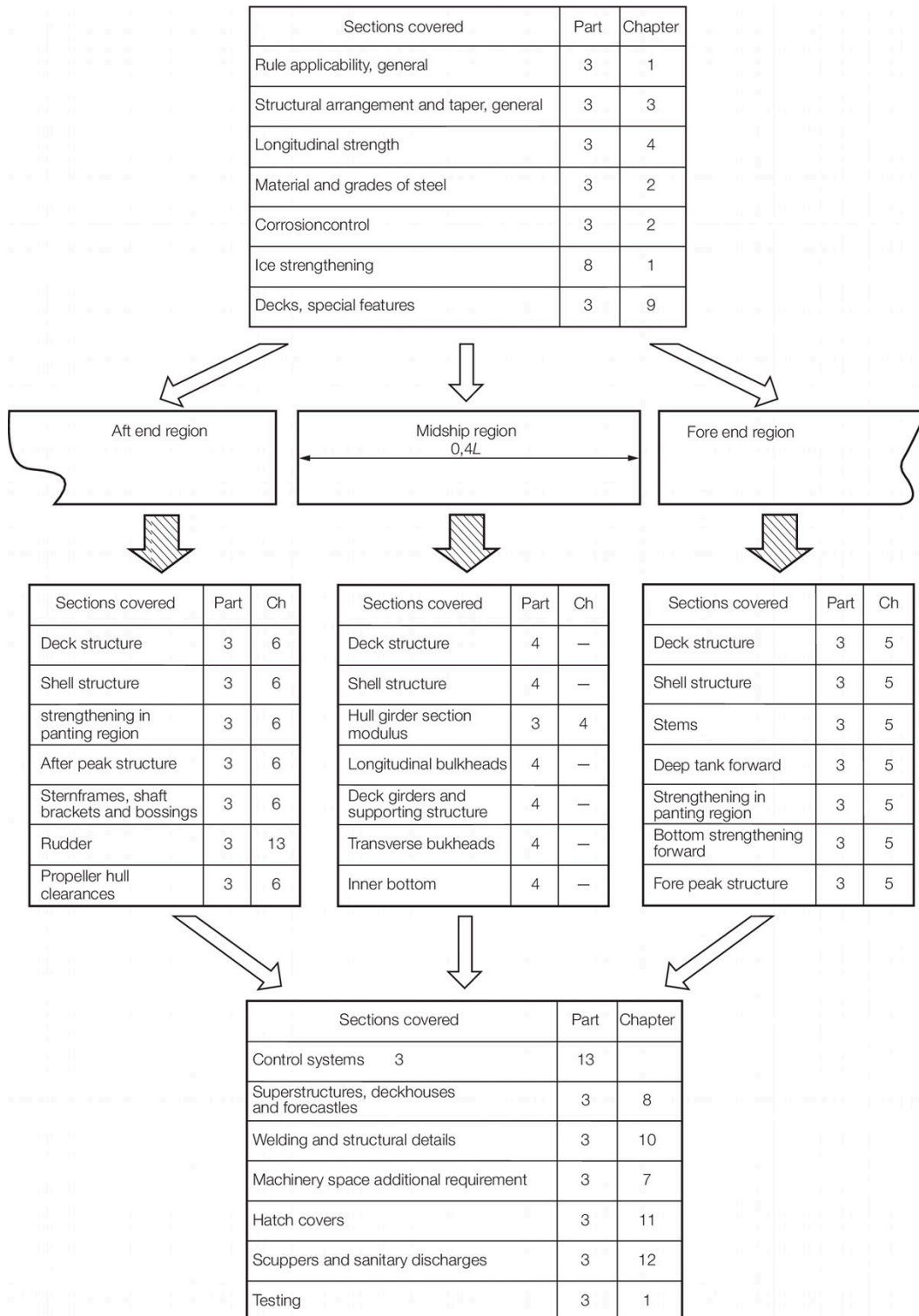

Figure 3.2.1 Rule Scantlings - Schematic layout of requirements

Table 3.2.1 Taper requirements for hull envelope

Item	Location	Requirement
Plating		
(1) Shell envelope plating, see Notes 1 and 2	Fore and aft ends	The thickness, in mm, is to be the greater of the following:(a) $t_t = \left[(t_c - t_{e1}) \left(1 - \frac{d}{0,225L} \right) + t_{e1} \right]$ (see Note 3) (b) $t_t = (6,5 + 0,033L) \sqrt{\frac{ks_1}{s_b}}$
(2) Strength deck plating, see Notes 1 and 2	Fore and aft ends	The thickness, in mm, is to be the greater of the following: (a) $t_t = \left[(t_c - t_{e2}) \left(1 - \frac{d}{0,225L} \right) + t_{e2} \right]$ (see Note 3) (b) $t_t = (5,5 + 0,02L) \sqrt{\frac{ks_1}{s_b}}$
Longitudinals outside 0,4L amidships		
(3) Strength deck, see Notes 1 and 2	Fore and aft ends	<p>MODULUSThe section modulus in association with deck plating, in cm³, is to be the greater of the following: (a) $Z_t = \left[(Z_c - Z_e) \left(1 - \frac{d}{0,225L} \right) + Z_e \right]$ (see Note 3) (b) As determined by <i>Table 5.2.3 Strength/weather deck longitudinals forward</i>, <i>Table 6.2.3 Strength/weather deck longitudinals aft</i>, and <i>Pt 4, Ch 9 Double Hull Oil Tankers</i>, as appropriate</p> <p>SECTIONAL AREA The deck longitudinals may be gradually tapered outside the 0,4L amidships region in association with the deck plating on the basis of area. The sectional area of one longitudinal without plating, in cm², is to be not less than the following: $A_t = \left[(A_c - A_e) \left(1 - \frac{d}{0,225L} \right) + A_e \right]$ (see Note 3)</p>
Strength deck area		
(4) Deck area taper, see Notes 1 and 2	Fore and aft decks	The total area of longitudinals and deck plating outside line of openings at midship region should have a linear taper from 0,2L from midships to 0,075L from F.P. or A.P. such that the area at 0,075L and 0,15L from the F.P. or A.P. is not less than 30 and 50 per cent respectively of the total midships area, see Note 3.
Symbols		
<p><i>L, k, s</i> as defined in <i>Pt 3, Ch 5, 1.4 Symbols and definitions 1.4.1</i></p> <p>d = distance, in m, from 0,2L forward or aft of amidships to the mid-length of the building block, strake, or longitudinal under consideration</p> <p>s_b = standard frame spacing, in mm, as given in <i>Table 5.2.1 Strength/weather deck plating forward (excluding forecastle deck)</i> and <i>Table 5.3.1 Shell plating forward</i> in Chapter 5, and <i>Table 6.2.1 Strength/weather deck plating aft (excluding poop deck)</i> and <i>Table 6.3.1 Shell plating aft</i> in Chapter 6, as appropriate</p> <p>s₁ = <i>s</i>, but is to be taken not less than <i>s_b</i></p>		

t_c = actual thickness of deck or shell plating within the 0,4L midships region

t_{e1} = basic shell end thickness for taper and is $(6,5 + 0,033L) \sqrt{k}$ at 0,075L from the A.P. or F.P.

t_{e2} = basic strength deck end thickness for taper and is $(5,5 + 0,02L) \sqrt{k}$ at 0,075L from the A.P. or F.P.

t_t = taper thickness for strength deck and shell plating

Z_c = section modulus of deck longitudinal in association with deck plating, in cm^3 , within the 0,4L midships region

Z_e = section modulus of deck longitudinal in association with deck plating in cm^3 , at 0,075L from the ends

Z_t = taper section modulus of deck longitudinal in association with deck plating, in cm^3

A_c = cross-sectional area of one longitudinal without attached plating, in cm^2 , within the 0,4L midships region

A_e = cross-sectional area of one longitudinal without attached plating, in cm^2 , at 0,075L from the ends

A_t = taper cross-sectional area of one longitudinal without attached plating, in cm^2

Note 1. For thickness of strength deck and shell plating in way of cargo tanks of double hull oil tankers, single hull oil tankers or ore carriers, see also Pt 4, Ch 9 Double Hull Oil Tankers, Pt 4, Ch 10 Single Hull Oil Tankers, or Pt 4, Ch 11 Ore Carriers as appropriate.

Note 2. The taper requirement does not apply to container ships or open type ships, see Pt 3, Ch 4, 2.3 Open type ships, where the requirements of Pt 4, Ch 8, 3.2 Longitudinal strength are applicable, nor to fast cargo ships where the requirements of Pt 4, Ch 1, 3 Longitudinal strength are applicable. See also Pt 3, Ch 4, 5 Hull bending strength for hull section modulus requirement away from the midship area.

Note 3. The formulae for the taper values are based on the assumption that the quality of steel is the same at amidships and ends. Where higher tensile steel is used in the midship region and mild steel at the ends, the taper values should be calculated for both qualities of steel in way of the transition from higher tensile to mild steel, and applied as determined by Pt 3, Ch 3, 2.5 Taper requirements for hull envelope 2.5.2 and Pt 3, Ch 3, 2.5 Taper requirements for hull envelope 2.5.3.

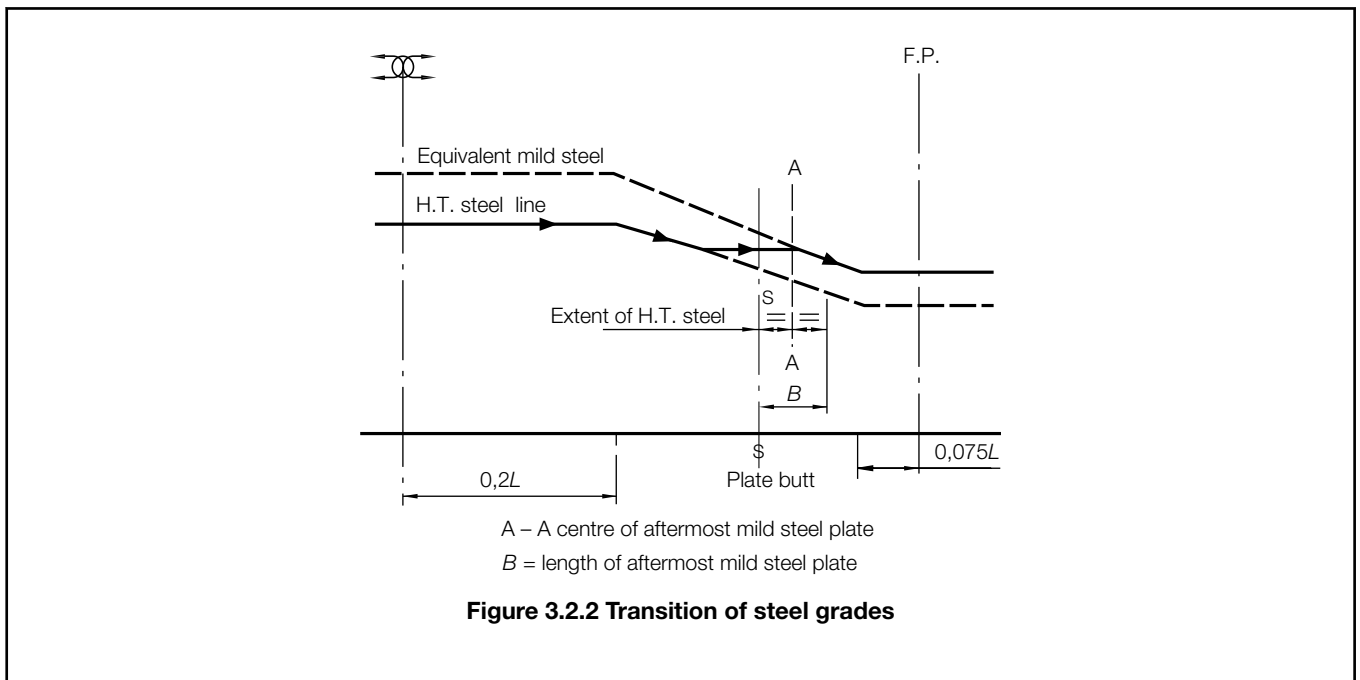

2.7 Grouped stiffeners

2.7.1 Where stiffeners are arranged in groups of the same scantling, the section modulus requirement of each group is to be based on the greater of the following:

- (a) the mean value of the section modulus required for individual stiffeners within the group,
- (b) 90 per cent of the maximum section modulus required for individual stiffeners within the group.

■ **Section 3
Structural idealisation**

3.1 General

3.1.1 For derivation of scantlings of stiffeners, beams, girders, etc. the formulae in the Rules are normally based on elastic or plastic theory using simple beam models supported at one or more points and with varying degrees of fixity at the ends, associated with an appropriate concentrated or distributed load.

3.1.2 Apart from local requirement for web thickness or flange thicknesses, the stiffener, beam or girder strength is defined by a section modulus and moment of inertia requirement.

3.2 Geometric properties of section

3.2.1 The symbols used in this sub-Section are defined as follows:

b = the actual width, in metres, of the load-bearing plating, i.e. one-half of the sum of spacings between parallel adjacent members or equivalent supports

f = $0,3 \left(\frac{1}{b}\right)^{2/3}$, but is not to exceed 1,0. Values of this factor are given in *Table 3.3.1 Load bearing plating factor*

l = the overall length, in metres, of the primary support member, see *Figure 3.3.3 Span points*

t_p = the thickness, in mm, of the attached plating. Where this varies, the mean thickness over the appropriate span is to be used.

Table 3.3.1 Load bearing plating factor

$\frac{l}{b}$	f	$\frac{l}{b}$	f
0,5	0,19	3,5	0,69
1,0	0,30	4,0	0,76
1,5	0,39	4,5	0,82
2,0	0,48	5,0	0,88
2,5	0,55	5,5	0,94
3,0	0,62	6 and above	1,00

Note Intermediate values to be obtained by linear interpolation.

3.2.2 The effective geometric properties of rolled or built sections may be calculated directly from the dimensions of the section and associated effective area of attached plating. Where the web of the section is not normal to the attached plating, and the angle exceeds 20°, the properties of the section are to be determined about an axis parallel to the attached plating.

3.2.3 The geometric properties of rolled or built stiffener sections and of swedges are to be calculated in association with effective area of attached load bearing plating of thickness t_p mm and of width 600 mm or $40t_p$ mm, whichever is the greater. In no case, however, is the width of plating to be taken as greater than either the spacing of the stiffeners or the width of the flat plating between swedges, whichever is appropriate. The thickness, t_p , is the actual thickness of the attached plating. Where this varies, the mean thickness over the appropriate span is to be used.

3.2.4 The effective section modulus of a corrugation over a spacing p is to be calculated from the dimensions and, for symmetrical corrugations, may be taken as:

$$Z = \frac{d_w}{6000} (3bt_p + ct_w) \text{ cm}^3$$

where d_w , b , t_p , c and t_w are measured, in mm, and are as shown in *Figure 3.3.1 Corrugation dimensions*. The value of b is to be taken not greater than:

$$50t_p\sqrt{k} \text{ for welded corrugations}$$

$$60t_p\sqrt{k} \text{ for cold formed corrugations}$$

The value of θ is to be not less than 40°. The moment of inertia is to be calculated from:

$$I = \frac{Z}{10} \left(\frac{d_w}{2} \right) \text{ cm}^4$$

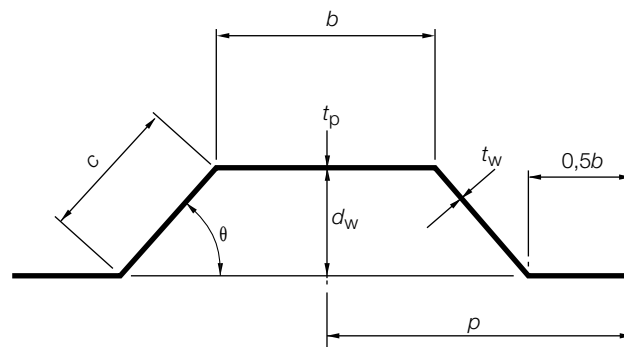

Figure 3.3.1 Corrugation dimensions

3.2.5 The section modulus of a double plate bulkhead over a spacing b may be calculated as:

$$Z = \frac{d_w}{6000} (6fbt_p + d_w t_w) \text{ cm}^3$$

where d_w , b , t_p and t_w are measured, in mm, and are as shown in Figure 3.3.2 Double plate bulkhead dimensions .

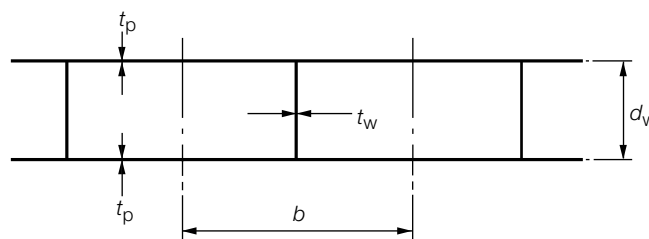

Figure 3.3.2 Double plate bulkhead dimensions

3.2.6 The effective section modulus of a built section may be taken as:

$$Z = \frac{ad_w}{10} + \frac{t_w d_w^2}{6000} \left(1 + \frac{200(A - a)}{200A + t_w d_w} \right) \text{ cm}^3$$

where

a = the area of the face plate of the member, in cm^2

d_w = the depth, in mm, of the web between the inside of the face plate and the attached plating. Where the member is at right angles to a line of corrugations, the minimum depth is to be taken

t_w = the thickness of the web of the section, in mm

A = the area, in cm^2 , of the attached plating, see Pt 3, Ch 3, 3.2 Geometric properties of section 3.2.7. If the calculated value of A is less than the face area a , then A is to be taken as equal to a .

3.2.7 The geometric properties of primary support members (i.e. girders, transverses, webs, stringers, etc.) are to be calculated in association with an effective area of attached load bearing plating, A , determined as follows:

(a) For a member attached to plane plating:

$$A = 10fbt_p \text{ cm}^2$$

- (b) For a member attached to corrugated plating and parallel to the corrugations:

$$A = 10bt_p \text{ cm}^2$$

See Figure 3.3.1 Corrugation dimensions

- (c) For a member attached to corrugated plating and at right angles to the corrugations:

A = is to be taken as equivalent to the area of the face plate of the member.

3.3 Determination of span point

3.3.1 The effective length, l_e , of a stiffening member is generally less than the overall length, l , by an amount which depends on the design of the end connections. The span points, between which the value of l_e is measured, are to be determined as follows:

- (a) For rolled or built secondary stiffening members:

The span point is to be taken at the point where the depth of the end bracket, measured from the face of the secondary stiffening member is equal to the depth of the member. Where there is no end bracket, the span point is to be measured between primary member webs. For double skin construction, the span may be reduced by the depth of primary member web stiffener, see Figure 3.3.3 Span points.

- (b) For primary support members:

The span point is to be taken at a point distant from the end of the member,

$$\text{where } l_e = b_b \left(1 - \frac{d_w}{d_b} \right)$$

See also Figure 3.3.3 Span points.

3.3.2 Where the end connections of longitudinals are designed with brackets to achieve compliance with the *ShipRight FDA procedure*, no reduction in span is permitted for such brackets unless the fatigue life is subsequently re-assessed and shown to be adequate for the resulting reduced scantlings.

3.3.3 Where the stiffener member is inclined to a vertical or horizontal axis and the inclination exceeds 10°, the span is to be measured along the member.

3.3.4 It is assumed that the ends of stiffening members are substantially fixed against rotation and displacement. If the arrangement of supporting structure is such that this condition is not achieved, consideration will be given to the effective span to be used for the stiffener.

3.4 Calculation of hull section modulus

3.4.1 All continuous longitudinal structural material is to be included in the calculation of the inertia of the hull midship section, and the lever z is, except where otherwise specified for particular ship types, to be measured vertically from the neutral axis to the top of keel and to the moulded strength deck line at the side. The strength deck is to be taken as follows:

- (a) Where there is a complete upper deck and no effective superstructure, the strength deck is the upper deck.
 (b) Where the upper deck is stepped, as in the case of raised quarterdeck ships, or there is an effective superstructure on the upper deck, the strength deck is stepped as shown in Figure 3.3.4 Strength deck stepping.

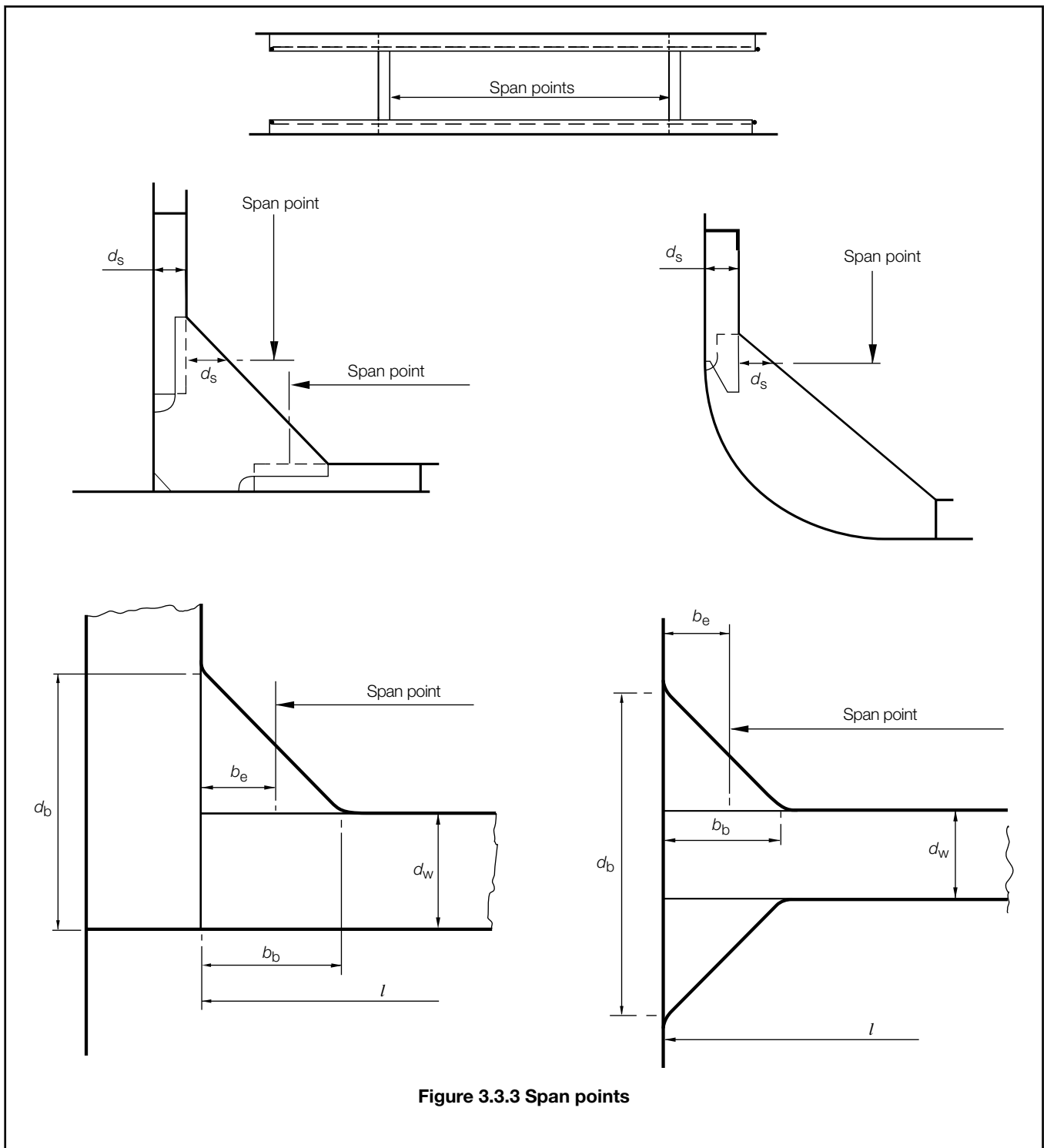

Figure 3.3.3 Span points

3.4.2 An effective superstructure is one which exceeds $0,15L$ in length and extends inside the midship $0,5L$ region. Superstructure decks less than 12 m in length are not to be considered as strength deck.

3.4.3 Openings having a length in the fore and aft directions exceeding 2,5 m or $0,1B$ m or a breadth exceeding 1,2 m or $0,04B$ m, whichever is the lesser, are always to be deducted from the sectional areas used in the section modulus calculation.

3.4.4 Smaller openings (including manholes, lightening holes, single scallops in way of seams, etc.) need not be deducted provided they are isolated and the sum of their breadths or shadow area breadths (see Pt 3, Ch 3, 3.4 Calculation of hull section modulus 3.4.7), in one transverse section does not reduce the section modulus at deck or bottom by more than 3 per cent.

3.4.5 Where B_1 equals the breadth of the ship at the section considered and Σb_1 equals the sum of breadths of deductible openings, the expression $0,06 (B_1 - \Sigma b_1)$ may be used for deck openings in lieu of the 3 per cent limitation of reduction of section modulus in Pt 3, Ch 3, 3.4 Calculation of hull section modulus 3.4.4.

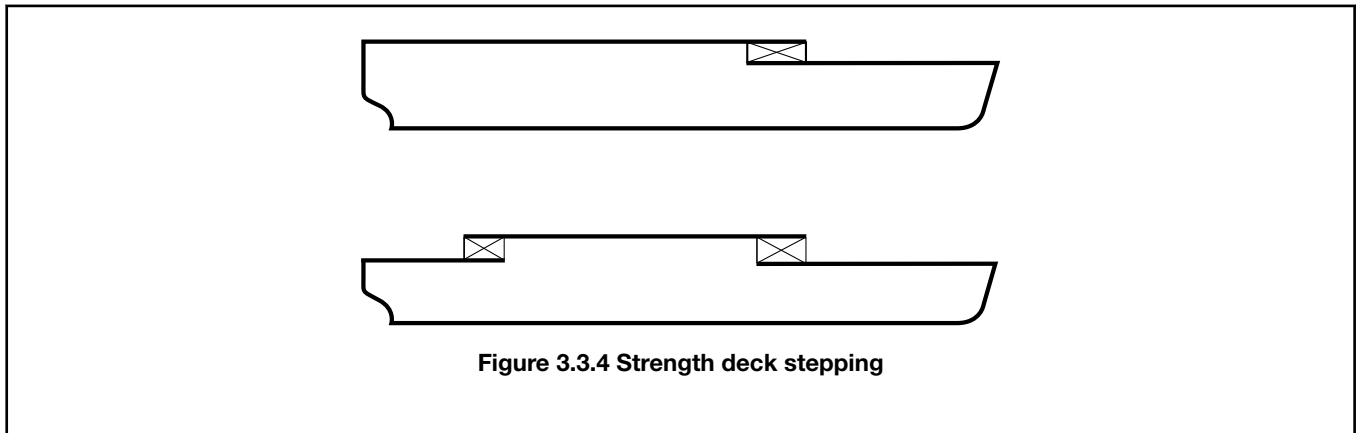

3.4.6 Where a large number of openings are proposed in any transverse space, special consideration will be required.

3.4.7 When calculating deduction-free openings, the openings are assumed to have longitudinal extensions as shown by the shaded areas in Figure 3.3.5 Deduction free openings shadow areas. The shadow area is obtained by drawing two tangent lines to an opening angle of 30° . The section to be considered should be perpendicular to the centreline of the ship and should result in the maximum deduction in each transverse space.

3.4.8 Isolated openings in longitudinals or longitudinal girders need not be deducted if their depth does not exceed 25 per cent of the web depth with a maximum depth for scallops of 75 mm.

3.4.9 Openings are considered isolated if they are spaced not less than 1 m apart.

3.4.10 For compensation that may be required for openings, see individual ship Chapters.

3.4.11 Where trunk decks or continuous hatch coamings are effectively supported by longitudinal bulkheads or deep girders, they are to be included in the longitudinal sectional area when calculating the hull section modulus. The lever z_t is to be taken as:

$$z_t = z_c(0,9 + 0,2 \frac{y}{B}) \text{ m but not less than } z$$

y = horizontal distance from top of continuous strength member to the centreline of the ship, in metres

z = vertical distance from the neutral axis to the moulded deck line at side, in metres

z_c = vertical distance from the neutral axis to the top of the continuous strength member, in metres

z_c and y are to be measured to the point giving the largest value of z_t .

3.4.12 Where continuous hatch coamings are effectively supported (except inboard coamings of multi-hatch arrangements, see Pt 3, Ch 3, 3.4 Calculation of hull section modulus 3.4.14), 100 per cent of their sectional area may be included in the calculation of the hull section modulus.

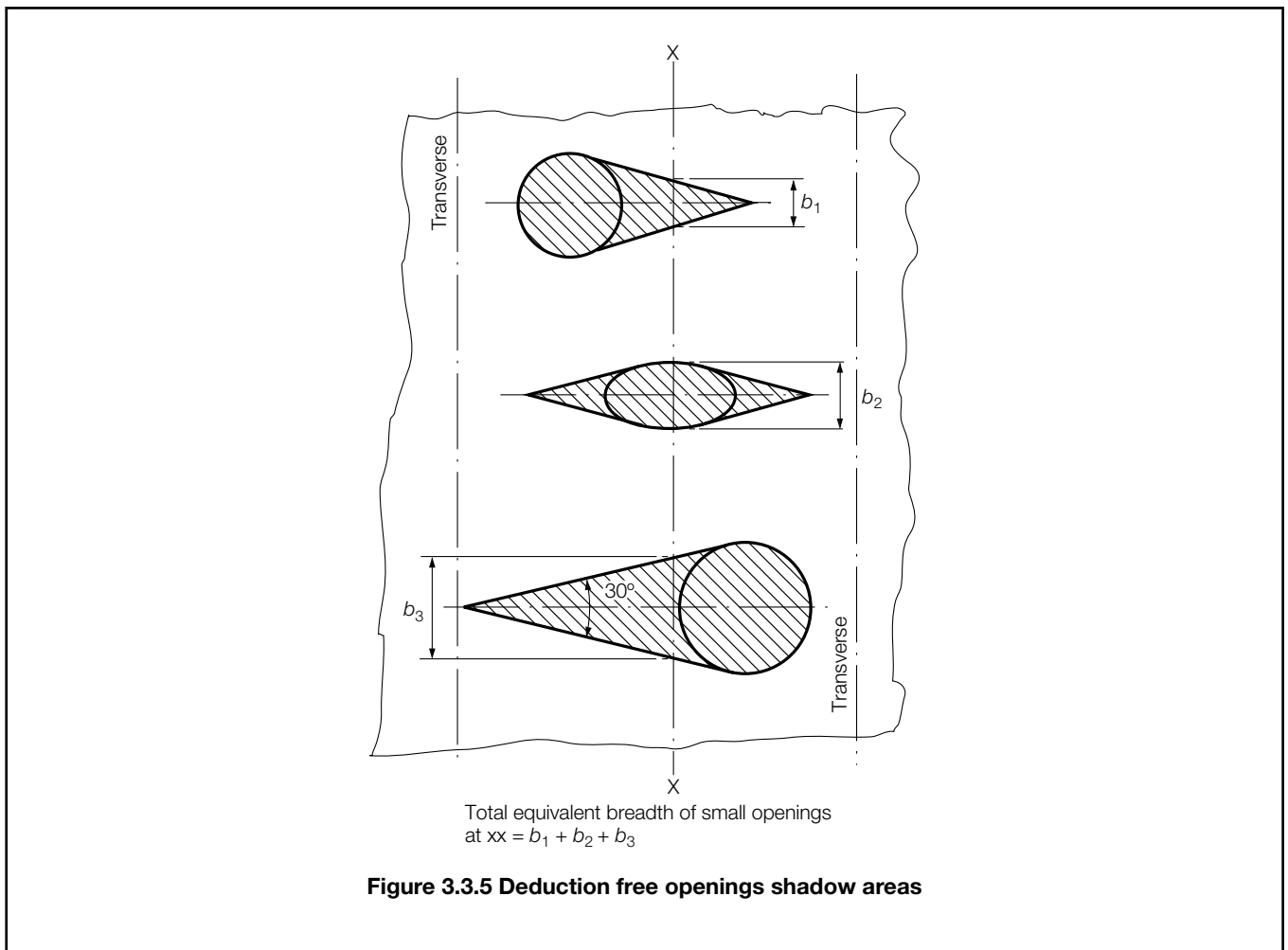

3.4.13 Where a continuous longitudinal underdeck girder, or girders, are arranged to support the inboard hatch coamings, 50 per cent of their sectional area may be included. If the girder is fitted in conjunction with a longitudinal centreline bulkhead, 100 per cent of the sectional area may be included. In cases where the girders are enclosed box sections, or where the girders are effectively tied to the bottom structure, the area to be included will be specially considered.

3.4.14 The percentage of the sectional area to be included for inboard continuous hatch side coamings should be the same percentage as that of the longitudinal girder under.

3.4.15 Where continuous deck longitudinals or deck girders are arranged above the strength deck, the sectional area may be included in the calculation of the hull section modulus. The lever is to be taken to a position corresponding to the depth of the longitudinal member above the moulded deckline at side amidships.

■ *Section 4*
Bulkhead requirements

4.1 Number and disposition of bulkheads

4.1.1 All ships are to have a collision bulkhead, an after peak bulkhead, generally enclosing the sterntubes in a watertight compartment, and a watertight bulkhead at each end of the machinery space. Additional watertight bulkheads are to be fitted so that the total number of bulkheads is at least in accordance with *Table 3.4.1 Total number of bulkheads*.

Table 3.4.1 Total number of bulkheads

Length, L , in metres	Total number of bulkheads	
	Machinery amidships	Machinery aft, see Note
≤ 65	4	3
$> 65 \leq 85$	4	4
$> 85 \leq 90$	5	5
$> 90 \leq 105$	5	5
$> 105 \leq 115$	6	5
$> 115 \leq 125$	6	6
$> 125 \leq 145$	7	6
$> 145 \leq 165$	8	7
$> 165 \leq 190$	9	8
> 190	To be considered individually	

Note With after peak bulkhead forming after boundary of machinery space.

4.1.2 The bulkheads in the holds should be spaced at reasonably uniform intervals. Where non-uniform spacing is unavoidable and the length of a hold is unusually great, the transverse strength of the ship is to be maintained by fitting web frames, increased framing, etc. and details are to be submitted.

4.1.3 Proposals to dispense with one or more of these bulkheads will be considered, subject to suitable structural compensation, if they interfere with the requirements of a special trade.

4.1.4 Where applicable, the number and disposition of bulkheads are to be arranged to suit the requirements for subdivision, floodability and damage stability, and are to be in accordance with the requirements of the National Authority in the country in which the ship is registered.

4.2 Collision bulkhead

4.2.1 A collision bulkhead shall be fitted which shall be watertight up to the bulkhead deck. This bulkhead shall be located at a distance from the forward side of the stem, on the waterline on which L_L is measured, of not less than $0,05L_L$ or 10 m, whichever is the less, and, except as may be permitted by the Administration, not more than $0,08L_L$ or $0,05L_L + 3$ m, whichever is the greater.

4.2.2 Where any part of the ship below the waterline extends forward of the forward side of the stem, on the waterline on which L_L is measured, e.g. a bulbous bow, the distances stipulated in *Pt 3, Ch 3, 4.2 Collision bulkhead 4.2.1* are to be measured from a point either:

- (a) at the mid-length of such extension;
- (b) at a distance $0,015L_L$ forward of the forward side of the stem, on the waterline on which L_L is measured; or
- (c) at a distance 3 m forward of the forward side of the stem, on the waterline on which L_L is measured, whichever is the least.

4.2.3 No doors, manholes, access openings, ventilation ducts or any other openings shall be fitted in the collision bulkhead below the bulkhead deck.

4.3 After peak bulkhead

4.3.1 All ships are to have an after peak bulkhead generally enclosing the sterntube and rudder trunk in a watertight compartment. In twin screw ships where the bossing ends forward of the after peak bulkhead, the sterntubes are to be enclosed in suitable watertight spaces inside or aft of the shaft tunnels. The sterntubes are to be enclosed in watertight spaces of moderate volume. In passenger ships, the stern gland is to be situated in a watertight shaft tunnel or other watertight space separate from the stern tube compartment and of such volume that, if flooded by leakage through the stern gland, the bulkhead deck will not be submerged.

4.4 Height of bulkheads

4.4.1 The collision bulkhead is normally to extend to the uppermost continuous deck or, in the case of ships with combined bridge and forecastle or a long superstructure which includes a forecastle, to the superstructure deck. However, if a ship is fitted with more than one complete superstructure deck, the collision bulkhead may be terminated at the deck next above the freeboard deck. Where the collision bulkhead extends above the freeboard deck, the extension need only be to weathertight standards.

4.4.2 The after peak bulkhead may terminate at the first deck above the load waterline, provided that this deck is made watertight to the stern or to a watertight transom floor. In passenger ships, the after peak bulkhead is to extend watertight to the bulkhead deck. However, it may be stepped below the bulkhead deck provided the degree of safety of the ship as regards watertight subdivision is not thereby diminished.

4.4.3 The remaining watertight bulkheads are to extend to the freeboard deck. In passenger ships of restricted draught and all ships of unusual design, the height of the bulkheads will be specially considered.

4.5 Watertight recesses, flats and loading ramps

4.5.1 Watertight recesses in bulkheads are generally to be so framed and stiffened as to provide strength and stiffness equivalent to the requirements for watertight bulkheads.

4.5.2 In collision bulkheads, any recesses or steps in the bulkhead are to fall within the limits of bulkhead positions given in *Pt 3, Ch 3, 4.2 Collision bulkhead 4.2.1*. Where the bulkhead is extended above the freeboard deck or bulkhead deck, the extension need only be to weathertight standards. If a step occurs at that deck, the deck need also only be to weathertight standards in way of the step, unless the step forms the crown of a tank, see *Pt 4, Ch 1, 4 Deck structure*.

4.5.3 Where bow doors are fitted and a sloping loading ramp forms part of the extension of the collision bulkhead above the bulkhead deck the ramp shall be weathertight over its complete length. In cargo ships the part of the ramp which is more than 2,3 m above the bulkhead deck may extend forward of the limit specified in *Pt 3, Ch 3, 4.2 Collision bulkhead 4.2.1* or *Pt 3, Ch 3, 4.2 Collision bulkhead 4.2.2*. Ramps not meeting the above requirements shall be disregarded as an extension of the collision bulkhead.

4.5.4 The number of openings in the extension of the collision bulkhead above the freeboard deck shall be restricted to the minimum compatible with the design and normal operation of the ship. All such openings shall be capable of being closed weathertight.

4.6 Longitudinal subdivision

4.6.1 When timber load lines are to be assigned, double bottom tanks within the midship half-length are to have adequate longitudinal subdivision.

4.7 Protection of tanks carrying fuel oil, lubricating oil, vegetable or similar oils

4.7.1 Tanks carrying fuel oil or lubricating oil are to be separated by cofferdams from those carrying feed water, fresh water, edible oil or similar oils. Similarly, tanks carrying vegetable or similar oils are to be separated from those carrying fresh or feed water.

4.7.2 Lubricating oil compartments are also to be separated by cofferdams from those carrying fuel oil. However these cofferdams need not be fitted provided that:

- (a) Common boundaries of lubricating oil and fuel oil tanks have full penetration welds.
- (b) The tanks are arranged such that the fuel oil tanks are not generally subjected to a head of oil in excess of that in the adjacent lubricating oil tanks.

4.7.3 Cofferdams are not required between fuel oil double bottom tanks and deep tanks above, provided that the inner bottom plating is not subjected to a head of fuel oil.

4.7.4 Where fitted, cofferdams are to be suitably ventilated.

4.7.5 If fuel oil tanks are necessarily located within or adjacent to the machinery spaces, their arrangement is to be such as to avoid direct exposure of the bottom from rising heat resulting from an engine room fire, see SOLAS 1974 as amended 2.2.3 *Oil fuel tanks*.

4.7.6 In passenger ships, water ballast is, in general, not to be carried in tanks intended for fuel oil. Attention is drawn to the Statutory Regulations issued by National Authorities in connection with the *MARPOL - International Convention for the Prevention of Pollution from Ships, 1973/78*.

4.7.7 For vessels which do not comply with the accidental fuel oil outflow performance standard given in MARPOL Annex 1, *Regulation 12A – Oil fuel tank protection*, fuel oil tanks are to be bounded by double bottom and double side tanks or void spaces such that the distance between the fuel oil tank boundary and the shell plating is not less than that given in *Table 3.4.2 Fuel oil tank boundary requirements* and *Figure 3.4.1 Fuel oil tank boundary lines*. For double hull oil tankers where the requirements of *Pt 4, Ch 9, 1.2 Application and ship arrangement 1.2.17* conflict with this requirement *Pt 4, Ch 9, 1.2 Application and ship arrangement 1.2.17* is to take precedent. Alternatively the accidental oil outflow performance standard specified in MARPOL Annex 1 *Regulation 12A – Oil fuel tank protection* may be complied with.

Table 3.4.2 Fuel oil tank boundary requirements

Fuel oil tank capacity (C), m ³	Minimum double side width (d _s) metres	Minimum double bottom depth (d _b) metres
C ≥ 5000	$d_s = 0,5 + \frac{C}{20000}$ or $d_s = 2,0$ whichever is the lesser, but not less than 1,0	$d_b = \frac{B}{20}$ or $d_b = 2,0$ whichever is the lesser, but not less than 0,76
600 ≤ C < 5000	$d_s = 0,4 + \frac{2,4C}{20000}$ or $d_s = 1,0$ whichever is the greater, see Note	$d_b = \frac{B}{20}$ or $d_b = 2,0$ whichever is the lesser, but not less than 0,76
C < 600	d _s = 0	d _b = 0
Symbols		
<p>C = the ship's total volume of fuel oil, including that of small fuel oil tanks, in m³, at 98 per cent tank filling</p> <p>d_b = the distance, in metres, between the bottom of the fuel oil tank and the moulded line of the bottom shell plating. In the turn of bilge area and at locations without a clearly defined turn of bilge, the fuel oil tank boundary line shall run parallel to the line of the midship flat bottom as shown in <i>Figure 3.4.2 Definition of d_b</i></p> <p>d_s = the distance, in metres, between the side of the fuel oil tank and the moulded line of the side shell plating, see <i>Figure 3.4.1 Fuel oil tank boundary lines</i></p>		
<p>Note 1. However, for individual tanks with an fuel oil capacity of less than 500 m³, the minimum distance is 0,76 m.</p> <p>Note 2. Fuel oil tanks with a maximum individual capacity not greater than 30 m³ need not comply with the requirements of this Table, provided the aggregate capacity of such excluded tanks is not greater than 600 m³.</p> <p>Note 3. Suction wells in fuel oil tanks may protrude into the double bottom below the boundary line defined by the distance d_b, provided that such wells are as small as practicable and the distance between the well bottom and the bottom shell plating is not less than 0,5d_b.</p>		

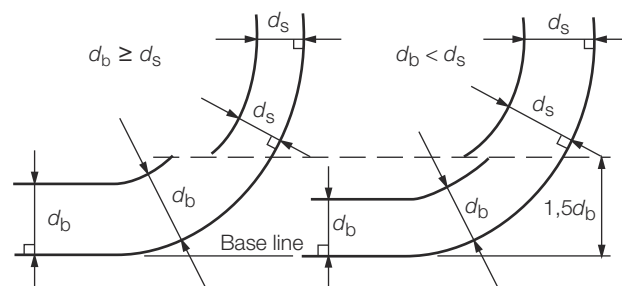
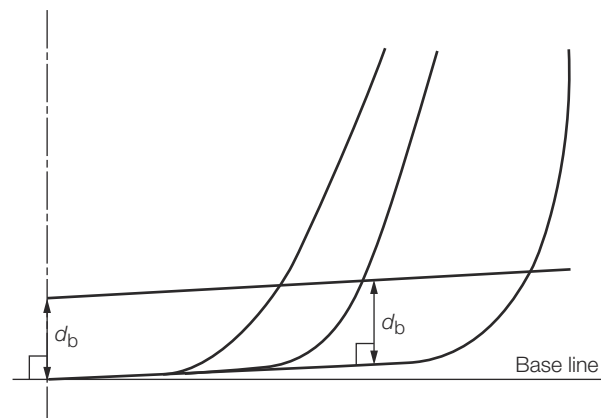

Figure 3.4.1 Fuel oil tank boundary lines

**Figure 3.4.2 Definition of d_b**

4.7.9 No individual fuel oil tank is to have a capacity greater than 2,500 m³.

4.8 Watertight tunnels and passageways

4.8.1 Where a machinery space is situated with a compartment or compartments between it and the after peak bulkhead, the shafting is to be enclosed in a watertight tunnel large enough to permit proper examination and repair of shafting. A sliding watertight door, capable of being operated locally from both sides, is to be provided at the forward end of the tunnel. Consideration may, however, be given to the omission of the watertight door, subject to satisfactory compliance with any relevant statutory requirements. Where two or more shafts are fitted, the tunnels shall be connected by an interconnecting passage. There shall be only one door between the machinery space and the tunnel spaces where two shafts are fitted and only two doors where there are more than two shafts.

4.8.2 Pipe tunnels are to have dimensions adequate for reasonable access.

4.8.3 Where fore and aft underdeck passageways are arranged at the ship's side, the after access thereto is to be by a watertight trunk led to the upper deck. Alternative arrangements to prevent the engine room being flooded, in the event of a collision or if the passageway doors are left open, will be considered.

4.9 Means of escape

4.9.1 For the requirements for means of escape, see SOLAS 1974 as amended *Regulation 13 - Means of escape*.

4.10 Oil tankers

4.10.1 For subdivision requirements within the cargo tank region for oil tankers, see *Pt 4, Ch 9, 1 General*.

■ Section 5 **Design loading**

5.1 General

5.1.1 This Section contains the design heads/pressures to be used in the derivation of scantlings for decks, tank tops and transverse bulkheads. These are given in *Table 3.5.1 Design heads and permissible cargo loadings*.

Table 3.5.1 Design heads and permissible cargo loadings

Structural item and position	Component	Standard stowage rate C , in $m^3/tonne$	Design loading p , in kN/m^2	Equivalent design head h_i in metres	Permissible cargo loading in kN/m^2	Equivalent permissible head, in metres
Design heads and permissible cargo loadings (SI units)						
Weather deck (general cargo)				h_1		
(a) Loading for minimum scantlings						
Forward of 0,075L from F.P.	Beams and longitudinals	1,39	12,73	1,8	8,5	1,2
	Primary structure		$29,64 + 14,41E$	$4,2 + 2,04E$		
Between 0,12L and 0,075L from F.P.	Beams and longitudinals	1,39	10,61	1,5	8,5	1,2
	Primary structure		$22,59 + 14,41E$	$3,2 + 2,04E$		
Aft of 0,12L from F.P.	Beams and longitudinals	1,39	$8,5 + 14,41E$	$1,2 + 2,04E$	8,5	1,2
	Primary structure					
(b) Specified cargo loading						
Forward of 0,075L from F.P.	Beams and longitudinals	1,39	$2,47p_a + 14,41E$ or as (a), whichever is larger (Note 1)	$0,35p_a + 2,04E$ (Note 1)	p_a	$0,14p_a$
	Primary structure		$3,5p_a + 14,41E$ or as (a), whichever is larger (Note 1)	$0,5p_a + 2,04E$ (Note 1)		
Between 0,12L and 0,075L from F.P.	Beams and longitudinals	1,39	$1,98p_a + 14,41E$ or as (a), whichever is larger (Note 1)	$0,28p_a + 2,04E$ (Note 1)	p_a	$0,14p_a$
	Primary structure		$2,67p_a + 14,41E$ or as (a), whichever is larger (Note 1)	$0,38p_a + 2,04E$ (Note 1)		
Aft of 0,12L from F.P.	Beams and longitudinals	1,39	$p_a + 14,41E$ (Note 1)	$0,14p_a + 2,04E$ (Note 1)	p_a	$0,14p_a$
	Primary structure					

Structural Design

Part 3, Chapter 3

Section 5

Cargo decks				h_2		
General cargo (standard loads)	All structure	1,39	$7,07H_{td}$	H_{td}	$7,07H_{td}$	H_{td}
Special cargo (specified loads)		C	p_a	$\frac{Cp_a}{9,82}$	p_a	$\frac{Cp_a}{9,82}$
Machinery space, workshop and stores		1,39	18,37	2,6	-	-
Ship stores		1,39	14,14	2,0	-	-
Accommodation decks (clear of tanks)	All structure	1,39	8,5	h_3	-	-
				1,2		
Superstructure decks (Note 2)				h_3		
1st tier	Beams and longitudinals	-	-	0,9	Where the deck is exposed to the weather, add $2,04E$	-
2nd tier				0,6		
3rd tier and above				0,4 5		
Decks forming crown of tunnels and deep tanks	Plating and stiffeners	C	$\frac{9,82h}{C}$ where $h = \frac{1}{2}$ height of stand pipe above crown	h_4	-	-
				h		
(c) Bulk carrier (see Pt 3, Ch 3, 1.1 Application 1.1.3) with topside tanks						
Weather deck outside line of hatchways in way of cargo hold region, when topside tanks empty	Beams and longitudinals	1,39	-	-	7,06h	$h =$ the lesser of (i) $0,22B$ (ii) $1,2 + 0,14 \frac{W_b}{A}$ where $W_b =$ weight of water ballast in the topside tank per frame space, in kN $A =$ Corresponding area, (m ²), of deck in way over one hold frame space
	Primary Structure	1,39	-	-		
Cargo hatch covers (standard loading)				h_H		
Steel cover	Webs, stiffeners and plating	1,39	$7,07H_{td}$	H_{td}	$7,07H_{td}$	H_{td}
Wood cover	-	1,39	-	-	$7,07H_{td}$	H_{td}
Inner bottom				H		

Ship without heavy cargo notation	Plating and stiffeners	1,39	—	—	9,82T	1,39T
Ship with heavy cargo notation		$C \text{ but } \leq 0,865$	$\frac{H}{C}$	H	$\frac{H}{C}$	H
Watertight bulkheads	Plating and stiffeners	0,975	$10,07h_4$	h_4 from Fig 3.5.2	—	—
Deep tank bulkhead	Plating and stiffeners	$C \text{ but } \leq 0,975$	$\frac{9,82h_4}{C}$	h_4 from Fig 3.5.2	—	—
Design heads and permissible cargo loadings (metric units)						
Weather deck (general cargo)				h_1		
(a) Loading for minimum scantlings						
Forward of 0,075L from F.P.	Beams and longitudinals	1,39	1,296	1,8	0,865	1,2
	Primary structure		$3,02 + 1,467E$	$4,2 + 2,04E$		
Between 0,12L and 0,075L from F.P.	Beams and longitudinals	1,39	1,08	1,5	0,865	1,2
	Primary structure		$2,30 + 1,467E$	$3,2 + 2,04E$		
Aft of 0,12L from F.P.	Beams and longitudinals	1,39	$0,865 + 1,467E$	$1,2 + 2,04E$	0,865	1,2
	Primary structure					
(b) Specified cargo loading						
Forward of 0,075L from F.P.	Beams and longitudinals	1,39	$2,5p_a + 1,467E$ or as (a), whichever is larger (Note 1)	$3,5p_a + 2,04E$ (Note 1)	p_a	$1,39p_a$
	Primary structure		$3,5p_a + 1,467E$ or as (a), whichever is larger (Note 1)	$4,87p_a + 2,04E$ (Note 1)		
Between 0,12L and 0,075L from F.P.	Beams and longitudinals	1,39	$2,0p_a + 1,467E$ or as (a), whichever is larger (Note 1)	$2,78p_a + 2,04E$ (Note 1)	p_a	$1,39p_a$
	Primary structure		$2,67p_a + 1,467E$ or as (a), whichever is larger (Note 1)	$3,71p_a + 2,04E$ (Note 1)		

Aft of 0,12L from F.P	Beams and longitudinals	1,39	$\rho_a + 1,467E$ (Note 1)	$1,39\rho_a + 2,04E$ (Note 1)	ρ_a	$1,39\rho_a$
	Primary structure		$\rho_a + 1,467E$ (Note 1)	$1,39\rho_a + 2,04E$ (Note 1)		
Cargo decks				h_2		
General cargo (standard loads)	All structure	1,39	$\frac{H_{td}}{1,39}$	H_{td}	$\frac{H_{td}}{1,39}$	H_{td}
Special cargo (specified loads)		C	ρ_a	$C\rho_a$	ρ_a	$C\rho_a$
Machinery space, workshop and stores		1,39	1,87	2,6	—	—
Ships store		1,39	1,44	2,0	—	—
Accommodation decks (clear of tanks)	All structure	1,39	0,865	h_3	—	—
				1,2		
Superstructure decks (Note 2)				h_3		
1st tier	Beams and longitudinals	—	—	0,9	Where the deck is exposed to the weather, add $2,04E$	—
2nd tier				0,6		
3rd tier and above				0,4 5		
Decks forming crown of tunnels and deep tanks	Plating and stationers	C	$\frac{h}{c}$	h_4	—	—
				h		
where $h = \frac{1}{2}$ height of stand pipe above crown						
(c) Bulk carrier (see Pt 3, Ch 3, 1.1 Application 1.1.3) with topside tanks						
Weather deck outside line of hatchways in way of cargo hold region, when topside tanks empty	Beams and longitudinals	1,39	—	—	$\frac{h}{1,39}$	$h =$ the lesser of (i) $0,22B$ (ii) $1,2 + 0,39\frac{W_b}{A}$ where $W_b =$ weight of water ballast in the topside tank per frame space, tonne-f $A =$ Corresponding area, (m ²), of deck in way over one hold frame space
	Primary Structure	1,39	—	—		
Cargo hatch covers (standard loading)				h_H		

Steel cover	Webs, stiffeners and plating	1,39	$\frac{H_{td}}{1,39}$	H_{td}	$\frac{H_{td}}{1,39}$	H_{td}
Wood cover	—	1,39	—	—	$\frac{H_{td}}{1,39}$	H_{td}
Inner bottom				H		
Ship without heavy cargo notation	Plating and stiffeners	1,39	—	—	T	1,39T
Ship with heavy cargo notation		C but $\leq 0,865$	$\frac{H}{C}$	H	$\frac{H}{C}$	H
Watertight bulkheads	Plating and stiffeners	0,975	$\frac{h_4}{0,975}$	h_4 from Fig. 3.5.2	—	—
Deep tank bulkhead	Plating and stiffeners	C but $\leq 0,975$	$\frac{h_4}{C}$	h_4 from Fig. 3.5.2	—	—

Note 1. In the case of beams and longitudinals, the equivalent design head is to be used in conjunction with the appropriate formulæ.

Note 2. For forecastle decks forward of 0,12L from F.P., see Weather decks.

Note 3. For hatch covers of non-CSR bulk carriers, ore carriers and combination carriers, see Pt 4, Ch 7, 12 Steel hatch covers.

Note 4. For hatch covers of ship types excluding non-CSR bulk carriers, ore carriers and combination carriers, see Pt 3, Ch 11, 2 Steel hatch covers.

Note 5. For pontoon hatch covers, see Pt 3, Ch 11, 2.17 Pontoon covers.

5.2 Symbols

5.2.1 The symbols used in this Section are defined as follows:

L , L_{pp} , C_b , B , D and T as defined in Pt 3, Ch 1, 6.1 Principal particulars

h_i = appropriate design head, in metres

l_e = span of stiffener

p = design loading, in kN/m² (tonne-f/m²)

p_a = applied loading, in kN/m² (tonne-f/m²)

C = stowage rate, in m³/tonne

= $\frac{h_i}{p}$ generally

= volume of the hold, in m³ excluding the volume contained within the depth of the cargo hatchway, divided by the weight of cargo, in tonnes, stowed in the hold, for inner bottom

E = correction factor for height of platform

= $\frac{0,0914 + 0,003L}{D - T} - 0,15$, but not less than zero nor more than 0,147

H = height from tank top to deck at side, in metres

H_c = 'tween deck height measured vertically on the centreline of the ship from 'tween deck to underside of hatch cover stiffeners on deck above, in metres

H_{td} = cargo head in 'tween deck, in metres, as defined in Figure 3.5.1 Heads for 'tween decks.

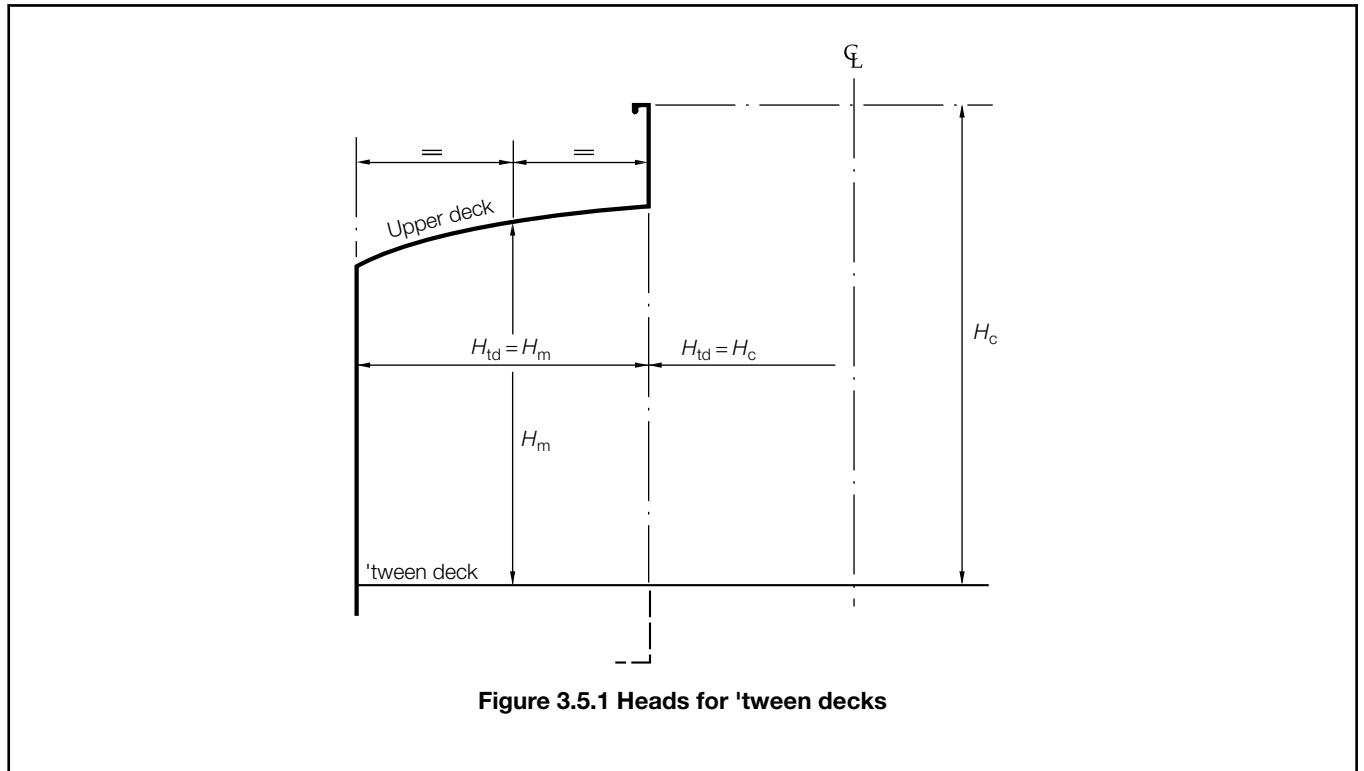
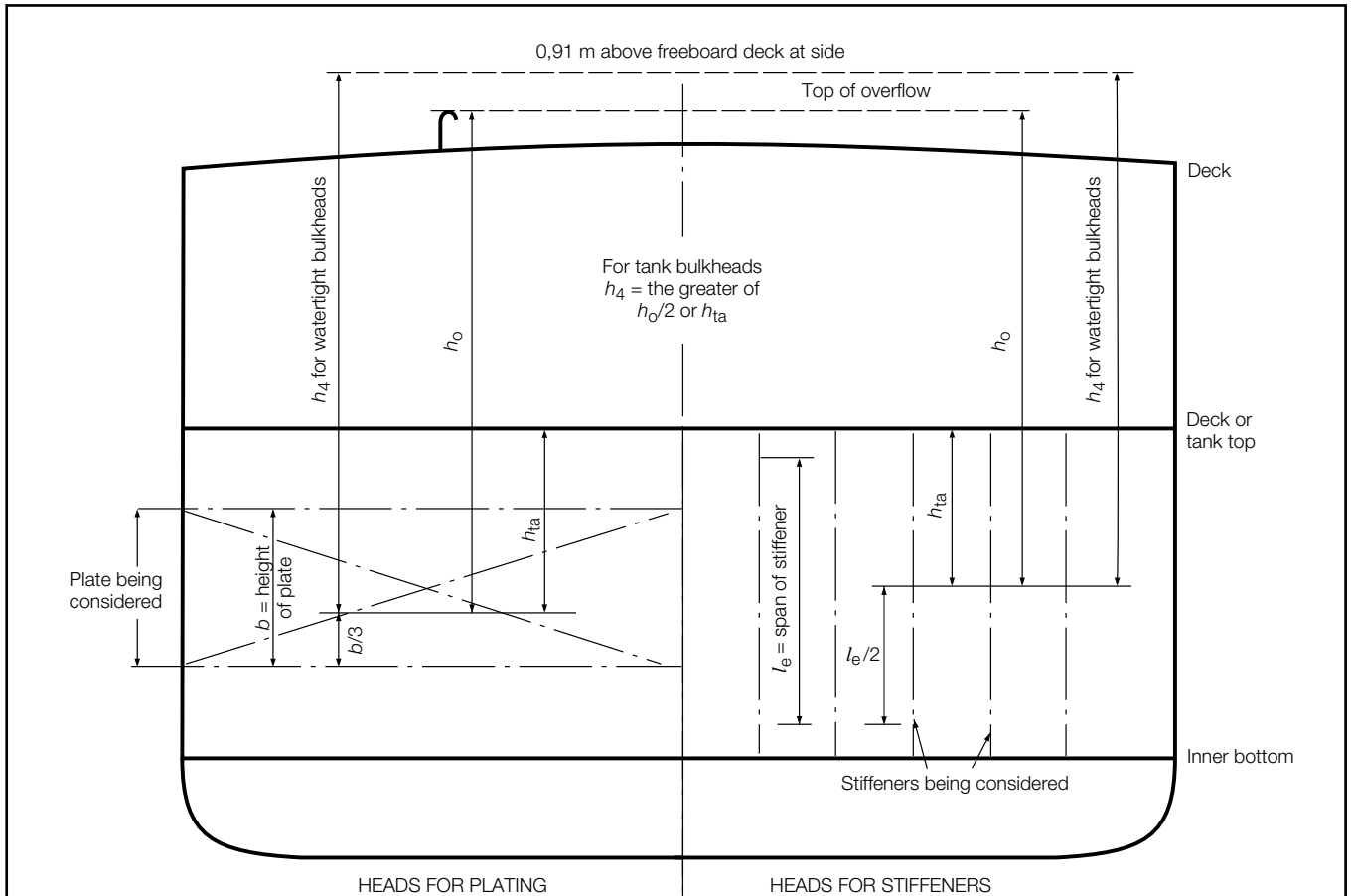
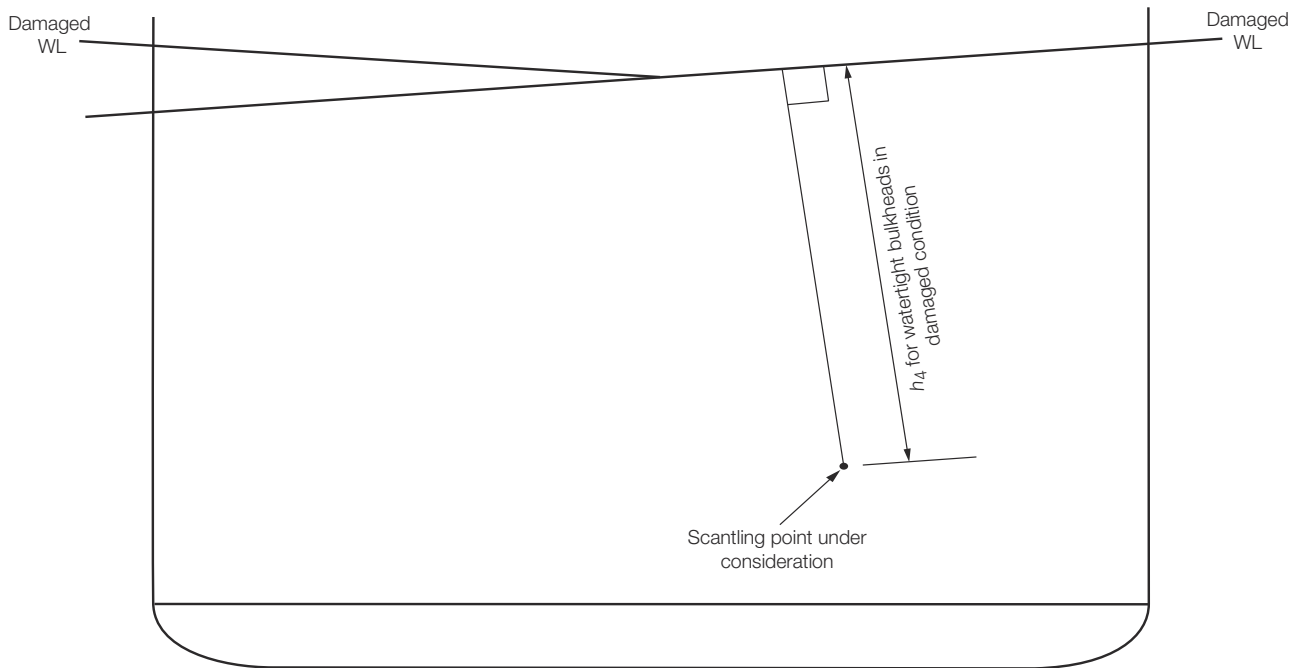

Figure 3.5.1 Heads for 'tween decks



(a) Heads for watertight and deep tank bulkheads in intact condition



(b) Heads for watertight bulkheads in damaged condition

Figure 3.5.2 Heads for watertight and deep tank bulkheads

5.2.2 The following symbols and definitions apply in particular to the design pressures for partially filled tanks:

L_{pp} and C_b as defined in Pt 3, Ch 1, 6.1 *Principal particulars*

b = height of internal primary bottom members, in metres

F = fill height, in metres

F_r = effective filling ratio

$$= \frac{\pi}{L_s} \left(F - b \sqrt{\frac{n}{n+1}} \right)$$

GM = transverse metacentric height, in metres, including free surface correction, for the loading condition under consideration

H_t = tank depth, in metres, measured from the bottom of the tank to the underside of the deck at side. In the case of holds, the depth is measured from the inner bottom to the underside of the deck at hatch side, except in double skin ships with hatch coaming in line with the inner skin, in which case, the depth is measured to the top of the hatch coaming

n = number of internal primary bottom members

L_s = the effective horizontal free surface length, in metres, in the direction of angular motion (i.e. tank breadth for roll, tank length for pitch)

S_{nr} = ship's natural rolling period

$$= \frac{2,35_r}{\sqrt{GM}} \text{ seconds}$$

= for ships for which either r or GM varies significantly between loading conditions (for example, bulk carriers and tankers, see Pt 3, Ch 3, 1.1 *Application 1.1.3*), S_{nr} should be evaluated for each representative loading condition considered

r = radius of gyration of roll, in metres, and may be taken as $0,34B$

S_{np} = ship's natural pitching period

$$= 3,5\sqrt{TC_b} \text{ seconds}$$

= for ships for which either T or C_b varies significantly between loading conditions (for example, bulk carriers and tankers, see Pt 3, Ch 3, 1.1 *Application 1.1.3*), S_{np} should be evaluated for each representative loading condition considered

T_{np} = fluid natural period of pitch

$$= \sqrt{\frac{4\pi L_s}{g \cdot \tanh(F_r)}} \text{ seconds}$$

T_{nr} = fluid natural period of roll

$$= \sqrt{\frac{4\pi L_s}{g \cdot \tanh(F_r)}} \text{ seconds}$$

θ_{max} = maximum 'lifetime' pitch angle, in degrees:

$$= (32,7 - 8,2C_b) e^{-0,001L_{pp}} (4,9 + 0,5C_b)$$

Φ_{max} = maximum 'lifetime' roll angle, in degrees:

$$= \left(14,8 + 3,7 \frac{L_{pp}}{B} \right) e^{-0,0023L_{pp}}$$

5.3 Stowage rate and design loads

5.3.1 Unless it is specifically requested otherwise, the following standard stowage rates are to be used:

- (a) 1,39 m³/tonne for weather or general cargo loading on deck and inner bottom.
- (b) 0,975 m³/tonne for liquid cargo of density of 1,025 tonne/m³ or less on watertight and tank divisions. For liquid of density greater than 1,025 tonne/m³ the corresponding stowage rates are to be adopted.

5.3.2 Proposals to use a stowage rate greater than 1,39 m³/tonne for permanent structure will require special consideration, and will normally be accepted only in the case of special purpose designs such as fruit carriers, etc.

5.3.3 The design head and permissible cargo loading are shown in *Table 3.5.1 Design heads and permissible cargo loadings*.

5.4 Design pressure for partially filled tanks

5.4.1 When partial filling of tanks or holds is contemplated for sea-going conditions, the risk of significant loads due to sloshing induced by any of the ship motions is to be considered. An initial assessment is to be made to determine whether or not a higher level of sloshing investigation is required, using the following procedure which corresponds to the Level 1 investigation outlined in the *SDA Procedure for Sloshing loads and scantling assessment*, on tanks partially filled with liquids.

5.4.2 In general, significant dynamic magnifications of the sloshing pressures are considered unlikely for the following cases:

- (a) For internally stiffened tanks:
 - (i) Where two (or more) deck girders (in the case of rolling) or deck transverses (in the case of pitching) are located not more than 25 per cent of the tank breadth or length respectively from the adjacent tank boundary, and the fill level is greater than the tank depth minus the height of the deck girders or transverses;
 - (ii) Where the deck girders or transverses, at any location, are less than 10 per cent of the tank depth, and the fill level is greater than the tank depth minus the height of the deck girders or transverses;
 - (iii) Where the fill level is less than the height of any bottom girders or transverses.
- (b) For smooth tanks:

where the fill level is less than 10 per cent or more than 97 per cent of the tank depth.

5.4.3 Significant dynamic magnification of the fluid motions, and hence the sloshing pressure, can occur if either of the following conditions exist:

- (a) The natural rolling period, T_{nr} , of the fluid and the ship's natural rolling period, S_{nr} , are within five seconds of each other.
- (b) The natural pitching period, T_{np} , of the fluid is greater than a value of three seconds below the ship natural pitching period, S_{np} .

These values define the limits of the critical fill range for each tank.

5.4.4 The critical fill range, F_{crit} , is to be determined using the following formula:

$$F_{crit} = \left(\frac{100}{H_t} \right) \left[\left(\frac{L_s}{2\pi} \right) \ln \left(\frac{1+\eta}{1-\eta} \right) + b \sqrt{\frac{n}{n+1}} \right] \%$$

where

\ln = natural logarithm to base e

$$\eta = \frac{4\pi L_s}{[(S_{nr} - 5)^2 g]} \text{ for fill level at } S_{nr} - 5 \text{ seconds upper bound roll critical fill level}$$

$$\text{or } \eta = \frac{4\pi L_s}{[(S_{nr} + 5)^2 g]} \text{ for fill level at } S_{nr} + 5 \text{ seconds lower bound roll critical fill level}$$

$$\text{or } \eta = \frac{4\pi L_s}{[(S_{np} - 3)^2 g]} \text{ for fill level at } S_{np} - 3 \text{ seconds upper bound pitch critical fill level}$$

where

$$\text{or } \eta = \frac{4 \pi L_s}{[(S_{np})^2 g]} \text{ for fill level at } S_{np} \text{ seconds}$$

The lower bound pitch critical fill level is 0,1 per cent fill. The value of F_{crit} is limited to the range 0 to 100 per cent, see also Pt 3, Ch 3, 5.4 Design pressure for partially filled tanks 5.4.6.

5.4.5 The natural periods of the ship for a given motion type are to be determined for the service loading conditions agreed between the Shipbuilder and Lloyd's Register. From this aspect, the storm-ballast and the segregated ballast conditions and the condition with all tanks partially filled could be the most critical.

5.4.6 When a ship is to be approved for Unrestricted Filling Levels - Unspecified Loading Conditions, many arbitrary ship loading conditions are possible. In order to cover the complete range of loading conditions, the fully loaded and ballast conditions are to be considered. These two conditions give an upper and lower limit for the possible range of natural periods of the ship as shown in Figure 3.5.3 Natural periods diagrams. Both the roll and pitch motion modes are to be examined.

Because of the unrestricted filling level requirement, the critical sloshing ranges extend from $[S_{nrBallast} - 5]$ to $[S_{nrLoaded} + 5]$ seconds in roll and from $[S_{npBallast} - 3]$ to $[S_{npLoaded}]$ in pitch. Also, because of unrestricted filling levels, the ship natural period range extends from $[S_{nBallast}]$ to $[S_{nLoaded}]$ for both pitch and roll.

For sloshing in the roll motion mode shown in Figure 3.5.3 Natural periods diagrams, the critical fill range extends from F_1 to F_4 . All fill levels between F_1 and F_4 are to be investigated:

- For fill levels between F_1 and F_2 , $S_{nrBallast}$ is to be used.
- For fill levels between F_3 and F_4 , $S_{nrLoaded}$ is to be used.
- For fill levels between F_2 and F_3 , S_{nr} is to be equal to T_{nr} .

Similarly, for sloshing in the pitch motion mode shown in Figure 3.5.3 Natural periods diagrams, the critical fill range extends from F_1 to F_4 . All fill levels between F_1 and F_4 are to be investigated.

- For fill levels between F_1 and F_2 , $S_{npBallast}$ is to be used.
- For fill levels between F_2 and F_3 , S_{np} is to be equal to T_{np} .
- For fill levels between F_3 and F_4 , $S_{np loaded}$ is to be used.

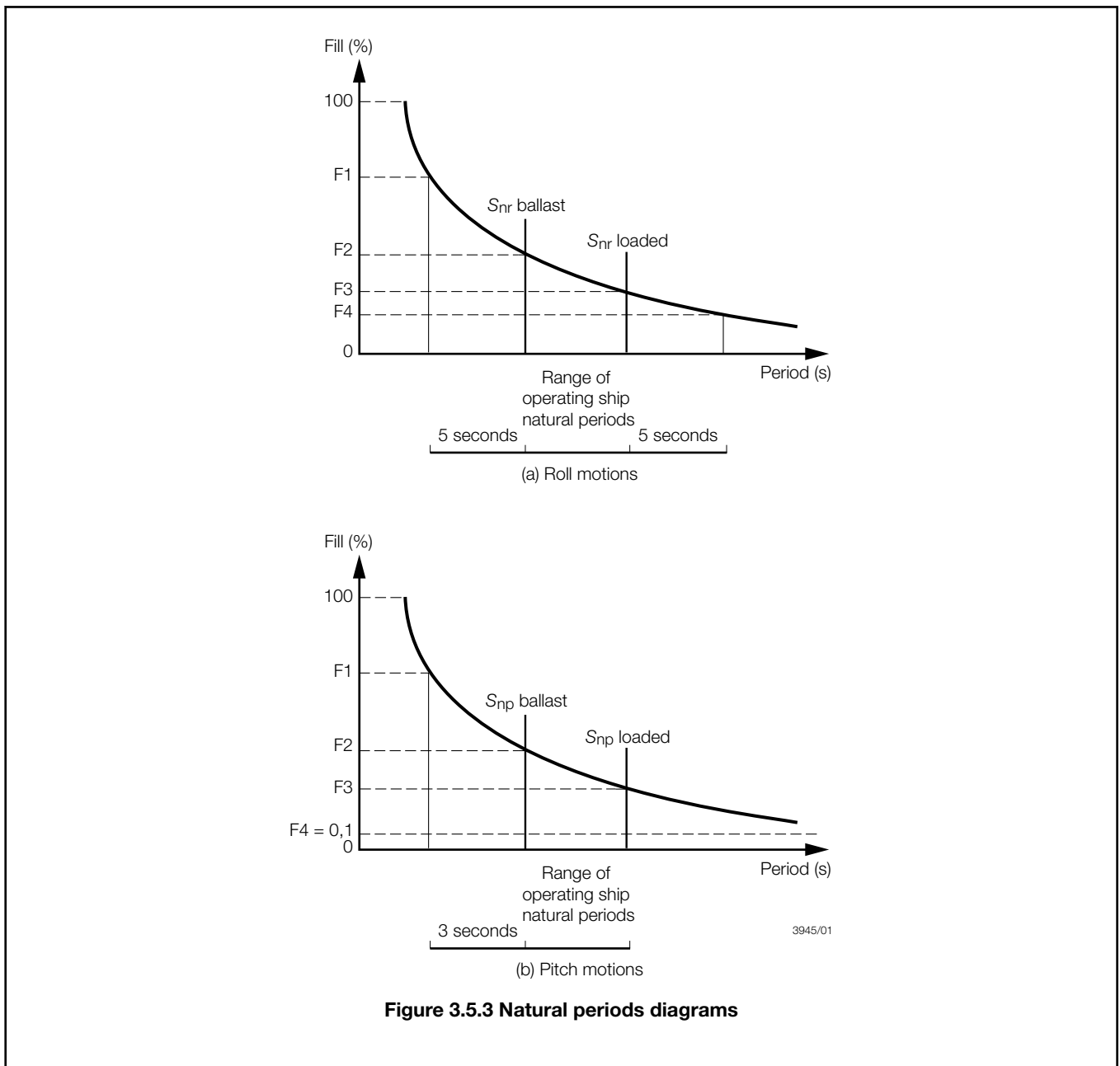

5.4.7 When a ship is to be approved for Restricted Filling Levels - Unspecified Loading Conditions, many arbitrary ship loading conditions are possible within the restrictions imposed. In order to cover the complete range of loading conditions, the fully loaded and ballast conditions are to be considered. These two conditions give an upper and lower limit for the possible range of ship natural period. It is recognised that there might be ship natural period bands which will not be applicable as a result of the limitations on the fill levels. However, it is recommended that the Unrestricted Filling Levels - Unspecified Loading Conditions procedure outlined in *Pt 3, Ch 3, 5.4 Design pressure for partially filled tanks 5.4.6* be applied.

5.4.8 When a ship is to be approved for Unrestricted Filling Levels - Specified Loading Conditions, each specified loading condition is to be examined for the complete fill ranges to determine the critical sloshing fill range for each tank in both roll and pitch motion modes.

5.4.9 When a ship is to be approved for Restricted Filling Levels - Specified Loading Conditions, each specified loading condition is to be examined for the restricted fill ranges to determine the critical sloshing fill range for each tank in both roll and pitch motion modes.

5.4.10 Where the assessment indicates that all the intended fill levels are outside the critical fill ranges and, therefore, significant sloshing will not occur, no further evaluation is required with regard to sloshing pressure. In such cases, the scantlings of the tank boundaries are to be determined in accordance with the relevant Rule requirements.

5.4.11 Where the separation of periods defined in *Pt 3, Ch 3, 5.4 Design pressure for partially filled tanks 5.4.3* is not met, other levels of assessment will be required as given in the *SDA Procedures for sloshing loads and scantling assessment*, on tanks partially filled with liquids.

5.4.12 The structural capability of the tank boundaries to withstand the dynamic sloshing pressures is to be examined. The magnitude of the predicted loads, together with the scantling calculations may be required to be submitted.

■ Section 6

Minimum bow heights, reserve buoyancy and extent of forecastle

6.1 Minimum bow heights

6.1.1 Ships are to comply with the Load Lines conventions, so far as these are applicable.

6.1.2 Bulk carriers, ore carriers and combination carriers are also to comply with the requirements of *Pt 4, Ch 7, Pt 4, Ch 7, 14 Forecastles*.

6.2 Extent of forecastle

6.2.1 Forecastles are to extend from the stem to a point at least $0,07L_L$ abaft the forward end of L_L (as defined in *Pt 3, Ch 1, 6.1 Principal particulars*). If the minimum bow height is obtained by increasing the sheer of the upper deck, the sheer is to extend for at least $0,15L_L$ abaft the forward end of L_L .

6.2.2 Bulk carriers, ore carriers and combination carriers are also to comply with the requirements of *Pt 4, Ch 7, 14 Forecastles*.

6.2.3 Forecastles are to be enclosed; that is with enclosing bulkheads of efficient construction and access openings complying with *Pt 3, Ch 11 Closing Arrangements for Shell, Deck and Bulkheads* and all other openings in sides or ends fitted with efficient weathertight means of closing.

Section

- 1 **Definitions**
- 2 **General**
- 3 **Application**
- 4 **Information required**
- 5 **Hull bending strength**
- 6 **Hull shear strength**
- 7 **Hull buckling strength**
- 8 **Loading guidance information**

■ *Section 1*
Definitions

1.1 List of symbols

1.1.1 The following symbols definitions are applicable to this Chapter, unless otherwise stated:

L, B, D, C_b = are as defined in Pt 3, Ch 1, 6.1 *Principal particulars*
and *V*

k_L, k = higher tensile steel factor, see Pt 3, Ch 2, 1.2 *Steel*

■ *Section 2*
General

2.1 Longitudinal strength calculations

2.1.1 Longitudinal strength calculations are to be carried out for all ships where L is greater than 65 m, covering the range of load and ballast conditions proposed, in order to determine the required hull girder strength. The calculations of still water shear forces and bending moments are to cover both departure and arrival conditions and any special mid-voyage conditions caused by changes in ballast distribution.

2.1.2 For ships where L is equal to or less than 65 m, longitudinal strength calculations may be required, dependent upon proposed loading.

2.1.3 Specific information regarding required loading conditions is given in the individual ship type Chapters.

2.2 Erections contributing to hull strength

2.2.1 In general, where a long superstructure or deckhouse of length greater than $0,15L$ is fitted, extending within the $0,5L$ amidships, the requirements for longitudinal strength in the hull and erection will be considered in each case.

2.3 Open type ships

2.3.1 For ships other than container ships which have large deck openings and where the structural configuration is such that warping stresses in excess of $14,7 \text{ N/mm}^2$ are likely to occur, local increases in section modulus, based normally on the combined stress diagram undertaken for container ships, may be required. For calculations for container ships, see Pt 4, Ch 8, 3 *Longitudinal strength*.

2.3.2 For ships with large deck openings such as containerships, sections at or near to the aft and forward quarter length positions are to be checked. For such ships with cargo holds aft of the superstructure, deckhouse or engine room, strength checks of sections in way of the aft end of the aft-most holds, and the aft end of the deckhouse or engine room are to be performed.

2.4 Ships with large flare

2.4.1 In ships of length between 120 and 170 m and maximum service speed greater than 17,5 knots, in association with a bow shape factor of more than 0,15, the Rule hull midship section modulus and the distribution of longitudinal material in the forward half-length will be specially considered, see *Pt 4, Ch 1, 3 Longitudinal strength*.

2.5 Direct calculation procedures

2.5.1 In direct calculation procedures capable of deriving the wave induced loads on the ship, and hence the required modulus, account is to be taken of the ship's actual form and weight distribution.

2.5.2 Lloyd's Register's (hereinafter referred to as 'LR') direct calculation method involves derivation of response to regular waves by appropriate sea keeping software, short-term response to irregular waves using the sea spectrum concept, and long-term response predictions using statistical distributions of sea states. Other direct calculation methods submitted for approval should normally contain these three elements and produce similar and consistent results when compared with LR's methods.

2.6 Approved calculation systems

2.6.1 Where the assumptions, method and procedures of a longitudinal strength calculation system have received general approval from LR, calculations using the system for a particular ship may be submitted.

■ Section 3 Application

3.1 Symbols

3.1.1 The symbols used in this Section are defined as follows:

b = breadth, in metres, of the hatch opening. Where there are multiple openings abreast, these are regarded as a single opening, and b is to be the sum of the individual breadths of these openings

l_H = length of the hatch opening, in metres

l_{BH} = distance, in metres, between centres of the deck strip at each end of the hatch opening. Where there is no further opening beyond the one under consideration, the point to which l_{BH} is measured will be considered, see also *Figure 4.3.1 Deck opening size*

B_1 = extreme breadth of deck including hatch opening, measured at the mid-length of the opening, in metres.

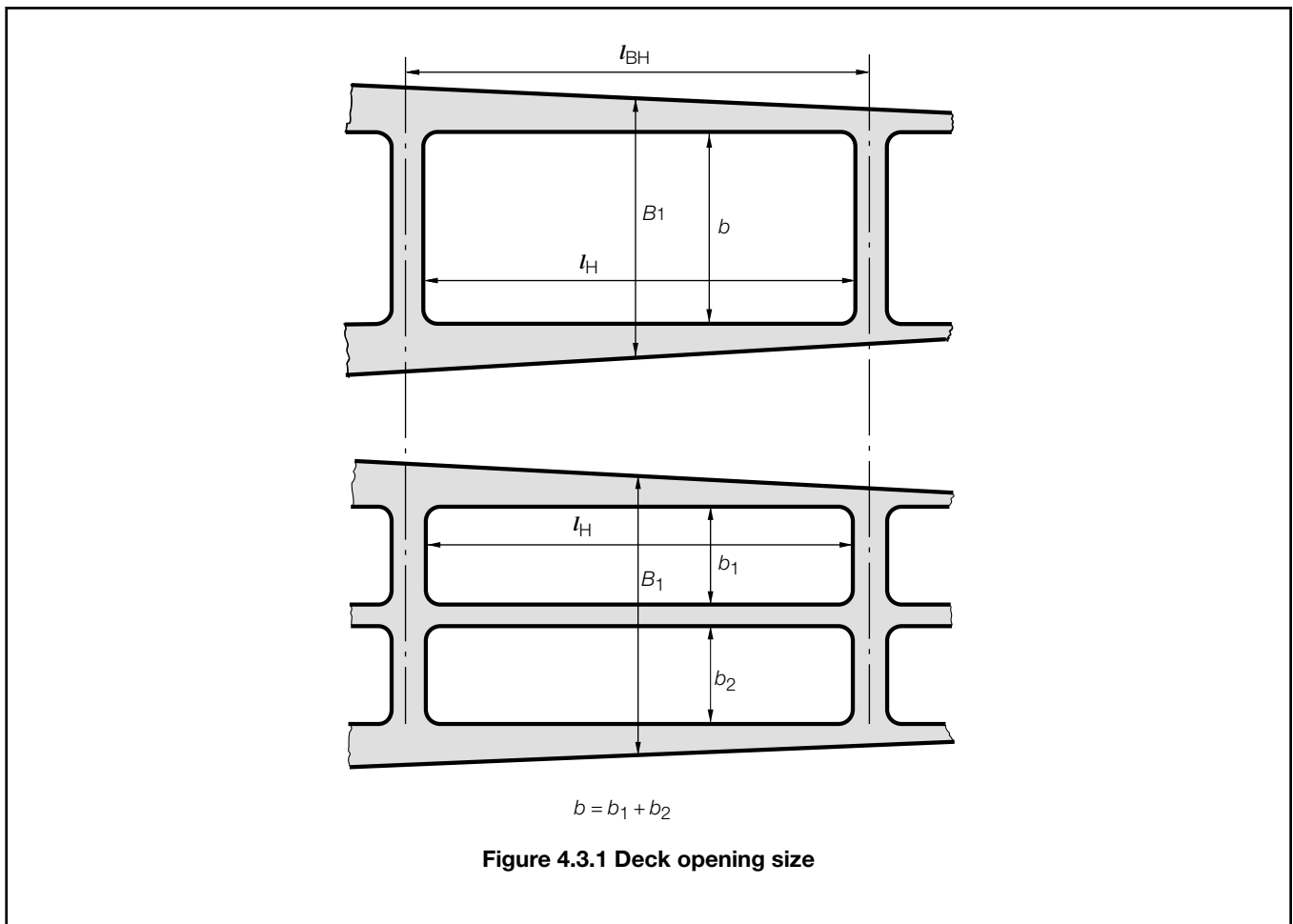

3.2 General

3.2.1 The requirements of this Chapter apply to sea-going steel ships, of normal form, proportions and speed, unless direct calculation procedures are adopted, in which case the assumptions made and the calculations performed are to be submitted for approval.

3.2.2 The requirements in this Chapter are not applicable to Double Hull Oil Tankers or Bulk Carriers with a **CSR** notation. See *Pt 1, Ch 2, 2.3 Class notations (hull)*.

3.3 Exceptions

3.3.1 Individual consideration based on direct calculation procedures will generally be required for ships having one or more of the following characteristics:

- Length L greater than 400 m.
- Speed V greater than that defined in *Table 4.3.1 Ship speed criteria* for the associated block coefficient.
- Unusual type or design.
- Unusual hull weight distribution.
- $\frac{L}{B} \leq 5$, or $\frac{B}{D} \geq 2,5$
- Large deck openings, or where warping stresses in excess of $14,7 \text{ N/mm}^2$ ($1,5 \text{ kgf/mm}^2$) are likely to occur.
- Openings for side loading in way of both sheerstrake and stringer.
- $C_b < 0,6$
- Carriage of heated cargo, see *Pt 4, Ch 9, 12 Cargo temperatures*.

Table 4.3.1 Ship speed criteria

Ship length L, m	C_b	Speed, knots
≤ 200	$> 0,80$	17
	$= 0,70$	19,5
	$< 0,60$	22
> 200	$> 0,80$	18
	$= 0,70$	21,5
	$< 0,60$	25

NOTE
Intermediate values of speed to be obtained by linear interpolation for C_b

3.3.2 A ship is regarded as having large deck openings if both the following conditions apply to any one opening:

$$\frac{b}{B_1} > 0,6$$

$$\frac{l_H}{l_{BH}} > 0,7$$

See also Figure 4.3.1 Deck opening size.

■ Section 4 Information required

4.1 List of requirements

4.1.1 In order that an assessment of the longitudinal strength requirements can be made, the following information is to be submitted, in LR's standard format where appropriate.

- (a) General arrangement and capacity plan or list, showing details of the volume and position of centre of gravity of all tanks and compartments.
- (b) Bonjean data, in the form of tables or curves, for at least 21 equally spaced stations along the hull. A lines plan and/or tables of offsets may also be required.
- (c) Details of the calculated lightweight and its distribution.
- (d) Loading Manual.
- (e) Details of the weights and centres of gravity of all deadweight items for each of the main loading conditions for individual ship types specified in *Pt 4 Ship Structures (Ship Types)*. It is recommended that this information be submitted in the form of a preliminary Loading Manual, and that it includes the calculated still water bending moments and shear forces.

4.1.2 For final Loading Manual, see *Pt 3, Ch 4, 8 Loading guidance information*.

■ Section 5 Hull bending strength

5.1 Symbols

5.1.1 The symbols used in this Section are defined as follows:

f_1 = ship service factor

f_2 = wave bending moment factor

F_B = local scantling reduction factor for hull members below the neutral axis, see Pt 3, Ch 4, 5.7 Local reduction factors

F_D = local scantling reduction factor for hull members above the neutral axis, see Pt 3, Ch 4, 5.7 Local reduction factors

I_{min} = minimum moment of inertia, of the hull midship section about the transverse neutral axis, in m^4

M_s = design still water bending moment, sagging (negative) and hogging (positive), in kN m (tonne-f m), to be taken negative or positive according to the convention given in Pt 3, Ch 4, 5.3 Design still water bending moments 5.3.2

\overline{M}_s = maximum permissible still water bending moment, sagging (negative) and hogging (positive), in kN m (tonne-f m), see Pt 3, Ch 4, 5.4 Minimum hull section modulus

M_w = design hull vertical wave bending moment amidships, sagging (negative) and hogging (positive), in kN m (tonne-f m), to be taken negative or positive according to the convention given in Pt 3, Ch 4, 5.3 Design still water bending moments 5.3.2

Z_C = actual hull section modulus, in m^3 , at continuous strength member above strength deck, calculated with the lever specified in Pt 3, Ch 3, 3.4 Calculation of hull section modulus

Z_D, Z_B = actual hull section moduli, in m^3 , at strength deck and keel respectively, see Pt 3, Ch 3, 3.4 Calculation of hull section modulus

Z_{min} = minimum hull midship section modulus about the transverse neutral axis, in m^3

σ = permissible combined stress (still water plus wave), in N/mm^2 (kgf/mm^2), see Pt 3, Ch 4, 5.5 Permissible still water bending moments

σ_D, σ_B = maximum hull vertical bending stress at strength deck and keel respectively, in N/mm^2 (kgf/mm^2)

z = vertical distance from the hull transverse neutral axis to the position considered, in metres

z_M = vertical distance, in metres, from the hull transverse neutral axis to the minimum limit of higher tensile steel, as defined in Pt 3, Ch 3, 2.6 Vertical extent of higher tensile steel, above or below the neutral axis as appropriate.

5.2 Design vertical wave bending moments

5.2.1 The appropriate hogging or sagging design hull vertical wave bending moment at amidships is given by the following:

$$M_w = f_1 f_2 M_{w0}$$

where

C_b = is to be taken not less than 0,60

C_1 = is given in Table 4.5.1 Wave bending moment factor

C_2 = 1, (also defined in Pt 3, Ch 4, 5.2 Design vertical wave bending moments 5.2.2 at other positions along the length L)

f_1 = ship service factor. To be specially considered depending upon the service restriction and in any event should be not less than 0,5. For unrestricted sea-going service $f_1 = 1,0$

f_2 = -1,1 for sagging (negative) moment

where

$$f_2 = \frac{1,9C_b}{(C_b + 0,7)} \text{ for hogging (positive) moment}$$

$$M_{wo} = 0,1C_1 C_2 L^2 B (C_b + 0,7) \text{ kN m}$$

$$= (0,0102C_1 C_2 L^2 B (C_b + 0,7) \text{ tonne-f m})$$

Consideration will be given to direct calculations of long-term vertical wave bending moments, see Pt 3, Ch 4, 2.6 Approved calculation systems.

Table 4.5.1 Wave bending moment factor

Length L , in metres	Factor C_1
< 90	$0,0412L + 4,0$
90 to 300	$10,75 - \left(\frac{300 - L}{100}\right)1,5$
> 300 ≤ 350	10,75
> 350 ≤ 500	$10,75 - \left(\frac{L - 350}{150}\right)1,5$

5.2.2 The longitudinal distribution factor, C_2 , of wave bending moment is to be taken as follows:

- 0 at the aft end of L
- 1,0 between $0,4L$ and $0,65L$ from aft
- 0 at the forward end of L

Intermediate values are to be determined by linear interpolation.

5.2.3 For operation in sheltered water or short voyages, a higher permissible still water bending moment can be assigned based on a reduced vertical wave bending moment given by:

(a) For operating in sheltered water:

$$M_w = 0,5f_2 M_{wo}$$

(b) For short voyages:

$$M_w = 0,8f_2 M_{wo}$$

These expressions can only be used in the expression for permissible still water bending moment, see Pt 3, Ch 4, 5.4 Minimum hull section modulus, and the relevant loading conditions are to be included in the Loading Manual, see Pt 3, Ch 4, 8.1 General.

5.2.4 'Short voyages' are defined as voyages of limited duration in reasonable weather. 'Reasonable weather' and 'sheltered water' are defined in Pt 1, Ch 2, 2 Character of classification and class notations.

5.3 Design still water bending moments

5.3.1 The design still water bending moment, M_s , hogging and sagging is the maximum moment calculated from the loading conditions, given in Pt 3, Ch 4, 5.3 Design still water bending moments 5.3.3, and is to satisfy the following relationship:

$$|M_s| \leq |\overline{M}_s|$$

5.3.2 Still water bending moments are to be calculated along the ship length. For these calculations, downward loads are to be taken as positive values and are to be integrated in the forward direction from the aft end of L . Hogging bending moments are positive.

5.3.3 In general, the following loading conditions, based on amount of bunkers, fresh water and stores at departure and arrival, are to be considered.

-
- (a) General cargo ships, container ships, passenger ships, roll on-roll off ships and refrigerated cargo carriers:
- (i) Homogeneous loading conditions, at maximum draught.
 - (ii) Ballast conditions.
 - (iii) Special loading conditions, e.g. container or light load conditions at less than the maximum draught, heavy cargo, empty holds or non-homogeneous cargo conditions, deck cargo conditions, etc. where applicable.
- (b) Bulk carriers (see Pt 3, Ch 4, 3.2 General 3.2.2), ore carriers and combination carriers
- (i) For ships of length, L , less than 150 m:
 - Alternate hold loading conditions at maximum draught, where applicable.
 - Homogeneous loading conditions at maximum draught.
 - Ballast conditions, including intermediate conditions associated with ballast exchange at sea.
 - Special conditions, e.g. deck cargo conditions.
 - For combination carriers, the conditions as specified in (c) for oil tankers are also to be considered.
 - (ii) For ships of length, L , 150 m or above:
 - Alternate light and heavy cargo loading conditions at maximum draught, where applicable.
 - Homogeneous light and heavy cargo loading conditions at maximum draught.
 - Ballast conditions. Where vessels are designed with a ballast hold adjacent to topside wing, hopper and double bottom tanks, the structure design is to be such that the ballast hold can be filled with all adjacent tanks empty;
 - Short voyage conditions where the ship is loaded to maximum draught with reduced bunkers, where applicable.
 - Multiple port loading/unloading conditions, where applicable.
 - Deck cargo conditions, where applicable.
 - Typical loading and discharging sequences from commencement to end of cargo operation, for homogeneous, alternate and part load conditions, where applicable.
 - Typical sequences for exchange of ballast at sea, where applicable.
 - For combination carriers, the conditions as specified in (c) for oil tankers are also to be considered.
 - For bulk carriers, the conditions as specified in Pt 3, Ch 4, 5.4 Minimum hull section modulus for the relevant notation are also to be considered.
- (c) Oil tankers (see Pt 3, Ch 4, 3.2 General 3.2.2):
- (i) Homogeneous loading conditions (excluding dry and clean ballast tanks) and ballast or part loaded conditions.
 - (ii) Any specified non-uniform distribution of loading.
 - (iii) Mid-voyage conditions relating to tank cleaning or other operations where these differ significantly from the ballast conditions.
- (d) Chemical tankers:
- (i) Conditions as specified for oil tankers.
 - (ii) Conditions for high density or segregated cargo.
- (e) Liquefied gas carriers:
- (i) Homogeneous loading conditions for all approved cargoes.
 - (ii) Ballast conditions.
 - (iii) Cargo conditions where one or more tanks are empty or partially filled or where more than one type of cargo having significantly different densities is carried.
- (f) All ships:
- (i) Any other loading condition likely to result in high bending moments and/or shear forces (including docking conditions, as appropriate).

5.3.4 Where the amount and disposition of consumables at any intermediate stage of the voyage are considered more severe, calculations for such intermediate conditions are to be submitted in addition to those for departure and arrival conditions. Also where any ballasting and/or de-ballasting is intended during voyage, calculations of the intermediate condition just before and just

after ballasting and/or de-ballasting any tank are to be submitted and, where approved, included in the loading manual for guidance.

5.3.5 Ballast loading conditions involving partially filled peak and/or other ballast tanks at departure, arrival or during intermediate conditions are not permitted as design conditions unless the design stress limits are satisfied for all filling levels between empty and full, and for bulk carriers the requirements of *Pt 4, Ch 7, 3 Longitudinal strength*, as applicable, are to be complied with for all filling levels between empty and full. To demonstrate compliance with all filling levels between empty and full, it will be acceptable if, in each condition at departure, arrival and where required by *Pt 3, Ch 4, 5.3 Design still water bending moments 5.3.3*, any intermediate condition, the tanks intended to be partially filled are assumed to be:

- empty
- full
- partially filled at intended level.

Where multiple tanks are intended to be partially filled, all combinations of empty, full or partially filled at intended level for those tanks are to be investigated. However, for conventional ore carriers with large wing water ballast tanks in cargo area, where empty or full ballast water filling levels of one or maximum two pairs of these tanks lead to the ship's trim exceeding one of the following conditions, it is sufficient to demonstrate compliance with maximum, minimum and intended partial filling levels of these one or maximum two pairs of ballast tanks such that the ship's condition does not exceed any of these trim limits. Filling levels of all other wing ballast tanks are to be considered between empty and full. The trim conditions mentioned above are:

- trim by stern of 3 per cent of the ship's length, or
- trim by bow of 1.5 per cent of ship's length, or
- any trim that cannot maintain propeller immersion (I/D) not less than 25 per cent, where;

I = the distance from propeller centreline to the waterline, see *Figure 4.5.1 Propeller immersion*

D = propeller diameter, see *Figure 4.5.1 Propeller immersion*

The maximum and minimum filling levels of the above mentioned pairs of side ballast tanks are to be indicated in the loading manual.

5.3.6 When considering cargo loading conditions, the requirements of *Pt 3, Ch 4, 5.3 Design still water bending moments 5.3.5* apply to peak tanks only.

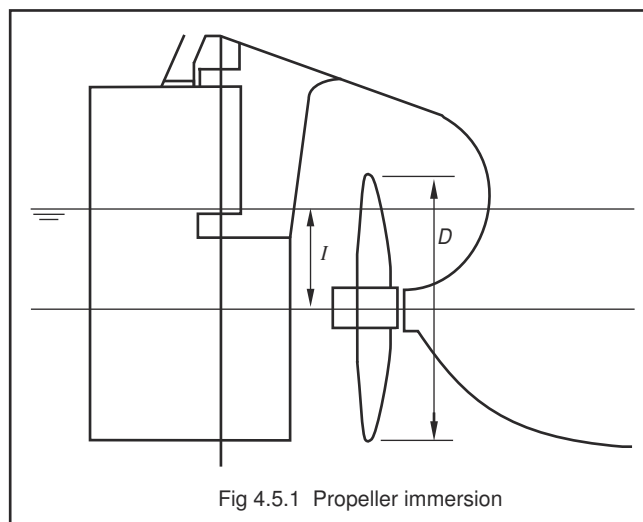

Figure 4.5.1 Propeller immersion

5.3.7 When considering ballast water exchange using the sequential method, the requirements of Pt 3, Ch 4, 5.3 Design still water bending moments 5.3.5 and Pt 3, Ch 4, 5.3 Design still water bending moments 5.3.6 do not apply. However, bending moment and shear force calculations for each de-ballasting or ballasting stage in the ballast water exchange sequence are to be included in the loading manual or ballast water management plan of any vessel that intends to employ the sequential ballast water exchange method.

5.4 Minimum hull section modulus

5.4.1 The hull midship section modulus about the transverse neutral axis, at the deck or the keel, is to be not less than:

$$\begin{aligned} Z_{\min} &= f_1 k_L C_1 L^2 B (C_b + 0,7) \times 10^{-6} \text{ m}^3 \\ &= \text{and } f_1 \text{ is to be taken not less than } 0,5. \end{aligned}$$

5.4.2 For materials to be included in the calculation of actual hull section properties, see Pt 3, Ch 3, 3 Structural idealisation.

5.4.3 The midship section modulus for ships with a service restriction notation is to be not less than half the minimum value required for unrestricted service.

5.4.4 Scantlings of all continuous longitudinal members of the hull girder based on the minimum section modulus requirements given in Pt 3, Ch 4, 5.4 Minimum hull section modulus 5.4.1 are to be maintained within 0,4L amidships. However, in special cases, based on consideration of type of ship, hull form and loading conditions, the scantlings may be gradually reduced towards the ends of the 0,4L part, bearing in mind the desire not to inhibit the vessel's loading flexibility.

5.4.5 Outside 0,4L amidships, as a minimum, hull girder bending strength checks are to be carried out at the following locations:

- (a) In way of the forward end of the engine room.
- (b) In way of the forward end of the foremost cargo hold.
- (c) At any locations where there are significant changes in hull cross-section.
- (d) At any locations where there are changes in the framing system.

5.5 Permissible still water bending moments

5.5.1 The permissible still water bending moments sagging and hogging are to be taken as the lesser of the following:

(a)
$$|\overline{M}_s| = F_D \sigma Z_D \times 10^3 - |M_w| \text{ kN m (tonne-f m)}$$

(b)
$$|\overline{M}_s| = F_B \sigma Z_B \times 10^3 - |M_w| \text{ kN m (tonne-f m)}$$

where

σ = the permissible combined stress in N/mm² (kgf/mm²) is given in Pt 3, Ch 4, 5.6 Permissible hull vertical bending stresses and F_D and F_B are defined in Pt 3, Ch 4, 5.7 Local reduction factors 5.7.2. M_w is the design wave bending moment, sagging or hogging as appropriate, in accordance with Pt 3, Ch 4, 5.2 Design vertical wave bending moments.

5.6 Permissible hull vertical bending stresses

5.6.1 The permissible combined (still water plus wave) stress for hull vertical bending, σ , is given by:

(a) Within 0,4L amidships

$$\sigma = \frac{175}{k_L} \text{ N/mm}^2 \left(\frac{17,84}{k_L} \text{ kgf/mm}^2 \right)$$

(b) for continuous longitudinal structural members outside 0,4L amidships

$$\begin{aligned} \sigma &= \left(75 + 543 \frac{d}{L} - 699 \left(\frac{d}{L} \right)^2 \right) \frac{1}{k_L} \text{ N/mm}^2 \\ \left(\sigma &= \left(75 + 543 \frac{d}{L} - 699 \left(\frac{d}{L} \right)^2 \right) \frac{0,102}{k_L} \text{ kgf/mm}^2 \right) \end{aligned}$$

where d is the distance, in metres, from the F.P. (for the fore end region) or from the A.P. (for the aft end region), as appropriate, to the location under consideration.

Special consideration will be given to increasing the permissible stress outside $0,4L$ amidships to

$$\frac{175}{k_L} \text{ N/mm}^2 \left(\frac{17,84}{k_L} \text{ kgf/mm}^2 \right)$$

provided that sufficient buckling checks are carried out.

5.6.2 The requirements for ships of special or unusual design and for the carriage of special cargoes will be individually considered.

5.7 Local reduction factors

5.7.1 The maximum hull vertical bending stresses at deck, σ_D , and keel, σ_B , are given by the following, using the appropriate combination of bending moments to give sagging and hogging stresses:

$$\sigma_D = \frac{|\overline{M}_s + M_w|}{Z_D} \times 10^{-3} \text{ N/mm}^2 (\text{kgf/mm}^2)$$

$$\sigma_B = \frac{|\overline{M}_s + M_w|}{Z_B} \times 10^{-3} \text{ N/mm}^2 (\text{kgf/mm}^2)$$

Where the ship is always in the hogging condition, the sagging bending moment is to be specially considered.

5.7.2 Where the maximum hull vertical bending stress at deck or keel is less than the permissible combined stress, σ , reductions in local scantlings within $0,4L$ amidships may be permitted. The reduction factors applicable in *Pt 4 Ship Structures (Ship Types)* are defined as follows:

(a) For hull members above the neutral axis

$$F_D = \frac{\sigma_D}{\sigma}$$

(b) For hull members below the neutral axis

$$F_B = \frac{\sigma_B}{\sigma}$$

In general, the values of σ_D and σ_B to be used are the greater of the sagging or hogging stresses, and F_D and F_B are not to be taken less than 0,67 for plating and 0,75 for longitudinal stiffeners.

5.7.3 Where higher tensile steel is used in the hull structure, the values of F_D and F_B for the mild steel part are to be taken as not less than $\frac{z}{z_M}$.

5.8 Hull moment of inertia

5.8.1 The hull midship section moment of inertia about the transverse neutral axis is to be not less than the following using the maximum total bending moment, sagging or hogging:

$$I_{\min} = \frac{3L(|\overline{M}_s + M_w|)}{k_L \sigma} \times 10^{-5} \text{ m}^4$$

where values of σ are given in *Pt 3, Ch 4, 5.6 Permissible hull vertical bending stresses 5.6.1*.

In addition for vessels with $L \geq 90$ m the hull midship section moment of inertia is not to be less than the following:

$$I_{\min} = 3C_1 L^3 B(C_b + 0,7) \times 10^{-8} \text{ m}^4$$

where C_1 is given in *Pt 3, Ch 4, 5.2 Design vertical wave bending moments 5.2.1*.

5.9 Continuous strength members above strength deck

5.9.1 Where trunk decks or continuous hatch coamings are effectively supported or deck longitudinals or girders are fitted above the strength deck, the modulus Z_c is to be not less than Z_{\min} . The scantling reduction factor, F_D , referred to strength deck

at side, is applicable and, in addition to the requirement given in *Pt 3, Ch 4, 5.5 Permissible still water bending moments 5.5.1*, the permissible still water bending moments, sagging and hogging, are not to exceed:

$$|\overline{M}_s| = \alpha Z_c \times 10^3 - |M_w| \text{ kN m (tonne-f m)}$$

where

M_w = is the design wave bending moment sagging or hogging, as appropriate, in accordance with *Pt 3, Ch 4, 5.2 Design vertical wave bending moments*.

■ Section 6 Hull shear strength

6.1 Symbols

6.1.1 The symbols used in this Section are defined as follows:

I = the inertia of the hull about the horizontal neutral axis at the section concerned, in cm^4

Az = the first moment, in cm^3 , about the neutral axis, of the area of the effective longitudinal members between the vertical level under consideration, and the vertical extremity of the effective longitudinal members, taken at the section under consideration

Q_s = design hull still water shear force, in kN (tonne-f), to be taken as negative or positive according to the convention given in *Pt 3, Ch 4, 6.4 Design still water shear force 6.4.2*

\overline{Q}_s = permissible hull still water shear force, in kN (tonne-f), see *Pt 3, Ch 4, 6.5 Permissible still water shear force*

Q_w = design hull wave shear force, in kN (tonne-f), to be taken as negative or positive according to the convention given in *Pt 3, Ch 4, 6.4 Design still water shear force 6.4.2*

τ = permissible combined shear stress (still water plus wave), in N/mm^2 (kgf/mm^2), see *Pt 3, Ch 4, 6.6 Permissible shear stress*

τ_A = design shear stress, in N/mm^2 (kgf/mm^2), as given in *Pt 3, Ch 4, 6.7 Design shear stress 6.7.1* for use in *Pt 3, Ch 4, 7.4 Design stress*.

6.2 General

6.2.1 For ships with length L greater than 65 m, the shear forces on the hull structure are to be investigated.

6.2.2 For L greater than 200 m, where double skin construction of the side shell in association with topside and hopper tanks is proposed, shear flow calculations may be required to be submitted.

6.2.3 Where shear flow calculation procedures, other than those available within ShipRight are employed, the requirements of *Pt 3, Ch 1, 3 Equivalents* are to be complied with.

6.2.4 For passenger ships, the assessment of permissible still water shear forces is to take into consideration the effectiveness of the continuous superstructures and the sizes and arrangements of window and door openings.

6.2.5 Where longitudinal bulkheads are perforated by cut-outs, the assessment of permissible still water shear forces is to take into consideration the loss of material.

6.3 Design wave shear force

6.3.1 The design hull wave shear force, Q_w , at any position along the ship is given by:

$$Q_w = K_1 K_2 Q_{w0} \text{ kN (tonne - f)}$$

where

$$Q_{wo} = 0,3C_1 LB (C_B + 0,7) \text{ kN}$$

$(0,0306C_1 LB (C_B + 0,7) \text{ tonne-f})$

and C_B is to be taken not less than 0,6

K_1 is to be taken as follows, see also Figure 4.6.1 Shear force factor K_1 :

(a) Positive shear force

$$\begin{aligned} K_1 &= 0 \text{ at aft end of } L \\ &= \frac{1,589C_b}{(C_b + 0,7)} \text{ between } 0,2L \text{ and } 0,3L \text{ from aft} \\ &= 0,7 \text{ between } 0,4L \text{ and } 0,6L \text{ from aft} \\ &= 1,0 \text{ between } 0,7L \text{ and } 0,85L \text{ from aft} \\ &= 0 \text{ at forward end of } L \end{aligned}$$

(b) Negative shear force

$$\begin{aligned} K_1 &= 0 \text{ at aft end of } L \\ &= -0,92 \text{ between } 0,2L \text{ and } 0,3L \text{ from aft} \\ &= -0,7 \text{ between } 0,4L \text{ and } 0,6L \text{ from aft} \\ &= \frac{-1,727C_B}{(C_B + 0,7)} \text{ between } 0,7L \text{ and } 0,85L \text{ from aft} \\ &= 0 \text{ at forward end of } L \\ &= \text{Intermediate values to be determined by linear interpolation} \end{aligned}$$

$$\begin{aligned} K_2 &= 1,0 \text{ for unrestricted sea-going service conditions} \\ &= 0,8 \text{ for short voyages} \\ &= 0,5 \text{ for operating in sheltered water.} \end{aligned}$$

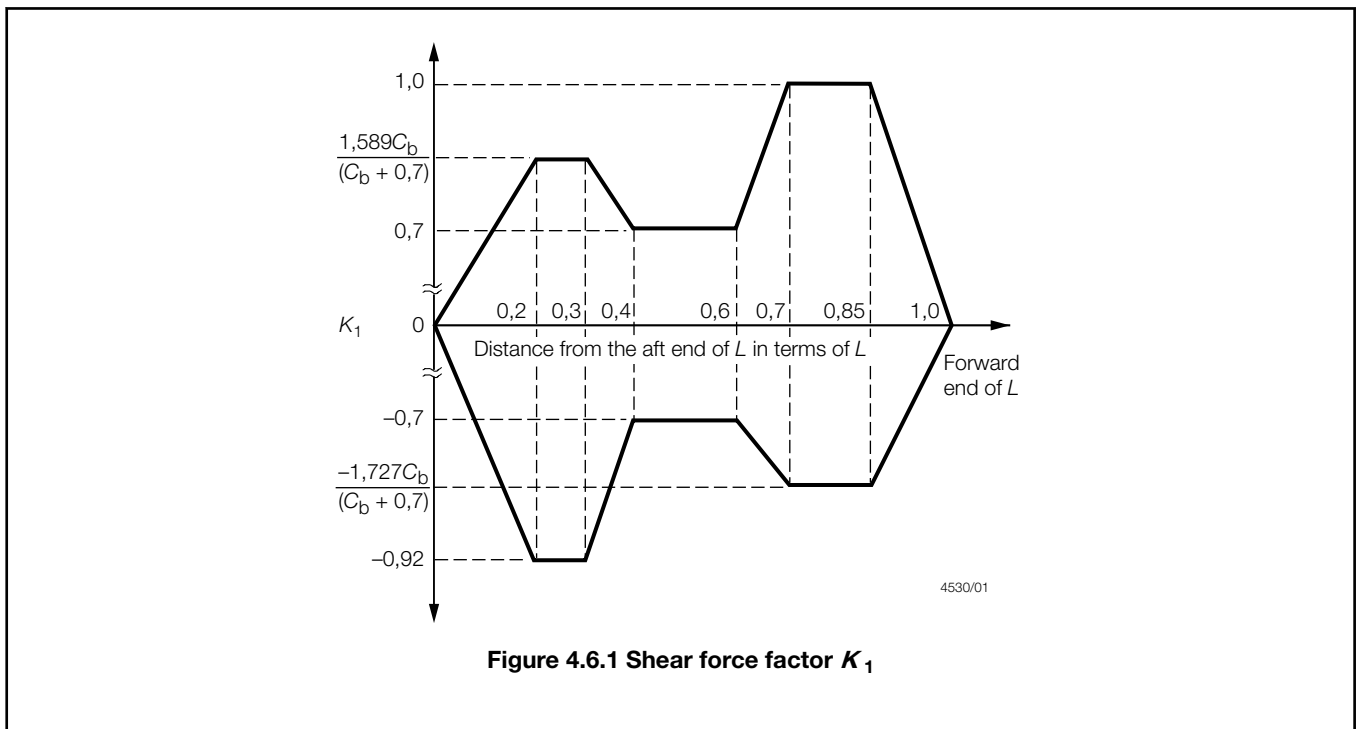

Figure 4.6.1 Shear force factor K_1

6.4 Design still water shear force

6.4.1 The design still water shear force, Q_s , at each transverse section along the hull is to be taken as the maximum positive and negative value found from the longitudinal strength calculations for each of the loading conditions given in *Pt 3, Ch 4, 5.3 Design still water bending moments 5.3.3* and is to satisfy the following relationship:

$$|q_s| \leq |\bar{q}_s|$$

6.4.2 Still water shear forces are to be calculated at each section along the ship length. For these calculations, downward loads are to be taken as positive values and are to be integrated in a forward direction from the aft end of L . The shear force is positive when the algebraic sum of all vertical forces aft of the section is positive.

6.4.3 For hull configuration Types A, D, G, H and I, as indicated in *Table 4.6.1 f_i factors* where loading conditions are featuring either:

- cargo loading with specified or alternative cargo holds (or cargo tanks) empty; or
- ballasting of cargo hold(s);

the actual shear forces obtained from the longitudinal strength calculations may be corrected for the effect of local forces at the transverse bulkheads. The calculation of these local forces is to be submitted for approval or, alternatively, the proportion of the double bottom load carried by the transverse bulkhead may be arrived at by using the following bulkhead factor F :

$$F = \frac{1}{1 + 1,5 \alpha^{1,65}}$$

where

l_F = span of floors measured to intersection of hopper side or ship's side, and inner bottom, in metres

S_H = length of hold measured between bulkhead stools, where fitted, at the level of the inner bottom on the centreline, in metres

$$\alpha = \frac{S_H}{l_F}$$

Table 4.6.1 f_i factors

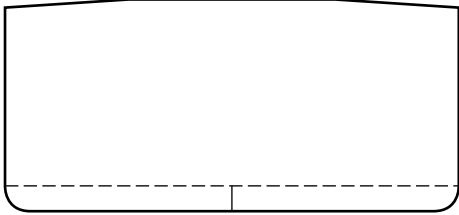
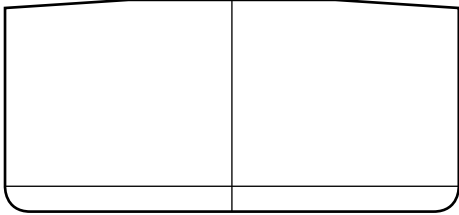
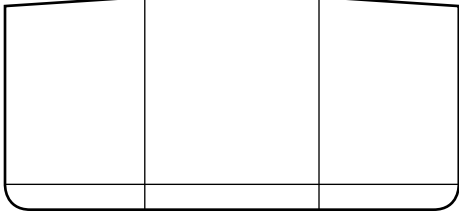
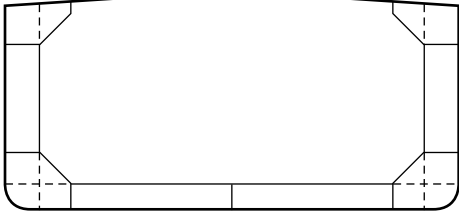
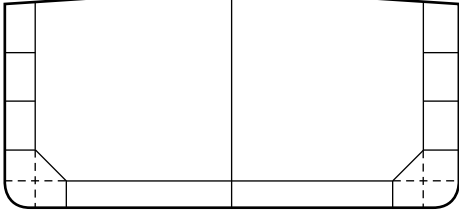
Hull configuration	f_i factors
<p style="text-align: center;">Type A</p>  <p style="text-align: right; font-size: small;">3688/00</p>	<p style="text-align: center;">Member 1</p> $f_1 = 0,5$
<p style="text-align: center;">Type B</p>  <p style="text-align: right; font-size: small;">3688/01</p>	<p style="text-align: center;">Member 1</p> $f_1 = 0,231 + 0,076 A_1/A_2$ <p style="text-align: center;">Member 2</p> $f_2 = 0,538 - 0,152 A_1/A_2$
<p style="text-align: center;">Type C</p>  <p style="text-align: right; font-size: small;">3688/02</p>	<p style="text-align: center;">Member 1</p> $f_1 = 0,135 + 0,088 A_1/A_2$ <p style="text-align: center;">Member 2</p> $f_2 = 0,365 - 0,088 A_1/A_2$
<p style="text-align: center;">Type D</p>  <p style="text-align: right; font-size: small;">3688/03</p>	<p style="text-align: center;">Member 1</p> $f_1 = 0,128 + 0,105 A_1/A_2$ <p style="text-align: center;">Member 2</p> $f_2 = 0,372 - 0,105 A_1/A_2$
<p style="text-align: center;">Type E</p>  <p style="text-align: right; font-size: small;">3688/04</p>	<p style="text-align: center;">Member 1</p> $f_1 = 0,055 + 0,097 A_1/A_2 + 0,020 A_2/A_3$ <p style="text-align: center;">Member 2</p> $f_2 = 0,193 - 0,059 A_1/A_2 + 0,058 A_2/A_3$ <p style="text-align: center;">Member 3</p> $f_3 = 0,504 - 0,076 A_1/A_2 - 0,156 A_2/A_3$

Longitudinal Strength

Part 3, Chapter 4

Section 6

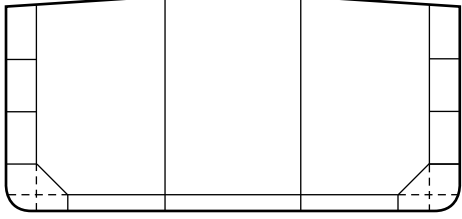
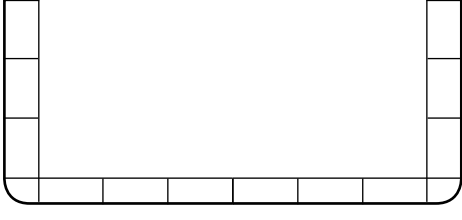
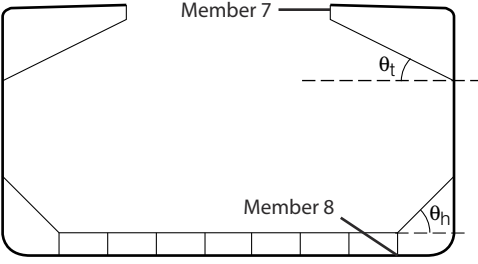
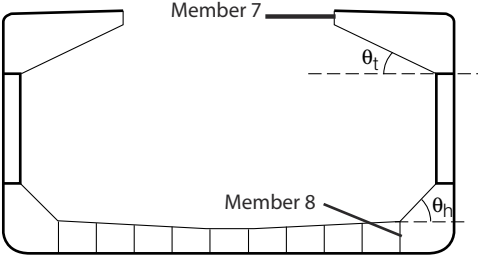
<p style="text-align: center;">Type F</p>  <p style="text-align: right;">3688/05</p>	<p style="text-align: center;">Member 1</p> $f_1 = 0,028 + 0,087 A_1/A_2 + 0,023 A_2/A_3$ <p style="text-align: center;">Member 2</p> $f_2 = 0,119 - 0,038 A_1/A_2 + 0,072 A_2/A_3$ <p style="text-align: center;">Member 3</p> $f_3 = 0,353 - 0,049 A_1/A_2 - 0,095 A_2/A_3$
<p style="text-align: center;">Type G</p>  <p style="text-align: right;">3688/09</p>	<p style="text-align: center;">Member 1</p> $f_1 = 0,139 + 0,099 A_1/A_2$ <p style="text-align: center;">Member 2</p> $f_2 = 0,361 - 0,099 A_1/A_2$
<p style="text-align: center;">Type H</p>  <p style="text-align: right;">3688/06</p>	<p style="text-align: center;">Member 1</p> $f_1 = 0,216 + 0,087 A_1/(A_7 + A_2 \sin \theta_t)$ <p style="text-align: center;">Member 2</p> $f_2 = 0,284 - 0,087 A_1/(A_7 + A_2 \sin \theta_t)$ <p style="text-align: center;">Member 3</p> $f_3 = 0,5$ <p style="text-align: center;">Member 5</p> $f_5 = 0,155 + 0,087 A_5/(A_8 + A_6 \sin \theta_n)$ <p style="text-align: center;">Member 6</p> $f_6 = 0,345 - 0,087 A_5/(A_8 + A_6 \sin \theta_n)$ $f_7 = f_2, f_8 = f_6$
<p style="text-align: center;">Type I</p>  <p style="text-align: right;">3688/07</p>	<p style="text-align: center;">Member 1</p> $f_1 = 0,216 + 0,087 A_1/(A_7 + A_2 \sin \theta_t)$ <p style="text-align: center;">Member 2</p> $f_2 = 0,284 - 0,087 A_1/(A_7 + A_2 \sin \theta_t)$ <p style="text-align: center;">Member 3</p> $f_3 = 0,143 + 0,104 A_3/A_4$ <p style="text-align: center;">Member 4</p> $f_4 = 0,357 - 0,104 A_3/A_4$ <p style="text-align: center;">Member 5</p> $f_5 = 0,155 + 0,087 A_5/(A_8 + A_6 \sin \theta_n)$ <p style="text-align: center;">Member 6</p> $f_6 = 0,345 - 0,087 A_5/(A_8 + A_6 \sin \theta_n)$ $f_7 = f_2, f_8 = f_6$

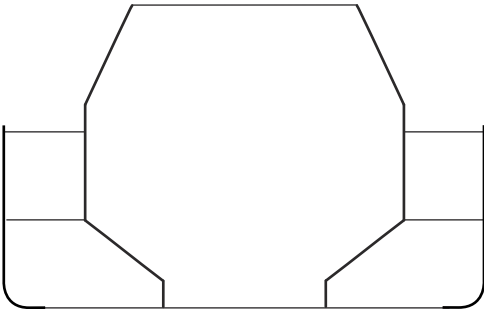
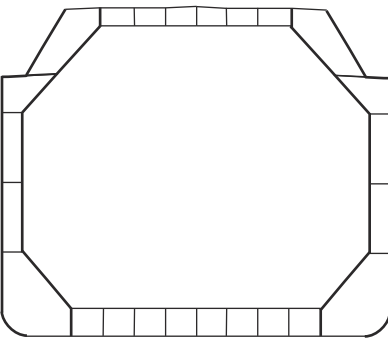
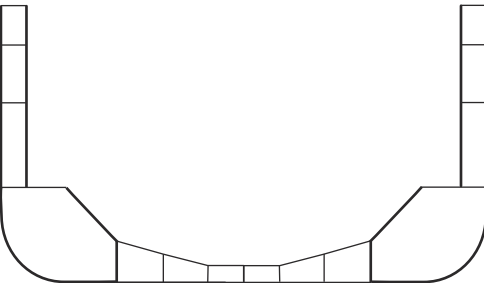
<p style="text-align: center;">Type J</p> 	<p style="text-align: center;">Member 1</p> $f_1 = 0,153 + 0,105A_1/A_2$ <p style="text-align: center;">Member 2</p> $f_2 = 0,347 - 0,105 A_1/A_2$
<p style="text-align: center;">Type K</p> 	<p style="text-align: center;">Member 1</p> $f_1 = 0,128 + 0,105A_1/A_2$ <p style="text-align: center;">Member 2</p> $f_2 = 0,372 - 0,105 A_1/A_2$
<p style="text-align: center;">Type L</p> 	<p style="text-align: center;">Member 1</p> $f_1 = 0,162 + 0,093A_1/A_2$ <p style="text-align: center;">Member 2</p> $f_2 = 0,338 - 0,093 A_1/A_2$

Symbols

i = structural member index for different hull configurations
for types A, B, C, D, E, F and G, i may take the value of 1, 2 or 3.

for $i = 1$, the side shell at the section is under consideration

for $i = 2$ and 3, the longitudinal bulkheads at the section are under consideration

for types H and I, i may take the value of 1, 2, 3, 4, 5, 6, 7 or 8

for $i = 1$, the part of side shell in way of topside tank is under consideration

for $i = 2$, the topside slope is under consideration

for $i = 3$, the part of side shell between topside tank and hopper tank is under consideration

for $i = 4$, the inner hull is under consideration

for $i = 5$, the part of side shell in way of hopper tank is under consideration

for $i = 6$, the hopper slope is under consideration

for $i = 7$, the vertical strake at topside tank is under consideration

for $i = 8$, the double bottom girder at hopper tank is under consideration

for types J, K and L, i may take the value of 1 or 2:

for $i = 1$, the side shell at the section is under consideration

for $i = 2$, the longitudinal bulkheads at the section are under consideration

$A_i =$ the area of structural member i at the section under consideration in cm^2

In the event of part of the structural member being non-vertical, A_i is to be calculated using the projected area in the vertical direction, see Figure 4.6.4 Calculation of A_i for non-vertical parts of structural members, except for members 2 and 6 for types H and I, where the inclined area is to be applied.

Note 1. For hull configurations not included above, f_i factors are to be specially considered.

Note 2. Where it is necessary to increase the thickness of the side shell or longitudinal bulkhead(s) to meet these requirements, the original thicknesses are to be used in the calculation of the cross-sectional areas of A_i .

6.4.4 If the hull shear forces in kN (tonne-f) at transverse bulkheads A and B are calculated to be Q_A and Q_B respectively (with appropriate algebraic signs), the excess load or buoyancy over hold AB is given by $Q_B - Q_A$ and the load transmitted to each bulkhead is:

(a) $0,5F(Q_B - Q_A)$ kN (tonne-f)

where F is the bulkhead factor as given in Pt 3, Ch 4, 6.4 Design still water shear force 6.4.3.

See Figure 4.6.2 Shear force correction.

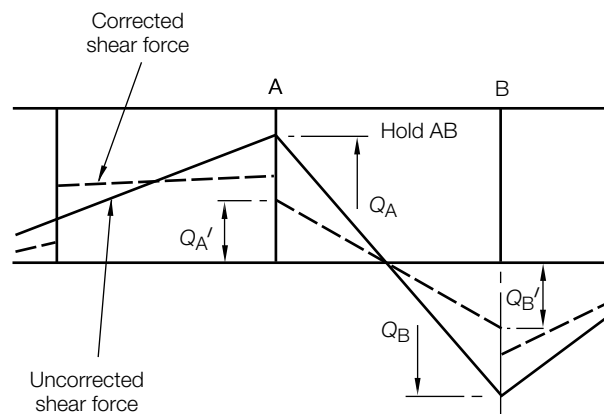

Figure 4.6.2 Shear force correction

6.4.5 The corrected shear forces, $Q_{A'}$ and $Q_{B'}$, at bulkheads A and B with respect to hold AB are then obtained from:

$$Q_{A'} = Q_A + 0,5F(Q_B - Q_A) \text{ kN (tonne-f)}$$

$$Q_{B'} = Q_B - 0,5F(Q_B - Q_A) \text{ kN (tonne-f)}$$

6.5 Permissible still water shear force

6.5.1 The permissible hull still water shear force is given by the minimum value obtained from:

$$|Q_s| = \tau \frac{I \delta_i}{100A_z[d1]} - |Q_w| \text{ kN(tonne - f)}$$

when

$$\delta_i = \frac{t_i}{f_i + m_i}$$

i = structural member index for the hull configuration under consideration, see *Table 4.6.1 f_i factors* .

t_i = the plate thickness of the structural member at the vertical level and section under consideration, in mm

f_i, m_i = factors determined from *Table 4.6.1 f_i factors* and *Table 4.6.2 m_i factors* respectively, for the hull configuration under consideration.

6.5.2 The permissible shear forces assigned for approved loading instruments will normally be based on *Pt 3, Ch 4, 6.5 Permissible still water shear force 6.5.1*. However, where use is made of an approved loading instrument incorporating a facility to calculate the transverse distribution of shear forces, separate permissible still water shear forces, Q_{si} may be assigned for the structural members indicated in *Table 4.6.1 f_i factors* for the hull configuration under consideration.

$$|Q_{si}| = (f_i + m_i) |Q_s| \text{ kN (tonne-f)}$$

6.5.3 Individual loading conditions in the ship's loading manual may be specially considered on a similar basis to that in *Pt 3, Ch 4, 6.5 Permissible still water shear force 6.5.2* with the factors being determined by direct calculation.

6.5.4 For hull configuration types B and E (see *Table 4.6.1 f_i factors*), where loading conditions are such that hull girder torsion may be induced, direct calculations may be required.

6.5.5 The calculation of shear forces immediately beyond the ends of the longitudinal bulkheads will be considered in relation to the arrangement of structure in these regions.

6.6 Permissible shear stress

6.6.1 The permissible combined shear stress (still water plus wave) is to be taken as:

$$\tau = \frac{110}{k_L} \text{ N/mm}^2 \left(\frac{11,2}{k_L} \text{ kgf/mm}^2 \right)$$

6.6.2 Where a plate is tapered, the permissible combined shear stress is not to be exceeded at any point in way of the taper, see *Figure 4.6.3 Tapered plates*.

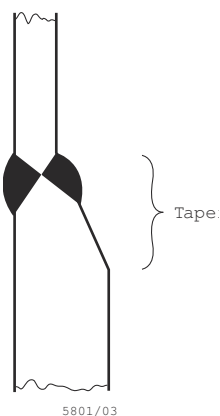

5801/03
Figure 4.6.3 Tapered plates

Table 4.6.2 m_i factors

Hull configuration, see Table 4.6.1	m_i factors
Type A	$m_1 = 0$
Type B	$m_1 = \frac{m_2}{2}, m_2 = (0,1+r)0,5$
Type C	$m_1 = m_2, m_2 = (0,1+r)\frac{b_2}{B}$
Type D	$m_1 = 0$
Type E	$m_1 = \frac{m_3}{4}, m_2 = \frac{m_3}{4}, m_3 = (0,1+r)0,5\left(1 - \frac{b_2}{B}\right)$
Type F	$m_1 = \frac{m_3}{2}, m_2 = \frac{m_3}{2}, m_3 = (0,1+r)\left(\frac{b_3 - 0,5b_2}{B}\right)$
Type G	$m_1 = 0$
Type H	$m_1 = 0$
Type I	$m_1 = 0$
Type J	$m_1 = 0$
Type K	$m_1 = 0$
Type L	$m_1 = 0$
Symbols	
<p>i = structural member index for different hull configurations, see Table 4.6.1 f_i factors</p> <p>b_i = the horizontal distance of the structural member i from the side shell, at the section under consideration, in metres</p> <p>r = 0,15 within $0,20L_T$ from the transverse bulkhead position for loading conditions where the cargo region between two consecutive bulkheads is unevenly loaded in the transverse direction</p> <p>= 0 within $0,20L_T$ from the transverse bulkhead position for loading conditions where the cargo region between two consecutive bulkheads is evenly loaded in the transverse direction</p> <p>= 0 elsewhere</p> <p>L_T = cargo hold length, in metres</p>	
<p>NOTE</p> <p>For hull configurations not included above, m_i factors are to be specially considered.</p>	

6.7 Design shear stress

6.7.1 The design shear stress for use in Pt 3, Ch 4, 7.4 Design stress is to be taken as:

$$\tau_A = 100Az \frac{|Q_s| + |Q_w|}{I \delta_i} \quad \text{N/mm}^2$$

$$\left(10,2Az \frac{|Q_s| + |Q_w|}{I \delta_i} \quad \text{kgf/mm}^2 \right)$$

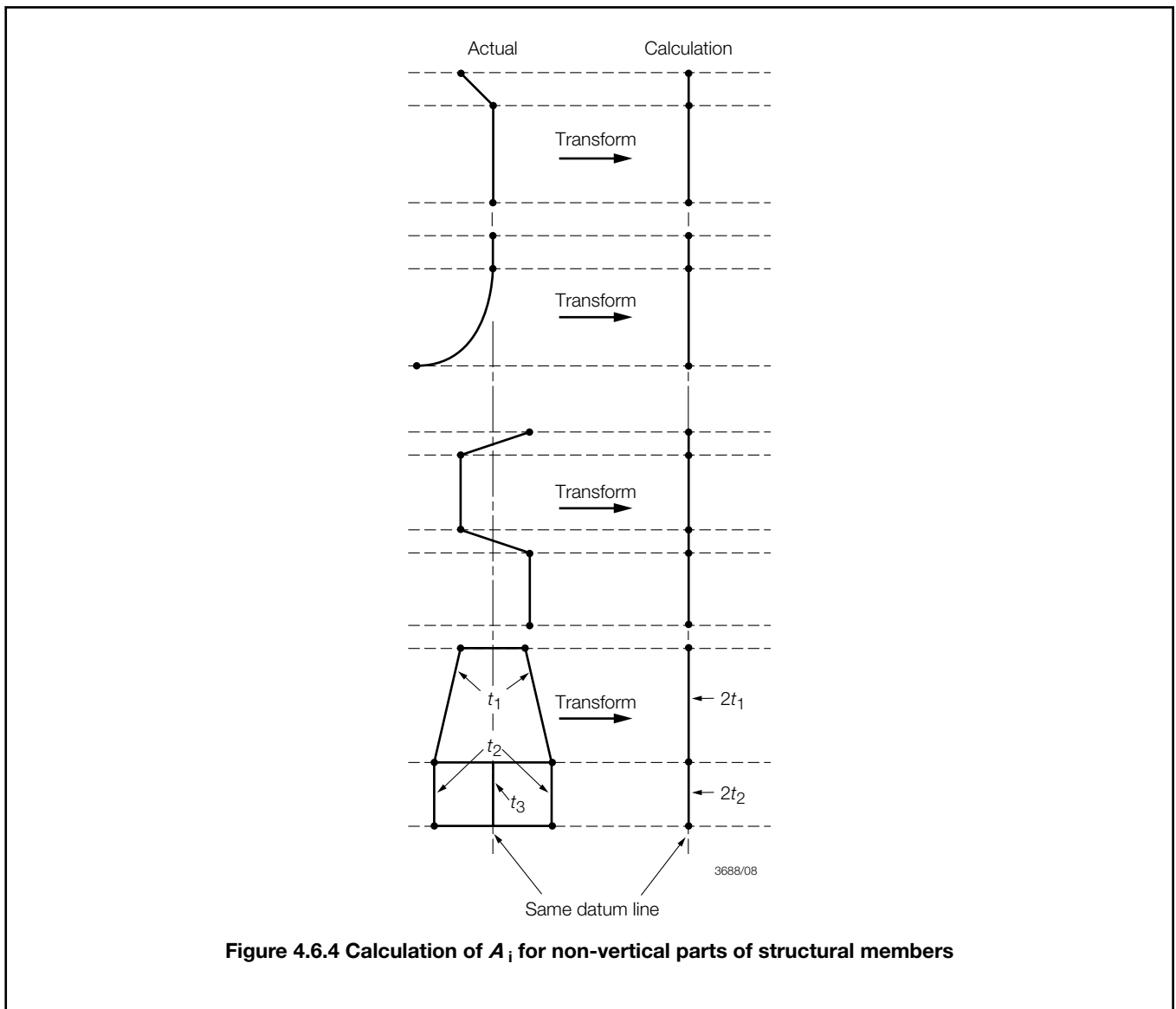

■ **Section 7**
Hull buckling strength

7.1 Application

7.1.1 These requirements apply to plate panels and longitudinals subjected to hull girder compression and shear stresses based on design values for still water and wave bending moments and shear forces.

7.1.2 The hull buckling strength requirements are applicable within $0,4L$ amidships to ships of 90 m or greater in length.

7.1.3 Hull buckling strength for ships less than 90 m in length will be specially considered.

7.1.4 Hull buckling strength outside $0,4L$ amidships of members contributing to the longitudinal strength and subjected to compressive and shear stresses is to be checked, in particular in regions where changes in the framing system or significant changes in the hull cross-section occur.

7.2 Symbols

7.2.1 The symbols used in this Section are defined as follows:

d_t = standard deduction for corrosion, see *Table 4.7.1 Standard deduction for corrosion, d_t*

s = spacing of secondary stiffeners, in mm. In the case of symmetrical corrugations, s is to be taken as b or c in *Figure 3.3.1 Corrugation dimensions* in Ch 3, whichever is the greater

t = as built thickness of plating, stiffener flange and web used in *Table 4.7.1 Standard deduction for corrosion, d_t* in calculating standard deduction d_t , in mm

t_p = as built thickness of plating less standard deduction d_t , in mm, (i.e. $t_p = t - d_t$)

E = modulus of elasticity, in N/mm² (kgf/mm²)

= 206000 N/mm²(21000 kgf/mm²) for steel

S = spacing of primary members, in metres

σ_o = specified minimum yield stress, in N/mm² (kgf/mm²)

σ_A = design longitudinal compressive stress in N/mm² (kgf/mm²)

σ_{CRB} = critical buckling stress in compression, in N/mm² (kgf/mm²) corrected for yielding effects

σ_E = elastic critical buckling stress in compression, in N/mm²(kgf/mm²)

τ_A = design shear stress in N/mm² (kgf/mm²)

τ_{CRB} = critical buckling stress in shear, N/mm² (kgf/mm²) corrected for yielding effects

τ_E = elastic critical buckling stress in shear, in N/mm² (kgf/mm²)

$$\tau_o = \frac{\sigma_o}{\sqrt{3}}$$

7.3 Elastic critical buckling stress

7.3.1 The elastic critical buckling stress of plating is to be determined from *Table 4.7.2 Elastic critical buckling strength of plating*.

7.3.2 The elastic critical buckling stress of longitudinals is to be determined from *Pt 3, Ch 4, 7.5 Scantling criteria 7.5.3*

7.4 Design stress

7.4.1 Design longitudinal compressive stress, σ_A , is to be determined in accordance with *Pt 3, Ch 4, 5 Hull bending strength* :

$$\text{minimum } \sigma_A = \frac{30}{k_L} \text{ N/mm}^2 \left(\frac{3,06}{k_L} \text{ kgf/mm}^2 \right)$$

for structural members above the neutral axis,

$$\sigma_A = \sigma_D \frac{z}{z_D}$$

for structural members below the neutral axis,

$$\sigma_A = \sigma_B \frac{z}{z_B}$$

σ_D based on sagging moment and σ_B based on hogging moment are determined in *Pt 3, Ch 4, 5.8 Hull moment of inertia 5.8.1*.

where

z = vertical distance from the hull transverse neutral axis to the position considered, excluding deck camber, in metres

where

Z_D, Z_B = vertical distances from the hull transverse neutral axis to the deck and keel respectively, in metres

For initial design purposes, the hull transverse neutral axis may be taken at a distance $\frac{D}{2}$ above keel, where D is the depth of the ship, in metres, as defined in *Pt 3, Ch 1, 6 Definitions*.

Table 4.7.1 Standard deduction for corrosion, d_t

Structure		d_t mm	d_t range mm min. - max.
(a) Compartments carrying dry bulk cargoes	–	0,05t	0,5 - 1
(b) One side exposure to water ballast and/or liquid cargo.	Vertical surfaces and surfaces sloped at an angle greater than 25° to the horizontal line.		
(c) One side exposure to water ballast and/or liquid cargo.	Horizontal surfaces and surfaces sloped at an angle less than 25° to the horizontal line.	0,10t	2 - 3
(d) Two side exposure to water ballast and/or liquid cargo.	Vertical surfaces and surfaces sloped at an angle greater than 25° to the horizontal line.		
(e) Two side exposure to water ballast and/or liquid cargo.	Horizontal surfaces and surfaces sloped at an angle less than 25° to the horizontal line.	0,15t	2 - 4
<p>Note 1. The standard deduction d_t is to be taken as appropriate and within the range given above.</p> <p>Note 2. For direct calculation purposes, standard deductions will be specially considered.</p>			

Table 4.7.2 Elastic critical buckling strength of plating

Mode	Elastic critical buckling stress, N/mm ² (kgf/mm ²)
(a) Compression of plating with longitudinal stiffeners (parallel to compressive stress), see Note	$\sigma_E = 3,6E \left(\frac{t_p}{s}\right)^2$
(b) Compression of plating with transverse stiffeners (perpendicular to compressive stress), see Note	$\sigma_E = 0,9_c \left[1 + \left(\frac{s}{1000S}\right)^2\right]^2 E \left(\frac{t_p}{s}\right)^2$ where $c = 1,3$ when plating stiffened by floors or deep girders $= 1,21$ when stiffeners are built up profiles or rolled angles $= 1,10$ when stiffeners are bulb plates $= 1,05$ when stiffeners are flat bars
(c) Shear, see Note	$\tau_E = 3,6 \left[1,335 + \left(\frac{s}{1000S}\right)^2\right] E \left(\frac{t_p}{s}\right)^2$
<p>Note Where the elastic critical buckling stress, as evaluated from (a), (b) or (c), exceeds 50 per cent of specified minimum yield stress of the material, the corrected critical buckling stresses in compression (σ_{CRB}) and shear (τ_{CRB}) are given by:</p> $\sigma_{CRB} = \sigma_E \quad \text{when } \sigma_E \leq \frac{\sigma_o}{2}$ $= \sigma_o \left(1 - \frac{\sigma_o}{4\sigma_E}\right) \quad \text{when } \sigma_E > \frac{\sigma_o}{2}$ <p style="text-align: right;">N/mm² (kgf/mm²)</p> $\tau_{CRB} = \tau_E \quad \text{when } \tau_E \leq \frac{\tau_o}{2}$ $= \tau_o \left(1 - \frac{\tau_o}{4\tau_E}\right) \quad \text{when } \tau_E > \frac{\tau_o}{2}$ <p style="text-align: right;">N/mm² (kgf/mm²)</p>	

7.4.2 Design shear stress, τ_A , is to be determined in accordance with Pt 3, Ch 4, 6 Hull shear strength .

For initial design purposes, τ_A may be taken as:

$$\tau_A = \frac{110}{k_L} \text{ N/mm}^2 \left(\frac{11,2}{k_L} \text{ kgf/mm}^2 \right)$$

7.5 Scantling criteria

7.5.1 The corrected critical buckling stress in compression, σ_{CRB} , of plate panels and longitudinals, as derived from Table 4.7.2 Elastic critical buckling strength of plating and Pt 3, Ch 4, 7.5 Scantling criteria 7.5.3, is to satisfy the following:

$$\sigma_{CRB} \geq \beta \sigma_A$$

where

$\beta = 1$ for plating and for web plating of longitudinals (local buckling)

$\beta = 1,1$ for longitudinals

7.5.2 The corrected critical buckling stress in shear, τ_{CRB} , of plate panels, as derived from *Table 4.7.2 Elastic critical buckling strength of plating*, is to satisfy the following:

$$\tau_{CRB} \geq \tau_A$$

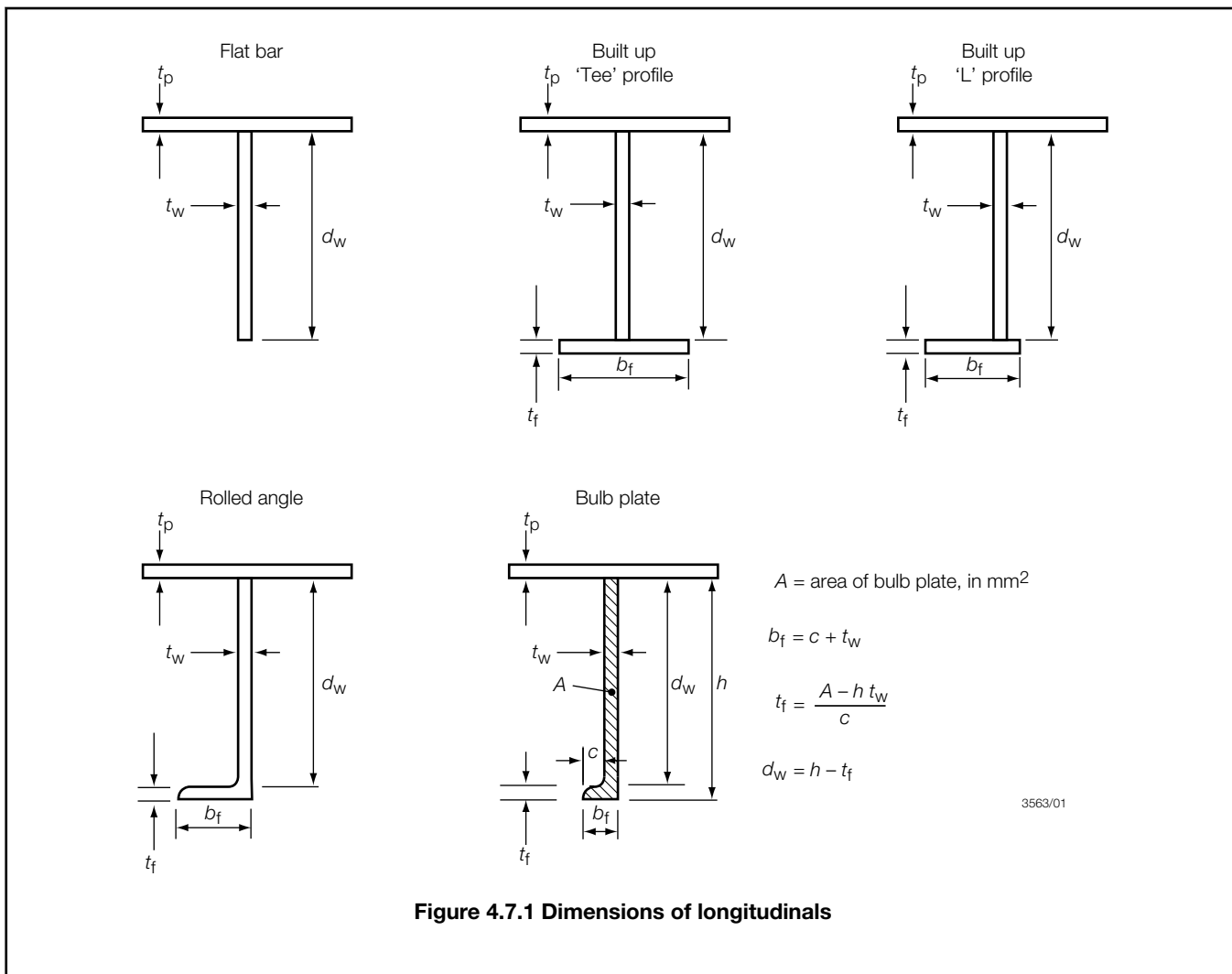

Figure 4.7.1 Dimensions of longitudinals

Table 4.7.3 Elastic critical buckling strength of longitudinals

Mode	Elastic critical buckling stress, N/mm ² (kgf/mm ²)
(a) Column buckling (perpendicular to plane of plating) without rotation of cross section, see Note 1	$\sigma_E = 0,001E \frac{I_a}{A_t S^2}$
(b) Torsional buckling, see Note 1	$\sigma_E = \frac{0,001EI_w}{I_p S^2} \left(m^2 + \frac{K}{m^2} \right) + 0,385E \frac{I_t}{I_p}$
(c) Web buckling, see Notes 1 and 3 (flat bars are excluded)	$\sigma_E = 3,8E \left(\frac{t_w}{d_w} \right)^2$
Symbols and Parameters	
$d_w = \text{web depth, in mm}$	

t_w = as built web thickness less standard deduction d_t as specified in Table 4.7.1 Standard deduction for corrosion, d_t , in mm, (i.e. $t_w = t - d_t$). For webs in which the thickness varies, a mean thickness is to be used

b_f = flange width, in mm

t_f = as built flange thickness less standard deduction d_t as specified in Table 4.7.1 Standard deduction for corrosion, d_t , in mm, (i.e. $t_f = t - d_t$). For bulb plates, the mean thickness of the bulb may be used, see Figure 4.7.1 Dimensions of longitudinals

A_t = cross-sectional area, in cm^2 , of longitudinal, including attached plating, taking account of standard deductions, see Note 4

I_a = moment of inertia, in cm^4 , of longitudinal, including attached plating, taking account of standard deductions, see Note 4

I_t = St.Venant's moment of inertia, in cm^4 , of longitudinal (without attached plating)

$$= \frac{d_w t_w^3}{3} 10^{-4} \text{ for flat bars}$$

$$= \frac{1}{3} \left[d_w t_w^3 + b_f t_f^3 \left(1 - 0,63 \frac{t_f}{b_f} \right) \right] 10^{-4} \text{ for built up profiles, rolled angles and bulb plates}$$

I_p = polar moment of inertia, in cm^4 , of profile about connection of stiffener to plating

$$= \frac{d_w^3 t_w}{3} 10^{-4} \text{ for flat bars}$$

$$= \left(\frac{d_w^3 t_w}{3} + d_w^2 b_f t_f \right) 10^{-4} \text{ for built up profiles, rolled angles and bulb plates}$$

I_w = sectorial moment of inertia, in cm^6 , of profile about connection of stiffener to plating

$$= \frac{d_w^3 t_w^3}{36} 10^{-6} \text{ for flat bars}$$

$$= \frac{t_f b_f^3 d_w^2}{12} 10^{-6} \text{ for 'Tee' profiles}$$

$$= \frac{b_f^3 d_w^2}{12(b_f + d_w)^2} \left[t_f (b_f^2 + 2b_f d_w + 4d_w^2) + 3t_w b_f d_w \right] 10^{-6} \text{ for 'L' profiles, rolled angles and bulb plates}$$

$$K = \frac{1,03CS^4}{EI_w} 10^4$$

m is determined as follows:

m	K range
1	$0 < K \leq 4$
2	$4 < K \leq 36$

3	36 < K ≤ 144
4	144 < K ≤ 400
5	400 < K ≤ 900
6	900 < K ≤ 1764
m	$(m - 1)^2 m^2 < K \leq m^2 (m + 1)^2$

C = spring stiffness exerted by supporting plate panel

$$= \frac{k_p E t_p^3}{3s \left(1 + \frac{1,33 k_p d_w t_p^3}{s t_w^3} \right)}$$

$k_p = 1 - \eta_p$, and is not to be taken less than zero. For built up profiles, rolled angles and bulb plates, k_p need not be taken less than 0,1

$n_p = \frac{\sigma_A}{\sigma_{EP}}$ where σ_{EP} = elastic critical buckling stress (σ_E) of supporting plate derived from *Table 4.7.2 Elastic critical buckling strength of plating*

All other symbols as defined in *Pt 3, Ch 4, 7.2 Symbols 7.2.1*.

Note 1. Where the elastic critical buckling stress, as evaluated from (a), (b) or (c), exceeds 50 per cent of specified minimum yield stress of the material, the corrected critical buckling stress in compression (σ_{CRB}) is given by: $\sigma_{CRB} = \sigma_o \left(1 - \frac{\sigma_o}{4 \sigma_E} \right) \text{N/mm}^2 (\text{kgf/mm}^2)$

Note 2. *Figure 4.7.1 Dimensions of longitudinals* shows the dimensions of longitudinals.

Note 3. For flanges on angles and T-sections of longitudinals, the following requirement is to be satisfied:

$$\frac{b_f}{t} \leq 15 \text{ for angles, } \frac{b_f}{t} \leq 30 \text{ for 'Tee' profiles,}$$

where

t = as built flange thicknesses, in mm

Note 4. The area of attached plating is to be calculated using actual spacing of secondary stiffeners.

■ **Section 8**
Loading guidance information

8.1 General

8.1.1 Sufficient information is to be supplied to the Master of every ship to enable him to arrange loading and ballasting in such a way as to avoid the creation of unacceptable stresses in the ship's structure.

8.1.2 This information is to be provided by means of a Loading Manual and in addition, where required, by means of an approved loading instrument.

8.2 Loading Manual

8.2.1 A Loading Manual is to be supplied to all ships where longitudinal strength calculations have been required, see *Pt 3, Ch 4, 2 General*. The Manual is to be submitted for approval in respect of strength aspects. Where both Loading Manual and loading instrument are supplied, the Loading Manual must nevertheless be approved from the strength aspect. In this case, the Manual is to be endorsed to the effect that any departures from these conditions in service are to be arranged on the basis of the loading instrument and the allowable local loadings shown in the Manual, see *Pt 3, Ch 4, 8.2 Loading Manual 8.2.4*.

8.2.2 The Manual is to be based on the final data of the ship and is to include well-defined lightweight distribution and buoyancy data.

8.2.3 Details of the loading conditions given in *Pt 3, Ch 4, 5.3 Design still water bending moments 5.3.3* are to be included in the Manual as applicable.

8.2.4 The Manual is also to contain the following:

- (a) Values of actual and permissible still water bending moments and shear forces and, where applicable, limitations due to torsional loads.
- (b) The allowable local loadings for the structure such as the hatch covers, decks and double bottoms. If the ship is not approved to carry load on the deck or hatch covers, this is to be clearly stated.
- (c) Details of cargo carriage constraints imposed by the use of an accepted coating in association with a system of corrosion control, see *Pt 3, Ch 2, 3.6 Application of coatings and alternative means of protection*.
- (d) A note saying:

'Scantlings approved for minimum draught forward of ...m with ballast tanks No... filled. In heavy weather conditions the forward draught should not be less than this value. If, in the opinion of the Master, sea conditions are likely to cause regular slamming, then other appropriate measures such as change in speed, heading or an increase in draught forward may also need to be taken.'

- (e) The maximum unladen weight, in tonnes, of grab that is considered suitable for the approved thickness of the hold inner bottom for bulk carriers and ore or oil carriers that are regularly discharged by grabs. This maximum unladen weight may differ for adjacent holds, see *Pt 3, Ch 9, 8.2 Inner bottom plating* and *Pt 4, Ch 7, 8.1 General*. This weight does not preclude the use of heavier grabs, but is intended as an indication to the Builders, Owners and operators of the increased risk of local damage and the possibility of accelerated diminution of the plating thickness if grabs heavier than this are used regularly to discharge cargo.

8.2.5 In addition to the requirements of *Pt 3, Ch 4, 8.2 Loading Manual 8.2.4*, the Manual is to contain the following information for bulk carriers (see *Pt 3, Ch 4, 3.2 General 3.2.2*), ore carriers and combination carriers of length, L , 150 m or above:

- (a) The cargo hold(s) or combination of cargo holds that may be empty at maximum draught. If no cargo hold is permitted to be empty at maximum draught, this is to be clearly stated in the Manual.
- (b) Maximum allowable and minimum required mass of cargo and double bottom ballast for each hold as a function of the draught at mid-hold position.
- (c) Maximum allowable and minimum required mass of cargo and double bottom ballast for any two adjacent holds as a function of the mean draught in way of these holds. The mean draught may be calculated by averaging the draught at the two mid-hold positions.
- (d) Maximum allowable inner bottom loading together with specification of the nature of the cargo, for cargoes other than bulk cargoes.
- (e) The maximum rate of ballast exchange, together with advice that a load plan is to be agreed with the terminal on the basis of achievable rates of exchange.

For bulk carriers for which it is required to undertake longitudinal strength calculations in the flooded condition, see *Pt 4, Ch 7, 3.1 General 3.1.2*, the Manual is also to contain envelope results and permissible limits of still water bending moments and shear forces for hold flooded conditions, see *Pt 4, Ch 7, 3.4 Flooded conditions*.

8.2.6 Where applicable, the Manual is also to contain the procedure for ballast exchange and sediment removal at sea.

8.2.7 Where alteration to structure, lightweight, cargo distribution or draught is proposed, revised information is to be submitted for approval.

8.3 Loading instrument

8.3.1 In addition to a Loading Manual, an approved type loading instrument is to be provided for all ships where L is greater than 65 m and which are approved for non-uniform distribution of loading. The following ships are exempt from this requirement:

- (a) Ships with very limited possibilities for variations in the distribution of cargo and ballast.
- (b) Ships with a regular or fixed trading pattern.
- (c) Ships exempt by individual Chapters in *Pt 4 Ship Structures (Ship Types)*.

8.3.2 The loading instrument is to be capable of calculating shear forces and bending moments, in any load or ballast condition at specified readout points and is to indicate the permissible values. On container ships and other ships with large deck openings, (see *Pt 3, Ch 4, 3.3 Exceptions 3.3.2*) cargo torque is also to be calculated.

8.3.3 For bulk carriers, ore carriers and combination carriers of length, L , 150 m or above, the loading instrument is to be additionally capable of verifying that the following are within permissible limits:

- (a) the mass of cargo and double bottom ballast in way of each hold as a function of the draught at the mid-hold position.
- (b) the mass of cargo and double bottom ballast for any two adjacent holds as a function of the mean draught in way of these holds. The mean draught may be calculated by averaging the draught at the two mid-hold positions.

For bulk carriers for which it is required to undertake longitudinal strength calculations in the flooded condition, see *Pt 4, Ch 7, 1.2 Application 1.2.2*, the loading instrument is also to be capable of verifying that the still water bending moments and shear forces in hold flooded conditions (see *Pt 4, Ch 7, 3.4 Flooded conditions*) are within permissible limits.

8.3.4 If the approved loading manual utilises bulkhead correction factors for shear force distribution, then the loading instrument must also have the capability to account for the bulkhead correction factors.

8.3.5 The instrument is to be certified in accordance with LR's document entitled *Approval of Longitudinal Strength and Stability Calculations Programs*.

8.3.6 The instrument readout points are usually selected at the position of the transverse bulkheads or other obvious boundaries. As many readout points as considered necessary by LR are to be included, e.g. between bulkheads.

8.3.7 A notice is to be displayed on the loading instrument stating:

- (a) 'Scantlings approved for minimum draught forward of ...m with ballast tanks No... filled. In heavy weather conditions, the forward draught should not be less than this value. If, in the opinion of the Master, sea conditions are likely to cause regular slamming, then other appropriate measures such as change in speed, heading or an increase in draught forward may also need to be taken.'

8.3.8 Where alteration to structure, lightweight or cargo distribution is proposed, the loading instrument is to be modified accordingly and details submitted for approval.

8.3.9 The operation of the loading instrument is to be verified by the Surveyors upon installation and at Annual and Periodical Surveys as required in *Pt 1, Ch 3 Periodical Survey Regulations*. An Operation Manual for the instrument is to be verified as being available on board.

8.3.10 Where an onboard computer system having a strength computation capability is provided as an Owner's option, it is recommended that the system be certified in accordance with LR's document entitled *Approval of Longitudinal Strength and Stability Calculations Programs*. For systems having a stability computation capability and installed on a new ship, see also *Pt 1, Ch 2, 1.1 General 1.1.11*. For systems having a stability computation capability and installed on an existing ship, it is recommended that the system be certified in accordance with LR's document entitled *Approval of Longitudinal Strength and Stability Calculation Programs*.

8.4 Onboard lashing program

8.4.1 An onboard lashing program to calculate forces acting on the container stowage arrangement may be provided, see *Pt 3, Ch 14 Cargo Securing Arrangements*. This may be an extension to the loading instrument covered under *Pt 3, Ch 4, 8.3 Loading instrument*. If the software to carry out lashing calculations is installed and maintained in accordance with the Rules, the ship will be eligible to be assigned the special features notation **BoxMax**, with one or more of the supplementary letters **V** and **W**.

8.4.2 To qualify for the notation **BoxMax** the following requirements must be satisfied:

- (a) The onboard lashing program is to be certified in accordance with LR's *Approval of Longitudinal Strength and Stability Calculation Programs*.
- (b) Where alteration to the container stowage arrangements is proposed, the onboard lashing program is to be modified accordingly and details submitted for approval.
- (c) The operation of the onboard lashing program is to be verified by the Surveyors upon installation and at Annual and Periodical Surveys as required in *Pt 1, Ch 3 Periodical Survey Regulations*. An Operation Manual for the onboard lashing program is to be verified as being available on board.

8.4.3 The onboard lashing program may also have the capability to take account of the various sea areas through which the container ship may trade. If the software to carry out lashing calculations is installed and maintained in accordance with the Rules

and includes the functionality to take account of voyage route using the methodology and factors supplied by LR, the ship will be eligible to be assigned the special features notation **BoxMax(V)**.

8.4.4 To qualify for the notation **BoxMax(V)** the following requirements must be satisfied:

- (a) The requirements for **BoxMax** must be satisfied.
- (b) The benefits of the notation may only be applied in sea areas for which LR has provided the factors for the ship. Elsewhere, the weather-dependent factors must be set to the values defined for unrestricted worldwide service, see *Pt 3, Ch 14, 1.5 Symbols and definitions*.
- (c) The voyage-specific aspects of the onboard lashing program are to be verified by the Surveyors upon installation and at Annual and Periodical Surveys as required in *Pt 1, Ch 3 Periodical Survey Regulations*. An Operations Manual for these aspects of the onboard lashing program is to be verified as being available on board.

8.4.5 The onboard lashing program may also have the capability to take account of the various seasons during which the container ship may trade. If the software to carry out lashing calculations is installed and maintained in accordance with the Rules and includes the functionality to take account of voyage route and season using the methodology and factors supplied by LR, the ship will be eligible to be assigned the special features notation **BoxMax(V,W)**.

8.4.6 To qualify for the notation **BoxMax(V,W)** the following requirements must be satisfied:

- (a) The requirements for **BoxMax(V)** must be satisfied.
- (b) The benefits of the notation may only be applied in sea areas and during seasons for which LR has provided the factors for the ship. If the required sea areas and seasons are not fully covered by the factors provided by LR, the weather-dependent factors must be set to the values defined for the notation **BoxMax(V)**, if available, or for unrestricted worldwide service, see *Pt 3, Ch 14, 1.5 Symbols and definitions*.
- (c) The voyage- and season-specific aspects of the onboard lashing program are to be verified by the Surveyors upon installation and at Annual and Periodical Surveys as required in *Pt 1, Ch 3 Periodical Survey Regulations*. An Operation Manual for these aspects of the onboard lashing program is to be verified as being available on board.

Section

- 1 **General**
- 2 **Deck structure**
- 3 **Shell envelope plating**
- 4 **Shell envelope framing**
- 5 **Single and double bottom structure**
- 6 **Fore peak structure**
- 7 **Forward deep tank structure**

■ Section 1 General

1.1 Application

1.1.1 This Chapter applies to all types of ship covered by *Pt 4 Ship Structures (Ship Types)* except where specifically stated otherwise.

1.1.2 The requirements given are those specific to fore ends and relate to structure situated in the region forward of $0,3L$ from the forward perpendicular.

1.1.3 Requirements for cargo space structure within this region not dealt with in this Chapter are to be as detailed in the relevant Chapter of *Pt 4 Ship Structures (Ship Types)* for the particular ship type.

1.1.4 The requirements in this Chapter are not applicable to Double Hull Oil Tankers or Bulk Carriers with a **CSR** notation. See *Pt 1, Ch 2, 2.3 Class notations (hull)*.

1.2 Structural configuration

1.2.1 The Rules provide for both longitudinal and transverse framing systems.

1.2.2 In the case of container ships and open type ships, additional requirements may apply as detailed in *Pt 4, Ch 8 Container Ships*.

1.2.3 In the case of fast cargo ships, the additional requirements given in *Pt 4, Ch 1, 3 Longitudinal strength* are to be complied with where applicable.

1.2.4 The requirements regarding minimum bow height given in *Pt 3, Ch 3, 6 Minimum bow heights, reserve buoyancy and extent of forecastle* are to be complied with where applicable.

1.3 Structural continuity

1.3.1 Suitable scarfing arrangements are to be made to ensure continuity of strength and the avoidance of abrupt structural changes.

1.3.2 Where longitudinal framing terminates and is replaced by a transverse system, adequate arrangements are to be made to avoid an abrupt changeover. Where a forecastle is fitted extending aft of $0,15L$ from the F.P., longitudinal framing at the upper deck and topsides is generally to be continued forward of the end bulkhead of this superstructure. In bulk carriers and oil tankers (see *Pt 3, Ch 5, 1.1 Application 1.1.4*) the longitudinal framing at the upper deck is to be maintained over the cargo space region and continued over the fore peak region.

1.3.3 In container or similar ships having continuous side tanks or double skin construction in way of the cargo spaces, the longitudinal bulkheads are to be continued as far forward as is practicable and are to be suitably tapered at their ends. Where, due to the ship's form, such bulkheads are stepped, suitable scarfing is to be arranged.

1.3.4 In bulk carriers (see Pt 3, Ch 5, 1.1 Application 1.1.4) the topside tank and double bottom hopper tank structures are to be maintained over the cargo space region, and suitable taper brackets are to be arranged in line with the end of these tank structures in the fore peak region. In addition, in way of the cargo space forward bulkhead, a girder or intercostal bulb plate stiffeners (fitted between and connected to the bulkhead vertical stiffeners), are to be arranged on the forward side in line with the sloped bulkheads of the topside and hopper tanks clear of the taper brackets.

1.4 Symbols and definitions

1.4.1 The following symbols and definitions are applicable to this Chapter unless otherwise stated:

L, B, D, T, C = as defined in Pt 3, Ch 1, 6.1 Principal particulars
 b and V

k_L, k = higher tensile steel factor, see Pt 3, Ch 2, 1.2 Steel

l = overall length of stiffening member, in metres, see Pt 3, Ch 3, 3.3 Determination of span point

l_e = effective length of stiffening member, in metres, see Pt 3, Ch 3, 3.3 Determination of span point

s = spacing of secondary stiffeners, in mm

t = thickness of plating, in mm

I = inertia of stiffening member, in cm^4 , see Pt 3, Ch 3, 3.2 Geometric properties of section

S = spacing, or mean spacing, of primary members, in metres

Z = section modulus of stiffening member, in cm^3 , see Pt 3, Ch 3, 3.2 Geometric properties of section

ρ = relative density (specific gravity) of liquid carried in a tank and is to be taken not less than 1,025.

1.4.2 For the purpose of this Chapter the forward perpendicular, F.P., is defined as the forward limit of the Rule length L .

1.5 Strengthening of bottom forward

1.5.1 The bottom forward of a sea-going ship is to be additionally strengthened, except where the ship is so designed that a minimum draught forward, T_{FB} , of $0,045L$ can be achieved for any ballast or part loaded condition. This draught is to be indicated on the shell expansion plan, the plan showing the internal strengthening, the Loading Manual and loading instrument, where fitted, see Pt 3, Ch 4, 8 Loading guidance information.

1.5.2 The requirements for the additional strengthening apply to ships where L is greater than 65 m. Where a ship is classed for service in protected waters or extended protected waters, compliance with the requirements of this Section may be modified or waived altogether.

1.5.3 The additional strengthening is to extend forward of $0,3L$ from the F.P. over the flat of bottom and adjacent plating with attached stiffeners up to a height of $0,002L$ above the base line or 300 mm whichever is the lesser.

1.5.4 The scantling requirements outside the areas defined in Pt 3, Ch 5, 1.5 Strengthening of bottom forward 1.5.3 are to be suitably tapered to maintain adequate continuity of strength in both longitudinal and transverse directions.

1.5.5 The requirements for the additional strengthening within the region defined in Pt 3, Ch 5, 1.5 Strengthening of bottom forward 1.5.3 are given in Table 5.1.1 Additional strengthening of bottom forward, or may be obtained by direct calculation. Where T_{FB} is less than $0,01L$, the additional strengthening is to be specially considered.

1.5.6 Bottom longitudinals are to pass through and be supported by the webs of primary members. The vertical web stiffeners are to be connected to the bottom longitudinals. The cross-sectional area of the connections is to comply with the requirements given in Table 5.1.1 Additional strengthening of bottom forward.

1.5.7 The scantlings required by this Section must in no case be less than those required by the remaining Sections in Pt 3, Ch 5 Fore End Structure.

1.5.8 For minimum draught forward, T_{FB} between $0,01L$ and $0,045L$, the equivalent slamming pressure expressed as a head of water, h_s , is to be obtained from Figure 5.1.1 Pressure heads, where h_{max} is calculated from the following expressions:

$$65 < L \leq 169 \text{ m, } h_{\max} = 10\sqrt{L} F \text{ m}$$

$$169 < L \leq 180 \text{ m, } h_{\max} = 130F \text{ m}$$

$$L > 180 \text{ m, } h_{\max} = 130 F e^{-0,0125(L-180)^{0,705}} \text{ m}$$

where

$$F = 5,95 - 10,5 \left(\frac{T_{FB}}{L} \right)^{0,2}$$

= and

e = base of natural logarithms, 2,7183

- (a) The application of the maximum pressure for forward of 0,3L from the F.P. is as indicated in Figure 5.1.1 Pressure heads. For C_b between 0,70 and 0,80 its position may be obtained by linear interpolation.
- (b) Where the bottom plating forms the boundary of a double bottom tank, deep tank or double skin tank which is full in all ballast conditions, then for such conditions the head, h_s , may be reduced by 1,25 times the head, in metres, of ballast water to top of tank.
- (c) For bulk carriers (see Pt 3, Ch 5, 1.1 Application 1.1.4) the reduction to the head, h_s , is not to exceed the head, in metres, of ballast water to the top of the hopper tank or 1,25 times the depth, in metres, of the double bottom tank, whichever is the greater.
- (d) For ballast and part loaded conditions where the draught forward is less than 0,045L and the reduction to the head, h_s , has been applied, the ballast tanks are to be filled and a note added to the loading booklet to this effect, see Pt 3, Ch 4, 8.2 Loading Manual 8.2.4.

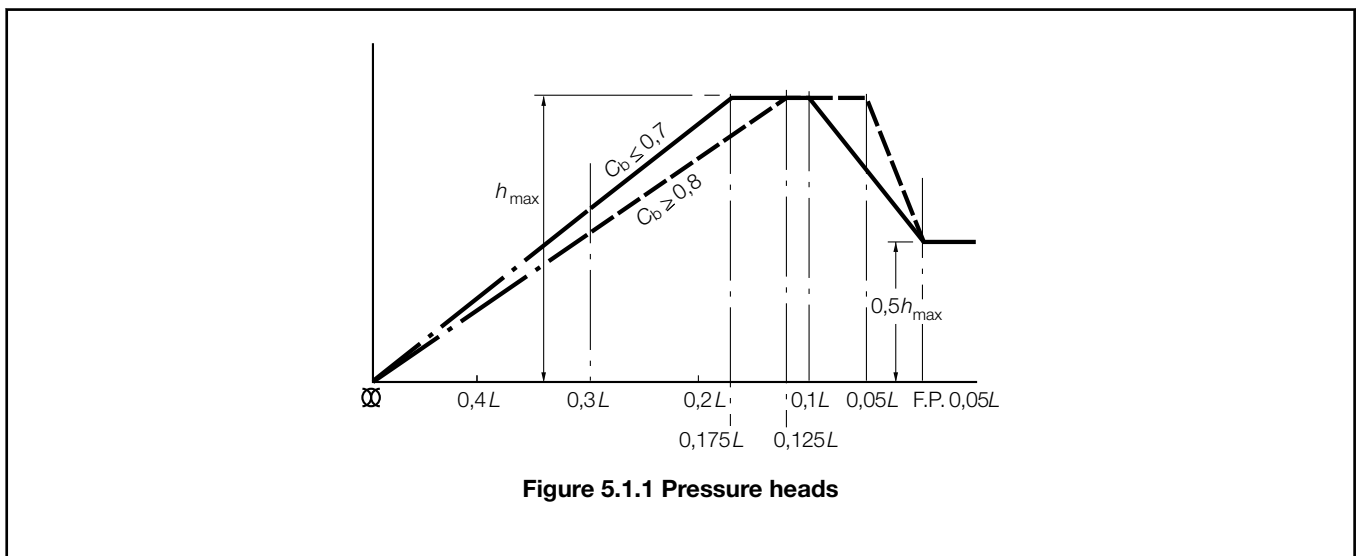

Figure 5.1.1 Pressure heads

1.6 Strengthening against bow flare slamming

1.6.1 The requirements of this Section apply to all ships except those defined in Pt 4, Ch 2 Ferries, Roll On-Roll Off Ships and Passenger Ships and Pt 4, Ch 8 Container Ships.

1.6.2 The side structure in the area forward of 0,075L from the F.P. and above the summer load waterline is to be strengthened against bow flare impact pressure. The strengthening is to extend vertically to the uppermost deck level, including the forecastle deck, if fitted, but need not exceed the level of $T + 1,65H_b$ above the base line, where H_b is the minimum bow height, in metres, as derived in Pt 3, Ch 1, 6.1 Principal particulars 6.1.11.

1.6.3 The flare angle, α , is the angle between the vertical axis and the tangent of the outer shell measured normal to the shell in a vertical plane, at the point under consideration. The entry angle, β , is the angle between the longitudinal axis and the waterplane tangent measured on the outer shell, at the point under consideration. The flare angle may normally be derived in accordance with Figure 5.1.2 Flare angle determination.

Table 5.1.1 Additional strengthening of bottom forward

Item	Requirements		
(1) Longitudinally framed bottom shell plating (including keel), see Notes 1 and 2	$t = 0,003sf\sqrt{h_s k}$		
(2) Bottom longitudinals - other than flat bars	$\frac{d_w}{t_w} \leq 55\sqrt{k}$ $\frac{d_w t_w}{100} \geq 0,00033 kh_s sc \left(S - \frac{s}{2000} \right) \text{cm}^2$ $Z \geq 6,8 \times 10^{-6} h_s sk \left[(17,5l_s)^2 - (0,01s)^2 + d_w c \left(S - \frac{s}{2000} \right) \right] \text{cm}^3$ $\frac{(A_1 \bar{\tau} + \alpha)}{p} \times 10^{-1} \geq 1$ $A_w \geq 0,84A_1$		
(3) Bottom longitudinals - flat bars	Will be specially considered		
	<table style="width:100%; border:none;"> <tr> <td style="width:50%; border:none; text-align:center;">Transverse framing</td> <td style="width:50%; border:none; text-align:center;">Longitudinal framing</td> </tr> </table>	Transverse framing	Longitudinal framing
Transverse framing	Longitudinal framing		

<p>(4) Primary structure in way of single bottoms</p>	<p>(a) Centre girder: Scantlings as required by item (1) in <i>Table 5.5.1 Single bottom construction forward</i>, except that in determining Z in way of a deep tank forward of $0,2L$ from the F.P. the value of h_5 is to be increased by the following percentages: where $T_{FB} \leq 0,03L_2$, 30 per cent where $T_{FB} \geq 0,04L_2$, 0 per cent The increase in h_5 for intermediate values of T_{FB} to be obtained by interpolation</p> <p>(b) Floors: Scantlings as required by item (2) in <i>Table 5.5.1 Single bottom construction forward</i>, except that in way of dry cargo spaces the minimum face area is to be increased by the following percentages: where $T_{FB} \leq 0,03L_2$, 50 per cent where $T_{FB} \geq 0,04L_2$, 0 per cent The increase of minimum face area for intermediate values of T_{FB} is to be obtained by interpolation</p> <p>(c) Side girders: Arrangement and scantlings as required by <i>Pt 3, Ch 5, 5.2 Single bottoms – Transverse framing 5.2.2</i> and <i>Pt 3, Ch 5, 5.2 Single bottoms – Transverse framing 5.2.3</i>, with the addition of intermediate half-height girders or equivalent fore and aft stiffening</p>	<p>(a) Ships having one or more longitudinal bulkheads: (i) Centre girder Scantlings as required by item (4) in <i>Table 5.5.1 Single bottom construction forward</i> and (iii) (ii) Bottom transverses Maximum spacing As for midships region Scantlings as required by <i>Pt 4, Ch 9, 9 Primary members supporting longitudinal framing</i> or <i>Pt 4, Ch 10, 2 Primary members supporting longitudinal framing</i> (iii) For horizontally stiffened longitudinal bulkheads and girders the depth to thickness ratio of the panel attached to the bottom shell plate is not to exceed $55\sqrt{k}$ (iv) Where $T_{FB} < 0,025L_2$ the scantlings and arrangements will receive individual consideration (b) Other ship arrangements will receive individual consideration</p>
<p>(5) Primary structure in way of double bottoms, see Note 3</p>	<p>(a) Plate floors: Maximum spacing, every frame Scantlings as required by <i>Pt 4, Ch 1, 8 Double bottom structure</i></p> <p>(b) Centre and side girders: Maximum spacing, $0,003S_F$ m</p> <p>(c) Intermediate half-height girders to be arranged midway between side girders: Scantlings as required for non watertight side girders by <i>Pt 4, Ch 1, 8 Double bottom structure</i></p>	<p>(a) Plate floors: Maximum spacing: $0,002s_F$ m for $T_{FB} < 0,04L_2$ $0,003s_F$ m for $T_{FB} \geq 0,04L_2$ but not to exceed that required by item (2) in <i>Table 5.5.2 Double bottom construction forward</i> Scantlings as required by <i>Pt 4, Ch 1, 8 Double bottom structure</i></p> <p>(b) Centre and side girders: Maximum spacing: $0,003s_L$ m for $T_{FB} < 0,04L_2$ $0,004s_L$ m for $T_{FB} > 0,04L_2$</p>

		but not to exceed that required by item (4) in Table 5.5.2 Scantlings as required by Pt 4, Ch 1, 8 Double bottom structure
(6) Primary structure in way of double bottoms supported by longitudinal bulkheads	–	The scantlings and arrangements will receive individual consideration on the basis of direct calculations using, if necessary, a suitably defined two-dimensional grillage model, see Pt 3, Ch 1, 3 Equivalents
Symbols		
<p><i>L, T, s, k</i> as defined in Pt 3, Ch 5, 1.4 Symbols and definitions 1.4.1</p> <p>$c = 1,0$ for $S \leq 2,5$ m $= (0,87 + 0,16S) c_1$ for $S > 2,5$ m</p> <p>$c_1 = 1,0$ for $S \leq 1,0$ m $= (1,14 - 0,14S)$ for $1,0 \text{ m} < S \leq 4,0$ m $= \frac{2,32}{S}$ for $S > 4,0$ m</p> <p>d_w = web depth, in mm, which for bulb flats may be taken as 0,9 times the section height</p> <p>$f = \left(1,1 - \frac{s}{2500S}\right)$ = but not greater than 1,0</p> <p>h_s = equivalent slamming pressure, in metres obtained from Pt 3, Ch 5, 1.5 Strengthening of bottom forward 1.5.8</p> <p>$l_s = l_e$, in metres, as defined in Pt 3, Ch 5, 1.4 Symbols and definitions 1.4.1 where in way of a double bottom = S, in metres, where in way of a single bottom</p> <p>S = spacing of primary members, in metres</p> <p>$p = 9,81 h_s s c_1 \left[S - \frac{s}{2000}\right] \times 10^{-3}$ kN $= \left(h_s s c_1 \left[S - \frac{s}{2000}\right] \times 10^{-3}\right)$ tonne $\cdot f$</p> <p>s_F = spacing of transverse frames, in mm, for longitudinally framed side and bottom construction s_F may be taken as s_L</p> <p>s_L = spacing of bottom longitudinals, in mm</p> <p>t_w = web thickness, in mm</p> <p>A_f = cross-sectional area of primary member web stiffener, in cm^2</p> <p>A_{fc} = effective area of primary member web stiffener in way of butted end connection to the longitudinal, in cm^2</p>		

A_L = area of weld of lapped connection, in cm^2 , calculated as total length of weld, in cm \times throat thickness, in cm

A_w = area of weld of lug and web connection to the longitudinal, in cm^2 , calculated as total length of weld in cm \times throat thickness, in cm

A_1 = effective total cross-sectional area of the lug and web connection to the longitudinal, in cm^2

L_2 = L but need not be taken greater than 215 m

T_{FB} = draught, in metres, at the F.P., as defined in Pt 3, Ch 5, 1.5 Strengthening of bottom forward 1.5.1

α = $A_1 \bar{\sigma}$ for the web stiffeners

= $A_{fc} \bar{\sigma}$ for a butted connection to the longitudinals

= $A_L \bar{\tau}$ for a lapped connection

$\bar{\sigma}$ = permissible direct stress, in N/mm^2 (kgf/mm^2), given in Table 5.1.2 Permissible stresses

$\bar{\tau}$ = permissible shear stress, in N/mm^2 (kgf/mm^2), given in Table 5.1.2 Permissible stresses

Note 1. If intermediate stiffening is fitted the thickness of the bottom shell plating may be 80 per cent of that required by (1) but is to be not less than the normal taper thickness.

Note 2. For transverse framing the bottom shell plating is to be specially considered.

Note 3. Particular care is to be taken to limit the size and number of openings in way of the ends of floors or girders or to fit suitable reinforcement where such openings are essential.

Note 4. The welding requirements of Pt 3, Ch 10 Welding and Structural Details, and in cargo oil tanks of tankers, the requirements of Pt 4, Ch 9, 10.14 Arrangements at intersections of continuous secondary and primary members or Pt 4, Ch 10, 7.14 Arrangements at intersections of continuous secondary and primary members, are also to be complied with.

1.6.4 The equivalent bow flare slamming head, h_S , is to be taken as:

$$h_S = 0,8(0,2 + 1,5 \tan \alpha) \left(0,51V \sin \beta \cos \alpha + \frac{\pi}{\sqrt{L}} \delta \right)^2 \text{ m}$$

where

V = as defined in Pt 3, Ch 5, 1.4 Symbols and definitions 1.4.1

α = flare angle, in degrees, at the point under consideration

β = entry angle, in degrees, at the point under consideration

δ = $\left(\frac{\pi}{30} L e^{-0,0033L} - 0,5d \right)$ and is not to be taken less than zero

e = base of natural logarithms 2,7183

d = vertical distance, in metres, between the waterline at draught T and the point under consideration.

1.6.5 The thickness of the side shell is to be not less than:

$$t = 3,2s_C \sqrt{kh_S} C_R \times 10^{-2} \text{ mm}$$

where

s_C = spacing of secondary stiffeners, in mm, measured along a chord between parallel adjacent members or equivalent supports, as shown in *Figure 5.1.3 Chord spacing and mean chord spacing for secondary members*

h_S = bow flare slamming head, in metres, as defined in *Pt 3, Ch 5, 1.6 Strengthening against bow flare slamming 1.6.3*

C_R = panel ratio factor

$$= \left(\frac{l}{s_C} \right)^{0,41} \text{ but is not to be taken less than } 0,06 \text{ or greater than } 0,1$$

l = overall panel length, in metres, measured along a chord between the primary members.

1.6.6 The scantlings of secondary stiffeners are not to be less than:

(a) Section modulus of secondary stiffeners

$$Z = 3,6 s_{CM} k h_s l_e^2 \times 10^{-3} \text{ cm}^3$$

(b) Web area of secondary stiffeners

$$A = 3,7 s_{CM} k h_s (l_e - s_{CM}/2000) \times 10^{-4} \text{ cm}^2$$

where

s_{CM} = mean spacing of secondary stiffeners, in mm, measured along a chord between parallel adjacent members or equivalent supports, as shown in *Figure 5.1.3 Chord spacing and mean chord spacing for secondary members*

h_S = bow flare slamming head, in metres, as defined in *Pt 3, Ch 5, 1.6 Strengthening against bow flare slamming 1.6.3*

= Other symbols are as defined in *Pt 3, Ch 5, 1.4 Symbols and definitions 1.4.1*.

Table 5.1.2 Permissible stresses

Item		Direct stress, $\bar{\sigma}$ in N/mm ² (kgf/mm ²) see Note	Shear stress, $\bar{\tau}$ in N/mm ² (kgf/mm ²)
Primary member web stiffener on area A_f	(a) Flat bars see Note	$\frac{10,3}{k} \left[33 - \frac{d}{t\sqrt{k}} \right]$ $\left(\frac{1,05}{k} \left[33 - \frac{d}{t\sqrt{k}} \right] \right)$	— —
	(b) Bulb plates see Note	$\frac{8,6}{k} \left[40 - \frac{d}{\left(\frac{100A_f}{d} - \frac{t}{6} \right) \sqrt{k}} \right]$	—
		$\left(\frac{0,88}{k} \left[40 - \frac{d}{\left(\frac{100A_f}{d} - \frac{t}{6} \right) \sqrt{k}} \right] \right)$	—
	(c) Inverted angles	$\frac{220}{k} \left(\frac{22,4}{k} \right)$	—

Primary member web stiffener on area A_{fc}		$\frac{245}{k} \left(\frac{25}{k} \right)$	—
Primary member web stiffener lapped to secondary member on area A_L		—	$\frac{167}{k} \left(\frac{17}{k} \right)$
Lug or web connection on area A_1	Single	—	$\frac{124}{k} \left(\frac{12,6}{k} \right)$
	Double	—	$\frac{141}{k} \left(\frac{14,4}{k} \right)$
Symbols			
A_f, A_L, A_1 as defined in <i>Table 5.1.1 Additional strengthening of bottom forward</i> d = stiffener depth, in mm k = as defined in <i>Pt 3, Ch 5, 1.4 Symbols and definitions 1.4.1</i> t = stiffener web thickness, in mm			
Note $\bar{\sigma}$ to be taken not greater than $\frac{220}{k} \left(\frac{22,4}{k} \right)$			

1.6.7 The scantlings of primary members are not to be less than:

(a) Section modulus of primary members

$$Z = 2S_{CM} k h_s l_e^2 \text{ cm}^3$$

(b) Web area of primary members

$$A = 0,2S_{CM} k h_s l_e \text{ cm}^2$$

where

S_{CM} = mean spacing of primary members, in metres, measured along a chord between parallel adjacent members or equivalent supports, as shown in *Figure 5.1.4 Mean chord spacing for primary members*

h_s = bow flare slamming head, in metres, as defined in *Pt 3, Ch 5, 1.6 Strengthening against bow flare slamming 1.6.4*

= Other symbols are as defined in *Pt 3, Ch 5, 1.4 Symbols and definitions 1.4.1*.

1.6.8 For primary members with cut-outs for the passage of secondary stiffeners, and which may have web stiffeners connected to the secondary stiffener, buckling checks are to be carried out to ensure that the primary member web plating and web stiffener will not buckle under the design load. The buckling procedure to be followed is given in *Table 5.1.3 Buckling procedure for primary member web plating and web stiffener*. Where the web stiffener is fitted with a bracket, the buckling capability of the web stiffener in way of the cut-out is to take account of the bracket. Where no web stiffener is fitted, the buckling capability of the primary member web plating is to be checked for the total load transmitted to the connection.

1.6.9 The structural scantlings required in areas strengthened against bow flare slamming are to be tapered from 0,075L aft of fore perpendicular to meet the normal requirements at 0,15L aft of the fore perpendicular.

1.6.10 Where the stiffener web is not perpendicular to the plating, tripping brackets may need to be fitted in order to obtain adequate lateral stability.

1.6.11 For stiffeners and primary structure, where the angle between the stiffener web and the plating is less than 70°, the effective section modulus and shear area are to take account of the non-perpendicularity.

1.6.12 The side structure scantlings required by this Section must in no case be taken less than those required by the remaining Sections of *Pt 3, Ch 5 Fore End Structure*.

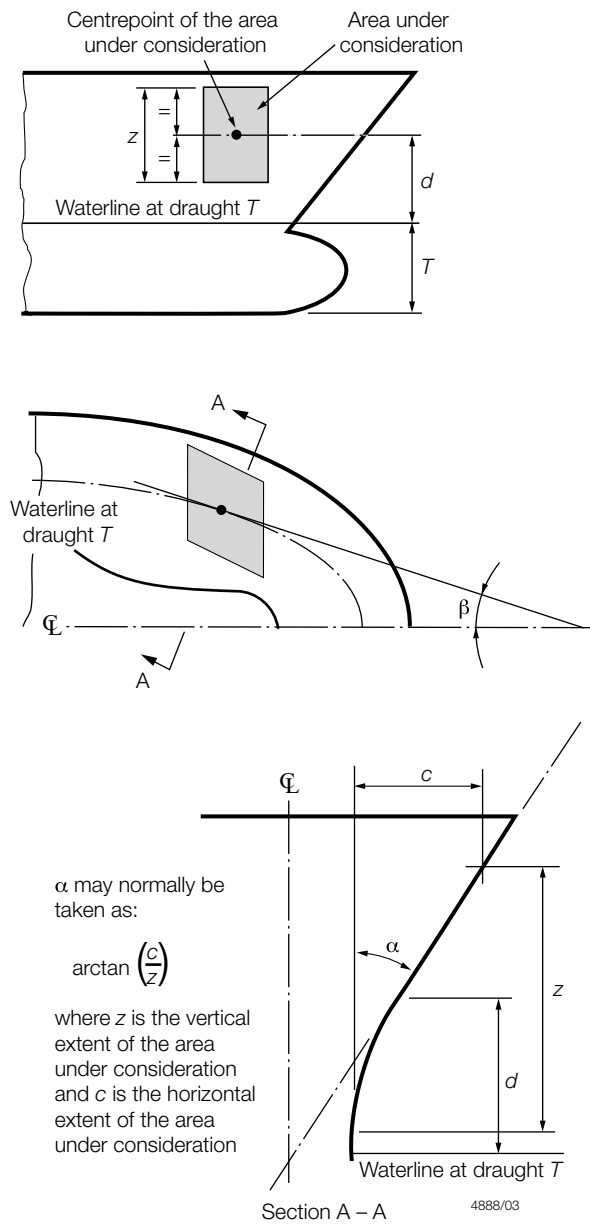
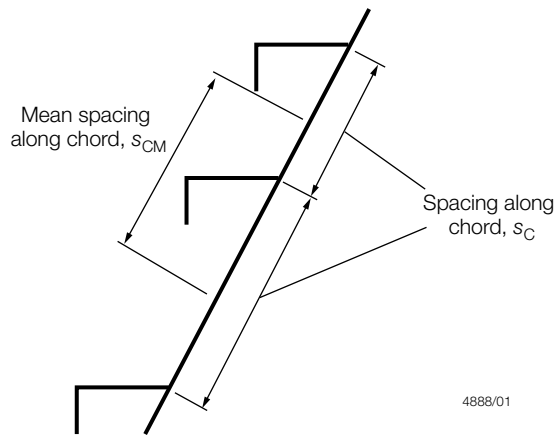
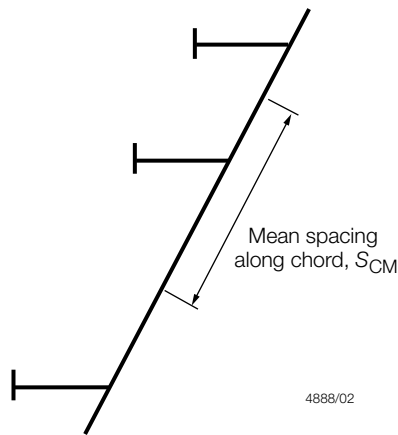

Figure 5.1.2 Flare angle determination



4888/01

Figure 5.1.3 Chord spacing and mean chord spacing for secondary members



4888/02

Figure 5.1.4 Mean chord spacing for primary members

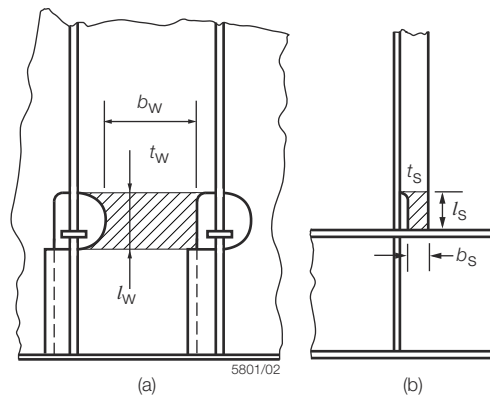

5801/02

Figure 5.1.5 Dimensions of critical areas of (a) primary member web plating and (b) primary web stiffener

Table 5.1.3 Buckling procedure for primary member web plating and web stiffener

Steps	Members	
	Primary member web plating	Primary member web stiffener
Determination of the design compressive stress, σ_A , N/mm ² (kgf/mm ²)	$\sigma_A = \frac{1000P_W}{A_W}$	$\sigma_A = \frac{1000P_S}{A_S}$
Determination of the elastic critical buckling stress, σ_E , in compression, N/mm ² (kgf/mm ²)	$\sigma_E = \frac{9,87EI_W}{l_W^2 A_W}$	$\sigma_E = \frac{9,87EI_S}{l_S^2 A_S}$
Determination of the corrected critical buckling stress, σ_{CR} , in compression, N/mm ² (kgf/mm ²)	$\sigma_{CR} = \sigma_0 \left(1 - \frac{\sigma_0}{4\sigma_E} \right) \text{ where } \sigma_E > \frac{\sigma_0}{2}$ $\sigma_{CR} = \sigma_E \text{ where } \sigma_E \leq \frac{\sigma_0}{2}$	
Requirement	$\sigma_{CR} \geq \sigma_A$	
Symbols		
<p>b_W, b_S, l_W, and l_S are dimensions, in mm, as shown in Figure 5.1.5 Dimensions of critical areas of (a) primary member web plating and (b) primary web stiffener</p> <p>h_S = equivalent bow flare slamming head, in metres, as defined in Pt 3, Ch 5, 1.6 Strengthening against bow flare slamming 1.6.3</p> <p>s_{CM} = mean spacing of secondary stiffeners, in mm, as defined in Pt 3, Ch 5, 1.6 Strengthening against bow flare slamming 1.6.5</p> <p>t_W = thickness of primary member web plating, in mm</p> <p>t_S = thickness of primary member web stiffener, in mm</p> <p>$A_W = b_W t_W \text{ mm}^2$</p> <p>$A_S = b_S t_S \text{ mm}^2$</p> <p>$E$ = modulus of elasticity, in N/mm² (kgf/mm²) = 206000 N/mm² (21000 kgf/mm²) for steel</p> <p>$I_W = \frac{b_W t_W^3}{12} \text{ mm}^4$</p> <p>$I_S = \frac{b_S t_S^3}{12} \text{ mm}^4$</p> <p>$P$ = total load transmitted to the connection = 10,06 $S_{CM} s_{CM} h_S \times 10^{-3} \text{ kN}$</p>		

$$(P = 1,025 S_{CM} s_{CM} h_S \times 10^{-3} \text{ tonne-f})$$

P_W = load transmitted through the primary member web stiffener, in kN (tonne-f)
= $P - P_S$, or by direct calculations

P_S = load transmitted through the primary member web stiffener, in kN (tonne-f), to be determined from Pt 3, Ch 10, 5.2 Arrangements at intersections of continuous secondary and primary members 5.2.7, or by direct calculations

S_{CM} = mean spacing of primary members, in metres, as defined in Pt 3, Ch 5, 1.6 Strengthening against bow flare slamming 1.6.6

σ_0 specified minimum yield stress, in N/mm²(kgf/mm²)

■ Section 2 Deck structure

2.1 General

2.1.1 Where the upper deck is longitudinally framed outside the line of openings in the midship region, this system of framing is to be carried as far forward as possible. In the case of oil tankers (see Pt 3, Ch 5, 1.1 Application 1.1.4) longitudinal framing is to extend to at least the forward end of the cargo tank section.

2.2 Deck plating

2.2.1 The thickness of strength/weather deck plating is to comply with the requirements of Table 5.2.1 Strength/weather deck plating forward (excluding forecastle deck).

2.2.2 The thickness of lower deck plating is to comply with the requirements of Table 5.2.2 Lower deck plating forward.

2.2.3 The taper thickness of the strength deck stringer plate is to be increased by 20 per cent at the end of a forecastle or bridge where the end bulkhead is situated aft of 0,25L from the F.P. No increase is required where the end bulkhead lies forward of 0,2L from the F.P. The increase at intermediate positions is to be determined by interpolation.

2.2.4 The deck plating thickness and supporting structure are to be suitably reinforced in way of the anchor windlass and other deck machinery, and in way of cranes, masts or derrick posts.

2.2.5 Where long, wide hatchways are arranged at lower decks, it may be necessary to increase the deck plating thickness to ensure effective support for side framing.

2.3 Deck stiffening

2.3.1 The scantlings of strength/weather deck longitudinals are to comply with the requirements of Table 5.2.3 Strength/weather deck longitudinals forward.

2.3.2 The scantlings of cargo and accommodation deck longitudinals are to comply with the requirements given in Table 1.4.4 Cargo and accommodation deck longitudinals in Pt 4, Ch 1 General Cargo Ships.

2.3.3 End connections of longitudinals to bulkheads are to provide adequate fixity, lateral support and, so far as practicable, direct continuity of longitudinal strength.

2.3.4 The scantlings of weather deck beams are to comply with the requirements of Table 5.2.4 Weather deck beams forward.

2.3.5 The scantlings of lower deck beams are to comply with the requirements of Table 1.4.5 Strength/weather, cargo and accommodation deck beams in Pt 4, Ch 1 General Cargo Ships.

Table 5.2.1 Strength/weather deck plating forward (excluding forecastle deck)

Symbols	Location	Thickness, in mm
<p>L, D, T, s, S, k, ρ as defined in Pt 3, Ch 5, 1.4 Symbols and definitions 1.4.1</p> <p>$C = \left(\frac{D + 2,3 - T}{\text{height of deck above load waterline at F.P.}} \right)$ but is to be taken not greater than 1,0 nor less than 0,9</p>	(1) Forward of 0,075L from the F.P.	$t = (6,5 + 0,02L)C \sqrt{\frac{ks_1}{s_b}}$
<p>$s_1 = s$, but to be taken not less than s_b</p> <p>s_b = standard frame spacing as follows:</p> <p>(a) forward of 0,05L from the F.P.:</p> <p>$s_b = \left(470 + \frac{L}{0,6} \right)$ mm or 600 mm,</p>	(2) Between 0,075L and 0,2L from the F.P.	<p>The greater of the following:</p> <p>(a) $t = (5,5 + 0,02L)C \sqrt{\frac{ks_1}{s_b}}$</p> <p>(b) the taper thickness (see Notes 1, 2 and 3)</p> <p>(c) For oil tankers, the thickness is also to be in accordance with Pt 4, Ch 9, 4.3 Deck plating 4.3.3</p>
whichever is the lesser	(3) Aft of 0,2L from the F.P.	The taper thickness (see Notes 1, 2 and 3) or as (2) (c) whichever is the greater
(b) between 0,05L and 0,2L from the F.P.:	(4) Inside forecastle extending aft of 0,15L from the F.P.	As for a lower deck (see Note 4)
<p>$s_b = \left(470 + \frac{L}{0,6} \right)$ mm or 700 mm, whichever is the lesser</p> <p>$f = 1,1 - \frac{s}{2500S}$ but to taken not greater than 1,0</p> <p>h_4 = tank head, in metres, as defined in Ch 3,5</p>	(5) In way of crown of a tank	<p>$t = 0,004sf \sqrt{\frac{\rho kh_4}{1,025}} + 3,5$</p> <p>or as in (1) to (4) as applicable, whichever is the greater but not less than:</p> <p>7,5 mm where $L \geq 90$ m, or</p> <p>6,5 mm where $L < 90$ m</p>
<p>Note 1. The taper thickness is to be determined from Table 3.2.1 Taper requirements for hull envelope.</p> <p>Note 2. For taper area requirements, see Table 3.2.1 Taper requirements for hull envelope.</p> <p>Note 3. For thickness of upper deck plating in way of the cargo and fore peak tanks of oil tankers or ore carriers, see also Pt 4, Ch 9 Double Hull Oil Tankers, Pt 4, Ch 10 Single Hull Oil Tankers or Pt 4, Ch 11 Ore Carriers, as applicable.</p> <p>Note 4. The exposed deck taper thickness is to extend into a forecastle or bridge for at least one-third of the breadth of the ship from the superstructure end bulkhead.</p> <p>Note 5. The taper requirements from Table 3.2.1 Taper requirements for hull envelope in Pt 3, Ch 3 Structural Design do not apply to container ships or open ship types, see Pt 3, Ch 4, 2.3 Open type ships, where the requirements of Pt 4, Ch 8, 3.2 Longitudinal strength are applicable, nor to fast cargo ships where the requirements of Pt 4, Ch 1, 3 Longitudinal strength are applicable. See also Pt 3, Ch 4, 5 Hull bending strength for hull section modulus requirement away from the midship area.</p>		

Table 5.2.2 Lower deck plating forward

Symbols	Location	Thickness, in mm
<p>L, s, S, k, ρ as defined in Pt 3, Ch 5, 1.4 Symbols and definitions 1.4.1</p> <p>b = breadth of increased plating, in mm</p> <p>$f = 1,1 - \frac{s}{2500S}$ but is to be taken not greater than 1,0</p> <p>h_4 = tank head, in metres, as defined in Pt 3, Ch 3, 5 Design loading</p> <p>$K_2 = 2,5$ mm at bottom tank, or = 3,5 mm at crown of tank</p> <p>$s_1 = s$, but is to be taken not less than $\left(470 + \frac{L_1}{0,6}\right)$ mm</p> <p>A_f = girder face area, in cm²</p> <p>$L_1 = L$, but need not be taken greater than 190 m</p> <p>Note 1. Where the deck loading exceeds 43,2 kN/m² (4,4 tonne-f/m²), the thickness of plating will be specially considered. This is equivalent to a 'tween deck height of 6,1 m in association with the standard stowage rate 1,39 m³/tonne.</p> <p>Note 2. For minimum thickness of deck plating in oil tankers, see Pt 4, Ch 9, 10.2 Compartment minimum thickness.</p>	(1) Forward of 0,075L from the F.P.	$t = 0,01s_1\sqrt{k}$ but not less than 6,5 mm
	(2) Aft of 0,075L from the F.P., inside line of openings	$t = 0,01s_1\sqrt{k}$ but not less than 6,5 mm
	(3) Aft of 0,075L from the F.P., outside line of openings	As determined by a taper line from the midship thickness to the end thickness given by (1)
	(4) In way of crown or bottom of tank	$t = 0,004fs\sqrt{\frac{\rho kh_4}{1,025}} + K_2$ or as in (1), (2) or (3) as applicable, whichever is the greater but not less than: = 7,5 mm where $L \geq 90$ m, = 6,5 mm where $L < 90$ m
	(5) Plating forming the upper flange of underdeck girders	Clear of cargo hatches $t = \sqrt{\frac{A_f}{1,8k}}$ In way of hatch side girders $t = 1,1\sqrt{\frac{A_f}{1,8k}}$
	Minimum breadth	$b = 760$ mm

2.3.6 End connections of beams are to be in accordance with the requirements of Pt 3, Ch 10, 3 Secondary member end connections.

2.4 Deck supporting structure

2.4.1 The arrangements and scantlings of supporting structure are generally to be in accordance with the requirements given in Pt 4, Ch 1, 4 Deck structure using the heads given in Pt 3, Ch 3, 5 Design loading for the particular region concerned, except as required by Pt 3, Ch 5, 2.4 Deck supporting structure 2.4.2 to Pt 3, Ch 5, 2.4 Deck supporting structure 2.4.4.

2.4.2 The spacings of girders and transverses are generally not to exceed the values given in Table 5.2.5 Spacing of girders and transverses under strength/weather decks forward.

2.4.3 Primary structure in the topside tanks of bulk carriers is to comply with the requirements of Pt 4, Ch 7, 7 Topside tank structure.

2.4.4 Primary structure in the cargo tanks of oil tankers and ore carriers is to be determined from Pt 4, Ch 9 Double Hull Oil Tankers, Pt 4, Ch 10 Single Hull Oil Tankers or Pt 4, Ch 11 Ore Carriers, as applicable.

2.5 Deck openings

2.5.1 In dry cargo ships the requirements for deck openings given in Pt 4, Ch 1, 4 Deck structure are generally applicable throughout the forward region, except that forward of 0,25L from the F.P.:

- (a) The radii or dimensions of the corners of main cargo hatchway openings on the strength deck are to be in accordance with the requirements of Pt 4, Ch 1, 4.5 Deck openings. The thickness of the insert plates, where required, is not to be less than 20 per cent greater than the adjacent deck thickness outside the line of openings, with a minimum increase of 3 mm.
- (b) Insert plates will be required at lower decks in way of any rapid change in hull form to compensate for loss of deck cross-sectional area. Otherwise, insert plates will not normally be required.
- (c) Compensation and edge reinforcement for openings outside the line of main hatchways will be considered, bearing in mind their position, the deck arrangements and the type of ship concerned.

2.5.2 For deck openings in way of the cargo tanks in oil tankers and ore carriers, see also Pt 4, Ch 9 Double Hull Oil Tankers, Pt 4, Ch 10 Single Hull Oil Tankers or Pt 4, Ch 11 Ore Carriers, as applicable. For main cargo hatchway openings on bulk carriers and container ships, see also Pt 4, Ch 7 Bulk Carriers and Pt 4, Ch 8 Container Ships, as applicable.

Table 5.2.3 Strength/weather deck longitudinals forward

Location	Modulus, cm ³	Inertia, cm ⁴
(1) Forward of 0,075L from the F.P.	The greater of the following: (a) $Z = sk(635h_1 + 0,0078(l_e L_1)^2) \times 10^{-4}$ (b) $Z = 0,0127skh_1 l_e^2$	—
(2) At 0,075L from the F.P., for end modulus for taper	The greater of the following: (a) $Z_e = sk(485h_0 + 0,0062(l_{e1} L_1)^2) \times 10^{-4}$ (b) $Z_e = 0,009skh_0 l_{e1}^2$	—
(3) Aft of 0,075L from the F.P., outside line of openings	As given by (4) or as determined from Table 3.2.1 Taper requirements for hull envelope whichever is the greater, see Note 1	—
(4) At 0,075L and between 0,075L and 0,12L from the F.P.	The greater of the following: (a) $Z = sk(570h_1 + 0,0072(l_e L_1)^2) \times 10^{-4}$ (b) $Z = 0,0127skh_1 l_e^2$	—
(5) Aft of 0,12L from the F.P., inside line of main cargo hatchways openings	The greater of the following: (a) $Z = sk(400h_1 + 0,005(l_e L_1)^2) \times 10^{-4}$ (b) $Z = 0,007skh_1 l_e^2$	—
(6) In way of the crown of a tank	As (1) to (5), as applicable, or $Z = \frac{0,0113 \rho skh_4 l_e^2}{b}$ whichever is the greater	$I = \frac{2,3}{k} l_e Z$
Symbols		
L, s, k _L , k _p as defined in Pt 3, Ch 5, 1.4 Symbols and definitions 1.4.1		
<p>b = 1,4 for rolled or built sections = 1,6 for flat bars</p> <p>d_w = web depth of longitudinal, in mm</p>		

$$h_o = 1,2 \text{ m for dry cargo ships}$$

$$= \frac{L_1}{56} \text{ m for oil tankers (see Pt 3, Ch 5, 1.1 Application 1.1.4)}$$

$$h_1 = \text{weather head, in metres, as defined in Pt 3, Ch 3, 5 Design loading for dry cargo ships}$$

$$= \frac{L_1}{70} \text{ m for oil tankers (see Pt 3, Ch 5, 1.1 Application 1.1.4)}$$

$$h_4 = \text{tank head, in metres, as defined in Pt 3, Ch 3, 5 Design loading}$$

l_e as defined in Pt 3, Ch 5, 1.4 Symbols and definitions 1.4.1, but is to be taken not less than 1,5 m

l_{e1} is to be taken as the maximum span in metres in the midship cargo tank region for oil tankers (see Pt 3, Ch 5, 1.1 Application 1.1.4) and equal to l_e for dry cargo ships

$$L_1 = L \text{ but need not be taken greater than 190 m}$$

Note 1. For area taper requirements, see also Table 3.2.1 Taper requirements for hull envelope.

Note 2. Where weather decks are intended to carry deck cargo and the loading is in excess of 8,5 kN/m² (0,865 tonne-f/m²), the scantlings of longitudinals may be required to be increased to comply with the requirements for location (1) in Table 1.4.4 Cargo and accommodation deck longitudinals using the equivalent design head, for specified cargo loadings, for weather decks given in Table 3.5.1 Design heads and permissible cargo loadings.

Note 3. For the scantlings of deck longitudinals forward in way of the cargo tanks of oil tankers (see Pt 3, Ch 5, 1.1 Application 1.1.4) or ore carriers, see also Pt 4, Ch 9 Double Hull Oil Tankers, Pt 4, Ch 10 Single Hull Oil Tankers or Pt 4, Ch 11 Ore Carriers, as applicable.

Note 4. The thickness of flat bar longitudinals situated outside the line of openings is to be not less than the following: (a) $t = \frac{d_w}{18\sqrt{k_L}} \text{ mm}$

where longitudinal continuous through bulkhead (b) $t = \frac{d_w}{15\sqrt{k_L}} \text{ mm}$ where longitudinal cut at bulkhead

Note 5. The web depth of longitudinal, d_w , is to be not less than 60 mm.

Note 6. The taper requirements from Table 3.2.1 Taper requirements for hull envelope in Pt 3, Ch 3 Structural Design do not apply to container ships or open ship types, see Pt 3, Ch 4, 2.3 Open type ships, where the requirements of Pt 4, Ch 8, 3.2 Longitudinal strength are applicable, nor to fast cargo ships where the requirements of Pt 4, Ch 1, 3 Longitudinal strength are applicable. See also Pt 3, Ch 4, 5 Hull bending strength for hull section modulus requirement away from the midship area.

Table 5.2.4 Weather deck beams forward

Location	Modulus, cm ³	Inertia, cm ⁴
(1) Forward of 0,075L from the F.P.	The lesser of the following: (a) $Z = k(800K_1TD + 5,4B_1sh_1l_e^2) \times 10^{-4}$ (b) $Z = 10,8B_1skh_1l_e^2 \times 10^{-4}$	—
(2) Between 0,075L and 0,12L from the F.P.	The lesser of the following: (a) $Z = k(800K_1TD + K_3B_1sh_1l_e^2) \times 10^{-4}$ (b) $Z = 2K_3B_1skh_1l_e^2 \times 10^{-4}$	—
(3) Aft of 0,12L from the F.P.	As required for location (1) of <i>Table 1.4.5 Strength/weather, cargo and accommodation deck beams</i>	—
(4) In way of the crown of a tank	As (1), (2) or (3), as applicable, or $Z = \frac{0,0113 \rho kh_4l_e^2}{b}$ whichever is the greater	$I = \frac{2,3}{k} l_e Z$
Symbols		
<i>B, D, T, s, ρ, k</i> as defined in <i>Pt 3, Ch 5, 1.4 Symbols and definitions 1.4.1</i>	<i>K₁</i> = a factor dependent on the number of decks (including a bridge superstructure) at the position of the beam under consideration as follows: 1 deck – 20,0 2 decks – 13,3 3 decks – 10,5 4 decks or more – 9,3 For a forecastle deck, <i>K₁</i> is to be taken as 13,3	
<i>b</i> = 1,4 for rolled or built sections = 1,6 for flat bars	<i>K₃</i> = a factor dependent on the location of the beam as follows: Span adjacent to ship's side – 3,6 Elsewhere – 3,3	
<i>h₁</i> = weather head, in metres, as defined in <i>Pt 3, Ch 3, 5 Design loading</i>		
<i>h₄</i> = tank head, in metres, as defined in <i>Pt 3, Ch 3, 5 Design loading</i>		
<i>l_e</i> as defined in <i>Pt 3, Ch 5, 1.4 Symbols and definitions 1.4.1</i> , but is to be taken not less than 1,83 m	<i>B₁</i> = <i>B</i> , but need not be taken greater than 21,5 m	
<p>Note 1. Beams at the upper deck inside superstructures are to have scantlings determined as for a lower deck, see <i>Table 1.4.5 Strength/weather, cargo and accommodation deck beams</i>.</p> <p>Note 2. Where weather decks are intended to carry deck cargo and the loading is in excess of 8,5 kN/m² (0,865 tonne-f/m²), the scantlings of beams are also to comply with the requirements for location (2) in <i>Table 1.4.5 Strength/weather, cargo and accommodation deck beams</i> using the equivalent design head, for specified cargo loadings, for weather decks given in <i>Table 3.5.1 Design heads and permissible cargo loadings</i>.</p> <p>Note 3. The web depth of beams, <i>d_w</i>, is to be not less than 60 mm.</p> <p>Note 4. The scantlings of deck beams forward in way of the cargo tanks of oil tankers or ore carriers will be specially considered, see <i>Pt 4, Ch 9, 1.4 Class notation and applicable Rules for non-CSR Double Hull Oil Tankers 1.4.11</i>.</p>		

Table 5.2.5 Spacing of girders and transverses under strength/weather decks forward

Location	Maximum spacing	
	Girders in association with transverse framing system	Transverses in association with longitudinal framing system

(1) Forward of the collision bulkhead	3,7 m	
(2) Between the collision bulkhead and 0,075L from the F.P.	3,7 m	2,5 m where $L \leq 100$ m 3,5 m where $L \geq 300$ m Intermediate values by interpolation
(3) In way of a deep tank, forward of 0,2L from the F.P.	—	3,0 m where $L \leq 100$ m 4,2 m where $L \geq 300$ m Intermediate values by interpolation
(4) Elsewhere in way of dry cargo spaces or deep tanks, see Note 1	—	3,8 m where $L \leq 100$ m (3,2 + 0,006L) m where $L > 100$ m
<p>Note 1. For the maximum spacing of transverses in the cargo tanks of oil tankers or ore carriers, see Pt 4, Ch 9, 9 Primary members supporting longitudinal framing.</p> <p>Note 2. For the maximum spacing of transverses in dredgers, see Pt 4, Ch 12, 5 Shell envelope framing.</p>		

■ *Section 3*
Shell envelope plating

3.1 General

3.1.1 Where the shell is longitudinally framed in the midship region, this system of framing is to be carried as far forward as practicable. In the case of oil tankers (see Pt 3, Ch 5, 1.1 Application 1.1.4), longitudinal framing is to extend at least to the forward end of the cargo tanks.

3.2 Keel

3.2.1 The scantlings of bar keels at the fore end are to be the same as in the midship region as required by Pt 4, Ch 1, 5 Shell envelope plating.

3.2.2 The thickness and width of plate keels in the forward region are to be the same as required in the midship region for the particular type of ship concerned, see Pt 4 Ship Structures (Ship Types).

3.3 Stem

3.3.1 Bar stems may be either steel castings or steel forgings complying with the requirements of Ch 3 Rolled Steel Plates, Strip, Sections and Bars of the Rules for Materials for rolled steel flat bars or Ch 5 Steel Forgings of the Rules for Materials for solid round bars. The scantlings of bar stems are to comply with Table 5.3.1 Shell plating forward.

3.3.2 The scantlings of plate stems are to be determined from Table 5.3.1 Shell plating forward. Plate stems are to be supported by horizontal diaphragms positioned in line with the side stringers or perforated flats with intermediate breasthook diaphragms. Diaphragms are to be spaced not more than 1,5 m apart, measured along the stem. Where the stem plate radius is large, a centreline stiffener or web will be required.

3.4 Bottom shell and bilge

3.4.1 The thickness of bottom shell and bilge plating in the forward region for ships not requiring additional strengthening of bottom is to comply with Table 5.3.1 Shell plating forward.

3.4.2 For thickness of bottom shell and keel when additional bottom strengthening is required, see Pt 3, Ch 5, 1.5 Strengthening of bottom forward.

3.4.3 Where longitudinals are omitted in way of radiused bilge plating amidships, the plating thickness forward will be considered in relation to the support derived from the hull form and internal stiffening arrangements.

3.5 Side shell and sheerstrake

3.5.1 The thickness of side shell and sheerstrake plating in the forward region is to be not less than the values given in *Table 5.3.1 Shell plating forward*, but may be required to be increased locally on account of high shear forces, in accordance with *Pt 3, Ch 4, 6.5 Permissible still water shear force*.

3.5.2 For transversely framed side shells where panting stringers are omitted, see *Pt 3, Ch 5, 4.4 Panting stringers in way of transverse framing*, the side shell plating in the region concerned is to be increased in thickness by the percentages given below:

- (a) 15 per cent, where $L \leq 150$ m
- (b) 5 per cent, where $L \geq 215$ m

For intermediate values of L , the percentage increase is to be obtained by interpolation.

3.5.3 The side shell plating of increased thickness required by *Pt 3, Ch 5, 3.5 Side shell and sheerstrake 3.5.2* is to be continued forward past the fore peak or collision bulkhead. In addition, horizontal brackets in line with the fore peak stringers are to be fitted at the aft side of the bulkhead where practicable. The brackets are to be the same thickness as the side shell and are to extend from the bulkhead to the adjacent shell frame and be connected thereto. Transversely the toes of the brackets are to extend past the outboard stiffener of the bulkhead to clear any cut out in the bulkhead stringer.

3.5.4 The sheerstrake taper thickness is to be increased by 20 per cent at the ends of a bridge superstructure extending out to the ship's side irrespective of position. Similar strengthening is to be fitted in way of the end of a forecastle if this occurs at a position aft of $0,25L$ from the F.P. No increase is required if the forecastle end bulkhead lies forward of $0,2L$ from the F.P. The increase at intermediate positions of end bulkhead is to be obtained by interpolation.

3.5.5 The shell plating may be required to be increased in thickness locally in way of hawse pipes, see *Pt 3, Ch 13, 8.10 Structural requirements associated with anchoring*.

3.5.6 The shell plating is to be increased in thickness locally in way of a bulbous bow, see *Pt 3, Ch 5, 6.5 Bulbous bow 6.5.6*.

3.6 Shell openings

3.6.1 In general, compensation will not be required for holes in the sheerstrake which are clear of the gunwale, or for any deck openings situated outside the line of main hatchways and whose depth does not exceed 20 per cent of the depth of the sheerstrake or 380 mm, whichever is the lesser. Openings are not to be cut in a rounded gunwale. Cargo door openings are to have well rounded corners, and the proposed compensation for the door openings will be individually considered.

3.6.2 Sea inlet and other openings are to have well rounded corners. The thickness of sea inlet box plating is generally to be the same as the adjacent shell. It is however, to be not less than 12,5 mm, and need not exceed 25 mm.

Table 5.3.1 Shell plating forward

Location		Thickness, in mm	
(1)	Bottom shell and bilge, see also 1.5 and Note 5:		Note 1. For ships where $L \leq 70$ m this thickness may be reduced by 1 mm, but it is to be not less than 6 mm.
(a)	Forward of $0,075L$ from the F.P.	$t = (6,5 + 0,033L) \sqrt{\frac{ks_1}{s_b}}$ (see Note 1)	Note 2. The taper thickness is to be determined from <i>Table 3.2.1 Taper requirements for hull envelope</i>
(b)	Between $0,075L$ and $0,25L$ from the F.P., see Note 7	As (1)(a) or the taper thickness, whichever is the greater	Note 3. For thickness of shell plating in way of the cargo and fore peak tanks of oil tankers or ore carriers, see also <i>Pt 4, Ch 9 Double Hull Oil Tankers, Pt 4, Ch 10 Single Hull Oil Tankers or Pt 4, Ch 11 Ore Carriers</i> , as appropriate.

(c)	Aft of 0,25L from the F.P., see Note 7	The taper thickness, (see Note 2)	<p>Note</p> <p>4. In offshore supply ships the thickness of side shell is to be not less than 9 mm.</p>
(2)	Side shell, see Notes 4 and 5:		
(a)	Forward of 0,75L from the F.P.	$t = (6,5 + 0,033L) \sqrt{\frac{ks_1}{s_b}}$ (see Note 1)	<p>Note</p> <p>5. For trawlers and fishing vessels see Pt 4, Ch 6, 5 Shell envelope plating.</p> <p>Note</p> <p>6. For fast cargo ships, see Pt 4, Ch 1, 3 Longitudinal strength.</p> <p>Note</p> <p>7. For oil tankers the thickness is also to be in accordance with Pt 4, Ch 9, 4.3 Deck plating 4.3.3.</p>
(b)	Between 0,075L and 0,2L from the F.P., see also Pt 3, Ch 5, 3.5 Side shell and sheerstrake 3.5.2	As (2)(a) or the taper thickness, whichever is the greater	
(c)	Aft of 0,2L from the F.P.	The taper thickness, (see Note 2)	
(3)	Sheerstrake, see Notes 4 and 5:		<p>Note</p> <p>8. The taper requirements from Table 3.2.1 Taper requirements for hull envelope in Pt 3, Ch 3 Structural Design do not apply to container ships or open ship types, see Pt 3, Ch 4, 2.3 Open type ships, where the requirements of Pt 4, Ch 8, 3.2 Longitudinal strength are applicable, nor to fast cargo ships where the requirements of Pt 4, Ch 1, 3 Longitudinal strength are applicable. See also Pt 3, Ch 4, 5 Hull bending strength for hull section modulus requirement away from the midship area.</p>
(a)	Forward of 0,075L from the F.P.:		
	where $\frac{T}{D} > 0,7$	As (2)(a) for side shell	
	where $\frac{T}{D} \leq 0,7$	As (4) for a forecastle	
(b)	Between 0,075L and 0,2L from the F.P., see Note 7	As (3)(a) or as determined from Table 3.2.1 in Chapter 3	
(c)	Aft of 0,2L from the F.P., see Note 7	The taper thickness, (see Note 2)	
(4)	Forecastle, see Notes 4 and 5	$t = (7,0 + 0,02L) \sqrt{\frac{ks_1}{s_b}}$	
(5)	Stem, see Notes 4 and 5		
(a)	Bar stem: below load waterline	$A_1 = (1,6L - 32) \text{ cm}^2 \text{ or } L \text{ cm}^2$ whichever is the greater	
	at stem head	$A_2 = 0,75 A_1 \text{ cm}^2$	
(b)	Plate stem: below load waterline	$t = (5,0 + 0,083L_2) \sqrt{k}$ mm	
	at stem head	$t = \text{as (2)(a) for side shell}$	
Symbols			
<p>L, B, D, T, s, k as defined in Pt 3, Ch 5, 1.4 Symbols and definitions 1.4.1</p> <p>s₁ = s, but to be taken as not less than s_b</p> <p>s_b = standard frame spacing, in mm, as follows:</p>			
Region	Bottom shell s _b	Side shell s _b	
Forward of 0,05L from the F.P.	$(470 + \frac{L}{0,6}) \text{ or } 600^*$	$(470 + \frac{L}{0,6}) \text{ or } 600^*$	
Between 0,05L and 0,2L from the F.P.	$(470 + \frac{L}{0,6}) \text{ or } 700^*$	$(470 + \frac{L}{0,6}) \text{ or } 700^*$	

Between 0,2L and 0,25L from the F.P.	$\left(510 + \frac{L_2}{0,6} \right)$	* whichever is the lesser
A_1 = cross-sectional area of bar stem below load waterline, in cm ²		
A_2 = cross-sectional area of bar stem at stem head, in cm ²		
L_2 = L, but need not be taken greater than 215 m		

■ **Section 4**
Shell envelope framing

4.1 General

4.1.1 Requirements are given in this Section for both longitudinal and transverse framing systems. Where longitudinal framing is adopted in the midship region it is to be carried as far forward as practicable. In the case of oil tankers (see Pt 3, Ch 5, 1.1 Application 1.1.4), longitudinal framing is to be continued at least to the fore end of the cargo tanks.

4.1.2 End connections of longitudinals to bulkheads are to provide adequate fixity, lateral support and, so far as practicable, direct continuity of longitudinal strength, see also Pt 3, Ch 10, 3 Secondary member end connections. Where L exceeds 215 m, the bottom longitudinals are to be continuous in way of both watertight and non-watertight floors, but alternative arrangements will be considered. Higher tensile steel longitudinals within 10 per cent of the ship's depth at the bottom and deck are to be continuous irrespective of the ship length.

4.1.3 Stiffeners and brackets on side transverses, where fitted on one side and connected to higher tensile steel longitudinals between the base line and 0,8D above the base line, are to have their heels well radiused to reduce stress concentrations. Where a symmetrical arrangement is fitted, i.e. bracket or stiffening on both sides, and it is connected to higher tensile steel longitudinals, the toes of the stiffeners or brackets are to be well radiused. Alternative arrangements will be considered if supported by appropriate direct calculations.

4.1.4 Where higher tensile steel side longitudinals pass through transverse bulkheads in the cargo area, well radiused brackets of the same material are to be fitted on both the fore and aft side of the connection between the upper turn of bilge and 0,8D above the base line. Particular attention is to be given to ensuring the alignment of these brackets. Alternative arrangements will be considered if supported by appropriate direct calculations.

4.1.5 For ships intended to load or unload while aground, see Pt 3, Ch 9, 7 Bottom strengthening for loading and unloading aground.

4.2 Shell longitudinals

4.2.1 The scantlings of bottom and side shell longitudinals in the forward region are to comply with the requirements given in Pt 3, Ch 5, 4.2 Shell longitudinals 4.2.1. For the scantlings of bottom shell longitudinals where additional bottom strengthening is required, see Pt 3, Ch 5, 1.5 Strengthening of bottom forward.

Table 5.4.1 Shell framing (longitudinal) forward

Location	Modulus, in cm ³
(1) Side longitudinals in forecastle	$Z = 0,0075s k l_e^2(0,6 + 0,167D_1)$
(2) Side longitudinals in way of dry spaces including double skin construction:	
(a) Forward of the collision bulkhead	$Z = 0,007s k h_{T1} l_e^2 F_s$ but not to be less than as required by (1)
(b) Between the collision bulkhead and 0,2L from the F.P.	As (a) above or as required in the midship region for the particular type of ship concerned, whichever is the greater. However, not to be taken less than as required by (1).

(c) Aft of 0,2L from the F.P.	As required in the midship region for the particular type of ship concerned.
(3) Side longitudinals in way of double skin tanks or deep tanks	The greater of the following: (a) Z as from (2) (b) As required by Pt 4, Ch 1, 9 Bulkheads for deep tanks.
(4) Bottom and bilge longitudinals	The greater of the following: (a) As required in the midship region for the particular type of ship concerned. (b) As required by Pt 3, Ch 5, 1.5 Strengthening of bottom forward, strengthening of bottom forward, where applicable.
Symbols	
<p>L, D, T, s, k, as defined in Pt 3, Ch 5, 1.4 Symbols and definitions 1.4.1</p> <p>l_{\bullet} = as defined in Pt 3, Ch 5, 1.4 Symbols and definitions 1.4.1, but is to be taken not less than 1,5m</p> <p>L_1 = L but need not be taken greater than 190 m</p> <p>F_s is a fatigue factor to be taken as follows:</p> <p>(a) For built sections and rolled angle bars:</p> $F_s = \frac{1,1}{k} \left[1 - \frac{2bf_1}{b_f} (1 - k) \right] \text{ at } 0,6D_1 \text{ above the base line}$ <p>= 1,0 at D_1 and above, and F_{sb} at the base line intermediate values by linear interpolation</p> <p>F_{sb} is a fatigue factor for bottom longitudinals</p> <p>= 0,5 (1 + F_s at 0,6D_1)</p> <p>(b) For flat bars and bulb plates $\frac{bf_1}{b_f}$ may be taken as 0,5</p> <p>where</p> <p>b_{f1} = the minimum distance, in mm, from the edge of the face plate of the side longitudinal under consideration to the centre of the web plate, see Fig. 9.5.1 in Pt 4, Ch 9</p> <p>b_f = the width of the face plate, in mm, of the side longitudinal under consideration, see Fig. 9.5.1 in Pt 4, Ch 9</p> <p>T_1 = T but not to be taken less than 0,65D_1</p> <p>D_1 = $T + H_b$ metres, where H_b is the minimum bow height, in metres, obtained from Pt 3, Ch 1, 6.1 Principal particulars 6.1.11</p> <p>h_{T1} = $f_w C_w \left(1 - \frac{h_6}{D_1 - T_1} \right) F_{\lambda} F_{\lambda'}$, in metres, for longitudinals above the waterline at draught T_1 where</p> <p>$f_w \left(1 - \frac{h_6}{D_1 - T_1} \right)$ is not to be taken less than 0,7</p> <p>= $\left[h_6 + f_w C_w \left(1 - \frac{h_6}{2T_1} \right) \right] F_{\lambda}$, in metres, for longitudinals below the waterline at draught T_1</p>	

where

$$f_w = 1,0 \text{ at } 0,2L \text{ from the F.P. and } 1,71 \text{ at, and forward of, } 0,15L \text{ from the F.P. Intermediate positions by interpolation}$$

$$h_b = \text{vertical distance, in metres, from the waterline at draught } T_1, \text{ to the longitudinal under consideration}$$

$$F_\lambda = 1,0 \text{ for } L \leq 200 \text{ m}$$

$$= [1,0 + 0,0023 (L - 200)] \text{ for } L > 200 \text{ m}$$

$$C_w = \text{a wave head, in metres} = 7,71 \times 10^{-2} L e^{-0,0044L}$$

where

$$e = \text{base of natural logarithms } 2,7183$$

NOTE

Where struts are fitted midway between transverses in double skin construction, the modulus of the side longitudinals may be reduced by 50k per cent from that obtained for locations (2) and (3) as applicable.

4.2.2 End connections of longitudinals to bulkheads are to provide adequate fixity, lateral support and so far as practicable, direct continuity of longitudinal strength, *see also Pt 3, Ch 10, 3 Secondary member end connections.*

4.3 Shell framing

4.3.1 The scantlings of side frames in the forward region are to comply with the requirements given in *Pt 3, Ch 5, 4.4 Panting stringers in way of transverse framing 4.4.3.*

4.3.2 The scantlings of main frames are normally to be based on Rule standard brackets at top and bottom, whilst the scantlings of 'tween deck frames are normally to be based on a Rule standard bracket at the top only.

4.3.3 End connections of transverse main and 'tween deck frames are to be in accordance with *Pt 3, Ch 10, 3 Secondary member end connections.* For bulk carriers the end connections of main frames in cargo holds are to be in accordance with *Pt 4, Ch 7, 6.2 Transverse stiffening 6.2.5 to Pt 4, Ch 7, 6.2 Transverse stiffening 6.2.12.* Where brackets are omitted at the foot of main frames in cargo spaces, small easing brackets are to be fitted forward of 0,15L from the F.P.

4.4 Panting stringers in way of transverse framing

4.4.1 In lower hold or deep tank spaces panting stringers are generally to be fitted in line with each stringer or flat in the fore peak space and extending back to 0,15L from the F.P. These stringers may be omitted if the shell plating is increased in thickness as required by *Pt 3, Ch 5, 3.5 Side shell and sheerstrake 3.5.2.* Where the span of the main frames exceeds 9 m, panting stringers are to be fitted irrespective of whether the shell plating is increased in thickness or not. These stringers are to be arranged in line with alternate stringers or flats in the fore peak and are to extend back to 0,2L from the F.P.

4.4.2 In 'tween deck spaces in the region forward of 0,15L from the F.P., where the unsupported length of frame exceeds 2,6 m in a lower 'tween deck or 3,0 m in an upper 'tween deck, intermediate panting stringers are generally to be fitted. These stringers may be omitted if the shell plating is increased in thickness as required by *Pt 3, Ch 5, 3.5 Side shell and sheerstrake 3.5.2.*

4.4.3 The scantlings of panting stringers are to be determined from *Pt 3, Ch 5, 4.4 Panting stringers in way of transverse framing 4.4.3.*

Table 5.4.2 Shell framing (transverse) forward

Location	Modulus, in cm ³	Inertia, in cm ⁴
(1) Frames in fore peak spaces and lower 'tween decks over, <i>see Note 1</i>	$Z = K_1 s k T D_2 S_1 \times 10^{-3}$	$I = \frac{3,5}{k} S_1 Z$

(2) Frames in upper 'tween decks and forecastles forward of the collision bulkhead, see Notes 1, 2 and 8	The greater of the following: (a) $Z = C s k h_{T1} H^2 \times 10^{-3}$ (b) $Z = 9,1 s k D_1 \times 10^{-3}$	$I = \frac{3,5}{k} HZ$
(3) Main and 'tween deck frames (including forecastle) between the collision bulkhead and 0,15L from the F.P., see Notes 1 to 4 and 8	The greater of the following: (a) $Z = C s k h_{T1} H^2 \times 10^{-3}$ (b) $Z = 9,1 s k D_1 \times 10^{-3}$	$I = \frac{3,5}{k} HZ$
(4) Main and 'tween deck frames between 0,15L and 0,2L from the F.P. in dry cargo spaces, see Notes 1 to 4 and 8	The greater of the following: (a) $Z = C s k h_{T1} H^2 \times 10^{-3}$ (b) $Z = 9,1 s k D_1 \times 10^{-3}$	$I = \frac{3,2}{k} HZ$
(5) Panting stringers, see Note 5	Web depth, d_w , same depth as frames Web thickness, $t = 6 + 0,025L_2$ mm Face area, $A = kS_2 (H + 1)$ cm ²	
(6) Main and 'tween deck frames elsewhere, see Notes 1 to 4	As required in the midship region for the particular type of ship concerned	
Symbols		
<i>L, D, T, s, k as defined in Pt 3, Ch 5, 1.4 Symbols and definitions 1.4.1</i>		
$L_2 = L$, but need not be taken greater than 215 m		
$D_1 = T + H_b$, in metres, where H_b is defined in Pt 3, Ch 1, 6.1 Principal particulars 6.1.11		
$D_2 = D_1$, but is to be taken not greater than 16 m, nor less than 6,0 m		
$H = H_{MF}$ or H_{TF} as applicable, see Note 7		
H_{MF} = vertical framing depth, in metres, of main frames as shown in Fig. 5.4.1 but is to be taken not less than 3,5 m, see Note 6		
H_{TF} = vertical framing depth, in metres, of 'tween deck frames as shown in Fig. 5.4.1 but is to be taken not less than 2,5 m		
$K_1 = 2,3$ for peak tanks = 1,87 for 'tween decks over peak tanks		
S_1 = vertical spacing of peak stringers or height of lower 'tween deck above the peak, in metres, as applicable		
S_2 = vertical spacing of panting stringers, in metres		
C = end connection factor		
= 3,4 where two Rule standard brackets fitted		
= 3,4 (1,8 - 0,8(l_a/l)) where one Rule standard bracket and one reduced bracket is fitted		
= 3,4 (2,15 - 1,15 (l_{amean}/l)) where two reduced brackets are fitted		
= 6,1 where one Rule standard bracket is fitted		
= 6,1 (1,2 - 0,2 (l_a/l)) where one reduced bracket is fitted.		
= 7,3 where no brackets are fitted		
= The requirements for frames where brackets larger than Rule standard are fitted will be specially considered		

l = length, in mm, as derived from Pt 3, Ch 10, 3.4 Scantlings of end brackets 3.4.1

l_a = equivalent arm length, in mm, as derived from Pt 3, Ch 10, 3.4 Scantlings of end brackets 3.4.1

l_{amean} = mean equivalent arm length, in mm, for both brackets

T_1 = T but not to be taken less than $0,65D_1$

h_{T_1} = head, in metres, at mid-length of H

= $f_w C_w \left(1 - \frac{h_6}{D_1 - T_1}\right) F_\lambda$, in metres for frames where the mid-length of frame is above the waterline, at draught T_1

where $f_w \left(1 - \frac{h_6}{D_1 - T_1}\right)$ is not to be taken less than 0,7

= $\left[h_6 + f_w C_w \left(1 - \frac{h_6}{2T_1}\right) \right] F_\lambda$, in metres for frames where the mid-length of frame is below the waterline at draught T_1

where

f_w = 1,0 at 0,2L from F.P. and 1,71 at, and forward of, 0,15L from F.P. Intermediate positions by interpolation

h_6 = vertical distance, in metres, from the waterline at draught T_1 to the mid-length of H

F_λ = 1,0 for $L \leq 200$ m

= $[1,0 + 0,0023 (L - 200)]$ for $L > 200$ m

C_w = a wave head, in metres

= $7,71 \times 10^{-2} L e^{-0,0044L}$

where e = base of natural logarithms 2,7183

NOTES

- For framing in the fore end of fishing vessels, see Pt 4, Ch 6, 6 Shell envelope framing
- In offshore supply ships the moduli of main and 'tween deck frames are to be 25 per cent greater than given in (2), (3) and (4).
- In way of the cargo tanks of oil tankers or ore carriers, the scantlings of frames are also to comply with the requirements for frames in the midship region of such ships, see Pt 4, Ch 9 Double Hull Oil Tankers, Pt 4, Ch 10 Single Hull Oil Tankers or Pt 4, Ch 11 Ore Carriers, as applicable.
- In bulk carriers the scantlings of frames are also to comply with the requirements of Pt 4, Ch 7, 6 Shell envelope framing in which the requirements of Table 7.6.1 location (1) are to be multiplied by the following factor:
Between 0,15L and 0,2L from the F.P., $C_1 = (0,018D_2 + 0,82)$, but not to be taken less than 1,0.
Between collision bulkhead and 0,15L from the F.P., $C_1 = (0,021D_2 + 0,96)$.
- Panting stringers are not required in tugs less than 46 m in length, see Pt 4, Ch 3, 4 Panting and strengthening of bottom forward.
- Where the frames are supported by fully effective horizontal stringers, these may be considered as decks for the purpose of determining H_{MF} .
- Where frames are inclined at more than 15° to the vertical, H_{MF} or H_{TF} is to be measured along a chord between span points of the frame.
- Except for main frames the modulus for these members need not exceed that derived from (1) using H_{TF} in place of S_1 .

4.5 Primary structure at sides

4.5.1 For the arrangement of primary structure in peak tanks and deep tanks forward, see also Pt 3, Ch 5, 6 Fore peak structure and Pt 3, Ch 5, 7 Forward deep tank structure.

4.5.2 The spacing of side transverses and web frames is generally not to exceed the values given in Table 5.4.3 Spacing of side transverses and web frames forward.

Table 5.4.3 Spacing of side transverses and web frames forward

Location	Maximum spacing	
	Web frames in association with transverse framing system	Side transverses in association with longitudinal framing system
(1) Forward of the collision bulkhead	5 frame spaces	2,5 m where $L \leq 100\text{m}$ 3,5 m where $L \geq 300$ Intermediate values by interpolation
(2) In way of a forward deep tank adjacent to the collision bulkhead	5 frame spaces	3,0 m where $L \leq 100\text{m}$ 4,2 m where $L \geq 300\text{m}$ Intermediate values by interpolation
(3) Elsewhere in way of dry cargo spaces or deep tanks	See Note 1	3,8 m where $L \leq 100\text{m}$ (0,006L + 3,2) m where $L > 100\text{m}$
(4) In way of the cargo tanks of oil tankers, chemical tankers or ore or oil carriers	—	3,6 m where $L \leq 180\text{ m}$ 0,02L where $L > 180\text{ m}$
Note 1. In 'tween decks above deep tanks situated adjacent to the collision bulkhead, web frames are to be fitted in line with those in the tanks.		
Note 2. For the maximum spacing of transverses in dredgers, see Pt 4, Ch 12, 5 Shell envelope framing		

4.5.3 The scantlings of side transverses supporting longitudinal framing and stringers and webs supporting transverse framing in the forward region are to be determined from Table 5.4.4 Primary structure forward.

Table 5.4.4 Primary structure forward

Item and location	Modulus, in cm^3	Inertia, in cm^4
Longitudinal framing system		
(1) Side transverses in dry spaces forward of 0,2L from the F.P., see Note 5: (a) Holds (b) 'tween decks	$Z = 10kSh_{T1}l_e^2$ $Z = C_2kSTH_{TF} \sqrt{D}$	—
(2) Side transverses in peak and deep tanks forward of 0,2L from the F.P., see Notes 1 and 4: (a) where no struts fitted (b) where struts fitted	$Z = 14,1 \rho kSh_4l_e^2 \gamma$ or as (1) above, whichever is the greater As in Pt 4, Ch 9, 9 Primary members supporting longitudinal framing	$I = \frac{2,5}{k} l_e Z$
(3) Side transverses in dry spaces and deep tanks aft of 0,2L from the F.P.	As in Pt 4, Ch 1, 6 Shell envelope framing, see Notes 1 and 2	

Transverse framing system		
(4) Side stringers supported by webs in dry spaces forward of 0,2L from the F.P., see Note 3 or as (4) above, whichever is the greater	$Z = 7,75kSh_{T1}l_e^2$	—
(5) Side stringers supported by webs in peak or deep tanks forward of 0,2L from the F.P., see Notes 1 and 3	$Z = 11,7\rho kSh_4l_e^2$ or as (4) above, whichever is the greater	$I = \frac{2,5}{k}l_eZ$
(6) Web frames supporting side stringers forward of 0,2L from the F.P., see Notes 1, 2 and 3	Z to be determined from the calculations based on the following assumptions: (a) Fixed ends (b) Point loadings from stringers (c) Head γh_4 or γh_{T1} as applicable (d) Bending stress $\frac{93,2}{k} \text{ N/mm}^2 \left(\frac{9,5}{k} \text{ kgf/mm}^2 \right)$ (e) Shear stress $\frac{83,4}{k} \text{ N/mm}^2 \left(\frac{8,5}{k} \text{ kgf/mm}^2 \right)$	In deep tanks $I = \frac{2,5}{k}l_eZ$
(7) Web frames in 'tween decks, not supporting side stringers, forward of 0,2L from the F.P.	$Z = C_3kSTH_{TF}\sqrt{D}$	—
(8) Side stringers and web frames in dry spaces and deep tanks aft of 0,2L from the F.P.	As in Pt 4, Ch 1, 6 Shell envelope framing, see Notes 1 and 2	
Symbols		
<i>D, T, S, l_e, k, ρ</i> as defined in Pt 3, Ch 5, 1.4 Symbols and definitions 1.4.1		
B_f = bow fullness factor determined from Fig 5.4.3 to be taken as 1,0 for framing members located at and abaft 0,2L from the forward perpendicular		
h₄ = tank head, in metres, as defined in Pt 3, Ch 3, 5 Design loading		
h_{T1} = head, in metres, at mid-length of span		
= $f_W C_W \left(1 - \frac{h_6}{D_1 - T_1} \right) F_\lambda$, in metres, where the mid-length of span is above the waterline at draught <i>T₁</i>		
where $f_W \left(1 - \frac{h_6}{D_1 - T_1} \right)$ is not to be taken less than 0,7		
= $\left[h_6 + f_W C_W \left(1 - \frac{h_6}{2T_1} \right) \right] F_\lambda$, in metres, where the mid-length of span is below the waterline at draught <i>T₁</i>		
where		
f_W = 1,0 at 0,2L from F.P. and 1,71 at, and forward of, 0,15L from F.P. Intermediate positions by interpolation		
h₆ = vertical distance, in metres, from the waterline at draught <i>T₁</i> to the mid-length of span		
F_λ = 1,0 for <i>L</i> ≤ 200 m		
= [1,0 + 0,0023 (<i>L</i> - 200)] for <i>L</i> > 200 m		

$$C_W = \text{a wave head, in metres}$$

$$= 7,71 \times 10^{-2} L e^{-0,0044 L}$$

where e = base of natural logarithms 2,7183

$$D_1 = T + H_b, \text{ in metres, where } H_b \text{ is defined in Pt 3, Ch 1, 6.1 Principal particulars 6.1.11}$$

$$T_1 = T \text{ but not to be taken less than } 0,65D_1$$

C_2, C_3 = factors obtained from *Figure 5.4.2 Framing factors for primary members*

H_{TF} = vertical height of tween decks, in metres, as shown in *Pt 3, Ch 5, 4.5 Primary structure at sides 4.5.4*

γ is to be measured at the mid-span of the member as follows:

$$\gamma_1 = 1,0 \text{ at base line}$$

$$\gamma_2 = \text{bow fullness factor } (B_f) \text{ at } 0,6D \text{ above base}$$

$$\gamma_3 = \left(\frac{B_f - 1}{2} \right) + 1,0 \text{ at depth } D \text{ above base}$$

Intermediate values are to be determined by interpolation.

Minimum value = 1,0

Note 1. In way of the cargo tanks, fore peak tanks and dry spaces of oil tankers or ore carriers the scantlings of primary structure are to comply with the requirements of *Pt 4, Ch 9 Double Hull Oil Tankers*, *Pt 4, Ch 10 Single Hull Oil Tankers* or *Pt 4, Ch 11 Ore Carriers*, as appropriate.

Note 2. For bulk carriers see *Pt 4, Ch 7, 6.2 Transverse stiffening*.

Note 3. For stringers and webs in fore peaks or deep tanks, see also *Pt 3, Ch 5, 6.3 Side structure – Transverse framing* and *Pt 3, Ch 5, 7.3 Side structure – Transverse framing*.

Note 4. In the fore peak, the breadth S should be measured along the line of shell. The effective length l_e of the vertical webs should be measured along the line of shell from horizontal flat to horizontal flat, except that it may be taken to the underside of a transverse or strut where fitted.

Note 5. The web depth of side transverses forward of $0,2L$ from the F.P. is to be not less than 2,5 times the depth of the longitudinals supported. The web depth of stringers forward of $0,2L$ is to be not less than 2,2 times the depth of the frames supported.

Note 6. For the primary structure at sides in dredgers with restricted service notations, see *Table 12.5.2 Primary supporting structure at sides*.

4.5.4 The web thickness, stiffening arrangements and end connections of primary supporting members are to be in accordance with the requirements of *Pt 3, Ch 10, 4 Construction details for primary members*.

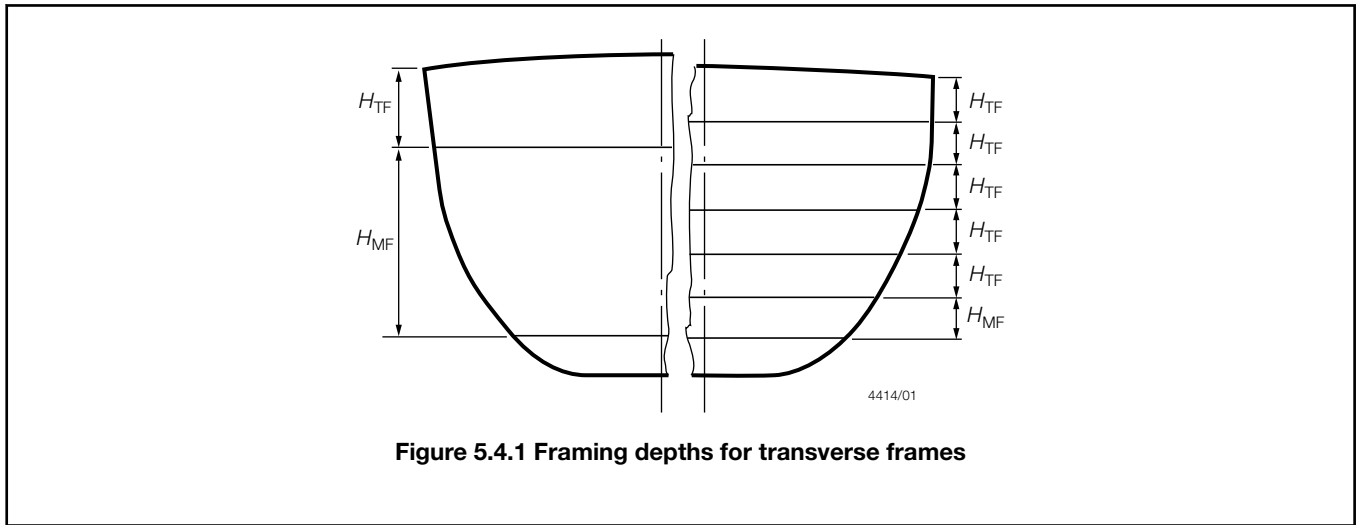

Figure 5.4.1 Framing depths for transverse frames

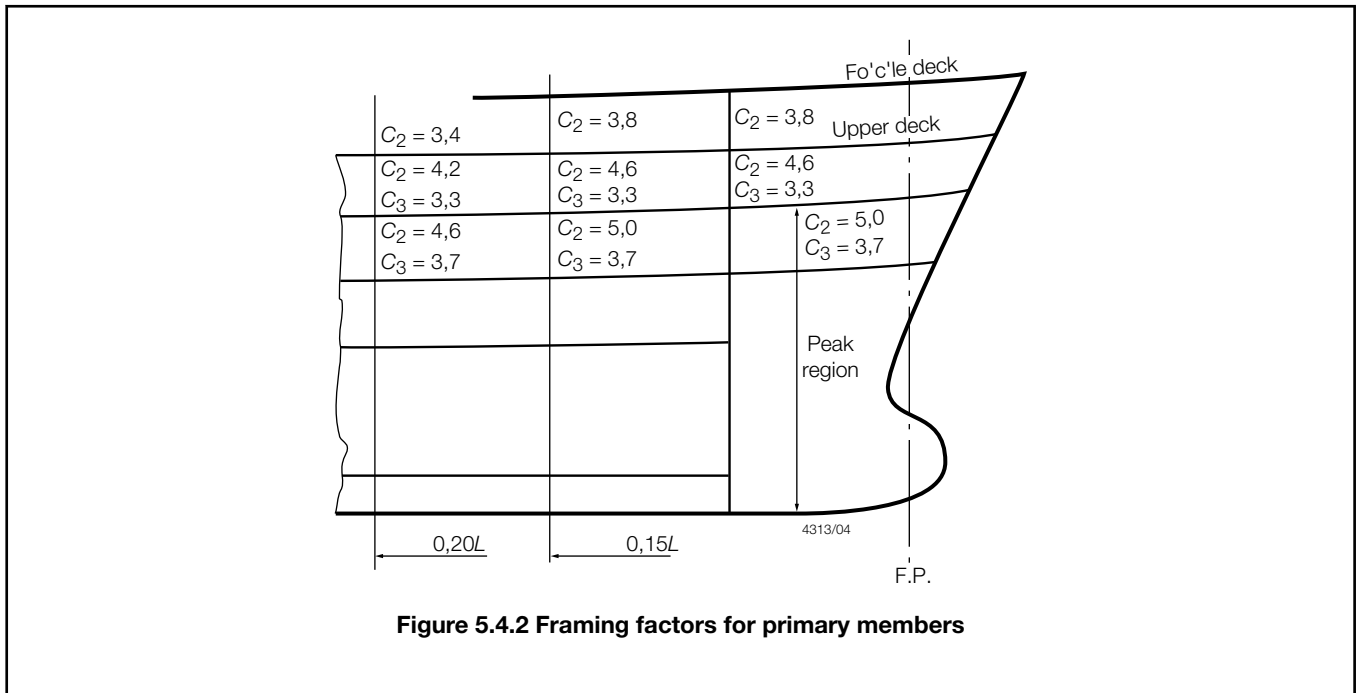
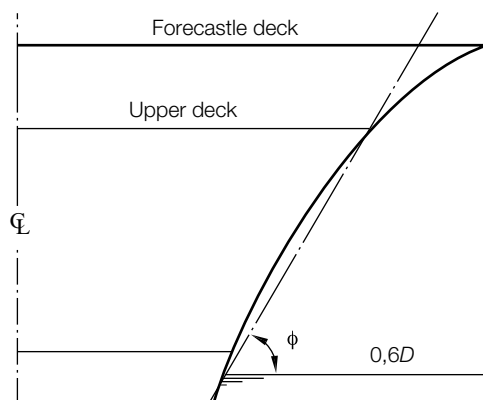

Figure 5.4.2 Framing factors for primary members



(a)

Conditions for ϕ

1. ϕ to be deduced at $0,025L$ aft of fore perpendicular
2. Aft of fore peak tank ϕ to be deduced at section being considered
3. For ships with a bulbous bow the angle ϕ is to be measured from the narrowest point of the bow between $0,6D$ from base and upper deck

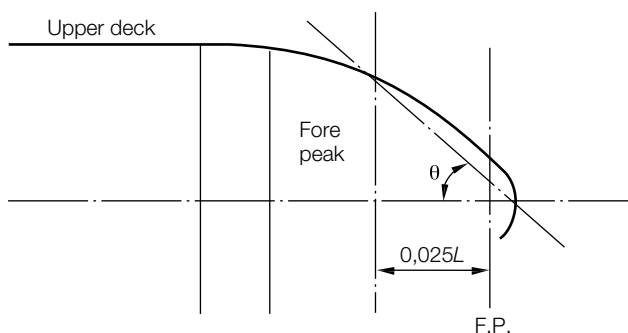

(b)

Bow fullness factor
 $B_f = 2,45 \cos \phi \tan \theta$
 but not to be taken less than 1,0

Figure 5.4.3 Illustration of bow fullness factor determination

■ **Section 5**
Single and double bottom structure

5.1 General

5.1.1 For dry cargo ships exceeding 120 m in length and for all ships which have the notation 'strengthened for heavy cargoes', longitudinal framing is, in general, to be adopted (see also Pt 4, Ch 9, 1.3 Class notation and applicable Rules for CSR Double Hull Oil Tankers and Pt 4, Ch 10 Single Hull Oil Tankers).

5.1.2 For ships requiring additional strengthening of bottom forward the requirements given in 1.5 are also to be complied with, as applicable.

5.1.3 For ships having the notation 'strengthened for heavy cargoes' the requirements of Pt 4, Ch 7, 8 Double bottom structure are also to be complied with, as applicable.

5.1.4 For ships intended to load or unload while aground, see Pt 3, Ch 9, 7 Bottom strengthening for loading and unloading aground.

5.1.5 Provision is to be made for the free passage of water and/or air from all parts of single or double bottoms to bilge or tank suction, account being taken of the pumping rates required.

5.1.6 For passenger ships, see Pt 4, Ch 2, 6 Double bottom.

5.2 Single bottoms – Transverse framing

5.2.1 In fore peak spaces, for ships of full form the floors are to be supported by a centreline girder or a centreline wash bulkhead. In other cases the centreline girder is to be carried as far forward as practicable. The arrangement and scantlings of the floors and centreline girder are to be sufficient to give adequate stiffness to the structure, but are to be not less than required by Table 5.5.1 Single bottom construction forward. The floor panels and the upper edges of the floors and centreline girder are to be suitably stiffened.

Table 5.5.1 Single bottom construction forward

Item	Parameter	Requirement
Transverse framing system		
(1) Centre girder:		The greater of the following:
(a) In fore peak tank, or deep tank, forward of 0,2L from the F.P.	Modulus	$Z = 8,5 k S h d_e^2 \text{ cm}^3$, or $Z = 9,75 \rho k S h d_e^2 \text{ cm}^3$
	Inertia	$I = \frac{2,5}{k} l_e Z \text{ cm}^4$
	Web thickness	$t = t_w$ as in Pt 3, Ch 10, 4.4 Geometric properties and proportions
(b) In dry spaces		Forward of 0,075L from the F.P.,
	Web thickness	$t = (\sqrt{Lk} + 0,5) \text{ mm}$ or 6 mm, whichever is the greater.
		Between 0,075L and 0,3L from the F.P. the thickness may taper from the midship thickness to the end thickness above
	Web depth and face area	As in Pt 4, Ch 1, 7 Single bottom structure
(2) Floors:		
(a) In fore peak tank, or deep tank, forward of 0,2L from the F.P.	Maximum spacing	Every frame
	Web depth (at centreline)	$d_f = (83D + 150) \text{ mm}$ or 1400 mm, whichever is the lesser
	Web thickness	$t = (6,0 + 0,025L_2) \sqrt{\frac{S_2}{800}} \text{ mm}$
	Minimum face plate area in deep tank	$A_f = 0,85kB \text{ cm}^2$
(b) In dry cargo spaces	Maximum spacing	Every frame
	Scantlings	As in Pt 4, Ch 1, 7.2 Girders and floors
(3) Intercostal side girders:		

(a) In deep tank, forward of 0,2L from the F.P.	Maximum spacing	0,003s _F m
	Web depth	As floors
	Web thickness	$t = t_w$ as in Pt 3, Ch 10, 4.4 Geometric properties and proportions
	Minimum face plate area	Suitable stiffener
(b) In dry cargo spaces	Maximum spacing	0,003s _F m
	Scantlings	As in Pt 4, Ch 1, 7 Single bottom structure
Longitudinal framing system		
(4) Centre girder:		
(a) In deep tanks forward of 0,2L from the F.P.	Scantlings	As in Pt 4, Ch 9, 9 Primary members supporting longitudinal framing
(b) In dry spaces	Scantlings	To be specially considered
(5) Bottom transverses:		
(a) In deep tanks forward of 0,2L from the F.P., see Note 4	Maximum spacing	3,0 m for $L \leq 100$ m 4,2 m for $L \geq 300$ m Spacing at intermediate lengths by interpolation
	Scantlings	As in Pt 4, Ch 9, 9 Primary members supporting longitudinal framing
(b) In dry spaces	Scantlings	To be specially considered
(6) Intercostal side girders	Scantlings	To be specially considered
Symbols		
L, B, D, S, I _e , k, ρ as defined in Pt 3, Ch 5, 1.4 Symbols and definitions 1.4.1		
h_4 = tank head, in metres, as defined in Pt 3, Ch 3, 5 Design loading		
h_5 = distance, in metres, from mid-point of span to the following positions:		
(a)	forward of 0,15L from the F.P., 3 m above the deck height obtained from Pt 3, Ch 1, 6.1 Principal particulars 6.1.11	
(b)	at 0,2L from the F.P. the upper deck at side	
(c)	between 0,15L and 0,2L from the F.P., by interpolation between (a) and (b)	
s_F = transverse frame spacing, in mm		
s_2 = spacing of stiffener, in mm, but to be taken not less than 800 mm		
L_2 = L but need not be taken greater than 215 m		
<p>Note 1. For single bottom construction in way of the cargo tanks of oil tankers, see Pt 4, Ch 9, 1.3 Class notation and applicable Rules for CSR Double Hull Oil Tankers and Pt 4, Ch 10 Single Hull Oil Tankers</p> <p>Note 2. For minimum thickness of structure within cargo tanks and fore peak tanks in oil tankers, see Pt 4, Ch 9, 10.2 Compartment minimum thickness and Pt 4, Ch 10, 7.2 Compartment minimum thickness.</p> <p>Note 3. For single bottom construction in dredgers, see Pt 4, Ch 12, 6 Bottom structure.</p> <p>Note 4. For ships having one or more longitudinal bulkheads the maximum spacing may be increased but is not to exceed that for the midship region.</p>		

5.2.2 In deep tanks forward of 0,2L from the F.P. floors are to be supported by a primary centreline girder or centreline bulkhead together with intercostal side girders. In the case of an oil tanker (see Pt 3, Ch 5, 1.1 Application 1.1.4) or similar ship having longitudinal bulkheads port and starboard, these may be extended to the fore end of the deep tank in lieu of a centreline bulkhead. The arrangement and scantlings of centreline girder, floors and side girders are to be determined from Table 5.5.1 *Single bottom construction forward*, but in way of web frames the depth of the floor and size of the face bar are to be not less than those of the web frame. In general, floors are not to be flanged.

5.2.3 In way of dry cargo spaces forward, the arrangement and scantlings of transversely framed single bottoms are to be generally as required in the midship region as given in Pt 4, Ch 1, 7 *Single bottom structure*, except as required by Table 5.5.1 *Single bottom construction forward*. The girders forward are to scarf into the normal girder arrangement in the midship region. In ships having considerable rise of floor towards the fore end, the depth of the floors may be required to be increased or the top edge sloped upwards towards the outboard end. In general, floors are not to be flanged.

5.3 Single bottoms – Longitudinal framing

5.3.1 In deep tanks forward of 0,2L from the F.P., bottom transverses are to be supported by a primary centreline girder or a centreline bulkhead. In addition, an intercostal side girder is generally to be fitted port and starboard. In the case of an oil tanker (see Pt 3, Ch 5, 1.1 Application 1.1.4) or similar ship having longitudinal bulkheads port and starboard, these may be extended to the fore end of the deep tank in lieu of a primary centreline support and intercostal girders. The spacing of bottom transverses and scantlings of the centreline girder, bottom transverses and side girders are to be as required by Table 5.5.1 *Single bottom construction forward*.

5.3.2 The requirements for longitudinally framed single bottoms in way of dry cargo spaces will be specially considered.

5.4 Double bottoms

5.4.1 The minimum depth of centre girder forward is generally to be the same as that required in the midship region by Pt 4 *Ship Structures (Ship Types)* for the particular type of ship concerned, but in ships with considerable rise of floor, a greater depth may be required at the fore end to provide adequate access throughout the double bottom tank.

5.4.2 Where the height of the double bottom varies, this variation is generally to be made gradual by sloping the inner bottom over an adequate longitudinal extent. Knuckles in the plating are to be arranged close to plate floors. Otherwise, suitable scarfing arrangements are to be made.

5.4.3 The arrangement and scantlings of girders, floors and inner bottom plating and the section modulus of inner bottom stiffening are to be determined from Table 5.5.2 *Double bottom construction forward*. In other respects the structural arrangements are to be as detailed in Pt 4 *Ship Structures (Ship Types)* for the particular type of ship concerned.

5.4.4 For double bottom construction in way of the cargo tanks of oil tankers or ore carriers, see also Pt 4, Ch 9 *Double Hull Oil Tankers*, Pt 4, Ch 10 *Single Hull Oil Tankers* or Pt 4, Ch 11 *Ore Carriers*, as appropriate.

Table 5.5.2 Double bottom construction forward

Item and parameter	Requirements	
	Transverse framing	Longitudinal framing
(1) Centre girder:	$t = (0,008d_{DB} + 2)\sqrt{k} \text{ mm}$	
(a) Thickness forward of 0,075L from the F.P.		
(b) Thickness between 0,075L and 0,3L from the F.P.	As determined by a taper line from the midship thickness given in Pt 4, Ch 1, 8 <i>Double bottom structure</i> to the end thickness as for (1) (a)	
(2) Plate floors:		
(a) Maximum spacing forward of 0,2L from the F.P.	0,002s _F m	2,5 m
(b) Maximum spacing aft of 0,2L from the F.P.	As for midship region	As for midship region (see Note 5)
(c) Scantlings	As in Pt 4, Ch 1, 8 <i>Double bottom structure</i>	As in Pt 4, Ch 1, 8 <i>Double bottom structure</i>

(3) Watertight floors and bracket floors	As in Pt 4, Ch 1, 8 Double bottom structure	As in Pt 4, Ch 1, 8 Double bottom structure
(4) Side girders, see Note 1:		
(a) Maximum spacing forward of 0,2L from the F.P.	0,003s _F m	0,004s _L or 3,7 m whichever is the lesser
(b) Maximum spacing aft of 0,2L from the F.P.	As for midship region	As for midship region, see Note 5
(c) Scantlings	As in Pt 4, Ch 1, 8 Double bottom structure	As in Pt 4, Ch 1, 8 Double bottom structure
(5) Inner bottom plating, see Note 2:		
(a) Thickness at or forward of 0,075L from the F.P.	$t = (0,00127(s + 660) \sqrt[4]{k^2 LT})$ mm or 6,5 mm, whichever is the greater, see Notes 3, 4 and 5	
(b) Thickness between 0,075L and 0,3L from the F.P.	As determined by a taper line from the midship thickness given in Pt 4, Ch 1, 8 Double bottom structure to the end thickness as for (5) (a), but not less than 6,5 mm, see Notes 3, 4 and 5	
(c) In way of deep tanks or holds used for the carriage of water ballast or where the double bottom tank is common with a wing ballast tank.	$t = (0,004 s f \sqrt{\frac{\rho k h_4}{1,025}} + 2,5)$ mm or 6,5 mm, whichever is the greater	
(6) Inner bottom longitudinals	As in Pt 4, Ch 1, 8 Double bottom structure, see Notes 2 and 5	
Symbols		
<p>L, T, S, s, k, ρ = as defined in Pt 3, Ch 5, 1.4 Symbols and definitions 1.4.1</p> <p>d_{DB} = minimum depth of centre girder as required by Pt 4, Ch 1, 8 Double bottom structure</p> <p>f = $1,1 - \frac{s}{2500S}$ but to be taken not greater than 1,0</p> <p>h₄ = tank head, in metres, as defined in Pt 3, Ch 3, 5 Design loading</p> <p>s_F = transverse frame spacing, in mm</p> <p>s_L = spacing of bottom longitudinals, in mm</p>		
<p>Note 1. The girders forward of 0,2L are to be suitably scarfed into the midship girder arrangement.</p> <p>Note 2. For double bottom construction in way of the cargo tanks of oil tankers or ore carriers, see also Pt 4, Ch 9 Double Hull Oil Tankers, Pt 4, Ch 10 Single Hull Oil Tankers or Pt 4, Ch 11 Ore Carriers, as appropriate.</p> <p>Note 3. In way of hatches the tank top taper thickness is to be increased by 2 mm if no ceiling is fitted, but is to be taken not less than 7,5 mm.</p> <p>Note 4. Where cargo is to be regularly discharged by grabs the tank top taper thickness is to be increased by 5,0 mm if no ceiling is fitted, or by 3,0 mm where ceiling is fitted.</p> <p>Note 5. For ships having the notation 'strengthened for heavy cargoes', the requirements of Pt 4, Ch 7, 8 Double bottom structure are also to be complied with.</p>		

■ **Section 6**
Fore peak structure

6.1 General

6.1.1 The requirements given in this Section apply to the arrangement of primary structure supporting the peak side framing and bulbous bow, the arrangement and scantlings of wash bulkheads and perforated flats, and the scantlings of collision bulkheads.

6.1.2 In ships of very full form it is recommended that transverse framing and side transverses supporting longitudinal framing, together with attached floors and beams, be inclined at an angle to the centreline of ship so that the frames or transverses lie as near normal to the shell plating as possible.

6.2 Bottom structure

6.2.1 The bottom of the peak space is generally to be transversely framed with arrangements and scantlings as detailed in *Pt 3, Ch 5, 5.2 Single bottoms – Transverse framing 5.2.1*. Longitudinally framed bottom structure will be specially considered.

6.3 Side structure – Transverse framing

6.3.1 Above the floors, transverse side framing is to be supported by one of the following arrangements:

- (a) Side stringers spaced about 2,0 m apart and supported by struts fitted at alternate frames. The struts are to be bracketed to the frames and where the span is long, supported at the centreline by a complete or partial wash bulkhead or equally effective structure. Intermediate frames are to be bracketed to the stringer plates.
- (b) Side stringers spaced about 2,0 m apart and supported by web frames. The upper ends of the web frames are to be supported under the tank top by suitable deep beams or buttresses which should generally form a ring structure.
- (c) Perforated flats spaced not more than 2,5 m apart. The area of perforations in each flat is to be not less than 10 per cent of the total area of the flat. The plating is to be suitably framed in way of openings.
- (d) A combination of the above arrangements.

6.3.2 Where the depth of the peak space exceeds 10 m, a perforated flat is to be arranged at about mid-depth.

6.3.3 Where the length of the space exceeds 10 m and the side framing is supported as required by *Pt 3, Ch 5, 6.3 Side structure – Transverse framing 6.3.1* or *Pt 3, Ch 5, 6.3 Side structure – Transverse framing 6.3.1*, additional transverse strengthening in the form of transverse wash bulkheads or web frames is to be provided.

6.3.4 The scantlings of side stringers supported by struts, and also of the struts and their brackets, are to be determined from *Table 5.6.1 Fore peak structure*.

Table 5.6.1 Fore peak structure

Item	Parameter	Requirement
(1) Unflanged stringers supported by panting beams at alternate frames	Web thickness	$t = (6,0 + 0,025L_2) \sqrt{\frac{S_1}{600}}$ mm
	Web depth	$d_w = (400 + 3,3L) \frac{S_1}{2,0}$ mm
(2) Struts	Cross-sectional area	$A = (2,5B_1 - 0,04L_2)k$ cm ²
	Least inertia	$I = S_1 S_2 h_5 l_e^2$ cm ⁴
(3) Brackets supporting stringers and beams	Thickness	$t = (6,0 + 0,025L_2) \sqrt{\frac{S_1}{600}}$ mm
	Arm length	$l_e = \frac{150A}{t}$ mm in way of struts $l_e = 0,5d_w$ mm at intermediate frames

(4) Perforated flats and wash bulkheads (excluding lowest strake of plating) see Notes 1, 2 and 3	Plating thickness Stiffener modulus	$t = (6,0 + 0,015L) \sqrt{\frac{s_2}{800}} \text{ mm}$ $Z = \frac{0,0057skh_6 l^2}{b} e \text{ cm}^3$
(5) Diaphragms in bulbous bows and lowest strake of wash bulkhead	Plating thickness	$t = (6,0 + 0,025L_2) \sqrt{\frac{s_2}{800}} \text{ mm}$
Symbols		
<p>L, B, S, s, k = as defined in Pt 3, Ch 5, 1.4 Symbols and definitions 1.4.1</p> <p>b = 1,4 for rolled or built sections = 1,6 for flat bars</p> <p>h₅ = vertical distance, in metres, from the stringer to a position 3 m above the deck height obtained from Pt 3, Ch 1, 6.1 <i>Principal particulars 6.1.11</i></p> <p>h₆ = vertical distance, in metres, from mid-depth of tank to top of tank</p> <p>l₆ = effective length of stiffening member, in metres, see Table 1.9.1 <i>Watertight and deep tank bulkhead scantlings</i> and Table 1.9.3 <i>Bulkhead end constraint factors</i> in Pt 4, Ch 1</p> <p>s₁ = spacing of peak frames, in mm, but to be taken not less than 600 mm</p> <p>s₂ = spacing of stiffeners, in mm, but to be taken not less than 800 mm</p> <p>B₁ = B, but need not be taken greater than 32 m</p> <p>L₂ = L, but need not be taken greater than 215 m</p> <p>S₁ = vertical spacing or mean spacing of stringers, in metres</p> <p>S₂ = horizontal spacing of struts, in metres</p>		
<p>Note 1. For oil tankers, see also Pt 4, Ch 9, 10.7 <i>Application of stiffening requirements</i></p>		
<p>Note 2. For horizontal flats supporting vertical webs in the fore peak tank, the thickness of the flat in way of the web is to comply with Table 9.7.1 <i>Transverse oiltight bulkhead scantlings</i>.</p>		
<p>Note 3. For minimum thickness within fore peak tanks of oil tankers, see also Pt 4, Ch 9, 10.2 <i>Compartment minimum thickness</i>.</p>		

6.3.5 The scantlings of side stringers supported by web frames, and also of the web frames, are to be determined from Pt 3, Ch 5, 4.5 *Primary structure at sides*.

6.3.6 The scantlings of perforated flats are to be determined from Table 5.6.1 *Fore peak structure*.

6.4 Side structure – Longitudinal framing

6.4.1 The spacing and scantlings of side transverses supporting longitudinal framing are to be as required by Pt 3, Ch 5, 4.5 *Primary structure at sides*.

6.4.2 Where the depth of a tank exceeds 10 m, side transverses are generally to be supported by one or more perforated flats or an arrangement of struts.

6.4.3 Suitable transverses or deep beams are to be arranged at the top of the tank and at perforated flats to provide end rigidity to the side transverses.

6.5 Bulbous bow

6.5.1 Where a bulbous bow is fitted, the structural arrangements are to be such that the bulb is adequately supported and integrated into the fore peak structure.

6.5.2 At the fore end of the bulb the structure is generally to be supported by horizontal diaphragm plates spaced about 1,0 m apart in conjunction with a deep centreline web.

6.5.3 In general, vertical transverse diaphragm plates are to be arranged in way of the transition from the peak framing to the bulb framing.

6.5.4 In way of a wide bulb, additional strengthening in the form of a centreline wash bulkhead is generally to be fitted.

6.5.5 In way of a long bulb, additional strengthening in the form of transverse wash bulkheads or substantial web frames spaced about five frame spaces apart are generally to be fitted.

6.5.6 The shell plating is to be increased in thickness at the fore end of the bulb and in other areas likely to be damaged by the anchors and chain cables. The increased plate thickness is to be the same as that required for plated stems by *Pt 3, Ch 5, 3.3 Stem 3.3.2*.

6.6 Wash bulkhead

6.6.1 Where a fore peak space is used as a tank and the breadth of the tank at its widest point exceeds $0,5B$, a complete or partial centreline wash bulkhead is to be fitted.

6.6.2 Wash bulkheads are to have an area of perforations not less than five per cent nor more than 10 per cent of the area of the bulkhead. The plating is to be suitably stiffened in way of openings.

6.6.3 The scantlings of wash bulkheads are to be determined from *Table 5.6.1 Fore peak structure*. Stiffeners are to be bracketed at top and bottom.

6.7 Collision bulkhead

6.7.1 The position and height of the collision bulkhead are to be in accordance with the requirements of *Pt 3, Ch 3, 4 Bulkhead requirements*.

6.7.2 The scantlings are to comply with the requirements of *Pt 4, Ch 1, 9 Bulkheads* except that the thickness of plating and modulus of stiffeners are to be not less than 12 per cent greater and 25 per cent greater, respectively, than would be required for a dry space. If the collision bulkhead forms the boundary of a cargo tank or cofferdam in an oil tanker or ore carrier the minimum thickness requirements of *Pt 4, Ch 9, 10 Construction details and minimum thickness* are also to be complied with.

6.7.3 Doors, manholes, permanent access openings or ventilation ducts are not to be cut in the collision bulkhead below the freeboard deck, *see also Pt 5, Ch 13, 3 Drainage of compartments, other than machinery spaces*. The number of openings in collision bulkheads above the freeboard deck is to be kept to a minimum compatible with the design and proper working of the ship. All such openings are to be fitted with means of closing to weathertight standards.

■ *Section 7***Forward deep tank structure****7.1 General**

7.1.1 The requirements given in this Section apply to the arrangement of primary structure supporting the side framing, the arrangement and scantlings of wash bulkheads and perforated flats, and the scantlings of boundary bulkheads in way of deep tanks situated forward of $0,2L$ from the F.P.

7.1.2 For deep tanks situated aft of this position, *see Pt 4, Ch 1, 9 Bulkheads*.

7.2 Bottom structure

7.2.1 The bottom structure is to comply with the requirements given in *Pt 3, Ch 5, 5.2 Single bottoms – Transverse framing 5.2.2, Pt 3, Ch 5, 5.3 Single bottoms – Longitudinal framing 5.3.1* and *Pt 3, Ch 5, 5.4 Double bottoms*, as applicable.

7.3 Side structure – Transverse framing

7.3.1 Above the floors, transverse framing is to be supported by one of the following arrangements:

- (a) Side stringers spaced not more than 5 m apart and supported by web frames. The upper ends of the web frames are to be supported under the tank top by suitable deep beams or buttresses which should generally form a ring system.
- (b) Side stringers spaced not more than 5 m apart and spanning from bulkhead to bulkhead. The ends of these stringers are to be connected to horizontal stringers on the transverse bulkheads to form a ring system.
- (c) In the case of narrow tanks, perforated flats spaced not more than 5 m apart. The area of perforations is to be not less than 10 per cent of the area of the flat, and the plating is to be suitably stiffened in way of openings.

7.3.2 Where the side framing is supported as required by *Pt 3, Ch 5, 7.3 Side structure – Transverse framing 7.3.1* and the depth of the tank exceeds 16 m, the web frames are to be supported by one of the following:

- (a) One or more side stringers spanning from bulkhead to bulkhead.
- (b) One or more perforated flats having deep beams or transverses in way of the web frames.
- (c) One or more cross ties.

7.3.3 Where the side framing is supported as required by *Pt 3, Ch 5, 7.3 Side structure – Transverse framing 7.3.1* and the length of the tank exceeds 14 m, additional transverse strengthening in the form of transverse wash bulkheads or web frames is to be provided.

7.3.4 The scantlings of stringers and web frames as required by *Pt 3, Ch 5, 7.3 Side structure – Transverse framing 7.3.1* are to be determined from *Pt 3, Ch 5, 4.5 Primary structure at sides*.

7.3.5 The scantlings of side stringers supporting framing as required by *Pt 3, Ch 5, 7.3 Side structure – Transverse framing 7.3.1* are to be determined from Item (5) in *Table 5.4.4 Primary structure forward*.

7.3.6 The scantlings of side stringers supporting web frames as required by *Pt 3, Ch 5, 7.3 Side structure – Transverse framing 7.3.2* are to be determined from Item (6) in *Table 5.4.4 Primary structure forward*.

7.3.7 The scantlings of perforated flats as required by *Pt 3, Ch 5, 7.3 Side structure – Transverse framing 7.3.1* or *Pt 3, Ch 5, 7.3 Side structure – Transverse framing 7.3.2* are to be determined from *Table 5.6.1 Fore peak structure*.

7.3.8 The scantlings of cross ties are to be determined as for cross ties in the cargo tanks of oil tankers, see *Pt 4, Ch 9, 9 Primary members supporting longitudinal framing*. Where the span between the side shell and longitudinal bulkhead exceeds 0,3B, additional fore and aft or vertical support for the struts may be required.

7.4 Side structure – Longitudinal framing

7.4.1 The spacing and scantlings of side transverses supporting longitudinal framing are to be as required by *Pt 3, Ch 5, 4.5 Primary structure at sides*.

7.4.2 Where the depth of the tank exceeds 16 m, the side transverses are to be supported as required by *Pt 3, Ch 5, 7.3 Side structure – Transverse framing 7.3.2*.

7.5 Wash bulkheads

7.5.1 Where the breadth of the tank at its widest point exceeds 0,5B, a centreline wash bulkhead is generally to be fitted. If the maximum breadth of tank exceeds 0,7B, it is recommended that the centreline bulkhead be made intact. In the case of an oil tanker or similar ship having longitudinal bulkheads port and starboard, these may be extended to the fore end of the deep tank in lieu of a centreline bulkhead.

7.5.2 Wash bulkheads are to have an area of perforations not less than 5 per cent nor more than 10 per cent of the area of the bulkhead. The plating is to be suitably stiffened in way of openings.

7.5.3 The scantlings of wash bulkheads are generally to be as required by *Table 5.6.1 Fore peak structure*, but see also *Pt 3, Ch 5, 7.5 Wash bulkheads 7.5.4* to *Pt 3, Ch 5, 7.5 Wash bulkheads 7.5.6*. Stiffeners are to be bracketed at top and bottom.

7.5.4 The thickness of longitudinal bulkheads may be required to be increased to ensure compliance with the shear strength requirements of *Pt 3, Ch 4, 6 Hull shear strength*. In the case of a centreline or perforated wing bulkhead, the proportion of the total shear force absorbed by the bulkhead will be specially considered.

7.5.5 The thickness of plating of wash bulkheads may also be required to be increased to take account of shear buckling.

7.5.6 Where longitudinal wash bulkheads support bottom transverses, the lower section of the bulkhead is to be kept free of non-essential openings for a depth equal to 1,75 times the depth of the transverses, and the plating thickness may be required to be increased to meet local buckling requirements.

7.6 Transverse boundary bulkheads

7.6.1 The transverse bulkheads forming the forward and after boundaries of the tank are generally to comply with the requirements of *Pt 4, Ch 1, 9 Bulkheads*, except that when the after bulkhead forms the boundary of a cargo tank or cofferdam in an oil tanker or ore carrier, the minimum thickness requirements of *Pt 4, Ch 9, 10 Construction details and minimum thickness* are also to be complied with.

Section

- 1 **General**
- 2 **Deck structure**
- 3 **Shell envelope plating**
- 4 **Shell envelope framing**
- 5 **Single and double bottom structure**
- 6 **After peak structure**
- 7 **Sternframes and appendages**

■ Section 1 General

1.1 Application

1.1.1 This Chapter applies to all types of ship covered by *Pt 4 Ship Structures (Ship Types)*, except where specifically stated otherwise.

1.1.2 The requirements given are those specific to aft ends and relate to structure situated in the region aft of 0,3L from the after perpendicular.

1.1.3 Requirements for cargo space structure within this region not dealt with in this Chapter are to be as detailed in the relevant Chapter of *Pt 4 Ship Structures (Ship Types)* for the particular ship type.

1.1.4 The requirements in this Chapter are not applicable to Double Hull Oil Tankers or Bulk Carriers with a **CSR** notation. See *Pt 1, Ch 2, 2.3 Class notations (hull)*.

1.2 Structural configuration

1.2.1 The Rules provide for both longitudinal and transverse framing systems.

1.2.2 In the case of container ships and open type ships additional requirements may apply as detailed in *Pt 4, Ch 8 Container Ships*.

1.3 Structural continuity

1.3.1 Suitable scarfing arrangements are to be made to ensure continuity of strength and the avoidance of abrupt structural changes.

1.3.2 Where longitudinal framing terminates and is replaced by a transverse system, adequate arrangements are to be made to avoid an abrupt changeover. Where a poop is fitted extending forward of 0,15L from the A.P., longitudinal framing at the upper deck and topsides is generally to be continued aft of the forward bulkhead of this superstructure. In bulk carriers and oil tankers (see *Pt 3, Ch 6, 1.1 Application 1.1.4*) the longitudinal framing at the upper deck is to be maintained over the cargo space region and continued over the aft end region.

1.3.3 In oil tankers (see *Pt 3, Ch 6, 1.1 Application 1.1.4*) with machinery aft, continuity of the longitudinal bulkheads is to be maintained as far as is practicable into the machinery space, and suitable taper brackets are to be fitted at their ends.

1.3.4 In bulk carriers (see *Pt 3, Ch 6, 1.1 Application 1.1.4*) with machinery aft, continuity of the topside tank and double bottom hopper tank structure is to be maintained over the cargo space region and as far as is practicable continued into the machinery space, and suitable taper brackets are to be arranged at their ends. Also a vertical taper bracket in line with the vertical strake of the topside tank is to be fitted at the forward side of the aft bulkhead of the cargo space region. Where the topside tank and double bottom hopper tank structures terminate at the cargo space aft bulkhead, the vertical strake of the topside tank is to be arranged with an integral taper bracket and continued through the bulkhead into the machinery space for a distance of 0,2B, and the ends of the hopper and topside structures are to be arranged with suitable taper brackets. In addition, in way of the cargo

space aft bulkhead, a girder or intercostal bulb plate stiffeners (fitted between and connected to the bulkhead vertical stiffeners), are to be arranged on the aft side in line with the sloped bulkheads of the topside and hopper tanks clear of the taper brackets.

1.3.5 In container or similar ships having continuous side tanks or double skin construction in way of the cargo spaces, the longitudinal bulkheads are to be continued as far aft as is practicable and are to be suitably tapered at their ends. Where, due to the ship's form, such bulkheads are stepped, suitable scarfing is to be arranged.

1.4 Symbols and definitions

1.4.1 The following symbols and definitions are applicable to this Chapter unless otherwise stated:

L, B, D, T = as defined in *Pt 3, Ch 1, 6.1 Principal particulars*

k_L, k = higher tensile steel factor as defined in *Pt 3, Ch 2, 1.2 Steel*

l = overall length of stiffening member, in metres, see *Pt 3, Ch 3, 3.3 Determination of span point*

l_e = effective length of stiffening member, in metres, see *Pt 3, Ch 3, 3.3 Determination of span point*

s = spacing of secondary stiffeners, in mm

t = thickness of plating, in mm

S = spacing, or mean spacing, of primary members, in metres

Z = section modulus of stiffening member, in cm^3 , see *Pt 3, Ch 3, 3.2 Geometric properties of section*

ρ = relative density (specific gravity) of liquid carried in a tank and is to be taken not less than 1,025

I = inertia of stiffening member, in cm^4 , see *Pt 3, Ch 3, 3.2 Geometric properties of section*.

1.4.2 For the purpose of this Chapter, the after perpendicular, A.P., is defined as the after limit of the Rule length L .

■ Section 2 Deck structure

2.1 General

2.1.1 Where the upper deck is longitudinally framed outside the line of openings in the midship region, this system of framing is to be carried as far aft as possible. See also *Pt 4, Ch 9, 1.3 Class notation and applicable Rules for CSR Double Hull Oil Tankers*.

2.2 Deck plating

2.2.1 The thickness of strength/weather deck plating is to comply with the requirements of *Table 6.2.1 Strength/weather deck plating aft (excluding poop deck)*.

2.2.2 The thickness of lower deck plating is to comply with the requirements of *Table 6.2.2 Lower deck plating aft*.

2.2.3 The taper thickness of the strength deck stringer plate is to be increased by 20 per cent at the ends of a poop or bridge where the end bulkhead is situated forward of $0,25L$ from the A.P. No increase is required where the end bulkhead lies aft of $0,2L$ from the A.P. The increase at intermediate positions is to be determined by interpolation.

2.2.4 The deck plating thickness and supporting structure are to be suitably reinforced in way of deck machinery, and in way of cranes, masts or derrick posts.

2.2.5 Where long, wide hatchways are arranged at lower decks it may be necessary to increase the deck plating thickness to ensure effective support for side framing.

2.3 Deck stiffening

2.3.1 The scantlings of strength/weather deck longitudinals are to comply with the requirements of *Table 6.2.3 Strength/weather deck longitudinals aft*.

2.3.2 The scantlings of cargo and accommodation deck longitudinals are to comply with the requirements given in *Table 1.4.4 Cargo and accommodation deck longitudinals*.

2.3.3 End connections of longitudinals to bulkheads are to provide adequate fixity, lateral support and so far as practicable, direct continuity of longitudinal strength.

2.3.4 The scantlings of weather deck beams are to comply with the midship requirements for the particular ship type.

2.3.5 The scantlings of lower deck beams are to comply with the requirements of *Table 1.4.5 Strength/weather, cargo and accommodation deck beams in Pt 4, Ch 1 General Cargo Ships*.

2.3.6 End connections of beams are to be in accordance with the requirements of *Pt 3, Ch 10, 3 Secondary member end connections*.

Table 6.2.1 Strength/weather deck plating aft (excluding poop deck)

Symbols	Location	Thickness, in mm
<p>L, s, S, k, ρ as defined in <i>Pt 3, Ch 6, 1.4 Symbols and definitions 1.4.1</i></p> <p>$f = 1,1 - \frac{s}{2500S}$ but is to be taken not greater than 1,0</p>	(1) Aft of 0,075L from the A.P.	$t = (5,5 + 0,02L)\sqrt{\frac{ks_1}{s_b}}$
<p>h_4 = tank head, in metres, as defined in <i>Pt 3, Ch 3, 5 Design loading</i></p> <p>s_b = standard frame spacing as follows:</p>	(2) Between 0,075L and 0,15L from the A.P.	<p>The greater of the following:</p> <p>(a) $t = (5,5 + 0,02L)\sqrt{\frac{ks_1}{s_b}}$</p> <p>(b) the taper thickness, see Notes 1, 2 and 3</p> <p>(c) for oil tankers, the thickness is also to be in accordance with <i>Pt 4, Ch 9, 4.3 Deck plating 4.3.3</i></p>
<p>Aft of 0,15L from the A.P.:</p> <p>$s_b = \left(510 + \frac{L}{0,6}\right)$ mm or 850 mm,</p>	(3) Forward of 0,15L from the A.P.	The taper thickness, see Notes 1, 2 and 3, or as (2)(c) whichever is the greater
<p>whichever is the lesser</p> <p>$s_1 = s$, but is to be taken not less than s_b</p>	(4) Inside poop extending forward of 0,15L	As for a lower deck, see Note 4
	(5) In way of the crown of a tank	<p>$t = 0,004sf\sqrt{\frac{rkh_4}{1,025}} + 3,5$</p> <p>or (1) to (4) as applicable, whichever is the greater but not less than 7,5 mm where $L \geq 90$ m, or 6,5 mm where $L < 90$ m</p>

Note 1. The taper thickness is to be determined from *Table 3.2.1 Taper requirements for hull envelope* in Chapter 3.

Note 2. For taper area requirements, see *Table 3.2.1 Taper requirements for hull envelope* in Chapter 3.

Note 3. For thickness of upper deck plating in way of the cargo tanks of oil tankers or ore carriers, see also *Pt 4, Ch 9 Double Hull Oil Tankers, Pt 4, Ch 10 Single Hull Oil Tankers* or *Pt 4, Ch 11 Ore Carriers*.

Note 4. The exposed weather deck taper thickness is to extend into a poop or bridge for at least one-third of the breadth of the ship from the superstructure end bulkhead.

Note 5. The taper requirements from *Table 3.2.1 Taper requirements for hull envelope* in *Pt 3, Ch 3 Structural Design* do not apply to container ships or open ship types, see *Pt 3, Ch 4, 2.3 Open type ships*, where the requirements of *Pt 4, Ch 8, 3.2 Longitudinal strength* are applicable, nor to fast cargo ships where the requirements of *Pt 4, Ch 1, 3 Longitudinal strength* are applicable. See also *Pt 3, Ch 4, 5 Hull bending strength* for hull section modulus requirement away from the midship area.

Table 6.2.2 Lower deck plating aft

Symbols	Location	Thickness, in mm
<p>L, s, S, k, ρ as defined in Pt 3, Ch 6, 1.4 Symbols and definitions 1.4.1</p> <p>b = breadth of increased plating, in mm</p> <p>f = $1,1 - \frac{s}{2500S}$ but is to be taken not greater than 1,0</p> <p>h_4 = tank head, in metres, as defined in Pt 3, Ch 3, 5 Design loading</p> <p>K_2 = 2,5 mm at bottom of tank or 3,5 mm at crown of tank</p> <p>s_1 = s, but is to be taken not less than $\left(470 + \frac{L_1}{0,6}\right)$ mm</p> <p>A_f = girder face area, in cm^2</p> <p>L_1 = L, but need not be taken greater than 190 mm</p>	(1) Aft of 0,075L from the A.P.	$t = 0,01s_1\sqrt{k}$ but not less than 6,5 mm
	(2) Forward of 0,075L from the A.P., inside line of openings	$t = 0,01s_1\sqrt{k}$ but not less than 6,5 mm
	(3) Forward of 0,075L from the A.P., outside line of openings	As determined by a taper line from the midship thickness to the end thickness given by (1)
	(4) In way of the crown or bottom of a tank	$t = 0,004sf\sqrt{\frac{rkh_4}{1,025} + K_2}$ or (1), (2) or (3) as applicable, whichever is the greater but not less than 7,5 mm where $L \geq 90$ m, or 6,5 mm where $L < 90$ m
	(5) Plating forming upper flange of underdeck girders	Clear of cargo hatches $t = \sqrt{\frac{A_f}{1,8k}}$ In way of hatch side girders $t = 1,1\sqrt{\frac{A_f}{1,8k}}$
Note Where the deck loading exceeds 43,2 kN/m ² , (4,4 tonne-f/m ²), the thickness of plating will be specially considered. This is equivalent to a 'tween deck height of 6,1 m in association with the standard stowage rate of 1,39 m ³ /tonne.	Minimum breadth	$b = 760$ mm

Table 6.2.3 Strength/weather deck longitudinals aft

Location	Modulus, in cm ³	Inertia, in cm ⁴
(1) Aft of 0,075L from the A.P.	The greater of the following: (a) $Z = sk(400h_1 + 0,005(l_e L_1)^2) \times 10^{-4}$ (b) $Z = 0,0074skh_1 l_e^2$	—
(2) Forward of 0,075L from the A.P., inside line of openings	As (1)	—

(3) Forward of 0,075L from the A.P., outside line of openings	As determined from <i>Table 3.2.1 Taper requirements for hull envelope</i> in Chapter 3, see Note 1 For oil tankers (see <i>Pt 3, Ch 6, 1.1 Application 1.1.4</i>) and dry cargo ships the end modulus for taper at 0,075L from the A.P. is to be derived from <i>Table 5.2.3 Strength/weather deck longitudinals forward</i> item (2)	—
(4) In way of the crown of a tank	$Z = \frac{0,0113 r s k h_4 l^2}{b} e$ or as (1) to (3) as applicable, whichever is the greater	$l = \frac{2,3}{k} l_e Z$
Symbols		
<p>L, s, k_L, k, ρ as defined in <i>Pt 3, Ch 6, 1.4 Symbols and definitions 1.4.1</i></p> <p>$b = 1,4$ for rolled or built sections $= 1,6$ for flat bars</p> <p>$d_w =$ web depth of longitudinal, in mm</p> <p>$h_1 =$ weather head, in metres, as defined in <i>Pt 3, Ch 3, 5 Design loading</i></p> <p>$h_4 =$ tank head, in metres, as defined in <i>Pt 3, Ch 3, 5 Design loading</i></p> <p>$l_e =$ as defined in <i>Pt 3, Ch 6, 1.4 Symbols and definitions 1.4.1</i>, but is to be taken not less than 1,5 m</p> <p>$L_1 = L$ but need not be taken greater than 190 m</p>		
<p>Note 1. For taper area requirements, see <i>Table 3.2.1</i> in Chapter 3.</p> <p>Note 2. Where weather decks are intended to carry deck cargo and the loading is in excess of 8,5 kN/m² (0,865 tonne-f/m²) the scantlings of longitudinals are also to comply with the requirements for location (1) in <i>Table 1.4.4 Cargo and accommodation deck longitudinals</i> using the equivalent design head, for specified cargo loadings, for weather decks given in <i>Table 3.5.1 Design heads and permissible cargo loadings</i>.</p> <p>Note 3. For the scantlings of deck longitudinals aft in way of the cargo tanks of oil tankers (see <i>Pt 3, Ch 6, 1.1 Application 1.1.4</i>) or ore carriers, see also <i>Pt 4, Ch 9 Double Hull Oil Tankers, Pt 4, Ch 10 Single Hull Oil Tankers</i> or <i>Pt 4, Ch 11 Ore Carriers</i> as applicable.</p> <p>Note 4. The thickness of flat bar longitudinals, situated outside the line of openings is to be not less than the following:</p> <p>Note (a) $t = \frac{d_w}{18\sqrt{k_L}}$ mm where longitudinal continuous through bulkhead</p> <p>Note (b) $t = \frac{d_w}{15\sqrt{k_L}}$ mm where longitudinal cut at bulkhead</p> <p>Note 5. The web depth of longitudinal, d_w, to be not less than 60 mm.</p> <p>Note 6. The taper requirements from <i>Table 3.2.1 Taper requirements for hull envelope</i> in <i>Pt 3, Ch 3 Structural Design</i> do not apply to container ships or open ship types, see <i>Pt 3, Ch 4, 2.3 Open type ships</i>, where the requirements of <i>Pt 4, Ch 8, 3.2 Longitudinal strength</i> are applicable, nor to fast cargo ships where the requirements of <i>Pt 4, Ch 1, 3 Longitudinal strength</i> are applicable. See also <i>Pt 3, Ch 4, 5 Hull bending strength</i> for hull section modulus requirement away from the midship area.</p>		

2.4 Deck supporting structure

2.4.1 The arrangements and scantlings of supporting structure are generally to be in accordance with the requirements given in *Pt 4, Ch 1, 4 Deck structure* except as required by *Pt 3, Ch 6, 2.4 Deck supporting structure 2.4.2* to *Pt 3, Ch 6, 2.4 Deck supporting structure 2.4.4*.

2.4.2 At upper and lower decks above the after peak, deep beams are generally to be fitted in way of web frames. Deck girders are generally to be spaced not more than 3,0 m apart.

2.4.3 Primary structure in the topside tanks of bulk carriers is to comply with the requirements of *Pt 4, Ch 7, 7 Topside tank structure*.

2.4.4 Primary structure in the cargo tanks of oil tankers, or ore carriers, is to be determined from *Pt 4, Ch 9 Double Hull Oil Tankers, Pt 4, Ch 10 Single Hull Oil Tankers* or *Pt 4, Ch 11 Ore Carriers*, as applicable.

2.5 Deck openings

2.5.1 In dry cargo ships, the requirements for deck openings given in *Pt 4, Ch 1, 4 Deck structure* are generally applicable throughout the aft region except that aft of 0,25L from the A.P.:

- (a) The radii or dimensions of the corners of main cargo hatchway openings of the strength deck are to be in accordance with the requirements of *Pt 4, Ch 1, 4.5 Deck openings*. The thickness of the insert plates, where required, is not to be less than 20 per cent greater than the adjacent deck thickness outside the line of openings, with a minimum increase of 3 mm.
- (b) Insert plates will be required at lower decks in way of any rapid change in hull form to compensate for loss of deck cross-sectional area. Otherwise, insert plates will not normally be required.
- (c) Compensation and edge reinforcement for openings outside the line of main hatchways will be considered, bearing in mind their position, the deck arrangements and the type of ship concerned.

2.5.2 For deck openings in way of cargo tanks in oil tankers and ore carriers, see also *Pt 4, Ch 9 Double Hull Oil Tankers, Pt 4, Ch 10 Single Hull Oil Tankers* or *Pt 4, Ch 11 Ore Carriers*, as applicable. For main cargo hatchway openings on bulk carriers and container ships, see also *Pt 4, Ch 7 Bulk Carriers* and *Pt 4, Ch 8 Container Ships*, as applicable.

■ Section 3

Shell envelope plating

3.1 General

3.1.1 Where the shell is longitudinally framed in the midship region, this system of framing is to be carried as far aft as practicable.

3.2 Keel

3.2.1 The scantlings of bar keels at the aft end are to be the same as in the midship region as required by *Pt 4, Ch 1, 5 Shell envelope plating*.

3.2.2 The thickness and width of plate keels in the aft region are to be the same as required in the midship region for the particular type of ship concerned, see *Pt 4 Ship Structures (Ship Types)*.

3.3 Bottom shell and bilge

3.3.1 The thickness of bottom shell and bilge plating in the aft region is to comply with the requirements of *Table 6.3.1 Shell plating aft*.

3.3.2 Where the bottom is transversely framed and there are large flat areas of shell plating, the buckling stability of the plating will be specially considered, and increased plate thickness or additional stiffening may be required, see also *Pt 3, Ch 6, 5.2 Single bottoms – Transverse framing 5.2.3*.

3.3.3 Where longitudinals are omitted in way of radiused bilge plating amidships, the plating thickness aft will be considered in relation to the support derived from the hull form and internal stiffening arrangements.

3.4 Side shell and sheerstrake

3.4.1 The thickness of side shell and sheerstrake plating in the aft region is to be not less than the values given in *Table 6.3.1 Shell plating aft*, but may be required to be increased locally on account of high shear forces, in accordance with *Pt 3, Ch 4, 6.5 Permissible still water shear force*.

3.4.2 Increased shell plate thickness may be required where the panting stringers required by *Pt 3, Ch 6, 4.4 Panting stringers in way of transverse framing 4.4.1* are omitted. The extent and amount of the increase will be specially considered.

3.4.3 The thickness of shell plating is to be increased locally in way of the sternframe, propeller brackets or rudder horn. The increased plate thickness is to be not less than 50 per cent greater than the basic shell end thickness.

3.4.4 The sheerstrake thickness is to be increased by 20 per cent at the ends of a bridge superstructure extending out to the ship's side, irrespective of position. Similar strengthening is to be fitted in way of the end of a poop if this occurs at a position forward of 0,25L from the A.P. No increase is required if the poop end bulkhead lies aft of 0,2L from the A.P. The increase at intermediate positions of end bulkhead is to be obtained by interpolation.

3.5 Shell openings

3.5.1 In general, compensation will not be required for holes in the sheerstrake which are clear of the gunwale, or for any deck openings situated outside the line of main hatchways and whose depth does not exceed 20 per cent of the depth of the sheerstrake or 380 mm, whichever is the lesser. Openings are not to be cut in a rounded gunwale. Cargo door openings are to have well rounded corners, and the proposed compensation for the door openings will be individually considered.

Table 6.3.1 Shell plating aft

Location	Thickness, in mm	NOTES
(1) Bottom shell and bilge, see Notes 4 and 5: (a) Aft of 0,075L from the A.P. (b) Between 0,075L and 0,15L from the A.P., see Note 6 (c) Forward of 0,15L from the A.P., see Note 6	$t = (6,5 + 0,033L) \sqrt{\frac{ks_1}{s_b}}$ (see Note 1) As (1)(a) or the taper thickness, whichever is the greater, see Note 2 The taper thickness, see Note 2	Note 1. For ships where $L \leq 70$ m this thickness may be reduced by 1 mm, but it is to be not less than 6 mm. Note 2. The taper thickness is to be determined from Table 3.2.1 Taper requirements for hull envelope, see Note 7. Note 3. For thickness of shell plating in way of the cargo tanks of oil tankers or ore carriers, see also Pt 4, Ch 9 Double Hull Oil Tankers, Pt 4, Ch 10 Single Hull Oil Tankers or Pt 4, Ch 11 Ore Carriers, as applicable.
(2) Side shell, see Notes 4 and 5: (a) Aft of 0,075L from the A.P. (b) Between 0,075L and 0,15L from the A.P., see also Pt 3, Ch 6, 3.4 Side shell and sheerstrake 3.4.2 (c) Forward of 0,15L from the A.P.	$t = (6,5 + 0,033L) \sqrt{\frac{ks_1}{s_b}}$ (see Note 1) As (2)(a) or the taper thickness, whichever is the greater, see Note 2 The taper thickness, see Note 2	Note 4. In offshore supply ships the thickness of side shell is to be not less than 9 mm. Note 5. For trawlers and fishing vessels see Pt 4, Ch 6, 5 Shell envelope plating. Note 6. For oil tankers the thickness is also to be in accordance with Pt 4, Ch 9, 4.3 Deck plating 4.3.3
(3) Sheerstrake, see Notes 4 and 5 (a) Aft of 0,075L from the A.P.: where $\frac{T}{D} > 0,7$ where $\frac{T}{D} \leq 0,7$ (b) Between 0,075L and 0,15L from the A.P., see Note 6 (c) Forward of 0,15L from the A.P., see Note 6	As (2)(a) for side shell As (4) for a poop As (3)(a) or as determined from Table 3.2.1 Taper requirements for hull envelope The taper thickness, see Note 2	Note 7. The taper requirements from Table 3.2.1 Taper requirements for hull envelope in Pt 3, Ch 3 Structural Design do not apply to container ships or open ship types, see Pt 3, Ch 4, 2.3 Open type ships, where the requirements of Pt 4, Ch 8, 3.2 Longitudinal strength are applicable, nor to fast cargo ships where the requirements of Pt 4, Ch 1, 3 Longitudinal strength are applicable. See also Pt 3, Ch 4, 5 Hull bending strength for hull section modulus requirement away from the midship area.
(4) Poop, see Notes 4 and 5	$t = (6,5 + 0,017L) \sqrt{\frac{ks_1}{s_b}}$	
Symbols		

L, B, D, T, s, k as defined in Pt 3, Ch 6, 1.4 Symbols and definitions 1.4.1

$s_1 = s$ but to be taken as not less than s_b

$s_b =$ standard frame spacing, in mm, as follows:

Region	Bottom shell s_b	Side shell s_b
Aft of 0,05L from the A.P.	$\left(470 + \frac{L}{0,6}\right)$ or 600*	below the deck next above the load waterline
	or $\left(470 + \frac{L}{0,6}\right)$ or 700*	above the deck next above the load waterline
Between 0,05L and 0,15L from the A.P.	$\left(510 + \frac{L}{0,6}\right)$ or 850*	

*whichever is the lesser

3.5.2 Sea inlet and other openings are to have well rounded corners and so far as possible, should be kept clear of the bilge radius. The thickness of sea inlet box plating is generally to be the same as the adjacent shell. It is not, however, to be less than 12,5 mm, and need not exceed 25 mm.

■ *Section 4*
Shell envelope framing

4.1 General

4.1.1 Requirements are given in this Section for both longitudinal and transverse framing systems. Where longitudinal framing is adopted in the midship region, it is to be carried as far aft as practicable.

4.1.2 End connections of longitudinals to bulkheads are to provide adequate fixity, lateral support and, so far as practicable, direct continuity of longitudinal strength, *see also Pt 3, Ch 10, 3 Secondary member end connections*. Where L exceeds 215 m, the bottom longitudinals are to be continuous in way of both watertight and non-watertight floors, but alternative arrangements will be considered. Higher tensile steel longitudinals within 10 per cent of the ship's depth at the bottom and deck are to be continuous irrespective of the ship length.

4.1.3 Stiffeners and brackets on side transverses, where fitted on one side and connected to higher tensile steel longitudinals between the base line and 0,8D above the base line, are to have their heels well radiused to reduce stress concentrations. Where a symmetrical arrangement is fitted, i.e. bracket or stiffening on both sides, and it is connected to higher tensile steel longitudinals, the toes of the stiffeners or brackets are to be well radiused. Alternative arrangements will be considered if supported by appropriate direct calculations.

4.1.4 Where higher tensile steel side longitudinals pass through transverse bulkheads in the cargo area, well radiused brackets of the same material are to be fitted on both the fore and aft side of the connection between the upper turn of bilge and 0,8D above the base line. Particular attention is to be given to ensuring the alignment of these brackets. Alternative arrangements will be considered if supported by appropriate direct calculations.

4.1.5 For ships intended to load or unload while aground, *see Pt 3, Ch 9, 7 Bottom strengthening for loading and unloading aground*.

4.2 Shell longitudinals

4.2.1 The scantlings of bottom and side shell longitudinals in the aft region are to comply with the requirements given in *Table 6.4.1 Shell framing (longitudinal) aft*.

4.3 Shell framing

4.3.1 The scantlings of side frames in the aft region are to comply with the requirements given in *Table 6.4.2 Shell framing (transverse) aft*.

Table 6.4.1 Shell framing (longitudinal) aft

Location	Modulus, in cm ³
(1) Side longitudinals in poop	$Z = 0,0065sk l_e^2(0,6 + 0,167D_2)$
(2) Side longitudinals in way of dry spaces including double skin construction: (a) Aft of the after peak bulkhead (b) Between the after peak bulkhead and 0,2L from the A.P. (c) Forward of 0,2L from the A.P.	$Z = 0,0085skh_{T1} l_e^2 F_s$ but not to be less than as required by (1) $Z = 0,007skh_{T1} l_e^2 F_s$ or as required in the midship region for the particular type of ship concerned, whichever is the greater As required in the midship region for the particular type of ship concerned
(3) Side longitudinals in way of double skin tanks or deep tanks	The greater of the following: (a) Z as from (2) (b) As required by <i>Pt 4, Ch 1, 9 Bulkheads</i> for deep tanks
(4) Bottom and bilge longitudinals	As required in the midship region for the particular type of ship concerned
Symbols	
<p><i>L, D, T, s, k</i>, as defined in <i>Pt 3, Ch 6, 1.4 Symbols and definitions 1.4.1</i></p> <p><i>l_e</i> as defined in <i>Pt 3, Ch 6, 1.4 Symbols and definitions 1.4.1</i>, but is to be taken not less than 1,5m</p> <p style="text-align: center;">$D_2 = D_1$ but need not be taken greater than 20 m</p> <p style="text-align: center;">$L_1 = L$ but need not be taken greater than 190 m</p> <p><i>F_s</i> is a fatigue factor to be taken as follows:</p> <p>(a) For built sections and rolled angle bars</p> $F_s = \frac{1,1}{k} \left[1 - \frac{2b_{f1}}{b_f}(1 - k) \right] \text{ at } 0,6D_1 \text{ above the base line}$ <p style="text-align: center;">= 1,0 at <i>D₁</i> and above, and <i>F_{sb}</i> at the base line intermediate values by linear interpolation</p> <p><i>F_{sb}</i> is a fatigue factor for bottom longitudinals</p> <p style="text-align: center;">= 0,5 (1 + <i>F_s</i> at 0,6<i>D₁</i>)</p> <p>(b) For flat bars and bulb plates $\frac{b_{f1}}{b_f}$ may be taken as 0,5</p> <p>where</p> <p>b_{f1} = the minimum distance, in mm, from the edge of the face plate of the side longitudinal under consideration to the centre of the web plate, see <i>Figure 9.5.1 Definition of b_f and b_{f1}</i></p>	

b_f = the width of the face plate, in mm, of the side longitudinal under consideration, see Figure 9.5.1 Definition of b_f and b_{f1}

D_1 = D but need not exceed $T + H_b$, in metres, where H_b is the minimum bow height, in metres, obtained from Pt 3, Ch 1, 6.1 Principal particulars 6.1.11

T_1 = T but not to be taken less than $0,65D_1$

h_{T1} = $f_w C_w \left(1 - \frac{h_6}{D_1 - T_1}\right) F_\lambda$, in metres, for longitudinals above the waterline at draught T_1 , where $f_w \left(1 - \frac{h_6}{D_1 - T_1}\right)$ is not to be less than 0,7
 = $\left[h_6 + f_w C_w \left(1 - \frac{h_6}{2T_1}\right) \right] F_\lambda$, in metres, for longitudinals below the waterline at draught T_1

where

f_w = 1,0 at 0,2L from A.P. and 1,32 at and aft of aft peak bulkhead. Intermediate positions by interpolation.

h_6 = vertical distance, in metres, from the waterline at draught T_1 , to the longitudinal under consideration

C_w = a wave head, in metres = $7,71 \times 10^{-2} L e^{-0,0044L}$

where

e = base of natural logarithm 2,7183

F_λ = 1,0 for $L \leq 200$ m
 = $[1,0 + 0,0023 (L - 200)]$ for $L > 200$ m

Note 1. Where struts are fitted midway between transverses in double skin construction, the modulus of the side longitudinals may be reduced by 50k per cent from that obtained for locations (2) and (3) as applicable.

Note 2. For modulus and area of side longitudinals in way of a machinery space, see Pt 3, Ch 7, 3.1 Secondary stiffening.

Table 6.4.2 Shell framing (transverse) aft

Location	Modulus, in cm ³	Inertia, in cm ⁴
(1) Frames in after peak spaces and lower 'tween decks over	$Z = 1,85s k T D_2 S_1 \times 10^{-3}$	$I = \frac{3,2}{k} S_1 Z$
(2) Frames in upper 'tween decks and poops aft of the after peak bulkhead, see Notes 1, 2 and 6	The greater of the following: (a) $Z = C s k h_{T1} H^2 \times 10^{-3}$ (b) $Z = 9,1s k D_1 \times 10^{-3}$	$I = \frac{3,2}{k} H Z$
(3) Main and 'tween deck frames (including poop) between the after peak bulkhead and 0,2L from the A.P., see Notes 1, 2 and 3	The greater of the following: (a) $Z = C s k h_{T1} H^2 \times 10^{-3}$ (b) $Z = 9,1s k D_1 \times 10^{-3}$	$I = \frac{3,2}{k} H Z$
(4) Main and 'tween deck frames elsewhere, see Notes 1, 2 and 3	As required in the midship region for the particular type of ship concerned	

(5) Panting stringers, see Note 4	<p>Web depth, d_w, same depth as frames</p> <p>Web thickness, $t = t_w$ as in Pt 3, Ch 10, 4.4 Geometric properties and proportions</p> <p>Face area, $A = k S_2 (H + 1) \text{ cm}^2$</p>
Symbols	
<p>L, D, T, s, k as defined in Pt 3, Ch 6, 1.4 Symbols and definitions 1.4.1</p> <p>$D_1 = D$ but need not exceed $T + H_b$, in metres, where H_b is the minimum bow height, in metres, obtained from Pt 3, Ch 1, 6.1 Principal particulars 6.1.11</p> <p>$D_2 = D_1$ but is to be taken not greater than 16 m nor less than 6 m</p> <p>$H = H_{MF}$ or H_{TF} as applicable, see Note 3</p> <p>H_{MF} = vertical framing depth, in metres, of main frames as shown in Figure 6.4.1 Framing depths but is not to be taken less than 3,5 m, see Note 5</p> <p>H_{TF} = vertical framing depth, in metres, of 'tween deck frames as shown in Figure 6.4.1 Framing depths, but is not to be taken less than 2,5 m</p> <p>S_1 = vertical spacing of peak stringers or height of lower 'tween deck above the peak, in metres, as applicable</p> <p>S_2 = vertical spacing of panting stringers, in metres</p> <p>C = end connection factor</p> <p>= 3,4 where two Rule standard brackets fitted</p> <p>= 3,4 (1,8 - 0,8 (l_a/l)) where one Rule standard bracket and one reduced bracket fitted</p> <p>= 3,4 (2,15 - 1,15(l_{amean}/l)) where two reduced brackets fitted</p> <p>= 6,1 where one Rule standard bracket fitted</p> <p>= 6,1 (1,2 - 0,2 (l_a/l)) where one reduced bracket fitted</p> <p>= 7,3 where no brackets fitted</p> <p>The requirements for frames where brackets larger than Rule standard are fitted will be specially considered</p> <p>l = length, in mm, as derived from Pt 3, Ch 10, 3.4 Scantlings of end brackets 3.4.1</p> <p>l_a = equivalent arm length, in mm, as derived from Pt 3, Ch 10, 3.4 Scantlings of end brackets 3.4.1</p> <p>l_{amean} = mean equivalent arm length, in mm, for both brackets</p> <p>$T_1 = T$ but not to be taken less than $0,65D_1$</p>	

$$\begin{aligned}
 h_{T1} &= \text{head, in metres, at mid-length of } H \\
 &= f_w C_w \left(1 - \frac{h_6}{D_1 - T_1} \right) F_\lambda, \text{ in metres for frames where the mid-length of frame is above the waterline, at draught } T_1 \\
 &\quad f_w \left(1 - \frac{h_6}{D_1 - T_1} \right) \text{ is not to be taken less than } 0,7 \\
 &= \left[h_6 + f_w C_w \left(1 - \frac{h_6}{2T_1} \right) \right] F_\lambda, \text{ in metres for frames where the mid-length of frame is below the waterline at draught } T_1
 \end{aligned}$$

where

$$f_w = 1,0 \text{ at } 0,2L \text{ from A.P. and } 1,32 \text{ at and aft of aft peak bulkhead. Intermediate positions by interpolation.}$$

$$h_6 = \text{vertical distance in metres from the waterline at draught } T_1 \text{ to the mid-length of } H$$

$$\begin{aligned}
 F_\lambda &= 1,0 \text{ for } L \leq 200 \text{ m} \\
 &= [1,0 + 0,0023 (L - 200)] \text{ for } L > 200 \text{ m}
 \end{aligned}$$

$$\begin{aligned}
 C_w &= \text{a wave head in metres} \\
 &= 7,71 \times 10^{-2} L e^{-0,0044 L}
 \end{aligned}$$

where e = base of natural logarithm 2,7183

- Note 1.** In fishing vessels the modulus of main and 'tween deck frames need not be greater than 80 % of that given in (2).
- Note 2.** In offshore supply ships the moduli of main and 'tween deck frames are to be 25 % greater than those given in (2), (3) and (4).
- Note 3.** Where frames are inclined at more than 15° to the vertical, H_{MF} or H_{TF} is to be measured along a chord between span points of the frame.
- Note 4.** Panting stringers are not required in tugs less than 46 m in length, see Pt 4, Ch 3, 4 *Panting and strengthening of bottom forward*.
- Note 5.** Where the frames are supported by fully effective horizontal stringers, these may be considered as decks for the purpose of determining H_{MF} .
- Note 6.** Except for main frames the modulus for these members need not exceed that derived from (1) using H_{TF} in place of S_1 .

4.3.2 The scantlings of main frames are normally to be based on Rule standard brackets at top and bottom, whilst the scantlings of 'tween deck frames are normally to be based on a Rule standard bracket at the top only.

4.3.3 End connections of transverse main and 'tween deck frames are to be in accordance with Pt 3, Ch 10, 3 *Secondary member end connections*. For bulk carriers (see Pt 3, Ch 6, 1.1 *Application 1.1.4*), the end connections of main frames in cargo holds are to be in accordance with Pt 4, Ch 7, 6.2 *Transverse stiffening 6.2.5 to Pt 4, Ch 7, 6.2 Transverse stiffening 6.2.12*.

4.4 Panting stringers in way of transverse framing

4.4.1 In deep 'tween decks above the after peak space, panting stringers having scantlings as given in Table 6.4.2 *Shell framing (transverse) aft* or increased shell plate thickness may be required, see also Pt 3, Ch 6, 3.4 *Side shell and sheerstrake 3.4.2*.

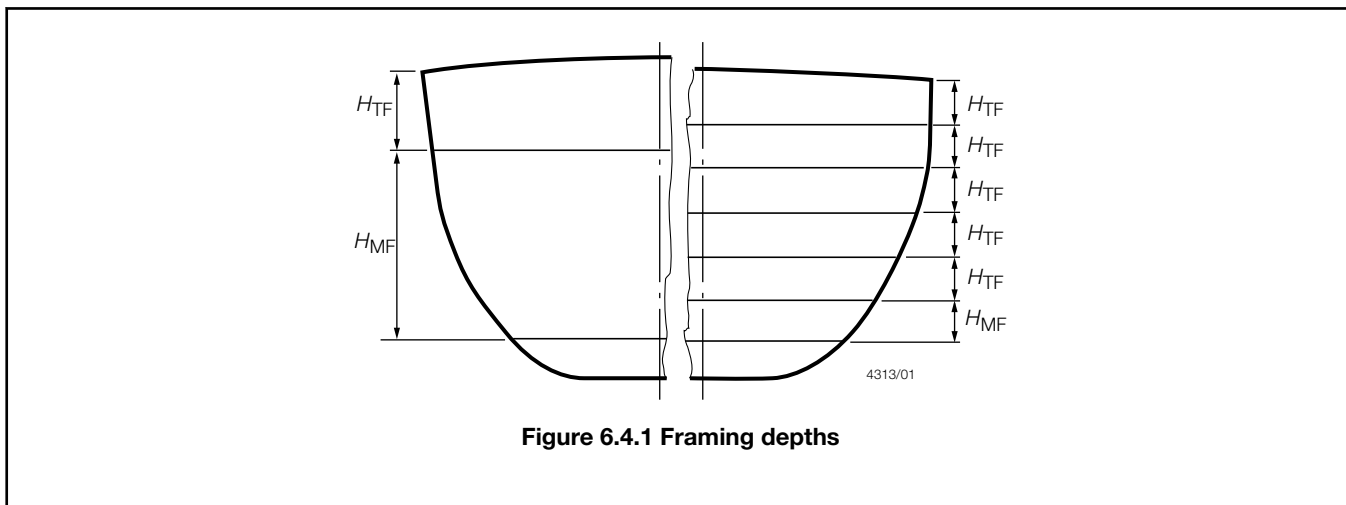

Figure 6.4.1 Framing depths

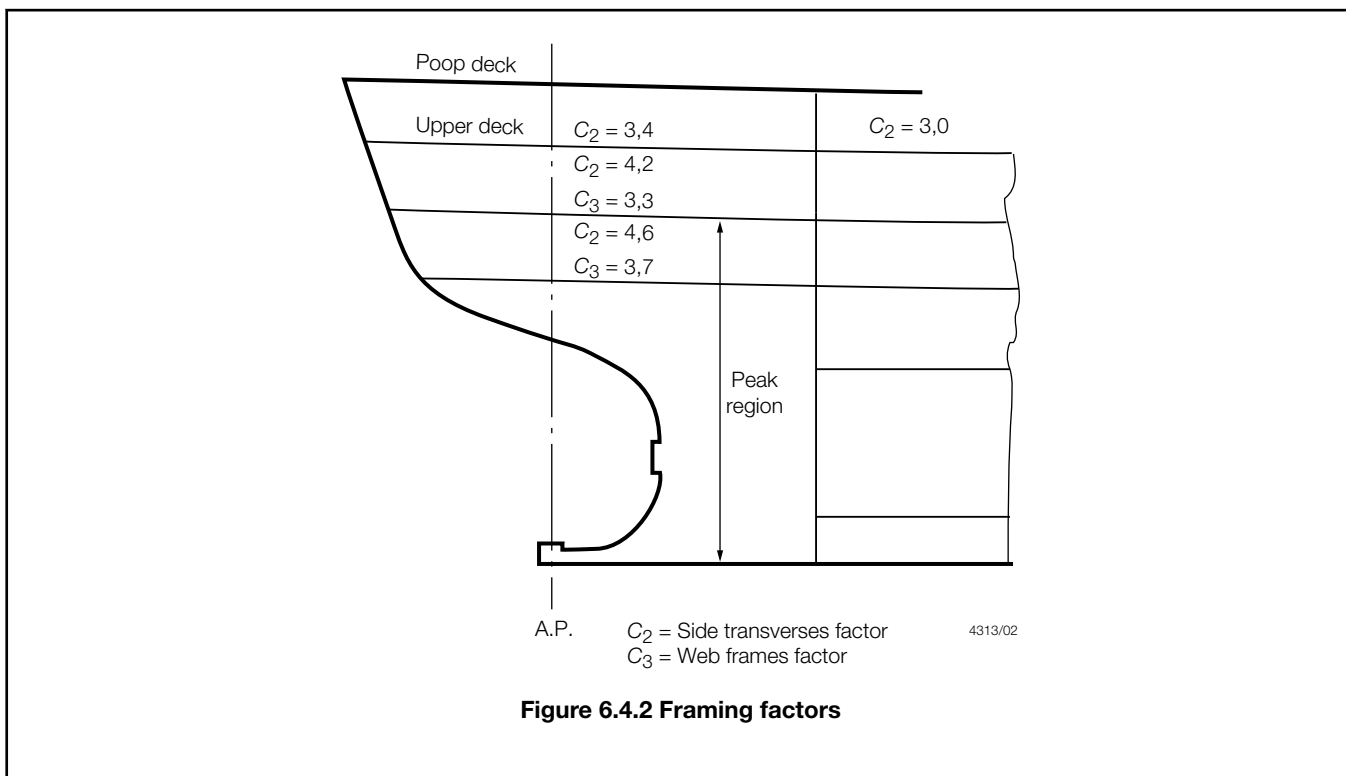

Figure 6.4.2 Framing factors

4.5 Primary structure at sides

4.5.1 Where the 'tween decks above an after peak space are transversely framed, web frames are to be fitted. Their spacing is generally not to exceed the values given in *Table 6.4.3 Spacing of side transverses and web frames aft*, and their scantlings are to be determined from *Table 6.4.4 Primary structure aft*.

4.5.2 Where longitudinal framing is arranged, the spacing of transverses is generally not to exceed the values given in *Table 6.4.3 Spacing of side transverses and web frames aft*, and their scantlings are to be determined from *Table 6.4.4 Primary structure aft*.

4.5.3 Where the shape of the after sections is such that there are large sloped flat areas, particularly in the vicinity of the propellers, additional primary supports for the secondary stiffening may be required. Their extent and scantlings will be specially considered.

4.5.4 The web thickness, stiffening arrangements and connections of primary supporting members are to be in accordance with the requirements of Pt 3, Ch 10, 4 Construction details for primary members.

Table 6.4.3 Spacing of side transverses and web frames aft

Location	Maximum spacing	
	Web frames in association with transverse framing system	Side transverses in association with longitudinal framing system
(1) Aft of the after peak bulkhead	4 frame spaces	2,5 m where $L \leq 100$ m 3,5 m where $L \geq 300$ m Intermediate values by interpolation
(2) Elsewhere in way of dry cargo spaces or deep tanks, see Note	—	3,8 m where $L \leq 100$ m (0,006L + 3,2) m where $L > 100$ m
(3) In way of cargo tanks of oil tankers, chemical tankers or ore or oil carriers	—	3,6 m where $L \leq 180$ m 0,02L where $L > 180$ m

Note For the maximum spacing of transverses in dredgers, see Pt 4, Ch 12, 5 Shell envelope framing.

Table 6.4.4 Primary structure aft

Item and location	Modulus, in cm^3	Inertia, in cm^4
Longitudinal framing system		
(1) Side transverses in dry spaces aft of the after peak bulkhead, see Note 4:		—
(a) Lower space	$Z = 10 k S h_{T1} l_e^2$	
(b) 'Tween deck	$Z = C_2 k S T H_{TF} \sqrt{D}$	
(2) Side transverses in tanks aft of the after peak bulkhead, see Note 4:		$I = \frac{2,5}{k} l_e Z$
(a) Lower space	$Z = 11,7 \rho k S h_4 l_e^2$	
(b) 'Tween decks	$Z = 14,1 \rho k S h_4 l_e^2$ or as (1) above, whichever is the greater	
(3) Side transverses in dry spaces and deep tanks forward of the after peak bulkhead	As in Pt 4, Ch 1, 6 Shell envelope framing, see Notes 1 and 2	
Transverse framing system		
(4) Side stringers supported by webs in after peak dry space, see Note 3	$Z = 7,75 k S h_{T1} l_e^2$	—
(5) Side stringers supported by webs in after peak tank, see Note 3	$Z = 11,7 \rho k S h_4 l_e^2$ or as (4) above, whichever is the greater	$I = \frac{2,5}{k} l_e Z$

(6) Web frames supporting side stringers in after peak, see Note 3	<p>Z = to be determined from calculations based on the following assumptions:</p> <p>(a) Fixed ends (b) Point loadings from stringers (c) Head h_4 or h_{T1} as applicable (d) Bending stress $\frac{93,2}{k}$ N/mm² ($\frac{9,5}{k}$ kgf/mm²) (e) Shear stress $\frac{83,4}{k}$ N/mm² ($\frac{8,5}{k}$ kgf/mm²)</p>	<p>In deep tanks: $I = \frac{2,5}{k} l_e Z$</p>
(7) Web frames in 'tween decks aft of the after peak bulkhead not supporting side stringers	<p>$Z = C_3 k S T H_{TF} \sqrt{D}$</p>	<p>—</p>
(8) Side stringers and web frames in dry spaces and deep tanks forward of the after peak bulkhead	<p>As in Pt 4, Ch 1, 6 Shell envelope framing, see Notes 1 and 2</p>	
<p>Symbols</p>		
<p>D, T, S, l_e, k, ρ as defined in Pt 3, Ch 6, 1.4 Symbols and definitions 1.4.1</p> <p>C_2, C_3 = factors obtained from Figure 6.4.2 Framing factors</p> <p>h_4 = tank head, in metres, as defined in Pt 3, Ch 3, 5 Design loading</p> <p>h_{T1} = head, in metres, at mid-length of span</p> <p>= $f_W C_W \left(1 - \frac{h_6}{D_1 - T_1}\right) F_\lambda$, in metres where the mid-length of span is above the waterline at draught T_1</p> <p>where $f_W \left(1 - \frac{h_6}{D_1 - T_1}\right)$ is not to be taken less than 0,7</p> <p>= $\left[h_6 + f_W C_W \left(1 - \frac{h_6}{2T_1}\right)\right] F_\lambda$, in metres where the mid-length of span is below the waterline at draught T_1</p> <p>where</p> <p>f_W = 1,0 at 0,2L from A.P. and 1,32 at and aft of aft peak bulkhead. Intermediate positions by interpolation</p> <p>h_6 = vertical distance, in metres, from the waterline at draught T_1 to the mid-length of span</p> <p>F_λ = 1,0 for $L \leq 200$ m = $[1,0 + 0,023 (L - 200)]$ for $L > 200$ m</p> <p>C_W = a wave head, in metres = $7,71 \times 10^{-2} L e^{-0,0044 L}$ = where e=base of natural logarithms 2,7183</p> <p>D_1 = D but need not be taken greater than $T + H_b$, in metres, where H_b is the minimum bow height, in metres, obtained from Pt 3, Ch 1, 6.1 Principal particulars 6.1.11</p> <p>T_1 = T but not to be taken less than $0,65D_1$</p>		

H_{TF} = vertical height of 'tween decks, in metres, as shown in *Figure 6.4.1 Framing depths*

Note 1. In way of the cargo tanks or fuel oil tanks of oil tankers or ore carriers, the scantlings of primary structure are to comply with the requirements of *Pt 4, Ch 9 Double Hull Oil Tankers*, *Pt 4, Ch 10 Single Hull Oil Tankers* or *Pt 4, Ch 11 Ore Carriers*, as appropriate.

Note 2. For bulk carriers, see *Pt 4, Ch 7, 6 Shell envelope framing*

Note 3. For stringers and webs in after peaks, see also *Pt 3, Ch 6, 6.2 Side structure – Transverse framing*.

Note 4. The web depth of side transverses aft of the after peak bulkhead is to be not less than 2,5 times the depth of the longitudinals supported. The web depth of stringers is to be not less than 2,2 times the depth of frames supported.

■ Section 5 Single and double bottom structure

5.1 General

5.1.1 For dry cargo ships exceeding 120 m in length, and for all ships which are strengthened for heavy cargoes, longitudinal framing is, in general, to be adopted, see also *Pt 4, Ch 9, 1.3 Class notation and applicable Rules for CSR Double Hull Oil Tankers*.

5.1.2 For ships having the notation 'strengthened for heavy cargoes', the requirements of *Pt 4, Ch 7, 8 Double bottom structure* are also to be complied with, as applicable.

5.1.3 For ships intended to load or unload while aground, see *Pt 3, Ch 9, 7 Bottom strengthening for loading and unloading aground*.

5.1.4 Provision is to be made for the free passage of water and/or air from all parts of single or double bottoms to the bilge or tank suction, account being taken of the pumping rates required.

5.1.5 For passenger ships, see *Pt 4, Ch 2, 6 Double bottom*.

5.2 Single bottoms – Transverse framing

5.2.1 In after peak spaces, floors are to be arranged at every frame. For details and scantlings, see *Pt 3, Ch 6, 6.1 Bottom structure*.

5.2.2 In way of dry cargo spaces aft, the arrangement and scantlings of transversely framed single bottoms are to be generally as required in the midship region, as given in *Pt 4, Ch 1, 7 Single bottom structure*, except that the thickness of the centreline girder may be tapered from the midship thickness at 0,3L from the A.P. to $t = (\sqrt{Lk} + 0,5)$ mm or 6 mm, whichever is the greater, at 0,075L from the A.P. In ships having considerable rise of floor towards the aft end, the depth of the floors may be required to be increased.

5.2.3 Where the shape of the after sections is such that there are large flat areas of shell plating, additional stiffening and/or increased shell plate thickness may be required, see *Pt 3, Ch 6, 3.3 Bottom shell and bilge*. The extent of this stiffening will be specially considered.

5.3 Single bottoms – Longitudinal framing

5.3.1 The scantlings and arrangement of longitudinally framed single bottoms in way of dry cargo spaces will be specially considered.

5.4 Double bottoms

5.4.1 The minimum depth of centre girder aft is generally to be the same as that required in the midship region by *Pt 4 Ship Structures (Ship Types)* for the particular type of ship concerned, but in ships with considerable rise of floor a greater depth may be required at the aft end to provide adequate access throughout the double bottom tank.

5.4.2 Where the height of the double bottom varies, this variation is generally to be made gradual by sloping the inner bottom over an adequate longitudinal extent. Knuckles in the plating are to be arranged close to plate floors. Otherwise, suitable scarfing arrangements are to be made.

5.4.3 For dry cargo ships, the arrangement and scantlings of girders, floors, inner bottom plating and inner bottom stiffening in the aft end region are to be determined from *Pt 4, Ch 1, 8 Double bottom structure*.

5.4.4 For double bottom construction in way of the cargo tanks of oil tankers or ore carriers, see also *Pt 4, Ch 9 Double Hull Oil Tankers, Pt 4, Ch 10 Single Hull Oil Tankers or Pt 4, Ch 11 Ore Carriers*, as appropriate.

■ **Section 6**
After peak structure

6.1 Bottom structure

6.1.1 Floors are to be arranged at every frame space and are to be carried to a suitable height, and at least to above the sterntube, where fitted. They are to have a thickness as determined from *Table 6.6.1 After peak structure* and are to be adequately stiffened. In way of a propeller post, rudder post or rudder horn, the floors are generally to be carried to the top of the space and are to be increased in thickness. The extent and amount of the increase will be specially considered, account being taken of the arrangements proposed.

6.2 Side structure – Transverse framing

6.2.1 Above the floors, transverse side framing is to be supported by one of the following arrangements:

- (a) Side stringers spaced not more than 2,5 m apart and supported by web frames. The upper ends of the web frames are to be supported under the tank top by suitable deep beams to form a ring structure.
- (b) Perforated flats spaced not more than 2,5 m apart. The area of perforations in each flat is to be not less than 10 per cent of the total area of the flat.
- (c) A combination of the above arrangements.

6.2.2 The scantlings of side stringers supported by web frames, and also of the web frames are to be determined from *Pt 3, Ch 6, 4.5 Primary structure at sides*.

6.2.3 The scantlings of perforated flats are to be determined from *Table 6.6.1 After peak structure*. Stiffeners are to be fitted at every frame.

6.3 Side structure – Longitudinal framing

6.3.1 The spacing and scantlings of side transverses supporting longitudinal framing are to be as required by *Pt 3, Ch 6, 4.5 Primary structure at sides*.

6.3.2 Suitable transverses or deep beams are to be arranged at the top of the tank to provide end rigidity to the side transverses.

Table 6.6.1 After peak structure

Item	Parameter	Requirement
(1) Floors	Thickness	$t = (7,5 + 0,025L_2) \sqrt{\frac{s_2}{800}}$ mm
(2) Perforated flats and wash bulkheads	Thickness see Note	$t = (7,5 + 0,015L) \sqrt{\frac{s_2}{800}}$ mm
	Stiffener modulus	$z = \frac{0,0057 skh_6 t^2}{b} \text{ cm}^3$
Symbols		
= L, s, l_e, k as defined in <i>Pt 3, Ch 6, 1.4 Symbols and definitions 1.4.1</i>		

$b = 1,4$ for rolled or built sections

$= 1,6$ for flat bars

$h_6 =$ vertical distance from middle of effective length of stiffener to top of tank, in metres

$s_2 =$ spacing of stiffeners, in mm, but is to be taken not less than 800 mm

$L_2 = L$ but need not be taken greater than 215 m

Note The thickness for perforated flats and wash bulkheads may be reduced by 1 mm for ships of 40 m and under with no reduction for ships of 90 m and above. Reduction for intermediate lengths to be by linear interpolation.

6.4 Wash bulkheads

6.4.1 A centreline wash bulkhead is to be arranged in the upper part of the after peak space and counter or cruiser stern. Where the overhang is very large, or the breadth of the space at the widest point exceeds 20 m, additional wash bulkheads may be required port and starboard.

6.4.2 Wash bulkheads are to have an area of perforations not less than 5 per cent nor more than 10 per cent of the area of the bulkhead. The plating is to be suitably stiffened in way of openings, and the arrangement of openings is to be such as to maintain adequate shear rigidity.

6.4.3 The scantlings of wash bulkheads are to be determined from *Table 6.6.1 After peak structure*, and stiffeners are to be fitted at every frame and bracketed top and bottom. The plating thickness may be required to be increased locally in way of the upper part of the sternframe or the rudder horn.

6.5 After peak bulkhead

6.5.1 The position and height of the after peak bulkhead are to be in accordance with the requirements of *Pt 3, Ch 3, 4 Bulkhead requirements*.

6.5.2 The scantlings of the after peak bulkhead and of the flat forming the top of the peak space are to be determined from *Pt 4, Ch 1, 9 Bulkheads*, but the plating thickness is to be increased locally in way of the sterntube gland.

■ Section 7 Sternframes and appendages

7.1 General

7.1.1 Sternframes, rudder horns, boss end brackets and shaft brackets may be constructed of cast or forged steel, or may be fabricated from plate.

7.1.2 In castings, sudden changes of section or possible constrictions to the flow of metal during casting are to be avoided. All fillets are to have adequate radii, which should, in general, be not less than 50 to 75 mm, depending on the size of the casting.

7.1.3 Castings and forgings are to comply with the requirements of *Ch 4 Steel Castings* and *Ch 5 Steel Forgings* of the Rules for Materials respectively.

7.1.4 Cast sternframes, rudder horns, shaft brackets and solepieces are to be manufactured from special grade material. Cast bossings can be manufactured from normal grade material, see *Ch 4, 2 Castings for ship and other structural applications* of the Rules for Materials.

7.1.5 Sternframes, rudder horns, shaft brackets, etc. are to be effectively integrated into the ship's structure, and their design is to be such as to facilitate this.

7.2 Sternframes

7.2.1 The scantlings of sternframes are to be determined from *Table 6.7.1 Sternframes*. In the case of very large ships, the scantlings and arrangements may be required to be verified by direct calculations.

Table 6.7.1 Sternframes

Item	Parameter	Requirement		
		Cast steel, see <i>Figure 6.7.1 Propeller posts</i>	Forged steel, see <i>Figure 6.7.1 Propeller posts</i>	Fabricated mild steel, see <i>Figure 6.7.1 Propeller posts</i>
(1) Propeller posts see Notes 1 and 2	l	165 \sqrt{T} mm	-	200 \sqrt{T} mm
	r	20 \sqrt{T} mm	-	18 \sqrt{T} mm
	t_w	8 \sqrt{T} mm (need not exceed 38)	need not exceed 30)	6 \sqrt{T} mm
	t_1	12 \sqrt{T} mm (min. 19)	-	12 \sqrt{T} mm
	t_2	16 \sqrt{T} mm (min.25)	-	-
	w	115 \sqrt{T} mm	40 \sqrt{T} mm	140 \sqrt{T} mm
	A	-	(10+0,5L)T cm ² where L ≤ 60 m 40T cm ² where L > 60 m	-
(2) Propeller boss, see Note 3 and <i>Figure 6.7.2 Propeller boss</i>	t_b	(0,1δ _{TS} + 56) mm, but need not exceed 0,3δ _{TS}		

(3) Rudder posts or axles		Single screw with integral solepiece, see Figure 6.7.6 Solepieces	Single screw with bolted rudder axle, see Figure 6.7.3 Rudder axle	Twin screw, integral with hull, see Figure 6.7.4 Rudder post for twin screw ships
	n	-	6 (see Note 4)	-
	r	-	-	$20 \sqrt{T}$ mm
	r_b	-	δ_A mm	-
	t_F	-	δ_B mm	-
	t_1	-	-	$12 \sqrt{T}$ mm
	t_2	-	-	$15 \sqrt{T}$ mm
	t_3	-	-	$18 \sqrt{T}$ mm
	w	-	-	$120 \sqrt{T}$ mm
	Z_{PB1}, Z_{PB2}	-	$1,2\delta_{PL2}$ mm	-
	Z_T	$0,147 \left(\frac{k_R}{0,248} \right)^3 A_{Rc2} b(V_{0+3})^2 \text{ cm}^3$	-	-
	δ_A	-	$(25T + 76)$ mm but need not exceed $0,9\delta_{PL2}$ mm	-
	δ_b	-	$6,25T + 19$ mm or $0,225\delta_{PL2}$ mm whichever is the greater	-
	$\delta_{PL1}, \delta_{PL2}$ bearing pressure and pintle clearance	-	As for rudder pintles (see Table 13.2.12 Pintle requirements in Chapter 13)	-
(4) Solepieces, see Notes 5, 6 and 7	TZ Z_v A_s		$0,0125M_b K_o$ $0,5Z_T$ $0,02B_1 K_o$	

Symbols

L, T as defined in Pt 3, Ch 6, 1.4 Symbols and definitions 1.4.1

a, b, c = distances, in metres, as shown in Figure 6.7.6 Solepieces

B_1 = see Table 6.7.2 Permissible stresses for sole pieces

c_2 = rudder profile coefficient, as given by Table 13.2.1 Rudder profile coefficient, c_2 in Chapter 13

n = number of bolts in palm coupling

r_b = mean distance of bolt centres from centre of palm, in mm

t_b = finished thickness of boss, in mm

M_B = see Table 6.7.2 Permissible stresses for sole pieces

A = cross-sectional area of forged steel propeller post, in cm^2

A_R = rudder area, in m^2

k_R = rudder coefficient, as given by Table 6.7.4 Rudder coefficient kR

V = maximum service speed, in knots, with the ship in the loaded condition

Z_T = section modulus against transverse bending, in cm^3

Z_V = section modulus against vertical bending, in cm^3

δ_b = diameter of coupling bolts, in mm

δ_{TS} = diameter of tail shaft, in mm

K_O = as defined in Pt 3, Ch 6, 7.3 Rudder horns 7.3.3

A_s = sectional area, in mm^2

Note 1. Where scantlings and proportions of the propeller post differ from those shown in Item (1), the section modulus about the longitudinal axis of the proposed section normal to the post is to be equivalent to that with Rule scantlings. t is to be not less than $8\sqrt{T}$ (minimum of 19 mm for cast steel sternframes) or as required by Pt 3, Ch 6, 3.4 Side shell and sheerstrake 3.4.2, whichever is the greater.

Note 2. On sternframes without solepieces, the modulus of the post below the propeller boss, about the longitudinal axis may be gradually reduced to not less than 85% of that required by Note 1, subject to the same thickness limitations.

Note 3. In fabricated sternframes the connection of the propeller post to the boss is to be by full penetration welds.

Note 4. If more than six bolts are fitted, the arrangements are to provide equivalent strength.

Note 5. In fabricated solepieces, transverse webs are to be fitted spaced not more than 760 mm apart. Where the breadth of the solepiece exceeds 900 mm, a centreline vertical web is also to be fitted.

Note 6. Solepieces supporting fixed or movable nozzles will be specially considered, see Pt 3, Ch 13, 3.2 Nozzle structure.

Note 7. For dredging and reclamation craft classed 'A1 protected waters service', the scantlings of an 'open' type solepiece are to be such that:

(a) $Z_T = 0,625Z_T$

(b) The cross-sectional area is not less than 18 cm^2

(c) The depth is not less than two-thirds of the width at any point.

7.2.2 Fabricated and cast propeller posts and rudder posts of twin screw ships are to be strengthened at intervals by webs. In way of the upper part of the sternframe arch, these webs are to line up with the floors.

7.2.3 Rudder posts and propeller posts are to be connected to floors of increased thickness, see Pt 3, Ch 6, 6.1 Bottom structure.

7.2.4 The sole piece is to be dimensioned such that the stresses do not exceed the permissible stresses given in Table 6.7.2 Permissible stresses for sole pieces.

Table 6.7.2 Permissible stresses for sole pieces

Mode	Permissible stress	
(1) Equivalent stress	115/ K_0 N/mm ²	(11,7/ K_0 kgf/mm ²)
Symbols		
σ_e = equivalent stress $= \sqrt{\sigma_b^2 + 3 \tau_T^2}$ N/mm ²		
σ_b = bending stress $= \frac{M_B}{Z_T}$ N/mm ²		
τ_T = shear stress $= \frac{B_1}{A_s}$ N/mm ²		
K_0 = as defined in Pt 3, Ch 6, 7.3 Rudder horns 7.3.3		
M_B = bending moment, in Nm, at the section considered $= B_1 x$		
B_1 = supporting force, in N, in pintle bearing $= 0,5P_L$		
P_L = rudder force, in N, as calculated in Ch 13,2		
x = distance, in metres, from centre of rudder stock to section under consideration		
Z_T = see Table 6.7.1 Sternframes(4)		
A_s = sectional area, in mm ² , of solepiece		

7.3 Rudder horns

7.3.1 Rudder horns supporting semi-spade type rudders are to be efficiently integrated into the main hull structure, and additional web frames or side transverses may be required in the 'tween deck over.

7.3.2 The shell plating is to be increased in thickness in way of the horn. Where the horn plating is radiused into the shell plating, the radius at the shell connection is to be not less than:

$$r = (150 + 0,8L) \text{ mm}$$

7.3.3 The scantlings of the rudder horn are to be such that the section modulus against transverse bending at any section is not less than:

$$Z_T = 0,015 M_B K_0 \text{ cm}^3$$

where

M_B = bending moment

where

$$= B_{1L} z \text{ Nm}$$

B_{1L} = as calculated in *Table 13.2.12 Pintle requirements*

z = see *Figure 6.7.7 Rudder horn*

$K_o = k_o$ see *Table 13.2.4 Material factor k_o for cast steel*

$K_o = k = 1,0$ for fabricated mild steels

= $k = 0,78$ for high tensile steels with yield stress $\sigma_o = 315 \text{ N/mm}^2$

= $k = 0,72$ for high tensile steels with yield stress $\sigma_o = 355 \text{ N/mm}^2$.

7.3.4 The rudder horn is to be dimensioned such that the stresses do not exceed the permissible stresses given in *Table 6.7.3 Permissible stresses for rudder horns*.

Table 6.7.3 Permissible stresses for rudder horns

Mode	Permissible stress
(1) Shear stress	48/K _o N/mm ² (4,9/K _o kgf/mm ²)
(2) Equivalent stress	120/K _o N/mm ² (12/K _o kgf/mm ²)
Symbols	
<p>σ_e = equivalent stress</p> $= \sqrt{\sigma_b^2 + 3(\tau^2 + \tau_T^2)} \text{ N/mm}^2 (\text{kgf/mm}^2)$ <p>σ_b = bending stress</p> $= \frac{M_B}{Z_T} \text{ N/mm}^2$ <p>τ = shear stress</p> $= \frac{B_{1L}}{A_h} \text{ N/mm}^2$ <p>τ_T = torsional stress</p> $= \frac{10^3 M_T}{2A_T t_h} \text{ N/mm}^2$ <p>A_h = effective shear area, in mm², of rudder horn in y-direction</p> <p>A_T = area in the horizontal section enclosed by the rudder horn, in mm²</p> <p>B_{1L} = as calculated in <i>Table 13.2.12 Pintle requirements</i></p> <p>K_o = as defined in 7.3.3</p> <p>M_B = bending moment at the section considered, in Nm</p> $= B_{1L} z$ <p>M_T = torsional moment at the section considered, in Nm</p> $= B_{1L} e$ <p>t_h = plate thickness of rudder horn, in mm</p> <p>e = see <i>Figure 6.7.7 Rudder horn</i></p> <p>z = see <i>Figure 6.7.7 Rudder horn</i></p> <p>Z_T = see <i>Pt 3, Ch 6, 7.3 Rudder horns 7.3.3</i></p>	

Table 6.7.4 Rudder coefficient k_R

Design criteria		k_R
Ahead condition	Rudder in propeller slipstream	0,248
	Rudder out of propeller slipstream	0,235
Astern condition		0,185
Bow rudder		
Barge – non self– propelled		0,226

Table 6.7.5 Recommended propeller/hull clearances

Number of blades	Hull clearances for single screw, in metres, see Figure 6.7.8 Propeller clearances				Hull clearances for twin screw, in metres, see Figure 6.7.8 Propeller clearances	
	<i>a</i>	<i>b</i>	<i>c</i>	<i>d</i>	<i>e</i>	<i>f</i>
3	1,20Kδ	1,80Kδ	0,12δ	0,03δ	1,20Kδ	1,20Kδ
4	1,00Kδ	1,50Kδ	0,12δ	0,03δ	1,00Kδ	1,20Kδ
5	0,85Kδ	1,275Kδ	0,12δ	0,03δ	0,85Kδ	0,85Kδ
6	0,75Kδ	1,125Kδ	0,12δ	0,03δ	0,75Kδ	0,75Kδ
Minimum value	0,10δ	0,15δ	t_R	—	3 and 4 blades, 0,20δ 5 and 6 blades, 0,16δ	0,15δ

Symbols

L as defined in Pt 3, Ch 6, 1.4 Symbols and definitions 1.4.1

C_b = moulded block coefficient at load draught

$$K = \left(0,1 + \frac{L}{3050} \right) \left(\frac{3,48C_b P}{L^2} + 0,3 \right)$$

$$= \left(K = \left(0,1 + \frac{L}{3050} \right) \left(\frac{2,56C_b P}{L^2} + 0,3 \right) \right)$$

t_R = thickness of rudder, in metres, measured at $0,7R_p$ above the shaft centreline

P = designed power on one shaft, in kW (shp)

R_p = propeller radius, in metres

δ = propeller diameter, in metres

Note The above recommended minimum clearances also apply to semi-spade type rudders.

7.4 Shaft bossing

7.4.1 Where the propeller shafting is enclosed in bossings extending back to the bearings supporting the propellers, the aft end of the bossings and the bearings are to be supported by substantially constructed boss end castings or fabrications. These are to be designed to transmit the loading from the shafting efficiently into the ship's internal structure.

7.4.2 The length of the shaft bracket boss, l_b , is to be sufficient to support the length of the required bearing. In general, l_b is not to be less than $4d_t$, where d_t is the Rule diameter of the screwshaft, in mm, see *Pt 5, Ch 6, 3 Design*. Proposals for a reduction in the required length of the shaft bracket boss will be considered in conjunction with details of the bearing material, allowable bearing operating pressure and installation arrangements. However, in no case is l_b to be less than the greater of:

- (a) $2d_t$; or
- (b) that recommended by the bearing manufacturer; or
- (c) that required to accommodate the aftermost bearing and to allow the proper connection of the shaft bracket .

7.4.3 Where the shaft and the shaft bracket boss are of the same material, the thickness of the shaft bracket boss is not to be less than $d_t/4$. Where the shaft and the shaft bracket boss are of dissimilar materials, the thickness of the boss, t_b , is to be not less than:

$$t_b = 0,75d_t (f_1^{1/3} - 0,667) \text{ mm}$$

Note In no case is t_b to be taken as less than 12 mm

where

d_t = Rule diameter of the screwshaft in way of boss, in the appropriate screwshaft material, in mm, see *Pt 5, Ch 6, 3 Design*:

f_1 = s_S/s_B but not less than 0,825

s_S = ultimate tensile strength of the shaft material, in N/mm^2

s_B = ultimate tensile strength of the boss material, in N/mm^2 .

7.4.4 Cast steel supports are to be suitably radiused where they enter the main hull to line up with the boss plating radius. Where the hull sections are narrow, the two arms are generally to be connected to each other within the ship. The arms are to be strengthened at intervals by webs.

7.4.5 Fabricated supports are to be carefully designed to avoid or reduce the effect of hard spots. Continuity of the arms into the ship is to be maintained, and they are to be attached to substantial floor plates or other structure. The connection of the arms to the bearing boss is to be by full penetration welding.

7.4.6 The scantlings of supports will be specially considered. In the case of certain high powered ships, direct calculations may be required.

7.4.7 The boss plating is generally to be radiused into the shell plating and supported at the aft end by diaphragms at every frame. These diaphragms are to be suitably stiffened and connected to floors or a suitable arrangement of main and deep web frames. At the forward end, the main frames may be shaped to fit the bossing, but deep webs are generally to be fitted not more than four frame spaces apart.

7.4.8 The region where the shafting enters the ship, and the bearing in way, are to be adequately supported by floors or deep webs.

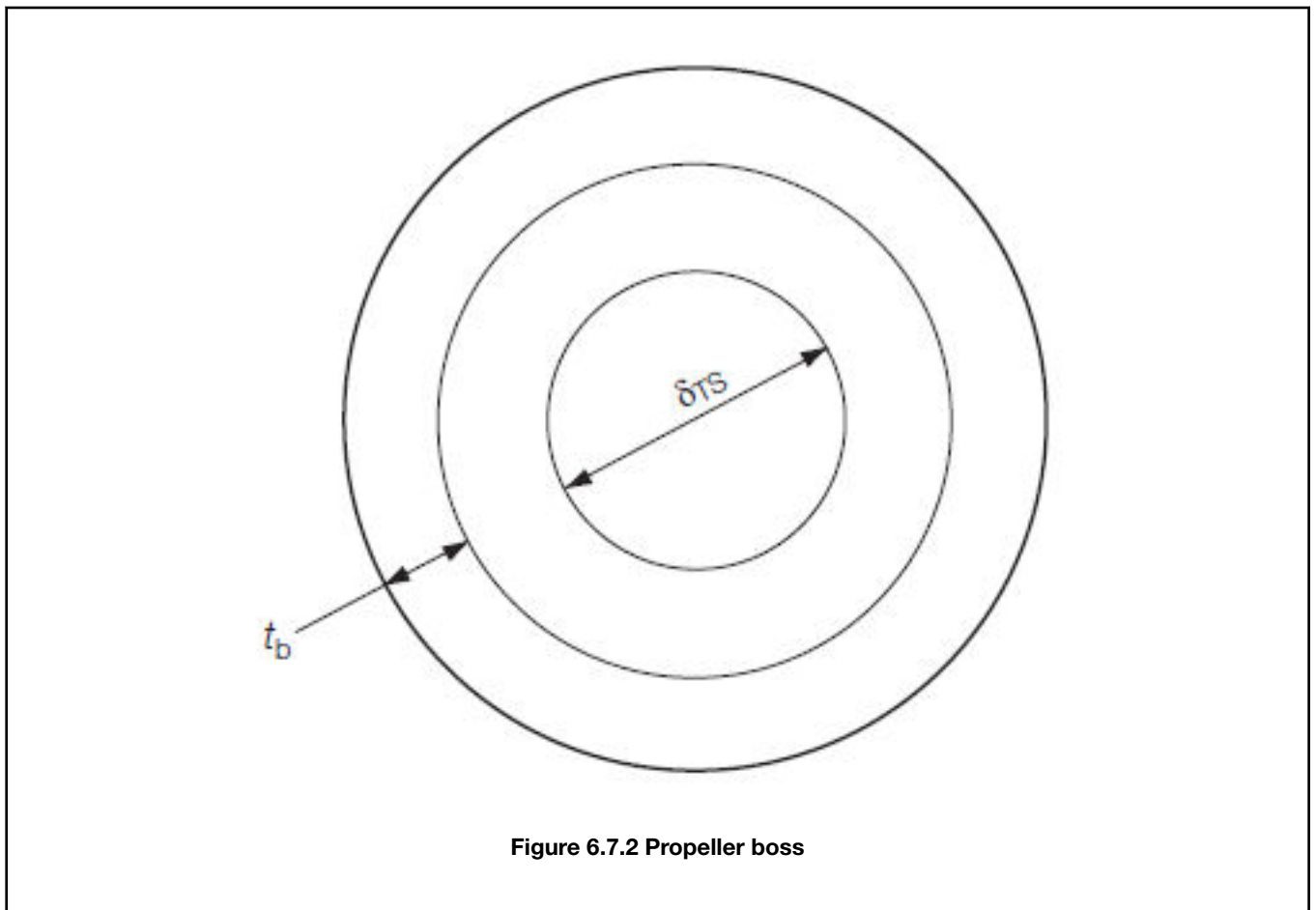
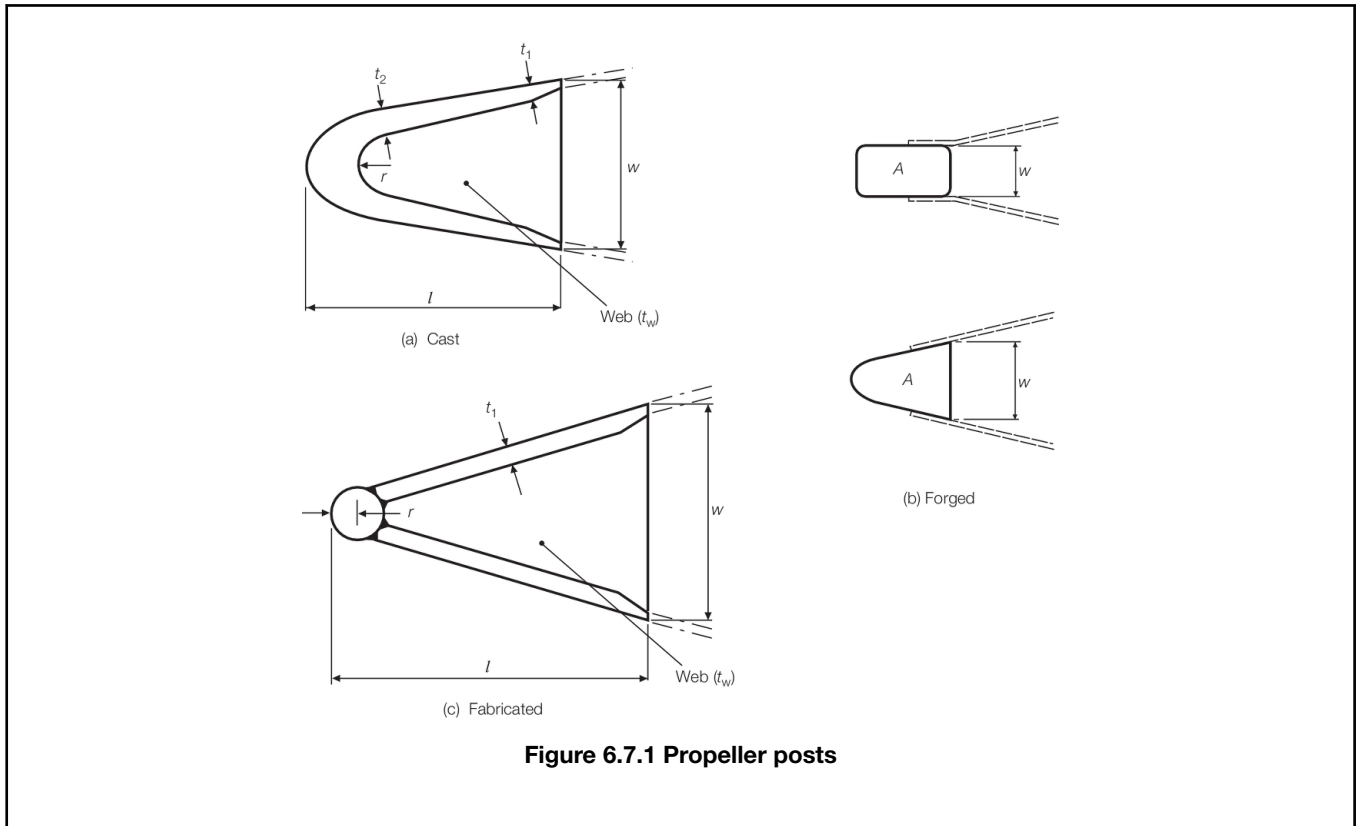

7.5 Shaft brackets

7.5.1 The scantlings of the arms of shaft brackets, generally based on a breadth to thickness ratio of about five, are to be determined in accordance with Pt 3, Ch 6, 7.6 Double arm shaft brackets ('A' – brackets) 7.6.2.

7.5.2 Where the propeller shafting is exposed to the sea for some distance clear of the main hull, it is generally to be supported adjacent to the propeller by independent brackets having two arms. In very small ships, the use of single arm brackets will be specially considered.

7.5.3 Fabricated brackets are to be designed to avoid or reduce the effect of hard spots and ensure a satisfactory connection to the hull structure. The connection of the arms to the bearing boss is to be by full penetration welding.

7.5.4 Where bracket arms are carried through the shell plating, they are to be attached to floors or girders of increased thickness. The shell plating is to be increased in thickness and connected to the arms by full penetration welding.

7.5.5 In the case of certain high powered ships, direct calculations may be required and scantlings of shaft brackets will be specially considered.

7.5.6 The region where the shafting enters the ship, and the bearing in way, is to be adequately supported by floors or deep webs.

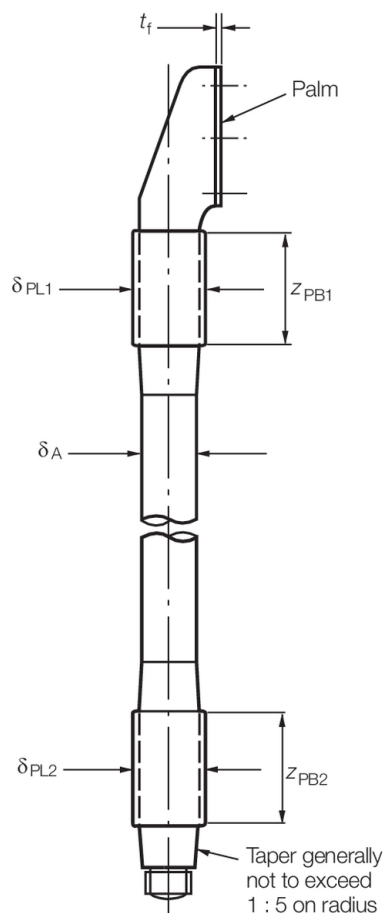

Figure 6.7.3 Rudder axle

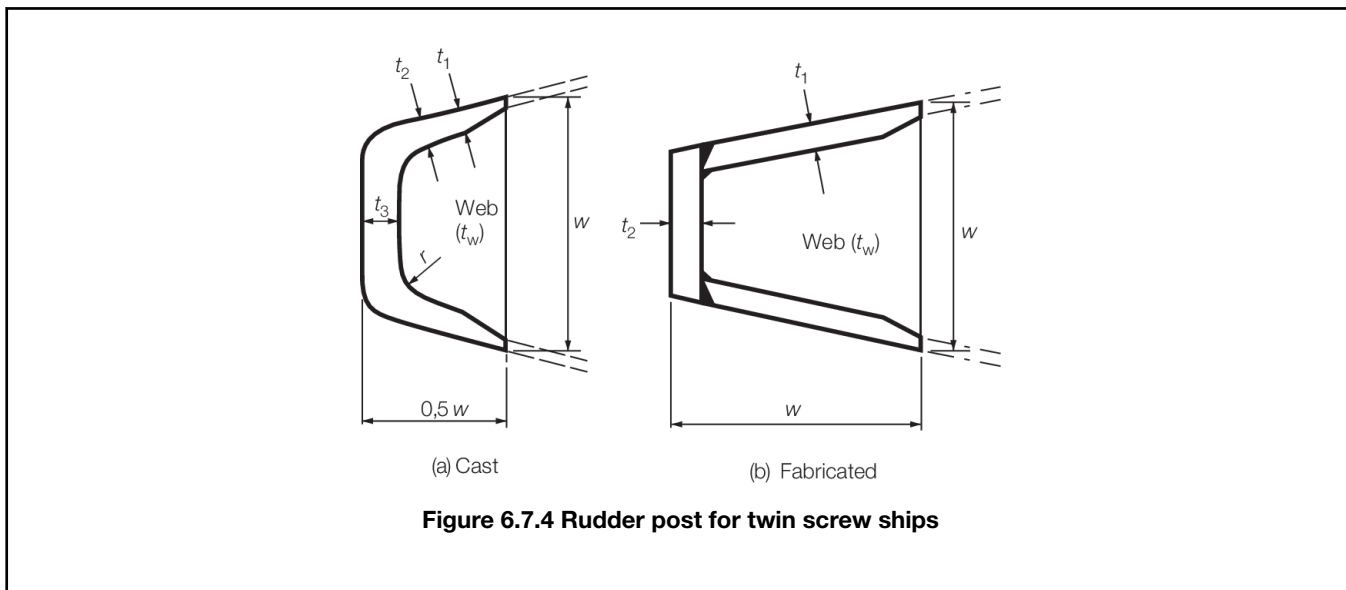

Figure 6.7.4 Rudder post for twin screw ships

7.6 Double arm shaft brackets ('A' – brackets)

7.6.1 The angle between the arms for double arm shaft brackets is generally to be not less than 50°. Proposals for the angle between the arms to be less than 50° will be specially considered with supporting calculations to be submitted by the designers.

7.6.2 The arms of double arm shaft brackets are to have a section modulus, Z_{xx} , of not less than that determined from the formula:

$$Z_{xx} = 0,45n^3 \text{ cm}^3$$

Where

n = the minimum thickness, in cm, of a hydrofoil section obtained from:

$$n = d_{up} \sqrt{\left(\frac{f}{2000}\right) \left(1 + \sqrt{1 + \left(\frac{0,0112}{f}\right) \left(\frac{a_d}{d_{up}}\right)^2}\right)} \text{ cm}$$

a_d = the length of the longer strut, in mm, see Figure 6.7.5 Double arm shaft bracket

d_{up} = the Rule diameter for an unprotected screwshaft, in mm, or by the applicable Ice Class Rules, see Pt 8, Ch 2, 7.8 Screwshafts, obtained from:

$$d_{up} = 128 \sqrt[3]{\frac{P}{R}}$$

P = shaft power, in kW as defined in Pt 5, Ch 1, 3.3 Power ratings

R = revolutions per minute, as defined in Pt 5, Ch 1, 3.3 Power ratings

$$f = 400 / \sigma_u$$

σ_u = ultimate tensile strength of arm material, in N/mm².

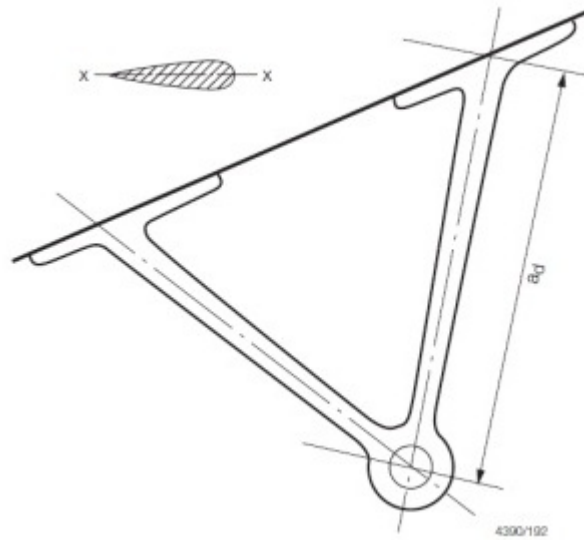

Figure 6.7.5 Double arm shaft bracket

7.7 Propeller hull clearances

7.7.1 Recommended minimum clearances between the propeller and the sternframe, rudder or hull are given in *Table 6.7.5 Recommended propeller/hull clearances*. These are the minimum distances considered desirable in order to expect reasonable levels of propeller excited vibration. Attention is drawn to the importance of the local hull form characteristics, shaft power, water flow characteristics into the propeller disc and cavitation when considering the recommended clearances.

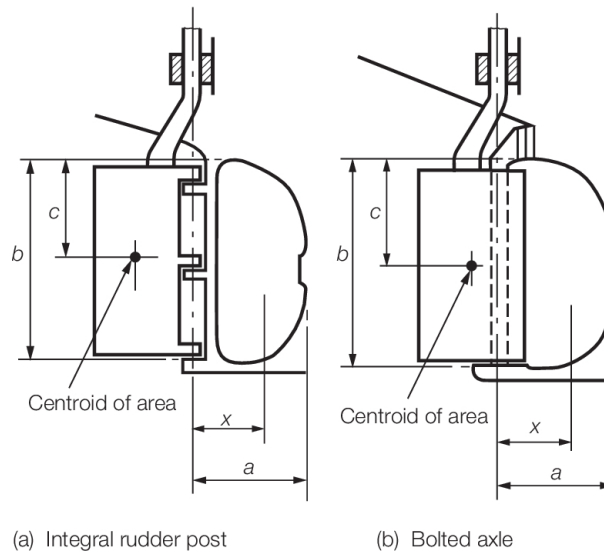
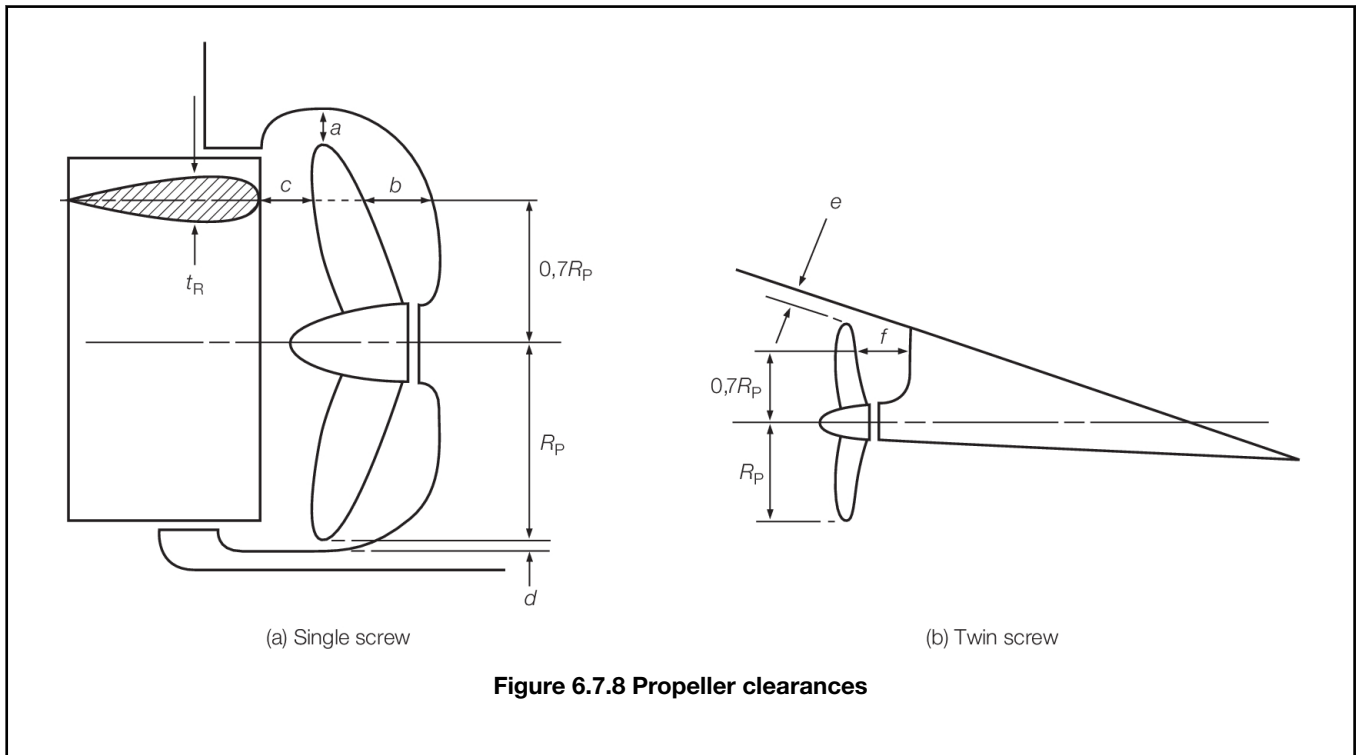
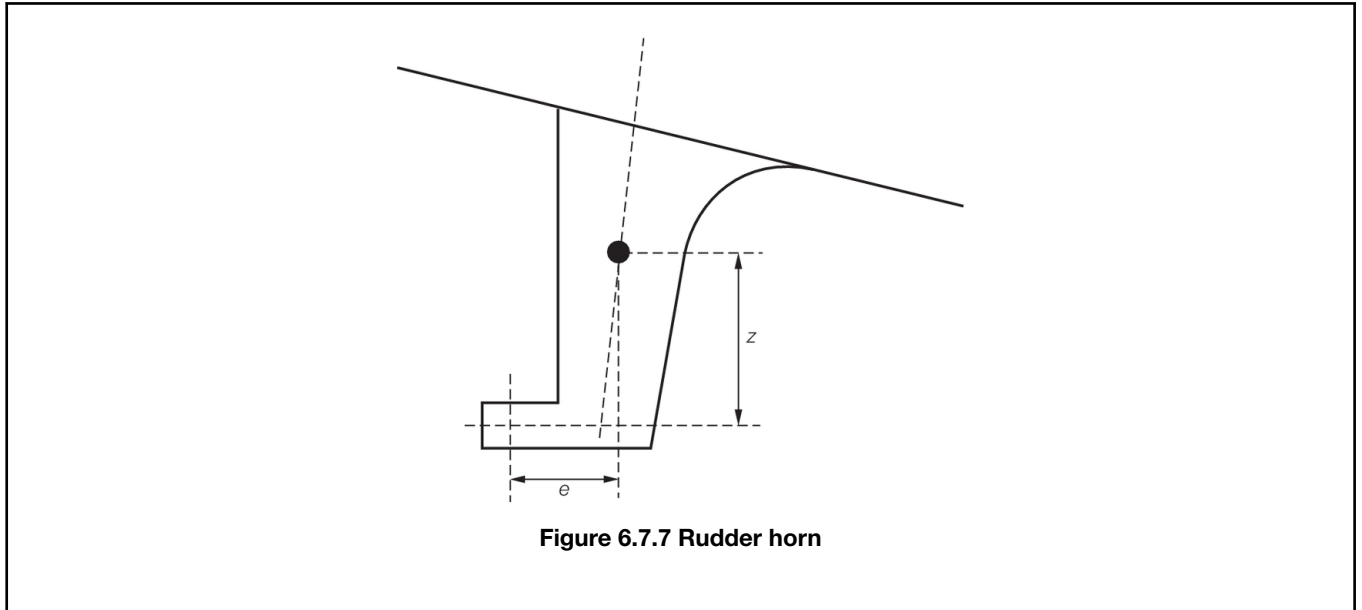

Figure 6.7.6 Solepieces



Section

- 1 **General**
- 2 **Deck structure**
- 3 **Side shell structure**
- 4 **Double and single bottom structure**
- 5 **Machinery casings and fuel oil bunkers**
- 6 **Engine seatings**

■ Section 1 General

1.1 Application

1.1.1 This Chapter applies to all ship types detailed in *Pt 4 Ship Structures (Ship Types)*. Only requirements particular to machinery spaces, including protected machinery casings and engine seatings, are given. For other scantlings and arrangement requirements, see the relevant Chapter in *Pt 4 Ship Structures (Ship Types)* for the particular ship type concerned.

1.1.2 Requirements are given for machinery spaces situated as follows:

- (a) In the midship region.
- (b) In the aft end region but with a cargo compartment between it and the after peak bulkhead.
- (c) In the aft end region where the after peak bulkhead forms the aft end of the machinery space.

1.1.3 The requirements in this Chapter are not applicable to Double Hull Oil Tankers or Bulk Carriers with a **CSR** notation. See *Pt 1, Ch 2, 2.3 Class notations (hull)*.

1.2 Structural configuration

1.2.1 Requirements are given for ships constructed using either a transverse framing system or a longitudinal framing system, or a combination of the two.

1.2.2 For midship machinery spaces, where the shell and decks (outside line of openings) are longitudinally framed in way of adjacent cargo spaces, this system of framing is also to be adopted in the machinery space.

1.2.3 For machinery spaces situated aft, where the longitudinal framing terminates and is replaced by transverse framing, a suitable scarfing arrangement of the longitudinal framing is to be arranged, see also *Pt 3, Ch 6, 1 General*.

1.2.4 The maximum spacing, S_{max} , of transverses in longitudinally framed machinery spaces is not to exceed the following:

- (a) where $L \leq 100$ m, $S_{max} = 3,8$ m
- (b) where $L > 100$ m, $S_{max} = (0,006L + 3,2)$ m

In addition, the spacing in way of a machinery space situated adjacent to the after peak is not to exceed five transverse frame spaces.

1.3 Structural continuity

1.3.1 Suitable scarfing arrangements are to be made to ensure continuity of strength and the avoidance of abrupt discontinuities where structure which contributes to the main longitudinal strength of the ship is omitted in way of a machinery space.

1.3.2 In cargo ships, suitable taper brackets are, in general, to be arranged in way of deck ends.

1.3.3 In oil tankers and bulk carriers with machinery aft (see *Pt 3, Ch 6, 1.1 Application 1.1.3*), continuity of the longitudinal bulkheads and topside tank structure is to be maintained as far as possible into the machinery space with suitable taper brackets at the end.

1.3.4 In container or similar ships having side tanks or double skin construction in way of the cargo spaces, the longitudinal bulkheads are generally to be carried through the machinery space where this is situated amidships or separated from the after peak by a cargo compartment. Where the machinery space is situated adjacent to the after peak, the longitudinal bulkheads are to be continued as far aft as possible and suitably tapered at their ends.

1.4 Symbols and definitions

1.4.1 For symbols not defined in this Chapter, see *Pt 4, Ch 1 General Cargo Ships*. *L*, *B*, *D* and *T* are defined in *Pt 3, Ch 1, 6.1 Principal particulars*. Other symbols are defined in the appropriate Sections.

■ Section 2 Deck structure

2.1 Strength deck – Plating

2.1.1 The corners of machinery space openings are to be of suitable shape and design to minimise stress concentrations.

2.1.2 In the case of oil tankers (see *Pt 3, Ch 6, 1.1 Application 1.1.3*), or other ships having small deck openings amidships and machinery aft, where the width of machinery openings exceeds $\frac{B}{2}$ and the opening extends forward beyond a point $\frac{B}{3}$ aft of the poop front, the thickness of deck plating may be required to be increased locally.

2.2 Strength deck – Primary structure

2.2.1 Where a transverse framing system is adopted, deck beams are to be supported by a suitable arrangement of longitudinal girders in association with pillars or pillar bulkheads. Deep beams are to be arranged in way of the ends of engine casings and also in line with web frames where fitted.

2.2.2 Where a longitudinal framing system is adopted, deck longitudinals are to be supported by transverses in association with pillars or pillar bulkheads. For the maximum spacing of transverses, see *Pt 3, Ch 7, 1.2 Structural configuration 1.2.4*. Deck transverses are to be in line with side transverses or web frames.

2.2.3 Machinery casings are to be supported by a suitable arrangement of deep beams or transverses and longitudinal girders in association with pillars or pillar bulkheads. In way of particularly large machinery casing openings, cross ties may be required, and these are to be arranged in line with deep beams or transverses.

2.3 Lower decks

2.3.1 The scantlings of lower decks or flats are generally to be as detailed in *Pt 3, Ch 5, 2 Deck structure*, *Pt 3, Ch 6, 2 Deck structure* or *Pt 4, Ch 1, 4 Deck structure*, as appropriate. However, in way of concentrated loads such as those from boiler bearers or heavy auxiliary machinery, etc. the scantlings of deck structure will be specially considered, taking account of the actual loading.

2.3.2 In way of machinery openings, etc. particularly towards the aft end, decks or flats are to have sufficient strength where they are intended as effective supports for side framing, webs or transverses. Web frames and side transverses are to be supported by deep beams or deck transverses.

■ Section 3 Side shell structure

3.1 Secondary stiffening

3.1.1 Transverse frames are generally to have scantlings determined as required by *Pt 4, Ch 1, 6 Shell envelope framing* for cargo spaces, except that where, in a machinery space situated in the midship region, it is desired to omit web frames as permitted by *Pt 3, Ch 7, 3.2 Primary structure – Transverse framing 3.2.3*, the section modulus of the ordinary main or 'tween deck frames is to be increased by 50 per cent, up to the level of the lowest deck above the load waterline. Where fully effective

stringers supported by web frames are fitted, the stringers may be considered as decks for the purpose of calculating the modulus of the frames.

3.1.2 Longitudinal framing is generally to have scantlings determined as required by *Pt 4, Ch 1, 6 Shell envelope framing* for machinery spaces in the midship region, and by *Table 6.4.1 Shell framing (longitudinal) aft* Location 2(b) in Chapter 6 for machinery spaces clear of and aft of the midship region.

3.2 Primary structure – Transverse framing

3.2.1 Where the space is situated in the aft end region, web frames are to be fitted, spaced in general not more than five frame spaces apart, extending from the tank top to the upper deck and having scantlings as required by *Table 7.3.1 Primary structure in machinery spaces*. However, consideration will be given to a spacing of web frames at not more than seven transverse frame spaces apart, in association with substantially increased ordinary frames to satisfy the overall modulus and inertia requirements. The web frames are to be connected at top and bottom to members of adequate stiffness and supported at lower decks by deep beams. If the span of ordinary frames below the lowest deck or flat exceeds 6,5 m, one or more fully effective side stringers are to be fitted to support the frames. These are to have scantlings as required by *Table 7.3.1 Primary structure in machinery spaces*. Stringers are to be efficiently bracketed to bulkheads, and their connection to the web frames is to be such as to provide adequate continuity of face material.

3.2.2 As an alternative to the fully effective stringers required by *Pt 3, Ch 7, 3.2 Primary structure – Transverse framing 3.2.1*, an arrangement of light stringers spaced about 2,5 m apart may be accepted. These stringers are to have scantlings not less than those required in the panting region forward, see *Pt 3, Ch 5, 4.4 Panting stringers in way of transverse framing*.

3.2.3 Where the machinery space is situated in the midship region, it is recommended that web frames be fitted in the engine-room, spaced not more than five frame spaces apart and extending from the tank top to the level of the lowest deck above the load waterline. The scantlings of these webs are to be such that the combined section modulus of the web frame and the main or 'tween deck frames is 50 per cent greater than that required for normal transverse framing. These webs may be omitted if the section modulus of the transverse frames is increased as required by *Pt 3, Ch 7, 3.1 Secondary stiffening 3.1.1*.

3.2.4 If an effective side stringer supporting the side frames is fitted, then its scantlings and those of the supporting web frames are to be determined from *Table 7.3.1 Primary structure in machinery spaces*.

3.3 Primary structure – Longitudinal framing

3.3.1 Where the machinery space is longitudinally framed, side transverses are to be fitted having scantlings as required by *Table 7.3.1 Primary structure in machinery spaces*. For the maximum spacing of transverses, see *Pt 3, Ch 7, 1.2 Structural configuration 1.2.4*. Transverses are to be connected at top and bottom to members of adequate stiffness and supported at lower decks by transverses or deep beams.

Table 7.3.1 Primary structure in machinery spaces

Symbols	Item and position	Scantlings	
		Section modulus, in cm ³	Min. web depth d_w , in mm
<p>L, D and T are as defined in Pt 3, Ch 1, 6.1 Principal particulars</p> <p>h = load head, in metres, measured from mid-point of span to upper deck at side amidships</p> <p>k = higher tensile and steel factor, see Pt 3, Ch 2, 1.2 Steel</p> <p>l_e = effective length of stiffening member, in metres, see Pt 3, Ch 3, 3.3 Determination of span point</p> <p>s = spacing of floors and longitudinals, in mm</p> <p>C = 2,2 for a lower 'tween deck or 2,0 for an upper 'tween deck</p> <p>S = spacing or mean spacing of primary supporting members, in metres</p>	<p>TRANSVERSE FRAMING SYSTEM</p> <p>Aft end region: Web frames below lowest deck and not supporting effective stringers</p>	$Z = 5kShl_e^2$	2,5 × depth of adjacent main frames
	<p>Web frames above lowest deck</p>	$Z = 1,68CkTSl_e\sqrt{D}$	2,5 × depth of adjacent main frames
	<p>Any region: Fully effective stringers</p>	$Z = 7,75kShl_e^2$	
	<p>Web frames below lowest deck supporting effective stringers</p>	<p>Determined from calculation based on following assumptions:</p> <p>(a) Fixed ends</p> <p>(b) Point loadings</p> <p>(c) Head to upper deck at side</p> <p>(d) Bending stress 93,2 N/mm² (9,5 kgf/mm²)</p> <p>(e) Shear stress 83,4 N/mm² (8,5 kgf/mm²)</p>	
	<p>LONGITUDINAL FRAMING SYSTEM</p> <p>Side transverses below lowest deck</p> <p>Side transverses above lowest deck</p>	$Z = 10kShl_e^2$ $Z = 2,1CkTSl_e\sqrt{D}$	2,5 × depth of longitudinals

■ Section 4

Double and single bottom structure

4.1 Double bottom structure

4.1.1 The minimum depth of the centre girder and its thickness are to be at least the same as required in way of cargo space amidships, see *Pt 4, Ch 1, 8 Double bottom structure*. A greater depth is recommended in way of large engine-rooms when the variation in draught between light and load conditions is considerable. For passenger ships, see *Pt 4, Ch 2, 6 Double bottom*.

4.1.2 In machinery spaces situated adjacent to the after peak, the double bottom is to be transversely framed. Elsewhere transverse or longitudinal framing may be adopted, but see also *Pt 4, Ch 1, 8 Double bottom structure*.

4.1.3 Where the double bottom is transversely framed, plate floors are to be fitted at every frame in the engine-room. In way of boilers, plate floors are to be fitted under the boiler bearers, and elsewhere as required by *Pt 4, Ch 1, 8 Double bottom structure*.

4.1.4 Where the double bottom is longitudinally framed, plate floors are to be fitted at every frame under the main engines and thrust bearing. Outboard of the engine seating, floors may be fitted at alternate frames, see *Figure 7.4.1 Engine-room with longitudinal framing*.

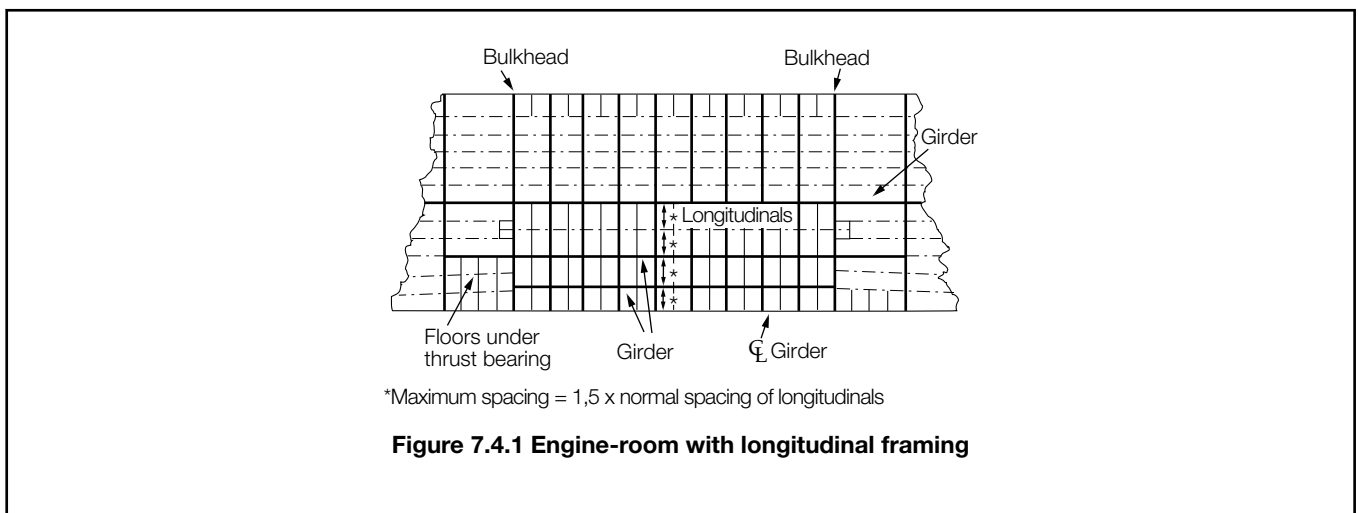

4.1.5 The scantlings of floors clear of the main engine seatings, are generally to be as required in way of cargo spaces, see *Pt 4, Ch 1, 8 Double bottom structure*. In way of engine seatings, the floors are to be increased in thickness, see *Pt 3, Ch 7, 6.2 Seats for oil engines 6.2.1*.

4.1.6 Sufficient fore and aft girders are to be arranged in way of the main machinery to effectively distribute its weight and to ensure adequate rigidity of the structure. In midship machinery spaces these girders are to extend for the full length of the space and are to be carried aft to support the foremost shaft tunnel bearing. This extension beyond the after bulkhead of the engine-room is to be for at least three transverse frame spaces, aft of which the girders are to scarf into the structure. Forward of the engine-room bulkhead, the girders are to be tapered off over three frame spaces and effectively scarfed into the structure. In machinery spaces situated at the aft end the girders are to be carried as far aft as practicable and the ends effectively supported by web frames or transverses. For recommended scantlings of engine girders, see *Pt 3, Ch 7, 6.2 Seats for oil engines 6.2.1*.

4.1.7 Outboard of the engines, side girders are to be arranged, where practicable, to line up with the side girders in adjacent cargo spaces. These are to have scantlings as required by *Pt 4, Ch 1, 8 Double bottom structure*.

4.1.8 Where the double bottom is longitudinally framed and transverse floors are fitted in way of the engine seatings as required by *Pt 3, Ch 7, 4.1 Double bottom structure 4.1.4*, no additional longitudinal stiffening is required in way of the engines other than the main engine girders, provided that the spacing of girders does not exceed 1,5 times the normal spacing of longitudinals. Where this spacing of girders is exceeded, shell longitudinals are to be fitted. These are to scarf into the longitudinal framing clear of the machinery spaces. The scantlings of the longitudinals are to be determined as required by *Pt 4, Ch 1, 6 Shell envelope framing* using a minimum span of 1,3 m, see *Figure 7.4.1 Engine-room with longitudinal framing*.

4.1.9 The thickness, t , of inner bottom plating in engine-rooms, clear of the engine seatings, is to be not less than:

$$t = 0,0015 \sqrt[4]{L T k^2 (s + 660)} \text{ mm}$$

and not less than 7,0 mm (symbols as defined in *Table 7.3.1 Primary structure in machinery spaces*). This thickness will be required to be increased in way of engine seatings integral with the tank top, see *Pt 3, Ch 7, 6.2 Seats for oil engines 6.2.1*.

4.1.10 Where the height of inner bottom in the machinery spaces differs from that in adjacent spaces, continuity of longitudinal material is to be maintained by sloping the inner bottom over an adequate longitudinal extent. The knuckles in the plating are to be arranged close to plate floors.

4.2 Single bottom structure

4.2.1 In way of machinery spaces situated amidships the minimum depth of floors is to be at least 10 per cent greater than that required elsewhere in general cargo ships, see *Pt 4, Ch 1, 7 Single bottom structure*. If the top of the floors is recessed in way of the engines, the depth of the floors in way of the recess should generally be not less than that required by *Pt 4, Ch 1, 7 Single bottom structure*, but this will be specially considered in each case in relation to the arrangements proposed.

4.2.2 In way of machinery spaces situated aft, or where there is considerable rise of floor, the depth of the floors will be specially considered.

4.2.3 Clear of the engine seatings the thickness and face plate area of the floor webs are to be 1,0 mm and 10 per cent greater, respectively, than the requirements for general cargo ships as given in *Pt 4, Ch 1, 7 Single bottom structure*. The floors are not to be flanged.

4.2.4 Sufficient fore and aft girders are to be arranged in way of machinery to effectively distribute its weight and ensure adequate rigidity of the structure. In midship machinery spaces these girders are to extend for the full length of the space and are to be carried aft to support the foremost shaft tunnel bearing and forward to scarf into the structure. In machinery spaces situated at the aft end, the girders are to be carried as far aft as practicable and the ends effectively supported by web frames or transverses. For scantlings of engine girders, see *Pt 3, Ch 7, 6.2 Seats for oil engines 6.2.1*.

4.2.5 Outboard of the engines, side girders are to be arranged having scantlings as required by *Pt 4, Ch 1, 7 Single bottom structure* and these are to be scarfed into the side girders in adjacent spaces.

■ Section 5 Machinery casings and fuel oil bunkers

5.1 Machinery casings

5.1.1 The scantlings and arrangements of exposed casings protecting machinery openings are to be in accordance with *Pt 3, Ch 8, 2 Scantlings of erections other than forecastles*.

5.1.2 The minimum scantlings of protected casings are to be in accordance with *Table 7.5.1 Protected machinery casings*.

Table 7.5.1 Protected machinery casings

Item	Minimum scantlings
Plating:	
In way of cargo hold spaces	$t = 6,5\sqrt{k}$ mm
In way of accommodation spaces	$t = 5,0\sqrt{k}$ mm
Stiffeners	$Z = 0,008l_e s k$ cm ³
Symbols	
k = higher tensile steel factor, see <i>Pt 3, Ch 2, 1.2 Steel</i>	

l_e = effective length of stiffening member, in metres, see Pt 3, Ch 3, 3.3 Determination of span point

s = spacing of stiffeners, in mm

t = thickness, in mm

Z = section modulus of stiffening member, in cm^3 , see Pt 3, Ch 3, 3.2 Geometric properties of section

Note In no case is the depth of the stiffener to be less than 60 mm.

5.1.3 Where casing stiffeners carry loads from deck transverses, girders, etc. or where they are in line with pillars below, they are to be suitably increased, see also Pt 4, Ch 1, 4 Deck structure.

5.1.4 Where casing sides act as girders supporting decks over, care is to be taken that access openings do not seriously weaken the structure. Openings are to be effectively framed and reinforced if found necessary. Particular attention is to be paid to stiffening where the casing supports the funnel or exhaust uptakes.

5.2 Fuel oil bunkers

5.2.1 Fuel oil bunkers situated within the machinery space are generally to comply with the requirements given in Pt 4, Ch 1 General Cargo Ships or Pt 3, Ch 9 Special Features, as appropriate.

■ Section 6 Engine seatings

6.1 General

6.1.1 Main engines and thrust bearings are to be effectively secured to the hull structure by seatings of adequate scantlings to resist the various gravitational, thrust, torque, dynamic and vibratory forces which may be imposed on them.

6.1.2 For initial guidance, recommended scantlings for oil engine seatings are given in Pt 3, Ch 7, 6.2 Seats for oil engines 6.2.1.

6.1.3 In the case of higher power oil engines or turbine installations the seatings should generally be integral with the double bottom structure. The tank top plating in way of the engine foundation plate or the turbine gear case and the thrust bearing should be substantially increased in thickness, see Figure 7.6.1 Engine seatings, Type 1.

6.1.4 If the main machinery is supported on seatings of Type 2 as shown in Figure 7.6.1 Engine seatings, these are to be so designed that they distribute the forces from the engine as uniformly as possible into the supporting structure. Longitudinal members supporting the seating are to be arranged in line with girders in the double bottom, and adequate transverse stiffening is to be arranged in line with floors, see Figure 7.6.1 Engine seatings, Type 2.

6.1.5 In ships having open floors in the machinery space the seatings are generally to be arranged above the level of the top of floors and securely bracketed to them, see Figure 7.6.1 Engine seatings, Type 3.

6.2 Seats for oil engines

6.2.1 In determining the scantlings of seats for oil engines, consideration is to be given to the general rigidity of the engine itself and to its design characteristics in regard to out of balance forces. As a general guide to designers, recommended scantlings are given in Table 7.6.1 Seats for oil engines - Recommended scantlings.

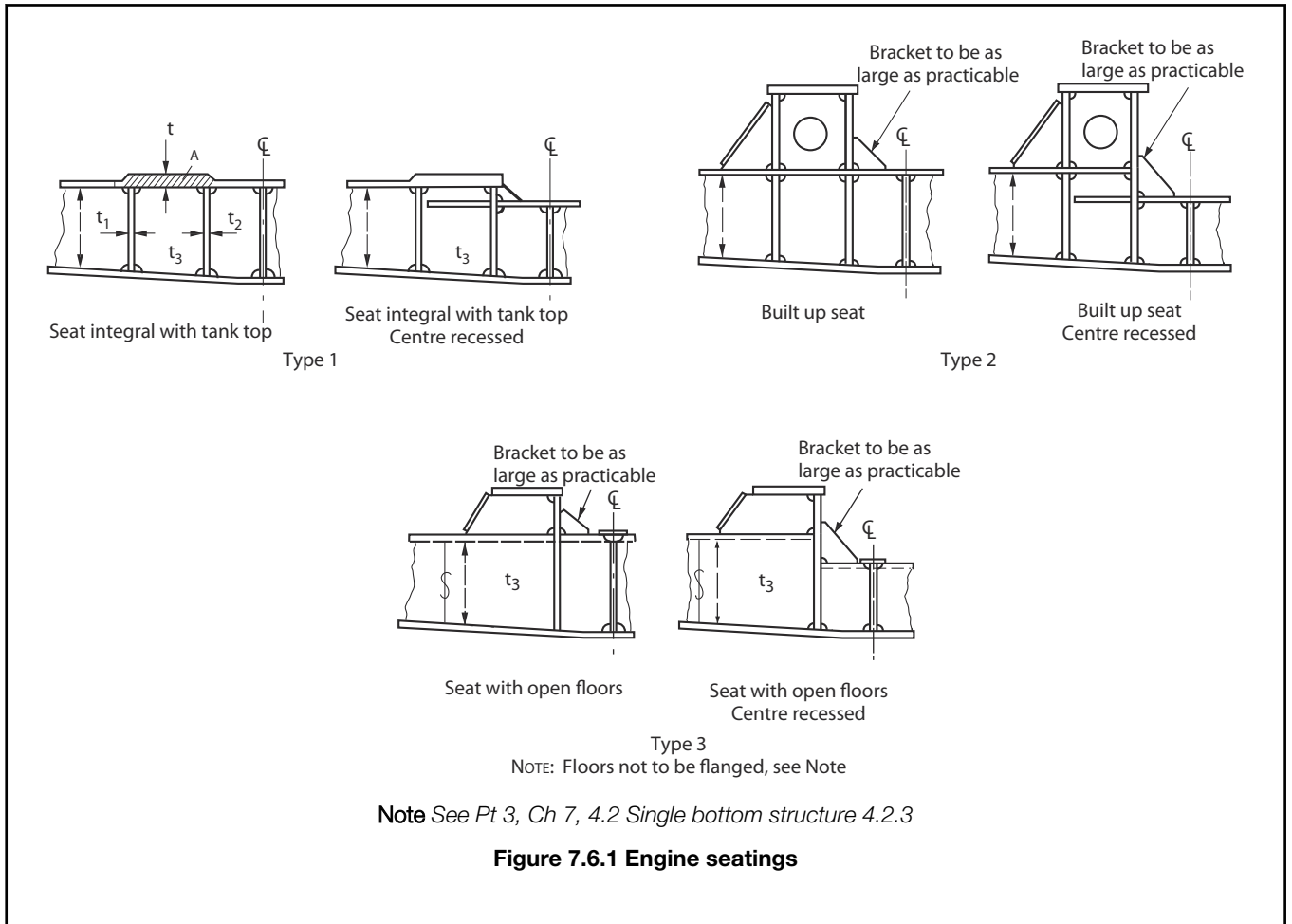

Table 7.6.1 Seats for oil engines - Recommended scantlings

Symbols	Item	Scantlings of one seat
<p>L as defined in Pt 3, Ch 1, 6.1 Principal particulars</p> <p>f = engine factor = $\frac{P}{Rl}$</p> <p>t = minimum thickness of top plate, in mm</p>	<p>Top plate</p>	<p>$A = (120 + 44,2f + 4,07f^2) \text{ cm}^2$ $(A = (120 + 32,5f + 2,2f^2) \text{ cm}^2)$</p>
<p>t_1, t_2 = main engine girder thicknesses, in mm</p> <p>t_3 = floor plate thickness under seating, in mm, see also Figure 7.6.1 Engine seatings</p> <p>A = area of top plate for one side of seat, in cm^2</p>		<p>Minimum thickness:</p> <p>(a) Where two girders fitted</p> <p>$t = (19 + 3,4f)$ mm $(t = (19 + 2,5f)$ mm)</p> <p>(b) Where one girder fitted</p> <p>$t = (25 + 3,4f)$ mm $(t = (25 + 2,5f)$ mm)</p>
	<p>Girders (both inside and above double bottom where fitted)</p>	<p>Number:</p>
<p>where</p> <p>l = effective length of engine foundation plate, in metres, required for bolting the engine to the seating.</p> <p>= The thrust and gearcase seating is to be considered as a separate item</p> <p>P = power of one engine at maximum service speed, in kW (bhp)</p>		<p>Generally two but a single girder can be accepted where all the following apply:</p> <p>(a) $f < 1,84$ (2,5)</p> <p>(b) $P < 5900$ kW (8000 bhp)</p> <p>(c) $L < 100$ m</p>

<p>R = rev/min of engine at maximum service speed</p>		<p>Total thickness:</p> <p>(a) Where two girders are fitted</p> $t_1 + t_2 = (28 + 4,08f) \text{ mm}$ $(t_1 + t_2 = (28 + 3,0f) \text{ mm})$ <p>(b) Where one girder is fitted</p> $t_1 = (15 + 4,08f) \text{ mm}$ $(t_1 = (15 + 3,0f) \text{ mm})$
	<p>Floors (between girders or under seat where a single girder is fitted)</p>	<p>Thickness:</p> $t_3 = (10 + 1,5f) \text{ mm}$ $(t_3 = (10 + 1,1f) \text{ mm})$

6.3 Seats for turbines

6.3.1 Seats are to be so designed as to provide effective support for the turbines and ensure their proper alignment with the gearing, and (where applicable) allow for thermal expansion of the casings. In general, the seats are not to be arranged in way of breaks or recesses in the double bottom.

6.4 Seats for boilers

6.4.1 Boiler bearers are to be of substantial construction and efficiently supported by transverse and horizontal brackets. These should generally be arranged in line with plate floors and girders in a double bottom or with suitable deep beams or transverses and girders at boiler flats. Suitable allowance is to be made in the design of the supporting structure for the variation in loading due to thermal expansion effects, *see also Pt 5, Ch 14, 2 Fuel oil - General requirements.*

6.5 Seats for auxiliary machinery

6.5.1 Auxiliary machinery is to be secured on seatings, of adequate scantlings, so arranged as to distribute the loadings evenly into the supporting structure.

Section

- 1 **General**
- 2 **Scantlings of erections other than forecastles**
- 3 **Aluminium erections**
- 4 **Forecastles**
- 5 **Bulwarks, guard rails and other means for the protection of crew**

■ **Section 1**
General

1.1 Application

1.1.1 This Chapter applies to all types of ships detailed in *Pt 4 Ship Structures (Ship Types)*, except for deckhouses situated on forecastles of offshore supply ships, which are dealt with separately in *Pt 4, Ch 4 Offshore Support Vessels*.

1.1.2 The scantlings of exposed bulkheads and decks of superstructures and deckhouses are generally to comply with the following requirements, but increased scantlings may be required where the structure is subjected to loading additional to Rule. Where there is no access from inside the house to below the freeboard deck, or where a bulkhead is in a particularly sheltered location, the scantlings may be specially considered.

1.1.3 The term 'erection' is used in this Section to include both superstructures and deckhouses.

1.1.4 For requirements relating to companionways, doors, accesses and skylights, see *Pt 3, Ch 11 Closing Arrangements for Shell, Deck and Bulkheads*.

1.1.5 The requirements in this Chapter are not applicable to Double Hull Oil Tankers or Bulk Carriers with a **CSR** notation. See *Pt 1, Ch 2, 2.3 Class notations (hull)*.

1.2 Symbols

1.2.1 The following symbols and definitions are applicable to this Chapter, unless otherwise stated:

L, B, T and C = as defined in *Pt 3, Ch 1, 6.1 Principal particulars*

b

b = breadth of deckhouse, at the positions under consideration, in metres

k = higher tensile steel factor, see *Pt 3, Ch 2, 1.2 Steel*

l_e = effective length, in metres, of the stiffening member, deck beam or longitudinal measured between span points, see *Pt 3, Ch 3, 3.3 Determination of span point*

l_s = span, in metres, of stiffeners, and is to be taken as the 'tween deck or house height but in no case as less than 2,0 m

s = spacing of stiffeners, beams or longitudinals, in mm

s_b = standard spacing, in mm, of stiffeners, beams or longitudinals, and is to be taken as:

= (a) for 0,05L from the ends:

= $s_b = 610$ mm or that required by (b), whichever is the lesser

= (b) elsewhere:

= $s_b = 470 + 1,67L_2$ mm

= but forward of $0,2L$ from the forward perpendicular s_b is not to exceed 700 mm

B_1 = actual breadth of ship, at the section under consideration, measured at the weather deck, in metres

D = moulded depth of ship, in metres, to the uppermost continuous deck or the deck next above a height of $1,6T$ from the base line amidships, whichever is the lesser

L_2 = length of ship, in metres, but is not to be taken greater than 250 m or less than 50 m

L_3 = length of ship, in metres, but is not to be taken greater than 300 m

X = distance, in metres, between the after perpendicular and the bulkhead under consideration. When determining the scantlings of deckhouse sides, the deckhouse is to be subdivided into parts of approximately equal length not exceeding $0,15L$ each, and X is to be measured to the mid-length of each part

α = a coefficient given in *Table 8.1.1 Values of α*

$$\beta = 1,0 + \left(\frac{\left(\frac{X}{L} - 0,45 \right)}{\left(C_b + 0,2 \right)} \right)^2 \text{ for } \frac{X}{L} \leq 0,45$$

$$= 1,0 + 1,5 \left(\frac{\left(\frac{X}{L} - 0,45 \right)}{\left(C_b + 0,2 \right)} \right)^2 \text{ for } \frac{X}{L} > 0,45$$

= C_b is to be taken as not less than 0,6 nor greater than 0,8. Where the aft end of an erection is forward of amidships, the value of C_b used in determining β for the aft end bulkhead need be taken as not less than 0,8

γ = vertical distance, in metres, from the summer load waterline to the mid-point of span of the bulkhead stiffener, or the mid-point of the plate panel, as appropriate

δ = 1,0 for exposed machinery casings and houses protecting openings to pump-rooms

$$= \left(0,3 + 0,7 \frac{b}{B_1} \right) \text{ elsewhere, but in no case to be taken less than } 0,475$$

λ = a coefficient given in *Table 8.1.2 Values of λ* .

1.3 Definition of tiers

1.3.1 The lowest, or first tier, is normally that which is directly situated on the deck to which D is measured. The second tier is the next tier above the lowest tier and so on.

Table 8.1.1 Values of α

Position			α
Lowest tier	-	unprotected front	$2,0 + 0,0083L_3$
Second tier	-	unprotected front	$1,0 + 0,0083L_3$
Third tier and above	-	unprotected front	$0,5 + 0,0067L_3$
All tiers	-	protected fronts	
All tiers	-	sides	

All tiers	-	aft end where aft of amidships	$0,7 + 0,001L_3 - 0,8 \frac{X}{L}$
All tiers	-	aft end where forward of amidships	$0,5 + 0,001L_3 - 0,4 \frac{X}{L}$

Table 8.1.2 Values of λ

Length L	λ	Expression for λ
metres		
20	0,89	
30	1,76	
40	2,57	
50	3,34	
60	4,07	$L \leq 150 \text{ m}$
70	4,76	$\lambda = \left(\frac{L}{10} e^{-\frac{L}{300}} \right) - \left(1 - \left(\frac{L}{150} \right)^2 \right)$
80	5,41	
90	6,03	
110	7,16	
130	8,18	
150	9,10	
150	9,10	
170	9,65	
190	10,08	
210	10,43	
230	10,69	$150 \text{ m} \leq L \leq 300 \text{ m} \lambda = \frac{L}{10} e^{-\frac{L}{300}}$
250	10,86	
270	10,98	
290	11,03	
300	11,03	
300 and above	11,03	$L \geq 300 \text{ m}$ $\lambda = 11,03$

1.3.2 Where the freeboard corresponding to the required summer moulded draught for the ship can be obtained by considering the ship to have a virtual moulded depth at least one standard superstructure height less than the Rule depth, D , measured to the uppermost continuous deck, proposals to treat the first tier erection as a second tier, and so on, will be specially considered. The standard height of superstructure is the height defined in the *International Convention on Load Lines, 1966*.

1.4 Design pressure head

1.4.1 The design pressure head, h , to be used in the determination of erection scantlings is to be taken as:

$$h = \alpha \delta (\beta \lambda - \gamma) \text{ m}$$

1.4.2 In no case is the design pressure head to be taken as less than the following:

- (a) Lowest tier of unprotected fronts:

minimum $h = 2,5 + 0,01L_2$ m

(b) All other locations:

minimum $h = 1,25 + 0,005L_2$ m.

■ **Section 2**
Scantlings of erections other than forecastles

2.1 Thickness of bulkhead and side plating

2.1.1 The thickness, t , of plating of the fronts, sides and aft ends of all erections, other than the sides of superstructures where these are an extension of the side shell, is to be not less than:

$$t = 0,003s\sqrt{kh} \text{ mm}$$

but in no case is the thickness to be less than:

(a) for the lowest tier:

$$t = (5,0 + 0,01L_3)\sqrt{k} \text{ mm}$$

(b) for the upper tiers:

$$t = (4,0 + 0,01L_3)\sqrt{k} \text{ mm but not less than } 5,0 \text{ mm}$$

2.1.2 The thickness of sides of poops and bridges is to be as required by *Pt 3, Ch 6, 3 Shell envelope plating* or *Pt 4, Ch 1, 5 Shell envelope plating*, as appropriate.

2.2 Stiffeners and their connections

2.2.1 The modulus of stiffeners, Z , on front, side and end bulkheads of all erections, other than sides of superstructures, is to be not less than:

$$Z = 0,0035hs l_s^2 k \text{ cm}^3$$

2.2.2 The section modulus of side frames of poops and bridges is to comply with the requirements of *Pt 3, Ch 6, 4 Shell envelope framing* or *Pt 4, Ch 1, 6 Shell envelope framing*, as appropriate.

2.2.3 The end connections of stiffeners are to be as given in *Table 8.2.1 Stiffener end connections*.

2.3 Deck plating

2.3.1 The thickness of erection deck plating is to be not less than that required by *Table 8.2.2 Thickness of deck plating*.

2.3.2 When decks are fitted with approved sheathing, the thicknesses derived from *Table 8.2.2 Thickness of deck plating* may be reduced by 10 per cent for a 50 mm sheathing thickness, or 5 per cent for 25,5 mm, with intermediate values in proportion. The steel deck is to be coated with a suitable material in order to prevent corrosive action, and the sheathing or composition is to be effectively secured to the deck, see also *Pt 6, Ch 4 Fire Protection, Detection and Extinction Requirements*. Inside deckhouses the thickness may be reduced by a further 10 per cent.

Table 8.2.1 Stiffener end connections

Position		Attachment at top and bottom
1.	Front stiffeners of lower tiers and of upper tiers when L is 160 m or greater	See <i>Pt 3, Ch 10 Welding and Structural Details</i>
2.	Front stiffeners of upper tiers when L is less than 160 m	May be unattached
3.	Side stiffeners of lower tiers where two or more tiers are fitted	Bracketed, unless stiffener modulus is increased by 20 per cent and ends are welded to the deck all round

4.	Side stiffeners if only one tier is fitted, and aft end stiffeners of after deckhouses on deck to which <i>D</i> is measured	See Pt 3, Ch 10 Welding and Structural Details
5.	Side stiffeners of upper tiers when <i>L</i> is 160 m or greater	See Pt 3, Ch 10 Welding and Structural Details
6.	Side stiffeners of upper tiers when <i>L</i> is less than 160 m	May be unattached
7.	Aft end stiffeners except as covered by item 4	May be unattached
8.	Exposed machinery and pump-room casings -Front stiffeners on amidship casings and all stiffeners on aft end casings which are situated on the deck to which <i>D</i> is measured	Bracketed
9.	All other stiffeners on exposed machinery and pump-room casings	6,5 cm ² of weld

Table 8.2.2 Thickness of deck plating

Position	Thickness of deck plating, in mm	
	<i>L</i> ≤ 100 m	<i>L</i> > 100 m
Top of first tier erection	$(5,5 + 0,02L)\sqrt{\frac{ks}{sb}}$	$7,5\sqrt{\frac{ks}{sb}}$
Top of second tier erection	$(5,0 + 0,02L)\sqrt{\frac{ks}{sb}}$	$7,0\sqrt{\frac{ks}{sb}}$
Top of third tier and above	$(4,5 + 0,02L)\sqrt{\frac{ks}{sb}}$ but not less than 5,0 mm	$6,5\sqrt{\frac{ks}{sb}}$

2.4 Deck longitudinals and beams

2.4.1 The section modulus of superstructure deck longitudinals and beams is to be in accordance with the requirements for location (2) in *Table 1.4.4 Cargo and accommodation deck longitudinals* and location (3) in *Table 1.4.5 Strength/weather, cargo and accommodation deck beams in Pt 4, Ch 1 General Cargo Ships*, using design heads not less than those specified in *Table 3.5.1* in Chapter 3 for superstructure decks.

2.4.2 Transverse deck beams in deckhouses and deck longitudinals other than as in *Pt 3, Ch 8, 2.7 Erections contributing to hull strength* are to have a section modulus, *Z*, not less than:

$$Z = 0,0048 h_2 s l_e^2 k \text{ cm}^3, \text{ but in no case less than:}$$

$$Z = 0,025s \text{ cm}^3$$

and the value of *h*₂, the load head, is to be taken as not less than:

- on first tier decks 0,9 m
- on second tier decks 0,6 m
- on third tier decks and above 0,45 m.

2.5 Deck girders and transverses

2.5.1 The section modulus of deck girders and transverses is to be in accordance with the requirements for location (1) in *Table 1.4.6 Deck girders, transverses and hatch beams in Pt 4, Ch 1 General Cargo Ships*, using design heads not less than those specified in *Table 3.5.1 Design heads and permissible cargo loadings* for superstructure decks.

2.6 Strengthening at ends and sides of erections

2.6.1 Web frames or partial bulkheads are to be fitted within poops and bridges that have large deckhouses or other erections above.

2.6.2 Web frames or equivalent strengthening are also to be arranged to support the sides and ends of large deckhouses.

2.6.3 These web frames should be spaced about 9 m apart and are to be arranged, where practicable, in line with watertight bulkheads below. Webs are also to be arranged in way of large openings, boats, davits and other points of high loading.

2.6.4 Arrangements are to be made to minimise the effect of discontinuities in erections. All openings cut in the sides are to be substantially framed and have well rounded corners. Continuous coamings or girders are to be fitted below and above doors and similar openings. House tops are to be strengthened in way of davits. Special care is to be taken to minimise the size and number of openings in the side bulkheads in the region of the ends of erections within 0,5L amidships. Account is to be taken of the high vertical shear loading which can occur in these areas.

2.6.5 Adequate support under the ends of erections is to be provided in the form of webs, pillars, diaphragms or bulkheads in conjunction with reinforced deck beams. At the corners of houses and in way of supporting structures, attention is to be given to the connection to the deck, and inserts or equivalent arrangements are generally to be fitted especially for erections that are effective in resisting vertical hull girder bending as defined in *Pt 3, Ch 3, 4.2 Collision bulkhead*.

2.6.6 The side plating of bridges having a length of 0,15L or greater is to be increased in thickness by 25 per cent at the ends of the structure, and is to be tapered into the upper deck sheerstrake. This plating is to be efficiently stiffened at the upper edge and supported by web plates not more than 1,5 m from the end bulkhead. Proposals for alternative arrangements, including the use of higher tensile steel, will be individually considered.

2.7 Erections contributing to hull strength

2.7.1 Where a long superstructure or deckhouse is fitted, extending within 0,5L amidships, the scantlings of the first tier deck plating and longitudinals may be required to be increased, *see also Pt 3, Ch 3, 3.4 Calculation of hull section modulus and Pt 3, Ch 4, 2.3 Open type ships*.

2.8 Unusual designs

2.8.1 Where superstructures or deckhouses are of unusual design, the strength is to be not less than that required by this Chapter for a conventional design.

■ **Section 3**
Aluminium erections

3.1 Scantlings

3.1.1 Where an aluminium alloy complying with *Ch 8 Aluminium Alloys* of the Rules for Materials (Part 2) is used in the construction of erections, the scantlings of these erections are to be increased (relative to those required for steel construction) by the percentages given in *Table 8.3.1 Percentage increase of scantlings*.

Table 8.3.1 Percentage increase of scantlings

Item	Percentage increase
Fronts, sides, aft ends, unsheathed deck plating	20
Decks sheathed in accordance with <i>Pt 3, Ch 8, 2.3 Deck plating 2.3.2</i>	10
Deck sheathed with wood, and on which the plating is fixed to the wood sheathing at the centre of each beam space	Nil
Stiffeners and beams	70
Scantlings of small isolated houses	Nil

3.1.2 The thickness, *t*, of aluminium alloy members is to be not less than:

$$t = 2,5 + 0,022d_w \text{ mm but need not exceed 10 mm}$$

where

d_w = depth of the section, in mm.

3.1.3 The minimum moment of inertia, I , of aluminium alloy stiffening members is to be not less than:

$$I = 5,25Z l_e \text{ cm}^4$$

Where l_e is the effective length of the member in metres, as defined in *Pt 3, Ch 8, 1.2 Symbols 1.2.1*, and Z is the section modulus of the stiffener and attached plating calculated using the formulae in *Pt 3, Ch 8, 2.2 Stiffeners and their connections 2.2.1* and *Pt 3, Ch 8, 2.4 Deck longitudinals and beams 2.4.2*, as applicable, taking k as 1.

3.2 Bimetallic joints

3.2.1 Where aluminium erections are arranged above a steel hull, details of the arrangements in way of the bimetallic connections are to be submitted.

Section 4 Forecastles

4.1 Construction

4.1.1 Side plating and framing of forecastles are to comply with the requirements of *Pt 3, Ch 5, 3 Shell envelope plating* and *Pt 3, Ch 5, 4 Shell envelope framing* respectively. The end plating and its stiffening are to comply with the requirements of *Pt 3, Ch 8, 2.1 Thickness of bulkhead and side plating 2.1.1* and *Pt 3, Ch 8, 2.2 Stiffeners and their connections 2.2.1* respectively.

4.1.2 The bow height and the extent of the forecastle are to comply with the requirements of *Pt 3, Ch 3, 6 Minimum bow heights, reserve buoyancy and extent of forecastle*.

4.1.3 The thickness, t , of forecastle deck plating is to be not less than:

$$t = (6 + 0,017L) \sqrt{\frac{ks}{s_b}} \text{ mm}$$

4.1.4 Deck longitudinals and beams are to comply with *Pt 3, Ch 5, 2.3 Deck stiffening*, using a head of 1,8 m forward of 0,075L and 1,5 m between 0,12L and 0,075L.

4.1.5 Girders, transverses and pillars are to be in accordance with *Pt 3, Ch 5, 2.4 Deck supporting structure*, and the depth of the girder or transverse is to be not less than twice that of the beam or longitudinal supported.

Section 5 Bulwarks, guard rails and other means for the protection of crew

5.1 General requirements

5.1.1 Bulwarks or guard rails are to be provided around all exposed decks. Bulwarks or guard rails are to be not less than 1,0 m in height measured above sheathing, and are to be constructed as required by this Section. Consideration will be given to cases where this height would interfere with the normal operation of the ship.

5.1.2 The freeing arrangements in bulwarks are to be in accordance with *Pt 3, Ch 8, 5.3 Freeing arrangements*.

5.1.3 Guard rails fitted on superstructure and freeboards decks are to have at least three courses. The opening below the lowest course of guard rails is not to exceed 230 mm. The other courses are to be spaced not more than 380 mm apart. In the case of ships with rounded gunwales, the guard rail supports are to be placed on the flat of the deck. In other locations, guard rails with at least two courses are to be fitted.

5.1.4 Guard rails are to be fitted with fixed, removable or hinged stanchions fitted no more than 1,5 m apart. Removable or hinged stanchions shall be capable of being locked in the upright position.

5.1.5 At least every third stanchion is to be supported by a stay. In lieu of this, flat steel stanchions shall be of increased breadth as given in *Figure 8.5.1 Support of stanchions*, and aligned with a member below deck unless the deck plating thickness exceeds 20 mm. Guard rail stanchions of increased breadth are to be welded to the deck with double continuous fillet weld with a minimum leg size of 7 mm or in compliance with a standard recognised by LR.

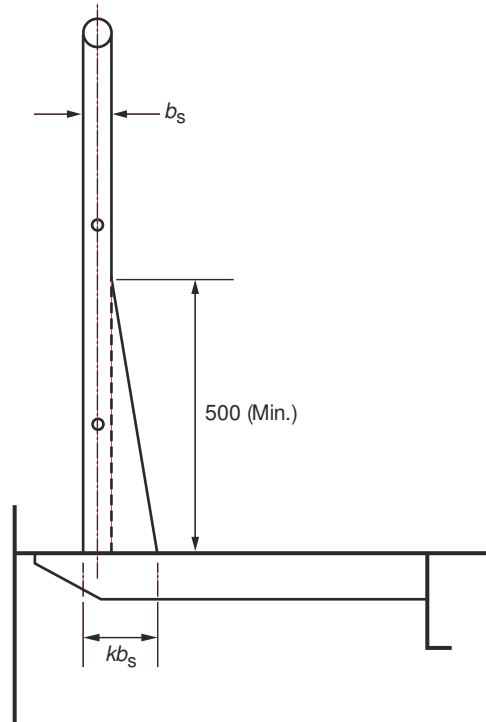

In lieu of at least every third stanchion supported by stay, alternatively:

- (a) at least every third stanchion shall be of increased breadth: $kb_s = 2,9b_s$
- (b) at least every second stanchion shall be of increased breadth: $kb_s = 2,4b_s$
- (c) every stanchion shall be of increased breadth: $kb_s = 1,9b_s$

where

b_s breadth of normal stanchion as specified in an appropriate standard recognised by LR

Stanchions with increased breadth are to be aligned with members below deck, minimum 100 x 12 flat bar welded to deck by double continuous fillet weld. Stanchions with increased breadth need not be aligned with under deck structure for deck plating exceeding 20 mm.

Figure 8.5.1 Support of stanchions

5.1.6 Where necessary for the normal operation of the ship, steel wire ropes may be accepted in lieu of guard rails. Wires are to be made taut by means of turnbuckles. Chains are only permitted in short lengths in way of access openings.

5.1.7 Satisfactory means, in the form of guard rails, life-lines, handrails, gangways, underdeck passageways or other equivalent arrangements, are to be provided for the protection of the crew in getting to and from their quarters, the machinery space and all other parts used in the necessary work of the ship in accordance with *Table 8.5.1 Protection of crew*.

5.1.8 Where gangways on a trunk are provided by means of a stringer plate fitted outboard of the trunk side bulkheads (port and starboard), each gangway is to be a solid plate, effectively stayed and supported, with a clear walkway at least 450 mm wide,

at or near the top of the coaming, with guard rails complying with *Pt 3, Ch 8, 5.1 General requirements 5.1.3* and hatch cover securing appliances accessible from the gangway.

5.1.9 Where permitted by the National Authority, gangways or walkways may be omitted on ships engaged on protected or extended protected water service. However, life-lines are to be provided on tankers and flush deck ships, or where the cargo hatch coamings are less than 600 mm high.

5.1.10 For a Type 'A' ship with freeboards assigned greater than, or equal to, Type 'B', a life-line may be provided in lieu of a walkway.

5.2 Bulwark construction

5.2.1 Plate bulwarks are to be stiffened by a strong rail section and supported by stays from the deck. The spacing of these stays forward of $0,07L$ from the forward perpendicular is to be not more than 1,2 m on Type 'A', Type 'B-60' and Type 'B-100' ships (as defined in *Pt 3, Ch 11, 1.1 Application*), and not more than 1,83 m on other Types. Elsewhere, bulwark stays are to be not more than 1,83 m apart. Where bulwarks are cut to form a gangway or other opening, stays of increased strength are to be fitted at the ends of the openings. Bulwarks are to be adequately strengthened in way of eyeplates for cargo gear, and in way of mooring pipes the plating is to be doubled or increased in thickness and adequately stiffened.

5.2.2 Bulwarks should not be cut for gangway or other openings near the breaks of superstructures, and are also to be arranged to ensure their freedom from main structural stresses. See shell plating in appropriate Chapters.

5.2.3 The section modulus, Z , at the bottom of the bulwark stay is to be not less than:

$$Z = (33,0 + 0,44L) h^2 s \text{ cm}^3$$

where

h = height of bulwark from the top of the deck plating to the top of the rail, in metres

s = spacing of the stays, in metres, in accordance with *Pt 3, Ch 8, 5.2 Bulwark construction 5.2.1*

L = length of ship, in metres (as defined in *Pt 3, Ch 1, 6.1 Principal particulars*), but to be not greater than 100 m.

5.2.4 In the calculation of the section modulus, only the material connected to the deck is to be included. The bulb or flange of the stay may be taken into account where connected to the deck, and where, at the ends of the ship, the bulwark plating is connected to the sheerstrake, a width of plating not exceeding 600 mm may also be included. The free edge of the stay is to be stiffened.

5.2.5 Bulwark stays are to be supported by, or to be in line with, suitable underdeck stiffening, which is to be connected by double continuous fillet welds in way of the bulwark stay connection.

5.2.6 It should be noted that the above requirements do not allow for any loading from deck cargoes.

5.3 Freeing arrangements

5.3.1 The requirements of *Pt 3, Ch 8, 5.3 Freeing arrangements 5.3.2* to *Pt 3, Ch 8, 5.3 Freeing arrangements 5.3.11* apply to ships of Type 'B'. Additional requirements applicable to ships of Type 'A', Type 'B-100' and Type 'B-60' are indicated in *Pt 3, Ch 8, 5.3 Freeing arrangements 5.3.18* and *Pt 3, Ch 8, 5.3 Freeing arrangements 5.3.20*. The ship Types are as defined in *Pt 3, Ch 11, 1.1 Application*.

5.3.2 Where bulwarks on the weather portions of freeboard or superstructure decks form wells, ample provision is to be made for rapidly freeing the decks of large quantities of water by means of freeing ports, and also for draining them.

5.3.3 The minimum freeing area on each side of the ship, for each well on the freeboard deck or raised quarterdeck, where the sheer in the well is not less than the standard sheer required by the *Load Lines, 1966/1988 - International Convention on Load Lines, 1966, as Amended by the Protocol of 1988*, is to be derived from the following formulæ:

(a) where the length, l , of the bulwark in the well is 20 m or less:

$$\text{area required} = 0,7 + 0,035 l \text{ m}^2$$

(b) where the length, l , exceeds 20 m:

$$\text{area required} = 0,07 l \text{ m}^2$$

l need not be taken greater than $0,7L_L$, where L_L is the length of the ship as defined in *Pt 3, Ch 1, 6.1 Principal particulars*.

5.3.4 If the average height of the bulwark exceeds 1,2 m or is less than 0,9 m, the freeing area is to be increased or decreased, respectively, by 0,004 m² per metre of length of well for each 0,1 m increase or decrease in height respectively.

5.3.5 The minimum freeing area for each well on a first tier superstructure is to be half the area calculated from *Pt 3, Ch 8, 5.3 Freeing arrangements 5.3.3*.

5.3.6 Two-thirds of the freeing port area required is to be provided in the half of the well nearest to the lowest point of the sheer curve.

5.3.7 When the deck has little or no sheer, the freeing area is to be spread along the length of the well.

Table 8.5.1 Protection of crew

Ship Type	Location in ship	Assigned Summer Freeboard, in mm	Acceptable arrangements according to type of freeboard assigned			
			Type A	Type (B-100)	Type (B-60)	Type (B & B +)
Oil tankers, chemical tankers and gas carriers (see <i>Pt 3, Ch 8, 1.1 Application 1.1.5</i>)	1.1 Access to bow	$\leq (A_f + H_s)$	a	a	a	a
	1.1.1 Between poop and bow or		e	e	e	e
	1.1.2 Between a deckhouse containing living accommodation or navigation equipment, or both, and bow, or		f(1)	f(1)	f(1)	f(1)
	1.1.3 In the case of a flush deck vessel, between crew accommodation and the forward ends of ship	$>(A_f + H_s)$		a e f(1) f(5)		
1.2 Access to after end	In the case of a flush deck vessel, between crew accommodation and the after end of ship	As required in item 2.2.4 in <i>Pt 3, Ch 8, 5.3 Freeing arrangements 5.3.7</i> for other types of ships				

Other ship type	2.1 Access to midship quarters 2.1.1 Between poop and bridge, or	≤ 3000 mm	a b e	a b e	a b c(1) e f(1)	a b c(1) c(2) d(1) d(2) d(3) e f(1) f(2) f(4)
	2.1.2 Between poop and deckhouse containing living accommodation or navigation equipment, or both	> 3000 mm	a b e	a b e	a b c(1) c(2) e f(1) f(2)	
	2.2 Access to ends 2.2.1 Between poop and bow (if there is no bridge), 2.2.2 Between bridge and bow, or	≤ 3000 mm	a b c(1) e f(1)	a b c(1) c(2) e f(1) f(2)	a b c(1) c(2) e f(1) f(2)	a b c(1) c(2) d(1) d(2) d(3) e f(1) f(2) f(4)
	2.2.3 Between a deckhouse containing living accommodation or navigation equipment, or both, and bow, or 2.2.4 In the case of a flush deck vessel, between crew accommodation and the forward and after ends of ship	> 3000 mm	a b c(1) d(1) e f(1)	a b c(1) d(1) d(2) e f(1) f(2)	a b c(1) c(2) d(1) d(2) d(3) e f(1) f(2) f(4)	

Symbols

A_f = the minimum summer freeboard calculated as Type A ship regardless of type freeboard actually assigned

H_s = the standard height of superstructure as defined in *International Convention on Load Lines*, Regulation 33

Acceptable arrangements:

Acceptable arrangements referred to in the Table are defined as follows:

a A well lighted and ventilated under-deck passageway (clear opening 0,8 m wide, 2 m high) as close as practicable to the freeboard deck, connecting and providing access to the locations in question.

b A permanent and efficiently constructed gangway fitted at or above the level of the superstructure deck on or as near as practicable to the centreline of the ship, providing a continuous platform at least 0,6 m in width and a non-slip surface, with guard rails extending on each side throughout its length. Guard-rails shall be at least 1 m high with courses as required in *Pt 3, Ch 8, 5.1 General requirements*, and supported by stanchions spaced not more than 1,5 m; a foot-stop shall be provided.

c A permanent walkway at least 0,6 m in width fitted at freeboard deck level consisting of two rows of guard-rails with stanchions spaced not more than 3 m. The number of courses of rails and their spacing are to be as required by *Pt 3, Ch 8, 5.1 General requirements*. On Type B ships, hatchway coamings not less than 0,6 m in height may be regarded as forming one side of the walkway, provided that between the hatchways two rows of guard rails are fitted.

d A 10 mm minimum thickness diameter wire rope life-line supported by stanchions about 10 m apart, or a single hand rail or wire rope attached to hatch coamings, continued and adequately supported between hatchways.

e A permanent and efficiently constructed gangway fitted at or above the level of the superstructure deck on or as near as practicable to the centreline of the ship:

- located so as not to hinder easy access across the working areas of the deck;
- providing a continuous platform at least 1,0 m in width;
- constructed of fire resistant and non-slip material;
- fitted with guard rails extending on each side throughout its length; guard rails should be at least 1,0 m high with courses as required by Regulation 25(3) and supported by stanchions spaced not more than 1,5 m;
- provided with a foot stop on each side;
- having openings, with ladders where appropriate, to and from the deck. Openings should not be more than 40 m apart;
- having shelters of substantial construction set in way of the gangway at intervals not exceeding 45 m if the length of the exposed deck to be traversed exceeds 70 m. Every such shelter should be capable of accommodating at least one person and be so constructed as to afford weather protection on the forward port and starboard sides.

f A permanent and efficiently constructed walkway fitted at freeboard deck level on or as near as practicable to the centre line of the ship having the same specifications as those for a permanent gangway listed in (e) except for foot-stops. On Type B ships (certified for the carriage of liquids in bulk), with a combined height of hatch coaming and fitted hatch cover of together not less than 1 m in height the hatchway coamings may be regarded as forming one side of the walkway, provided that between the hatchways two rows of guard rails are fitted.

Alternative transverse locations for c, d and f:

(1) At or near centreline of ship; or

fitted on hatchways at or near centreline of ship.

(2) Fitted on each side of the ship.

(3) Fitted on one side of the ship, provision being made for fitting on either side.

(4) Fitted on one side of the ship only.

(5) Fitted on each side of hatchways as near to the centreline as practicable.

NOTES

Note 1. In all cases where wire ropes are fitted, adequate devices are to be provided to ensure their tautness.

Note 2. Wire ropes may only be accepted in lieu of guard rails in special circumstances and then only in limited lengths.

Note 3. Lengths of chain may only be accepted in lieu of guard rails if fitted between two fixed stanchions.

Note 4. Where stanchions are fitted, every third stanchion is to be supported by a bracket or stay.

Note 5. Removable or hinged stanchions shall be capable of being locked in the upright position.

Note 6. A means of passage over obstructions, if any, such as pipes or other fittings of a permanent nature, should be provided.

Note 7. Generally, the width of the gangway or deck-level walkway should not exceed 1,5 m.

5.3.8 In ships with no sheer the freeing area as calculated from *Pt 3, Ch 8, 5.3 Freeing arrangements 5.3.3* is to be increased by 50 per cent. Where the sheer is less than the standard, the percentage is to be obtained by linear interpolation.

5.3.9 Where the length of the well is less than 10 m, or where a deckhouse occupies most of the length, the freeing port area will be specially considered but in general need not exceed 10 per cent of the bulwark area.

5.3.10 Where it is not practical to provide sufficient freeing port area in the bulwark, particularly in small ships, credit can be given for bollard and fairlead openings where these extend to the deck.

5.3.11 Where a ship fitted with bulwarks has a continuous trunk, or hatch side coamings that are continuous, or substantially continuous, the minimum freeing area is to be not less than 20 per cent of the total bulwark area where the width of trunk or hatchway is $0,4B$ or less, and not less than 10 per cent of the total bulwark area when the width of the trunk or hatch is $0,75B$ or greater. The freeing area required for an intermediate width of trunk or hatch is to be obtained by linear interpolation.

5.3.12 Where the trunk referred to in *Pt 3, Ch 8, 5.3 Freeing arrangements 5.3.11* or its equivalent is included in the calculation of freeboard, open rails are to be fitted for at least 50 per cent of the length of the exposed part of the weather deck. Alternatively,

if a continuous bulwark is fitted, the minimum freeing area is to be at least 33 per cent of the bulwark area. The freeing area is to be placed in the lower part of the bulwark.

5.3.13 Where a deckhouse has a breadth less than 80 per cent of the beam of the ship, or the width of the side passageways exceeds 1,5 m, the arrangement is considered as one well. Where a deckhouse has a breadth equal to or more than 80 per cent of the beam of the ship, or the width of the side passageways does not exceed 1,5 m, or when a screen bulkhead is fitted across the full breadth of the ship, this arrangement is considered as two wells, before and abaft the deckhouse.

5.3.14 Suitable provision is also to be made for the rapid freeing of water from recesses formed by superstructures, deckhouses and deck cargo arrangements, etc. in which water may be shipped and trapped. Deck gear, particularly on fishing vessels, is not to be stowed in such a manner as to obstruct unduly the flow of water to freeing ports.

5.3.15 The lower edges of freeing ports are to be as near to the deck as practicable, and should not be more than 100 mm above the deck.

5.3.16 Where freeing ports are more than 230 mm high, vertical bars spaced 230 mm apart may be accepted as an alternative to a horizontal rail to limit the height of the freeing port.

5.3.17 Where shutters are fitted, the pins or bearings are to be of a non-corrodible material, with ample clearance to prevent jamming. The hinges are to be within the upper third of the port. Shutters are not to be fitted with securing appliances.

5.3.18 Ships of Type 'A' and Type 'B-100' are to have open rails for at least half the length of the exposed part of the weather deck. Alternatively, if a continuous bulwark is fitted, the minimum freeing area is to be at least 33 per cent of the total area of the bulwark. The freeing area is to be placed in the lower part of the bulwark.

5.3.19 Where superstructures are connected by trunks, open rails are to be fitted for the whole length of the exposed part of the freeboard deck.

5.3.20 Ships of Type 'B-60' are to have a minimum freeing area of at least 25 per cent of the total area of the bulwark. The freeing area is to be placed in the lower part of the bulwark.

5.3.21 Gutter bars greater than 300 mm in height fitted on the weather decks of tankers are to be treated as bulwarks and freeing ports arranged as required by this Section. Closures for use during loading and discharge operations are to be arranged in such a way that jamming cannot occur while at sea.

5.3.22 In ships having superstructures which are open at either or both ends to wells formed by bulwarks on the open deck, adequate provision for freeing the open spaces are to be provided as follows:

The freeing port area, A_w for the open well:

$$A_w = (0,07l_w + A_c)(S_c)\left(\frac{0,5h_s}{h_w}\right)$$

The freeing port area, A_s for the open superstructure:

$$A_s = (0,07l_t)(S_c)\left(\frac{b_o}{l_t}\left(1 - \left(\frac{l_w}{l_t}\right)^2\right)\right)\left(\frac{0,5h_s}{h_w}\right)$$

where

l_w = the length of the open deck enclosed by bulwarks, in metres

l_s = the length of the common space within the open superstructure, in metres

l_t = $l_w + l_s$ but if 20 m or less then the freeing area is to be calculated in accordance with Pt 3, Ch 8, 5.3 *Freeing arrangements* 5.3.3

S_c = sheer correction factor, maximum 1,5 as defined in Pt 3, Ch 8, 5.3 *Freeing arrangements* 5.3.8

b_o = breadth of openings in the end bulkhead of the enclosed superstructure, in metres

h_w = distance of the well deck above the freeboard deck, in metres

h_s = one standard superstructure height, see Pt 3, Ch 8, 1.3 *Definition of tiers* 1.3.2

h_b = actual height of the bulwark, in metres

A_c = bulwark height correction factor taken as;

where

$$= 0 \text{ for bulwarks between } 0,9 \text{ and } 1,2 \text{ m in height}$$

$$= l_w \left(\frac{(h_b - 1,2)}{0,1} \right) (0,004) \text{ m}^2 \text{ for bulwarks of height greater than } 1,2 \text{ m, and}$$

$$= l_w \left(\frac{(h_b - 0,9)}{0,1} \right) (0,004) \text{ m}^2 \text{ for bulwarks of height less than } 0,9 \text{ m.}$$

To adjust the freeing port area for the distance of the well deck above the freeboard deck, for decks located more than $0,5h_s$ above the freeboard deck, multiply by the factor $0,5(h_s/h_w)$.

5.4 Free flow area

5.4.1 The effectiveness of the freeing port area in bulwarks of vessels not fitted with a continuous deck obstruction, depends on the free flow across the deck.

5.4.2 The free flow area is the net total longitudinal area of the transverse passageways or gaps between hatchways and superstructures or deckhouses, due account being made for any obstructions such as equipment or other fittings. The height of passageways or gaps used in the calculation of the area is the height of the bulwark.

5.4.3 The provision of freeing area in bulwarks should be related to the net free flow area as follows:

- (a) If the free flow area is equal to, or greater than the freeing port area calculated from Pt 3, Ch 8, 5.3 Freeing arrangements 5.3.11 when the hatchway coamings are continuous, then the minimum freeing area calculated from Pt 3, Ch 8, 5.3 Freeing arrangements 5.3.3 is sufficient.
- (b) If the free flow area is less than the freeing port area calculated from Pt 3, Ch 8, 5.3 Freeing arrangements 5.3.3, then the minimum freeing area is to be that calculated from Pt 3, Ch 8, 5.3 Freeing arrangements 5.3.11.
- (c) If the free flow area is less than the freeing port area derived from (a) but greater than that derived from Pt 3, Ch 8, 5.4 Free flow area 5.4.3, the minimum freeing area, F , in the bulwark is to be obtained from the following formula:

$$F = F_1 + F_2 - f_p \text{ m}^2$$

where:

f_p = total net area of passages and gaps between hatchways, superstructures and deckhouses (the free flow area)

F_1 = minimum area from Pt 3, Ch 8, 5.3 Freeing arrangements 5.3.3

F_2 = minimum area from Pt 3, Ch 8, 5.3 Freeing arrangements 5.3.11

5.5 Special requirements for tugs and offshore supply ships

5.5.1 In tugs and offshore supply ships where there is a recess at the after end of the forecastle for the towing winch, the freeing port area in way of the recess is to be calculated as follows:

B = breadth of ship

b = breadth of recess

L = length of well

l = mean length of recess

a = freeing area for well length L

Freeing port area in way of recess:

$$A = a \frac{l}{L}$$

Reduction due to breadth of recess:

$$A_1 = A \frac{b}{B}$$

Reduce A_1 by 25 per cent for winch area:

$$A_2 = 0,75 A_1$$

= required freeing port area each side in way of the recess

Where the winch is enclosed in a non-weathertight compartment freeing ports are not required but adequate drainage by means of scuppers is to be provided.

Section

- 1 **General**
- 2 **Timber deck cargoes**
- 3 **Decks loaded by wheeled vehicles**
- 4 **Movable decks**
- 5 **Helicopter landing areas**
- 6 **Lifting appliances and support arrangements**
- 7 **Bottom strengthening for loading and unloading aground**
- 8 **Strengthening for regular discharge by heavy grabs**

■ *Section 1*
General

1.1 Application

1.1.1 The requirements of this Chapter are to be taken in conjunction with the Chapters of *Pt 3 Ship Structures (General)* and *Pt 4 Ship Structures (Ship Types)* applicable to the particular ship type.

1.2 Symbols

1.2.1 The following symbols and definitions are applicable to this Chapter:

k = higher tensile steel factor, see *Pt 3, Ch 2, 1.2 Steel*

l = overall length, of the stiffening member, in metres

l_e = effective length, in metres, of the stiffening member, measured between span points, see *Pt 3, Ch 3, 3.3 Determination of span point*

s = spacing, of stiffeners, in mm

B = moulded breadth of ship, in metres, see *Pt 3, Ch 1, 6.1 Principal particulars*

L = length of ship, in metres, see *Pt 3, Ch 1, 6.1 Principal particulars*

Z = section modulus of the stiffening member, in cm^3 , see *Pt 3, Ch 3, 3.2 Geometric properties of section*

1.2.2 Other symbols are defined in the appropriate Section.

■ *Section 2*
Timber deck cargoes

2.1 Application

2.1.1 Where timber load lines are to be assigned, the full requirements of this Section are to be complied with, and the ship will be eligible to be assigned the notation 'timber deck cargoes'.

2.1.2 In other cases, proposals to carry timber deck cargoes which will impose on the weather deck a mean cargo loading in excess of 8,5 kN/m² (0,865 tonne-f/m²) will be considered on the basis of these requirements. In particular, the requirements of *Pt 3, Ch 9, 2.9 Longitudinal strength to Pt 3, Ch 9, 2.12 Direct calculations* are to be complied with.

2.2 Symbols and definitions

2.2.1 The term 'timber deck cargo' means a cargo of timber carried on an uncovered part of the freeboard or superstructure deck. The term does not include wood pulp or similar cargo.

2.2.2 The symbols used in this Section are defined as follows:

C = mean stowage rate, in m³/tonne, of the timber deck cargo, making allowance for normal battens, etc.

h = the height, in metres, to which the timber deck cargo is to be stowed, measured vertically from the deck or hatch cover as applicable.

2.2.3 Other symbols are defined in *Pt 3, Ch 9, 1.2 Symbols*.

2.3 General

2.3.1 Attention is drawn to the requirements of the *International Convention for the Safety of Life at Sea, 1974, Chapter VI*, as amended, the *International Load Line Convention, 1966*, concerning timber deck cargoes, and its 1988 Protocol, and to National Regulations. Attention is also drawn to *IMO Resolution A.1048(27) – Code of Safe Practice for Ships Carrying Timber Deck Cargoes, 2011 (2011 TDC Code) – (Adopted on 30 November 2011)*.

2.3.2 Timber deck cargoes are to be loaded, stowed and secured throughout the voyage, in accordance with the Cargo Securing Manual approved by the Flag Administration as required by *Chapter VI - Carriage of cargoes and oil fuels*.

2.3.3 Each cargo securing arrangement for timber deck cargoes detailed in the ship's Cargo Securing Manual is to be documented by a lashing plan that shows the following:

- (a) maximum cargo weight for which the arrangement is designed;
- (b) maximum stowage height;
- (c) required number and strength of blocking devices and lashings, as applicable;
- (d) required pre-tension in lashings;
- (e) other cargo properties of importance for the securing arrangement, such as friction, rigidity of timber packages;
- (f) illustrations of all securing items that might be used;
- (g) any restrictions regarding maximum accelerations, weather criteria, restricted sea areas and for non-winter conditions only;
- (h) the walkway/life-line arrangements; and
- (i) stowage arrangement, which is to be in accordance with *Pt 3, Ch 9, 2.7 Stowage*.

The Cargo Securing Manual is to be submitted for approval, and a copy placed on board the ship.

2.3.4 All timber deck cargoes must be compactly stowed, lashed and secured. Friction alone is not deemed sufficient and such methods are not endorsed by Lloyd's Register.

2.3.5 Timber freeboards cannot be used where wood pulp is being carried as the deck cargo. Packaged timber (timber which has been prelash) may be carried on deck with the ship at its timber freeboards.

2.3.6 Type 'B-60' ships may have timber freeboards assigned based on ordinary Type 'B' freeboards.

2.3.7 Timber freeboards are not appropriate for ships which are assigned freeboards from a second deck. However, where the maximum geometric upper deck draught is restricted, a restricted timber draught may be assigned.

2.3.8 It is the Master's responsibility to ensure loose gear (e.g. uprights, wire lashings and life-lines) are supplied and fitted onboard in accordance with the approved timber deck cargo loading and lashing plan when the ship is carrying timber deck cargoes. However, it is not a requirement that loose gear remains permanently on board a ship assigned timber freeboards.

2.4 Arrangements

2.4.1 Double bottom tanks within the midship half-length are to have adequate longitudinal subdivision.

2.4.2 A forecastle of at least standard height of a superstructure, defined by Regulation 33 of the International Load Line Convention, as amended, and of length at least 0,07L is to be fitted. In addition, in ships of less than 100 m in length, a poop of at

least standard height, or a raised quarterdeck with a deckhouse or strong steel hood of at least the same total height, is to be fitted.

2.5 Uprights

2.5.1 Uprights are to be of adequate strength but are not to exceed the strength of the bulwark. Where timber uprights are used, it is the responsibility of the Master to use timber which is of a type and grade which has proved satisfactory for the purpose. Where a timber load line is not assigned and uprights are not connected to the bulwark, uprights are to be of adequate strength but need not relate to that of the bulwark, see *Pt 3, Ch 9, 2.1 Application 2.1.2*.

2.5.2 Uprights are to be used for all timber deck cargoes with the exception that, where only packaged timber is to be carried, uprights may be omitted, depending on racking strength and not including uprights or stoppers (low uprights) situated either side of hatch covers.

2.5.3 The spacing of the uprights is to be suitable for the length and character of the timber to be carried but is not to exceed 3 m.

2.5.4 Each upright is to extend above the top of the cargo and be fitted with a strap or bracket support at the top of the bulwark to hold it upright whilst loading.

2.5.5 Strong permanent bulwarks, or efficient rails of specially strong construction, are to be fitted. Steel bulwarks, along with guard rails and stanchions, are acceptable as supports for uprights, provided substantial sockets are built for each upright.

2.5.6 Deck sockets are to be of a size to suit the dimensions of the uprights and are to be not less than 100 mm in depth with drainage provided. They are to be efficiently connected to the hull structure. A locking pin or wedge is to be provided to prevent the upright lifting out of the socket.

2.6 Lashings

2.6.1 The timber deck cargo is to be secured along its length by independent top over lashings.

2.6.2 The spacing of top over lashings is to be determined by the height of the cargo above the deck or by the type of timber, see *Pt 3, Ch 9, 2.6 Lashings 2.6.3* and *Pt 3, Ch 9, 2.6 Lashings 2.6.4*:

- (a) For heights not more than 2,5 m, the spacing is to be not more than 3m.
- (b) For heights above 2,5 m, the spacing is to be not more than 1,5 m.

2.6.3 Where only packaged timber is to be carried, and uprights are omitted, see 2.5.2, lashings are to be spaced not more than 1, 1,5 m apart.

2.6.4 Round wood timber deck cargo is to be secured throughout its length by top over lashings spaced not more than 1,5 m apart.

2.6.5 At the fore and aftermost ends of each continuous timber deck stow, the spacing of the lashings determined from *Pt 3, Ch 9, 2.6 Lashings 2.6.2*, *Pt 3, Ch 9, 2.6 Lashings 2.6.3* or *Pt 3, Ch 9, 2.6 Lashings 2.6.4* is to be halved.

2.6.6 The spacing of lashings is to be such that lashings are positioned as close as practicable to the ends of each continuous timber deck stow.

2.6.7 Round wood timber deck cargo stowed over and above hatches, in addition to *Pt 3, Ch 9, 2.6 Lashings 2.6.4*, is to be further secured by a system of athwartship lashings connecting respective port and starboard uprights at three quarters of the height of the stow. If the height of the hatch cover over which the cargo is stowed is less than 2 m, a further athwartship lashing is to be installed 1 m above the hatch cover.

2.6.8 Lashings and fittings must not:

- (a) have a breaking strength of less than 133 kN;
- (b) elongate more than 5 per cent at 80 per cent of the breaking strength;
- (c) show any permanent deformation at less than 40 per cent of the breaking strength.

2.6.9 Where timber is in lengths of less than 3,6 m, the spacing of lashings is to be reduced, or other suitable provisions made to suit the length of the timber.

2.6.10 Open hooks, which may loosen if the lashing becomes slack, are not to be used in securing arrangements for timber deck cargoes and web lashing is not to be used in combination with chain or wire lashing.

2.6.11 Slip hooks or other appropriate methods may be used for quick and safe adjustment of lashings. Pelican hooks, when used, are to be moused.

2.6.12 Corner protectors are to be used to prevent lashings from cutting into the cargo and to protect lashings from damage at sharp corners.

2.6.13 Every lashing is to be provided with a tightening device or system, situated so that it can be safely and efficiently operated when required. The magnitude of the components of the resolved load produced by the tightening device or system is not to be less than:

- (a) 27 kN in the horizontal; and
- (b) 16 kN in the vertical.

2.6.14 Once the lashings are secured, the tightening device or system is to have not less than half the tightening capacity available for further use.

2.6.15 If wire rope clips are used to make a joint in a wire lashing, the following conditions are to be observed to avoid a significant reduction in strength:

- (a) the number and size of rope clips utilised are to be in proportion to the diameter of the wire rope and no fewer than three, each spaced at intervals of not less than 150 mm.
- (b) the saddle portion of the clip is to be applied to the live load segment; and
- (c) rope clips are to be initially tightened so that they visibly compress the wire rope and are subsequently to be re-tightened after the lashing has been stressed.

2.6.16 Bulldog grips are only suitable for a standard wire rope of right-hand lay having six strands. Such grips are not to be used for wire rope of left-hand lay or different construction.

2.6.17 Rounded angle pieces of suitable material and design are to be used along the upper outboard edge of the stow to bear the stress and permit free reeving of the lashings.

2.6.18 Eye plates are to be of substantial construction, effectively connected to the hull structure, and placed at intervals determined from *Pt 3, Ch 9, 2.6 Lashings 2.6.2* to *Pt 3, Ch 9, 2.6 Lashings 2.6.5*. The distance from a superstructure end bulkhead to the first eye plate and lashing is to be not more than 2 m.

2.7 Stowage

2.7.1 The stowage arrangements are to be detailed within the lashing plan, see *Pt 3, Ch 9, 2.3 General 2.3.3*.

2.7.2 Timber deck cargoes are to extend over at least the entire available length, which is the total length of the well or wells between superstructures. Where there is no limiting superstructure at the after end, the timber is to extend at least to the after end of the aftermost hatchway.

2.7.3 The timber deck cargo is to extend athwartships as close as possible to the ship's side, due allowance being made for obstructions, provided any gap thus created at the side of the ship does not exceed a mean of four per cent of the breadth.

2.7.4 The timber is to be stowed as solidly as possible to at least the standard height of a superstructure other than a raised quarter deck. It is not to interfere in any way with the safe navigation and necessary work of the ship.

2.7.5 On a ship within a seasonal winter zone in winter, the height of the deck cargo above the deck exposed to weather must not exceed one third of the extreme breadth of the ship.

2.7.6 Cargo which overhangs hatch coamings or other structures in the longitudinal direction by more than a third of their individual or packed length is to be supported at the outer end by other cargo stowed on deck or by structure of adequate strength.

2.8 Safety arrangements

2.8.1 If there is no convenient passage on or below the deck of the ship, a walkway is to be provided over the timber deck cargo. This walkway is either to be:

- (a) At, or near, the centreline of the ship, consisting of two sets of guard wires, spaced 1 m apart, each with more than three courses of wire. The opening below the lowest course is not to exceed 230 mm; the remaining courses are to be spaced not more than 380 mm apart to a height of at least 1 m above the timber deck cargo. The guard wires are to be secured to stanchions. The stanchions are to be not more than 3 m apart, and these are to be secured to the timber cargo by spikes, or other equivalent means.

- (b) Alternatively, where uprights are used, guard wires, spaced vertically not more than 330 mm apart, are to be secured to the uprights along the length of the timber deck cargo on both port and starboard sides to a height of not less than 1 m above the cargo. A wire life-line is also to be fitted at the centreline of the ship, adequately supported by stanchions spaced not more than 10 m apart.

A safe walking surface, not less than 600 mm in width, is to be fitted over the cargo and effectively secured to the top of it in line with the walkway or adjacent to the life-line. All lines are to be taut using tightening devices.

2.8.2 Safe access is to be provided to the top of the timber deck cargo by means of properly constructed ladders, steps or ramps fitted with guard lines or handrails.

2.8.3 All openings in the weather deck are to be capable of being properly closed and secured tight. Ventilators, air pipes and other fittings enclosing openings are to be efficiently protected against damage.

2.8.4 Access hatches, vents, air pipes, fire hydrants, hoses, valve operating positions, sounding pipes and other essential equipment are to be clearly marked and left accessible.

2.9 Longitudinal strength

2.9.1 The proposed timber deck loading conditions are to be taken into account in the longitudinal strength calculations see *Pt 3, Ch 4 Longitudinal Strength*, and details are to be included in the ship's Loading Manual.

2.10 Deck loading and scantlings

2.10.1 In general, the stowage rate, C , of timber deck cargoes is to be taken as:

- (a) for round timber and logs:

$$C = 2,1 \text{ m}^3/\text{tonne}$$

- (b) for packaged sawn timber:

$$C = 1,45 \text{ m}^3/\text{tonne}.$$

These values are based on the total volume occupied by the cargo, including normal battens, etc. measured from bulwark to bulwark, and deck, or hatch cover, to top of cargo.

2.10.2 Where it is proposed to store timber more densely than that corresponding to the above values, the appropriate value of C is to be used.

2.10.3 The load height, h , of the cargo at any position is to be determined from the overall heights of cargo stowage as supplied by the Shipbuilder. Where the height of cargo varies, a mean effective load height is to be adopted. Attention is drawn to the limitation on height of cargo contained in the Load Lines Conventions where these apply.

2.10.4 A scantling correction factor, K , is to be determined from $K = \frac{h}{1,08C}$, and the hull scantlings are to be increased as follows:

- Deck longitudinals.** The section modulus is to be multiplied by the factor $0,5(1 + K)$.
- Deck beams.** The load head contained in the expression for section modulus is to be multiplied by K , and the section modulus determined using the increased value.
- Deck girders and transverses.** The section modulus is to be multiplied by the factor K .
- Pillars and deck supporting structure.** The design load is to be multiplied by the factor K , and scantlings determined using the increased value.
- Side structure.** The arrangement and scantlings of side structure are to be considered, and increased scantlings of framing may be required.

2.11 Scantlings of hatch covers

2.11.1 The scantlings of primary supporting members and secondary stiffeners are to comply with *Pt 3, Ch 11, 2.3 Load model 2.3.4* for distributed cargo load p_L using $p_C = h/C$.

2.11.2 The hatch cover securing and support arrangements, stoppers, etc. and coamings are to be suitably reinforced to take account of increased loading from timber deck cargoes, see *Pt 3, Ch 11, 4.2 Steel covers – Clamped and gasketed*.

2.12 Direct calculations

2.12.1 As an alternative to the above, the scantlings of the deck and side structure, and of hatch covers, may be assessed using direct calculations based on the proposed loading of the ship.

2.12.2 In the case of hatch covers, the stress and deflection criteria given in *Pt 3, Ch 11, 2.4 Allowable stress and deflection* corresponding to a uniformly distributed weather load are not to be exceeded.

■ *Section 3*
Decks loaded by wheeled vehicles

3.1 General

3.1.1 Where it is proposed either to stow wheeled vehicles on the deck or to use wheeled vehicles for cargo handling, the deck and supporting structure are to be designed on the basis of the maximum loading to which they may be subjected in service. Where applicable, the hatch covers are to be similarly designed. In no case, however, are the scantlings to be less than would be required as a weather or cargo deck or hatch cover, as applicable.

3.1.2 The vehicles, types and axle loads, for which the vehicle carrying decks including, where applicable, hatch covers have been approved, are to be stated in the Loading Manual and be contained in a notice displayed on each deck.

3.2 Symbols

3.2.1 The symbols used in this Section are defined in *Pt 3, Ch 9, 1.2 Symbols* and in the appropriate sub-Section.

3.3 Loading

3.3.1 Details of the deck loading resulting from the proposed stowage or operation of vehicles are to be supplied by the Shipbuilder. These details are to include the wheel load, axle and wheel spacing, tyre print dimensions and type of tyre for the vehicles.

3.3.2 For design purposes, where wheeled vehicles are to be used for cargo handling, the deck is to be taken as loaded with a normal head cargo, except in way of the vehicle.

3.4 Deck plating

3.4.1 The deck plate thickness, t , is to be not less than:

$$t = t_1 + t_c \text{ mm}$$

where

t_c = wear and wastage allowance determined from *Table 9.3.2 Wear and wastage allowance*

$$= t_1 = \frac{\alpha s}{1000\sqrt{k}} \text{ mm}$$

P_1 = corrected patch load obtained from *Table 9.3.1 Deck plate thickness calculation*

α = thickness coefficient obtained from *Figure 9.3.1 Tyre print chart*

β = tyre print coefficient used in *Figure 9.3.1 Tyre print chart*

$$= \log_{10} \left(\frac{P_1 k^2}{s^2} \times 10^7 \right)$$

Table 9.3.1 Deck plate thickness calculation

Symbols	Expression	
<i>a</i> , <i>s</i> , <i>u</i> , and <i>v</i> as defined in <i>Figure 9.3.1 Tyre print chart</i>	$P_1 = \varphi_1 \varphi_2 \varphi_3 \lambda P_w$	
<i>n</i> = tyre connection factor, see <i>Table 9.3.3 Tyre correction factor</i> , <i>n</i>	$\varphi_1 = \frac{2v_1 + 1,1s}{u_1 + 1,1s}$	<i>v</i> ₁ = <i>v</i> , but ≤ <i>s</i> <i>u</i> ₁ = <i>u</i> , but ≤ <i>a</i>
<i>P_w</i> = load, in tonnes, on the tyre print. For closely spaced wheels the shaded area shown in <i>Figure 9.3.1 Tyre print chart</i> may be taken as the combined print <i>P₁</i> = corrected patch load, in tonnes	$\varphi_2 = 1,0$ $= \frac{1}{1,3 - \frac{0,3}{s}(a - u)}$ $= 0,77 \frac{a}{u}$	for <i>u</i> ≤ (<i>a</i> - <i>s</i>) for <i>a</i> ≥ <i>u</i> > (<i>a</i> - <i>s</i>) for <i>u</i> > <i>a</i>
<i>λ</i> = dynamic magnification factor <i>φ₁</i> = patch aspect ratio correction factor	$\varphi_3 = 1,0$ $= 0,6 \frac{s}{v} + 0,4$ $= 1,2 \frac{s}{v}$	for <i>v</i> < <i>s</i> for $1,5 > \frac{v}{s} \geq 1,0$ for $\frac{v}{s} \geq 1,5$
<i>φ₂</i> = panel aspect ratio correction factor <i>φ₃</i> = wide patch load factor	<i>λ</i> = 1,25 for harbour conditions = (1 + 0,7 <i>n</i>) for sea-going conditions	

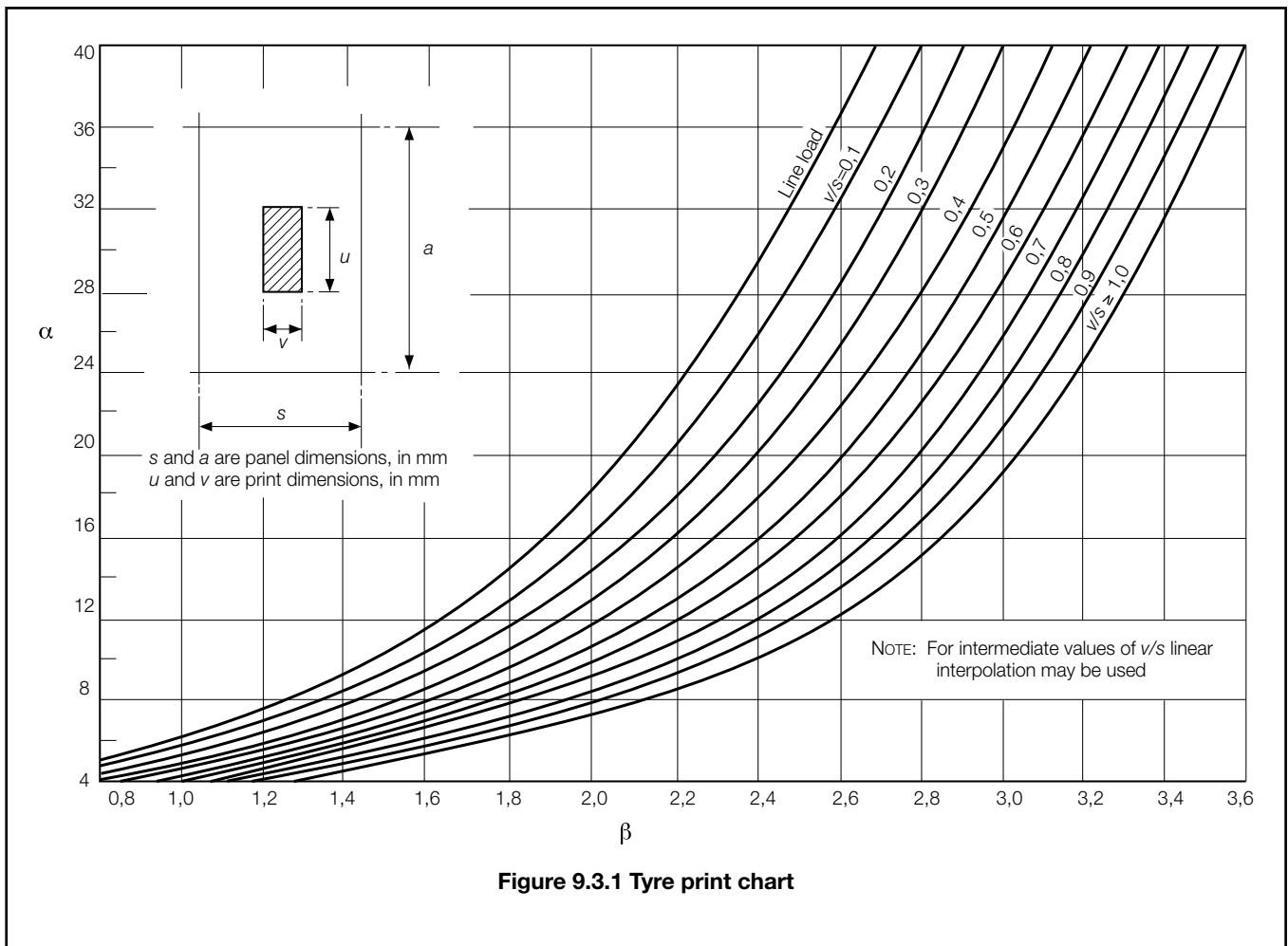

3.4.2 Where transversely framed decks contribute to the hull girder strength, or where secondary stiffening is fitted perpendicular to the direction of vehicle lanes, the thickness, *t*, derived from Pt 3, Ch 9, 3.4 Deck plating 3.4.1 is to be increased by 1,0 mm.

3.4.3 Where decks are designed for the exclusive carriage of unladen wheeled vehicles, the deck plate thickness, *t*, may be reduced as follows:

$$t = (t_1 - 0,75) + t_c \text{ mm.}$$

3.4.4 Where it is proposed to carry tracked vehicles, the patch dimensions may be taken as the track print dimensions and *P_w* is to be taken as half the total weight of the vehicle. The wear and wastage allowance from Table 9.3.2 Wear and wastage allowance is to be increased by 0,5 mm. Deck fittings in way of vehicle lanes are to be recessed.

Table 9.3.2 Wear and wastage allowance

Location	<i>t_c</i> , in mm
Strength deck, weather decks, decks forming crown of tank, inner bottom	1,5
Internal decks elsewhere	0,75

3.4.5 If wheeled vehicles are to be used on insulated decks or tank tops, consideration will be given to the permissible loading in association with the insulation arrangements and the plating thickness.

Table 9.3.3 Tyre correction factor, n

Number of wheels in idealised patch	Pneumatic tyres	Solid rubber tyres	Steel or solid tyres
1	0,6	0,8	1,0
2 or more	0,75	0,9	1,0

3.5 Deck longitudinals and beams

3.5.1 The section modulus, Z , of deck beams or longitudinals is to be not less than that required for a weather or cargo deck as appropriate, nor less than the following:

- (a) For general purpose cargo decks where fork lift trucks are to be used:

$$Z = (0,375K_1 P l_e + 0,00125 K_2 h s l_e^2) k \text{ cm}^3.$$

- (b) For permanent vehicle decks in association with a value of h which need not exceed 2,5 m:

h = normal load height on the deck, in metres

P = total weight, in tonnes, of the vehicle divided by the number of axles. Where distribution of weight is not uniform, P is to be taken as the maximum axle load. For fork lift trucks the total weight is to be applied to one axle

$$Z = (0,536K_1 P l_e + 0,00125 K_2 h s l_e^2) k \text{ cm}^3$$

= where the values of K_1 and K_2 are given in Table 9.3.4 Values of K_1 and K_2 .

- (c) For decks designed for the carriage of wheeled vehicles only that required to satisfy the most severe arrangement of print wheel loads on the stiffener in association with a bending stress of $\frac{100}{k} N/mm^2 \left(\frac{10,2}{k} kgf/mm^2 \right)$ assuming 100 per cent end fixity.

Table 9.3.4 Values of K_1 and K_2

$\frac{\text{Wheel spacing}^*}{\text{Beam span}}$	K_1	K_2
0,1	15,4	1,89
0,2	14,6	1,845
0,3	13,35	1,730
0,4	11,8	1,55
0,5 and greater	10,1	1,30

* Outer wheel to outer wheel on axles with multiple wheel arrangements

3.6 Deck girders and transverses

3.6.1 Where the load on deck girders and transverses is uniformly distributed, the section modulus is to be not less than:

$$Z = 4,75bh l_e^2 k \text{ cm}^3$$

where

h = is defined in Pt 3, Ch 9, 3.5 Deck longitudinals and beams 3.5.1

b = mean width of plating supported by a deck girder or transverse, in metres.

3.6.2 Where the member supports point loads, with or without the addition of uniformly distributed load, the section modulus is to be based on a stress of $\frac{123,6}{k} \text{ N/mm}^2 \left(\frac{12,6}{k} \text{ kgf/mm}^2 \right)$, assuming 100 per cent end fixity.

3.6.3 Where it is proposed to carry tracked vehicles, the total weight of the vehicle is to be taken when determining the section modulus of the transverse at the top of a ramp or at other changes of gradient.

3.7 Direct calculations

3.7.1 As an alternative to the above, permissible deck loads may be determined by direct calculation. The assumed loadings in these calculations are to include suitable allowance for weather, generally 2,16 kN/m² (0,22 tonne-f/m²), where applicable.

3.8 Hatch covers

3.8.1 Where wheeled vehicles are to be used, the hatch cover plating is to be not less in thickness than that required by Pt 3, Ch 9, 3.4 Deck plating, and the modulus of the stiffeners is to be not less than:

$$Z = (K_3 P l_e + 0,00167 K_4 h s l_e^2) k$$

= where the values of K_3 and K_4 are given in Table 9.3.5 Values of K_3 and K_4 and P and h are defined in Pt 3, Ch 9, 3.5 Deck longitudinals and beams 3.5.1.

In no case, however, are the scantlings of plating and stiffeners to be less than would be required as a weather or cargo deck hatch cover, as applicable.

Table 9.3.5 Values of K_3 and K_4

Wheel spacing* Stiffener span	K_3	K_4
0,1	11,96	2,32
0,2	10,69	1,89
0,3	9,58	1,55
0,4	8,46	1,28
0,5	7,46	1,07
0,6	6,51	0,91
0,7	5,55	0,73
0,8	4,23	0,36
0,9	2,38	0,11

* Outer wheel to outer wheel on axles with multiple wheel arrangements

3.8.2 Where unusual arrangements of hatch cover stiffening are proposed, the scantlings may be determined by direct calculations using a two-dimensional grillage idealisation, and the parameters given in Table 11.2.3 Effective breadth e_m of plating of primary supporting members in Pt 3, Ch 11 Closing Arrangements for Shell, Deck and Bulkheads.

3.9 Train decks

3.9.1 Decks for the transport of railway rolling stock on fixed rails will be specially considered.

3.10 Heavy and special loads

3.10.1 Where heavy or special loads, such as machinery transporters, are proposed to be carried, the scantlings and arrangements of the deck structure will be individually considered.

3.11 Securing arrangements

3.11.1 Details of the connections to the hull of vehicle securing arrangements are to be submitted for approval.

■ *Section 4*
Movable decks

4.1 Classification

4.1.1 Movable vehicle decks hoisted by means of a hydraulic or electrical winch, or lifted by a mechanical lift on board the ship, are to comply with *Ch 6 Ro-Ro Access Equipment* of LR's *Code for Lifting Appliances in a Marine Environment, November 2015*.

4.1.2 Movable decks other than described in *Pt 3, Ch 9, 4.1 Classification 4.1.1*, and which are subjected to general cargo loading, are to comply with the requirements of this Section.

4.2 Symbols

4.2.1 The symbols used in this Section are defined in *Pt 3, Ch 9, 1.2 Symbols* and in the appropriate sub-Section.

4.3 Arrangements and design

4.3.1 Movable decks are generally to be constructed as pontoons comprising a web structure with top decking. Other forms of construction will be individually considered.

4.3.2 These requirements assume that the pontoons are to be constructed of steel. Other materials will be considered on the basis of equivalent strength.

4.3.3 Positive means of control are to be provided to secure decks in the lowered position.

4.3.4 The decks are to be efficiently supported, and hinges, pillars, chains or other means (or a combination of these) are to be designed on the basis of the imposed loads. Where supporting chains and fittings are required, they are to have a factor of safety of at least two on the proof load.

4.3.5 Plans showing the proposed scantlings and arrangements of the system are to be submitted.

4.3.6 Where it is proposed to stow the pontoons on deck, when not in use, details of the proposals for racks, fittings, etc. are to be submitted for consideration.

4.4 Loading

4.4.1 Design loading for general cargo is to be specified on the plans, together with details of fork lift trucks where appropriate, and submitted for consideration.

4.5 Pontoon deck plating

4.5.1 Where the pontoon is constructed of steel decking with stiffening webs, the deck plate thickness, t , is to be not less than that required by *Pt 3, Ch 9, 3.4 Deck plating*.

4.5.2 The plate thickness, t , for aluminium pontoons is to be not less than:

$$t = (1,4t_1 + 0,75) \text{ mm}$$

where t_1 is the mild steel thickness as determined from *Pt 3, Ch 9, 3.4 Deck plating*.

For aluminium pontoons designed for the exclusive carriage of unladen wheeled vehicles:

$$t = 1,4t_1 \text{ mm}$$

4.5.3 Where it is proposed to use plywood decking, the arrangement and thickness will be considered. Plywood alone, is not, generally, to be used for axle loads in excess of 7,8 kN (0,8 tonne-f).

4.5.4 Attention is drawn to National fire regulations which in certain cases may ban the use of plywood and certain other materials in 'special category spaces' on passenger ships.

4.6 Pontoon webs and stiffeners

4.6.1 The section modulus of webs and stiffening of steel pontoons is to be not less than:

$$Z = (0,375K_1 P l_e + 0,00125K_2 h s l_e^2) k \text{ cm}^3$$

= for general-purpose cargo decks where fork lift trucks may be used where the values of K_1 and K_2 are given in *Table 9.4.1 Values of K_1 and K_2* , and

h = load height of cargo on the deck, where this is proposed to be carried, in metres.

P = the total fork lift truck load, in tonnes, is to be applied to one axle.

Table 9.4.1 Values of K_1 and K_2

Wheel spacing* Beam span	K_1	K_2
0,1	15,4	1,89
0,2	14,6	1,845
0,3	13,35	1,730
0,4	11,8	1,55
0,5 and greater	10,1	1,30

* Outer wheel to outer wheel on axles with multiple wheel arrangements

4.6.2 The section modulus of webs and stiffening of aluminium pontoons is to be not less than that defined in *Pt 3, Ch 9, 4.6 Pontoon webs and stiffeners 4.6.1* replacing k by k_a where k_a is defined in *Pt 3, Ch 2, 1 Materials of construction*.

4.6.3 Where plywood decking is proposed, or in other arrangements where the decking is not integral with the stiffening webs, the arrangement of the grillage of webs is to be such as to provide the required strength.

4.7 Deflection

4.7.1 Where wheeled vehicles are to be used, the supporting arrangements are to be such that the movement at the edge of one pontoon relative to the next does not exceed 50 mm during loading or unloading operations.

4.8 Direct calculations

4.8.1 As an alternative to *Pt 3, Ch 9, 4.3 Arrangements and design to Pt 3, Ch 9, 4.7 Deflection*, the structure may be designed on the basis of a direct calculation using a grillage idealisation. The method adopted and the stress levels proposed for the material of construction are to be submitted for consideration.

■ *Section 5*
Helicopter landing areas

5.1 General

5.1.1 Attention is drawn to the requirements and guidance of National and other Authorities concerning the construction of helicopter landing platforms and the operation of helicopters as they affect the ship. These include SOLAS *Regulation 18 - Helicopter facilities* and *Regulation 28 - Helicopter landing and pick-up areas* as applicable, as well as the *International Chamber of*

Shipping (ICS) Guide to Helicopter/Ship Operations and the International Aeronautical Search and Rescue Manual (IAMSAR) and CAP437 Standards for Offshore Helicopter Landing Areas.

5.1.2 Where the requirements of this Section have been adhered to for a designated helicopter landing platform or other deck area and fire-fighting appliances and other equipment necessary for the safe operation of helicopters are provided, the ship will be eligible for the special features notation **Helideck**. See also SOLAS Regulation 18 - Helicopter facilities.

5.1.3 Where the requirements of this Section have been complied with for an area on a ship designated for occasional or emergency landing of helicopters, the ship will be eligible for the special features notation **Occasional Helicopter Landing Area**, see SOLAS Regulation 18 - Helicopter facilities.

5.1.4 The structure is to be designed to accommodate the largest helicopter type which it is intended to use.

5.1.5 Plans are to be submitted showing the proposed scantlings and arrangements of the structure. The type, size, weight and footprint of helicopters to be used are also to be indicated. Details of the helicopter types to be used are to be included in the Loading Manual (see Pt 3, Ch 4, 8.2 Loading Manual)

5.1.6 Where the landing area forms part of a weather or erection deck, the scantlings are to be not less than those required for decks in the same position.

5.2 Symbols

5.2.1 The symbols in this Section are defined in Pt 3, Ch 9, 1.2 Symbols and in the appropriate sub-Section.

5.3 Arrangements

5.3.1 The landing area is to be sufficiently large to allow for the landing and manoeuvring of the helicopter, and is to be approached by a clear landing and take-off sector complying in extent with the applicable Regulations, International Standards, or to the satisfaction of the National Authority.

5.3.2 The landing area is to be free of any projections above the level of the deck. Projections in the zone surrounding the landing area are to be kept below the heights permitted by the Regulations, International Standards, or to the satisfaction of the National Authority.

5.3.3 Suitable arrangements are to be made to minimise the risk of personnel or machinery sliding off the landing area. A non-slip surface and anchoring devices are to be provided.

5.3.4 Engine uptake arrangements are to be sited such that exhaust gases cannot be drawn into helicopter engine intakes during helicopter take off or landing operations.

5.4 Landing area plating

5.4.1 The deck plate thickness, t , within the landing area is to be not less than:

$$t = t_1 + 1,5 \text{ mm}$$

where

$$t_1 = \frac{\alpha s}{1000\sqrt{k}} \text{ mm}$$

α = thickness coefficient obtained from Figure 9.3.1 Tyre print chart

β = tyre print coefficient used in Figure 9.3.1 Tyre print chart

$$= \log_{10} \left(\frac{P_1 k^2}{s^2} \times 10^7 \right)$$

The plating is to be designed for the emergency landing case taking:

$$P_1 = 2,5 \varphi_1 \varphi_2 \varphi_3 f_{\gamma} P_w \text{ tonnes}$$

in which $\varphi_1, \varphi_2, \varphi_3$ are to be determined from Table 9.3.1 Deck plate thickness calculation

$f = 1,15$ for landing decks over manned spaces, e.g. deckhouses, bridges, control rooms, etc.

= 1,0 elsewhere

P_h = the maximum all-up weight of the helicopter, in tonnes

P_w = landing load on the tyre print in tonnes;

for helicopters with a single main rotor, P_w is to be taken as P_h divided equally between the two main undercarriage wheels

for helicopters with tandem main rotors, P_w is to be taken as P_h distributed between all main undercarriage wheels in proportion to the static loads they carry

For helicopters fitted with landing gear consisting of skids, P_w is to be taken as P_h distributed in accordance with the actual load distribution given by the airframe manufacturer. If this is unknown, P_w is to be taken as $1/6P_h$ for each of the two forward contact points and $1/3P_h$ for each of the two aft contact points. The load may be assumed to act as a 300 mm x 10 mm line load at each end of each skid when applying *Figure 9.3.1 Tyre print chart*.

γ = a location factor given in *Table 9.5.1 Location factor*

For wheeled undercarriages, the tyre print dimensions specified by the manufacturer are to be used for the calculation. Where these are unknown, it may be assumed that the print area is 300 x 300 mm and this assumption is to be indicated on the submitted plan.

For skids and tyres with an asymmetric print, the print is to be considered oriented both parallel and perpendicular to the longest edge of the plate panel and the greatest corresponding value of α , taken from *Figure 9.3.1 Tyre print chart*.

Table 9.5.1 Location factor

Location	γ
On decks forming part of the hull girder	
(a) within 0,4L amidships	0,71 Values for intermediate locations are to be determined by interpolation
(b) at the F.P. or A.P.	0,6 Values for intermediate locations are to be determined by interpolation
Elsewhere	0,6

5.4.2 The plate thickness for aluminium decks is to be not less than:

$$t = 1,4t_1 + 1,5 \text{ mm}$$

where t_1 is the mild steel thickness as determined from *Pt 3, Ch 9, 5.4 Landing area plating 5.4.1*.

5.5 Deck stiffening and supporting structure

5.5.1 The helicopter deck stiffening and the supporting structure for helicopter platforms are to be designed for the load cases given in *Table 9.5.2 Design load cases for deck stiffening and supporting structure* in association with the permissible stresses given in *Table 9.5.3 Permissible stresses for deck stiffening and supporting structure*. The helicopter is to be positioned so as to produce the most severe loading condition for each structural member under consideration.

5.5.2 The minimum moment of inertia, I , of aluminium secondary structure stiffening is to be not less than:

$$I = \frac{5,25}{k_a} Z l_e \text{ cm}^4$$

where Z is the required section modulus of the aluminium stiffener and attached plating and k_a as defined in *Pt 3, Ch 9, 4.6 Pontoon webs and stiffeners 4.6.2*.

5.5.3 Where a grillage arrangement is adopted for the platform stiffening, it is recommended that direct calculation procedures be used.

5.6 Bimetallic connections

5.6.1 Where aluminium alloy platforms are connected to steel structures, details of the arrangements in way of the bimetallic connections are to be submitted.

Table 9.5.2 Design load cases for deck stiffening and supporting structure

Loadcase	Loads			
	Landing area		Supporting structure (See Note 1)	
	UDL, in kN/m ² (tonne-f/m ²)	Helicopter patch load (See Note 2)	Self weight	Horizontal load (See Note 2)
(1) Overall distributed loading	2 (0,2)	—	—	—
(2) Helicopter emergency landing	0,5 (0,05)	$2,5P_w f$	W_h	$0,5P_h$
(3) Normal usage	0,5 (0,05)	$1,5P_w$	W_h	$0,5P_h + 0,5W_h$
Symbols				
P_h and P_w as defined in Pt 3, Ch 9, 5.4 Landing area plating 5.4.1 UDL = Uniformly distributed vertical load over entire landing area W_h = structural self-weight of helicopter platform				
Note 1. For the design of the supporting structure for helicopter platforms, applicable self weight and horizontal loads are to be added to the landing area loads.				
Note 2. The helicopter is to be so positioned as to produce the most severe loading condition for each structural member under consideration.				

Table 9.5.3 Permissible stresses for deck stiffening and supporting structure

Loadcase (See Table 9.5.2 Design load cases for deck stiffening and supporting structure)	Permissible stresses, in N/mm ² (kgf/mm ²)			
	Deck secondary structure (beams, longitudinals) (See Notes 1 and 2)	Primary structure (transverses, girders, pillars, trusses)		All structure
	Bending		Combined bending and axial	Shear
(1) Overall distributed load	$\frac{147}{k}$ $\left(\frac{15}{k}\right)$	$\frac{147}{k}$ $\left(\frac{15}{k}\right)$	$0,6 \sigma_c$	
(2) Helicopter emergency landing	$\frac{245}{k}$ $\left(\frac{25}{k}\right)$	$\frac{220,5}{k}$ $\left(\frac{22,5}{k}\right)$	$0,9 \sigma_c$	$\frac{\text{Bending}}{\sqrt{3}}$
(3) Normal usage	$\frac{176}{k}$ $\left(\frac{18}{k}\right)$	$\frac{147}{k}$ $\left(\frac{15}{k}\right)$	$0,6 \sigma_c$	
Symbols				
<p>k = a material factor: = as defined in Pt 3, Ch 9, 1.2 Symbols for steel members = k_a as defined in Pt 3, Ch 9, 4.6 Pontoon webs and stiffeners 4.6.2 for aluminium alloy members</p> <p>σ_c = yield stress, 0,2% proof stress or compressive buckling stress, in N/mm² (kgf/mm²), whichever is the lesser</p>				
<p>Note 1. For strength deck longitudinals and girders, the permissible bending stresses are to be reduced as follows: Note (a) within 0,4L of amidships - by 30% Note (b) at the F.P. or A.P. - by 0% Values at intermediate locations are to be determined by interpolation between (a) and (b). Note 2. When determining bending stresses in secondary structure, for compliance with the above permissible stresses, 100% end fixity may be assumed.</p>				

■ **Section 6**
Lifting appliances and support arrangements

6.1 General

6.1.1 Masts, derrick posts, crane pedestals and similar supporting structures are classification items, and the scantlings and arrangements are to comply with LR's requirements whether or not LR is also requested to issue the Register of Ships' Cargo Gear and Lifting Appliances.

6.1.2 Where the lifting appliance is considered to be an essential feature of a classed ship, the special feature class notation **LA** will, in general, be mandatory.

6.1.3 Elsewhere, classification of lifting appliances is optional and may be assigned at the request of the Owner on compliance with the appropriate requirements.

6.1.4 Certain movable support structures and lifting appliances on special purpose vessels which are considered an essential feature of the vessel are to be included in the classification of the vessel.

6.1.5 Proposals to class lifting appliances on unclassified ships will be specially considered.

6.2 Masts, derrick posts and crane pedestals

6.2.1 The scantlings of masts and derrick posts, intended to support derrick booms, conveyor arms and similar loads, and of crane pedestals, are to comply with the requirements of LR's *Code for Lifting Appliances in a Marine Environment, November 2015* (hereinafter referred to as LAME).

6.2.2 In addition to the information and plans requested in LR's LAME the following details are to be submitted:

- (a) Details of masts, derrick posts or crane pedestals, together with details of the attachments to the hull structure.
- (b) Details of any reinforcement or additional supporting material fitted to the hull structure in way of the mast, derrick post or crane pedestal.

6.3 Support Structure for masts, derrick posts and crane pedestals

6.3.1 The requirements of *Pt 3, Ch 9, 6.3 Support Structure for masts, derrick posts and crane pedestals 6.3.2 and Pt 3, Ch 9, 6.3 Support Structure for masts, derrick posts and crane pedestals 6.3.3* are not applicable to Double Hull Oil Tankers or Bulk Carriers with a **CSR** notation, see *Pt 1, Ch 2, 2.3 Class notations (hull)*.

6.3.2 Masts, derrick posts and crane pedestals are to be efficiently supported and, in general, are to be carried through the deck and satisfactorily scarfed into a transverse hold or 'tween deck bulkhead. Alternatively, the masts, derrick posts or crane pedestals may be carried into a mast house, in which case the mast house is to be of substantial construction. Proposals for other support arrangements will be specially considered.

6.3.3 Deck plating and underdeck structure are to be reinforced under masts, derrick posts or crane pedestals and, where the deck is penetrated, the deck plating is to be suitably increased locally.

6.4 Lifting appliances

6.4.1 Ships or offshore units fitted with lifting appliances built in accordance with LR's LAME in respect of structural and machinery requirements will be eligible to be assigned Special Features class notations as listed in *Table 9.6.1 Special features class notations associated with lifting appliances*. This notation will be retained so long as the appliances are found upon examination at the prescribed surveys to be maintained in accordance with LR's requirements.

Table 9.6.1 Special features class notations associated with lifting appliances

Lifting appliance	Special features class notation	Remarks
Derricks, derrick cranes or cranes on ships	CG	Optional notation. Indicates that the ship's cargo gear is included in class.
Cranes on offshore installations	PC	Optional notation. Indicates that the installation's platform cranes are included in class.

Lifts and ramps on ships	CL PL CR	Optional notations. Indicate that the ship's cargo lifts (CL), passenger lifts (PL) or cargo ramps (CR) are included in class.
Lifting appliances forming an essential feature of the vessel, e.g. cranes on crane barges or pontoons, lifting arrangements for diving on diving support ships, etc.	LA	Mandatory notation. Indicates that the lifting appliance is included in class.

■ *Section 7*
Bottom strengthening for loading and unloading aground

7.1 Application

7.1.1 Where a ship of length, *L*, less than 90 m has the bottom structure additionally strengthened for loading and unloading aground in accordance with *Table 9.7.1 Bottom strengthening for loading and unloading aground*, it will be eligible for the special features notation 'bottom strengthened for loading and unloading aground'. Ships of length, *L*, 90 m or more intended for this service will receive individual consideration.

7.1.2 For dredgers intended to operate aground, the requirements of *Pt 4, Ch 12 Dredging and Reclamation Craft* are to be applied.

Table 9.7.1 Bottom strengthening for loading and unloading aground

Item	Requirement	
The following requirements are to be applied to the bottom structure upon which the ship is likely to be supported whilst aground		
(1) Bottom shell and keel plating	Thickness to be increased by 20% over the minimum requirements given in Part 4 for the particular type of ship with a minimum of 8 mm	
	For dry cargo ships, as required in way of double bottoms, see item (3)	
(2) Bottom longitudinals in way of single bottoms	For oil tankers, scantlings as required by <i>Table 9.5.1 Values of F1</i> in Pt 4, Ch 9 in taking $c_1 = 1,0$	
(3) Bottom longitudinals in way of double bottoms, see Note 1	For dry cargo ships, scantlings as required by <i>Table 1.6.1 (a) Shell framing (longitudinal)</i> in Pt 4, Ch 1 in taking $c_1 = 1,0$	
(4) Bilge longitudinals (where fitted)	Scantlings to be the same as bottom longitudinals	
	Transverse framing	Longitudinal framing
(5) Primary stiffening in way of single bottoms, see Notes 2 and 3	(a) Floors to be fitted at every frame with vertical stiffeners spaced, in general, not more than 1,25 m apart (b) One side girder is to be fitted on each side of the centreline in addition to the requirements of <i>Pt 4, Ch 1, 7 Single bottom structure</i> and intermediate 150 x 10 bulb plate longitudinals or equivalent fitted	(a) The arrangements and scantlings will receive individual consideration depending on the structural arrangements of the particular ship type (b) The spacing of transverse or floors is, in general, not to exceed 1,85 m

(6) Primary stiffening in way of double bottoms, see Notes 1, 2 and 3	(a) Plate floors are to be fitted at every frame and vertical stiffening arranged to give panel widths, in general, not exceeding 1,25 m One side girder is to be fitted on each side of the centreline in addition to the requirements of <i>Pt 4, Ch 1, 8 Double bottom structure</i> and intermediate 150 x 10 bulb plate longitudinals or equivalent fitted	(a) The spacing of floors is, in general, not to exceed 1,85 m (b) One side girder is to be fitted on each side of the centreline in addition to the requirements of <i>Pt 4, Ch 1, 8 Double bottom structure</i>
<p>Note 1. For oil tankers, to be specially considered.</p> <p>Note 2. The scantlings of floors, girders and transverses are to be determined from <i>Pt 4 Ship Structures (Ship Types)</i>, for the particular ship type.</p> <p>Note 3. The number and sizes of holes in floors, girders and transverses are to be kept to a minimum; see <i>Pt 4, Ch 1, 8 Double bottom structure</i> and <i>Pt 4, Ch 9, 6 Inner hull, inner bottom and longitudinal oiltight bulkheads</i>.</p>		

■ *Section 8*
Strengthening for regular discharge by heavy grabs

8.1 Application

8.1.1 For bulk carriers where cargoes are regularly discharged by heavy grabs and the thickness of the plating of the hold inner bottom, hopper and transverse bulkhead bottom stool is increased in accordance with the requirements of this Section, the ship will, at the Owner's option, be assigned the notation 'strengthened for regular discharge by heavy grabs'.

8.1.2 It should be noted that damage to the plating cannot be excluded even when complying with these requirements and can result from the mishandling of the grabs during the discharge of cargo.

8.1.3 The grab weight given in *Pt 3, Ch 9, 8.2 Inner bottom plating 8.2.1* does not preclude the use of heavier grabs. It is intended as an indication to the Builders, Owners and operators of the increased risk of local damage and the possibility of accelerated diminution of the plating thickness if grabs heavier than this are used regularly to discharge cargo.

8.1.4 The maximum unladen weight of the grab is to be recorded in the Loading Manual, see also *Pt 3, Ch 4, 8.2 Loading Manual 8.2.4*.

8.1.5 The requirements in this Section are not applicable to Double Hull Oil Tankers or Bulk Carriers with a **CSR** notation. See *Pt 1, Ch 2, 2.3 Class notations (hull)*.

8.2 Inner bottom plating

8.2.1 The thickness of the inner bottom plating in the holds is to be not less than required by the greater of the following:

(a)
$$t = \frac{\left(\log_{10}\left(1,775P\left(\frac{k}{s}\right)^2\right) + 5,7633\right)s - 344,5}{40,875\sqrt{k}} + 1,5 \text{ mm}$$

(b) t = the Rule required thickness, in mm in accordance with *Pt 4, Ch 7, 8 Double bottom structure* for the intended class notation.

where

P = specified unladen grab weight for the hold, in tonnes, and is not to be taken as less than 25 tonnes

s = spacing of inner bottom longitudinals, in mm

k = higher tensile steel factor as defined in *Pt 3, Ch 2, 1.2 Steel*.

8.3 Hopper side tank sloped bulkhead plating

8.3.1 The thickness of the sloped bulkhead plating adjacent to the inner bottom knuckle is to be as required by *Pt 3, Ch 9, 8.2 Inner bottom plating 8.2.1* but based on the actual spacing of stiffeners. The plating of increased thickness is to extend for a minimum distance corresponding to a vertical height of 1,5 m above the line of the inner bottom. Outboard of the plating of increased thickness, the thickness of the adjacent strakes is to be tapered to the Rule thickness for plating, as required by *Pt 4, Ch 1, 8.4 Inner bottom plating and stiffening 8.4.1*, at the top corner of the tank, see also *Pt 4, Ch 7, 9.2 Sloped bulkhead plating 9.2.3* where, in addition, the 'strengthened for heavy cargo notation' is desired.

8.4 Transverse bulkhead plating

8.4.1 The thickness of the bulkhead or stool plating adjacent to the inner bottom is to be as required by *Pt 3, Ch 9, 8.2 Inner bottom plating 8.2.1* but based on the actual spacing of the bulkhead or stool stiffeners. The plating of increased thickness is to extend for a minimum distance corresponding to a vertical height of 1,5 m above the line of the inner bottom.

Section

- 1 **General**
- 2 **Welding**
- 3 **Secondary member end connections**
- 4 **Construction details for primary members**
- 5 **Structural details**
- 6 **Access arrangements for oil tankers and bulk carriers**

■ *Section 1*
General

1.1 Application

1.1.1 This Chapter is applicable to all ship types and components.

1.1.2 Requirements are given in this Chapter for the following:

- (a) Welding-connection details, defined practices and sequence, consumables and equipment, procedures, workmanship and inspection.
- (b) End connection scantlings and constructional details for longitudinals, beams, frames and bulkhead stiffeners.
- (c) Primary member proportions, stiffening and construction details.

Additional requirements for primary structure of tankers and similar ships are given in *Pt 4, Ch 9, 6 Inner hull, inner bottom and longitudinal oiltight bulkheads*.

1.1.3 The requirements in this Chapter are not applicable to Double Hull Oil Tankers or Bulk Carriers with a CSR notation (see *Pt 1, Ch 2, 2.3 Class notations (hull)*) with the exception of *Pt 3, Ch 10, 2.5 Welding equipment* which are to be complied with.

1.2 Symbols

1.2.1 Symbols are defined as necessary in each Section.

1.2.2 The Notation **ESP** serves to identify the ships as being subject to an Enhanced Survey Programme as detailed in *Pt 1, Ch 3, 3 Intermediate Surveys - Hull and machinery requirements* and *Pt 1, Ch 3, 7 Special Survey - Oil tankers (including ore/oil ships and ore/bulk/oil ships) - Hull requirements*, see also *Pt 1, Ch 2, 2 Character of classification and class notations*.

■ *Section 2*
Welding

2.1 General

2.1.1 The plans to be submitted for approval are to indicate clearly details of the welded connections of main structural members, including the type and size of welds. This requirement includes welded connections to steel castings.

The information to be submitted should include the following:

- (a) Whether weld sizes given are throat thicknesses or leg lengths.
- (b) Grades and thicknesses of materials to be welded.
- (c) Location, types of joints and angles of abutting members.
- (d) Reference to welding procedures to be used.
- (e) Sequence of welding of assemblies and joining up of assemblies.

2.1.2 Unless otherwise indicated, all welding is to be in accordance with the requirements of *Ch 13 Requirements for Welded Construction* of the Rules for Materials.

2.2 Fillet welds

2.2.1 The throat thickness of fillet welds is to be determined from:

$$\text{Throat thickness} = t_p \times \text{weld factor} \times \frac{d}{s}$$

where

d = the distance between start positions of successive weld fillet, in mm

s = the length, in mm, of correctly proportioned weld fillet, clear of end craters, and is to be not less than 75 mm

t_p = plate thickness, on which weld fillet size is based, in mm

see also *Figure 10.2.1 Weld dimensions and types*

Weld factors are given in *Table 10.2.1 Weld factors*, *Table 10.2.3 Connections of primary structure* and *Table 10.2.4 Secondary member end connection welds*.

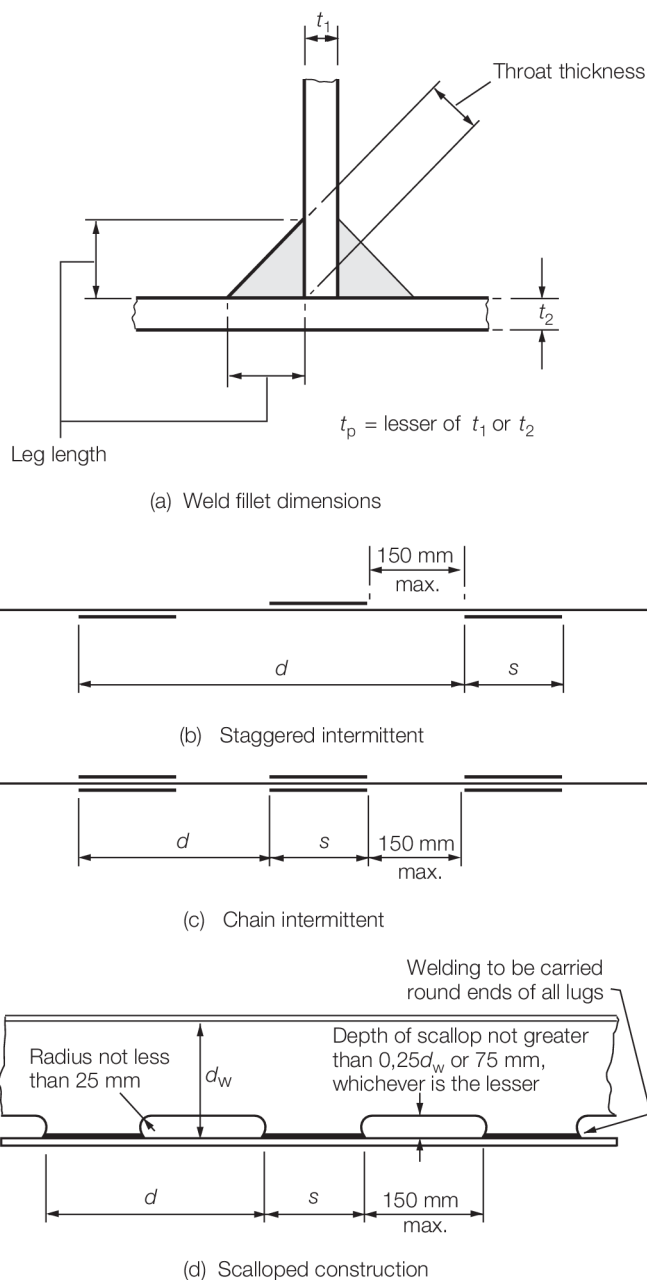

Figure 10.2.1 Weld dimensions and types

2.2.2 Where double continuous fillet welding is proposed, the throat thickness is to be determined taking $\left(\frac{d}{s}\right)$ equal to 1,0.

2.2.3 The leg length of the weld is to be not less than $\sqrt{2}$ times the specified throat thickness.

2.2.4 The plate thickness, t_p , to be used in the above calculation is generally to be that of the thinner of the two parts being joined. Where the difference in thickness is considerable, the size of fillet will be considered.

2.2.5 Where the thickness of the abutting member of the connection (e.g. the web of a stiffener) is greater than 15 mm and exceeds the thickness of the table member (e.g. plating), the welding is to be double continuous and the throat thickness of the weld is to be not less than the greatest of the following:

Welding and Structural Details

Part 3, Chapter 10

Section 2

- (a) 0,21 x thickness of the table member. The table member thickness used need not exceed 25mm.
- (b) 0,21 (0,27 in tanks) x half the thickness of the abutting member.
- (c) As required by *Table 10.2.2 Throat thickness limits*.

2.2.6 Except as permitted by *Pt 3, Ch 10, 2.2 Fillet welds 2.2.5*, the throat thickness of the weld is not to be outside the limits specified in *Table 10.2.2 Throat thickness limits*.

Table 10.2.1 Weld factors

Item	Weld factor	Remarks
(1) General application:		except as required below
Watertight plate boundaries	0,34	
Non-tight plate boundaries	0,13	
Longitudinals, frames, beams, and other secondary members to shell, deck or bulkhead plating	0,10	
	0,13	in tanks
	0,21	in way of end connections
Panel stiffeners, etc.	0,10	
Overlap welds generally	0,27	
Longitudinals of the flat-bar type to plating		see Note 5
(2) Bottom construction in way of holds or tanks:		
Non-tight centre girder: to keel	0,27	
to inner bottom	0,21	no scallops
	0,21	in way of 0,2 x span at ends
Non-tight boundaries of floors, girders and brackets	0,27	in way of brackets at lower end of main frame
Inner bottom longitudinals or reverse frames	0,13	under holds strengthened for heavy cargoes
		Weld size based on floor thickness
Connection of floors to inner bottom in way of plane bulkheads, bulkhead stools, or corrugated and double plate bulkheads supported on inner bottom. The supporting floors are to be continuously welded to the inner bottom	0,44	Weld material compatible with floor material see Note 4
(3) Hull framing;		
Webs of web frames and stringers:		
to shell	0,16	
to face plate	0,13	
Tank side brackets to shell and inner bottom	0,34	
(4) Decks and supporting structure:		
Strength deck plating to shell		as shown in <i>Table 10.2.5 Weld connection of strength deck plating to sheerstrake</i> but alternative proposals will be considered
Other decks to shell and bulkheads (except where forming tank boundaries)	0,21	generally continuous
Webs of cantilevers to deck and to shell in way of root bracket	0,44	

<p>Webs of cantilevers to face plate</p> <p>Pillars:</p> <p style="padding-left: 100px;">fabricated</p> <p style="padding-left: 100px;">end connections</p> <p style="padding-left: 100px;">end connections (tubular)</p> <p>Girder web connections and brackets in way of pillar heads and heels</p>	<p>0,21</p> <p>0,10</p> <p>0,34</p> <p>full penetration</p> <p>0,21</p>	<p>see Note 1</p> <p>continuous</p>
<p>(5) Bulkheads and tank construction, <i>see also Pt 4, Ch 7, 10 Bulkheads:</i></p> <p>Plane, double plate and corrugated watertight bulkhead boundary at bottom, bilge, inner bottom, deck and connection to shelf plate, where fitted</p> <p>Shelf plate connection to stool</p> <p>Plane, double plate and corrugated bulkhead boundaries in way of deep tanks, holds in bulk carriers (<i>see Pt 3, Ch 10, 1.1 Application 1.1.3</i>) which are floodable for the sea-going ballast condition or for the carriage of oil cargoes (Holds in bulk carriers (<i>see Pt 3, Ch 10, 1.1 Application 1.1.3</i>) which are partially flooded for harbour conditions will be specially considered):</p> <ul style="list-style-type: none"> - Boundary at bottom, bilge, inner bottom and deck - Connection of stool and bulkhead to lower stool shelf plating - Connection of stool and bulkhead plating to upper stool shelf plate - Connection of bulkhead plating to hopper and topside tanks - Connection of bulkhead plating to side shell <p>Secondary members where acting as pillars</p> <p>Non-watertight pillar bulkhead boundaries</p> <p>Perforated flats and wash bulkhead boundaries</p>	<p>0,44</p> <p>0,44</p> <p>0,44</p> <p>0,44</p> <p>0,44</p> <p>0,44</p> <p>0,44</p> <p>0,34</p> <p>0,13</p> <p>0,13</p> <p>0,10</p> <p>0,44</p> <p>full penetration</p> <p>0,44</p> <p>0,44</p> <p>0,44</p> <p>0,34</p> <p>0,13</p> <p>0,13</p> <p>0,10</p>	<p>weld size to be based on thickness of bulkhead plating</p> <p>weld material to be compatible with bulkhead plating material</p> <p>weld size to be based on thickness of stool at junction with shelf plate. Weld material to be compatible with stool material</p>
<p>(6) Structure in cargo oil tanks of tankers (<i>see Pt 3, Ch 10, 1.1 Application 1.1.3</i>):</p> <p>Bottom longitudinals to shell</p> <p>Longitudinal of flat-bar type to plating</p> <p>Connections between primary structural members</p> <p>Oiltight bulkhead boundaries:</p> <p style="padding-left: 100px;">longitudinal bulkhead</p> <p style="padding-left: 100px;">transverse bulkhead</p>	<p>0,21</p> <p>0,44</p> <p>0,34</p> <p>0,44</p> <p>0,44</p> <p>0,44</p> <p>0,34</p>	<p>for forward of 0,3L</p> <p><i>see Pt 3, Ch 10, 2.2 Fillet welds 2.2.5</i></p> <p>at bottom</p> <p>at deck</p> <p>see Note 2</p> <p>at bottom, see Note 3</p> <p>at deck, sides and longitudinal bulkhead</p>

	Vertical corrugations to an inner bottom	full penetration	
	Non-tight bulkhead boundaries to plating	0,21	
(7)	Structure in cargo tanks of chemical tankers: Tank boundary bulkheads: Type 1 ship Type 2 ship longitudinal bulkheads transverse bulkhead Type 3 ship longitudinal bulkheads transverse bulkheads transverse bulkheads at deck, sides and longitudinal bulkhead	full penetration 0,44 0,44 0,44 0,44 0,34	see Note 2 see Note 2 at bottom see Note 3
(8)	Structure in hoppers of hopper dredgers, etc.: Bulkhead boundary connections Cross members to bulkheads and keels Pillar end connections Hopper door hinges	0,44 0,34 0,44 0,34 full penetration	at bottom and bilge at deck and coamings generally
(9)	Structure in machinery space: Centre girder to keel and inner bottom Floors to centre girder in way of engine, thrust and boiler bearers Floors and girders to shell and inner bottom Main engine foundation girders: to top plate to hull structure Floors to main engine foundation girders Brackets, etc. to main engine foundation girders	0,27 0,27 0,21 deep penetration to depend on design 0,27 0,21	edge to be prepared with maximum root $0,33t_p$ deep penetration generally
(10)	Transverse and longitudinal framing to shell Construction in $0,25L$ forward: Floors and girders to shell and inner bottom Bottom longitudinals to shell Transverse and longitudinal side framing to shell Tank side brackets to frame and inner bottom	0,13 0,21 0,13 0,13 0,34	

Welding and Structural Details

Part 3, Chapter 10

Section 2

	Panting stringers to shell and frames	0,34	
	Fore peak construction:		
	all internal structure	0,13	unless a greater weld factor is required
(11)	After peak construction:		
	All internal structure and stiffeners on after peak bulkhead	0,21	unless a greater weld factor is required
(12)	Superstructure and deckhouses:		
	Connection of external bulkheads to deck	0,34	1 st and 2 nd tier erections elsewhere
		0,21	
	Internal bulkheads	0,13	
(13)	Hatchways and closing arrangements:		
	Hatchways coamings to deck	0,34	0,44 at corners
	Hatch cover rest bar	0,16	
	Hatch coaming stays to coaming	0,13	
	Hatch coamings stays to deck	0,21	
	Cleats and fittings	0,44	full penetration welding may be required
	Primary and secondary stiffening of hatch covers	0,10	0,13 for tank covers and where covers strengthened for loads over
(14)	Steering control systems:		
	Rudder:		
	Fabricated mainpiece and mainplace to side plates and webs	0,44	
	Slot welds inside plates	0,44	
	Remaining construction	0,21	
	Fixed and steering nozzles:		
	Main structure	0,44	
	Elsewhere	0,21	
	Fabricated housing and structure of thruster units, stabilisers, etc.:		
	Main structure	0,44	
	Elsewhere	0,21	
(15)	Miscellaneous fittings and equipment:		
	Rings for manhole type covers, to deck or bulkhead	0,34	
	Frames of shell and weathertight bulkhead doors	0,34	
	Stiffening of doors	0,21	
	Ventilator, air pipe, etc. coamings to deck	0,34	Load Line Positions 1 and 2 elsewhere
		0,21	
	Ventilator, etc. fittings	0,21	
	Scuppers and discharges, to deck	0,44	
	Masts, derrick posts, crane pedestals, etc. to deck	0,44	full penetration welding may be required

Deck machinery seats to deck	0,21	generally
Mooring equipment seats	0,21	generally, but increased or full penetration welding may be required
Bulwark stays to deck	0,21	
Bulwark attachment to deck	0,34	
Guard rails, stanchions, etc. to deck	0,34	
Bilge keel ground bars to shell	0,34	Continuous fillet weld, minimum throat thickness 4 mm
Bilge keels to ground bars	0,21	Light continuous fillet weld, minimum throat thickness 3 mm
Fabricated anchors	full penetration	

Note 1. Where pillars are fitted inside tanks or under watertight flats, the end connection is to be such that the tensile stress in the weld does not exceed 108 N/mm² (11 kgf/mm²).

Note 2. t_p need not be taken greater than the thickness determined from item 1(a) or 1(b) and Notes, as appropriate, of *Table 9.6.1 Inner hull and longitudinal oiltight bulkhead scantlings in Pt 4, Ch 9 Double Hull Oil Tankers*, but in no case is the weld throat thickness to be less than 0,34 x actual plate thickness.

Note 3. t_p need not be taken greater than the Rule thickness determined from *Table 9.7.1 Transverse oiltight bulkhead scantlings of Pt 4, Ch 9 Double Hull Oil Tankers* for stiffener spacing of 760 mm, but in no case is the weld throat thickness to be less than 0,34 x actual plate thickness.

Note 4. In way of bulkhead stools in ballast holds of bulk carriers or in tanks at longitudinal girder/transverse floor intersection, cut-outs are to be omitted and full penetration welding is to be applied to both floor and girder for a distance of 150 mm on either side of intersection.

Note 5. The throat thickness of the weld is to be determined by *Pt 3, Ch 10, 2.2 Fillet welds 2.2.5*. For longitudinals within $D/4$ of the strength deck and with a thickness less than 100 mm, the throat thickness need not exceed 5,5 mm.

2.2.7 Double continuous fillet welding is to be adopted in the following locations, and may be used elsewhere if desired:

- (a) Boundaries of weathertight decks and erections, including hatch coamings, companionways and other openings.
- (b) Boundaries of tanks and watertight compartments.
- (c) All structure in the after peak and the after peak bulkhead stiffeners.
- (d) All welding inside tanks intended for chemicals or edible liquid cargoes.
- (e) All lap welds in tanks.
- (f) Primary and secondary members to bottom shell in the 0,3L forward.
- (g) Primary and secondary members to plating in way of end connections, and end brackets to plating in the case of lap connections.
- (h) Where *Pt 3, Ch 10, 2.2 Fillet welds 2.2.5* applies.
- (i) All water ballast tanks.
- (j) Other connections or attachments, where considered necessary, and in particular the attachment of minor fittings to higher tensile steel plating.

2.2.8 Where intermittent welding is used, the welding is to be made double continuous in way of brackets, lugs and scallops and at the orthogonal connections with other members.

2.2.9 As an alternative to intermittent welding, single sided welding may be used. Only mechanised single sided welding is acceptable although manual single sided welding may be used at non-critical locations e.g. deck house stiffeners. Where single sided welding is used, the welding is to be made double continuous in way of brackets, lugs and scallops and at the orthogonal connections with other members.

2.2.10 Where structural members pass through the boundary of a tank, and leakage into the adjacent space could be hazardous or undesirable, full penetration welding is to be adopted for the members for at least 150 mm on each side of the

boundary. Alternatively a small scallop of suitable shape may be cut in the member close to the boundary outside the compartment, and carefully welded all round.

2.3 Welding of primary structure

2.3.1 Weld factors for the connections of primary structure are given in *Table 10.2.3 Connections of primary structure*.

Table 10.2.2 Throat thickness limits

Item	Throat thickness, in mm	
	Minimum	Maximum
(1) Double continuous welding	$0,21t_p$	$0,44t_p$
(2) Intermittent welding	$0,27t_p$	$0,44t_p$ or 4,5
(3) All welds, overriding minimum:		
(a) Plate thickness $t_p \leq 7,5$ mm		
Hand or automatic welding	3,0	—
Automatic deep penetration welding	3,0	—
(b) Plate thickness $t_p > 7,5$ mm		
Hand or automatic welding	3,25	—
Automatic deep penetration welding	3,0	—

Note 1. In all cases, the limiting value is to be taken as the greatest of the applicable values given above.

Note 2. Where t_p exceeds 25 mm, the limiting values may be calculated using a notional thickness equal to $0,4(t_p + 25)$ mm.

Note 3. The maximum throat thicknesses shown are intended only as a design limit for the approval of fillet welded joints. Any welding in excess of these limits is to be to the Surveyor's satisfaction.

2.3.2 The weld connection to shell, deck or bulkhead is to take account of the material lost in the notch where longitudinals or stiffeners pass through the member. Where the width of notch exceeds 15 per cent of the stiffener spacing, the weld factor is to be multiplied by:

$$\frac{0,85 \times \text{stiffener spacing}}{\text{length of web plating between notches}}$$

2.3.3 Where direct calculation procedures have been adopted, the weld factors for the 0,2 x overall length at the ends of the members will be considered in relation to the calculated loads.

2.3.4 The throat thickness limits given in *Table 10.2.2 Throat thickness limits* are to be complied with.

2.4 Welding of primary and secondary member end connections

2.4.1 Welding of end connections of primary members is to be such that the area of welding is not less than the cross-sectional area of the member, and the weld factor is to be not less than 0,34 in tanks or 0,27 elsewhere.

2.4.2 The welding of secondary member end connections is to be not less than as required by *Table 10.2.4 Secondary member end connection welds*. Where two requirements are given the greater is to be complied with.

2.4.3 The area of weld, A_w , is to be applied to each arm of the bracket or lapped connection.

Table 10.2.3 Connections of primary structure

Primary member face area, in cm ²		Position ⁽¹⁾	Weld factor			
Exceeding	Not exceeding		In tanks		In dry spaces	
			To face plate	To plating	To face plate	To plating
	30,0	At ends	0,21	0,27	0,21	0,21
		Remainder	0,10	0,16	0,10	0,13
30,0	65,0	At ends	0,21	0,34	0,21	0,21
		Remainder	0,13	0,27	0,13	0,16
65,0	95,0	At ends	0,34	0,44 ⁽³⁾	0,21	0,27
		Remainder	0,27 ⁽²⁾	0,34	0,16	0,21
95,0	130,0	At ends	0,34	0,44 ⁽³⁾	0,27	0,34
		Remainder	0,27 ⁽²⁾	0,34	0,21	0,27
130,0		At ends	0,44	0,44 ⁽³⁾	0,34	0,44 ⁽³⁾
		Remainder	0,34	0,34	0,27	0,34

Note 1. The weld factors 'at ends' are to be applied for 0,2 x the overall length of the member from each end, but at least beyond the toes of the member end brackets. On vertical webs the increased welding may be omitted at the top, but is to extend at least 0,3 x overall length from the bottom.

Note 2. Weld factor 0,34 in cargo oil tanks.

Note 3. Where the web plate thickness is increased locally, the weld size may be based on the thickness clear of the increase, but is to be not less than 0,34 x the increased thickness.

Note 4. In tankers over 122 m in length, the weld factor of the connection of bottom transverses to shell, and of side transverses to shell and vertical webs to longitudinal and transverse bulkheads all in the lower half depth, is to be not less than 0,34.

Note 5. The final throat thickness of the weld fillet to be not less than 0,34t_p in cargo oil tanks.

Table 10.2.4 Secondary member end connection welds

Connection	Weld area, A _w , in cm ²	Weld factor
(1) Stiffener welded direct to plating	0,25A _s or 6,5 cm ² whichever is the greater	0,34
(2) Bracketless connection of stiffeners or stiffener lapped to bracket or bracket lapped to stiffener:		
(a) in dry space	1,2√Z	0,27
(b) in tank	1,4√Z	0,34
(c) main frame to tank side bracket in 0,15L forward	as (a) or (b)	0,34
(3) Bracket welded to face of stiffener and bracket connection to plating	—	0,34
(4) Stiffener to plating for 0,1 x span at ends, or in way of end bracket if that be greater	—	0,34
Symbols		

A_s = cross sectional area of the stiffener, in cm^2

A_w = the area of the weld, in cm^2 , and is calculated as total length of weld, in cm, x throat thickness, in cm

Z = the section modulus, in cm^2 , of the stiffener on which the scantlings of the bracket are based, see Pt 3, Ch 10, 3
Secondary member end connections

Note For maximum and minimum weld fillet sizes, see Table 10.2.2 Throat thickness limits

Table 10.2.5 Weld connection of strength deck plating to sheerstrake

Item	Stringer plate thickness, mm	Weld type
1	$t \leq 15$	Double continuous fillet weld with a weld factor of 0,44
2	$15 < t \leq 20$	Single vee preparation to provide included angle of 50° with root $R \leq \frac{1}{3} t$ in conjunction with a continuous fillet weld having a weld factor of 0,39; or Double vee preparation to provide included angles of 50° with root $R \leq \frac{1}{3} t$
3	$t > 20$	Double vee preparation to provided included angles of 50° with root $R \leq \frac{1}{3} t$ but not to exceed 10 mm

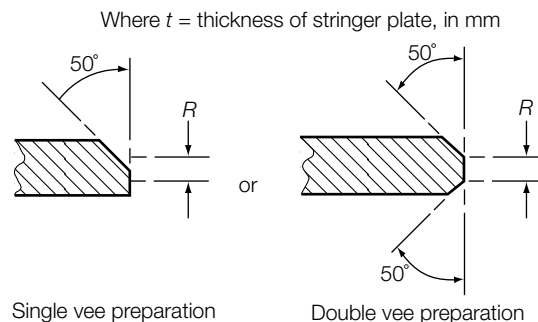

Note 1. Welding procedure, including joint preparation, is to be specified. Procedure is to be qualified and approved for individual Builders.

Note 2. See also Pt 3, Ch 10, 2.2 Fillet welds 2.2.10:

Note 3. For thickness t in excess of 20 mm the stringer plate may be bevelled to achieve a reduced thickness at the weld connection. The length of the bevel is in general to be based on a taper not exceeding 1 in 3 and the reduced thickness is in general to be not less than 0,65 times the thickness of stringer plate or 20 mm, whichever is the greater.

Note 4. Alternative connections will be considered.

2.4.4 Where a longitudinal strength member is cut at a primary support and the continuity of strength is provided by brackets, the area of weld is to be not less than the cross-sectional area of the member.

2.4.5 Where the secondary member passes through, and is supported by, the web of a primary member, the weld connection is to be in accordance with the following:

(a) In strengthening of bottom forward region:

Comply with the requirements of Pt 3, Ch 5, 1.5 Strengthening of bottom forward.

(b) Elsewhere:

Comply with the requirements of Pt 3, Ch 10, 5.2 Arrangements at intersections of continuous secondary and primary members.

2.4.6 The throat thickness limits given in Table 10.2.2 Throat thickness limits are to be complied with.

2.5 Welding equipment

2.5.1 Welding plant and equipment are to be in accordance with the requirements specified in *Ch 13, 1.8 Welding equipment and welding consumables* of the Rules for Materials.

2.6 Welding consumables and equipment

2.6.1 Welding consumables used and associated equipment is to be in accordance with the requirements specified in *Ch 13, 1.8 Welding equipment and welding consumables* of the Rules for Materials.

2.7 Welding procedures and welder qualifications

2.7.1 Welding procedures are to be established for the welding of all joints in accordance with the requirements specified in *Ch 13, 1.9 Welding procedure and welder qualifications* of the Rules for Materials.

2.7.2 All welding procedures are to be tested and qualified in accordance with the requirements of *Ch 12 Welding Qualifications* of the Rules for Materials and are to be approved by the Surveyor prior to construction.

2.7.3 Welders and welding operators are to be proficient in the type of work to be undertaken and are to be qualified in accordance with the requirements specified in *Ch 12 Welding Qualifications* of the Rules for Materials.

2.8 Workmanship and shipyard practice

2.8.1 A sufficient number of skilled supervisors is to be provided to ensure an effective and systematic control at all stages of welding operations.

2.9 Inspection of welds

2.9.1 Effective arrangements are to be provided by the Shipbuilder for the inspection of finished welds to ensure that all welding has been satisfactorily completed.

2.9.2 All finished welds are to be subjected to non-destructive examination by personnel designated by the Builder in accordance with the requirements specified in *Ch 13, 2.12 Non-destructive examination of welds* of the Rules for Materials.

2.9.3 In addition to the requirements of *Pt 3, Ch 10, 2.9 Inspection of welds 2.9.2*, a number of checkpoints are to be examined by volumetric examination as detailed in *Pt 3, Ch 10, 2.9 Inspection of welds 2.9.4* to *Pt 3, Ch 10, 2.9 Inspection of welds 2.9.9*.

2.9.4 Typical locations and number of checkpoints to be taken are shown in *Table 10.2.6 Checkpoint locations*. Critical locations as identified by *ShipRight FDA Procedure* (see *Pt 3, Ch 16 ShipRight Procedures for the Design, Construction and Lifetime Care of Ships*) are also to be considered. A plan of the proposed checkpoint locations is to be submitted for approval.

Table 10.2.6 Checkpoint locations

Item	Location	Checkpoints
Intersections of butts and seams of fabrication and section welds	Throughout: (a) hull envelope, shell envelope and deck structure plating: <ul style="list-style-type: none"> • at highly stressed areas, see Note 1 • remainder (b) longitudinal and transverse bulkheads (c) inner bottom and hopper plating:	all 1 in 2 1 in 2 1 in 2
SDA/FDA	At critical locations identified by SDA or FDA, see Note 2	all
Butt welds in plating	Throughout	1 m in 25 m, see Notes 3 and 4

Seam welds in plating	Throughout	1 m in 100 m
Butt welds in longitudinals	Hull envelope within 0,4L amidships	1 in 10 welds, see Note 5
	Hull envelope outside 0,4L amidships	1 in 20 welds
Bilge keel butt welds	Within 0,4L amidships	all
	Remainder	1 in 3
Structural items when made with full penetration welding as follows:	Throughout	
	• connection of stool and bulkhead to lower stool shelf plating	1 m in 20 m
	• vertical corrugations to an inner bottom	1 m in 20 m
	• hopper knuckles	1 m in 10 m
	• sheerstrake to deck stringer	1 m in 20 m
	• hatchways coaming to deck	1 m in 40 m
	Hatchway ends within 0,4L amidships	all
	Hatchway ends outside 0,4L amidships	1 in 2
	Remainder	1 in 40 m
<p>Note 1. Typically those at sheerstrake, deck stringer, keel strake and turn of bilge.</p> <p>Note 2. SDA signifies the <i>ShipRight Structural Design Assessment Procedure</i>, FDA signifies the <i>ShipRight Fatigue Design Assessment Procedure</i>.</p> <p>Note 3. Checkpoints in butt welds and seam welds are in addition to those at intersections.</p> <p>Note 4. Welds at inserts used to close openings in hull envelope plating are to be checked by non-destructive examination.</p> <p>Note 5. Particular attention is to be given to repair rates in butt welds in longitudinals. Additional welds are to be tested if defects such as lack of fusion or incomplete penetration are observed in more than 10 per cent of the welds examined.</p>		

2.9.5 Checkpoints are not to be identified on the ship's structural components prior to the welding taking place. Special treatment is not to be given at these locations except critical locations as identified by *ShipRight FDA Procedure*.

2.9.6 For ultrasonic examination the length of each checkpoint is to be 0,5 m and for radiographic examination the length is to be a minimum of 0,3 m. At weld intersections, examination is to be in both weld directions.

2.9.7 The Builder is to provide the Surveyor with all the NDE reports of the checkpoints. These reports are to be available for the Surveyor to review within a short time after inspection, normally considered to be within 10 working days of the examination being carried out. Where welds are repaired the NDE report is to include details of examination of both the defective weld and of the re-weld.

2.9.8 Where the Surveyor notes that a checkpoint has been repaired without record of the original defect, the shipyard is to carry out additional examinations on additional lengths of weld. These lengths are to be adjacent to and on both sides of the defective checkpoint. These additional examinations are to be carried out in the presence of the Surveyor and reported in accordance with *Pt 3, Ch 10, 2.9 Inspection of welds 2.9.7*.

2.9.9 Where checkpoints are found to contain continuous or semi-continuous defects, additional lengths of weld adjacent to and on both sides of the defective length are to be subject to further volumetric examination. The NDE reports are to be submitted in accordance with *Pt 3, Ch 10, 2.9 Inspection of welds 2.9.7*.

2.9.10 The following non-destructive examination is to be carried out on ships to be assigned the class notation '**Chemical tanker**':

(a) All crossings of butts and seams of cargo tank bulkhead plating which are welded in assembly areas or on the berth.

-
- (b) Where cargo tank boundary welding is completed in assembly areas or on the berth, a minimum of 10 per cent of the total weld length is to be crack detected.
 - (c) Where side and bottom longitudinal framing and longitudinal stiffeners terminate at transverse bulkheads, a minimum of 10 per cent of the bulkhead boundary connections is to be crack detected in addition to the requirement given in *Pt 3, Ch 10, 2.9 Inspection of welds 2.9.10*.
 - (d) Where longitudinal framing and longitudinal bulkhead stiffeners are continuous through transverse bulkheads, 30 per cent each of the bottom and shipside boundaries and 20 per cent of the longitudinal bulkhead boundaries are to be crack detected in addition to the requirement given in *Pt 3, Ch 10, 2.9 Inspection of welds 2.9.10*.
 - (e) Where transverse framing members are continuous through the cargo tank boundary, a minimum of 10 per cent of boundary connections is to be crack detected.
-

■ Section 3 Secondary member end connections

3.1 General

3.1.1 Secondary members, that is longitudinals, beams, frames and bulkhead stiffeners forming part of the hull structure, are generally to be connected at their ends in accordance with the requirements of this Section. Where it is desired to adopt bracketless connections, the proposed arrangements will be individually considered.

3.1.2 Where end connections are fitted in accordance with these requirements, they may be taken into account in determining the effective span of the member.

3.1.3 Where the section modulus of the secondary member on which the bracket is based (*see Pt 3, Ch 10, 3.3 Basis for calculation 3.3.2*) exceeds 2000 cm³, the scantlings of the connection will be considered.

3.2 Symbols

3.2.1 The symbols used in this Section are defined as follows:

a, b = the actual lengths of the two arms of the bracket, in mm, measured from the plating to the toe of the bracket

b_f = the breadth of the flange, in mm

t = the thickness of the bracket, in mm

Z = the section modulus of the secondary member, in cm³.

3.3 Basis for calculation

3.3.1 Where a longitudinal strength member is cut at a primary support and the continuity of strength is provided by brackets, the scantlings of the brackets are to be such that their section modulus and effective cross-sectional area are not less than those of the member. Care is to be taken to ensure correct alignment of the brackets on each side of the primary member.

3.3.2 In other cases the scantlings of the bracket are to be based on the modulus as follows:

(a) Bracket connecting stiffener to primary member:

modulus of the stiffener.

(b) Bracket at the head of a main transverse frame where frame terminates:

modulus of the frame.

(c) Brackets connecting lower deck beams or longitudinals to the main frame in the forward 0,15L:

modulus of the frame.

(d) Elsewhere: the lesser modulus of the members being connected by the bracket.

3.3.3 Typical arrangements of stiffener end brackets are shown diagrammatically in *Figure 10.3.1 Diagrammatic arrangements of stiffener end brackets*.

3.4 Scantlings of end brackets

3.4.1 The lengths, a and b , of the arms are to be measured from the plating to the toe of the bracket and are to be such that:

- (a) $a + b \geq 2,0 l$
- (b) $a \geq 0,8 l$
- (c) $b \geq 0,8 l$

where

$$l = 90 \left(2 \sqrt{\frac{Z}{14 + \sqrt{Z}}} - 1 \right) \text{mm}$$

but in no case is l to be taken as less than twice the web depth of the stiffener on which the bracket scantlings are to be based.

The scantlings of main frames are normally to be based on these standard brackets at top and bottom, while the scantlings of tween deck frames are normally to be based on a standard bracket at the top only. Where the actual arm lengths fitted, a_1 and b_1 (in mm) are smaller than Rule size, or bracket is omitted, an equivalent arm length, l_a , for the calculation of end connection factor, see *Table 1.6.3 Shell framing (transverse)*, is to be derived from:

(d)
$$l_a = \frac{(a_1 + b_1)}{2}$$

(e) $a_1 \geq 0,8 l_a$

(f) $b_1 \geq 0,8 l_a$

(g) $l_a = 0$, where:

- (i) bracket is omitted from the upper or lower ends of the frame, or
- (ii) lower frame bracket at bilge is at same level as the inner bottom, or
- (iii) lower frame is welded directly to the inner bottom.

3.4.2 The length of arm of tank side and hopper side brackets is to be not less than 20 per cent greater than that required above.

3.4.3 The thickness of the bracket is to be not less than as required by *Table 10.3.1 Thickness of brackets*.

3.4.4 The free edge of the bracket is to be stiffened where any of the following apply:

- (a) The section modulus, Z , exceeds 2000 cm^3 .
- (b) The length of free edge exceeds $50t$ mm.
- (c) The bracket is fitted at the lower end of main transverse side framing.

3.4.5 Where a flange is fitted, its breadth is to be not less than:

$$b_f = 40 \left(1 + \frac{Z}{1000} \right) \text{mm}$$

= but not less than 50 mm

3.4.6 Where the edge is stiffened by a welded face flat, the cross-sectional area of the face flat is to be not less than:

- (a) $0,009b_f t \text{ cm}^2$ for offset edge stiffening.
- (b) $0,014b_f t \text{ cm}^2$ for symmetrically placed stiffening.

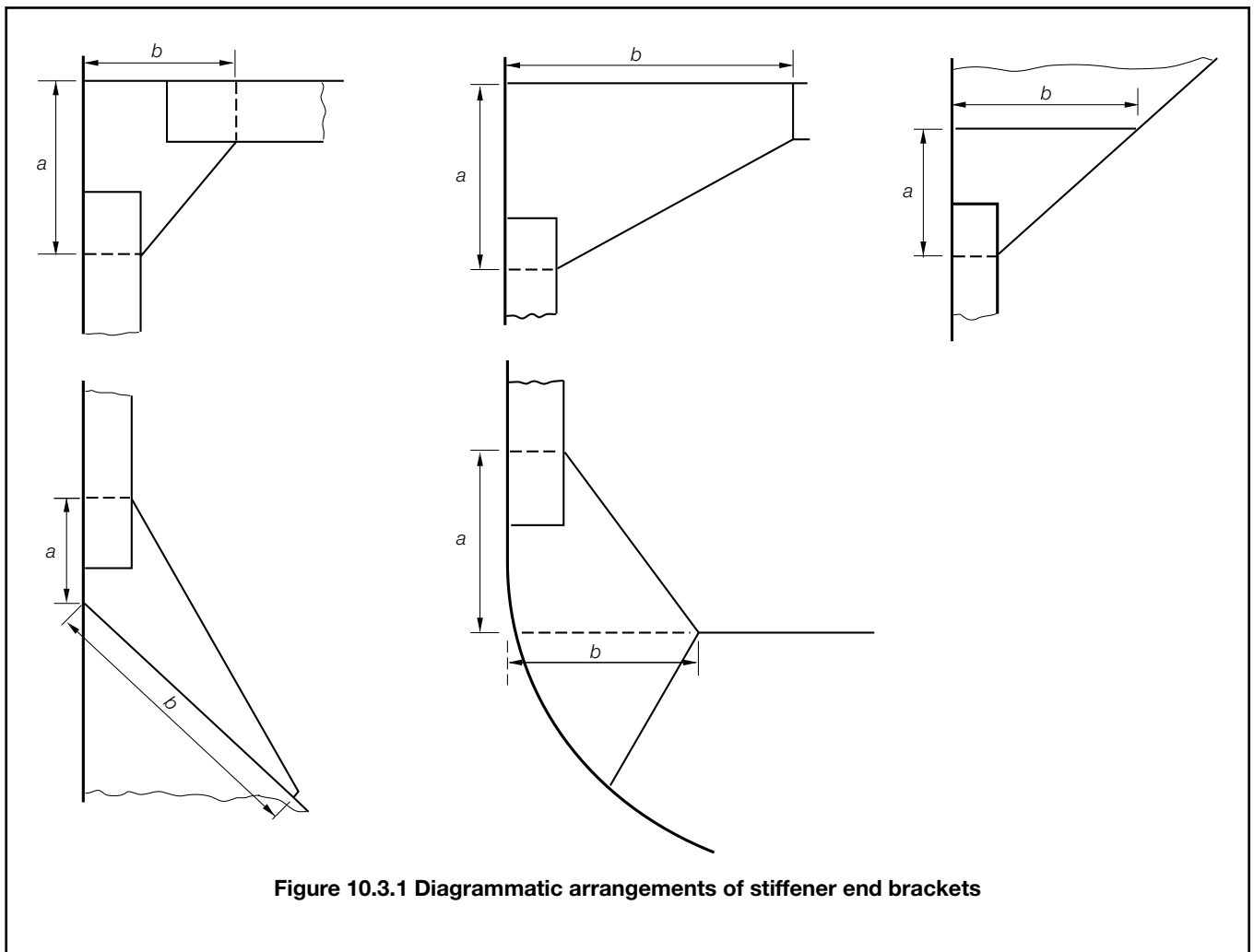

Figure 10.3.1 Diagrammatic arrangements of stiffener end brackets

Table 10.3.1 Thickness of brackets

Bracket	Thickness, in mm	Limits	
		Minimum	Maximum
With edge stiffened:			
(a) in dry spaces	$3,5 + 0,25\sqrt{Z}$	6,5	12,5
(b) in tanks	$4,5 + 0,25\sqrt{Z}$	7,5 See Note	13,5
Unstiffened brackets:			
(a) in dry spaces	$5,5 + \frac{Z}{55} - \left(\frac{Z}{168}\right)^{1,3}$	7,5	–
(b) in tanks	$6,5 + \frac{Z}{55} - \left(\frac{Z}{168}\right)^{1,3}$	8,5 See Note	–

Note In the cargo tank region of tankers, the minimum thickness is to be not less than the compartment minimum thickness, see Pt 4, Ch 9, 10 Construction details and minimum thickness.

3.4.7 Where the stiffening member is lapped on to the bracket, the length of overlap is to be adequate to provide for the required area of welding. In general, the length of overlap should be not less than $10\sqrt{Z}$ mm, or the depth of stiffener, whichever is the greater.

3.4.8 Where the free edge of the bracket is hollowed out, it is to be stiffened or increased in size to ensure that the modulus of the bracket through the throat is not less than that of the required straight edged bracket.

3.5 Arrangements and details

3.5.1 The arrangement of the connection between the stiffener and the bracket is to be such that at no point in the connection is the modulus reduced to less than that of the stiffener with associated plating.

3.5.2 The design of end connections and their supporting structure is to be such as to provide adequate resistance to rotation and displacement of the joint.

3.5.3 For arrangements where end brackets are not perpendicular to the adjacent plating the strength of the brackets, in terms of lateral stability, may need to be specially considered.

■ Section 4 **Construction details for primary members**

4.1 General

4.1.1 The requirements for section modulus and inertia (if applicable) of primary members are given in the appropriate Chapter. This Section includes the requirements for proportions, stiffening and construction details for primary members in dry spaces and in tanks of all ship types other than tankers.

4.1.2 The requirements for construction details for the primary structure of tankers are given in *Pt 4, Ch 9, 10 Construction details and minimum thickness*.

4.1.3 The requirements of this Section may be modified where direct calculation procedures are adopted to analyse the stress distribution in the primary structure.

4.2 Symbols

4.2.1 The symbols used in this Section are defined as follows:

d_w = depth of member web, in mm

k_L, k = higher tensile steel factor, see *Pt 3, Ch 2, 1.2 Steel*

t_w = thickness of member web, in mm

A_f = area of member face plate or flange, in cm²

F_D = local scantlings reduction factor as defined in *Pt 3, Ch 4, 5.6 Permissible hull vertical bending stresses*

S_w = spacing of stiffeners on member web, or depth of unstiffened web, in mm.

4.3 Arrangements

4.3.1 Primary members are to be so arranged as to ensure effective continuity of strength, and abrupt changes of depth or section are to be avoided. Where members abut on both sides of a bulkhead, or on other members, arrangements are to be made to ensure that they are in alignment. Primary members in tanks are to form a continuous line of support and wherever possible, a complete ring system.

4.3.2 The members are to have adequate lateral stability and web stiffening and the structure is to be arranged to minimise hard spots and other sources of stress concentration. Openings are to have well rounded corners and smooth edges and are to be located having regard to the stress distribution and buckling strength of the panel.

4.3.3 Primary members are to be provided with adequate end fixity by end brackets or equivalent structure. The design of end connections and their supporting structure is to be such as to provide adequate resistance to rotation and displacement of the joint and effective distribution of the load from the member.

4.3.4 Where the primary member is supported by structure which provides only a low degree of restraint against rotation, the member is generally to be extended for at least two frame spaces, or equivalent, beyond the point of support before being tapered.

4.3.5 Where primary members are subject to concentrated loads, particularly if these are out of line with the member web, additional strengthening may be required.

4.4 Geometric properties and proportions

4.4.1 The geometric properties of the members are to be calculated in association with an effective width of attached plating determined in accordance with Pt 3, Ch 3, 3.2 *Geometric properties of section*.

4.4.2 The minimum thickness or area of material in each component part of the primary member is given in *Table 10.4.1 Minimum thickness of primary members*.

4.4.3 Primary members constructed of higher tensile steel are to comply with *Table 10.4.1 Minimum thickness of primary members*.

Table 10.4.1 Minimum thickness of primary members

Item	Requirement
(1) Member web plates see Note	$t_w = 0,01S_w$ but not less than 7 mm in dry spaces and not less than 8 mm in tanks
(2) Member face plate	A_f not to exceed $\frac{d_w t_w}{150} \text{ cm}^2$
(3) Deck plating forming the upper flange of underdeck girders	Plate thickness not less than $\sqrt{\frac{A_f}{1,8k}}$ mm, and 10 per cent greater for hatch side girders Width of plate not less than 700 mm
(4) Primary members in cargo oil tanks in tankers	As required by Pt 4, Ch 9, 10 <i>Construction details and minimum thickness</i>
NOTE For primary members having a web depth exceeding 1500 mm, the arrangement of stiffeners will be individually considered, and stiffening parallel to the member face plate may be required.	

4.5 Web stability

4.5.1 Primary members of asymmetrical section are to be supported by tripping brackets at alternate secondary members. If the section is symmetrical, the tripping brackets may be four spaces apart.

4.5.2 Tripping brackets are also to be fitted at the toes of end brackets and in way of heavy or concentrated loads such as the heels of pillars.

4.5.3 Where the ratio of unsupported width of face plate (or flange) to its thickness exceeds 16:1, the tripping brackets are to be connected to the face plate and on members of symmetrical section, the brackets are to be fitted on both sides of the web.

4.5.4 Intermediate secondary members may be welded directly to the web or connected by lugs.

4.5.5 Where the depth of web of a longitudinal girder at the strength deck within 0,4L amidships exceeds:

(a) $55t_w$ for mild steel members

(b) $55t_w \sqrt{\frac{k_L}{F_D}}$ for higher tensile steel members

additional longitudinal web stiffeners are to be fitted at a spacing not exceeding the value given in (a) or (b) as appropriate, with a maximum of $65t_w \sqrt{k_L}$ for higher tensile steel members. In cases where this spacing is exceeded, the web thickness is, in general, to be suitably increased.

4.5.6 The arm length of unstiffened end brackets is not to exceed $100t_w$. Stiffeners parallel to the bracket face plate are to be fitted where necessary to ensure that this limit is not exceeded.

4.5.7 Web stiffeners may be flat bars of thickness t_w and depth $0,1d_w$, or 50 mm, whichever is the greater. Alternative sections of equivalent moment of inertia may be adopted.

4.6 Openings in the web

4.6.1 Where openings are cut in the web, the depth of opening is not to exceed 25 per cent of the web depth, and the opening is to be so located that the edges are not less than 40 per cent of the web depth from the face plate. The length of opening is not to exceed the web depth or 60 per cent of the secondary member spacing, whichever is the greater, and the ends of the openings are to be equidistant from the corners of cut-outs for secondary members. Where larger openings are proposed, the arrangements and compensation required will be considered.

4.6.2 Openings are to have smooth edges and well rounded corners.

4.6.3 Cut-outs for the passage of secondary members are to be designed to minimise the creation of stress concentrations. The breadth of cut-out is to be kept as small as practicable and the top edge is to be rounded, or the corner radii made as large as practicable. The extent of direct connection of the web plating, or the scantlings of lugs or collars, is to be sufficient for the load to be transmitted from the secondary member.

4.7 End connections

4.7.1 End connections of primary members are generally to comply with the requirements of *Pt 3, Ch 10, 3 Secondary member end connections*, taking Z as the section modulus of the primary member.

4.7.2 The thickness of the bracket is to be not less than that of the primary member web. The free edge of the bracket is to be stiffened.

4.7.3 Where a deck girder or transverse is connected to a vertical member on the shell or bulkhead, the scantlings of the latter may be required to be increased to provide adequate stiffness to resist rotation of the joint.

4.7.4 Where a member is continued over a point of support, such as a pillar or pillar bulkhead stiffener, the design of the end connection is to be such as to ensure the effective distribution of the load into the support. Proposals to fit brackets of reduced scantlings, or alternative arrangements, will be considered.

4.7.5 Connections between primary members forming a ring system are to minimise stress concentrations at the junctions. Integral brackets are generally to be radiused or well rounded at their toes. The arm length of the bracket, measured from the face of the member, is to be not less than the depth of the smaller member forming the connection.

■ Section 5 Structural details

5.1 Continuity and alignment

5.1.1 The arrangement of material is to be such as will ensure structural continuity. Abrupt changes of shape or section, sharp corners and points of stress concentration are to be avoided.

5.1.2 Where members abut on both sides of a bulkhead or similar structure, care is to be taken to ensure good alignment.

5.1.3 Pillars and pillar bulkheads are to be fitted in the same vertical line wherever possible, and elsewhere arrangements are to be made to transmit the out of line forces satisfactorily. The load at head and heel of pillars is to be effectively distributed and arrangements are to be made to ensure the adequacy and lateral stability of the supporting members.

5.1.4 Continuity is to be maintained where primary members intersect and where the members are of the same depth, a suitable gusset plate is to be fitted.

5.1.5 End connections of structural members are to provide adequate end fixity and effective distribution of the load into the supporting structure.

5.1.6 The toes of brackets, etc. should not land on unstiffened panels of plating. Special care should be taken to avoid notch effects at the toes of brackets, by making the toe concave or otherwise tapering it off.

5.1.7 Where primary and/or secondary members are constructed of higher tensile steel, particular attention is to be paid to the design of the end bracket toes in order to minimise stress concentrations. Sniped face plates which are welded onto the edge of primary member brackets are to be carried well around the radiused bracket toe and are to incorporate a taper not exceeding 1 in 3. Where sniped face plates are welded adjacent to the edge of primary member brackets, adequate cross sectional area is to be provided through the bracket toe at the end of the snipe. In general, this area measured perpendicular to the face plate, is to be not less than 60 per cent of the full cross-sectional area of the face plate, see *Figure 10.5.1 Bracket toe construction*. See also *Pt 4, Ch 1, 4.3 Deck stiffening, Pt 4, Ch 1, 6.1 General, Pt 4, Ch 9, 5.7 Connections of longitudinals and Pt 4, Ch 9, 10.13 Brackets connecting primary members*.

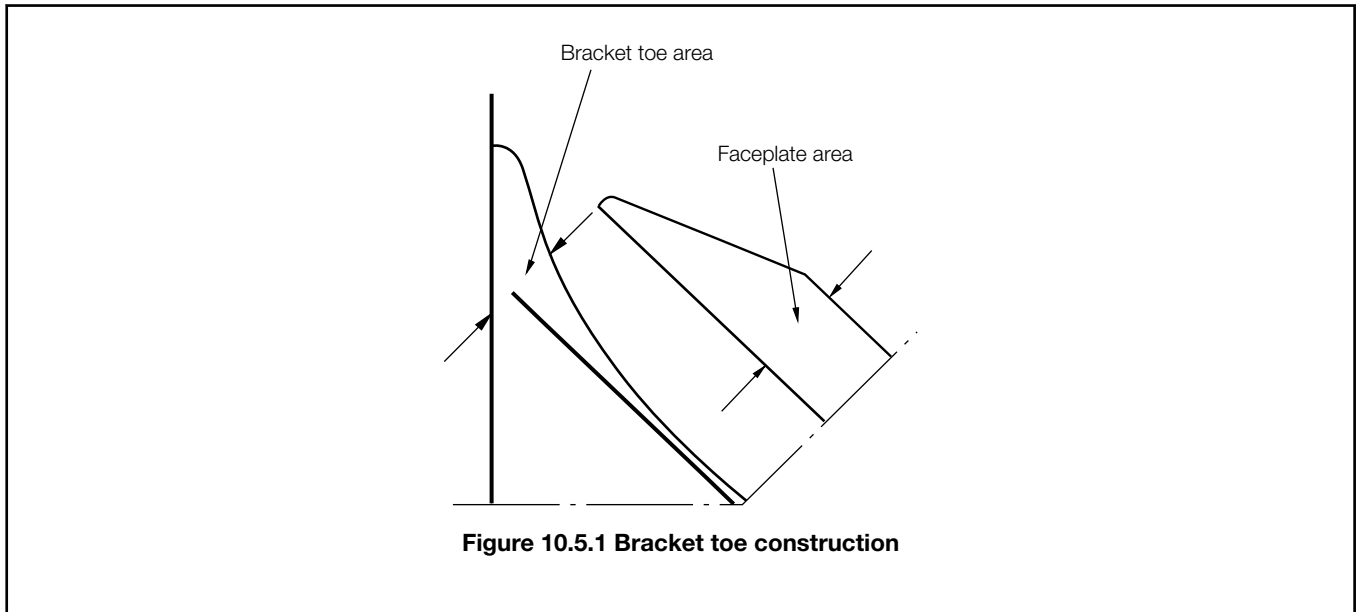

5.2 Arrangements at intersections of continuous secondary and primary members

5.2.1 Cut-outs for the passage of secondary members through the web of primary members, and the related collaring arrangements, are to be designed to minimise stress concentrations around the perimeter of the opening and in the attached hull envelope or bulkhead plating. The critical shear buckling stress of the panel in which the cut-out is made is to be investigated. Cut-outs for longitudinals will be required to have double lugs in areas of high stress, e.g. in way of cross tie ends and floors under bulkhead stools in ore and ballast holds.

5.2.2 Cut-outs are to have smooth edges, and the corner radii are to be as large as practicable, with a minimum of 20 per cent of the breadth of the cut-out or 25 mm, whichever is the greater. It is recommended that the web plate connection to the hull envelope or bulkhead should end in a smooth tapered 'soft toe'. Recommended shapes of cut-out are shown in *Figure 10.5.2 Cut-outs and connections*, but consideration will be given to other shapes on the basis of maintaining equivalent strength and minimizing stress concentration. Consideration is to be given to the provision of adequate drainage and unimpeded flow of air and water when designing the cut-outs and connection details.

5.2.3 Asymmetrical secondary members are to be connected on the heel side to the primary member web plate. Additional connection by lugs on the opposite side may be required.

5.2.4 Symmetrical secondary members are to be connected by lugs on one or both sides, as necessary.

5.2.5 The cross-sectional areas of the connections are to be determined from the proportion of load transmitted through each component in association with its appropriate permissible stress.

5.2.6 The total load *P*, transmitted to the primary member is to be derived in accordance with *Table 10.5.1 Total load transmitted to connection of secondary members*.

5.2.7 This load is to be apportioned between the connections as follows:

(a) Transmitted through the collar arrangement:

$$P_1 = P \left(\frac{s_1}{S_w} + \frac{A_1}{4C_f A_f + A_1} \right)$$

where A_f is derived in accordance with Pt 3, Ch 10, 5.2 Arrangements at intersections of continuous secondary and primary members 5.2.9 and $\frac{s_1}{S_w}$ is not to be taken as greater than 0,25

The collar load factor, C_f , is to be derived as follows:

Symmetrical secondary members

$C_f = 1,85$	for $A_f \leq 18$
$C_f = 1,85 - 0,0341 (A_f - 18)$	for $18 < A_f \leq 40$
$C_f = 1,1 - 0,01 (A_f - 40)$	for $A_f > 40$

Asymmetrical secondary members

$$C_f = 0,68 + 0,0224 \frac{b_l}{A_f}$$

where

A_f = the area, in cm^2 , of the primary member web stiffener in way of the connection including backing bracket, where fitted (see Pt 3, Ch 10, 5.2 Arrangements at intersections of continuous secondary and primary members 5.2.11)

b_l = the length of lug or direct connection, in mm, as shown in Figure 10.5.2 Cut-outs and connections. Where the lug or direct connections differ in length a mean value of b_l is to be used.

(b) Transmitted through the primary member web stiffener:

$$P_2 = P - P_1 \text{ kN(tonne - f)}$$

(c) Where the web stiffener is not connected to the secondary member, P_1 is to be taken equal to P .

Table 10.5.1 Total load transmitted to connection of secondary members

Ship type	Head, h_1 , in metres	Total load, P , transmitted to connection
(1) Oil tankers, bulk chemical tankers and combination carriers, see Pt 3, Ch 10, 1.1 Application 1.1.3	<p>h_1 = load height, in metres, derived in accordance with the following provisions, but to be taken as not less than $\frac{L_1}{56}$ or $(0,01L_1 + 0,7)$ m whichever is the greater</p> <p>For shell framing members:</p> <p>(a) With mid-point of span at base line, $h_1 = 0,8D_2$</p> <p>(b) With mid-point of span at a distance $0,6D_2$ above base line, $h_1 = f D_2 B_f$</p> <p>(c) With mid-point of span intermediate between (a) and (b). The value of h_1 is to be obtained by linear interpolation between values from (a) and (b).</p> <p>(d) With mid-point of span higher than $0,6D_2$ above base line.</p> <p>The value of h_1 is to be obtained by linear interpolation between the values from (b) and the values at the following points:</p>	<p>(a) In general</p> $P = 10,06 (S_w - s_1/2) s_1 h_1 \text{ kN}$ $(P = 1,025 (S_w - s_1/2) s_1 h_1 \text{ tonne-f)}$ <p>(b) For wash bulkheads</p> $P = 11,77 (S_w - s_1/2) s_1 h_1 \text{ kN}$

	<p>(i) For framing members located at and abaft 0,2L from the forward perpendicular (see Figure 10.5.2)</p> <p>Zero value at the level of the deck edge amidships</p> <p>(ii) For framing members forward of cargo tank region (see Fig. 10.5.2(b))</p> <p>Value of $f D_2 (B_f - 1)$ at the level 3 m above the minimum bow height determined from the Load Lines Convention</p> <p>(iii) Intermediate values between locations (i) and (ii) are to be determined by linear interpolation</p> <p>For secondary stiffening members of transverse and longitudinal bulkheads, and inner hull an inner bottom of double hull tankers, see Pt 3, Ch 10, 1.1 Application 1.1.3:</p> <p style="text-align: center;">h_1 = distance from the mid-point of span to top of tank but need not exceed $0,8D_2$</p>	<p style="text-align: right;">$(P = 1,2 (S_w - s_{1/2}) s_1 h_1 \text{ tonne-f})$</p>
<p>(2) Other ship types for which oil tanker (see Pt 3, Ch 10, 1.1 Application 1.1.3) requirements are not applicable</p>	<p>Side and bottom shell longitudinals</p> <p>As for (1) except as follows:</p> <p>(a) h_1 to be derived in accordance with (1) above but to be taken as not less than $\frac{L_1}{56}$ m for type 'B-60' and the greater of $\frac{L_1}{70}$, or 1,20 m for Type 'B' ships</p> <p>(b) h_1 for item (1)(d)(ii) above to extend forward of 0,15L from the forward perpendicular</p>	<p style="text-align: right;">$P = 10,06 (S_w - s_{1/2}) s_1 h_1 \text{ kN}$</p> <p style="text-align: right;">$(P = 1,025 (S_w - s_{1/2}) s_1 h_1 \text{ tonne-f})$</p>
<p>(3) Other ship types for which oil tanker (see Pt 3, Ch 10, 1.1 Application 1.1.3) requirements are not applicable (continued)</p>	<p>Internal tank boundaries</p> <p>(a) Topside tank longitudinals</p> <p>h_1 = distance from the longitudinal under consideration to the highest point of the tank with the ship inclined 30° either way, or</p> <p>= the greater of the distance from the longitudinal under consideration to the top of the tank, or half the distance to the top of the overflow, or</p> <p>= 1,5 m</p> <p>= whichever is the greatest</p> <p>(b) Inner bottom and hopper longitudinals</p>	<p style="text-align: right;">$P = 10,06 (S_w - s_{1/2}) s_1 h_1 \text{ kN}$</p> <p style="text-align: right;">$(P = 1,025 (S_w - s_{1/2}) s_1 h_1 \text{ tonne-f})$</p> <p style="text-align: right;">$P = 9,81 (S_w - s_{1/2}) s_1 h_1 / C \text{ kN}$</p> <p style="text-align: right;">$P = (S_w - s_{1/2}) s_1 h_1 / C \text{ tonne-f}$</p> <p>= but not to be taken less than the load derived from (b) (iv), (b)(v), (b)(vi) or (c) where applicable</p>

	<p>(i) For cargo ships and bulk carriers (see Pt 3, Ch 10, 1.1 Application 1.1.3) without the notation 'strengthened for heavy cargoes' $h_1 = 1,39T$</p> <p>(ii) For cargo ships and bulk carriers (see Pt 3, Ch 10, 1.1 Application 1.1.3) with the notation 'strengthened for heavy cargoes' $h_1 = H$</p> <p>For longitudinal bulkheads of ore carriers $h_1 = HK_c$</p> <p>(iv) For bulk carriers (see Pt 3, Ch 10, 1.1 Application 1.1.3) where the topside wing tank is interconnected with hopper side and double bottom tanks h_1 = the distance from the longitudinal under consideration to the top of the topside tank with the ship inclined 25° either way</p> <p>(v) For bulk carriers (see Pt 3, Ch 10, 1.1 Application 1.1.3) in way of ballast hold h_1 = the distance from the longitudinal under consideration to the top of the hatchway coaming</p> <p>(vi) For cargo ships and bulk carriers (see Pt 3, Ch 10, 1.1 Application 1.1.3) with double hull where tank at side interconnected with double bottom $h_1 = H$</p> <p>(c) Longitudinals of inner hull of double hull cargo ships and bulk carriers (see Pt 3, Ch 10, 1.1 Application 1.1.3) h_1 = the distance from the longitudinal under consideration to the top of the tank, or half the distance to the top of the overflow, whichever is the greater</p>		
			$P = 10,06 (S_w - s_1/2) s_1 h_1 kN$
			$(P = 1,025 (S_w - s_1/2) s_1 h_1 \text{ tonne-f})$
			$P = 10,06 (S_w - s_1/2) s_1 h_1 kN$
			$(P = 1,025 (S_w - s_1/2) s_1 h_1 \text{ tonne-f})$
			$P = 10,06 (S_w - s_1/2) s_1 h_1 kN$
			$(P = 1,025 (S_w - s_1/2) s_1 h_1 \text{ tonne-f})$
			$P = 10,06 (S_w - s_1/2) s_1 h_1 kN$
			$(P = 1,025 (S_w - s_1/2) s_1 h_1 \text{ tonne-f})$

B_f = bow fullness factor determined from Figure 5.4.3 Illustration of bow fullness factor determination in Chapter 5 to be considered. To be taken as 1 for framing members located at and abaft 0,2L from the forward perpendicular

f = load height factor at level 0,6D above base line, see Table 10.5.2 Load height factor, f

h_1 = load height, in metres, see also Figure 10.5.2

C = stowage rate, in m³ /tonne, as defined in Pt 3, Ch 3, 5.2 Symbols. For cargo ships without the notation 'strengthened for heavy cargoes', the value to be used is 1,39 m³/tonne. For cargo ships and bulk carriers (see Pt 3, Ch 10, 1.1 Application 1.1.3) with the notation 'strengthened for heavy cargoes', the actual stowage rate is to be used, but the value is not to be taken greater than 0,865 m³/tonne

H = height from inner bottom at position under consideration, to deck at side amidships, in metres, for inner bottom longitudinals

= height from the longitudinal under consideration to the underside of the topside tank sloped bulkhead, in metres, for hopper longitudinals

S_w = spacing of primary members, in metres

s_1 = spacing of secondary members, in metres

T = the summer draught, in metres, measured from top of keel

D_2 = D in metres, but need not be taken greater than $1,6T$

L_1 = L but need not be taken as greater than 190 m

K_c = as defined in Table 11.7.1 Longitudinal and transverse bulkhead scantlings for ore loading in Pt 4, Ch 11 Ore Carriers

Table 10.5.2 Load height factor, f

		Ship depth, D metres					
		$\leq 17,5$	20	22.5	25	27.5	30
(1)	(a) For oil tankers, bulk chemical tankers and combination carriers (see Pt 3, Ch 10, 1.1 Application 1.1.3), tank boundaries wholly within parallel mid-body	0,6	0,6	0,582	0,556	0,535	0,517
	(b) For other ship types, at an abaft of $0,2L$ from the forward perpendicular						
(2)	(a) For oil tankers, bulk chemical tankers and combination carriers (see Pt 3, Ch 10, 1.1 Application 1.1.3), tank boundaries wholly or partially outside parallel mid-body	0,7	0,685	0,685	0,628	0,6	0,577
	(b) For other ship types, forward of $0,15L$ from the forward perpendicular						

Note Intermediate values to be obtained by linear interpolation

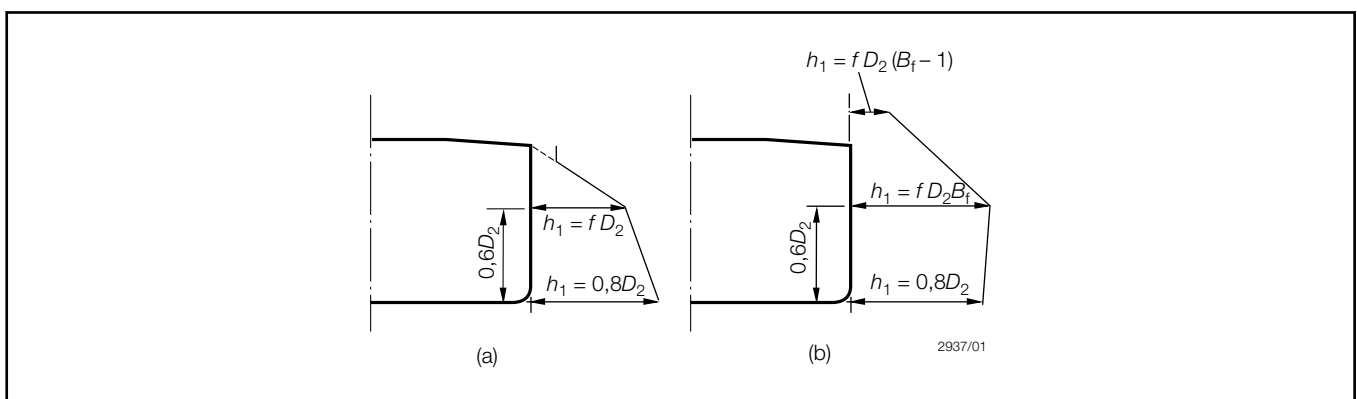

5.2.8 **Load height diagrams for framing members (a) at and abaft $0,2L$ from the forward perpendicular and (b) forward of cargo tank region for oil tankers, bulk chemical tankers and combination carriers (see Pt 3, Ch 10, 1.1 Application 1.1.3) and forward of $0,15L$ from the forward perpendicular for other ship types**

5.2.9 The effective cross-sectional area A_1 of the collar arrangements is to be taken as the sum of cross-sectional areas of the components of the connection as follows:

(a) Direct connection:

$$A_1 = 0,01b_l t_w \text{ cm}^2$$

(b) Lug connection:

$$A_1 = 0,01f_1 b_l t_l \text{ cm}^2$$

where

$f_1 = 1,0$ for symmetrical secondary member connections

$= \frac{140}{W_l}$ but not greater than 1,0, for asymmetrical secondary member connections

t_w = thickness of primary member web, in mm

t_2 = thickness, in mm, of lug connection, and is to be taken not greater than the thickness of the adjacent primary member web plate

W = overall width of the cut-out, in mm

W_2 = width for cut-out asymmetrical to secondary member web, in mm

see Figure 10.5.2 *Cut-outs and connections*

5.2.10 The values of A_f and A_1 are to be such that the stresses given in Table 10.5.3 *Permissible stresses* are not exceeded.

5.2.11 Where a bracket is fitted to the primary member web plate in addition to a connected stiffener it is to be arranged on the opposite side to, and in alignment with the stiffener. The arm length of the bracket is to be not less than the depth of the stiffener, and its cross-sectional area through the throat of the bracket is to be included in the calculation of A_f .

5.2.12 In general where the primary member stiffener is connected to the secondary member it is to be aligned with the web of the secondary member, except where the face plate of the latter is offset and abutted to the web, in which case the stiffener connection is to be lapped. Lapped connections of primary member stiffeners to mild steel bulb plate or rolled angle secondary members may also be permitted. Where such lapped connections are fitted, particular care is to be taken to ensure that the primary member stiffener wrap around weld connection is free from undercut and notches, see also Pt 3, Ch 10, 2.9 *Inspection of welds*.

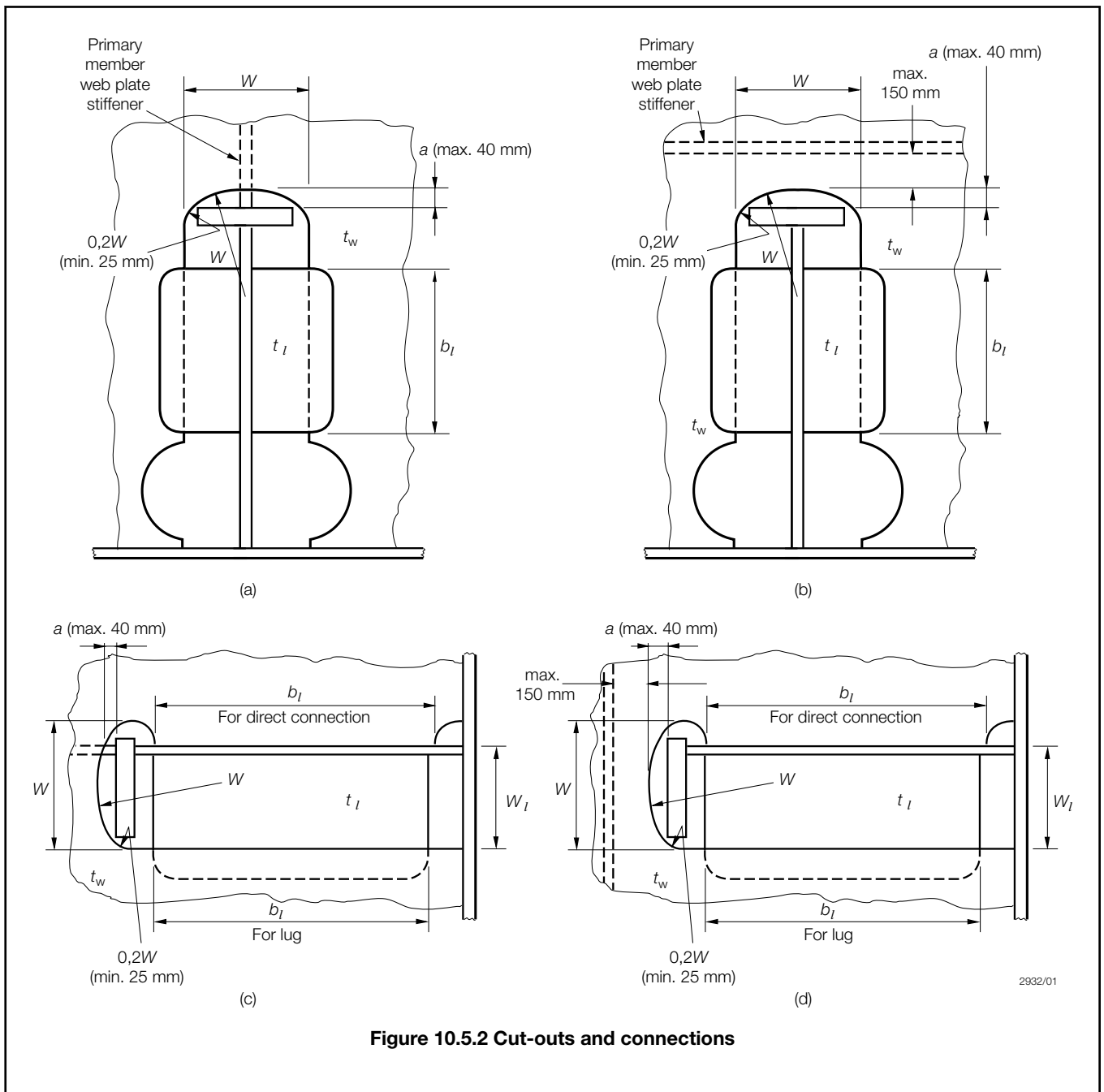

Figure 10.5.2 Cut-outs and connections

5.2.13 Fabricated longitudinals having the face plate welded to the underside of the web, leaving the edge of the web exposed, are not recommended for side shell and longitudinal bulkhead longitudinals. Where it is proposed to fit such sections, a symmetrical arrangement of connection to transverse members is to be incorporated. This can be achieved by fitting backing brackets on the opposite side of the transverse web or bulkhead. The primary member stiffener and backing brackets are to be lapped to the longitudinal web, see Pt 3, Ch 10, 5.2 Arrangements at intersections of continuous secondary and primary members 5.2.12.

5.2.14 For ship types for which oil tanker (see Pt 3, Ch 10, 1.1 Application 1.1.3) requirements are not applicable, the collar arrangement is to satisfy the requirements of Pt 3, Ch 10, 5.2 Arrangements at intersections of continuous secondary and primary members 5.2.1 to Pt 3, Ch 10, 5.2 Arrangements at intersections of continuous secondary and primary members 5.2.13 inclusive. In addition the weld area of the connections is to be not less than the following:

- (a) Connection of primary member stiffener to the secondary member:

$A_w = 0,25 A_f$ or $6,5 \text{ cm}^2$, whichever is the greater, corresponding to a weld factor of 0,34 for the throat thickness

(b) Connection of secondary member to the web of the primary member:

$A_w = 0,5\sqrt{Z}$ corresponding to a weld factor of 0,34 in tanks or 0,27 in dry spaces for the throat thickness

where

A_w = weld area, in cm^2 , and is calculated as total length of weld, in cm, multiplied by throat thickness, in cm

A_f = cross-sectional area of the primary member web stiffener, in cm^2 , in way of connection

Z = the section modulus, in cm^3 , of the secondary member.

Table 10.5.3 Permissible stresses

Item	Direct stress, in N/mm^2 (kgf/mm^2) (see Notes 1 and 2)		Shear stress, in N/mm^2 (kgf/mm^2) (see Note 1)	Other ship types for which oil tanker requirements are not applicable	
	Oil tankers	Other ship types for which oil tanker requirements are not applicable	Oil tankers and ship types where primary member stiffener unconnected		
Primary member web plate stiffener within distance a of end see <i>Figure 10.5.2 Cut-outs and connections</i>	147,2 (15,0)	157 (16,0)	—	—	
Welding of primary member web plate stiffener to secondary member	Butted	98,1 (10,0) (double continuous fillet) 147,2 (15,0) (automatic deep penetration)	117,7 (12,0) (double continuous fillet) 157 (16,0) (automatic deep penetration)	— —	— —
	Lapped	—	—	83,4 (8,5) See Note 2	98,1 (10,0) See Note 2
Lug or collar plate and weld	Single	—	—	68,6 (7,0)	98,1 (10,0)
	Double	—	—	83,4 (8,5)	
<p>Note (1) The welding requirements of <i>Pt 3, Ch 10, 2 Welding</i>, and where applicable <i>Pt 3, Ch 10, 5.2 Arrangements at intersections of continuous secondary and primary members 5.2.14</i> are also to be complied with, see <i>Pt 3, Ch 10, 1.1 Application 1.1.3</i>.</p> <p>Note (2) Where longitudinals are of higher tensile steel having a yield stress of 32 kg/mm^2 or more, these stresses are to be divided by the factor 1,2 for application to side longitudinals above $0,3D_2$ from the base-line. For definition of D_2 see <i>Table 10.5.1 Total load transmitted to connection of secondary members</i>.</p>					

5.2.15 Where the stiffeners of the double bottom floors, and the hopper primary members are unconnected to the secondary members and offset from them (see *Figure 10.5.3 Arrangement with offset stiffener*) the collar arrangement is to satisfy the requirements of *Pt 3, Ch 10, 5.2 Arrangements at intersections of continuous secondary and primary members 5.2.1* to *Pt 3, Ch 10, 5.2 Arrangements at intersections of continuous secondary and primary members 5.2.14* inclusive. In addition, the fillet welds attaching the lugs to the secondary members are to be based on a weld factor of 0,44 for the throat thickness. To facilitate access for welding the offset stiffeners are to be located 50 mm from the slot edge furthest from the web of the secondary member. The ends of the offset stiffeners are to be suitably tapered and softened.

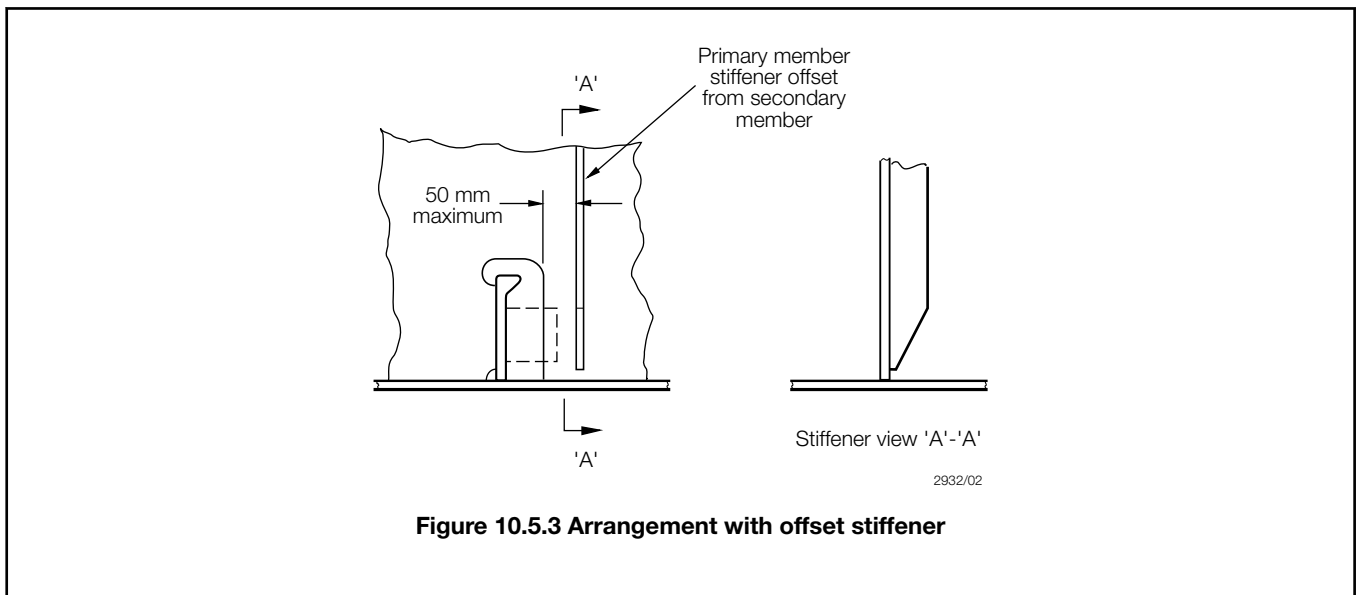

5.2.16 Alternative arrangements will be considered on the basis of their ability to transmit load with equivalent effectiveness. Details of the calculations made and testing procedures are to be submitted.

5.3 Openings

5.3.1 Manholes, lightening holes and other cut-outs are to be avoided in way of concentrated loads and areas of high shear. In particular, manholes and similar openings are not to be cut in vertical or horizontal diaphragm plates in narrow cofferdams or double plate bulkheads within one-third of their length from either end, nor in floors or double bottom girders close to their span ends, or below the heels of pillars, unless the stresses in the plating and the panel buckling characteristics have been calculated and found satisfactory.

5.3.2 Manholes, lightening holes and other openings are to be suitably framed and stiffened where necessary.

5.3.3 Air and drain holes, notches and scallops are to be kept at least 200 mm clear of the toes of end brackets and other areas of high stress. Openings are to be well rounded with smooth edges. Details of scalloped construction are shown in *Figure 10.2.1 Weld dimensions and types*. Closely spaced scallops are not permitted in higher tensile steel members. Widely spaced air or drain holes may be accepted, provided that they are of elliptical shape, or equivalent, to minimise stress concentration and are, in general, cut clear of the weld connection.

5.4 Sheerstrake and bulwarks

5.4.1 Where an angled gunwale is fitted, the top edge of the sheerstrake is to be kept free of all notches and isolated welded fittings. Bulwarks are not to be welded to the top of the sheerstrake within the $0,5L$ amidships.

5.4.2 Where a rounded gunwale is adopted, the welding of fairlead stools and other fittings to this plate is to be kept to the minimum, and the design of the fittings is to be such as to minimise stress concentration.

5.4.3 Arrangements are to ensure a smooth transition from rounded gunwale to angled gunwale towards the ends of the ship.

5.4.4 At the ends of superstructures where the side plating is extended and tapered to align with the bulwark plating, the transition plating is to be suitably stiffened and supported. Where freeing ports or other openings are essential in this plate, they are to be suitably framed and kept well clear of the free edge.

5.5 Fittings and attachments, general

5.5.1 The quality of welding and general workmanship of fittings and attachments as given in *Pt 3, Ch 10, 5.6 Bilge keels and ground bars* and *Pt 3, Ch 10, 5.7 Other fittings and attachments* are to be equivalent to that of the main hull structure. Visual examination of all welds is to be supplemented by non-destructive testing as considered necessary by the Surveyor.

5.6 Bilge keels and ground bars

5.6.1 It is recommended that bilge keels should not be fitted in the forward $0,3L$ region on ships intended to navigate in severe ice conditions.

5.6.2 Bilge keels are to be attached to a continuous ground bar as shown in *Figure 10.5.4 Bilge keel construction*. Butt welds in shell plating, ground bar and bilge keels are to be staggered.

5.6.3 The minimum thickness of the ground bar is to be equal to the thickness of the bilge strake or 14 mm, whichever is the lesser.

5.6.4 The material class, grade and quality of the ground bar are to be in accordance with *Table 2.2.1 Material classes and grades*.

5.6.5 The ground bar is to be connected to the shell with a continuous fillet weld and the bilge keel to the ground bar with a light continuous fillet weld.

5.6.6 Direct connection between ground bar butt welds and shell plating, and between bilge keel butt welds and ground bar is to be avoided.

5.6.7 The design of single web bilge keels is to ensure that failure to the web occurs before failure of the ground bar. In general, this may be achieved by ensuring the web thickness of bilge keels does not exceed that of the ground bar.

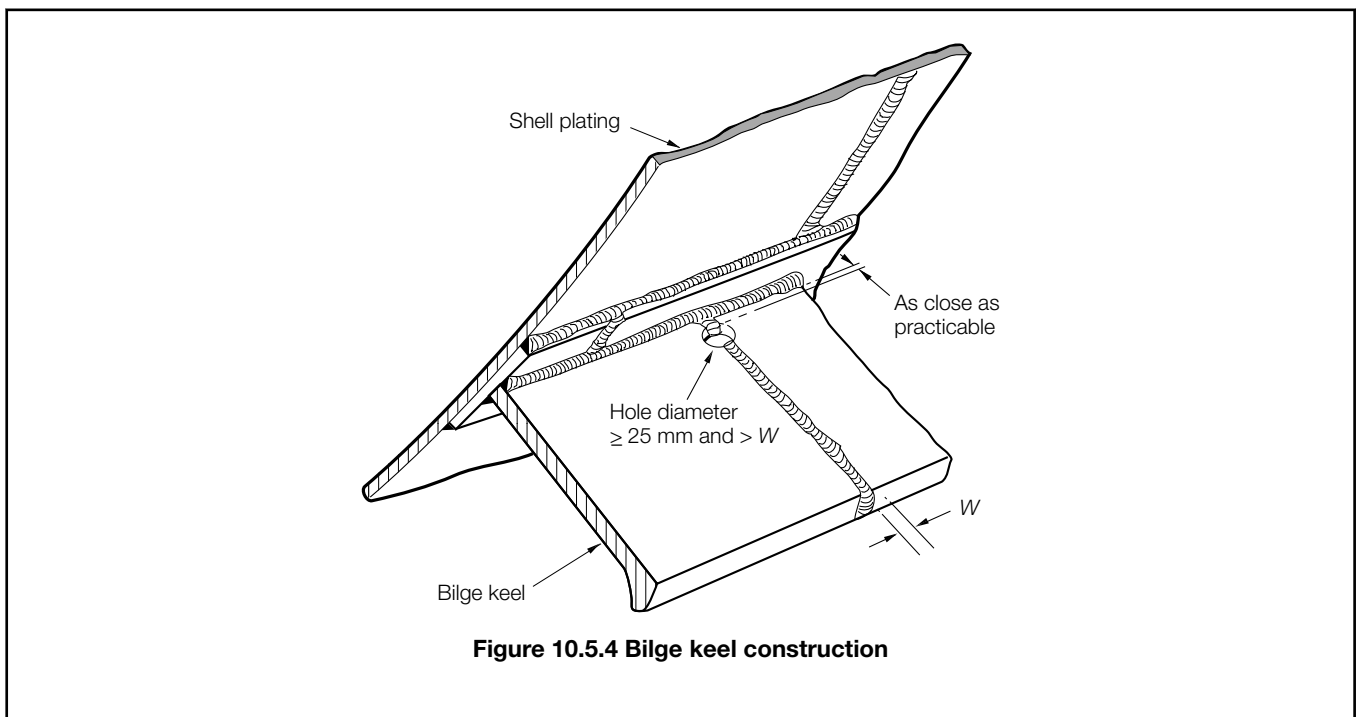

5.6.8 The end details of bilge keels and intermittent bilge keels, where adopted, are to be as shown in *Figure 10.5.5 Bilge keel end design*.

5.6.9 The ground bar and bilge keel ends are to be tapered or rounded. Where the ends are tapered, the tapers are to be gradual with ratios of at least 3:1, see *Figure 10.5.5 Bilge keel end design*. Where the ends are rounded, details are to be as shown in *Figure 10.5.5 Bilge keel end design*. Cut-outs on the bilge keel web within zone 'A' (see *Figure 10.5.5 Bilge keel end design*) are not permitted.

5.6.10 The end of the bilge keel web is to be between 50 mm and 100 mm from the end of the ground bar, see *Figure 10.5.5 Bilge keel end design*.

5.6.11 An internal transverse support is to be positioned as close as possible to halfway between the end of the bilge keel web and the end of the ground bar, see *Figure 10.5.5 Bilge keel end design*.

5.6.12 Where an internal longitudinal stiffener is fitted in line with the bilge keel web, the longitudinal stiffener is to extend to at least the nearest transverse member outside zone 'A', see *Figure 10.5.5 Bilge keel end design*. In this case, the requirement of Pt 3, Ch 10, 5.6 Bilge keels and ground bars 5.6.10 does not apply.

5.6.13 For ships over 65 m in length, holes are to be drilled in the bilge keel butt welds. The size and position of these holes are to be as illustrated in *Figure 10.5.4 Bilge keel construction*. Where the butt weld has been subject to non-destructive examination the stop hole may be omitted.

5.6.14 Bilge keels of a different design from that shown in *Figure 10.5.4 Bilge keel construction* and *Figure 10.5.5 Bilge keel end design* will be specially considered.

5.6.15 Within zone 'B', (see *Figure 10.5.5 Bilge keel end design*), welds at the end of the ground bar and bilge plating, and at the end of the bilge keel web and ground bar, are to have weld factors of 0,44 and 0,34 respectively. These welds are to be ground and to blend smoothly with the base materials.

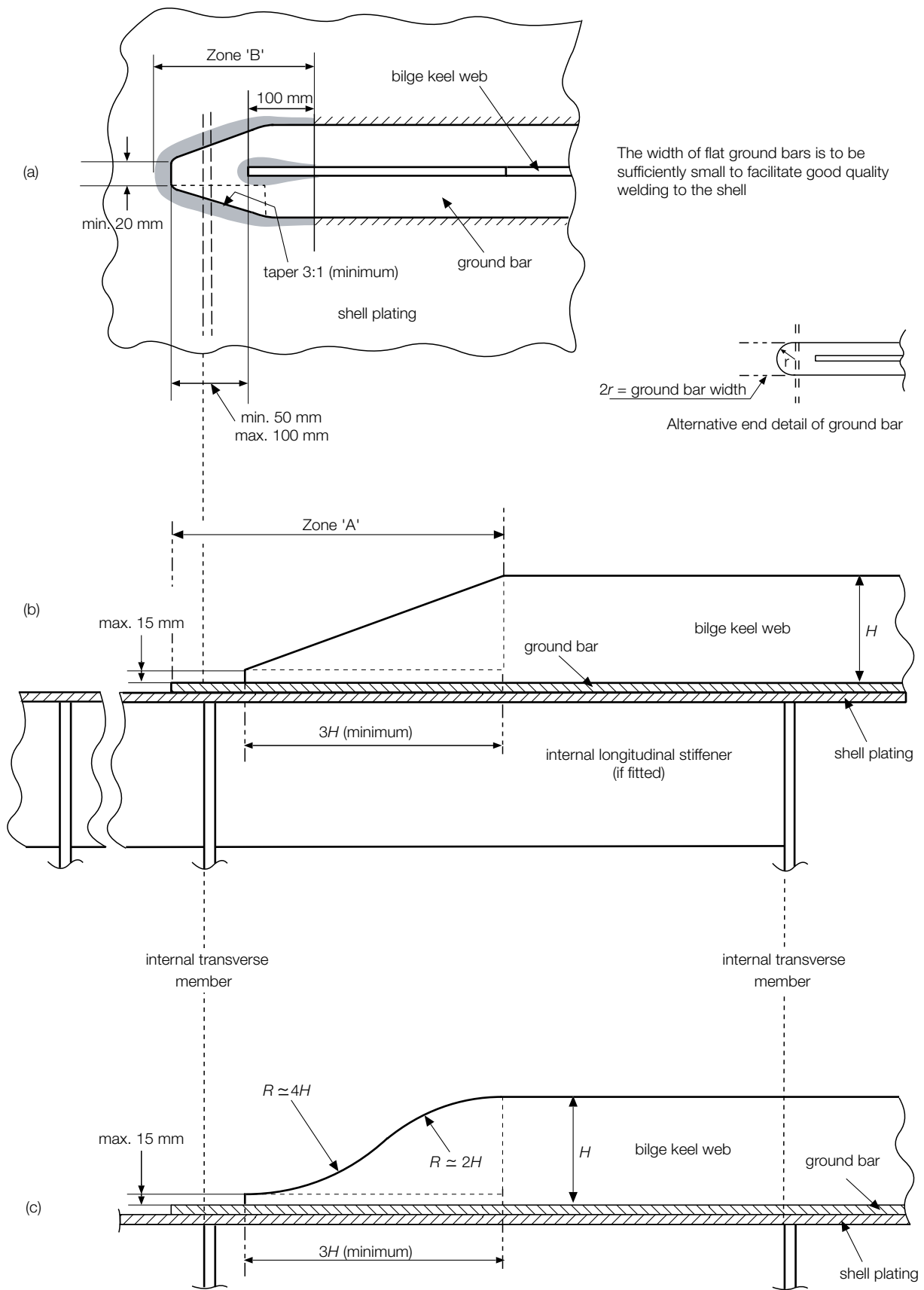

5794/01

Figure 10.5.5 Bilge keel end design

5.6.16 A plan of the bilge keels is to be submitted for approval of material grades, welded connections and detail design.

5.7 Other fittings and attachments

5.7.1 Gutterway bars at the upper deck are to be so arranged that the effect of main hull stresses on them is minimised.

5.7.2 Minor attachments, such as pipe clips, staging lugs and supports, are generally to be kept clear of toes of end brackets, corners of openings and similar areas of high stress. Where connected to asymmetrical stiffeners, the attachments may be in line with the web providing the fillet weld leg length is clear of the offset face plate or flange edge. Where this cannot be achieved the attachments are to be connected to the web, and in the case of flanged stiffeners they are to be kept at least 25 mm clear of the flange edge. On symmetrical stiffeners, they may be connected to the web or to the centreline of the face plate in line with the web.

5.7.3 Where necessary in the construction of the ship, lifting lugs may be welded to the hull plating but they are not to be slotted through. Where they are subsequently removed, this is to be done by flame or mechanical cutting close to the plate surface, and the remaining material and welding ground off. After removal the area is to be carefully examined to ensure freedom from cracks or other defects in the plate surface.

■ *Section 6*

Access arrangements for oil tankers and bulk carriers

6.1 Application

6.1.1 Access arrangements are to be provided as required by SOLAS.

6.2 Information for approval

6.2.1 Details of the attachment of the access arrangements to the ship's structure are to be submitted for approval and suitable designs are to take into account proper location, strength, detail and reinforcement of all attachments to hull structural members.

Section

- 1 **General**
- 2 **Steel hatch covers**
- 3 **Hatch beams and wood covers**
- 4 **Hatch cover securing arrangements and tarpaulins**
- 5 **Hatch coamings**
- 6 **Miscellaneous openings**
- 7 **Tanker access arrangements and closing appliances**
- 8 **Side and stern doors and other shell openings**
- 9 **Watertight doors in bulkheads below the freeboard deck**
- 10 **External openings and openings in watertight bulkheads and internal decks in cargo ships**

■ Section 1 General

1.1 Application

1.1.1 This Chapter applies to all ship types detailed in *Pt 4 Ship Structures (Ship Types)*, unless otherwise stated, with the exception of Sections 1 to 5 which are not applicable to Bulk Carriers with a **CSR** notation and Section *Pt 3, Ch 11, 6.1 Small hatchways on exposed decks* which is not applicable to Bulk Carriers and Oil Tankers with a **CSR** notation, see *Pt 1, Ch 2, 2.3 Class notations (hull)*. Additional provisions regarding access arrangements for oil tankers and chemical carriers are contained in *Pt 4, Ch 9 Double Hull Oil Tankers, Pt 4, Ch 10 Single Hull Oil Tankers* and the *Rules and Regulations for the Construction and Classification of Ships for the Carriage of Liquid Chemicals in Bulk, July 2015* (hereinafter referred to as the Rules for Ships for Liquid Chemicals), respectively.

1.1.2 Requirements are given for steel and wooden hatch covers, securing arrangements, tarpaulins, coamings and side shell doors for main openings, also closing arrangements for other miscellaneous openings.

1.1.3 Where relevant, the contents of this Chapter conform with the requirements of the *Load Lines, 1966/1988 - International Convention on Load Lines, 1966, as Amended by the Protocol of 1988*. Attention should, however, be given to any additional Statutory Requirements of the National Authority of the country in which the ship is to be registered and to the relevant regulations of the *SOLAS - International Convention for the Safety of Life at Sea* and applicable amendments.

1.1.4 For the purpose of this Chapter the basic types of ships are those defined in the *Load Lines, 1966/1988 - International Convention on Load Lines, 1966, as Amended by the Protocol of 1988* namely:

Type 'A'	Ships designed solely for the carriage of liquid cargoes.
Type 'B'	Cargo ships, other than Type 'A', with steel weathertight hatch covers.
Type 'B-100'	Cargo ships of type 'B' with reduced freeboards on account of their ability to survive a stipulated damage.
Type 'B-60'	Cargo ships of type 'B' with reduced freeboards on account of their ability to survive a stipulated damage.
Type 'B +'	Cargo ships with increased freeboard on account of hatch cover arrangements.

1.1.5 The type of hatch covers on the weather decks of the basic ship types defined in *Pt 3, Ch 11, 1.1 Application 1.1.4* are detailed below and may be used in the types of ships as indicated in *Table 11.1.1 Covers associated with ship types*:

- (a) Steel plated cargo hatch covers stiffened by webs or stiffeners and secured by clamping devices. Weathertightness to be achieved by means of gaskets. Hatch covers used for holds containing liquid cargoes are included in this category.
- (b) Steel plated cargo hatch pontoon covers having interior webs and stiffeners extending for the full width of the hatchway. A pontoon cover is defined as a portable cover, secured weathertight by tarpaulins and battening devices.
- (c) Hatch covers of wood or steel used in conjunction with portable beams. Weathertightness to be obtained by tarpaulins.
- (d) Access hatch covers for cargo oil tanks and adjacent spaces. The hatch covers are to be of steel and gasketed.
- (e) Access hatch covers other than (d). For Type 'A', Type 'B-100' and Type 'B-60' ships, the covers are to be of steel, and weathertightness is to be achieved by means of gaskets.

Table 11.1.1 Covers associated with ship types

Type of cover	Type of ship				
	'A'	'B-100'	'B-60'	'B'	'B+'
(a)	–	X	X	X	X
(b)	–	–	–	X	X
(c)	–	–	–	–	X
(d)	X	X	X	Not applicable	
(e)	X	X	X	X	X

1.1.6 The positions of hatches on weather decks are defined in *Pt 3, Ch 1, 6.5 Position 1 and Position 2*.

1.1.7 'Tween deck hatch covers may be any of the types defined in *Pt 3, Ch 11, 1.1 Application 1.1.5*, but need not be weathertight unless fitted to deep tanks or water ballast holds or compartments, in which case the covers are to be of type (a) and oiltight or watertight as appropriate.

1.1.8 The scantlings specified in the following Sections are applicable to covers of mild steel or higher tensile steel. Where other materials are used, equivalent scantlings are to be provided. The scantlings apply basically to rectangular covers, with the stiffening members arranged primarily in one direction and carrying a uniformly distributed load. The covers are assumed to be simply supported. Where covers are stiffened by a grillage formation, and also where point loads are applied to any type of cover, the scantlings are to be determined from direct calculations.

1.1.9 In the case of flush hatch covers or of covers on coamings of lesser height than required by *Pt 3, Ch 11, 5.1 General 5.1.1*, their scantlings, the securing and sealing arrangements and the drainage of gutterways will be specially considered.

1.1.10 The scantlings of hatch covers need to be increased only if the loading exceeds that given in *Pt 3, Ch 11, 2.3 Load model*. The scantlings of the surrounding deck structure are to be sufficient to support this loading. Heavier loading may be permitted only if the scantlings of the cover are capable of withstanding this increased loading, satisfying the stress and deflection criteria given in this Chapter. The deck structure is also to be capable of withstanding this increased loading.

1.1.11 Where timber cargo is to be carried on the hatch covers the requirements of *Pt 3, Ch 9, 2.11 Scantlings of hatch covers* are to be satisfied in addition to the requirements of this Chapter.

1.1.12 Where hatchways are trunked through one or more 'tween decks, and hatchway beams and covers are dispensed with at the intermediate decks, the hatchway beams, coamings and covers immediately below the trunk are to be adequately strengthened. Plans are to be submitted for approval.

1.1.13 The net plate thickness, t_{net} , is the calculated minimum thickness of the plating and stiffeners. The required thickness is the net thickness plus a corrosion addition, t_c , given in *Table 11.1.2 Corrosion addition t_c* .

Table 11.1.2 Corrosion addition t_c

Application	Structure	t_c , in mm
Weather deck hatches of container ships, car carriers, paper carriers, passenger vessels	Hatch covers	1,0
	Hatch coamings	1,0

Weather deck hatches of all other ship types except bulk carriers, ore carriers and combination carriers, see Pt 4, Ch 7, 12.1 General 12.1.2	Hatch covers in general	2,0
	Weather exposed plating and bottom plating of double skin hatch covers	1,5
	Internal structure of double skin hatch covers and closed box girders	1,0
	Hatch coamings	1,5
Weather deck hatches of all other ship types except bulk carriers, ore carriers and combination carriers, see Pt 4, Ch 7, 12.1 General 12.1.2	Coaming stays and stiffeners	1,5
'Tween deck hatches	Hatch covers in general	1,0

■ Section 2 Steel hatch covers

2.1 General

2.1.1 The requirements of Pt 3, Ch 11, 2 Steel hatch covers are not applicable to hatch covers of bulk carriers, ore carriers and combination carriers.

2.1.2 The strength requirements in Pt 3, Ch 11, 2.1 General to Pt 3, Ch 11, 2.16 Torsional buckling of secondary stiffeners are applicable to hatch covers and closing arrangements of stiffened plate construction. The strength requirements are applicable to exposed weather deck hatch covers and 'tween deck hatch covers, unless otherwise stated.

2.1.3 Sub-Sections Pt 3, Ch 11, 2.1 General to Pt 3, Ch 11, 2.16 Torsional buckling of secondary stiffeners are not applicable to portable covers secured weathertight by tarpaulins and battening devices, or pontoon covers, see Pt 3, Ch 11, 2.17 Pontoon covers.

2.1.4 Unless otherwise stated, the thicknesses referred to in the following Sections are net thicknesses. The net thicknesses are the member thicknesses necessary to obtain the minimum net scantlings required in this Section. The required gross thicknesses are obtained by adding corrosion additions, t_c , given in Table 11.1.2 Corrosion addition t_c . Strength calculations using beam theory, grillage analysis or FEM are to be performed with net scantlings.

2.1.5 Material class I is to be applied for hatch covers.

2.1.6 The strength and closing arrangements of hatch covers are to comply with Pt 4, Ch 7, 12 Steel hatch covers in addition to the requirements in this Chapter when hatch covers are subjected to internal ballast or oil cargo pressure.

2.1.7 Hatch covers are to comply with Pt 4, Ch 8, 11 Hatch covers in addition to the requirements in this Chapter when containers are carried on covers.

2.2 Stiffener arrangement

2.2.1 The primary supporting members and secondary stiffeners of hatch covers are to be continuous over the breadth and length of hatch covers, as far as practical. When this is impractical, sniped end connections are not to be used and appropriate arrangements are to be adopted to ensure sufficient load-carrying capacity.

2.2.2 The spacing of primary supporting members parallel to the direction of secondary stiffeners is not to exceed one third of the span of primary supporting members. When strength calculation is carried out by FE analysis using plane strain or shell elements, this requirement can be waived.

2.3 Load model

2.3.1 The structural assessment of hatch covers is to be carried out using the design loads defined in this Section. The following symbols and definitions are applicable to this Section:

x = longitudinal co-ordinate measured from the AP to mid point of assessed structural member

T_{fb} = draught, in metres, corresponding to the assigned summer load line

$$\begin{aligned}
 h_N &= \text{standard superstructure height in metres} \\
 &= 1,05 + 0,01L_L, 1,8 \leq h_N \leq 2,3
 \end{aligned}$$

where

$$L_L = \text{load line length, as defined in Pt 3, Ch 1, 6.1 Principal particulars 6.1.8.}$$

2.3.2 The vertical weather design pressure, p_H , in kN/m^2 , on the hatch cover panels is to be taken from *Table 11.2.1 Design pressure p_H of weather deck hatches*. When cargo is carried on the cover, cargo loads according to *Pt 3, Ch 11, 2.3 Load model 2.3.4*, *Pt 3, Ch 11, 2.3 Load model 2.3.5* and *Pt 4, Ch 8, 11.2 Direct calculations* are to be considered. The vertical weather design load needs not to be combined with the cargo load. For 'tween deck hatch covers not exposed to weather load, the structural assessment is to be carried out using the cargo loads defined in *Pt 3, Ch 11, 2.3 Load model 2.3.4* and *Pt 3, Ch 11, 2.3 Load model 2.3.5*. Covers carrying wheeled vehicles are also to comply with *Pt 3, Ch 9, 3 Decks loaded by wheeled vehicles* and where it is proposed to provide a helicopter landing area, covers are also to comply with *Pt 3, Ch 9, 5 Helicopter landing areas*. Where an increased freeboard is assigned, the design load for hatch covers according to *Table 11.2.1 Design pressure p_H of weather deck hatches* on the actual freeboard deck may be as required for a superstructure deck, provided the summer freeboard is such that the resulting draught will not be greater than that corresponding to the minimum freeboard calculated from an assumed freeboard deck situated at a distance at least equal to the standard superstructure height, h_N , below the actual freeboard deck, see *Figure 11.2.2 Positions 1 and 2 for an increased freeboard*.

Table 11.2.1 Design pressure p_H of weather deck hatches

Position (see Note)	p_H , in kN/m ²		
1	$\frac{x}{L_L} \leq 0,75$	$0,75 < \frac{x}{L_L} \leq 1,0$	
	for $24 \text{ m} \leq L_L \leq 100 \text{ m}$		
	$\frac{g}{76} (1,5L_L + 116)$	on freeboard deck	$\frac{g}{76} \left[(4,28L_L + 28) \frac{x}{L_L} - 1,71L_L + 95 \right]$
		upon exposed superstructure decks located at least one superstructure standard height above the freeboard deck	
	for $L_L > 100 \text{ m}$		
	3,5g	on freeboard deck for type B ships according to ICLL	$g \left[(0,0296L_1 + 3,04) \frac{x}{L_L} - 0,0222L_1 + 1,22 \right]$
on freeboard deck for ships with less freeboard than type B according to ICLL		$g \left[(0,1452L_1 - 8,52) \frac{x}{L_L} - 0,1089L_1 + 9,89 \right]$	
		$L_1 = L_L$ but not more than 340 m	
		upon exposed superstructure decks located at least one superstructure standard height above the freeboard deck	
		3,5g	
2	for $24 \text{ m} \leq L_L \leq 100 \text{ m}$		
	$\frac{g}{76} (1,1L_L + 87,6)$		
	for $L_L > 100 \text{ m}$		
	2,6g		
		upon exposed superstructure decks located at least one superstructure standard height above the lowest Position 2 deck	
		2,1g	
Symbols			
L_L = load line length, as defined in Pt 3, Ch 1, 6.1 Principal particulars 6.1.8			
g = acceleration due to gravity, 9,81 m/s ²			
Note The positions 1 and 2 are illustrated for example ships in Figure 11.2.1 Positions 1 and 2 and Figure 11.2.1 Positions 1 and 2.			

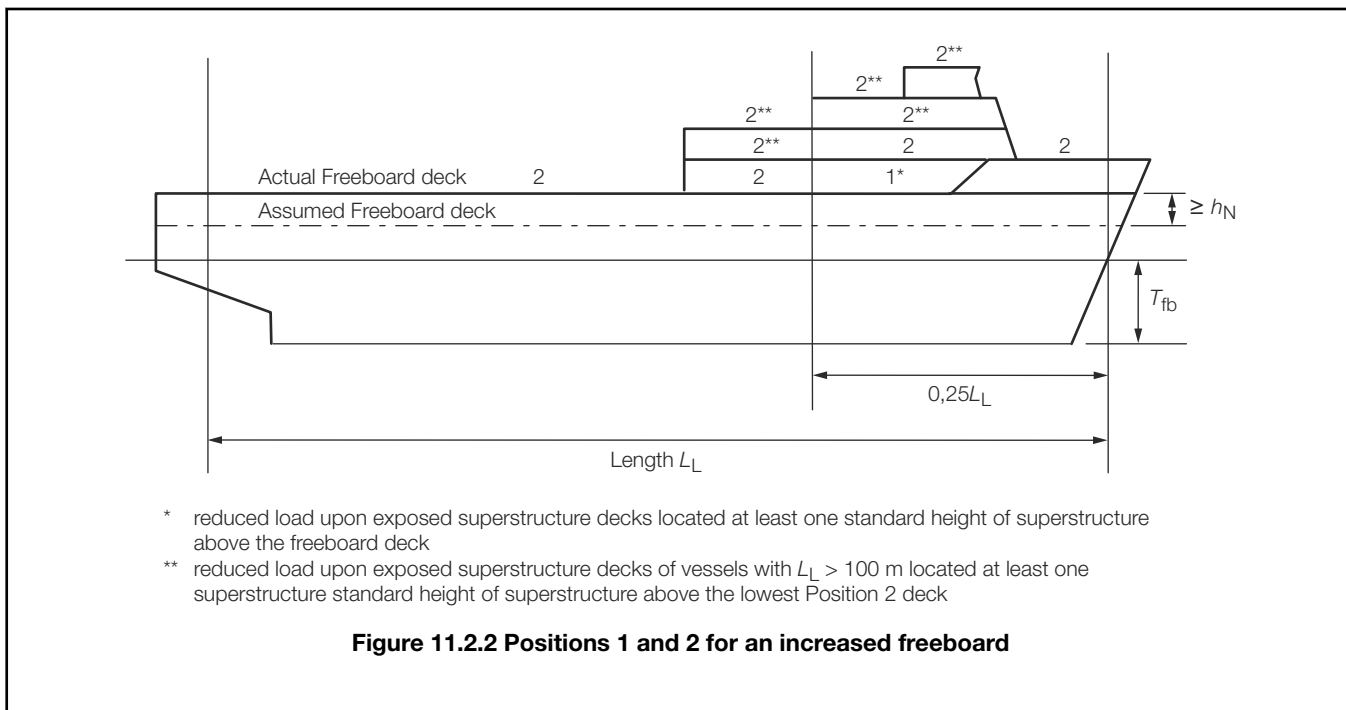
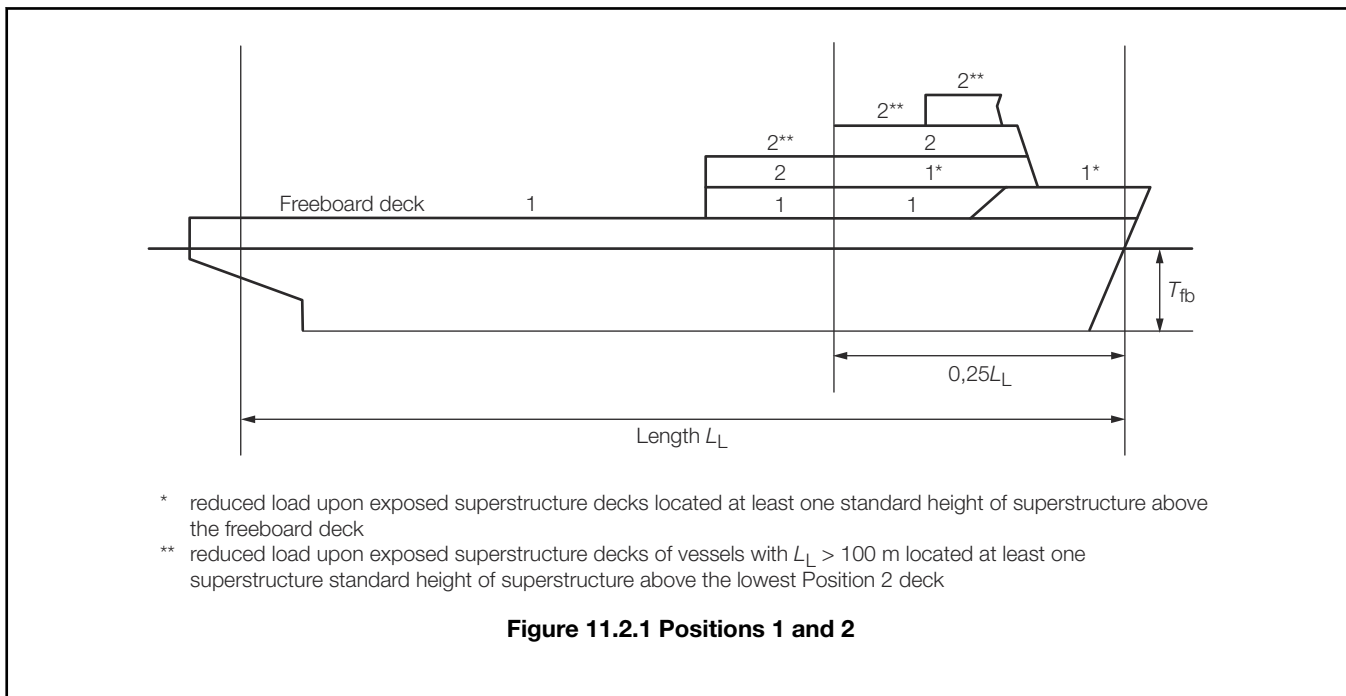

2.3.3 The horizontal weather design pressure, in kN/m^2 , for determining the scantlings of outer edge girders (skirt plates) of weather deck hatch covers and of hatch coamings is:

$$p_A = a c (b c_L f - z) \text{ kN/m}^2$$

$$f = \frac{L}{25} + 4,1 \text{ for } L < 90 \text{ m}$$

$$= 10,75 - \left(\frac{300 - L}{100}\right)^{1,5} \text{ for } 90 \text{ m} \leq L < 300 \text{ m}$$

$$= 10,75 \text{ for } 300 \text{ m} \leq L < 350 \text{ m}$$

$$= 10,75 - \left(\frac{L - 350}{100} \right)^{1,5} \text{ for } 350 \text{ m} \leq L \leq 500 \text{ m}$$

$$c_L = \sqrt{\frac{L}{90}} \text{ for } L < 90 \text{ m}$$

$$= 1$$

$$a = 1 \text{ for unprotected front coamings and hatch cover skirt plates}$$

$$= 1$$

$$= 20 + \frac{L_1}{12} \text{ for unprotected front coamings and hatch cover skirt plates}$$

$$a = 10 + \frac{L_1}{12} \text{ for unprotected front coamings and hatch cover skirt plates, where the distance from the actual freeboard deck to the summer load line exceeds the minimum non-corrected tabular freeboard according to ICLL by at least one standard superstructure height } h_N$$

$$a = 5 + \frac{L_1}{15} \text{ for side and protected front coamings and hatch cover skirt plates}$$

$$a = 7 + \frac{L_1}{100} - 8 \frac{x'}{L} \text{ for aft ends of coamings and aft hatch cover skirt plates abaft amidships}$$

$$a = 5 + \frac{L_1}{100} - 4 \frac{x'}{L} \text{ for aft ends of coamings and aft hatch cover skirt plates forward of amidships}$$

$$L_1 = L, \text{ need not be taken greater than } 300 \text{ m}$$

$$b = 1,0 + \left(\frac{\frac{x'}{L} - 0,45}{C_b + 0,2} \right)^2 \text{ for } \left(\frac{x'}{L} \right) < 0,45$$

$$b = 1,0 + 1,5 \left(\frac{\frac{x'}{L} - 0,45}{C_b + 0,2} \right)^2 \text{ for } \left(\frac{x'}{L} \right) \geq 0,45$$

$$= 0,6 \leq C_b \leq 0,8, \text{ when determining scantlings of aft ends of coamings and aft hatch cover skirt plates forward of amidships, } C_b \text{ need not be taken less than } 0,8$$

$$C_b = \text{block coefficient, as defined in Pt 3, Ch 1, 6.1 Principal particulars 6.1.6}$$

$$x' = \text{distance, in metres, between the transverse coaming or hatch cover skirt plate considered and aft end of the length } L. \text{ When determining side coamings or side hatch cover skirt plates, the side is to be subdivided into parts of approximately equal length, not exceeding } 0,15L \text{ each, and } x' \text{ is to be taken as the distance between aft end of the length } L \text{ and the centre of each part considered}$$

$$z = \text{vertical distance in metres from the summer load line to the mid point of stiffener span, or to the middle of the plate field}$$

$$c = 0,3 + 0,7 \frac{b'}{B'}$$

$$b' = \text{breadth of coaming in metres at the position considered}$$

B' = actual maximum breadth of ship in metres on the exposed weather deck at the position considered
 b'/B' is not to be taken less than 0,25

The design pressure p_A is not to be taken less than the minimum values given in *Table 11.2.2 Minimum design load, p_{Amin}* .

Table 11.2.2 Minimum design load, p_{Amin}

L	p_{Amin} , kN/m ²	
	For unprotected fronts	Elsewhere
≤ 50	30	15
> 50	$25 + \frac{L}{10}$	$12,5 + \frac{L}{20}$
< 250		
≥ 250	50	25

2.3.4 The pressure on hatch covers due to distributed cargo loads p_L , in kN/m², resulting from heave and pitch, is to be determined according to the following formula:

$$p_L = p_c(1 + a_v) \text{ kN/m}^2$$

where

p_c = uniform cargo load, in kN/m²

Note For 'tween deck hatch covers, p_c is not to be taken less than $7,07 H_{td}$ kN/m², see *Pt 3, Ch 3, 5.2 Symbols 5.2.1, Table 3.5.1 Design heads and permissible cargo loadings and Figure 3.5.1 Heads for 'tween decks*. A design load less than this will be specially considered.

a_v = acceleration addition as follows:

$$a_v = F m$$

$$F = 0,11 \sqrt{\frac{v_0}{L}}$$

$$m = m_0 - 5(m_0 - 1) \frac{x}{L} \text{ for } 0 \leq \frac{x}{L} \leq 0,2$$

$$= 1,0 \text{ for } 0,2 < \frac{x}{L} \leq 0,7$$

$$= 1 + \frac{m_0 + 1}{0,3} \left(\frac{x}{L} - 0,7 \right) \text{ for } 0,7 < \frac{x}{L} \leq 1,0$$

$$m_0 = 1,5 + F$$

v_0 = Maximum speed at summer load line draught, v_0 is not to be taken less than \sqrt{L} , in knots.

2.3.5 Point loads due to single forces, P , in kN resulting from heave and pitch are to be determined as follows:

$$P = P_s(1 + a_v) \text{ kN}$$

P_s = single force, in kN.

2.3.6 In addition to the loads defined in this Section, hatch covers are loaded in the ship's transverse direction by forces due to elastic deformations of the ship's hull. Hatch covers are to be designed such that the sum of stresses does not exceed the permissible values given in *Pt 3, Ch 11, 2.4 Allowable stress and deflection 2.4.1*.

2.4 Allowable stress and deflection

2.4.1 The equivalent stress, σ_v , in steel hatch cover structures related to the net thickness shall not exceed $0,8\sigma_0$, where σ_0 is the minimum yield stress, in N/mm², of the material. For design loads according to *Pt 3, Ch 11, 2.3 Load model 2.3.3* and *Pt 4, Ch 8, 11.2 Direct calculations*, the equivalent stress, σ_v , related to the net thickness shall not exceed $0,9\sigma_0$ when the stresses are assessed by means of FEM using plane stress or shell elements.

For beam element calculations and grillage analysis, the equivalent stress may be taken as follows:

$$\sigma_v = \sqrt{\sigma^2 + 3\tau^2}, \text{ in N/mm}^2$$

σ = normal stress in N/mm²

τ = shear stress in N/mm²

For FEM calculations, the equivalent stress may be taken as follows:

$$\sigma_v = \sqrt{\sigma_x^2 - \sigma_x\sigma_y + \sigma_y^2 + 3\tau^2}, \text{ N/mm}^2$$

σ_x = normal stress, in N/mm², in x-direction

σ_y = normal stress, in N/mm², in y-direction

τ = shear stress, in N/mm², in the x-y plane

Indices x and y are coordinates of a two-dimensional Cartesian system in the plane of the considered structural element.

In the case of FEM calculations using shell or plane strain elements, the stresses are to be read from the centre of the individual element. Where shell elements are used, the stresses are to be evaluated at the mid plane of the element. Stress concentrations are to be considered. FEM calculations are to be carried out in accordance with the ShipRight procedure *Assessment of Steel Hatch Covers using Finite Element Analysis*.

2.4.2 The vertical deflection of primary supporting members due to the vertical weather design load according to *Pt 3, Ch 11, 2.3 Load model 2.3.2*, is to be not more than $0,0056l_g$ where l_g is the greatest span of primary supporting members.

For 'tween deck hatch covers not exposed to the vertical weather design load according to *Pt 3, Ch 11, 2.3 Load model 2.3.2*, the vertical deflection of primary supporting members due to the cargo loads according to *Pt 3, Ch 11, 2.3 Load model 2.3.4*, *Pt 3, Ch 11, 2.3 Load model 2.3.5* and *Pt 4, Ch 8, 11.2 Direct calculations* is to be not more than $0,007l_g$ where l_g is the greatest span of primary supporting members.

2.5 Local net plate thickness

2.5.1 The local net plate thickness, t , in mm, of the hatch cover top plating is not to be less than:

$$t = F_p 0,0158s \sqrt{\frac{p}{0,95\sigma_0}}$$

and to be not less than 1 per cent of the spacing of the stiffener or 6 mm, whichever is greater

F_p = factor for combined membrane and bending response

= 1,5 in general

= $1,9 \frac{\sigma}{\sigma_a}$, for $\frac{\sigma}{\sigma_a} \geq 0,8$

for the attached plate flange of primary supporting members

s = stiffener spacing, in mm

p = pressure p_H and p_L , in kN/m², as defined in *Pt 3, Ch 11, 2.3 Load model*

σ = normal stress, in N/mm², of hatch cover top plating

$$\sigma_a = 0,8\sigma_o, \text{ in N/mm}^2$$

For flange plates under compression, sufficient buckling strength according to Pt 3, Ch 11, 2.11 *Buckling strength of hatch cover structures* is to be demonstrated.

The normal stress σ of the hatch cover plating may be determined in a distance s from webs of adjacent primary supporting members perpendicular to secondary stiffeners, and in a distance $s/2$ from the web of an adjacent primary supporting member parallel to secondary stiffeners, see Figure 11.2.3 *Determination of normal stress of the hatch cover plating*. The greater of both stresses is to be taken. For the distribution of normal stress σ between two parallel girders, see Pt 3, Ch 11, 2.14 *Effective width of top and lower hatch cover plating* 2.14.1.

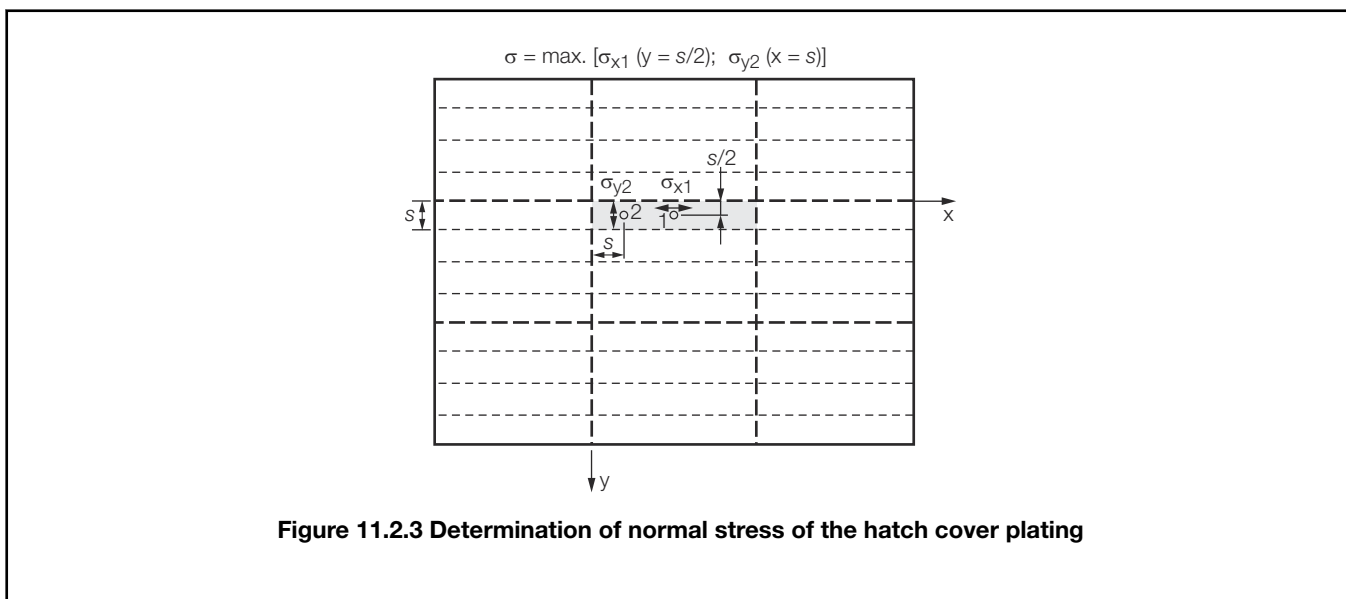

2.6 Local plate thickness of hatch covers for wheel loading and helicopter landing

2.6.1 The local gross plate thickness of hatch covers for wheel loading is to comply with Pt 3, Ch 9, 3 *Decks loaded by wheeled vehicles*.

2.6.2 The local gross plate thickness of hatch covers for helicopter landing is to comply with Pt 3, Ch 9, 5 *Helicopter landing areas*.

2.7 Lower plating of double skin hatch covers and box girders

2.7.1 The thickness to fulfil the strength requirements is to be obtained from the calculation according to Pt 3, Ch 11, 2.10 *Strength calculations* under consideration of permissible stresses according to Pt 3, Ch 11, 2.4 *Allowable stress and deflection* 2.4.1. The net thickness must not be less than the larger of the following values when the lower plating is taken into account as a strength member of the hatch cover:

$$t = 0,0065s, \text{ in mm}$$

$$t_{\min} = 5 \text{ mm}$$

s = stiffener spacing, in mm.

2.8 Net scantling of secondary stiffeners

2.8.1 The net section modulus, Z , and net shear area, A_s , of uniformly loaded hatch cover stiffeners constrained at both ends is not to be less than:

$$Z = \frac{0,104}{\sigma_o} sl^2 p, \text{ in cm}^3$$

$$A_s = \frac{0,01}{\sigma_0} s l p, \text{ in cm}^2$$

where

l = secondary stiffener span, in metres, to be taken as the spacing, in metres, of primary supporting members or the distance between a primary supporting member and the edge support, as applicable

s = secondary stiffener spacing, in mm

p = pressure p_H and p_L , in kN/m^2 , as defined in *Pt 3, Ch 11, 2.3 Load model*.

2.8.2 The net section modulus of the secondary stiffeners is to be determined, based on an attached plate width assumed equal to the stiffener spacing.

2.8.3 For flat bar secondary stiffeners and buckling stiffeners, the ratio h/t_w is to be not greater than $15k^{0,5}$

where

h = height of the stiffener

t_w = net thickness of the stiffener

$k = 235/\sigma_0$.

2.8.4 Stiffeners parallel to primary supporting members and arranged within the effective breadth according to *Pt 3, Ch 11, 2.10 Strength calculations* must be continuous when crossing primary supporting members and may be considered when calculating the cross-sectional properties of primary supporting members. It is to be verified that the combined stress of those stiffeners, induced by the bending of primary supporting members and lateral pressures, does not exceed the permissible stresses according to *Pt 3, Ch 11, 2.4 Allowable stress and deflection 2.4.1*.

2.8.5 For hatch cover stiffeners under compression, sufficient safety against lateral and torsional buckling according to *Pt 3, Ch 11, 2.15 Lateral buckling of secondary stiffeners* and *Pt 3, Ch 11, 2.16 Torsional buckling of secondary stiffeners* is to be verified.

2.8.6 For hatch covers subject to wheel loading, stiffener gross scantlings are to comply with *Pt 3, Ch 9, 3 Decks loaded by wheeled vehicles*.

2.8.7 For hatch covers subject to helicopter landing, stiffener gross scantlings are to comply with *Pt 3, Ch 9, 5 Helicopter landing areas*.

2.9 Net scantling of primary supporting members

2.9.1 Scantlings of primary supporting members are obtained from calculations according to *Pt 3, Ch 11, 2.10 Strength calculations*, under consideration of permissible stresses according to *Pt 3, Ch 11, 2.4 Allowable stress and deflection 2.4.1*.

2.9.2 For all components of primary supporting members, sufficient safety against buckling must be verified according to *Pt 3, Ch 11, 2.11 Buckling strength of hatch cover structures* to *Pt 3, Ch 11, 2.16 Torsional buckling of secondary stiffeners*. For biaxial compressed flange plates, this is to be verified within the effective widths according to *Pt 3, Ch 11, 2.14 Effective width of top and lower hatch cover plating 2.14.1*.

2.9.3 The net thickness, t , in mm, of webs of primary supporting members is not to be less than:

(a) $0,0065s$, in mm

(b) 5 mm

where

s = stiffener spacing, in mm.

2.9.4 Scantlings of edge girders (skirt plates) are obtained from the calculations according to *Pt 3, Ch 11, 2.10 Strength calculations*, under consideration of permissible stresses according to *Pt 3, Ch 11, 2.4 Allowable stress and deflection 2.4.1*.

2.9.5 The net thickness, t , in mm, of the outer edge girders exposed to wash of sea is not to be less than the largest of the following values:

(a) $0,0158s \sqrt{\frac{p_A}{0,95 \sigma_o}}$

(b) $0,0085s$ mm

(c) 5 mm

where

p_A = horizontal pressure, as defined in Pt 3, Ch 11, 2.3 Load model 2.3.3

s = stiffener spacing, in mm.

2.9.6 The stiffness of edge girders is to be sufficient to maintain adequate sealing pressure between securing devices. The moment of inertia, in cm^4 , of edge girders is not to be less than:

$$I = 6q s_{SD}^4$$

q = packing line pressure, in N/mm, minimum 5 N/mm

s_{SD} = spacing, in metres, of securing devices.

2.10 Strength calculations

2.10.1 Strength calculation for hatch covers may be carried out by using either beam theory, grillage analysis or FEM.

2.10.2 The effective cross-sectional properties for calculation by beam theory or grillage analysis are to be determined considering the effective breadth. Cross-sectional areas of secondary stiffeners parallel to the primary supporting member under consideration within the effective breadth can be included, see Figure 11.2.5 *Stiffening parallel to web of primary supporting member*. The effective breadth of plating, e_m , of primary supporting members is to be determined according to Table 11.2.3 *Effective breadth e_m of plating of primary supporting members*, considering the type of loading. Special calculations may be required for determining the effective breadth of one-sided or non-symmetrical flanges. The effective cross-sectional area of plates is not to be less than the cross-sectional area of the face-plate. For flange plates under compression with secondary stiffeners perpendicular to the web of the primary supporting member, the effective width is to be determined according to Pt 3, Ch 11, 2.14 *Effective width of top and lower hatch cover plating 2.14.1*.

Table 11.2.3 Effective breadth e_m of plating of primary supporting members

l/e	0	1	2	3	4	5	6	7	≥ 8
e_{m1}/e	0	0,36	0,64	0,82	0,91	0,96	0,98	1,00	1,00
e_{m2}/e	0	0,20	0,37	0,52	0,65	0,75	0,84	0,89	0,90
Symbols									
e_{m1}	is to be applied where primary supporting members are loaded by uniformly distributed loads or else by no fewer than six equally spaced single loads								
e_{m2}	is to be applied where primary supporting members are loaded by three or fewer single loads. Intermediate values may be obtained by direct interpolation								
l	length of zero-points of bending moment curve: $l = l_0$ for simply supported primary supporting members $l = 0,6 l_0$ for primary supporting members with both ends constrained								
where									
l_0	is the unsupported length of the primary supporting member								
e	width of plating supported, measured from centre to centre of the adjacent unsupported fields								

2.11 Buckling strength of hatch cover structures

2.11.1 For hatch cover structures, sufficient buckling strength is to be demonstrated.

a = length of the longer side of a single plate field, in mm

b = breadth of the shorter side of a single plate field, in mm

α = aspect ratio of single plate field

$$= a/b$$

n = number of single plate field breadths within the partial or total plate field

t = net plate thickness, in mm

σ_x = membrane stress, in N/mm², in x-direction

σ_y = membrane stress, in N/mm², in y-direction

τ = shear stress, in N/mm², in the x-y plane

E = modulus of elasticity, in N/mm², of the material

$$= 2,06 \times 10^5 \text{ N/mm}^2 \text{ for steel}$$

σ_F = minimum yield stress, in N/mm², of the material.

Compressive and shear stresses are to be taken positive, tension stresses are to be taken negative.

If stresses in the x- and y-direction already contain the Poisson effect (calculated using FEM), the following modified stress values may be used. Both stresses σ_x^* and σ_y^* are to be compressive stresses, in order to apply the stress reduction according to the following formulae.

$$\sigma_x = \frac{(\sigma_x^* - 0,3 \sigma_y^*)}{0,91}$$

$$\sigma_y = \frac{(\sigma_y^* - 0,3 \sigma_x^*)}{0,91}$$

σ_x^*, σ_y^* = stresses containing the Poisson effect where compressive stress fulfils the condition

$$\sigma_y^* < 0,3 \sigma_x^*, \text{ then } \sigma_y = 0 \text{ and } \sigma_x = \sigma_x^*$$

where compressive stress fulfils the condition

$$\sigma_x^* < 0,3 \sigma_y^*, \text{ then } \sigma_x = 0 \text{ and } \sigma_y = \sigma_y^*$$

F_1 = correction factor for boundary condition at the longitudinal stiffeners according to *Table 11.2.4*
Correction factor F_1

σ_e = reference stress, in N/mm², taken equal to

$$= 0,9E \left(\frac{t}{b}\right)^2$$

ψ = edge stress ratio taken equal to

$$= \frac{\sigma_2}{\sigma_1}$$

where

σ_1 = maximum compressive stress

σ_2 = minimum compressive stress or tension stress

S = safety factor (based on net scantling approach), taken equal to

= 1,25 for hatch covers when subjected to the vertical weather design load according to Pt 3, Ch 11, 2.3 Load model 2.3.2

= 1,10 for hatch covers when subjected to loads according to Pt 3, Ch 11, 2.3 Load model 2.3.3 and Pt 4, Ch 8, 11.2 Direct calculations

λ = reference degree of slenderness, taken equal to:

$$= \sqrt{\frac{\sigma_o}{K \sigma_e}}$$

K = buckling factor according to Table 11.2.6 Buckling and reduction factors for plane elementary plate panels.

Table 11.2.4 Correction factor F_1

Stiffeners sniped at both ends	1,00	
Guidance values, see Note 1, where both ends are effectively connected to adjacent structures	1,05	for flat bars
	1,10	for bulb sections
	1,21	for angle and tee-sections
	1,30	for u-type sections, see Note 2, and girders of high rigidity
An average value of F , see Note 1, is to be used for plate panels having different edge stiffeners		
Note 1. Exact values may be determined by direct calculations.		
Note 2. A higher value, but not greater than 2,0, may be taken if it is verified by a buckling strength check of the partial plate field using non-linear FEA. The calculations are to be submitted to LR for approval.		

Table 11.2.5 Coefficients e_1, e_2, e_3 and factor B

Exponents e_1 to e_3 and factor B	Plate panel
e_1	$1 + \kappa_x^4$
e_2	$1 + \kappa_y^4$
e_3	$1 + \kappa_x \kappa_y \kappa_\tau^2$
B σ_x and σ_y positive (compression stress)	$(\kappa_x \kappa_y)^5$
B σ_x or σ_y negative (tension stress)	1

2.11.2 Proof is to be provided that the following condition is complied with for the single plate field a b :

$$\left(\frac{|\sigma_x| S}{\kappa_x \sigma_o} \right) e_1 + \left(\frac{|\sigma_y| S}{\kappa_y \sigma_o} \right) e_2 - B \left(\frac{\sigma_x \sigma_y S^2}{\sigma_o^2} \right) + \left(\frac{|\tau| S \sqrt{3}}{\kappa_\tau \sigma_o} \right) e_3 \leq 1,0$$

Closing Arrangements for Shell, Deck and Bulkheads

Part 3, Chapter 11

Section 2

The first two terms and the last term of the above condition shall not exceed 1,0.

The reduction factors κ_x , κ_y and κ_t are given in Table 11.2.6 *Buckling and reduction factors for plane elementary plate panels*.

Where $\sigma_x \leq 0$ (tension stress), $\kappa_x = 1,0$.

Where $\sigma_y \leq 0$ (tension stress), $\kappa_y = 1,0$.

The exponents e_1 , e_2 and e_3 as well as the factor B are to be taken as given by Table 11.2.5 *Coefficients e_1 , e_2 , e_3 and factor B* .

Table 11.2.6 Buckling and reduction factors for plane elementary plate panels

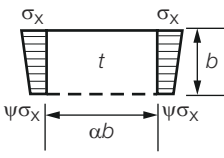
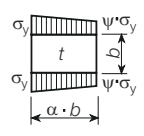
Buckling load case	Edge stress ratio ψ	Asp. ratio $\alpha = \frac{a}{b}$	Buckling factor K	Reduction factor κ
	$1 \geq \psi \geq 0$	$\alpha \geq 1$	$K = \frac{8,4}{\psi + 1,1}$	$\kappa_x = 1$ for $\lambda \leq \lambda_c$
	$0 > \psi > -1$		$K = 7,63 - \psi (6,26 - 10\psi)$	$\kappa_x = c \left(\frac{1}{\lambda} - \frac{0,22}{\lambda^2} \right)$ for $\lambda > \lambda_c$
	$\psi \leq -1$		$K = 5,975 (1 - \psi)^2$	$c = (1,25 - 0,12\psi) \leq 1,25$ $\lambda_c = \frac{c}{2} \left(1 + \sqrt{1 - \frac{0,88}{c}} \right)$
	$1 \geq \psi \geq 0$	$\alpha \geq 1$	$K = F_1 \left(1 + \frac{1}{\alpha^2} \right)^2 \frac{2,1}{(\psi + 1,1)}$	$\kappa_y = c \left(\frac{1}{\lambda} - \frac{R + F^2(H - R)}{\lambda^2} \right)$ $c = (1,25 - 0,12\psi) \leq 1,25$ $R = \lambda \left(1 - \frac{\lambda}{c} \right)$ for $\lambda < \lambda_c$
	$0 > \psi > -1$	$1 \leq \alpha \leq 1,5$	$K = F_1 \left[\left(1 + \frac{1}{\alpha^2} \right)^2 \frac{2,1(1 + \psi)}{1,1} - \frac{\psi}{\alpha^2} (13,9 - 10\psi) \right]$	$R = 0,22$ for $\lambda \geq \lambda_c$ $\lambda_c = \frac{c}{2} \left(1 + \sqrt{1 - \frac{0,88}{c}} \right)$ $F = \left(1 - \frac{\kappa}{\lambda_p^2} \right) c_1 \geq 0$
		$\alpha > 1,5$	$K = F_1 \left[\left(1 + \frac{1}{\alpha^2} \right)^2 \frac{2,1(1 + \psi)}{1,1} - \frac{\psi}{\alpha^2} \left(5,87 + 1,87\alpha^2 + \frac{8,6}{\alpha^2} - 10\psi \right) \right]$	$\lambda_p^2 = \lambda^2 - 0,5$ for $1 \leq \lambda_p^2 \leq 3$ $c_1 = \left(1 - \frac{F_1}{\alpha} \right) \geq 0$
	$\psi \leq -1$	$1 \leq \alpha \leq \frac{3(1 - \psi)}{4}$	$K = 5,975 F_1 \left(\frac{1 - \psi}{\alpha} \right)^2$	$H = \lambda - \frac{2\lambda}{c(T + \sqrt{T^2 - 4})} \geq R$
		$\alpha > \frac{3(1 - \psi)}{4}$	$K = F_1 \left[3,9675 \left(\frac{1 - \psi}{\alpha} \right)^2 + 0,5375 \left(\frac{1 - \psi}{\alpha} \right)^4 + 1,87 \right]$	$T = \lambda + \frac{14}{15\lambda} + \frac{1}{3}$

<p>3</p>	$1 \geq \psi \geq 0$	$\alpha > 0$	$k = \frac{4 \left(0,425 + \frac{1}{\alpha^2} \right)}{3\psi + 1}$	$\kappa_x = 1$ for $\lambda \leq 0,7$ $\kappa_x = \frac{1}{\lambda^2 + 0,51}$ for $\lambda > 0,7$
	$0 > \psi \geq -1$		$K = 4 \left(0,425 + \frac{1}{\alpha^2} \right) (1 + \psi) - 5\psi(1 - 3,42\psi)$	
<p>4</p>	$1 \geq \psi \geq -1$	$\alpha > 0$	$K = \left(0,425 - \frac{1}{\alpha^2} \right) \frac{3 - \psi}{2}$	$\kappa_\tau = 1$ for $\lambda \leq 0,84$ $\kappa_\tau = \frac{0,84}{\lambda}$ for $\lambda > 0,84$
<p>5</p>	<p>—</p>	$\alpha \geq 1$	$K_\tau = \left(5,34 + \frac{4}{\alpha^2} \right)$	
		$0 < \alpha < 1$	$K_\tau = \left(4 + \frac{5,34}{\alpha^2} \right)$	
<p>Explanations for boundary conditions</p>				

2.12 Webs and flanges of primary supporting members

2.12.1 For non-stiffened webs and flanges of primary supporting members, sufficient buckling strength, as for the hatch cover top and lower plating, is to be demonstrated according to Pt 3, Ch 11, 2.11 Buckling strength of hatch cover structures 2.11.2.

2.13 Longitudinal and transverse secondary stiffeners

2.13.1 It is to be demonstrated that the continuous longitudinal and transverse stiffeners of partial and total plate fields comply with the conditions set out in Pt 3, Ch 11, 2.15 Lateral buckling of secondary stiffeners and Pt 3, Ch 11, 2.16 Torsional buckling of secondary stiffeners.

2.14 Effective width of top and lower hatch cover plating

2.14.1 For demonstration of buckling strength according to Pt 3, Ch 11, 2.15 Lateral buckling of secondary stiffeners and Pt 3, Ch 11, 2.16 Torsional buckling of secondary stiffeners, the effective width of plating may be determined by the following formulae:

$$b_m = \kappa_x b \text{ for longitudinal stiffeners}$$

$$a_m = \kappa_y a \text{ for transverse stiffeners}$$

see also Figure 11.2.4 General arrangement of panel.

The effective width of plating is not to be taken greater than the value obtained from Pt 3, Ch 11, 2.10 Strength calculations 2.10.2.

The effective width e'_m of stiffened flange plates of primary supporting members may be determined as follows:

(a) Stiffening parallel to web of primary supporting member:

$$b < e_m$$

$$e'_m = n b_m$$

n = integer number of stiffener spacings b inside the effective breadth e_m according to Pt 3, Ch 11, 2.10 Strength calculations 2.10.2

$$= \text{int}\left(\frac{e_m}{b}\right)$$

(b) Stiffening perpendicular to web of primary supporting member:

$$a \geq e_m$$

$$e'_m = n a_m < e_m$$

$$n = 2,7 \frac{e_m}{a} \leq l$$

e = width of plating supported according to Pt 3, Ch 11, 2.10 Strength calculations 2.10.2

For $b \geq e_m$ or $a < e_m$, respectively, b and a are to be exchanged.

a_m and b_m for flange plates are in general to be determined for $\psi = 1$.

Scantlings of plates and stiffeners are in general to be determined according to the maximum stresses $\sigma_x(y)$ at webs of primary supporting member and stiffeners, respectively. For stiffeners with spacing b under compression arranged parallel to primary supporting members, no value less than $0,25\sigma_0$ shall be inserted for $\sigma_x(y=b)$.

The stress distribution between two primary supporting members can be obtained by the following formula:

$$\sigma_x(y) = \sigma_{x1} \left\{ 1 - \frac{y}{e} \left[3 + c_1 - 4c_2 - 2\frac{y}{e} (1 + c_1 - 2c_2) \right] \right\}$$

where

$$c_1 = \frac{\sigma_{x2}}{\sigma_{x1}} \quad 0 \leq c_1 \leq 1$$

$$c_2 = \frac{1,5}{e} (e_{m1} + e_{m2}) - 0,5$$

e_{m1} = proportionate effective breadth e_{m1} or proportionate effective width e_{m1} of primary supporting member 1 within the distance e , as appropriate

e_{m2} = proportionate effective breadth e_{m2} or proportionate effective width e_{m2} of primary supporting member 2 within the distance e , as appropriate

σ_{x1}, σ_{x2} = normal stresses in flange plates of adjacent primary supporting member 1 and 2 with spacing e , based on cross-sectional properties considering the effective breadth or effective width, as appropriate

y = distance of considered location from primary supporting member 1

Shear stress distribution in the flange plates may be assumed linearly.

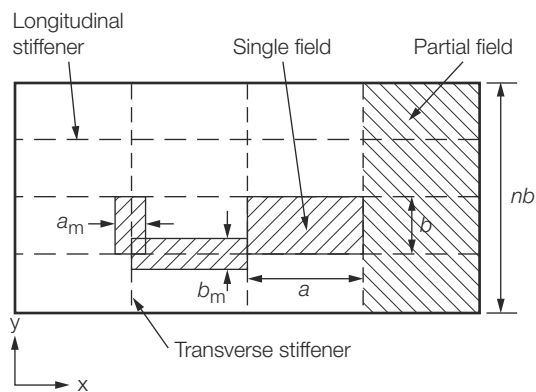

Longitudinal : stiffener in the direction of the length a
 Transverse : stiffener in the direction of the length b

Figure 11.2.4 General arrangement of panel

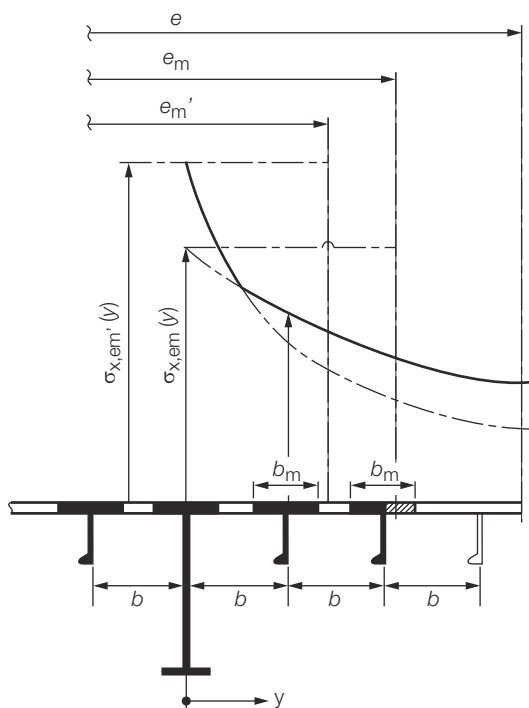

Figure 11.2.5 Stiffening parallel to web of primary supporting member

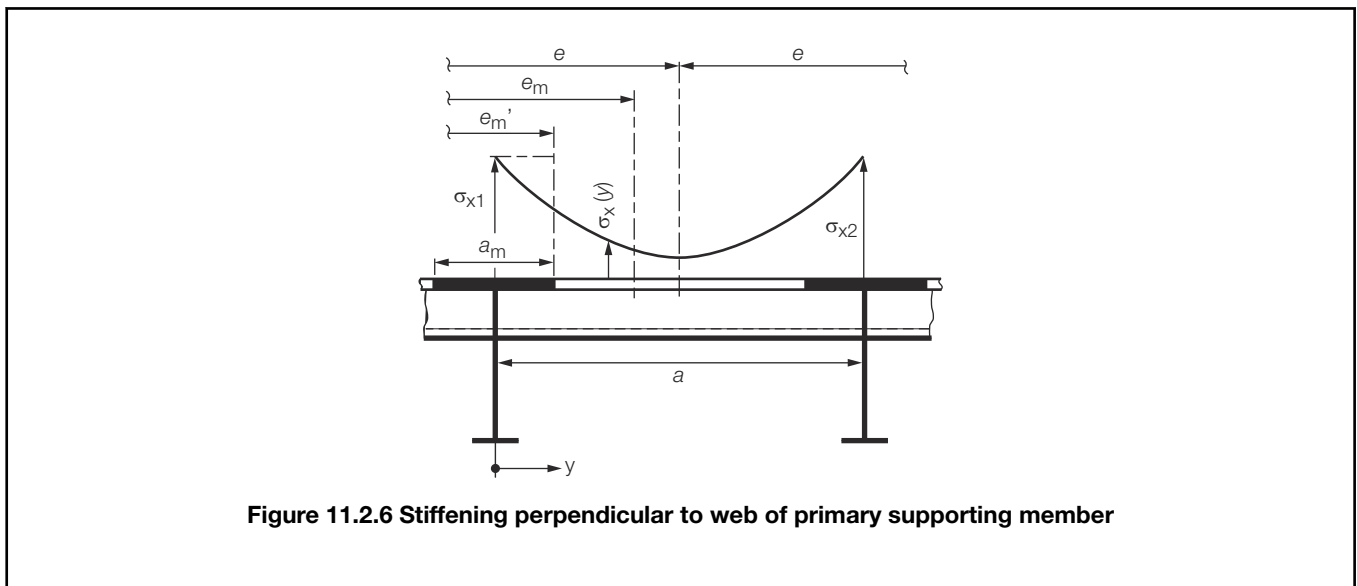

Figure 11.2.6 Stiffening perpendicular to web of primary supporting member

2.15 Lateral buckling of secondary stiffeners

2.15.1 The secondary stiffeners are to comply with the following criteria:

$$\frac{\sigma_a + \sigma_b}{\sigma_0} S \leq 1$$

where

σ_a = uniformly distributed compressive stress, in N/mm², in the direction of the stiffener axis

σ_a = σ_x for longitudinal stiffeners

σ_a = σ_y for transverse stiffeners

σ_b = bending stress, in N/mm², in the stiffener

$$= \frac{M_0 + M_1}{Z_{st} \times 10^3}$$

M_0 = bending moment, in Nmm, due to the deformation w of stiffener, taken equal to:

$$M_0 = \frac{F_{Ki} p_z w}{c_f - p_z} \text{ with } (c_f - p_z) > 0$$

M_1 = bending moment, in Nmm, due to the lateral load p equal to:

$$M_1 = \frac{p b a^2}{24 \times 10^3} \text{ for longitudinal stiffeners}$$

$$M_1 = \frac{p a (n b)^2}{8 c_s \times 10^3} \text{ for transverse stiffeners}$$

n is to be taken equal to 1 for ordinary transverse stiffeners

p = lateral load, in kN/m²

F_{Ki} = ideal buckling force, in N, of the stiffener

$$F_{Kix} = \frac{\pi^2 EI_x}{a^2} \times 10^4 \text{ for longitudinal stiffeners}$$

$$F_{Ky} = \frac{\pi^2}{(nb)^2} EI_y \times 10^4 \text{ for transverse stiffeners}$$

I_x, I_y = net moments of inertia, in cm^4 , of the longitudinal or transverse stiffener, including effective width of attached plating according to Pt 3, Ch 11, 2.14 Effective width of top and lower hatch cover plating 2.14.1. I_x and I_y are to comply with the following criteria:

$$I_x \geq \frac{b t^3}{12 \times 10^4}$$

$$I_y \geq \frac{a t^3}{12 \times 10^4}$$

p_z = nominal lateral load, in N/mm^2 , of the stiffener due to σ_x, σ_y and τ

$$p_{zx} = \frac{t}{b} \left(\sigma_{xl} \left(\frac{\pi b}{a} \right)^2 + 2c_y \sigma_y + \sqrt{2} \tau_1 \right) \text{ for longitudinal stiffeners}$$

$$p_{zy} = \frac{t}{a} \left(2c_x \sigma_{xl} + \sigma_y \left(\frac{\pi a}{nb} \right)^2 \left(1 + \frac{A_y}{at} \right) + \sqrt{2} \tau_1 \right) \text{ for transverse stiffeners}$$

$$\sigma_{xl} = \sigma_x \left(1 + \frac{A_x}{bt} \right)$$

c_x, c_y = factor taking into account the stresses perpendicular to the stiffener's axis and distributed variably along the stiffener's length

$$= 0,5 (1 + \psi) \text{ for } 0 \leq \psi \leq 1$$

$$= \frac{0,5}{1 - \psi} \text{ for } \psi < 0$$

A_x, A_y = net sectional area, in mm^2 , of the longitudinal or transverse stiffener, respectively, without attached plating

$$\tau_1 = \left[\tau - t \sqrt{\sigma_o E \left(\frac{m_1}{a^2} + \frac{m_2}{b^2} \right)} \right] \geq 0$$

for longitudinal stiffeners:

$$\frac{a}{b} \geq 2,0 \quad : m_1 = 1,47 \quad m_2 = 0,49$$

$$\frac{a}{b} < 2,0 \quad : m_1 = 1,96 \quad m_2 = 0,37$$

for transverse stiffeners:

$$\frac{a}{nb} \geq 0,5 \quad : m_1 = 0,37 \quad m_2 = \frac{1,96}{n^2}$$

$$\frac{a}{nb} < 0,5 \quad : m_1 = 0,49 \quad m_2 = \frac{1,47}{n^2}$$

$$w = w_0 + w_1$$

w_0 = assumed imperfection, in mm

$$w_{0x} \leq \min \left(\frac{a}{250}, \frac{b}{250}, 10 \right)$$

$$w_{0y} \leq \min \left(\frac{a}{250}, \frac{nb}{250}, 10 \right)$$

NOTE

For stiffeners sniped at both ends, w_0 must not be taken less than the distance from the mid point of plating to the neutral axis of the profile, including effective width of plating.

w_1 = deformation of stiffener, in mm, at midpoint of stiffener span due to lateral load p

In the case of uniformly distributed load, the following values for w_1 may be used:

$$w_1 = \frac{p b a^4}{384 \times 10^7 E I_x} \text{ for longitudinal stiffeners}$$

$$w_1 = \frac{5a p (n b)^4}{384 \times 10^7 E I_y c_s^2} \text{ for transverse stiffeners}$$

c_f = elastic support provided by the stiffener, in N/mm²

(a) For longitudinal stiffeners:

$$c_{fx} = F_{Kix} \frac{\pi^2}{a^2} (1 + c_{px})$$

$$c_{px} = \frac{1}{1 + \frac{0,91 \left(\frac{12 \times 10^4 I_x}{t^3 b} - 1 \right)}{c_{xa}}}$$

$$c_{xa} = \left(\frac{a}{2b} + \frac{2b}{a} \right)^2 \text{ for } a \geq 2b$$

$$c_{xa} = \left(1 + \left(\frac{a}{2b} \right)^2 \right)^2 \text{ for } a < 2b$$

(b) For transverse stiffeners:

$$c_{fy} = c_s F_{Kiy} \frac{\pi^2}{(n b)^2} (1 + c_{py})$$

$$c_{py} = \frac{1}{1 + \frac{0,91 \left(\frac{12 \times 10^4 I_y}{t^3 a} - 1 \right)}{c_{ya}}}$$

$$c_{ya} = \left(\frac{n b}{2a} + \frac{2a}{n b} \right)^2 \text{ for } n b \geq 2a$$

$$c_{ya} = \left(1 + \left(\frac{n b}{2a} \right)^2 \right)^2 \text{ for } n b < 2a$$

c_s = factor accounting for the boundary conditions of the transverse stiffener

= 1,0 for simply supported stiffeners

= 2,0 for partially constrained stiffeners

Z_{st} = net section modulus of stiffener (longitudinal or transverse), in cm³, including effective width of plating according to Pt 3, Ch 11, 2.14 Effective width of top and lower hatch cover plating 2.14.1.

If no lateral load p is acting, the bending stress σ_b is to be calculated at the mid point of the stiffener span for that fibre which results in the largest stress value. If a lateral load p is acting, the stress calculation is to be carried out for both fibres of the stiffener's cross-sectional area (if necessary for the biaxial stress field at the plating side).

2.16 Torsional buckling of secondary stiffeners

2.16.1 The longitudinal secondary stiffeners are to comply with the following criteria:

$$\frac{\sigma_{X^S}}{\kappa_T \sigma_o} \leq 1,0$$

where

κ_T = coefficient taken equal to:

$$\kappa_T = 1,0 \text{ for } \lambda_T \leq 0,2$$

$$\kappa_T = \frac{1}{\varphi + \sqrt{\varphi^2 - \lambda_T^2}} \text{ for } \lambda_T > 0,2$$

$$\Phi = 0,5 (1 + 0,21 (\lambda_T - 0,2) + \lambda_T^2)$$

λ_T = reference degree of slenderness taken equal to:

$$\lambda_T = \sqrt{\frac{\sigma_F}{\sigma_{KiT}}}$$

$$\sigma_{KiT} = \frac{E}{I_p} \left(\frac{\pi^2 I_\omega 10^2}{a^2} \varepsilon + 0,385 I_T \right), \text{ in N/mm}^2$$

For I_p , I_T , I_ω , see Figure 11.2.7 Dimensions of stiffener and Table 11.2.7 Moments of inertia

I_p = net polar moment of inertia of the stiffener, in cm^4 , related to the point C

I_T = net St.Venant's moment of inertia of the stiffener, in cm^4

I_ω = net sectorial moment of inertia of the stiffener, in cm^6 , related to the point C

ε = degree of fixation taken equal to:

$$\varepsilon = 1 + 10^{-3} \sqrt{\frac{a^4}{\frac{3}{4} \pi^4 I_\omega \left(\frac{b}{t^3} + \frac{4h_w}{3t \cdot 3w} \right)}}$$

h_w = web height, in mm

t_w = net web thickness, in mm

b_f = flange breadth, in mm

t_f = net flange thickness, in mm

A_w = net web area equal to: $A_w = h_w t_w$

A_f = net flange area equal to: $A_f = b_f t_f$

$e_f = h_w + \frac{t_f}{2}$, in mm

b = stiffener spacing, in mm

t = local net plate thickness of the attached plate, in mm.

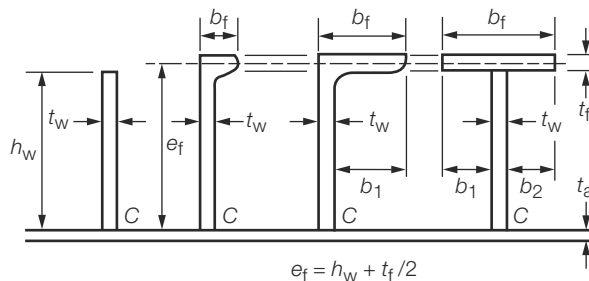

Figure 11.2.7 Dimensions of stiffener

Table 11.2.7 Moments of inertia

Section	I_P	I_T	I_ω
Flat bar	$\frac{h_w^3 t_w}{3 \times 10^4}$	$\frac{h_w t_w^3}{3 \times 10^4} - \left(1 - 0,63 \frac{t_w}{h_w}\right)$	$\frac{h_w^3 t_w^3}{36 \times 10^6}$
Sections with bulb or flange	$\left(\frac{A_w h_w^2}{3} + A_f e_f^2\right) 10^{-4}$	$\frac{h_w t_w^3}{3 \times 10^4} \left(1 - 0,63 \frac{t_w}{h_w}\right) + \frac{b_f t_f^3}{3 \times 10^4} \left(1 - 0,63 \frac{t_f}{b_f}\right)$	for bulb and angle sections: $\frac{A_f^2 e_f^2 b_f^2}{12 \times 10^6} \left(\frac{A_f + 2,6 A_w}{A_f + A_w}\right)$ for tee sections: $\frac{b_f^3 t_f^2 e_f^2}{12 \times 10^6}$

2.16.2 For transverse secondary stiffeners loaded by compressive stresses and which are not supported by longitudinal stiffeners, sufficient torsional buckling strength is to be demonstrated analogously in accordance with this sub-Section.

2.17 Pontoon covers

2.17.1 The structural assessment of pontoon covers, as defined in Pt 3, Ch 11, 1.1 Application 1.1.5, is to be carried out by direct calculations, which are to be submitted for approval, using the minimum design pressures acting on the hatch covers defined in Table 11.2.8 Pontoon cover minimum design pressures. The permissible stress, deflection and buckling criteria are given in Table 11.2.10 Steel pontoon cover permissible stress, deflection and buckling criteria.

Table 11.2.8 Pontoon cover minimum design pressures

For ships of 100 m in length and above:	
(a)	<p>Position 1 hatch covers located in the forward quarter of the ship's length shall be designed for wave pressures at the forward perpendicular, calculated from the following equation:</p> <p>Minimum design pressure, $p = 49,05 + 9,81 (L_H - 100)a$ in kN/m^2 where</p> <p>L_H is L for ships of not more than 340 m but not less than 100 m in length and equal to 340 m for ships of more than 340 m in length:</p> <p style="margin-left: 40px;">$a = 0,0074$ for Type B freeboard ships $= 0,0363$ Ships assigned reduced freeboard</p> <p>The pressure, p, is to be reduced linearly to $34,3 \text{ kN/m}^2$ at the end of the forward quarter's length, as shown in <i>Table 11.2.9 Summary of pontoon cover minimum design pressures</i></p> <p>The design pressure used for each hatch cover panel shall be that determined at its mid point location:</p>
(b)	All other position 1 hatch covers shall be designed to $34,3 \text{ kN/m}^2$
(c)	Position 2 hatch covers shall be designed to $25,5 \text{ kN/m}^2$
(d)	Where a position 1 hatchway is located at least one superstructure standard height higher than the freeboard deck, it may be designed to $34,3 \text{ kN/m}^2$
For ships 24 m in length:	
(a)	<p>Position 1 hatch covers located in the forward quarter of the ship's length shall be designed for wave pressures of $23,8 \text{ kN/m}^2$ at the forward perpendicular and reduced linearly to $19,6 \text{ kN/m}^2$ at the end of the forward quarter's length, as shown in <i>Table 11.2.9 Summary of pontoon cover minimum design pressures</i>.</p> <p>The design pressure used for each hatch cover panel shall be that determined at its mid point location</p>
(b)	All other position 1 hatch covers shall be designed to $19,6 \text{ kN/m}^2$
(c)	Position 2 hatch covers shall be designed to $14,7 \text{ kN/m}^2$
(d)	Where a position 1 hatchway is located at least one superstructure standard height higher than the freeboard deck, it may be designed to $19,6 \text{ t/m}^2$
For ships between 24 m and 100 m in length, and for positions between FP and $0,25L$, wave pressures shall be obtained by linear interpolation of the values shown in <i>Table 11.2.9 Summary of pontoon cover minimum design pressures</i>	

Table 11.2.9 Summary of pontoon cover minimum design pressures

Deck location	Longitudinal position		
	FP	$0,25L$	Aft of $0,25L$
$L > 100 \text{ m}$			
Freeboard deck	Equation given in <i>Table 11.2.8 Pontoon cover minimum design pressures</i>	$34,3 \text{ kN/m}^2$	$34,3 \text{ kN/m}^2$
Superstructure deck	$34,3 \text{ kN/m}^2$		$25,5 \text{ kN/m}^2$
$L = 100 \text{ m}$			
Freeboard deck	$49,05 \text{ kN/m}^2$	$34,3 \text{ kN/m}^2$	$34,3 \text{ kN/m}^2$
Superstructure deck	$34,3 \text{ kN/m}^2$		$25,5 \text{ kN/m}^2$
$L = 24 \text{ m}$			
Freeboard deck	$23,84 \text{ kN/m}^2$	$19,6 \text{ kN/m}^2$	$19,6 \text{ kN/m}^2$
Superstructure deck	$19,6 \text{ kN/m}^2$		$14,7 \text{ kN/m}^2$

Table 11.2.10 Steel pontoon cover permissible stress, deflection and buckling criteria

Location	Permissible bending stress, N/mm ²	Permissible shear stress, N/mm ²	Permissible deflection metres
Weather deck – Positions 1 and 2	0,68 σ_o	0,39 σ_o	0,0044 l_o
Buckling requirements			
Symbols			
<p>b = length of panel (longer panel dimension), in mm, in transverse direction, see Figure 11.2.8 Cover with stiffening fitted normal to the axis of primary bending</p> <p>s = spacing of webs and stiffeners (shorter panel dimension), in mm</p> <p>t = thickness of plating, in mm</p> <p>σ_{ac} = corrected critical buckling stress, in N/mm²</p> <p>σ_b = the compressive bending stress, in N/mm², in the steel cover plating, calculated by taking the cover as a loaded beam simply supported at its ends</p> <p>σ_c = critical buckling stress of panel, in N/mm²</p> <p>σ_o = yield stress of cover plating material, in N/mm²</p> <p>$\sigma_c = 18,6R_c \left(\frac{t}{b}\right)^2 \times 10^4 \text{ N/mm}^2$</p> <p>$\sigma_{ac} = \sigma_o \left(1 - \frac{\sigma_o}{4\sigma_c}\right) \text{ N/mm}^2$</p> <p>(a) Where primary bending stress acts on longer panel edge b, see Figure 11.2.8 Cover with stiffening fitted normal to the axis of primary bending:</p> $\frac{\sigma_c}{\sigma_b} \left(\text{or } \frac{\sigma_{ac}}{\sigma_b}\right) \geq 1,3 \quad \text{where } R_c = \left(\frac{s}{b} + \frac{b}{s}\right)^2$ <p>Where primary bending stress acts on shorter panel edge s:</p> $\frac{\sigma_c}{\sigma_b} \left(\text{or } \frac{\sigma_{ac}}{\sigma_b}\right) \geq 1,2 \quad \text{where } R_c = 4 \left(\frac{b^2}{s^2}\right)$ <p>If $\sigma_c > 0,5 \sigma_o$, then corrected value σ_{ac} is used</p> <p>It is recommended that $\frac{b}{s} < 5,0$</p> <p>(b) Where covers are stiffened in two directions by a grillage formation, buckling checks are to be carried out as per (a) above for bending stresses acting on both the longer and shorter edges of the panel</p> <p>For the derivation of the section modulus for primary members, an effective width of plating to achieve a balanced section is to be adopted</p> <p>However, a greater width of plating in accordance with Pt 3, Ch 3, 3.2 Geometric properties of section may be adopted where this is suitably stiffened in the directions being considered from the buckling aspect</p>			

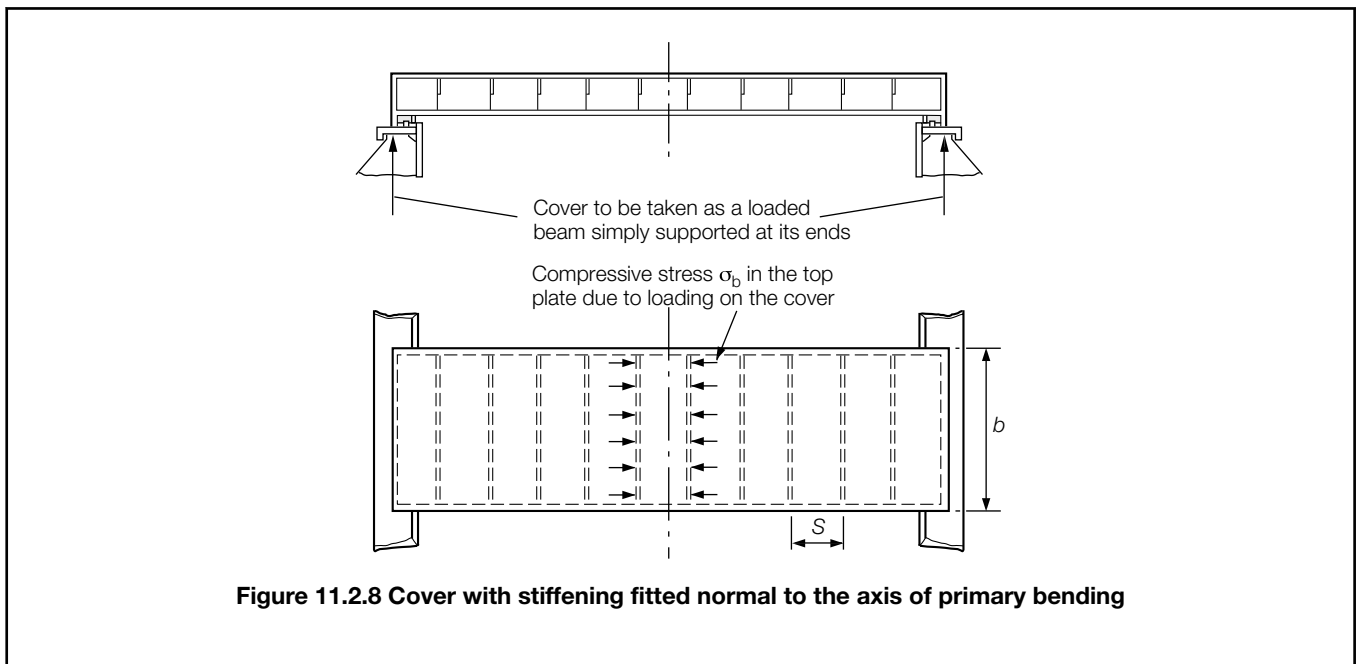

Figure 11.2.8 Cover with stiffening fitted normal to the axis of primary bending

2.17.2 The gross thickness of the plating of steel pontoon covers is to be not less than the greater of:

- (a) $t = 0,01s$ mm
- (b) $t = 6,0$ mm as required by *Table 11.2.8 Pontoon cover minimum design pressures*

where

s = stiffener spacing in mm

t = thickness as required by *Pt 3, Ch 11, 2.17 Pontoon covers 2.17.1*.

2.17.3 The gross scantlings of steel pontoon cover primary and secondary webs or stiffeners are to be not less than would be required to satisfy the requirements of *Table 11.2.11 Steel pontoon cover webs and stiffeners*. Alternatively, scantlings may be determined by direct calculations, which are to be submitted for approval. In no case are the stresses and deflections given in *Table 11.2.10 Steel pontoon cover permissible stress, deflection and buckling criteria* to be exceeded.

Table 11.2.11 Steel pontoon cover webs and stiffeners

Symbols	Primary and secondary stiffening requirements
<p>A_s = shear area, in cm²</p> <p>K = higher tensile steel factor, see Pt 3, Ch 2, 1.2 Steel</p> <p>K_1 = 1281</p> <p>C_1 = 696</p> <p>I_0 = moment of inertia at mid-span, in cm⁴</p> <p>I_1 = moment of inertia at supports, in cm⁴</p> <p>where</p> <p>$I_1 > 0,05 I_0$</p> <p>l_0 = unsupported span, in metres, measured as shown in Figure 11.2.9 Diagrammatic profile of web or stiffener or portable beam</p> <p>l_1 = proportion of the span, in metres, measured as shown in Figure 11.2.9 Diagrammatic profile of web or stiffener or portable beam. The depth and face area over the remainder of the span is assumed to be constant</p> <p>p = minimum design pressure, in kN/m², acting on the hatch covers as defined in Table 11.2.8 Pontoon cover minimum design pressures</p> <p>Z_0 = section modulus at mid-span, in cm³</p> <p>Z_1 = section modulus at supports, in cm³</p> $C_H = \frac{8 \alpha_H^3 (1 - \beta_H)}{1 + \frac{0,2 + 3\sqrt{\beta_H}}{\alpha_H}}$ $K_H = \frac{3,2 \alpha_H - \gamma_H - 0,8}{1 + \frac{7,0 \gamma_H + 0,4}{\alpha_H}}$ <p>but not less than 1,0. To be specially considered when discontinuities in area of face material occur</p> $\alpha_H = \frac{l_1}{l_0} \quad \beta_H = \frac{I_1}{I_0} \quad \gamma_H = \frac{Z_1}{Z_0}$	$Z_0 = \frac{psl_0^2 K_H k}{K_1} \text{ cm}^3$ $I_0 = \frac{psl_0^3 C_H}{C_1} \text{ cm}^4$ $A_s = \frac{0,01282psl_0}{\sigma_o} \text{ cm}^2$ <p>Note Where the ends of the secondary panel stiffeners are effectively bracketed or continuous, the values of modulus and inertia of the secondary panel stiffeners may be reduced respectively by 33% and 80%.</p>

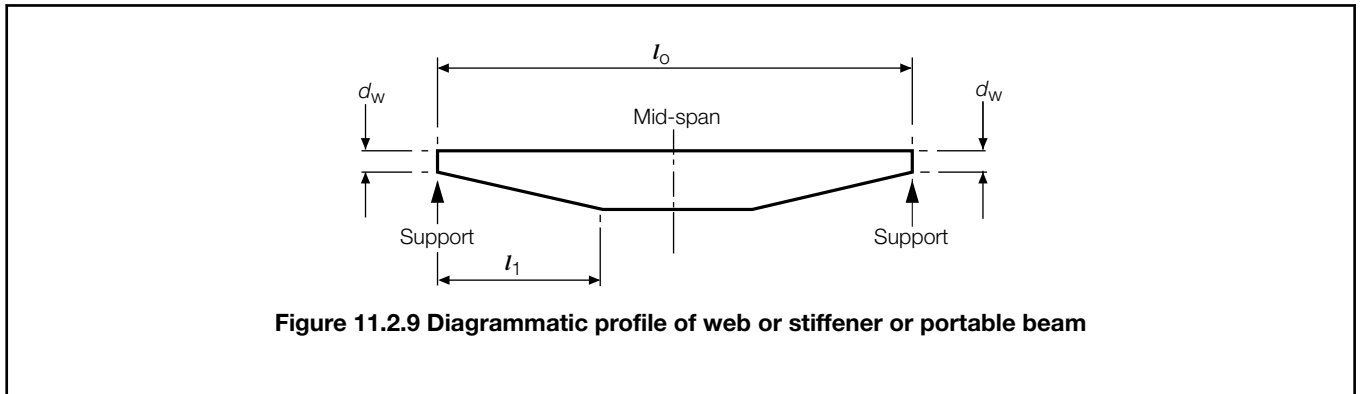

■ Section 3 Hatch beams and wood covers

3.1 Portable hatch beams

3.1.1 The section modulus and moment of inertia of portable web plate beams stiffened at their upper and lower edges by continuous flat bars are to satisfy the requirements of *Pt 3, Ch 11, 2.17 Pontoon covers* for pontoon covers. Alternatively, direct calculations may be used, provided the requirements of *Pt 3, Ch 11, 2.17 Pontoon covers* for pontoon covers are complied with.

3.1.2 The ends of web plates are to be doubled, or inserts fitted for at least 180 mm along length of web.

3.1.3 At beams which carry the ends of wood or steel hatch covers, a vertical 50 mm flat is to be arranged on the upper face plate. The width of bearing surface for hatch covers is to be not less than 65 mm.

3.1.4 Carriers or sockets, or other suitable arrangements, of suitable construction are to provide means for the efficient fitting and securing of portable hatch beams. The width of bearing surface is to be not less than 75 mm.

3.1.5 Sliding hatch beams are to be provided with an efficient device for locking them in their correct fore and aft positions when the hatchway is closed.

3.2 Wood covers

3.2.1 Wood covers are to have a finished thickness of not less than 60 mm in association with an unsupported span of not more than 1,5 m. Where the 'tween deck height measured vertically on the centreline of the ship from 'tween deck to underside of the hatch cover stiffeners on deck above, exceeds 2,6 m, the thickness of the wood covers is to be increased at the rate of 16,5 per cent per metre excess in 'tween deck height.

3.2.2 The ends of all wood hatch covers are to be protected by encircling galvanised steel bands, about 65 mm wide and 33 mm thick, efficiently secured.

■ Section 4 Hatch cover securing arrangements and tarpaulins

4.1 Cargo oil tank and adjacent spaces

4.1.1 For access hatchways to cargo oil tanks and adjacent spaces, see *Pt 3, Ch 11, 7 Tanker access arrangements and closing appliances*.

4.2 Steel covers – Clamped and gasketed

4.2.1 These requirements, unless stated otherwise, apply to steel hatch covers in Positions 1 and 2 fitted with gaskets and securing devices and situated above dry cargo holds.

4.2.2 Where steel hatch covers are fitted to hatch openings on weather decks, the arrangements are to be such that weathertightness can be maintained. A sufficient number of securing devices is to be provided at each side of the hatch cover, considering the requirements of *Pt 3, Ch 11, 2.9 Net scantling of primary supporting members 2.9.4*. This applies also to hatch covers consisting of several parts.

4.2.3 The weight of the covers and weather loading may be transmitted to the ship's structure by means of continuous steel to steel contact of the cover skirt plate with the ship's structure in association with a maximum bearing pressure of 200 kgf/cm². Alternatively the weight may be transmitted by means of defined bearing pads. For covers loaded by containers or other cargo, the total load together with inertial forces generated by the ship's motion, are to be transmitted by means of defined bearing pads only.

4.2.4 For the design of the securing devices against shifting, the horizontal mass forces $F_n = m a$ are to be calculated with the following accelerations:

$$a_x = 0,2 g \text{ in longitudinal direction}$$

$$a_y = 0,5 g \text{ in transverse direction}$$

$$m = \text{sum of mass of cargo lashed on the hatch cover and mass of hatch cover.}$$

4.2.5 For the transmission of the support forces resulting from the load cases specified in *Pt 3, Ch 11, 2.3 Load model* and of the horizontal mass forces specified in *Pt 3, Ch 11, 4.2 Steel covers – Clamped and gasketed 4.2.4*, hatch cover supports are to be provided, which are to be designed such that the nominal surface pressures do not, in general, exceed the following values:

$$p_{n \max} = d p_n, \text{ in N/mm}^2$$

$$d = 3,75 - 0,015L$$

$$d_{\max} = 3,0$$

$$d_{\min} = 1,0 \text{ in general}$$

$$= 2,0 \text{ for partial loading conditions, see } Pt 4, Ch 8, 11.2 \text{ Direct calculations } 11.2.4$$

$$p_n = \text{see Table 11.4.1 Permissible nominal surface pressure } p_n$$

For metallic supporting surfaces not subjected to relative displacements, the nominal surface pressure applies:

$$p_{n \max} = 3 p_n, \text{ in N/mm}^2$$

The supports are to be designed such that the permissible stresses according to *Pt 3, Ch 11, 2.4 Allowable stress and deflection 2.4.1* are not exceeded.

Table 11.4.1 Permissible nominal surface pressure p_n

Support material	p_n in N/mm ² when loaded by	
	Vertical force	Horizontal force (on stoppers)
Hull structural steel	25	40
Hardened steel	35	50
Plastics materials on steel	50	—

4.2.6 Drawings of hatch cover supports which specify the permitted maximum pressure related to long-term stress, given by the material manufacturer, must be submitted.

4.2.7 Where large relative displacements of the supporting surfaces of hatch cover supports are to be expected, the use of material having low wear and frictional properties is recommended. If necessary, sufficient abrasive strength may be shown by tests demonstrating an abrasion of support surfaces of not more than 0,3 mm per year in service, at a total distance of shifting of 15 000 m/year.

4.2.8 The substructures of the hatch cover supports must be of such a design that a uniform pressure distribution is achieved. Irrespective of the arrangement of stoppers, the supports must be able to transmit the following force P_h in the longitudinal and transverse direction:

$$P_h = \mu \frac{P_v}{\sqrt{d}}$$

where

P_v = vertical supporting force

μ = frictional coefficient

= 0,5 in general

For non-metallic, low-friction support materials on steel, the friction coefficient may be reduced, but is not to be less than 0,35. The substructures are to be designed such that the permissible stresses according to *Pt 3, Ch 11, 2.4 Allowable stress and deflection 2.4.1* are not exceeded.

4.2.9 For substructures and adjacent structures of supports subjected to horizontal forces P_h , as defined in *Pt 3, Ch 11, 4.2 Steel covers – Clamped and gasketed 4.2.8*, a fatigue strength analysis is to be carried out.

4.2.10 Hatch covers are to be sufficiently secured against horizontal shifting. Stoppers are to be provided for hatch covers on which cargo is carried. The greater of the loads resulting from *Pt 3, Ch 11, 2.3 Load model 2.3.3* and *Pt 3, Ch 11, 4.2 Steel covers – Clamped and gasketed 4.2.4* is to be applied for the dimensioning of the stoppers and their substructures. The permissible stress in stoppers and their substructures in the cover and in the coamings is to be determined according to *Pt 3, Ch 11, 2.4 Allowable stress and deflection 2.4.1*. In addition, the provisions in *Pt 3, Ch 11, 4.2 Steel covers – Clamped and gasketed 4.2.5* are to be observed.

4.2.11 The sealing is to be obtained by a continuous gasket of relatively soft elastic material compressed to achieve the necessary weathertightness. Similar sealing is to be arranged between cross-joint elements. Where fitted, compression flat bars or angles are to be well rounded where in contact with the gasket and are to be made of a corrosion-restraint material or suitably protected against corrosion.

4.2.12 Special consideration is to be given to the gasket and securing arrangements in ships with large relative movements between cover and ship structure or between cover elements. The relative horizontal and vertical deflections are to be calculated and submitted with the hatch cover plans. Where applicable, deflections due to thermal effects and internal pressure loads are also to be included.

4.2.13 The suitability of the gasket material and the securing adhesive is the responsibility of the Builder and Owner. When selecting such material, consideration is to be given to its suitability for the environmental conditions likely to be experienced by the ship and its compatibility with the cargo carried. The material and form of gasket selected is to be considered in conjunction with the type of cover, the securing arrangement and the expected relative movement between cover and ship structure. The gasket is to be effectively secured to the cover.

4.2.14 Drainage is to be arranged inside the line of gasket by means of a gutter bar or vertical extension of the hatch side and end coaming; drain openings are to be provided at appropriate positions on the drain channels. This requirement need not be complied with for special ships carrying container cargoes when the requirements of *Pt 4, Ch 8, 11 Hatch covers* are satisfied.

4.2.15 Where the arrangement includes continuous steel to steel contact between hatch cover and coaming or between hatch cover and ship structure or at cross-joints, drainage on both sides of the gasket is to be provided.

4.2.16 Drain openings are to be arranged at the ends of drain channels and are to be provided with non-return valves for preventing ingress of water from outside.

The following requirements are to be complied with:

- (a) If manufactured from steel, the minimum drain pipe wall thickness is to be not less than 4,5 mm.
- (b) If not manufactured from steel, details of the drain, including the material specification, method of manufacture and details of any tests carried out, are to be submitted for consideration.
- (c) The drains are to be securely attached to the hatch coaming and adequately protected if in an exposed position.
- (d) When the drain is fitted to a hold also designed to carry liquids, a shut-off valve is to be incorporated into the assembly.
- (e) Drain openings in hatch coamings are to be arranged with sufficient distance to areas of stress concentration (e.g. hatch corners, transitions to crane posts).

4.2.17 Panel hatch covers are to be secured by appropriate devices (bolts, wedges or similar) suitably spaced alongside the coamings. The securing devices are not to have a vertical clearance but are to be pre-tensioned when the cover is in the closed position. The devices are also to be arranged in close proximity horizontally to the gasket. Arrangement and spacing are to be determined with due attention to the effectiveness for weathertightness, depending upon the type and the size of the hatch cover, as well as on the stiffness of the cover edges between the securing devices. A minimum of two securing devices for each side of a panel are to be fitted. The securing devices should be arranged as close to the panel corners as is practicable.

4.2.18 Between cover and coaming and at cross-joints, a gasket pressure sufficient to obtain weathertightness is to be maintained by the securing devices. This pressure is to be specified. Securing devices of a design other than rod or bolts will be specially considered, see Pt 3, Ch 11, 4.2 Steel covers – Clamped and gasketed 4.2.26.

4.2.19 The net sectional area of each securing device is to be not less than:

$$A = \frac{1,4S_1W_1}{50f} \text{cm}^2 \quad \left(\frac{1,4S_1W_1}{5,1f} \text{cm}^2 \right)$$

where

$$f = \left(\frac{\sigma_c}{235} \right)^e$$

S_1 = spacing between securing devices, in metres, not to exceed 6 m and not to be taken less than 2 m

W_1 = the gasket loading per unit length, in N/cm (kgf/cm), but not less than 50 N/cm (5,1 kgf/cm)

σ_c = specified minimum upper yield stress in N/mm² (kgf/mm²) of the steel used for cleats or securing devices, to be taken not greater than 70 per cent of the ultimate tensile strength

e = 0,75 for $\sigma_c \geq 235$ (24)

= 1,0 for $\sigma_c < 235$ (24).

4.2.20 Rods or bolts are to have a gross diameter not less than 19 mm for hatchways exceeding 5 m² in area.

4.2.21 In order to ensure compression between gasket and compression bar along the full length, the cover edge stiffness is to be examined. The inertia of the cover edge is to be not less than:

$$I_E = 0,6W_1 S_1^4 \text{cm}^4$$

$$(I_E = 5,89W_1 S_1^4 \text{cm}^4)$$

where W_1 and S_1 are as defined in Pt 3, Ch 11, 4.2 Steel covers – Clamped and gasketed 4.2.12.

4.2.22 Securing devices are to be constructed of reliable design and securely attached to the hatchway coamings, decks or covers. Individual securing devices on each cover are to have approximately the same stiffness characteristics.

4.2.23 Where rod cleats are fitted, resilient washers or cushions are to be incorporated.

4.2.24 Where hydraulic cleating is adopted, a positive means is to be provided to ensure that it remains mechanically locked in the closed position in the event of failure of the hydraulic system.

4.2.25 The cross-joints of multi-panel covers are to be arranged with wedges, or locators (male and female) to retain the hatch covers in the correct sealing position, the number and spacing is to be arranged to suit the size and type of cover, gasket arrangements and stiffness of cover edges at cross-joints. Means are also to be provided to prevent excessive relative vertical deflections between loaded and unloaded panels. The arrangement of the gasket retaining angle and the compression bar at the cross-joints is to be such that the gasket compression is maintained between loaded and unloaded panels.

4.2.26 In addition to the requirements given above, all hatch covers, especially those carrying deck cargo are to be effectively secured against horizontal shifting due to the horizontal forces arising from the ship motions.

4.2.27 To prevent damage to hatch covers and ship structure, the location of stoppers is to be compatible with the relative movements between hatch covers and ship structure. The number should be as small as practically possible.

4.2.28 Towards the ends of the ship, vertical acceleration forces may exceed gravity forces. The resulting lifting forces must therefore be also considered when dimensioning the securing devices. Also lifting forces from cargo secured on the hatch cover during rolling are to be taken into account.

4.2.29 Hatch coamings and supporting structure are to be adequately stiffened to accommodate the loading from hatch covers and cargo carried thereon.

4.2.30 Upon completion of installation of hatch covers, a hose test with a pressure of water as specified in *Table 1.9.1 Testing requirements* in Chapter 1 is to be carried out. Alternative methods of tightness testing will be considered. This does not apply to covers with reduced securing arrangements as specified in *Pt 4, Ch 8, 11 Hatch covers*.

4.2.31 All hatch covers are to be tested to prove satisfactory operation.

4.2.32 It is recommended that ships with steel hatch covers are supplied with an operation and maintenance manual including:

- (a) opening and closing instructions;
- (b) maintenance requirements and specifications for packings, securing devices and operating items;
- (c) cleaning instructions for the drainage system;
- (d) corrosion prevention instructions;
- (e) list of spare parts.

4.2.33 The spacing and size of securing devices in hatch covers for holds which may be flooded and used for ballast tanks and holds in OBO, ore or oil and similar types of ship are to correspond to the reaction forces at the cover edges found by calculation. The loading is to be as required by *Pt 4, Ch 7, 12.4 Load model 12.4.1*.

The permissible stress in the securing devices is not to exceed the following:

$$\sigma_e = 0,9 \times 235 f \text{ N/mm}^2$$

= where

f = material factor as defined in *Pt 3, Ch 11, 4.2 Steel covers – Clamped and gasketed 4.2.19*

σ = bending stress in N/mm²

σ_e = equivalent stress, in N/mm²

$$= \sqrt{(\sigma^2 + 3 \tau^2)}$$

τ = shear stress in N/mm²

4.2.34 On tank hatch covers in 'tween decks the maximum spacing of cleats is to be 600 mm, but cleats are to be arranged as close to the corners as practicable.

4.2.35 Steel hatch covers with special sealing arrangements, insulated covers, flush hatch covers, and covers having coamings less than required by *Pt 3, Ch 11, 5.1 General*, will be specially considered.

4.2.36 The material and weld specifications of stoppers and securing devices are to be shown in the drawings of the hatch covers.

4.2.37 Securing devices of special design in which significant bending or shear stresses occur may be designed as anti-lifting devices according to *Pt 4, Ch 8, 11.2 Direct calculations 11.2.5*. The packing line pressure, as defined in *Pt 3, Ch 11, 4.2 Steel covers – Clamped and gasketed 4.2.12*, multiplied by the spacing between securing devices, as defined in *Pt 3, Ch 11, 4.2 Steel covers – Clamped and gasketed 4.2.12*, is to be applied as design load.

4.3 Portable covers – Tarpaulins and battening devices

4.3.1 At least two layers of tarpaulin in good condition are to be provided for each hatchway in Positions 1 and 2.

4.3.2 Tarpaulins are to be free from jute, waterproof and of ample strength. The minimum mass of the material before treatment is to be 0,65 kg/m² if the material is to be tarred, 0,60 kg/m² if to be chemically dressed, or 0,55 kg/m² if to be dressed with black oil. A certificate to this effect is to be supplied by the makers of the tarpaulins. Special consideration will be given to the use of synthetic materials for tarpaulins.

4.3.3 Cleats are to be of an approved pattern, at least 65 mm wide, with edges so rounded as to minimise damage to the wedges, and are to be spaced not more than 600 mm from centre to centre: the first and last cleats along each side or end are to be not more than 150 mm from the hatch corners. Cleats should be so set as to fit the taper of the wedges.

4.3.4 Battens and wedges shall be efficient and in good condition. Wedges are to be of tough wood, generally not more than 200 mm in length and 50 mm in width. They should have a taper of not more than 1 in 6 and should not be less than 13 mm at the point.

4.3.5 For all hatchways in Positions 1 and 2, steel bars or other equivalent means are to be provided in order to secure each section of hatch covers efficiently and independently after the tarpaulins are battened down. Hatch covers of more than 1,5 m in length are to be secured by at least two such securing appliances. Where hatchway covers extend over intermediate supports, steel bars or their equivalent are to be fitted at each end of each section of covers. At all other hatchways in exposed positions on weather decks, ring bolts or other fittings suitable for lashings are to be provided.

4.4 Packing material

4.4.1 Packing material is to be suitable for all expected service conditions of the ship and is to be compatible with the cargoes to be transported. The packing material is to be selected with regard to dimensions and elasticity in such a way that expected deformations can be carried. Forces are to be carried by the steel structure only.

4.4.2 Packing material is to be compressed so as to give the necessary tightness effect for all expected operating conditions. Special consideration will be given to the packing arrangement in ships with large relative movements between hatch covers and coamings or between hatch cover sections.

■ Section 5 Hatch coamings

5.1 General

5.1.1 The height of coamings above the upper surface of the deck, measured above sheathing if fitted, for hatchways closed by portable covers secured weathertight by tarpaulins and battening devices, is to be not less than:

- 600 mm at Position 1,
- 450 mm at Position 2.

5.1.2 The height of coamings of hatchways situated in Positions 1 and 2 closed by steel covers fitted with gaskets and clamping devices are to be as specified in *Pt 3, Ch 11, 5.1 General 5.1.1*, but may be reduced, or the coamings may be omitted entirely, if the safety of the ship is not thereby impaired in any sea condition. Special attention will be given in such cases to the scantlings of the covers, to their gasketing and securing arrangements and to the drainage of recesses in the deck. The agreement of the National Authority concerned will also be required.

5.1.3 The height of coamings may be required to be increased on ships of Type 'B-100' or Type 'B-60' where this is shown to be necessary by the floatability calculations required by the *International Convention on Load Lines, 1966*.

5.2 Construction

5.2.1 Vertical cargo hatch coamings 600 mm or more in height are to be stiffened on their upper edges by a horizontal bulb flat or equivalent which is to be not less than 180 mm in width for ships where L is greater than 75 m. Additional support is to be afforded by fitting brackets or stays from the bulb flat to the deck at intervals of not more than 3 m. Each bracket or stay is to be aligned with suitable underdeck stiffeners and is to have a softened nose.

5.2.2 Vertical coamings less than 600 mm in height are to be stiffened at their upper edge by a substantial rolled or fabricated section. Additional support is to be arranged as required by *Pt 3, Ch 11, 5.2 Construction 5.2.2*.

5.2.3 Cargo hatchways on other decks, in positions not specified in *Pt 3, Ch 1, 6.5 Position 1 and Position 2*, are to be suitably framed.

5.2.4 The scantlings and arrangements of hatch coamings acting as girders will be specially considered. The coamings are to be arranged with intermediate continuous horizontal stiffeners supported by the bracket stays.

5.2.5 Sloped cargo hatch coamings will be specially considered. In general, the sloped coaming arrangement is to be restricted to the hatch side coamings with vertical coamings at the ends. The sloped coaming is not to have a knuckle and the angle to the vertical is not to exceed 30°. The scantlings are to be in accordance with *Pt 3, Ch 11, 5.2 Construction 5.2.1, Pt 3, Ch 11, 5.2 Construction 5.2.2* and *Pt 3, Ch 11, 5.3 Strength criteria*, except that the end coamings are to be increased by 20 per cent for a distance of $0,15b$ from the side coamings where b is the width of the hatchway at the deck. Particular care is to be taken where the proposed loadings exceed those given in *Pt 3, Ch 11, 2.3 Load model* and *Pt 3, Ch 3, 5 Design loading*, and where the coamings are not in alignment with the topside tank vertical strake in bulk carriers.

5.2.6 A radiused coaming plate at the corner junction of the longitudinal and transverse cargo hatch coamings is acceptable for ships where $L \leq 90$ m and the heights of coamings are not in excess of that specified in Pt 3, Ch 11, 5.1 General 5.1.1. Where $L > 90$ m the corner junctions are to be rectangular and arranged with continuation brackets as required by Pt 3, Ch 11, 5.2 Construction 5.2.8.

5.2.7 The deck plating is to extend inside the coamings and the side coamings are to be extended in the form of tapered brackets. A recommended arrangement is shown in Figure 11.5.1 Coaming continuation bracket - Recommended arrangement. Continuation brackets are also to be arranged athwartships in line with the hatch end coamings and the under deck transverse. In bulk carriers the athwartship brackets, in conjunction with the hatch end beams should be arranged to achieve a satisfactory overlap with the top side tank transverses. In cases where the hatch end beam is formed by the transverse bulkhead top stool the horizontal knuckle of the stool should be arranged well clear of the topside tank knuckle line.

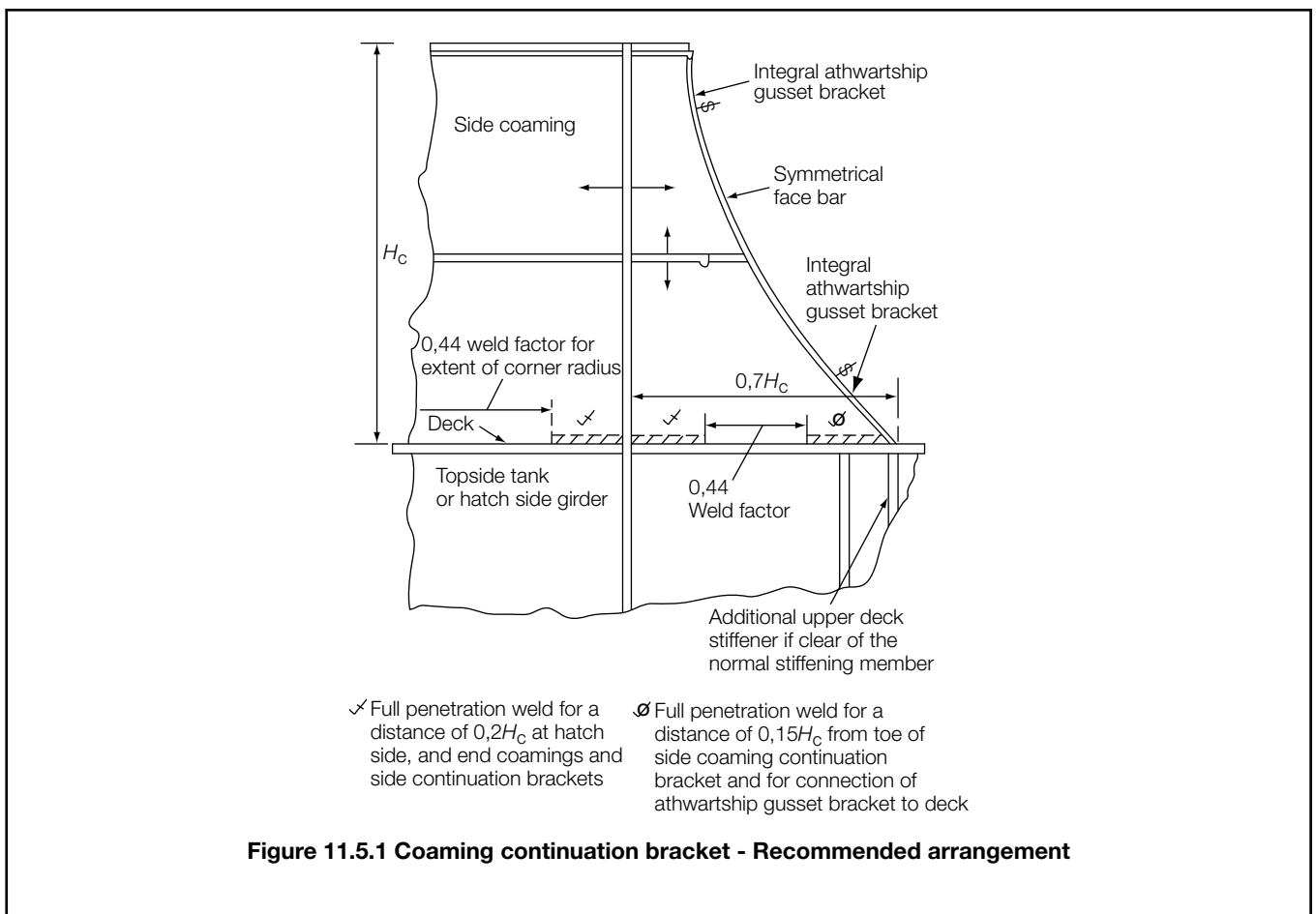

5.2.8 In bulk carriers where the hatch side coaming does not align with the topside tank vertical strake the arrangement and scantlings will be specially considered. In general, suitable underdeck girders and cantilever brackets are to be arranged taking into consideration the hatch cover loading. The underdeck girders are to continue beyond the hatch end for a distance of $2H_c$ mm. Alternative arrangements incorporating bulkhead top stool structure or cross-deck structure will be considered.

5.2.9 Extension brackets or rails arranged approximately in line with the cargo hatch side coamings and intended for the stowage of steel covers are not to be welded to a deckhouse, masthouse or to each other unless they form part of the longitudinal strength members.

5.2.10 The arrangement and scantlings of continuous hatchway coamings on the strength deck will be specially considered. The material of the coamings is to comply with Table 2.2.1 Material classes and grades and Table 2.2.2 Steel grades in Pt 3, Ch 2 Materials and is to be of the same strength level as the deck plating. Discontinuous coamings of length greater than $0,09L$ are also to satisfy this requirement.

5.2.11 Where containers are carried on multi-panel hatch covers, the hatch coaming in way of the loaded panel will be required to be reinforced to resist the lateral loads imposed on the coaming due to rolling of the ship. Thrust blocks are to be fitted on the

coaming rest bar to prevent the covers from moving. Where one-piece hatch covers are fitted with locating devices, the coamings are to be reinforced in way of the locators.

5.2.12 Cut outs in the top of hatch coamings are to be avoided. Where these are necessary for the securing devices they are to be circular or elliptical in shape. Also any local reinforcements should be given a tapered transition in the longitudinal direction with a taper the rate of which should not exceed 1 in 3. Cut-outs and drain holes are to be avoided in the hatch side coaming continuation brackets. Where these are necessary the size, shape and position will be specially considered.

5.2.13 Material for hatch coamings is to be steel, according to the requirements for ship's hull. Alternative materials will be subject to special consideration.

5.2.14 Secondary stiffeners of hatch coamings are to be continuous over the breadth and length of hatch coamings.

5.2.15 Longitudinal hatch coamings with a length exceeding $0,1L$ m are to be provided with tapered brackets or equivalent transitions and a corresponding substructure at both ends. At the end of the brackets they are to be connected to the deck by full penetration welds of minimum 300 mm in length.

5.2.16 Hatch coamings and supporting structures are to be adequately stiffened to accommodate the loading from hatch covers, in longitudinal, transverse and vertical directions. Structures under deck are to be checked against the load transmitted by coaming stays.

5.2.17 On ships carrying cargo on deck, such as timber, coal or coke, coaming stays are to be spaced not more than 1,5 m apart.

5.2.18 Coaming plates are to extend to the lower edge of the deck beams; they are to be flanged or fitted with face bars or half-round bars. *Figure 11.5.2 Example for the extent of coaming plates* gives an example.

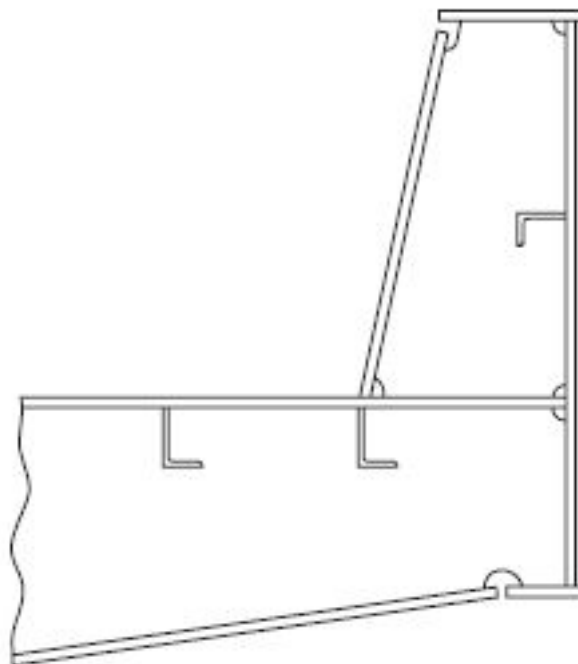

Figure 11.5.2 Example for the extent of coaming plates

5.3 Strength criteria

5.3.1 The strength requirements in this Section are applicable to hatch coamings of stiffened plate construction.

5.3.2 The local net plate thickness of weather deck hatch coamings is not to be less than the larger of the following values:

$$t = 0,0142s \sqrt{\frac{p_A}{0,95 \sigma_o}} \text{ in mm}$$

$$t_{\min} = 6 + \frac{L_1}{100} \text{ in mm}$$

= where

s = stiffener spacing, in mm

L₁ = *L* need not be taken greater than 300 metres

p_A = pressure, in kN/m², as defined in *Pt 3, Ch 11, 2.3 Load model 2.3.3*

= Longitudinal strength aspects are to be observed.

5.3.3 Secondary stiffeners of coamings must be continuous at the coaming stays. For stiffeners with both ends constrained, the elastic net section modulus *Z* in cm³ and net shear area *A_s* in cm², calculated on the basis of net thickness, are not to be less than:

$$Z = \frac{0,083}{\sigma_o} s l^2 p_A \text{ cm}^3$$

$$A_s = \frac{0,01s l p_A}{\sigma_o} \text{ cm}^2$$

= where

l = secondary stiffener span, in metres, to be taken as the spacing of coaming stays

s = stiffener spacing in mm

p_A = pressure, in kN/m², as defined in *Pt 3, Ch 11, 2.3 Load model 2.3.3*.

5.3.4 For sniped stiffeners at coaming corners, section modulus and shear area at the fixed support are to be increased by 35 per cent. The gross thickness of the coaming plate at the sniped stiffener end is not to be less than:

$$t = 19,6 \sqrt{\frac{0,001s p_A (l - 0,0005 s)}{\sigma_o}} \text{ in mm}$$

= where

p_A = pressure, in kN/m², as defined in *Pt 3, Ch 11, 2.3 Load model 2.3.3*.

5.3.5 Coaming stays are to be designed for the loads transmitted through them, and permissible stresses according to *Pt 3, Ch 11, 2.4 Allowable stress and deflection 2.4.1*.

5.3.6 The net section modulus *Z* of coaming stays, with a height of *h_s* < 1,6 m and which are to be designed for the load **p_A**, is not to be less than:

$$Z = \frac{526}{\sigma_o} e h_s^2 p_A \text{ in cm}^3$$

where

e = spacing of coaming stays, in metres

p_A = pressure, in kN/m², as defined in *Pt 3, Ch 11, 2.3 Load model 2.3.3*.

5.3.7 Coaming stays of coamings having a height of 1,6 m or more are to be designed using direct calculations under consideration of the permissible stresses according to *Pt 3, Ch 11, 2.4 Allowable stress and deflection 2.4.1*. The effective breadth of the coaming plate is not to be larger than the effective plate breadth according to *Pt 3, Ch 11, 2.10 Strength calculations 2.10.2*.

5.3.8 Coaming stays are to be supported by appropriate substructures. Face-plates may be included in the calculation only if an appropriate substructure is provided and welding ensures an adequate joint.

5.3.9 The web gross thickness of coaming stays at the root point is not to be less than:

$$t_w = \frac{2 e h_s p_A}{\sigma_o h_w} + t_c$$

= where

h_w = web height of coaming stay at its lower end, in metres

t_c = corrosion addition, in mm, according to *Pt 3, Ch 11, 1.1 Application 1.1.13*

p_A = pressure, in kN/m², as defined in *Pt 3, Ch 11, 2.3 Load model 2.3.3*.

5.3.10 Webs of coaming stays are to be connected to the deck by fillet welds on both sides with a throat thickness of $a = 0,44t_w$.

5.3.11 For coaming stays which transfer friction forces at hatch cover supports, sufficient fatigue strength is to be verified, see *Pt 3, Ch 11, 4.2 Steel covers – Clamped and gasketed 4.2.5*.

5.3.12 Hatch coamings which are part of the longitudinal hull structure are to be designed according to the requirements for longitudinal strength in *Pt 3, Ch 4 Longitudinal Strength*.

5.3.13 For structural members welded to coamings and for cut-outs in the top of coamings, sufficient fatigue strength is to be verified.

5.4 Rest bars in hatchways

5.4.1 Rest bars are to provide at least 65 mm bearing surface and are to be aligned if required to suit the slope of the hatches.

5.5 Loading in excess of Rule requirements

5.5.1 For weather deck hatch side coamings forming part of a hatch side girder subjected to loading exceeding that defined in *Pt 3, Ch 11, 2.3 Load model*, see *Pt 4, Ch 1, 4 Deck structure*.

■ Section 6 Miscellaneous openings

6.1 Small hatchways on exposed decks

6.1.1 Hatches which:

- are designed for access to spaces below the deck;
- are capable of being closed weathertight or watertight, as applicable;
- have an opening 2,5 m² or less;
- are located on the exposed deck over the forward 0,25L of the ship's rule length;
- are on a ship of sea-going service of length 80 m or more, where the height of the exposed deck in way of the hatch is less than 0,1L or 22 m above the summer load waterline, whichever is the lesser;

are to comply with the requirements of *Pt 3, Ch 11, 6.6 Small hatchways on exposed fore decks*. All other small hatchways or access openings in the positions defined in *Pt 3, Ch 11, 1.1 Application 1.1.6* are to comply with the following requirements.

6.1.2 The number and size of hatchways and other access openings are to be kept to the minimum consistent with the satisfactory operation of the ship.

6.1.3 The height of coamings is to be in accordance with *Pt 3, Ch 11, 5.1 General 5.1.1*. Lower heights may be considered in relation to operational requirements and the nature of the spaces to which access is given.

6.1.4 Rope hatches may be accepted with reduced coamings, but generally not less than 380 mm, provided they are well secured and closed before the ship leaves port. A suitable notice is to be displayed at the hatch stating that it is to be closed whilst the ship is at sea.

6.1.5 The thickness of the coamings is to be not less than the Rule minimum thickness for the deck inside line of openings for that position, or 11 mm, whichever is the lesser. Stiffening of the coaming is to be appropriate to its length and height.

6.1.6 Hatch covers are to be of steel, weathertight and generally hinged. The means of securing are to be such that weathertightness can be maintained in any sea condition. Where toggles are fitted, their diameter and spacing are to be in accordance with ISO Standard or equivalent.

6.1.7 Hinges are not to be used as securing devices unless specially considered.

6.1.8 The thickness of covers is to be not less than the Rule minimum thickness inside the line of openings for the deck at that point, or 8 mm, whichever is the lesser.

6.1.9 The covers are to be adequately stiffened.

6.1.10 To facilitate a swift and safe means of escape to the lifeboat and life raft embarkation deck, the following provisions apply to overhead hatches fitted along the escape routes addressed by SOLAS *Regulation 13 - Means of escape*:

- (a) escape hatches and their securing devices shall be of a type which can be opened from both sides;
- (b) the maximum force needed to open the hatch cover should not exceed 150 N; and
- (c) the use of a spring equalising, counterbalance or other suitable device on the hinge side to reduce the force needed for opening is acceptable.

6.1.11 Small hatches, including escape hatches, are to be situated clear of cargo containment areas, particularly in the case of offshore supply ships.

6.1.12 Where portable plates are required in decks for unshipping machinery, or for other similar reasons, they may be accepted provided they are of equivalent strength to the unpierced deck and are secured by gaskets and closely spaced bolts at a pitch not exceeding five diameters.

6.1.13 Satisfactory means are to be provided to prevent inadvertent flooding of chain lockers. *See Pt 3, Ch 13, 8.10 Structural requirements associated with anchoring 8.10.5 and Pt 3, Ch 13, 8.10 Structural requirements associated with anchoring 8.10.7.*

6.1.14 Where permitted by the National Authority, access hatch coaming heights may be reduced on ships engaged on protected or extended protected water service. Coaming heights are to be as high as practicable with a minimum height of 230 mm.

6.2 Manholes and flush scuttles

6.2.1 Manholes and flush scuttles fitted in Positions 1 and 2, or within superstructures other than enclosed superstructures, are to be closed by substantial covers capable of being made watertight. Unless secured by closely spaced bolts, the covers are to be permanently attached.

6.3 Hatchways within enclosed superstructures or 'tween decks

6.3.1 The requirements of *Pt 3, Ch 11, 6.1 Small hatchways on exposed decks* are to be complied with where applicable.

6.3.2 Access hatches within a superstructure or deckhouse in Position 1 or 2 need not be provided with means for closing if all openings in the surrounding bulkheads have weathertight closing appliances.

6.4 Companionways, doors and accesses on weather decks

6.4.1 Companionways on exposed decks are to be of equivalent construction, weathertightness and strength to a deckhouse in the same position and effectively secured to the deck.

6.4.2 Access openings in:

- (a) bulkheads at ends of enclosed superstructures;
- (b) deckhouses or companionways protecting openings leading into enclosed superstructures or to spaces below the freeboard deck; and
- (c) deckhouse on a deckhouse protecting an opening leading to a space below the freeboard deck

are to be fitted with doors of steel or other equivalent material, permanently and strongly attached to the bulkhead and framed, stiffened and fitted so that the whole structure is of equivalent strength to the unpierced bulkhead, and weathertight when closed. The doors are to be gasketed and secured weathertight by means of clamping devices or equivalent arrangements, permanently attached to the bulkhead or to the door. Doors are generally to open outwards and are to be capable of being operated and secured from both sides. The sill heights are to be as required by *Pt 3, Ch 11, 6.4 Companionways, doors and accesses on weather decks 6.4.5. See also Pt 3, Ch 11, 7 Tanker access arrangements and closing appliances and Pt 4, Ch 9, 13 Access arrangements and closing appliances and Pt 4, Ch 11, 1 General* and the Rules for Ships for Liquid Chemicals, *Chapter 3*

concerning access openings in tankers, chemical tankers and ore or oil ships. Double doors are to be equivalent in strength to the unpierced bulkhead, and in Position 1, a centre pillar is to be provided which may be portable.

6.4.3 Elsewhere doors may be of hardwood not less than 50 mm in thickness or of equivalent material and strength.

6.4.4 Fixed lights in doors in Positions 1 and 2 are to comply with the requirements for side scuttles as given in *Pt 3, Ch 11, 6.5 Side scuttles, windows and skylights 6.5.1* and *Pt 3, Ch 11, 6.5 Side scuttles, windows and skylights 6.5.2*. Hinged steel deadlights may be external.

6.4.5 The height of doorway sills above deck sheathing, if fitted, is to be not less than 600 mm in Position 1, and not less than 380 mm in Position 2.

6.4.6 Where access is provided from the deck above as an alternative to access from the freeboard deck, the height of sill into a bridge or a poop is to be not less than 380 mm. The same requirement applies to deckhouses on the freeboard deck. The sill height for doorways in a forecabin, if protecting a companionway, is to be 600 mm regardless of whether or not access is provided from above. If not protecting a companionway, the sill height may be 380 mm.

6.4.7 When the closing appliances of openings in superstructures and deckhouses do not comply with *Pt 3, Ch 11, 6.4 Companionways, doors and accesses on weather decks 6.4.2*, interior deck openings are to be treated as if exposed on the weather deck.

6.4.8 Where an access opening, in the top of a deckhouse situated on a raised quarterdeck, gives access below the freeboard deck or to an enclosed superstructure, the closing appliances in the surrounding bulkheads are not required to be gasketed, provided the raised quarterdeck is at least standard height, and the deckhouse is at least standard superstructure height.

6.4.9 The height of door sills may be required to be increased on ships of Type 'A', Type 'B-100' or Type 'B-60' where this is shown to be necessary by the floatability calculations required by the *International Convention on Load Lines, 1966*.

6.4.10 Direct access from the freeboard deck to the machinery space through exposed casings is not permitted on ships of Type 'A', Type 'B-100' or Type 'B-60'. A door complying with *Pt 3, Ch 11, 6.4 Companionways, doors and accesses on weather decks 6.4.2* may, however, be fitted in an exposed machinery casing on these ships, provided that it leads to a space or passageway which is of equivalent strength to the casing and is separated from the machinery space by a second weathertight door complying with *Pt 3, Ch 11, 6.4 Companionways, doors and accesses on weather decks 6.4.2*. The outer and inner weathertight doors are to have sill heights of not less than 600 mm and 230 mm, respectively and the space between is to be adequately drained by means of a screw plug or equivalent.

6.4.11 For a Type 'A' ship with freeboards assigned greater than, or equal to, Type 'B', inner doors are not required for direct access to the engine-room.

6.4.12 If internal access is provided from a wheelhouse in Position 2, or below, to spaces below the weather deck either directly or through other spaces, the opening should be protected by a hinged weathertight cover adequately secured, fitted on a coaming appropriate to its position, or by an equivalent arrangement, and the space adequately drained.

6.4.13 In way of a moonpool, where a working or platform deck is provided below the weather deck, openings in the surrounding bulkheads are to be kept to a minimum. Access or companionway openings are to be provided with weathertight closing appliances as for an exposed superstructure bulkhead, with 600 mm high coamings.

6.4.14 Where portable plates are required in casings for unshipping machinery, or for other similar reasons, they may be accepted provided they are of equivalent strength to the unpierced bulkhead and are secured by gaskets and close spaced bolts at a pitch not exceeding five diameters.

6.4.15 The sill heights of accesses closed by covers which are secured by closely spaced bolts or otherwise kept permanently closed at sea will be specially considered.

6.4.16 Where permitted by the National Authority, companionway coaming heights may be reduced on ships engaged on protected or extended protected water service. Coaming heights are to be as high as practicable with a minimum height of 230 mm. Where the wheelhouse is on the freeboard deck, or located in the forward quarter of the ship's length, with internal access below, a weathertight cover, fitted to a coaming not less than 230 mm high, is to be provided for the access. Alternatively, storm covers are to be provided for windows in exposed positions. The wheelhouse is to be adequately drained.

6.5 Side scuttles, windows and skylights

6.5.1 Side scuttles are defined as being round or oval openings with an area not exceeding 0,16 m².

- 6.5.2 Windows are defined as being rectangular openings generally, and round or oval openings with an area exceeding 0,16 m².
- 6.5.3 A plan showing the location of side scuttles and windows is to be submitted. Attention is to be given to any relevant Statutory Requirements of the National Authority of the country in which the ship is to be registered.
- 6.5.4 Side scuttles and windows together with their glasses and deadlights if fitted, are to be of an approved design or in accordance with a recognised National or International Standard, see also *Pt 4, Ch 4, 6.3 Windows and side scuttles* for offshore supply ships.
- 6.5.5 Side scuttles to spaces below the freeboard deck, or to spaces within the first tier of enclosed superstructures, or to first tier deckhouses on the freeboard deck protecting openings leading below or considered buoyant in stability calculations, are to be fitted with efficient, hinged, inside deadlights and capable of being effectively closed and secured watertight.
- 6.5.6 Deadlights are to be capable of being closed and secured watertight if fitted below the freeboard deck or weathertight if fitted above.
- 6.5.7 No side scuttle is to be fitted in such a position that its sill is below a line drawn parallel to the freeboard deck at side and having its lowest point 2,5 per cent of the breadth *B* above the load waterline corresponding to the summer freeboard (or timber summer freeboard if assigned), or 500 mm, whichever is the greater distance, see Fig. 11.6.1.
- 6.5.8 If the required damage stability or floatability calculations indicate that the side scuttles would become immersed at any intermediate stages of flooding or the final equilibrium waterline, these are to be of the non-opening type. Windows are not to be fitted in such locations.
- 6.5.9 Windows are not to be fitted in machinery space boundaries. However this does not preclude the use of glass in control rooms within the machinery space.
- 6.5.10 If fitted in a deckhouse in Position 1, windows are to be provided with strong, hinged, steel, weathertight storm covers. However, if there is an opening leading below deck in this deckhouse, this opening is to be treated as being on an exposed deck and is to be protected as required by *Pt 3, Ch 11, 6.4 Companionways, doors and accesses on weather decks 6.4.2*.
- 6.5.11 Windows are not to be fitted below the freeboard deck, in first tier end bulkheads or sides of enclosed superstructures, or in first tier deckhouses that are considered buoyant in stability calculations.
- 6.5.12 Side scuttles and windows at the shell in Position 2, protecting direct access below, are to be provided with strong permanently attached deadlights.
- 6.5.13 Side scuttles and windows at the shell in Position 2, not protecting direct access below, are to be provided with strong portable steel covers for 50 per cent of each size, with means for securing at each side scuttle and window.
- 6.5.14 Side scuttles and windows set inboard from the shell in Position 2, protecting direct access below, are either to be provided with strong permanently attached deadlights or, where they are accessible, strong permanently attached external steel storm covers instead of internal deadlights.
- 6.5.15 Side scuttles and windows set inboard from the shell in Position 2, not protecting direct access below, do not require deadlights or storm covers.
- 6.5.16 In Position 2, cabin bulkheads and doors are considered effective between side scuttles or windows and access below.
- 6.5.17 Windows in the shell, located at least one standard height of superstructure above the lowest Position 2 deck, are to be provided with strong portable internal storm covers for 25 per cent of each size of window, with means of securing being provided at each window.
- 6.5.18 Where windows are permitted in an exposed bulkhead on the weather deck in the forward 0,25L \perp , strong external storm covers which may be portable and stored adjacent are to be provided.

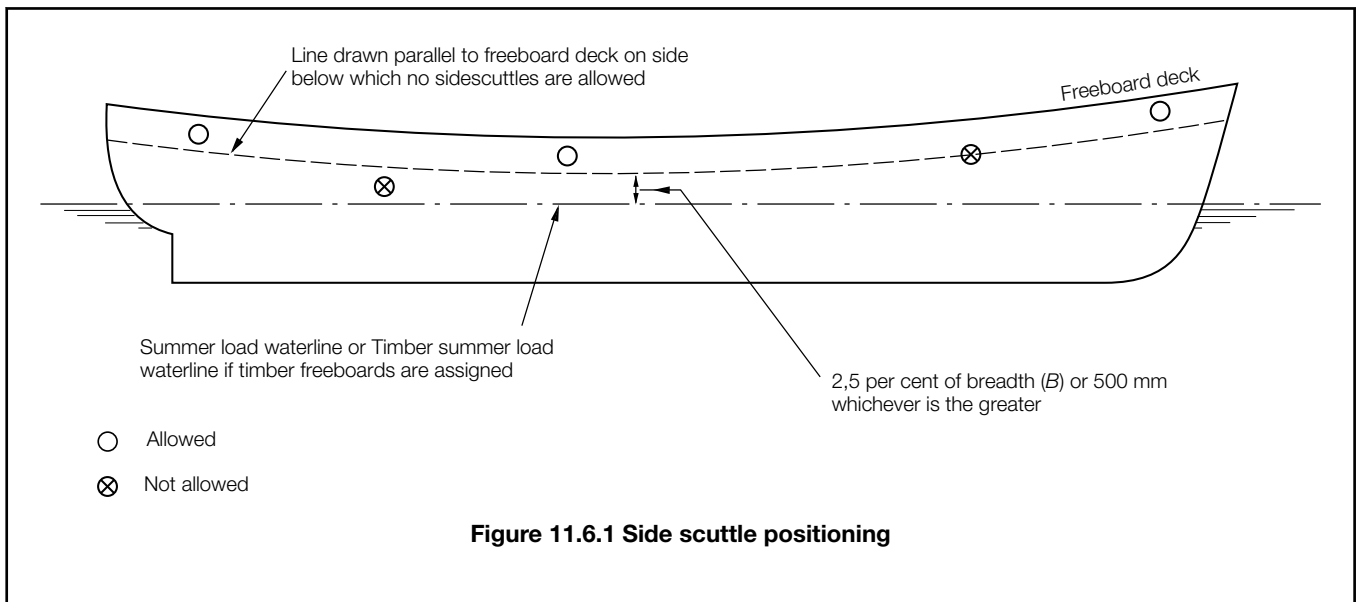

6.5.19 Where the wheelhouse is in Position 2, in lieu of storm covers being provided for the wheelhouse windows, a weathertight cover, fitted to a coaming of not less than 230 mm in height around the internal stairway opening within the wheelhouse, may be accepted. If this arrangement is accepted, adequate means of draining the wheelhouse are to be provided.

6.5.20 If necessary, for practical considerations, the storm covers may be in two parts.

6.5.21 Deckhouses situated on a raised quarter deck may be treated as being in Position 2 as far as the provision of deadlights is concerned, provided the height of the raised quarter deck is equal to, or greater than, the standard height.

6.5.22 Skylights, where fitted, are to be of substantial construction and securely attached to their coamings. The height of the lower edge of opening is to be as required by Pt 3, Ch 11, 5.1 General 5.1.1. The scantlings of the coaming are to be as required by this Section or Pt 3, Ch 11, 5 Hatch coamings, as appropriate. The thickness of glasses in fixed or opening skylights is to be appropriate to their size and position as required for side scuttles or windows. Glasses in any position are to be protected from mechanical damage, and where fitted in Positions 1 or 2 are to be provided with robust deadlights or storm covers permanently attached. Cargo pump room and machinery space skylights are not to contain glass.

6.5.23 Skylights to cargo pump rooms are to be capable of being closed from outside the pump room.

6.5.24 Laminated toughened safety glass may also be used for windows but the total thickness will need to be greater than that required for the equivalent sized window using toughened safety glass. The equivalent thickness of laminated toughened safety glass is to be determined from the following formula:

$$T_{L1}^2 + T_{L2}^2 + \dots T_{Ln}^2 = T_S^2$$

where

n = number of laminates

T_L = thickness of glass laminate

T_S = thickness of toughened safety glass.

Alternative arrangements that do not meet the above thickness requirement will be specially considered, provided that equivalent strength and bending stiffness to that of a single, thermally toughened pane of thickness, t_s , can be demonstrated in a four-point bending test in accordance with EN-ISO 1288-3 or an equivalent recognised National or International Standard, using not less than ten samples. The lower limit of the 90 per cent confidence level interval for the laminated pane shall not be less than the same for monolithic toughened safety glass. Small scale punch test or ring-in-ring test methods shall not be used.

6.5.25 Rubber frames are not acceptable for windows in Positions 1 and 2, and are not generally acceptable in any other position in external casings. Any proposals to fit rubber frames are to be submitted for consideration, and are to be acceptable to the administration. The proposed locations, frame dimensions, glass thicknesses and the results of any tests carried out, are to be forwarded.

6.6 Small hatchways on exposed fore decks

6.6.1 For the application of the following requirements, see *Pt 3, Ch 11, 6.1 Small hatchways on exposed decks 6.1.1*.

6.6.2 The number and size of hatchways and other access openings are to be kept to the minimum consistent with the satisfactory operation of the ship.

6.6.3 The height of coamings is to be in accordance with *Pt 3, Ch 11, 5.1 General 5.1.1*. Lower heights may be considered in relation to operational requirements and the nature of the spaces to which access is given.

6.6.4 Rope hatches may be accepted with reduced coamings, but generally not less than 380 mm, provided they are well secured and closed before the ship leaves port. A suitable notice is to be displayed at the hatch stating that it is to be closed whilst the ship is at sea.

6.6.5 Where permitted by the National Authority, access hatch coaming heights may be reduced on ships engaged on protected or extended protected water service. Coaming heights are to be as high as practicable with a minimum height of 230 mm.

6.6.6 The thickness of the coamings is to be not less than the Rule minimum thickness for the deck inside line of openings for that position, or 11 mm, whichever is the lesser.

6.6.7 The upper edge of the hatchway coamings is to be suitably reinforced by a horizontal section, normally not more than 170 to 190 mm from the upper edge of the coamings.

6.6.8 Hatches are to be fitted with primary securing devices such that their hatch covers can be secured in place and weather-tight by means of a mechanism employing any one of the following methods:

- (a) Butterfly nuts tightening onto forks (clamps),
- (b) Quick acting cleats, or
- (c) Central locking device.

Emergency escape hatches are excluded from options (a) and (b).

6.6.9 Dogs (twist tightening handles) with wedges are not acceptable as primary securing devices.

6.6.10 Escape hatches are to be capable of being opened from either side and are to have a quick-acting type securing device, e.g. one action wheel handle central locking device for latching/unlatching the hatch cover.

6.6.11 For a primary securing method using butterfly nuts, the forks (clamps) are to be of robust design. They are to be designed to minimise the risk of butterfly nuts being dislodged while in use; by means of curving the forks upward, a raised surface on the free end, or a similar method. The plate thickness of unstiffened steel forks is not to be less than 16 mm. An example arrangement is shown in *Figure 11.6.3 Example of a primary securing method*.

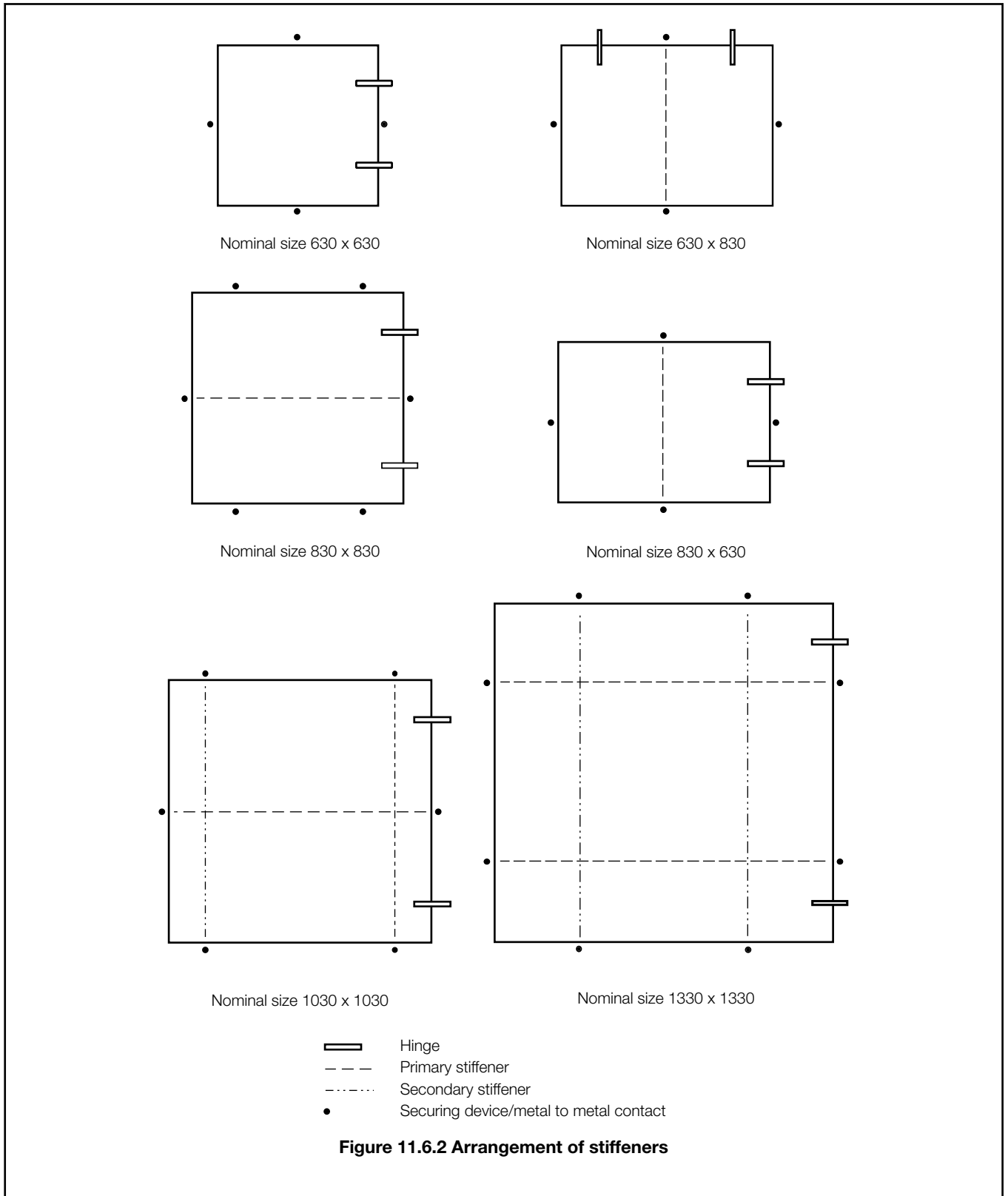

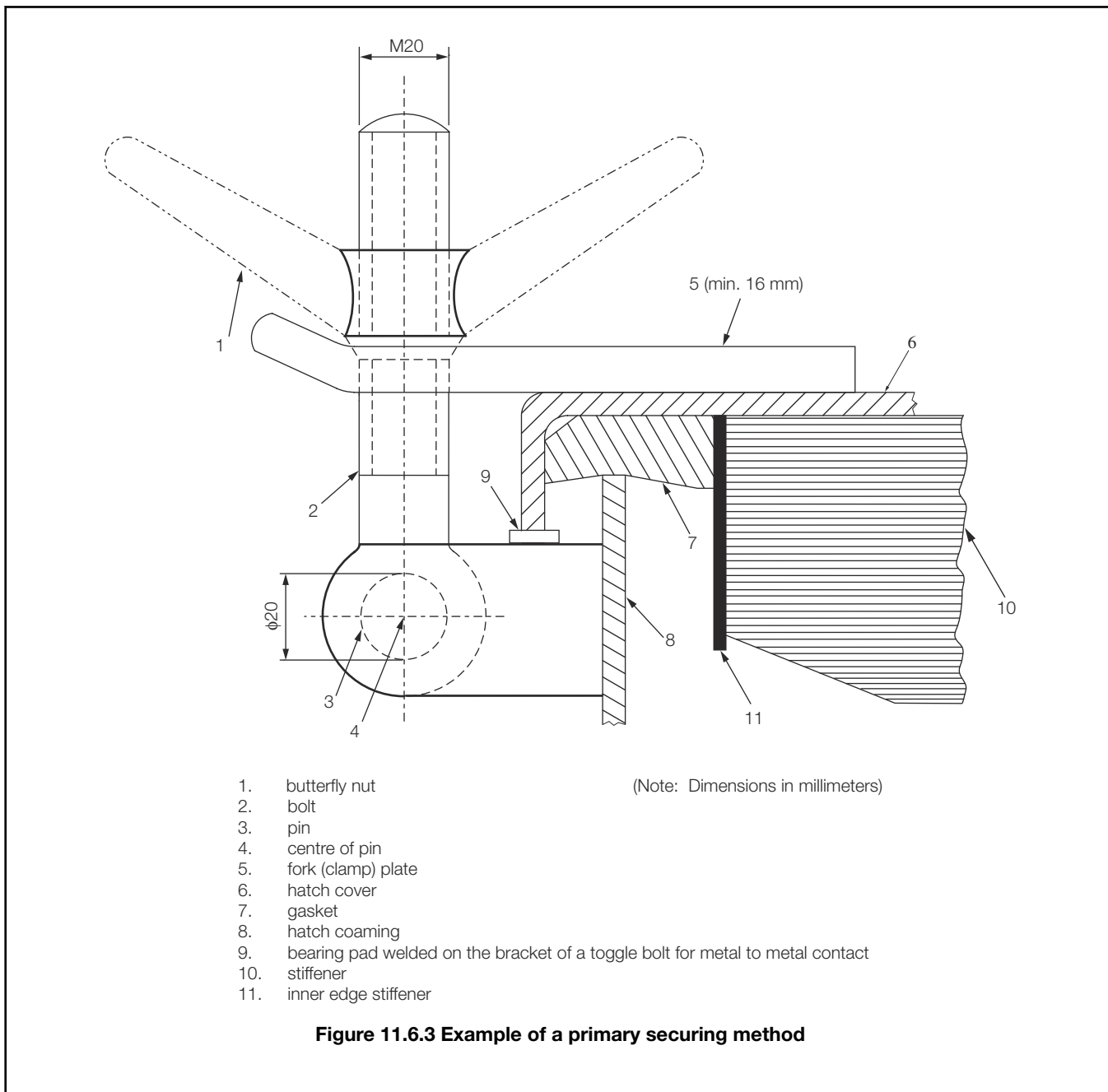

6.6.12 The hatch cover is to be fitted with a gasket of elastic material. This is to be designed to allow a metal to metal contact at a designed compression and to prevent over compression of the gasket by green sea forces that may cause the securing devices to be loosened or dislodged. The metal-to-metal contacts are to be arranged close to each securing device in accordance with *Figure 11.6.2 Arrangement of stiffeners*, and of sufficient capacity to withstand the bearing force.

6.6.13 The primary securing method is to be designed and manufactured such that the designed compression pressure can be achieved by one person without the need of any tools.

6.6.14 For small rectangular steel hatch covers, the plate thickness, stiffener arrangement and scantlings are to be in accordance with *Table 11.6.1 Scantlings for small steel hatch covers on exposed deck* and *Figure 11.6.2 Arrangement of stiffeners*. Stiffeners, where fitted, are to be aligned with the metal-to-metal contact points required in *Pt 3, Ch 11, 6.6 Small hatchways on exposed fore decks 6.6.11*, see *Figure 11.6.2 Arrangement of stiffeners*. Primary stiffeners are to be continuous. All stiffeners are to be welded to the inner edge stiffener, see *Figure 11.6.3 Example of a primary securing method*.

Table 11.6.1 Scantlings for small steel hatch covers on exposed deck

nominal size (mm x mm)	cover plate thickness (mm)	primary stiffeners	secondary stiffeners
		Flat bar (mm x mm); number	
630 x 630	8	–	–
630 x 830	8	100 x 8,1	–
830 x 630	8	100 x 8,1	–
830 x 830	8	100 x 10,1	–
1030 x 1030	8	120 x 12,1	80 x 8,2
1330 x 1330	8	150 x 12,2	100 x 10,2

- 6.6.15 For hatch covers constructed of materials other than steel, the required scantlings are to provide equivalent strength.
- 6.6.16 For small hatch covers of circular or similar shape, the cover plate thickness and reinforcement are to be of equivalent strength to that of the small rectangular steel hatch covers described in *Pt 3, Ch 11, 2.2 Stiffener arrangement 2.2.1*.
- 6.6.17 For hatch covers located on the deck forward of the fore-most cargo hatch, the hinges are to be fitted such that the predominant direction of green sea will cause the cover to close. The hinges are normally to be located on the fore edge.
- 6.6.18 On small hatches located between the main hatches, for example between Numbers 1 and 2, the hinges are to be placed on the fore edge or outboard edge, whichever is practicable for protection from green water in beam sea and bow quartering conditions.
- 6.6.19 Hatches, excluding emergency escape hatches, are to be fitted with an independent secondary securing device, e.g. by means of a sliding bolt, a hasp or a backing bar of slack fit, which is capable of keeping the hatch cover in place, even in the event that the primary securing device became loosened or dislodged. It is to be fitted on the side opposite to the hatch cover hinges.
- 6.6.20 Small hatches, including escape hatches, are to be situated clear of cargo containment areas, particularly in the case of offshore supply ships.
- 6.6.21 Where portable plates are required in decks for unshipping machinery, or for other similar reasons, they may be accepted provided they are of equivalent strength to the unpierced deck and are secured by gaskets and closely spaced bolts at a pitch not exceeding five diameters.
- 6.6.22 Satisfactory means are to be provided to prevent inadvertent flooding of chain lockers, see *Pt 3, Ch 13, 8.10 Structural requirements associated with anchoring 8.10.5* and *Pt 3, Ch 13, 8.10 Structural requirements associated with anchoring 8.10.7*.

■ **Section 7**
Tanker access arrangements and closing appliances

7.1 Materials

- 7.1.1 Covers for access hatches, tank cleaning and other openings to cargo tanks and adjacent spaces are to be manufactured from steel complying with the *Rules for the Manufacture, Testing and Certification of Materials, July 2015*.
- 7.1.2 Consideration will be given to the use of bronze, brass or other materials; however, aluminium alloy is not to be used for the covers of any openings to tanks.
- 7.1.3 Synthetic materials will be considered, taking into account their fire resistance and physical and chemical properties in relation to the intended operating conditions. Details of the properties of the material, the design of the cover and the method of manufacture are to be submitted for approval.
- 7.1.4 The hatch cover packing material is to be compatible with the cargoes to be carried and is to be efficiently held in place.

7.2 Cargo tank access hatchways

7.2.1 Attention is drawn to IMO Resolutions concerning safe access to, and working in, large tanks.

7.2.2 Oiltight hatchways are to be kept to the minimum size required to provide reasonable access and ventilation. Where tanks are large or subdivided by wash bulkheads, additional hatchways may be required. In determining the size and location of hatchways, consideration should be given to the handling of materials and staging for maintenance in the tank.

7.2.3 The size and location of hatchways should also take into account access for personnel wearing breathing apparatus, and removal of injured personnel (possibly on a stretcher) from the bottom of the tank.

7.2.4 The height of hatch coaming is to be not less than 600 mm, measured above the upper surface of the freeboard deck, unless a lower height is permitted by the Administration of the country in which the ship is to be registered.

7.2.5 Taking account of sheer and camber, the height of any cargo tank hatch coaming is to be such as to ensure that the top of the hatch coaming is above the highest point of the tank over which it is fitted.

7.2.6 The height of the coaming may be required to be increased if this is shown to be necessary by the floatability calculations required by the *Load Lines, 1966/1988 - International Convention on Load Lines, 1966, as Amended by the Protocol of 1988*

7.2.7 The thickness of the coaming plate is to be not less than 10 mm, but may be required to be increased, and edge stiffening fitted, where the coaming height exceeds 600 mm.

7.2.8 Unstiffened plate covers are to be not less than 12,5 mm in thickness, but if the area of the cover exceeds 1,2 m² this thickness may be required to be increased or stiffening fitted.

7.2.9 Unstiffened covers are to be secured by fastenings spaced not more than 600 mm apart on circular hatchways. On rectangular hatchways the spacing of fastenings is generally not to exceed 450 mm, and the distance between hatch corners and adjacent fastenings is to be not more than 230 mm.

7.2.10 The arrangement of fastenings on stiffened hatchway covers and covers of special design will be specially considered.

7.2.11 Where the cover is hinged, adequate stiffening of the coaming and cover in way of the hinge is to be provided. In general, hinges are not to be used as securing devices for the cover.

7.3 Enlarged cargo tank access openings

7.3.1 Proposals to fit enlarged cargo tank accesses closed by bolted plate covers will be considered. Such openings may be of extended dimensions for ease of access and evacuation of personnel, see *Pt 3, Ch 11, 7.2 Cargo tank access hatchways* 7.2.3, and may incorporate a smaller access hatch for normal use constructed as required by *Pt 3, Ch 11, 7.2 Cargo tank access hatchways*.

7.3.2 The plate cover is to be not less than 15 mm in thickness and is to be secured by closely spaced studs to a ring of suitable dimensions, welded to the deck. The studs are not to penetrate the deck plating.

7.4 Miscellaneous openings

7.4.1 Small openings for tank cleaning, ullage and similar purposes may be closed by flush covers which are to be not less than 12,5 mm in thickness and secured by studs not more than 100 mm apart. Studs are to be arranged in a ring of suitable width and thickness attached to the deck, and are not to penetrate the deck plating.

7.4.2 Small diameter holes provided for staging wires are to be closed by plugs of an approved pattern. The plugs are to be provided with a thick washer of suitable material which is also compatible with the intended cargoes. Spare plugs equal to at least 10 per cent of the number of holes are to be provided and maintained on board, see also *Pt 4, Ch 9, 4 Hull envelope plating*. If these openings are threaded they are to be protected while in use with a protective sleeve of suitable material.

7.5 Access to spaces other than cargo tanks

7.5.1 Access to clean ballast or dry tanks and to cofferdams may be either by access hatch or by manhole generally complying with the preceding requirements.

7.6 Equivalentents

7.6.1 Alternative access cover designs and securing arrangements will be considered on the basis of equivalence to the above requirements and taking into account any relevant National Requirements.

7.7 Other openings

7.7.1 For access to structure within cargo tanks, see Pt 4, Ch 9, 13 Access arrangements and closing appliances.

■ **Section 8**
Side and stern doors and other shell openings

8.1 Symbols

8.1.1 The symbols used in this Section are defined as follows:

d = distance between closing devices, in metres

k = material factor, see Pt 3, Ch 2, 1.2 Steel, but is not to be taken less than 0,72 unless demonstrated otherwise by a direct strength analysis with regard to relevant modes of failure

l = moment of inertia, in cm^4 , of the stiffener or girder, in association with an effective width of attached plating determined in accordance with Pt 3, Ch 3, 3 Structural idealisation

σ = bending stress, in N/mm^2 (kgf/mm^2)

σ_e = equivalent stress, in N/mm^2 (kgf/mm^2)

$$= \sqrt{(\sigma^2 + 3\tau^2)}$$

σ_o = minimum yield stress of the bearing material, in N/mm^2 (kgf/mm^2)

τ = shear stress, in N/mm^2 (kgf/mm^2).

8.2 General

8.2.1 These requirements cover cargo and service doors in the ship side (abaft the collision bulkhead) and stern area, below the freeboard deck and in enclosed superstructures.

8.2.2 For the requirements of bow doors, see Pt 4, Ch 2, 8 Bow doors and inner doors.

8.2.3 Side and stern doors are to be so fitted as to ensure tightness and structural integrity commensurate with their location and the surrounding structure, see also Pt 3, Ch 1, 6.3 Weathertight 6.3.2 and Pt 3, Ch 1, 6.4 Watertight 6.4.2.

8.2.4 In general, and for passenger ships in particular, the lower edge of door openings is not to be below a line drawn parallel to the freeboard deck at side, which has at its lowest point at least 230 mm above the upper edge of the uppermost Load Line.

8.2.5 When the lower edge is below the line specified in Pt 3, Ch 11, 8.2 General 8.2.4, the arrangement will be specially considered. Special consideration is to be given to preventing the spread of leakage water over the deck. The reference to the uppermost Load Line is to be taken as the tropical fresh waterline or, if timber freeboards are assigned, the timber tropical fresh waterline.

8.2.6 Watertight doors below the freeboard deck, with the exception of pilot doors which are to open inwards, are to open outwards. Weathertight doors are generally to be arranged to open outwards, however inward opening doors will be considered provided these satisfy the requirements of Pt 3, Ch 11, 8.2 General 8.2.7.

8.2.7 Inward opening doors situated in the first two 'tween decks above the summer load waterline are to be fitted with a second independent securing device, such as a strongback or equivalent arrangement, capable of providing weathertight integrity. Where the consequences of water ingress due to failure of the door are minimal, such as a small pilot door giving access to a watertight trunk leading to the bulkhead deck, the required enhancements will be specially considered.

8.2.8 For passenger ships the following are also applicable:

(a) Gangway, cargo and service ports fitted below the margin line, see Pt 3, Ch 3, 4.3 After peak bulkhead, are to satisfy the strength requirements given for side doors in this Section. They are to be effectively closed and secured watertight before the

ship leaves port, and are to be kept closed during navigation. Such ports are not to have their lowest point below the deepest subdivision Load Line.

- (b) Where the inboard end of a rubbish chute is below the margin line in a passenger ship, the inboard end cover is to be watertight and, in addition to the discharge flap interlock, a screwdown automatic non-return valve is to be fitted in an easily accessible position above the deepest subdivision. The valve is to be controlled from a position above the bulkhead deck and provided with an open/shut indicator, and kept closed when not in use. A suitable notice is to be displayed at the valve position.

8.2.9 For ships complying with the requirements of this Section, the securing, supporting and locking devices are defined as follows:

- (a) A securing device is used to keep the door closed by preventing it from rotating about its hinges or other pivoted attachments to the ship.
- (b) A supporting device is used to transmit external and internal loads from the door to a securing device and from the securing device to the ship's structure, or a device other than a securing device, such as a hinge, stopper or other fixed device, that transmits loads from the door to the ship's structure.
- (c) A locking device locks a securing device in the closed position.

8.2.10 Ro-ro cargo spaces are spaces not normally subdivided in any way and extending to either a substantial length or the entire length of the ship, in which motor vehicles with fuel in their tanks for their own propulsion and/or goods (packaged or in bulk, in or on rail or road cars, vehicles (including road or rail tankers), trailers, containers, pallets, demountable tanks in or on similar stowage units or other receptacles) can be loaded and unloaded normally in a horizontal direction.

8.2.11 Special category spaces are those enclosed spaces above and below the bulkhead deck, into and from which vehicles can be driven and to which passengers have access, and which may be accommodated on more than one deck where total overall clear height for vehicles does not exceed 10 m.

8.3 Scantlings

8.3.1 In general the strength of side and stern doors is to be equivalent to the strength of the surrounding structure.

8.3.2 Door openings in the side shell are to have well rounded corners and adequate compensation is to be arranged with web frames at sides and stringers or equivalent above and below, see *Pt 4, Ch 1, 5 Shell envelope plating*.

8.3.3 Doors are to be adequately stiffened, and means are to be provided to prevent movement of the doors when closed. Adequate strength is to be provided in the connections of the lifting/manoeuvring arms and hinges to the door structure and to the ship structure.

8.3.4 The thickness of the door plating is to be not less than the shell plating calculated with the door stiffener spacing, and in no case to be less than the minimum adjacent shell thickness.

8.3.5 Where stern doors are protected against direct wave impact by a permanent external ramp, the thickness of the stern door plating may be reduced by 20 per cent relative to the requirements of *Pt 3, Ch 11, 8.3 Scantlings 8.3.4*. Those parts of the stern door which are not protected by the ramp are to have the thickness of plating in full compliance with *Pt 3, Ch 11, 8.3 Scantlings 8.3.4*.

8.3.6 Where higher tensile steel is proposed, the plating thickness required in *Pt 3, Ch 11, 8.3 Scantlings 8.3.4* and *Pt 3, Ch 11, 8.3 Scantlings 8.3.5* may be reduced by \sqrt{k} .

8.3.7 The section modulus of horizontal or vertical stiffeners is to be not less than required for the adjacent shell framing using the actual stiffener spacing. Consideration is to be given, where necessary, to differences in fixity between ship's frames and door stiffeners.

8.3.8 Where necessary, door secondary stiffeners are to be supported by primary members constituting the main stiffening elements of the door.

8.3.9 The scantlings of such primary members are to be based on direct strength calculations. Normally, formulae for simple beam theory may be applied to determine the bending stress. Members are to be considered to have simply supported end connections. The design load is the uniformly distributed external sea pressure, p_e , as defined in *Pt 3, Ch 11, 8.8 Operating and Maintenance Manual 8.8.1*. For minimum scantlings, p_e is to be taken as 25 kN/m² (2,55 tonne-f/m²) and the permissible stresses are as follows:

$$\tau = \frac{80}{k} \text{ N/mm}^2 \left(\frac{8,2}{k} \text{ kgf/mm}^2 \right)$$

$$\sigma = \frac{120}{k} \text{ N/mm}^2 \left(\frac{12,2}{k} \text{ kgf/mm}^2 \right)$$

$$\sigma_e = \frac{150}{k} \text{ N/mm}^2 \left(\frac{15,3}{k} \text{ kgf/mm}^2 \right)$$

- 8.3.10 The webs of primary members are to be adequately stiffened, preferably in a direction perpendicular to the shell plating.
- 8.3.11 The stiffness of the edges of the doors and the hull structure in way are to be sufficient to ensure weathertight integrity. Edge stiffeners/girders are to be adequately stiffened against rotation and are to have a moment of inertia not less than:

$$I = 0,8p_1 d^4 \text{ cm}^4$$

$$(I = 8p_1 d^4 \text{ cm}^4)$$

where

p_1 = packing line pressure along edges, not to be taken less than 50 N/cm (5,1 kgf/cm).

For edge girders supporting main door girders between securing devices, the moment of inertia is to be increased in relation to the additional force.

- 8.3.12 The buckling strength of primary members is to be specially considered.
- 8.3.13 All load transmitting elements in the design load path from door through securing and supporting devices into the ship structure, including welded connections, are to be to the same strength standard as required for the securing and supporting devices. These elements include pins, supporting brackets and back-up brackets. Where cut-outs are made in the supporting structure, the strength and stiffness will be specially considered.

8.4 Doors serving as ramps

- 8.4.1 Where doors also serve as vehicle ramps, the plating and stiffeners are to be not less than required for vehicle decks, see Pt 3, Ch 9, 3 Decks loaded by wheeled vehicles.
- 8.4.2 The design of the hinges for these doors should take into account the ship angle of trim or heel which may result in uneven loading of the hinges.

8.5 Arrangements for the closing, securing and supporting of doors

- 8.5.1 Doors are to be fitted with adequate means of closing, securing and support so as to be commensurate with the strength and stiffness of the surrounding structure. The hull supporting structure in way of the doors is to be suitable for the same design loads and design stresses as the securing and supporting devices. Where packing is required, the packing material is to be of comparatively soft type, and the supporting forces are to be carried by the steel structure only. Other types of packing may be considered. Maximum design clearance between securing and supporting devices is generally not to exceed 3 mm.
- 8.5.2 Devices are to be simple to operate and easily accessible. They are to be of a design approved by Lloyd's Register for the intended purpose.
- 8.5.3 Securing devices are to be equipped with positive locking arrangements. Arrangements are to be such that the securing devices are retained in the closed position within design limits of inclination, vibration and other motion-induced loads and in the event of loss of any actuating power supply.
- 8.5.4 Systems for door opening/closing and securing/locking are to be interlocked in such a way that they can only operate in a proper sequence. Hydraulic systems are to comply with Pt 5, Ch 14, 9 Hydraulic systems.
- 8.5.5 Means are to be provided to enable the doors to be mechanically fixed in the open position taking into account the self weight of the door and a minimum wind pressure of 1,5 kN/m² (0,153 tonne-f/m²) acting on the maximum projected area in the open position.
- 8.5.6 The spacing for cleats or closing devices should not exceed 2,5 m and there should be cleats or closing devices positioned as close to the corners as practicable. Alternative arrangements for ensuring weathertight sealing will be specially considered.

8.5.7 Control and monitoring arrangements are to comply with the applicable requirements of Pt 6, Ch 2, 19 Ship safety systems.

8.6 Design loads

8.6.1 The design force considered for the scantlings of primary members, securing and supporting devices of side shell doors and stern doors are to be taken not less than:

(a) Design forces for securing or supporting devices of doors opening inwards:

External force:

$$P_e = A p_e + P_p \text{ kN (tonne-f)}$$

Internal force:

$$P_i = P_o + 10W \text{ kN}$$

$$(P_i = P_o + 1,02W \text{ tonne-f})$$

(b) Design forces for securing or supporting devices of doors opening outwards:

External force:

$$P_e = A p_e \text{ kN (tonne-f)}$$

Internal force:

$$P_i = P_o + 10W + P_p \text{ kN}$$

$$(P_i = P_o + 1,02W + P_p \text{ tonne-f})$$

(c) Design forces for primary members:

External force:

$$P_e = A p_e + 10W \text{ kN (tonne-f)}$$

Internal force:

$$P_i = P_o + 10W \text{ kN}$$

$$(P_i = P_o + 1,02W \text{ tonne-f})$$

whichever is the greater.

The symbols used are defined as follows:

p_e = external sea pressure, in kN/m² (tonne-f/m²), determined at the centre of gravity of the door opening and is not to be taken less than:

$$= \begin{cases} \text{for } Z_G < T & 10(T - Z_G) + 25 \text{ kN/m}^2 \\ & (1,02(T - Z_G) + 2,55 \text{ tonne-f/m}^2) \\ \text{for } Z_G \geq T & 25 \text{ kN/m}^2 \\ & (2,55 \text{ tonne-f/m}^2) \end{cases}$$

= For stern doors of ships fitted with bow doors, P_e is not to be taken less than:

$$p_{emin} = 0,6\lambda C_H (0,8 + 0,6L^{0,5})^2 \text{ kN/m}^2$$

$$(p_{emin} = 0,061\lambda C_H (0,8 + 0,6L^{0,5})^2 \text{ tonne-f/m}^2)$$

T = summer draught, in metres

Z_G = height of the centre of area of the door, in m, above the base line

L = length of ship, but need not be taken greater than 200 m

λ = coefficient depending on the area where the ship is intended to be operated:

= 1 for sea-going ships

= 0,8 for ships operated in coastal waters

= 0,5 for ships operated in sheltered waters

C_H = 0,0125L for $L < 80$ m

= 1 for $L \geq 80$ m

A = area, in m^2 , of the door opening

W = weight of the door, in tonnes

P_p = total packing force, kN (tonne-f). When packing is fitted, the packing line force per unit length is to be specified, normally not to be taken less than: 5 kN/m (0,51 tonne-f/m)

P_o = the greater of P_c and 5A kN (0,5A tonne-f)

P_c = accidental force, in kN (tonne-f), due to loose cargo, etc. to be uniformly distributed over the area A and not to be taken less than 300 kN (30,6 tonne-f). For small doors such as bunker doors and pilot doors, the value of P_c may be taken as zero, provided an additional structure such as an inner ramp is fitted, which is capable of protecting the door from accidental force due to loose cargoes.

8.7 Design of securing and supporting devices

8.7.1 Securing devices and supporting devices are to be designed to withstand the forces given above using the following permissible stresses:

$$\tau = \frac{80}{k} \text{ N/mm}^2 \left(\frac{8,2}{k} \text{ kgf/mm}^2 \right)$$

$$\sigma = \frac{120}{k} \text{ N/mm}^2 \left(\frac{12,2}{k} \text{ kgf/mm}^2 \right)$$

$$\sigma_e = \frac{150}{k} \text{ N/mm}^2 \left(\frac{15,3}{k} \text{ kgf/mm}^2 \right)$$

The terms 'securing device' and 'supporting device' are defined in *Pt 4, Ch 2, 8.2 General 8.2.8*.

8.7.2 The arrangement of securing and supporting devices is to be such that threaded bolts are not to carry support forces. The maximum tensile stress in way of threads of bolts, not carrying support forces, is not to exceed:

$$\frac{125}{k} \text{ N/mm}^2 \left(\frac{12,7}{k} \text{ kgf/mm}^2 \right)$$

8.7.3 For steel to steel bearings in securing and supporting devices, the normal bearing pressure is not to exceed $0,8\sigma_o$, see *Pt 3, Ch 11, 8.1 Symbols 8.1.1*. For other bearing materials, the permissible bearing pressure is to be determined according to the manufacturer's specification. The normal bearing pressure is to be calculated by dividing the design force by the projected bearing area.

8.7.4 The distribution of the reaction forces acting on the securing and supporting devices may require to be supported by direct calculations taking into account the flexibility of the hull structure and the actual position and stiffness of the supports. Small and/or flexible devices, such as cleats, intended to provide load compression of the packing material are not generally to be included in these calculations.

8.7.5 Only the active supporting and securing devices having an effective stiffness in the relevant direction are to be considered in the calculation of the reaction forces acting on the devices.

8.7.6 The number of securing and supporting devices is generally to be the minimum practicable whilst complying with *Pt 3, Ch 11, 8.5 Arrangements for the closing, securing and supporting of doors 8.5.3* and taking account of the available space in the hull for adequate support.

8.7.7 The arrangement of securing devices and supporting devices in way of these securing devices is to be designed with redundancy so that in the event of failure of any single securing or supporting device the remaining devices are capable of withstanding the reaction forces, without exceeding, by more than 20 per cent, the permissible stresses as defined in *Pt 3, Ch 11, 8.7 Design of securing and supporting devices 8.7.1*.

8.8 Operating and Maintenance Manual

8.8.1 An Operating and Maintenance Manual for the doors is to be provided on board and is to contain necessary information on:

- (a) main particulars and design drawings,
- (b) service conditions, e.g. service area restrictions, acceptable clearances for supports,
- (c) maintenance and function testing,
- (d) register of inspections, repairs and renewals.

8.8.2 For passenger/vehicle ferries and roll on-roll off cargo ships, see *Pt 4, Ch 2, 1.1 Application 1.1.1*, an Operating and Maintenance Manual for the doors, as defined in *Pt 4, Ch 2, 8.7 Operating and Maintenance Manual 8.7.1*, is to be provided on board instead of that required by *Pt 3, Ch 11, 8.8 Operating and Maintenance Manual 8.8.1*.

8.8.3 The Manual is to be submitted for approval, and is to contain a note recommending that recorded inspections of the door supporting and securing devices be carried out by the ship's staff at monthly intervals or following incidents that could result in damage, including heavy weather or contact in the region of the doors. Any damages recorded during such inspections are to be reported to LR.

8.8.4 Documented operating procedures for closing and securing the doors are to be kept on board and posted at an appropriate place.

■ Section 9

Watertight doors in bulkheads below the freeboard deck

9.1 Openings in bulkheads

9.1.1 Certain openings below the freeboard deck are permitted, but these must be kept to a minimum and provided with means of closing to watertight standards. All such openings are to be to the satisfaction of the Surveyor.

9.2 Watertight doors

9.2.1 Watertight doors are to be of equivalent strength to the unpierced bulkhead, efficiently constructed and fitted, and are to be capable of being closed watertight when the ship is listed up to 15° either way. They are to be operated under working conditions and hose tested in place, see *Table 1.9.1 Testing requirements* in Chapter 1.

9.2.2 The scantlings of the watertight doors are to comply with *Pt 4, Ch 1, 9 Bulkheads* using the actual stiffener spacing of the door.

9.2.3 The scantlings of the frames of the watertight doors are to satisfy the requirements of watertight bulkheads given in *Table 1.9.1 Watertight and deep tank bulkhead scantlings* in *Pt 4, Ch 1, 9 Bulkheads* taking into account the arrangement of door stiffeners and securing arrangements.

9.2.4 Watertight doors of the sliding type are to be capable of being operated both at the door itself and from an accessible position above the bulkhead deck. Means are to be provided at all the remote operating positions to indicate whether the door is open or closed. Doors are to be capable of being remotely closed by power from the bridge. The relevant regulations regarding openings in watertight bulkheads, contained in the *SOLAS - International Convention for the Safety of Life at Sea* and applicable amendments, are also to be complied with.

9.2.5 Hinged watertight doors of approved pattern may be fitted in 'tween decks in approved positions. The hinges of these doors are to be fitted with gunmetal pins or gunmetal bushes.

9.2.6 The frames of vertical watertight doors shall have no groove at the bottom in which dirt might lodge and prevent the door closing properly.

9.2.7 Means are to be provided on the navigating bridge to indicate whether the watertight doors are open or closed. A notice is to be affixed to both sides of each such door or hatch cover to the effect that it is not to be left open.

9.2.8 In passenger ships the number and construction of the watertight doors in bulkheads will be specially considered. Each watertight door is to be tested, see *Table 1.9.1 Testing requirements*. The test may be carried out either before or after the door is fitted. The relevant regulations regarding openings in watertight bulkheads in passenger ships, contained in the SOLAS - *International Convention for the Safety of Life at Sea* and applicable amendments, are also to be complied with.

■ Section 10

External openings and openings in watertight bulkheads and internal decks in cargo ships

10.1 Shell and watertight subdivision openings

10.1.1 In addition to the requirements of *Pt 3, Ch 11, 8 Side and stern doors and other shell openings* and *Pt 3, Ch 11, 9 Watertight doors in bulkheads below the freeboard deck*, for cargo ships of 80 m in length and above, the relevant regulations concerning shell and watertight subdivision openings contained in the SOLAS - *International Convention for the Safety of Life at Sea* 1974, and amendments thereto are also to be complied with.

Section

-
- 1 **General**
 - 2 **Ventilators**
 - 3 **Air and sounding pipes**
 - 4 **Scuppers and sanitary discharges**
 - 5 **Air pipes, ventilator pipes and their securing devices located on the exposed fore deck**
-

■ *Section 1*
General

1.1 Application

1.1.1 This Chapter applies to all ship types detailed in *Pt 4 Ship Structures (Ship Types)*, and provides requirements for ventilators, air and sounding pipes and overboard discharges.

1.1.2 The requirements conform, where relevant, with those of the *Load Lines, 1966/1988 - International Convention on Load Lines, 1966, as Amended by the Protocol of 1988* Reference should also be made to any additional requirements of the National Authority of the country in which the ship is to be registered and to the relevant regulations of the *SOLAS - International Convention for the Safety of Life at Sea* and applicable amendments.

1.2 Protection

1.2.1 In all cargo spaces and other areas where mechanical damage is likely, all air and sounding pipes, scuppers and discharges, including their valves, controls and indicators, are to be well protected. This protection is to be of steel or other equivalent material.

■ *Section 2*
Ventilators

2.1 General

2.1.1 Ventilators located on the exposed deck over the forward 0,25L of the rule length, of ships of sea-going service of length 80 m or more, where the height of the exposed deck in way of the item is less than 0,1L or 22 m above the summer load waterline, whichever is the lesser, are to comply with the requirements of *Pt 3, Ch 12, 5 Air pipes, ventilator pipes and their securing devices located on the exposed fore deck*. All other ventilators are to comply with the following requirements.

2.1.2 Special care is to be taken in the design and positioning of ventilator openings and coamings, particularly in the region of the forward end of superstructures and other points of high stress. The deck plating in way of the coamings is to be efficiently stiffened.

2.1.3 Ventilators from deep tanks and tunnels passing through 'tween decks are to have scantlings suitable for withstanding the pressures to which they may be subjected, and are to be made watertight.

2.1.4 For height and location of cargo tank vent outlets, see *Pt 5, Ch 15, 4 Cargo tank venting, purging and gas-freeing* and see also *Ch 8, 8.2.9 and 8.2.10 of the Rules for the Construction and Classification of Ships for the Carriage of Liquefied Gases in Bulk* (hereinafter referred to as the Rules for Ships for liquefied Gases), or *Ch 1, 8.2 Cargo tank venting 8.2.2, of the Rules for the Construction and Classification of Ships for the Carriage of Liquid Chemicals in Bulk* (hereinafter referred to as the Rules for Ships for Liquid Chemicals), where applicable.

2.2 Coamings

2.2.1 The scantlings and height of ventilator coamings exposed to the weather are to be not less than required by *Table 12.2.1 Ventilator coaming requirements* but the thickness need not exceed that of the adjacent deck or bulkhead plating. In particularly exposed positions, the height of coamings and scantlings may be required to be increased.

Table 12.2.1 Ventilator coaming requirements

Feature	Requirements
Height (measured above sheathing if fitted)	(1) $z_c = 900$ mm at Position 1 (see Pt 3, Ch 1, 6.5 Position 1 and Position 2)
	$z_c = 760$ mm at Position 2 (see Pt 3, Ch 1, 6.5 Position 1 and Position 2)
Thickness	(2) $t_c = 5,5 + 0,01 \delta_v$ mm where $7,5 \text{ mm} \leq t_c \leq 10,0 \text{ mm}$
Support	(3) If $z_c > 900$ mm the coaming is to be specially supported
Symbols	
t_c = thickness of coaming, in mm	
z_c = height of coaming, in mm	
δ_v = internal diameter of coaming, in mm	
NOTE Where the height of the ventilator exceeds that given in Item (1), the thickness given by (2) may be generally reduced, above that height, to a minimum of 6,5 mm. The ventilator is to be adequately stayed.	

2.2.2 The height of ventilator coamings may be required to be increased on ships of Type 'A', Type 'B-100' and Type 'B-60' where this is shown to be necessary by the floatability calculations required by the *Load Lines, 1966/1988 - International Convention on Load Lines, 1966, as Amended by the Protocol of 1988*

2.2.3 For gooseneck ventilators, the coaming height is to be measured to the underside of the bend, this being the lowest point through which water on deck could pass freely to spaces below.

2.2.4 Where wall vents are fitted with an internal baffle which rises above the lower edge of the exterior opening, the coaming height is measured to the top of the baffle.

2.2.5 Where permitted by the National Authority, ventilator coaming heights may be reduced on ships engaged on protected or extended protected water service. Coaming heights are to be as high as practicable, with a minimum height of 450 mm in Position 1 and 300 mm in Position 2.

2.3 Closing appliances

2.3.1 All ventilator openings are to be provided with efficient weathertight closing appliances of steel or other equivalent material unless:

- the height of the coaming is greater than 4,5 m where *Table 12.2.1 Ventilator coaming requirements* requires a minimum height of 900 mm; or
- the height of the coaming is greater than 2,3 m where *Table 12.2.1 Ventilator coaming requirements* requires a minimum height of 760 mm.

2.3.2 In ships where the load line length, L_L (see Pt 3, Ch 1, 6.1 *Principal particulars*), is not more than 100 m, the closing appliances are to be permanently attached to the ventilator coaming. Where not so provided in other ships, they are to be conveniently stowed near the ventilator to which they are to be fitted.

2.3.3 Where, in ferries, ventilators are proposed to be led overboard in an enclosed 'tween deck, the closing arrangements are to be submitted for approval. If such ventilators are led overboard more than 4,5 m above the main vehicle deck, closing

appliances may be omitted, provided that satisfactory baffles and drainage arrangements are provided, as in the case of air intakes or exhaust openings for machinery spaces, which may be arranged in the sides of the ship.

2.3.4 On offshore supply ships, to ensure satisfactory operation in all weather conditions, machinery space ventilation inlets and outlets are to be located in such positions that closing appliances will not be necessary.

2.3.5 Mushroom ventilators closed by a head revolving on a centre spindle (screw down head) are acceptable in Position 2, and also in sheltered positions in Position 1, excluding those described in *Pt 3, Ch 12, 2.1 General 2.1.1*, but the diameter is not to exceed 300 mm if situated within the forward 0,25L_L.

2.3.6 Mushroom ventilators with a fixed head and closed by a screw down plate (screw down cover) may be accepted in exposed positions within the forward 0,25L_L, excluding those described in *Pt 3, Ch 12, 2.3 Closing appliances 2.3.6*, up to a diameter of 750 mm.

2.3.7 Wall ventilators (jalousies) may be accepted provided they are capable of being closed weathertight by hinged steel gasketed covers secured by bolts or toggles.

2.3.8 A ventilator head not forming part of the closing arrangements is to be not less than 6,5 mm thick.

2.3.9 In order to limit the fire growth potential in every space of the ship, the main inlets and outlets of all ventilation systems shall be capable of being closed from outside the spaces being ventilated. The means of closing shall be easily accessible as well as prominently and permanently marked and shall indicate whether the inlet or outlet is open or closed. Battery room ventilators are only to be fitted with a means of closing, whenever:

- (a) the battery room does not open directly on to an exposed deck; or
- (b) the ventilation opening for the battery room is required to be fitted with a closing device according to the Load Line Convention; or
- (c) the battery room is fitted with a fixed gas fire extinguishing system.

Where a battery room ventilator is fitted with a closing device see *Pt 6, Ch 2, 12.5 Ventilation 12.5.2*.

2.4 Machinery spaces

2.4.1 In general, ventilators necessary to continuously supply the machinery space are to have coamings of sufficient height to comply with *Pt 3, Ch 12, 2.3 Closing appliances 2.3.1* without having to fit weathertight closing appliances. Ventilators to emergency generator rooms are to be so positioned that closing appliances are not required.

2.4.2 Where due to ship size and arrangement this is not practicable, lesser heights for machinery space ventilator coamings fitted with weathertight closing appliances may be permitted by the administration in combination with other suitable arrangements to ensure uninterrupted, adequate supply of ventilation to these spaces.

■ Section 3 Air and sounding pipes

3.1 General

3.1.1 Air pipes located on the exposed deck over the forward 0,25L of the rule length, of ships of sea-going service of length 80 m or more, where the height of the exposed deck in way of the item is less than 0,1L or 22 m above the summer load waterline, whichever is the lesser, are to comply with the requirements of Section 5. All other air and sounding pipes are to comply with the following requirements in addition to the applicable requirements of *Pt 5, Ch 13, 12 Air, overflow and sounding pipes* and *Pt 5, Ch 15, 2 Piping systems for bilge, ballast, fuel oil, etc.*

3.1.2 Striking plates of suitable thickness, or their equivalent, are to be fitted under all sounding pipes.

3.1.3 On offshore supply ships, air pipes are to be situated clear of the cargo containment areas.

3.2 Height of air pipes

3.2.1 The height of air pipes from the upper surface of decks exposed to the weather, to the point where water may have access below, is normally to be not less than:

- 760 mm on the freeboard deck;

- 450 mm on the superstructure deck;

these heights being measured above deck sheathing, where fitted.

3.2.2 Lower heights may be approved in cases where these are essential for the working of the ship, provided that the design and arrangements are otherwise satisfactory. In such cases, efficient, permanently attached closing appliances of an approved automatic type will generally be required.

3.2.3 The height of air pipes may be required to be increased on ships of Type 'A', Type 'B-100' and Type 'B-60' where this is shown to be necessary by the floatability calculations required by the *International Convention on Load Lines, 1966*. An increase in height may also be required or recommended by individual Administrations when air pipes to fuel oil and settling tanks are situated in positions where sea water could be temporarily entrapped, e.g. in recesses in the sides and ends of superstructures or deckhouses, between hatch ends, behind high sections of bulwark, etc. This may entail an increase in tank scantlings, see also Pt 3, Ch 3 *Structural Design*.

3.2.4 Air pipes are generally to be led to an exposed deck. For alternative arrangements in an enclosed space on a main vehicle deck, see Pt 4, Ch 2, 9 *Subdivision structure on vehicle deck*.

3.2.5 Where air pipes are led through the side of superstructures, the opening is to be at least 2,3 m above the summer load waterline.

3.2.6 The minimum wall thickness of air pipes in positions indicated in Pt 3, Ch 12, 3.2 *Height of air pipes* 3.2.1 is to be:

- 6,0 mm for pipes of 80 mm external diameter or smaller;
- 8,5 mm for pipes of 165 mm external diameter or greater.

Intermediate minimum thicknesses are to be determined by linear interpolation.

3.2.7 Where permitted by the National Authority, air pipe coaming heights may be reduced on ships engaged on protected or extended protected water service. Coaming heights are to be as high as practicable, with a minimum height of 450 mm on the freeboard deck and 300 mm on a superstructure deck.

3.3 Closing appliances

3.3.1 All openings of air and sounding pipes are to be provided with permanently attached, satisfactory means of closing to prevent the free entry of water, see also Pt 3, Ch 12, 3.2 *Height of air pipes* 3.2.2.

3.3.2 Closing appliances are to be of an approved automatic type.

3.3.3 Pressure/vacuum valves as required by Pt 5, Ch 15, 4 *Cargo tank venting, purging and gas-freeing* may be accepted as closing appliances for cargo tanks.

■ Section 4 **Scuppers and sanitary discharges**

4.1 General

4.1.1 Scuppers sufficient in number and size to provide effective drainage are to be fitted in all decks.

4.1.2 Scuppers draining weather decks and spaces within superstructures or deckhouses not fitted with efficient weathertight doors are to be led overboard.

4.1.3 Where the freeboard is such that the freeboard deck edge is immersed when the ship heels 5° or less, scuppers and discharges which drain spaces below the freeboard deck, or spaces within intact superstructures or deckhouses on the freeboard deck fitted with efficient weathertight doors, are to be led to the bilges in the case of scuppers or to suitable sanitary tanks in the case of sanitary discharges. Where the freeboard is such that the freeboard deck edge is immersed when the ship heels greater than 5° then they may be led overboard and fitted with means of preventing water from passing inboard in accordance with Pt 3, Ch 12, 4.2 *Closing appliances*.

4.1.4 In ships where an approved fixed pressure water spray fire-extinguishing system is fitted in vehicle or cargo spaces, deck scuppers of not less than 150 mm diameter are to be provided port and starboard, spaced about 9,0 m apart. The scupper area will require to be increased if the design capacity of the drencher system exceeds the Rule required capacity by 10 per cent or more. After installation, the two adjacent sections with the greatest aggregate drencher capacity are to be tested in operation to

ensure that there is no build up of water on the deck, see also *Pt 4, Ch 2, 11.2 Openings in main vehicle deck 11.2.2*. The mouth of the scupper is to be protected by bars.

4.1.5 Where a sewage system is fitted, the shipside valves on the discharge pipe from the effluent tank(s) and the by-pass system are to comply with *Pt 3, Ch 12, 4.2 Closing appliances*.

4.1.6 The minimum wall thickness of pipes not indicated in *Pt 3, Ch 12, 4.2 Closing appliances 4.2.6* is to be:

- 4,5 mm for pipes of 155 mm external diameter or smaller.
- 6,0 mm for pipes of 230 mm external diameter or greater.

Intermediate minimum thicknesses are to be determined by linear interpolation.

4.1.7 For the use of non-metallic pipe, see *Pt 5, Ch 12, 5 Plastics pipes*.

4.1.8 Scuppers and discharge pipes should not normally pass through fuel oil or cargo oil tanks. Where scuppers and discharge pipes pass, unavoidably, through fuel oil or cargo oil tanks, and are led through the shell within the tanks, the thickness of the piping should be at least the same thickness as Rule shell plating in way, derived from the appropriate Chapters, but need not exceed 19 mm.

4.1.9 Piping within tanks is to be tested in accordance with *Pt 3, Ch 1, 8 Inspection and workmanship*.

4.1.10 All piping is to be adequately supported.

4.1.11 See also the *18 Rules and Regulations for the Construction and Classification of Ships for the Carriage of Liquefied Gases in Bulk, July 2015* or the *Rules and Regulations for the Construction and Classification of Ships for the Carriage of Liquid Chemicals in Bulk, July 2015*, where applicable.

4.1.12 For additional requirements for scuppers and sanitary discharges on dredging and reclamation craft, see *Pt 4, Ch 12, 15 Spoil space weirs and overflows*.

4.2 Closing appliances

4.2.1 In general, each separate overboard discharge is to be fitted with a screw-down non-return valve capable of being operated from a position always accessible and above the freeboard deck. An indicator is to be fitted at the control position showing whether the valve is open or closed. A machinery space, whether manned or unattended (i.e. with **UMS** notation), is considered accessible. Cargo holds or spaces with access only by hatches or bolted manholes are not considered accessible.

4.2.2 Where a drencher fire-extinguishing system is provided in an enclosed vehicle space of a ferry, the scupper controls are to be operated from a position above the bulkhead deck, and outside the vehicle space protected by the drencher system, and are to be protected from mechanical damage.

4.2.3 Where the vertical distance from the summer load waterline to the inboard end of the discharge pipe exceeds $0,01L_{\perp}$ the discharge may be fitted with two automatic non-return valves without positive means of closing, instead of the screw-down non-return valve, provided that the inboard valve is always accessible for examination under service conditions.

4.2.4 Where the vertical distance from the summer load waterline to the inboard end of the discharge pipe exceeds $0,02L_{\perp}$, a single automatic non-return valve without positive means of closing may be fitted, see *Figure 12.4.1 Diagrammatic arrangement of discharge valves*.

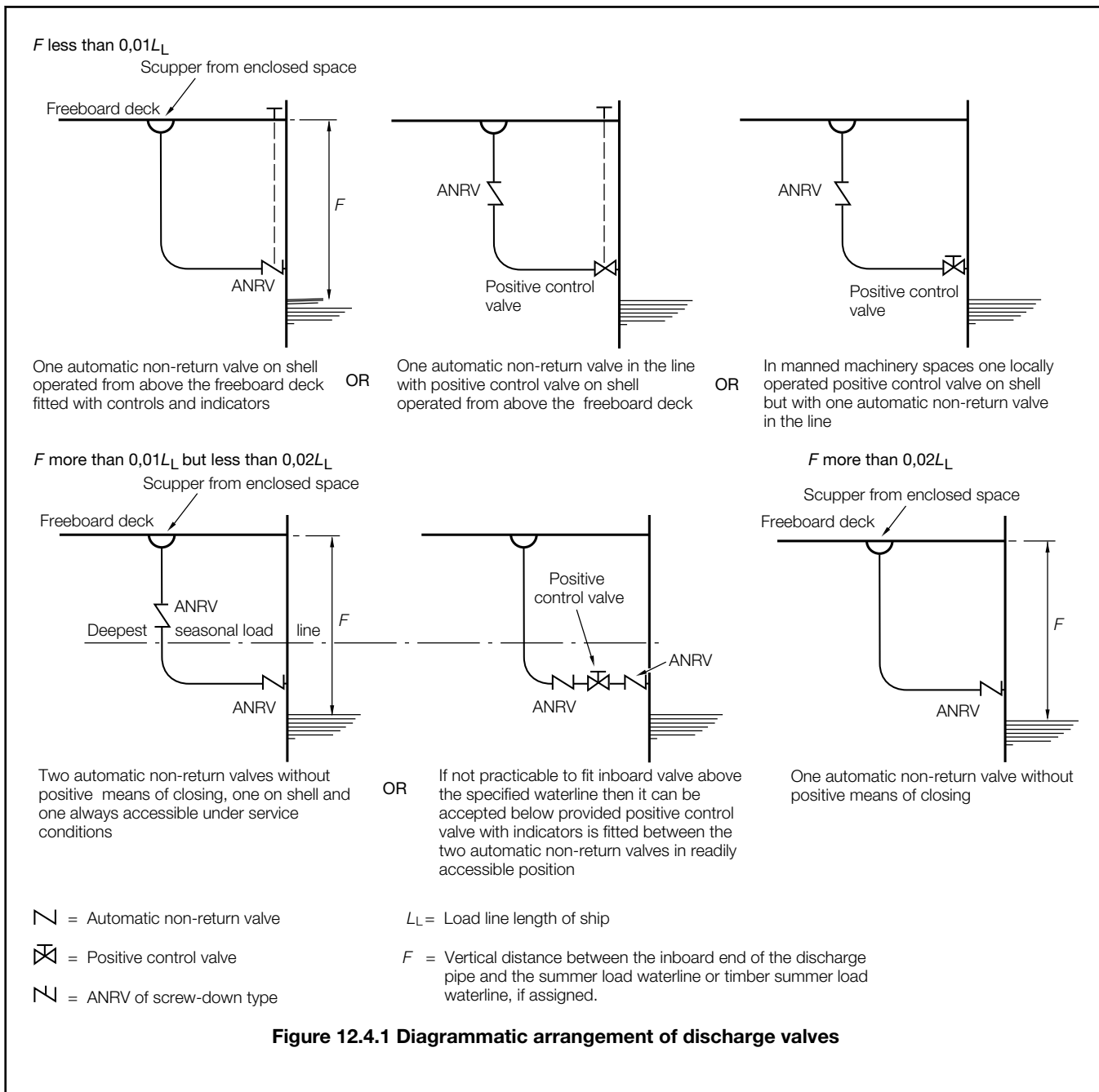

4.2.5 The requirements for non-return valves are applicable only to those discharges which remain open during the normal operation of the ship. For discharges which are closed at sea, such as gravity drains from topside ballast tanks, a single screw down valve operated from the freeboard deck is considered to provide sufficient protection.

4.2.6 Scuppers and discharge pipes originating at any level which penetrate the shell either more than 450 mm below the freeboard deck or less than 600 mm above the summer load waterline, are to be fitted with an automatic non-return valve at the shell. This valve, unless required by Pt 3, Ch 12, 4.1 General 4.1.3, may be omitted provided the piping has a minimum wall thickness of:

- 7,0 mm for pipes of 80 mm external diameter or smaller;
- 10,0 mm for pipes of 180 mm external diameter;
- 12,5 mm for pipes of 220 mm external diameter or greater.

Intermediate minimum thicknesses are to be determined by linear interpolation. Unless required by Pt 3, Ch 12, 4.1 General 4.1.8, the maximum thickness need not exceed 12,5 mm.

4.2.7 The outboard valve is to be mounted directly on the shell and secured in accordance with *Pt 5, Ch 13, 2.5 Ship-side valves and fittings (other than those on scuppers and sanitary discharges) 2.5.1*. If this is impracticable, a short distance piece of rigid construction may be introduced between the valve and the shell. Valves should not be fitted in cargo tanks.

4.2.8 If a valve is required by *Pt 3, Ch 12, 4.1 General 4.1.3*, this valve should preferably be fitted as close as possible to the point of entry of the pipe into the tank. If fitted below the freeboard deck, the valve is to be capable of being controlled from an easily accessible position above the freeboard deck. Local control is also to be arranged, unless the valve is inaccessible. An indicator is to be fitted at the control position showing whether the valve is open or closed.

4.2.9 In a ship to which timber freeboards are assigned, the summer load waterline is to be regarded as that corresponding to the timber summer freeboard.

4.2.10 For ship side valves and fittings (other than those on scuppers and sanitary discharges), see *Pt 5, Ch 13, 2 Construction and installation* and *Pt 6, Ch 1, 2 Essential features for control, alarm and safety systems*.

4.3 Rubbish chutes, offal and similar discharges

4.3.1 Rubbish chutes, offal and similar discharges should be constructed of mild steel piping or plating of shell thickness. Other materials will be specially considered. Openings are to be kept clear of the sheerstrake and areas of high stress concentration.

4.3.2 Rubbish chute hoppers are to be provided with a hinged weathertight cover at the inboard end with an interlock so that the discharge flap and hopper cover cannot be open at the same time. The hopper cover is to be secured closed when not in use, and a suitable notice displayed at the control position.

4.3.3 Where the inboard end of the hopper is less than $0,01L_L$ above the summer load waterline, a suitable valve with positive means for closing is to be provided in addition to the cover and flap in an easily accessible position above the deepest seasonal waterline. The valve is to be controlled from a position adjacent to the hopper and provided with an open/shut indicator. The valve is to be kept closed when not in use, and a suitable notice displayed at the valve operating position.

4.3.4 Where damage stability requirements apply and the inboard end of the chute is below the equilibrium waterlines, or in passenger ships, where the inboard end of a rubbish chute is below the margin line; see *Pt 3, Ch 11, 8.2 General 8.2.8*.

4.3.5 In trawlers or fish factory ships, offal discharges in the fish working spaces are to be provided with either a non-return flap, preferably fitted at the shell which can be positively secured weathertight, or a separate positively controlled valve kept closed when not in use. A suitable notice is to be displayed at the flap or valve operating position.

4.4 Materials for valves, fittings and pipes

4.4.1 All shell fittings and valves required by *Pt 3, Ch 12, 4.2 Closing appliances* are to be of steel, bronze or other approved ductile material; ordinary cast iron or similar material is not acceptable. Materials are to satisfy the requirements of the *Rules for the Manufacture, Testing and Certification of Materials, July 2015*.

4.4.2 All these items, if made of steel or other approved material with low corrosion resistance, are to be suitably protected against wastage.

4.4.3 The lengths of pipe attached to the shell fittings, elbow pieces or valves are to be of galvanised steel or other equivalent approved material.

■ Section 5 **Air pipes, ventilator pipes and their securing devices located on the exposed fore deck**

5.1 General

5.1.1 For the application of the following requirements relating to ventilators, see *Pt 3, Ch 12, 2.1 General 2.1.1*. For the application of the following requirements relating to air pipes, see *Pt 3, Ch 12, 3.1 General 3.1.1*. Air pipes complying with the following requirements are also to comply with the applicable requirements of *Pt 5, Ch 13, 12 Air, overflow and sounding pipes* and *Pt 5, Ch 15, 2.5 Air and sounding pipes*.

5.1.2 Special care is to be taken in the design and positioning of ventilator openings and coamings, particularly in the region of the forward end of superstructures and other points of high stress. The deck plating in way of the coamings is to be efficiently stiffened.

5.1.3 Ventilators from deep tanks and tunnels passing through 'tween decks are to have scantlings suitable for withstanding the pressures to which they may be subjected, and are to be made watertight.

5.1.4 For height and location of cargo tank vent outlets, see *Pt 5, Ch 15, 4 Cargo tank venting, purging and gas-freeing* and see also *Ch 8,8.2.9* and *8.2.10* of the Rules for Ships for Liquefied Gases, or *Ch 1, 8.2 Cargo tank venting 8.2.2*, of the Rules for Ships for Liquid Chemicals, where applicable.

5.1.5 On offshore supply ships, air pipes are to be situated clear of the cargo containment areas.

5.2 Loading

5.2.1 The design pressure acting on air pipes, ventilator pipes and their closing devices is to be taken as not less than:

$$p = 0,5 \rho V^2 C_d C_s C_p \text{ kN/m}^2$$

where

ρ = density of sea water (1,025 t/m³)

V = velocity of water over the fore deck

= 13,5 m/sec for $d \leq 0,5d_1$

= $13,5 \sqrt{2 \left(1 - \frac{d}{d_1}\right)}$ for $d > 0,5d_1$

d = distance from summer load waterline to exposed deck

d_1 = 0,1L but need not be taken as greater than 22 m

C_d = shape coefficient (0,5 for pipes, 1,3 for air pipe or ventilator heads in general and 0,8 for an air pipe or ventilator head of cylindrical form with its axis in the vertical direction)

C_s = slamming coefficient (3,2)

C_p = protection coefficient (0,7 for pipes and ventilator heads located immediately behind a breakwater or forecastle and 1,0 elsewhere and immediately behind a bulwark).

5.2.2 Forces acting in the horizontal direction on the pipe and its closing device are to be not less than those calculated from *Pt 3, Ch 12, 5.2 Loading 5.2.1* using the largest projected area of each component.

5.3 Strength requirements

5.3.1 Bending moments and stresses in air and ventilator pipes are to be calculated at critical positions:

- at penetration pieces;
- at weld or flange connections; and
- at toes of supporting brackets.

5.3.2 Bending stresses in the net section are not to exceed $0,8\sigma_y$, where σ_y is the specified minimum yield stress or 0,2 per cent proof stress of the steel at room temperature. Irrespective of corrosion protection, a corrosion addition to the net section of 2,0 mm is then to be applied.

5.3.3 For standard air pipes of 760 mm coaming height closed by heads of not more than the tabulated projected area, pipe thicknesses and bracket heights are specified in *Table 12.5.1 Air pipe thickness and bracket standards*. Where brackets are required, three or more radial brackets are to be fitted. Brackets are to be of gross thickness 8 mm or more, of minimum length 100 mm, and height according to *Table 12.5.1 Air pipe thickness and bracket standards* but need not extend over the joint flange for the head. Bracket toes at the deck are to be suitably supported.

Table 12.5.1 Air pipe thickness and bracket standards

Nominal pipe diameter, in mm	Minimum fitted gross thickness, in mm	Maximum projected area of head, in cm ²	Height ⁽¹⁾ of brackets, in mm
65A	6,0	-	480
80A	6,3	-	460
100A	7,0	-	380
125A	7,8	-	300
150A	8,5	-	300
175A	8,5	-	300
200A	8,5 ⁽²⁾	1900	300 ⁽²⁾
250A	8,5 ⁽²⁾	2500	300 ⁽²⁾
300A	8,5 ⁽²⁾	3200	300 ⁽²⁾
350A	8,5 ⁽²⁾	3800	300 ⁽²⁾
400A	8,5 ⁽²⁾	4500	300 ⁽²⁾
(1)	Brackets (see Pt 3, Ch 12, 5.3 Strength requirements 5.3.3) need not extend over the joint flange for the head.		
(2)	Brackets are required where the as fitted (gross) thickness is less than 10,5mm, or where the tabulated projected head area is exceeded.		
Note For other pipe heights, the relevant requirements of Pt 3, Ch 12, 5.3 Strength requirements are to be applied.			

5.3.4 For other configurations, loads according to Pt 3, Ch 12, 5.2 Loading are to be applied, and means of support determined in order to comply with the requirements of Pt 3, Ch 12, 5.3 Strength requirements 5.3.1 and Pt 3, Ch 12, 5.3 Strength requirements 5.3.2. Brackets, where fitted, are to be of suitable thickness and length according to their height. Pipe thickness is not to be taken less than as indicated in Pt 5, Ch 12 Piping Design Requirements.

Table 12.5.2 900 mm Ventilator pipe thickness and bracket standards

Nominal pipe diameter, in mm	Minimum fitted gross thickness, in mm	Maximum projected area of head, in cm ²	Height of brackets, in mm
80A	6,3	-	460
100A	7,0	-	380
150A	8,5	-	300
200A	8,5	550	-
250A	8,5	880	-
300A	8,5	1200	-
350A	8,5	2000	-
400A	8,5	2700	-
450A	8,5	3300	-

500A	8,5	4000	-
Note For ventilator heights other than 900 mm, the relevant requirements of 5.3 are to be applied.			

5.3.5 For standard ventilators of 900 mm coaming height closed by heads of not more than the tabulated projected area, pipe thicknesses and bracket heights are specified in *Table 12.5.2 900 mm Ventilator pipe thickness and bracket standards*. Brackets, where required, are to be as specified in *Pt 3, Ch 12, 5.3 Strength requirements 5.3.3*.

5.3.6 For ventilators of coaming height greater than 900 mm, the coaming support will be specially considered. Pipe thickness is not to be taken less than as indicated in *Pt 5, Ch 12 Piping Design Requirements*.

5.3.7 All component parts and connections of the air pipe or ventilator are to be capable of withstanding the loads defined in *Pt 3, Ch 12, 5.2 Loading*.

5.4 Ventilator coamings

5.4.1 The height of ventilator coamings is to be not less than 900 mm, this height being measured above deck sheathing, where fitted. In particularly exposed positions, the heights of coamings and scantlings may be required to be increased.

5.4.2 The height of ventilator coamings may be required to be increased on ships of Type 'A', Type 'B-100' and Type 'B-60' where this is shown to be necessary by the floatability calculations required by the *Load Lines, 1966/1988 - International Convention on Load Lines, 1966, as Amended by the Protocol of 1988*.

5.4.3 For gooseneck ventilators, the coaming height is to be measured to the underside of the bend, this being the lowest point through which water on deck could pass freely to spaces below.

5.4.4 Where wall vents are fitted with an internal baffle which rises above the lower edge of the exterior opening, the coaming height is measured to the top of the baffle.

5.4.5 Where permitted by the National Authority, ventilator coaming heights may be reduced on ships engaged on protected or extended protected water service. Coaming heights are to be as high as practicable, with a minimum height of 450 mm.

5.5 Height of air pipes

5.5.1 The height of air pipes from the upper surface of decks exposed to the weather, to the point where water may have access below is normally to be not less than 760 mm, this height being measured above deck sheathing, where fitted.

5.5.2 Lower heights may be approved in cases where these are essential for the working of the ship, provided that the design and arrangements are otherwise satisfactory. In such cases, efficient, permanently attached closing appliances of an approved automatic type will generally be required.

5.5.3 The height of air pipes may be required to be increased on ships of Type 'A', Type 'B-100' and Type 'B-60' where this is shown to be necessary by the floatability calculations required by the *Load Lines, 1966/1988 - International Convention on Load Lines, 1966, as Amended by the Protocol of 1988*. An increase in height may also be required or recommended by individual Administrations when air pipes to fuel oil and settling tanks are situated in positions where sea-water could be temporarily entrapped, e.g. in recesses in the sides and ends of superstructures or deckhouses, between hatch ends, behind high sections of bulwark, etc. This may entail an increase in tank scantlings, see also *Pt 3, Ch 3 Structural Design*.

5.5.4 Air pipes are generally to be led to an exposed deck. For alternative arrangements in an enclosed space on a main vehicle deck, see *Pt 4, Ch 2, 9 Subdivision structure on vehicle deck*.

5.5.5 Where air pipes are led through the side of superstructures, the opening is to be at least 2,3 m above the summer load waterline.

5.5.6 Where permitted by the National Authority, air pipe coaming heights may be reduced on ships engaged on protected or extended protected water service. Coaming heights are to be as high as practicable, with a minimum height of 450 mm.

5.6 Closing appliances for ventilators

5.6.1 All ventilator openings are to be provided with efficient weathertight closing appliances unless the height of the coaming is greater than 4,5 m.

5.6.2 In ships where the load line length, L_L (see *Pt 3, Ch 1, 6.1 Principal particulars*), is not more than 100 m, the closing appliances are to be permanently attached to the ventilator coaming. Where not so provided in other ships, they are to be conveniently stowed near the ventilator to which they are to be fitted.

5.6.3 Where, in ferries, ventilators are proposed to be led overboard in an enclosed 'tween deck, the closing arrangements are to be submitted for approval. If such ventilators are led overboard more than 4,5 m above the main vehicle deck, closing appliances may be omitted, provided that satisfactory baffles and drainage arrangements are provided, as in the case of air intakes or exhaust openings for machinery spaces, which may be arranged in the sides of the ship.

5.6.4 On offshore supply ships, to ensure satisfactory operation in all weather conditions, machinery space ventilation inlets and outlets are to be located in such positions that closing appliances will not be necessary.

5.6.5 Rotating type mushroom ventilator heads are unsuitable for application on the exposed fore deck.

5.6.6 Wall ventilators (jalousies) may be accepted provided they are capable of being closed weathertight by hinged steel gasketed covers secured by bolts or toggles.

5.6.7 A ventilator head not forming part of the closing arrangements is to be not less than 6,5 mm thick.

5.7 Closing appliances for air pipes

5.7.1 All openings of air pipes are to be provided with permanently attached, satisfactory means of closing to prevent the free entry of water, *see also Pt 3, Ch 12, 5.5 Height of air pipes 5.5.2.*

5.7.2 Closing appliances are to be of an approved automatic type where, with the ship at its summer load waterline, the openings are immersed at an angle of heel of 40° or, the angle of down flooding if this is less than 40°. *see also Pt 3, Ch 3, 6 Minimum bow heights, reserve buoyancy and extent of forecastle.*

5.7.3 Where the closing appliances are not of an automatic type, provision is to be made for relieving vacuum when the tanks are being pumped out.

5.7.4 In a ship to which timber freeboards are assigned, air pipes which will be inaccessible when the deck cargo is carried are to be provided with approved automatic closing appliances.

5.7.5 Pressure/vacuum valves as required by *Pt 5, Ch 15, 4 Cargo tank venting, purging and gas-freeing* may be accepted as closing appliances for cargo tanks.

Section

- 1 **General**
- 2 **Rudders**
- 3 **Fixed and steering nozzles**
- 4 **Steering gear and allied systems**
- 5 **Bow and stern thrust unit structure**
- 6 **Stabiliser structure**
- 7 **Equipment**
- 8 **Windlass design and testing**
- 9 **Mooring of ships at single point moorings**
- 10 **Emergency towing arrangements**

■ Section 1 General

1.1 Application

1.1.1 This Chapter applies to all the ship types detailed in *Pt 4 Ship Structures (Ship Types)*, and requirements are given for rudders, nozzles, steering gear, bow and stern thrust unit structure, stabiliser structure, anchoring and mooring equipment, and emergency towing arrangements.

1.1.2 The requirements in this Chapter are not applicable to Double Hull Oil Tankers or Bulk Carriers with a **CSR** notation (see *Pt 1, Ch 2, 2.3 Class notations (hull)*) with the exception of the following:

- For Double Hull Tankers; Sections *Pt 3, Ch 13, 2 Rudders* to *Pt 3, Ch 13, 6 Stabiliser structure* are to be complied with as applicable.
- For Bulk Carriers; Sections *Pt 3, Ch 13, 3 Fixed and steering nozzles* to *Pt 3, Ch 13, 6 Stabiliser structure* and Section *Pt 3, Ch 13, 10 Emergency towing arrangements* are to be complied with as applicable.

1.2 General symbols

1.2.1 The following symbols and definitions are applicable to this Chapter, unless otherwise stated:

L , B and C_b as defined in *Pt 3, Ch 1, 6.1 Principal particulars*

σ_0 = minimum yield stress or 0,5 per cent proof stress of the material, in $N/mm^2(kgf/mm^2)$

k = higher tensile steel factor, see *Pt 3, Ch 2, 1.2 Steel*.

1.3 Navigation in ice

1.3.1 Where an ice class notation is included in the class of a ship, additional requirements are applicable as detailed in *Pt 8 Rules for Ice and Cold Operations*.

1.4 Poddled propulsion

1.4.1 Where podded propulsion is included in the class of a ship, additional requirements as detailed in *Pt 5, Ch 9 Poddled Propulsion Units* are to be complied with, as applicable.

1.5 Materials

1.5.1 The requirements for materials are contained in the *Rules for the Manufacture, Testing and Certification of Materials, July 2015* (hereinafter referred to as the Rules for Materials).

1.5.2 Stern frames, rudder horns, shaft brackets, rudder stocks, pintles, coupling bolts, keys, and other rudder members are to be made of rolled, forged or cast carbon-manganese steel in accordance with *Ch 3 Rolled Steel Plates, Strip, Sections and Bars, Ch 4 Steel Castings* and *Ch 5 Steel Forgings* of the Rules for Materials. Cast steel stern frames, rudder horns, shaft brackets and sole pieces are to be manufactured from special grade material as specified in *Ch 4, 2 Castings for ship and other structural applications* of the Rules for Materials.

■ Section 2 Rudders

2.1 Design considerations

2.1.1 Effective means are to be provided for supporting the weight of the rudder without excessive bearing pressure, e.g. by a rudder carrier attached to the upper part of the rudder stock. The hull structure in way of the rudder carrier is to be suitably strengthened.

2.1.2 Suitable arrangements are to be provided to prevent the rudder from lifting.

2.1.3 In rudder trunks which are open to the sea, a seal or stuffing box is to be fitted above the deepest load waterline, to prevent water from entering the steering gear compartment and the lubricant from being washed away from the rudder carrier. If the top of the rudder trunk is below the deepest waterline, two separate stuffing boxes are to be provided. Rudder trunk boundaries, where exposed to the sea, are to have a corrosion protection coating applied in accordance with the manufacturer's instructions.

2.2 Lateral force on rudder blade

2.2.1 The lateral rudder force at the centre of pressure is to be determined for both ahead and astern conditions from the following formula:

$$P_L = 132 c_1 c_2 c_3 C_{TH} A_R V^2 N$$

where

A_R = rudder blade area, in m²

A_T = sum of rudder blade area A_R and area of rudder post or rudder horn, if any, within the rudder mean height h_R , in m²

c_1 = factor depending on the aspect ratio λ of the rudder area
 $= \frac{\lambda + 2}{3}$

c_2 = rudder profile coefficient, see *Table 13.2.1 Rudder profile coefficient, c2*

c_3 = 1,0 in general

= 0,8 for rudders outside the propeller jet

= 1,15 for rudders behind a fixed propeller nozzle

C_{TH} = thrust coefficient, is generally to be taken as 1

P_L = lateral force acting on the rudder, in N, is to be calculated for both ahead and astern conditions. The greater of these two values are to be used throughout Section 2

V = maximum service speed, in knots, which the ship is designed to maintain, at the summer load waterline. Maximum ahead service speed means the maximum service speed which the ship is designed to maintain, at the summer load waterline at maximum propeller RPM and corresponding engine MCR.

where

When the speed is less than 10 knots, V is to be replaced by the expression $V_{\min} = \frac{V + 20}{3}$. For the astern condition the actual astern speed, in knots, or $0,5V$, whichever is the greater is to be used (for bow rudders $V = V_A$)

$$\lambda = \frac{h_R^2}{A_T}, \text{ but not to be taken greater than } 2$$

h_R = mean height, in metres, of the rudder area, see *Figure 13.2.2 Rudder co-ordinate system*.

2.3 Rudder torque calculation for rudders without cut-outs

2.3.1 The rudder torque, M_T , is to be determined for both the ahead and astern conditions according to the following formula:

$$M_T = P_L \times x_p \text{ Nm}$$

where

P_L = lateral force acting on rudder, as calculated in *Pt 3, Ch 13, 2.2 Lateral force on rudder blade*

x_p = $b_R (\alpha - k)$, in metres, but not less than $0,1b_R$

M_T = the rudder torque, in Nm, to be calculated for both ahead and astern conditions. The greater of these two values are to be used throughout *Pt 3, Ch 13, 2 Rudders*

b_R = mean breadth of rudder, in metres, see *Figure 13.2.2 Rudder co-ordinate system*

α = as given in *Table 13.2.2 Coefficient, α*

$$k = \frac{A_f}{A_R}$$

A_f = portion of the rudder blade area, situated in front of the centreline of the rudder stock, in m^2 , see *Figure 13.2.2 Rudder co-ordinate system*.

2.4 Rudder torque calculation for rudders with cut-outs

2.4.1 The rudder torque, M_T , is to be determined for both the ahead and astern conditions as follows. The rudder area, A_R , used in the derivation of the rudder torque may be divided into two rectangular or trapezoidal parts with areas A_1 and A_2 , so that $A_R = A_1 + A_2$, see *Figure 13.2.3 Rudder areas*.

$$M_T = M_1 + M_2 \text{ Nm}$$

where

$$M_1 = P_{L1} \times x_{p1} \text{ Nm}$$

$$M_2 = P_{L2} \times x_{p2} \text{ Nm}$$

M_T = the rudder torque, in Nm, to be calculated for both ahead and astern conditions. The greater of these two values are to be used throughout *Pt 3, Ch 13, 2 Rudders*

P_L = lateral force acting on the rudder, in N, as calculated in *Pt 3, Ch 13, 2.2 Lateral force on rudder blade 2.2.1*

$$P_{L1} = \frac{A_1}{A_R} P_L \text{ N}$$

$$P_{L2} = \frac{A_2}{A_R} P_L \text{ N}$$

x_{p1} = $b_{R1} (\alpha - k_1)$, in metres

where

$$x_{P2} = b_{R2} (\alpha - k_2), \text{ in metres}$$

$$A_1 = A_{1a} + A_{1f}, \text{ in m}^2, \text{ see Figure 13.2.3 Rudder areas}$$

$$A_2 = A_{2a} + A_{2f}, \text{ in m}^2, \text{ see Figure 13.2.3 Rudder areas}$$

$$b_{R1} = \text{mean breadth, in metres, of partial area } A_1$$

$$b_{R2} = \text{mean breadth, in metres, of partial area } A_2$$

$$\alpha = \text{as given in Table 13.2.2 Coefficient, } \alpha$$

$$k_1 = \frac{A_{1f}}{A_1}$$

$$k_2 = \frac{A_{2f}}{A_2}$$

For ahead condition M_T is not to be taken less than

$$M_{T, \min} = 0,1 P_L \frac{A_1 b_{R1} + A_2 b_{R2}}{A_R} \text{ Nm}$$

Table 13.2.1 Rudder profile coefficient, c_2

Profile type (see Figure 13.2.1 Rudder profiles)	Ahead	Astern
NACA-00	1,1	0,8
Hollow profiles	1,35	0,9
Flat side profiles	1,1	0,9
High lift profile	1,7	to be specially considered

Note For rudder profiles not defined above, the value of c_2 may be determined on the basis of experimental results. These results are to be submitted for consideration.

Table 13.2.2 Coefficient, α

Condition	Behind fixed structure, (see Note)	Not behind a fixed structure
Ahead	0,25	0,33
Astern	0,55	0,66

Note For rudder parts behind a fixed structure such as a rudder horn.

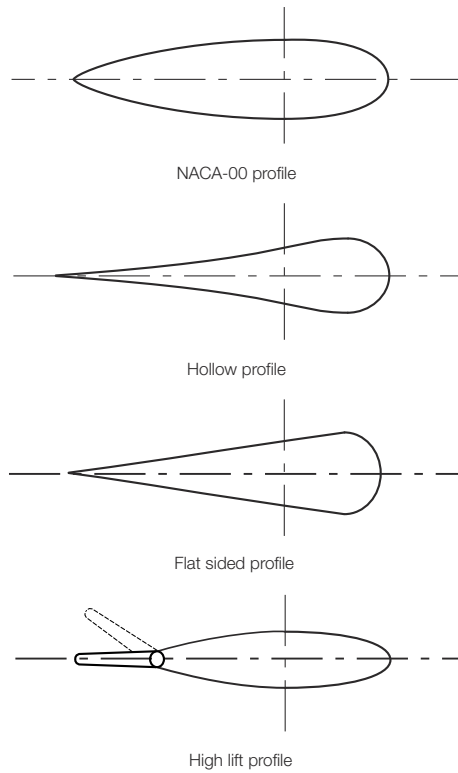

Figure 13.2.1 Rudder profiles

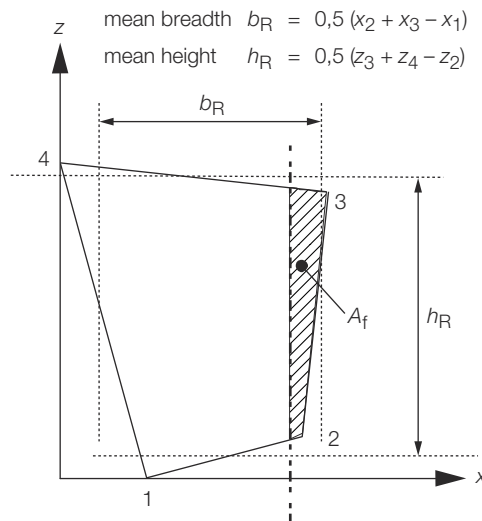

Figure 13.2.2 Rudder co-ordinate system

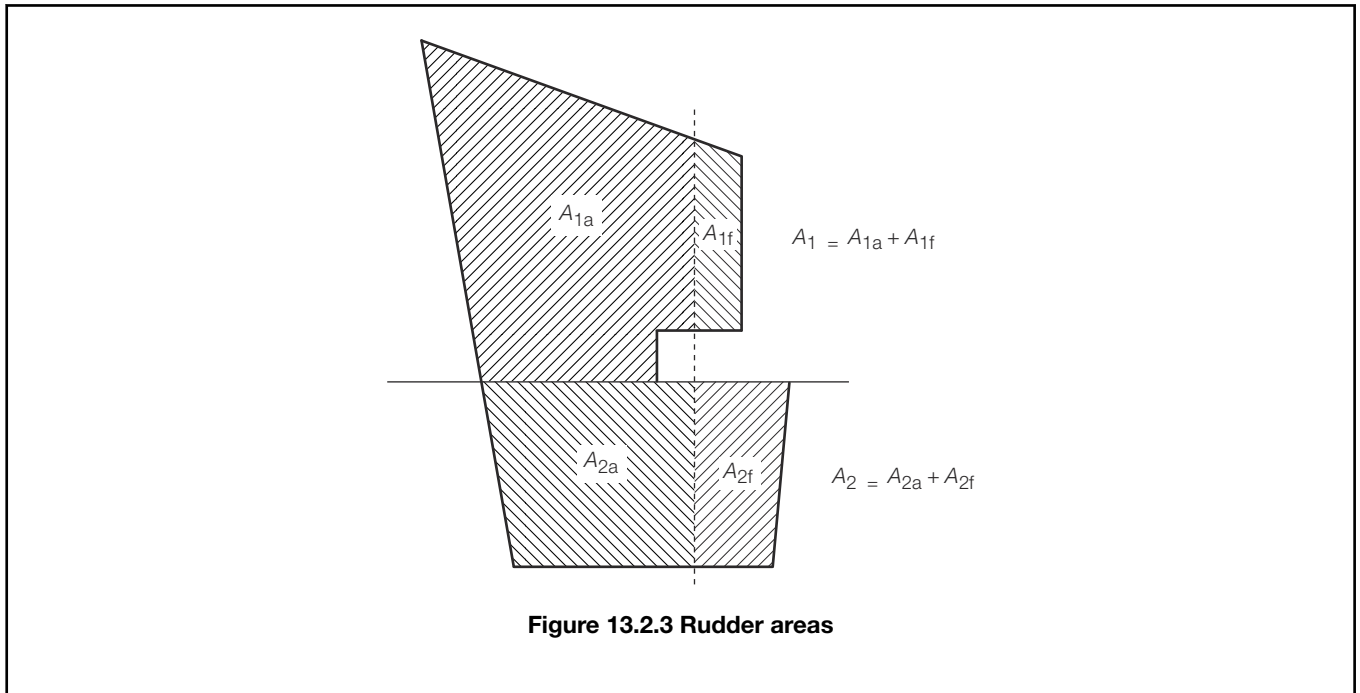

Figure 13.2.3 Rudder areas

2.5 Rudder stock and bearings

2.5.1 The scantlings of the stock are to be not less than required by *Table 13.2.3 Rudder stock diameter*.

2.5.2 For the purpose of this Section, the material factor, k_o , applicable to rudder stocks, pintles, coupling flanges, bolts, keys, etc. is defined in *Table 13.2.4 Material factor k_o* . For higher tensile steel rudder stocks, welding, including cladding, is not generally permitted.

2.5.3 The rudder stock diameter is to be dimensioned such that the stresses do not exceed the permissible stresses given in *Table 13.2.5 Permissible stresses*.

2.5.4 Where reductions in rudder stock diameter due to the application of steels with yield stresses exceeding 235 N/mm^2 are requested, evaluation of the rudder stock deformations may be required. Large deformations are to be avoided in order to avoid excessive edge pressures in way of bearings.

2.5.5 For spade rudders the stock diameter corrected for higher tensile steel is to be greater than 90 per cent of the uncorrected stock diameter unless direct calculations are submitted showing that the slope of the stock at the lowest main bearing does not exceed 0,0035 when the rudder blade is loaded by a lateral force of P_L , acting at the centre of pressure.

2.5.6 For rudders having an increased diameter of the rudder stock in way of the rudder, the increased diameter is to be maintained to a point as far as practicable above the top of the lowest bearing. The diameter may then be tapered to the diameter required in way of the tiller. The length of the taper is to be at least three times the reduction in diameter. Particular care is to be taken to avoid the formation of a notch at the upper end of the taper, see *Figure 13.2.5 Rudder stock taper*.

2.5.7 Sudden changes of section or sharp corners in way of the rudder coupling, jumping collars and shoulders for rudder carriers, are to be avoided. Jumping collars are not to be welded to the rudder stock. Keyways in the rudder stock are to have rounded ends and the corners at the base of the keyway are to be radiused. For stainless steel liners formed by weld deposit, see *Pt 3, Ch 13, 2.9 Pintles 2.9.3*.

2.5.8 Bearings are to comply with the requirements of *Table 13.2.6 Bearing requirements for rudder stock and pintles*. The fitting of bearings is to be carried out in accordance with the manufacturer's recommendations to ensure that they remain secure under all foreseeable operating conditions.

2.5.9 On dredging and reclamation craft classed **A1 protected water service**, the rudder stock diameter may be 84 per cent of that required for ships classed **100A1**.

Table 13.2.3 Rudder stock diameter

Item	Requirement
(1) Basic stock diameter, δ_S , at and below lowest bearing	$\delta_S = \delta_t \sqrt[6]{1 + \frac{4}{3} \left(\frac{M_B}{M_T} \right)^2} \text{ mm}$
(2) Diameter, δ_t , in way of tiller	$\delta_t = 4,2 \sqrt[3]{M_T k_o} \text{ mm}$
Symbols	
<p>M_T = Total rudder torque, in Nm, as calculated in Pt 3, Ch 13, 2.3 Rudder torque calculation for rudders without cut-outs or Pt 3, Ch 13, 2.4 Rudder torque calculation for rudders with cut-outs</p> <p>M_B = bending moment, in Nm, at section considered. If direct calculations of bending moment distribution are not carried out, then M_B at the lowest main bearing or rudder coupling may be taken as:</p> <p>$M_B = \frac{h_R}{10C_r} P_L$, for rudders with heel support</p> <p>$M_B = bP_L$, for spade rudders</p> <p>$M_B = \frac{h_R}{10(1 + C_r)} P_L$, for semi – spade rudders</p> $C_r = \frac{b_R^2}{A_R}$ <p>b = distance, in metres, from centroid of rudder area to the centre of lowest bearing, see Figure 13.2.4 Centroid of rudder area for common rudder types</p> <p>b_R = mean breadth of rudder, in metres, see Figure 13.2.2 Rudder co-ordinate system</p> <p>h_R = mean depth of rudder, in metres, see Figure 13.2.2 Rudder co-ordinate system</p> <p>P_L = rudder force, as defined in Pt 3, Ch 13, 2.2 Lateral force on rudder blade 2.2.1</p> <p>k_o = as defined in Table 13.2.4 Material factor k_o</p>	

Table 13.2.4 Material factor k_o

σ_o	k_o
For $\sigma_o > 235$ (24)	$\left(\frac{235}{\sigma_o} \right)^{0,75} \left(\frac{24}{\sigma_o} \right)^{0,75}$
For $\sigma_o \leq 235$ (24)	$\left(\frac{235}{\sigma_o} \right) \left(\frac{24}{\sigma_o} \right)$
Symbols	

σ_o = minimum yield stress in N/mm² (kgf/mm²)

k_o = higher tensile steel correction factor

Note σ_o is to be taken not greater than 70 per cent of the ultimate tensile strength or 450 N/mm² (45,9 kgf/mm²), whichever is the lesser. σ_o is not to be less than 200 N/mm², see Ch 5, 2.4 Mechanical tests 2.4.6 of the Rules for Materials.

Table 13.2.5 Permissible stresses

Mode	Permissible stress, N/mm ² (kgf/mm ²)	
(1) Torsional shear stress, τ_T	68/ k_o	(6,9/ k_o)
(2) Equivalent stress, σ_e	118/ k_o	(12/ k_o)
Symbols and parameters		
<p>σ_T = equivalent stress</p> $= \sqrt{\frac{\sigma_b^2}{b} + 3\tau^2} \text{ N/mm}^2 \text{ (kgf/mm}^2\text{)}$ <p>σ_b = bending stress</p> $= 10,2 \frac{M_B}{\delta^3} 10^3 \text{ N/mm}^2 \left(1,04 \frac{M_B}{\delta^3} 10^3 \text{ kgf/mm}^2 \right)$ <p>τ_T = torsional shear stress</p> $= 5,1 \frac{M_T}{\delta^3} 10^3 \text{ N/mm}^2 \left(0,52 \frac{M_T}{\delta^3} 10^3 \text{ kgf/mm}^2 \right)$ <p>δ_s = actual stock diameter, as calculated in Table 13.2.3 Rudder stock diameter</p> <p>M_B = bending moment, in Nm, at the section considered. If direct calculations of bending moment distribution are not carried out, then M_B at the lowest main bearing or rudder coupling may be taken as given in Table 13.2.3 Rudder stock diameter</p> <p>M_T = total rudder torque, in Nm, as calculated in Pt 3, Ch 3, 2.2 Definition of fore end region or Pt 3, Ch 3, 2.3 Definition of aft end region</p> <p>k_o = as defined in Table 13.2.4 Material factor k_o</p>		

Table 13.2.6 Bearing requirements for rudder stock and pintles

Item	Requirement	
(1) Bearing surface area	$A_B = \frac{B}{q_a} \text{ mm}^2$	
(2) Bearing length	The length/diameter ratio of the actual bearing surface is not to be greater than 1,2	
(3) Clearance	Bearing material	Minimum clearance (on diameter)
	Metal	0,001 δ + 1,0

	Synthetic	See Notes 1, 3, 4 and 5
(4) Rudder stock main bearing wall thickness	Lesser of $0,2\delta$ or 100	See Note 2
(5) Gudgeon thickness in way of pintle (measured outside bush if fitted)	$b_G \geq 0,25\delta$ but need not normally exceed 125 mm	
Symbols		
<p>A_B = bearing surface area, in mm², defined as the projected area (length x diameter) of liner</p> <p>b = distance, in metres, from centre of rudder area to the centre of lowest bearing</p> <p>b_G = thickness of gudgeon material in way of pintle, in mm</p> <p>c = distance, in metres, from centre of lower pintle to the centre of lowest bearing</p> <p>d = distance, in metres, from centre of lowest bearing to the centre of upper bearing. In the case of semi spade rudder with two pintles, d, is to be measured between the centre of upper pintle and centre of upper bearing</p> <p>δ = diameter of stock, δ_S, given in <i>Table 13.2.3 Rudder stock diameter</i>, or pintle, δ_{PL}, given in <i>Table 13.2.12 Pintle requirements</i>, in mm</p> <p>l_B = length of bearing, in mm</p> <p>q_a = maximum surface pressure, see <i>Table 13.2.7 Maximum surface pressure</i></p> <p>B = bearing force, in N. If direct calculations are not carried out, the bearing force at various positions can be taken as:</p> <p>$B_2 = \left(1 - \frac{b}{c}\right)P_L$, at the lowest main bearing for single pintle rudders and semi-spade rudders, see <i>Figure 13.2.4 Centroid of rudder area for common rudder types (a), (c) and (d)</i>. B_2 is not to be less than $0,35P_L$</p> <p>$B_2 = P_L + B_3$, at lowest main bearing for spade rudders, see <i>Figure 13.2.4 Centroid of rudder area for common rudder types (b)</i></p> <p>$B_3 = \left(\frac{M_B}{d}\right)$, at upper bearing for spade rudders, see <i>Figure 13.2.4 Centroid of rudder area for common rudder types(b)</i>. For bearing force at pintles, see <i>Table 13.2.12 Pintle requirements</i></p>		
<p>Note 1 If non-metallic bearing material is applied, the bearing clearance is to be specially determined considering the material's swelling and thermal expansion properties. This clearance is not to be less than 1,5 mm on bearing diameter unless a smaller clearance is supported by the manufacturer's recommendation and there is documented evidence of satisfactory service history with a reduced clearance.</p> <p>Note 2 Where web stiffening is fitted on the bearing, a reduction in wall thickness will be considered.</p> <p>Note 3 For bearings which are pressure lubricated the clearance must be restricted to enable the pressure to be maintained.</p> <p>Note 4 The value of the proposed minimum clearance is to be indicated on plans submitted for approval.</p> <p>Note 5 Proposals for higher pressures or other materials will be specially considered on the basis of satisfactory test results.</p>		

Table 13.2.7 Maximum surface pressure

Bearing material	q_a (N/mm ²) (see Note 1)
Lignum vitae	2,5
White metal, oil lubricated	4,5
Synthetic material with hardness between 60 and 70 Shore D (see Note 2)	5,5

Steel (see Note 3) and bronze and hotpressed bronze-graphite materials	7,0
<p>Note 1. Proposals for higher pressures will be specially considered on the basis of satisfactory test results.</p> <p>Note 2. Indentation hardness test at 23°C and with 50% moisture, according to a Recognised Standard. Synthetic bearing materials are to be of an approved type.</p> <p>Note 3. Stainless and wear-resistant steel in an approved combination with stock liner.</p>	

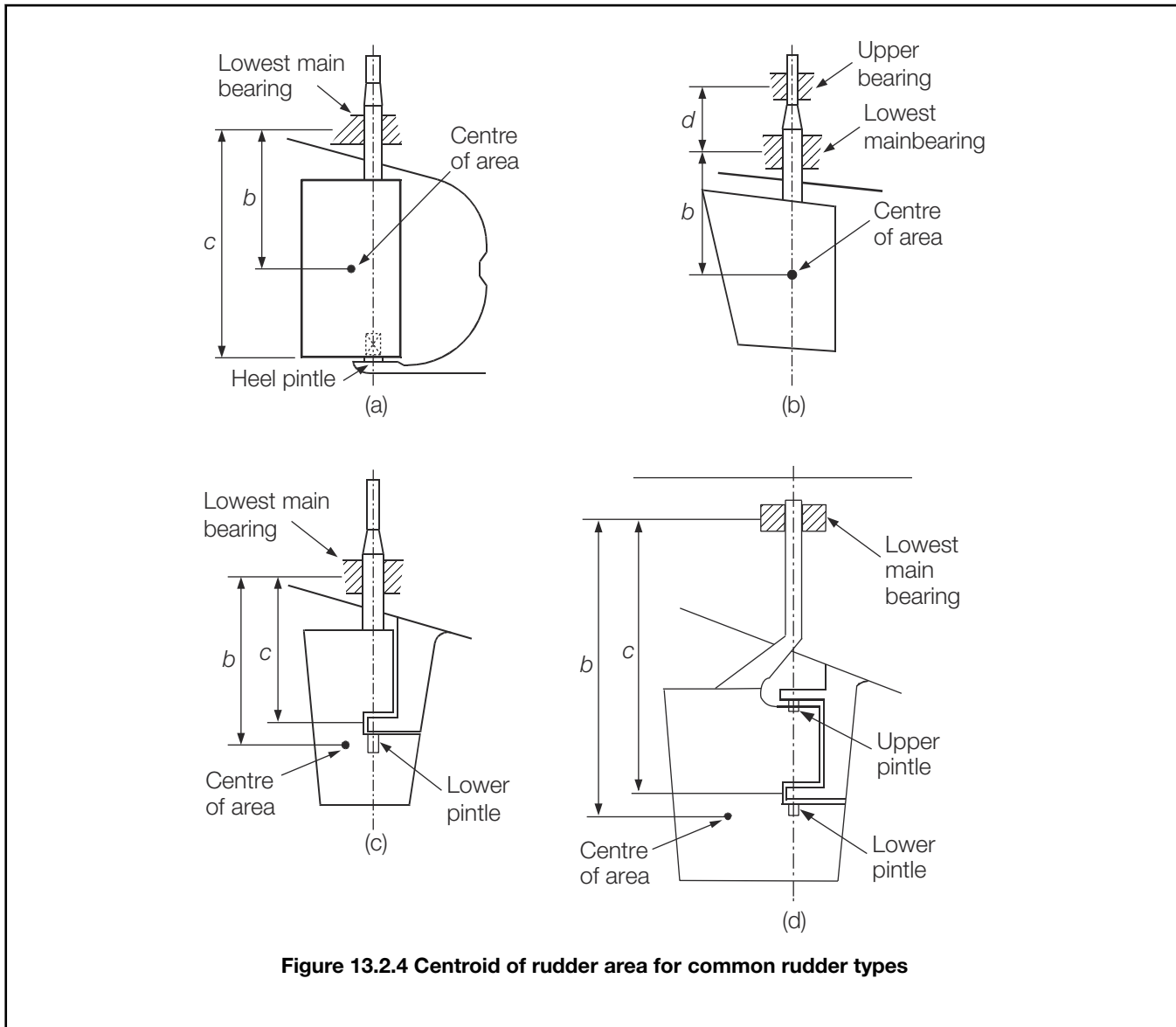
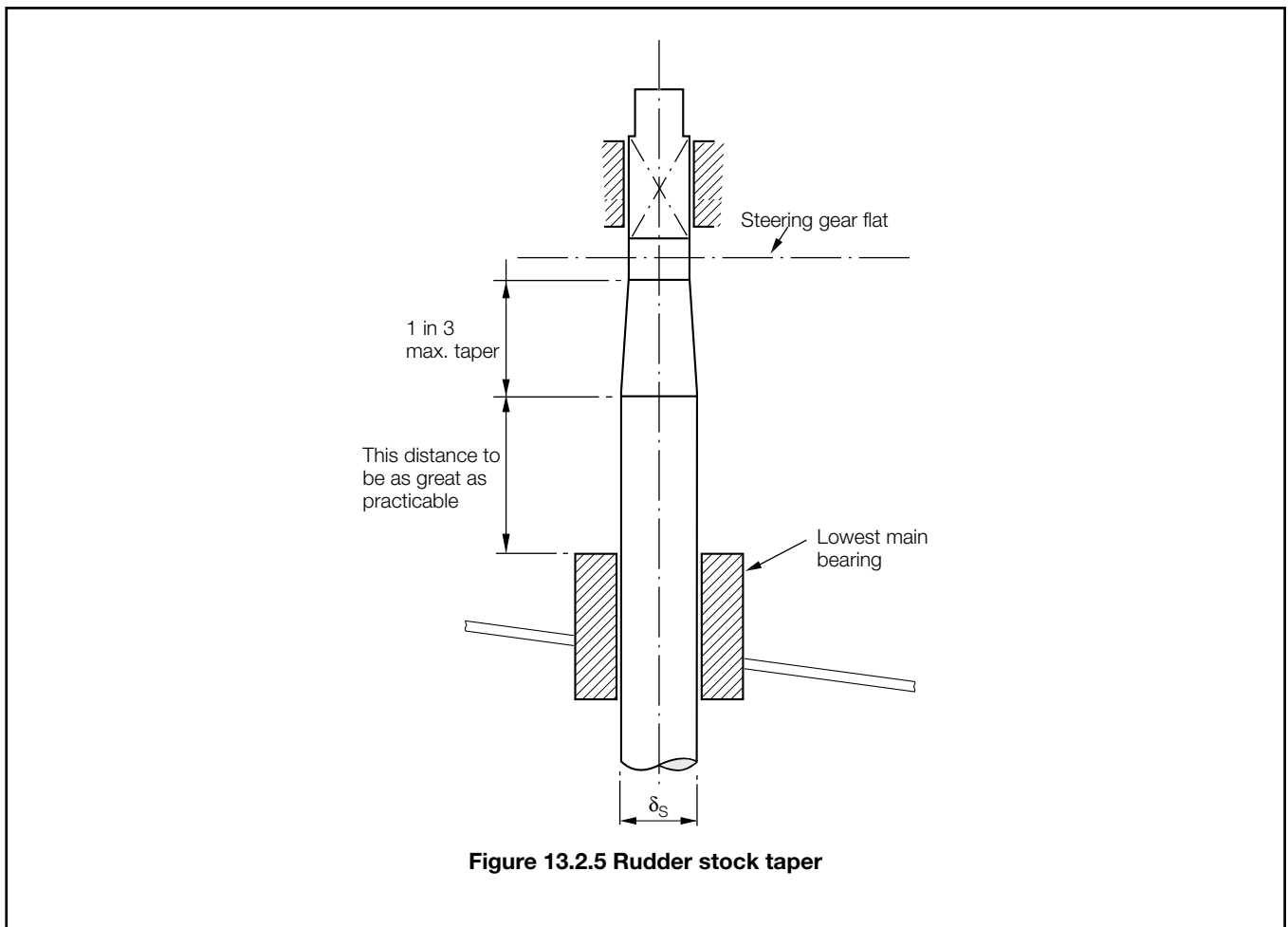

Figure 13.2.4 Centroid of rudder area for common rudder types



2.6 Rudder construction – Double plated

2.6.1 The scantlings of a double plated rudder are to be not less than required by *Table 13.2.8 Single and double plated rudder construction*.

2.6.2 The rudder is to be dimensioned such that the stresses do not exceed the permissible stresses given in *Table 13.2.9 Permissible stresses for rudder blade scantlings*.

2.6.3 In way of rudder couplings and heel pintles, the plating thickness is to be suitably increased.

2.6.4 On semi-spade/mariner type rudders the following items are to be complied with:

- (a) The main vertical web forming the mainpiece is to be continuous over the full depth of the rudder.
- (b) The thickness of the main vertical web is to be not less than two times the thickness required by *Table 13.2.8 Single and double plated rudder construction* from the top of the rudder to the lower pintle. The thickness is to be not less than required by *Table 13.2.8 Single and double plated rudder construction* from the lower pintle to approximately a point midway between the lower pintle and bottom of the rudder. Below this the thickness, t_2 is to be not less than the thickness required by *Table 13.2.8 Single and double plated rudder construction*. See *Figure 13.2.6 Main vertical web thickness*.
- (c) Where an additional continuous main vertical web is arranged to form an efficient box mainpiece structure, the thickness of each web is to be not less than that required by *Table 13.2.8 Single and double plated rudder construction* from the top of the rudder to approximately a point midway between the lower pintle and bottom of the rudder. Below this the thickness, t_2 , is not to be less than that required by *Table 13.2.8 Single and double plated rudder construction*.
- (d) The internal radius, r , of the cut-out for the rudder pintle is to be as large as practicable. See *Figure 13.2.6 Main vertical web thickness*.
- (e) To reduce the notch effect at the corners of the cut-out for the lower pintle, an insert plate 1,6 times the Rule thickness of the side plating is to be fitted. The insert plate is to extend aft of the main vertical web and to have well rounded corners.

2.6.5 Adequate hand or access holes are to be arranged in the rudder plating in way of pintles as required, and the rudder plating is to be reinforced locally in way of these openings. Continuity of the modulus of the rudder mainpiece is to be maintained in way of the openings.

2.6.6 Connection of rudder side plating to vertical and horizontal webs, where internal access for welding is not practicable, is to be by means of slot welds on to flat bars on the webs. The slots are to have a minimum length of 75 mm and, in general, a minimum width of twice the side plating thickness. The ends of the slots are to be rounded. The space between the slots is not to exceed 150 mm and welding is to be based on a weld factor of 0,44.

2.6.7 For testing of rudders, see *Table 1.9.1 Testing requirements* in Chapter 1.

2.6.8 Where the fabricated mainpiece of a spade rudder is connected to the horizontal coupling flange by welding, a full penetration weld is required.

2.7 Rudder construction – Single plated

2.7.1 The scantlings of a single plated rudder are to be not less than required by *Table 13.2.8 Single and double plated rudder construction*.

2.7.2 Rudder arms are to be efficiently attached to the mainpiece.

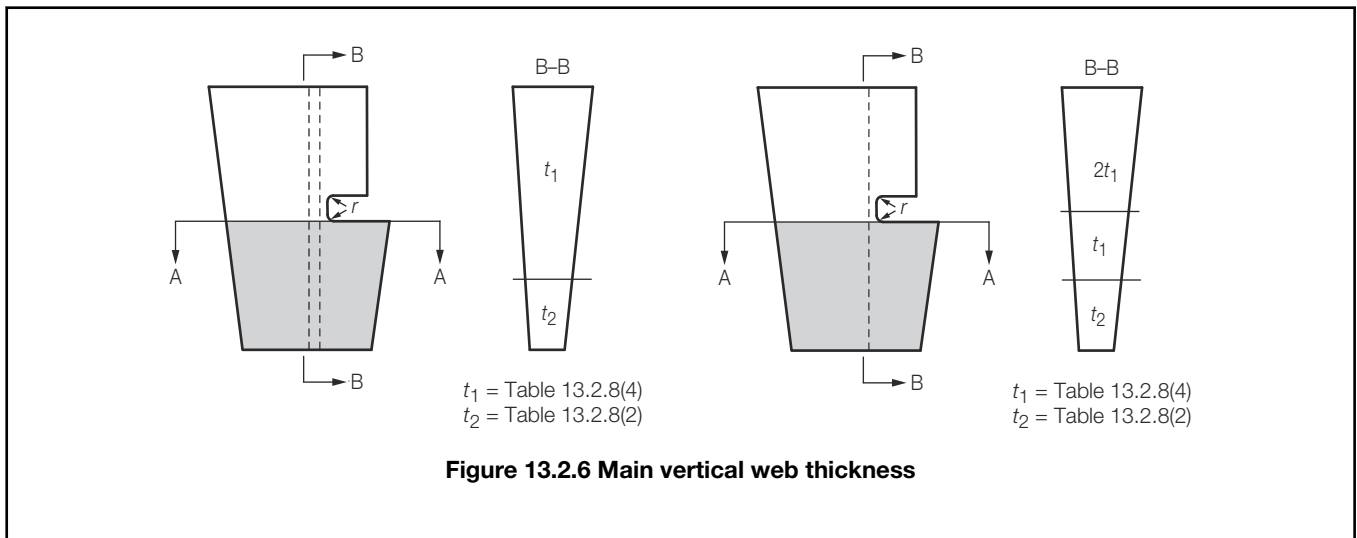

Table 13.2.8 Single and double plated rudder construction

Type	Item	Requirement
Double plated rudder construction	(1) Rudder side, top and bottom plating	$t = 5,5 s_{\min} s_e \sqrt{\left(T + \frac{P_L 10^{-4}}{A_R} \right) k} + 2,5 \text{ mm}$
	(2) Webs vertical and horizontal	$t_W = 0,7 t$ from (1) but is not to be less than 8 mm
	(3) Nose plate	$t_N = 1,25t$ from (1) but need not exceed 22 mm
	(4) Mainpiece fabricated rectangular, see Note 1	Breadth and width $\geq \delta_S$ $t_M = 8,5 + 0,56 \sqrt{\delta_S}^3 \sqrt{k} \text{ mm}$ Minimum fore and aft extent of side plate = $0,2b_R$ Stress due to bending, see Table 13.2.9 Permissible stresses for rudder blade scantlings
	(5) Mainpiece tubular, see Note 1	Inside diameter $\geq \delta_S$ t_M as for (4) Side plating as for (1) Bending stress as for (4)
	(6) Mainpiece semi-spade (Mariner) type rudders in way of lower pintle regions, see Note 2	Bending moment applied at section 'AA' (see Figure 13.2.6 Main vertical web thickness) by the underhung position to result in stresses not greater than those given in Table 13.2.9 Permissible stresses for rudder blade scantlings
Single plated rudder construction	(7) Blade thickness	$t_B = 0,0015V y_w + 2,5 \text{ mm}$ with a minimum of 10 mm
	(8) Arms	Spacing $\leq 1000 \text{ mm}$ $Z_A = 0,0005 V^2 x_a^2 y_w \text{ cm}^3$ thickness = t_B in mm with a minimum of 10 mm
	(9) Mainpiece	Diameter $\geq \delta_S$ for spade rudders, the lower third may be tapered down to $0,75\delta_S \text{ mm}$ at the bottom end
Symbols		

b_R = mean breadth of rudder at centreline of stock, in mm

k = see Note 3

$$s_e = \sqrt{1,1 - 0,5 \left(\frac{s_{\min}}{s_{\max}} \right)^2} \text{ but not more than } 1,00 \text{ if } \frac{s_{\max}}{s_{\min}} \geq 2,5$$

s_{\max} = greatest unsupported width of plating, in metres

s_{\min} = smallest unsupported width of plating, in metres

t = thickness, in mm

t_W = thickness of webs, in mm

t_M = thickness of side plating and vertical webs forming mainpiece, in mm

t_N = thickness of nose plate, in mm

x_a = horizontal distance from the aft edge of the rudder to the centre of the rudder stock, in metres

y_w = vertical spacing of rudder arms, in mm. Not to exceed 1000 mm

A_R = rudder area, in m²

P_L = rudder force, as defined in Pt 3, Ch 3, 2.1 Definition of requirements 2.1.1

T = as given in Pt 3, Ch 1, 6.1 Principal particulars

V = as defined in Pt 3, Ch 3, 2.1 Definition of requirements 2.1.1

Z_A = section modulus of arm, in cm³

δ_S = basic stock diameter, given by Table 13.2.3 Rudder stock diameter, in mm

Note 1 The value of the basic stock diameter δ_S , used in (4) and (5), is that for mild steel, as given in Table 13.2.3 Rudder stock diameter.

Note 2 The effective breadth of the side plate may be taken as $0,16h_R$.

Note 3 For higher tensile steels, the material factor $k = 0,78$ for steels with $\delta_y = 315 \text{ N/mm}^2$ and $k = 0,72$ for steels with $\delta_y = 355 \text{ N/mm}^2$.

Table 13.2.9 Permissible stresses for rudder blade scantlings

Item	Permissible stresses, in N/mm ² (kgf/mm ²)		
	Bending stress	Shear stress	Equivalent stress
Rudder blades clear of cut-outs, see Figure 13.2.2 Rudder co-ordinate system	$\frac{110}{k} \left(\frac{11,2}{k} \right)$	$\frac{50}{k} \left(\frac{5,1}{k} \right)$	$\frac{120}{k} \left(\frac{12,2}{k} \right)$
Rudder blades in way of cut-outs, see Figure 13.2.2 Rudder co-ordinate system and Note	$\frac{75}{k} \left(\frac{7,6}{k} \right)$	$\frac{50}{k} \left(\frac{5,1}{k} \right)$	$\frac{100}{k} \left(\frac{10,2}{k} \right)$
Symbols			
k as defined in Pt 3, Ch 13, 1.2 General symbols 1.2.1			
Note Requirements in way of cut-outs apply to semi-spade/mariner type rudders.			

2.8 Rudder couplings

- 2.8.1 Rudder coupling design is to be in accordance with *Table 13.2.10 Rudder couplings to stock - Bolted couplings*.
- 2.8.2 Where coupling bolts are required they are to be fitted bolts. Suitable arrangements are to be made to lock the nuts.
- 2.8.3 For rudders with horizontal coupling arrangements the rudder stock should be forged when the stock diameter exceeds 350 mm. Where the stock diameter does not exceed 350 mm the rudder stock may be either forged or fabricated. Where the upper flange is welded to the rudder stock, a full penetration weld is required and its integrity is to be confirmed by non-destructive examination. The flange material is to be from the same welding materials group as the stock. Such rudder stocks are to be subjected to a furnace post-weld heat treatment (PWHT) after completion of all welding operations. For carbon or carbon manganese steels, the PWHT temperature is not to be less than 600°C.
- 2.8.4 For a spade rudder, the fillet radius between the rudder stock and the flange is to conform to the requirements of *Figure 13.2.7 Rudder stock horizontal flange fillet radius for spade rudders*. Where space permits between the upper face of the flange and the lowest main bearing, it is preferable to use a compound fillet design of the parabolic or Morgenbrod form having similar dimensions to those of *Figure 13.2.7 Rudder stock horizontal flange fillet radius for spade rudders*. Alternative arrangements will be specially considered.
- 2.8.5 The connecting bolts for coupling the rudder to the rudder stock are to be positioned with sufficient clearance to allow the fitting and removal of the bolts and nuts without contacting the palm radius, R , see *Figure 13.2.8 Rudder stock connection(a)*. The surface forming the palm radius is to be free of hard and sharp corners and is to be machined smooth to the Surveyor's satisfaction. The surface in way of bolts and nuts is to be machined smooth to the Surveyor's satisfaction.
- 2.8.6 For spade rudders fitted with a fabricated rectangular mainpiece, the mainpiece is to be designed with its forward and aft transverse sections at equal distances forward and aft of the rudder stock transverse axis, see *Figure 13.2.8 Rudder stock connection(b)*.
- 2.8.7 Where a rudder stock is connected to a rudder by a keyless fitting, the rudder is to be a good fit on the rudder stock cone. During the fit-up, and before the push-up load is applied, an area of contact of at least 80 per cent of the theoretical area of contact is to be achieved, and this is to be evenly distributed. The relationship of the rudder to stock at which this occurs is to be marked, and the push-up then measured from that point. The upper edge of the upper mainpiece bore is to have a slight radius. After final fitting of the stock to the rudder, positive means are to be used for locking the securing nut to the stock.
- 2.8.8 Where a keyed conical fitting of a rudder stock to a rudder is proposed, a securing nut is to be provided. Minimum dimensions for the securing nut are given in *Table 13.2.10 Rudder couplings to stock - Bolted couplings*. After final fitting of the stock to the rudder, positive means are to be used for locking this nut.
- 2.8.9 Guidelines for keys and keyways are given in *Table 13.2.10 Rudder couplings to stock - Bolted couplings*.

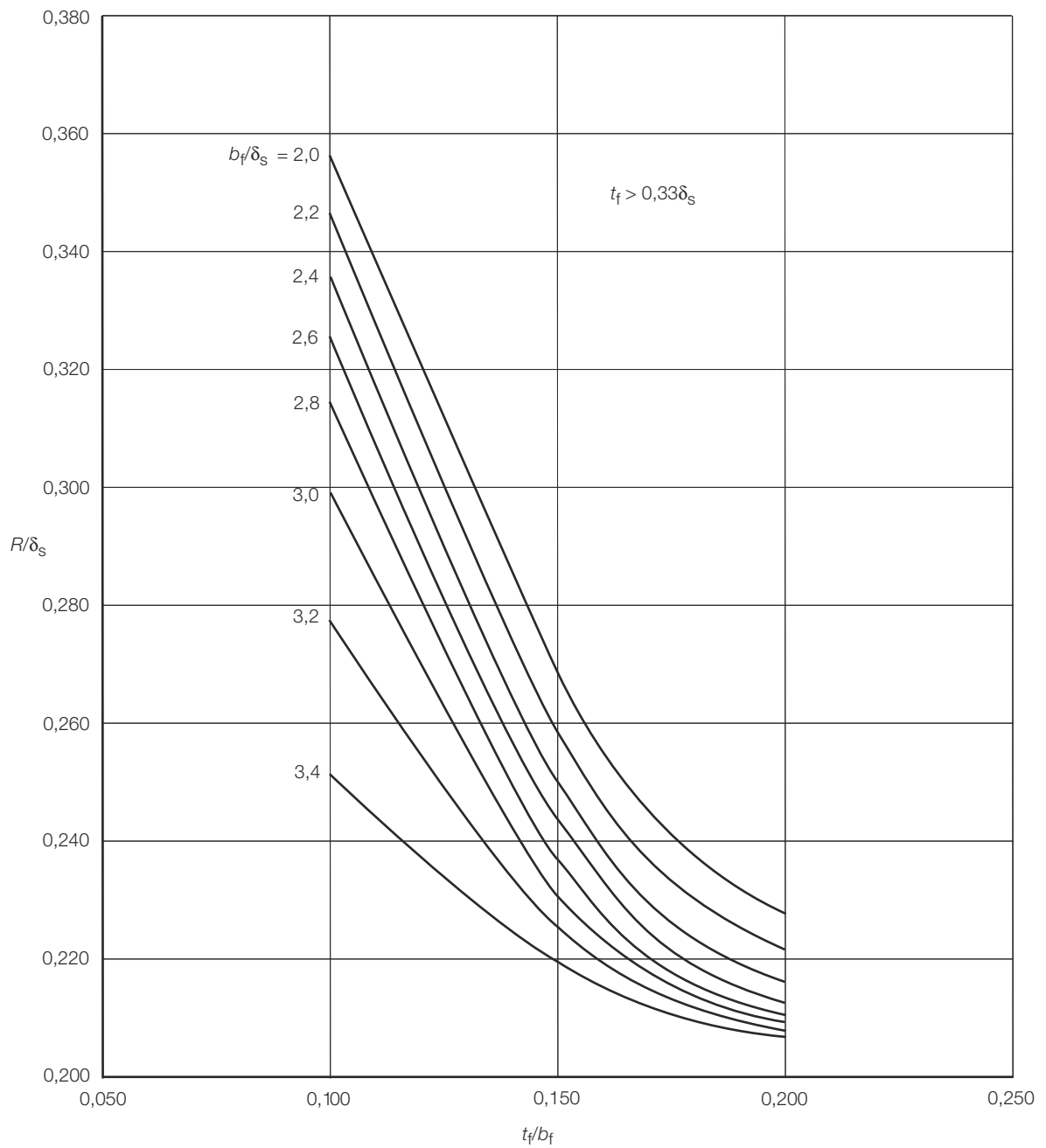

Figure 13.2.7 Rudder stock horizontal flange fillet radius for spade rudders

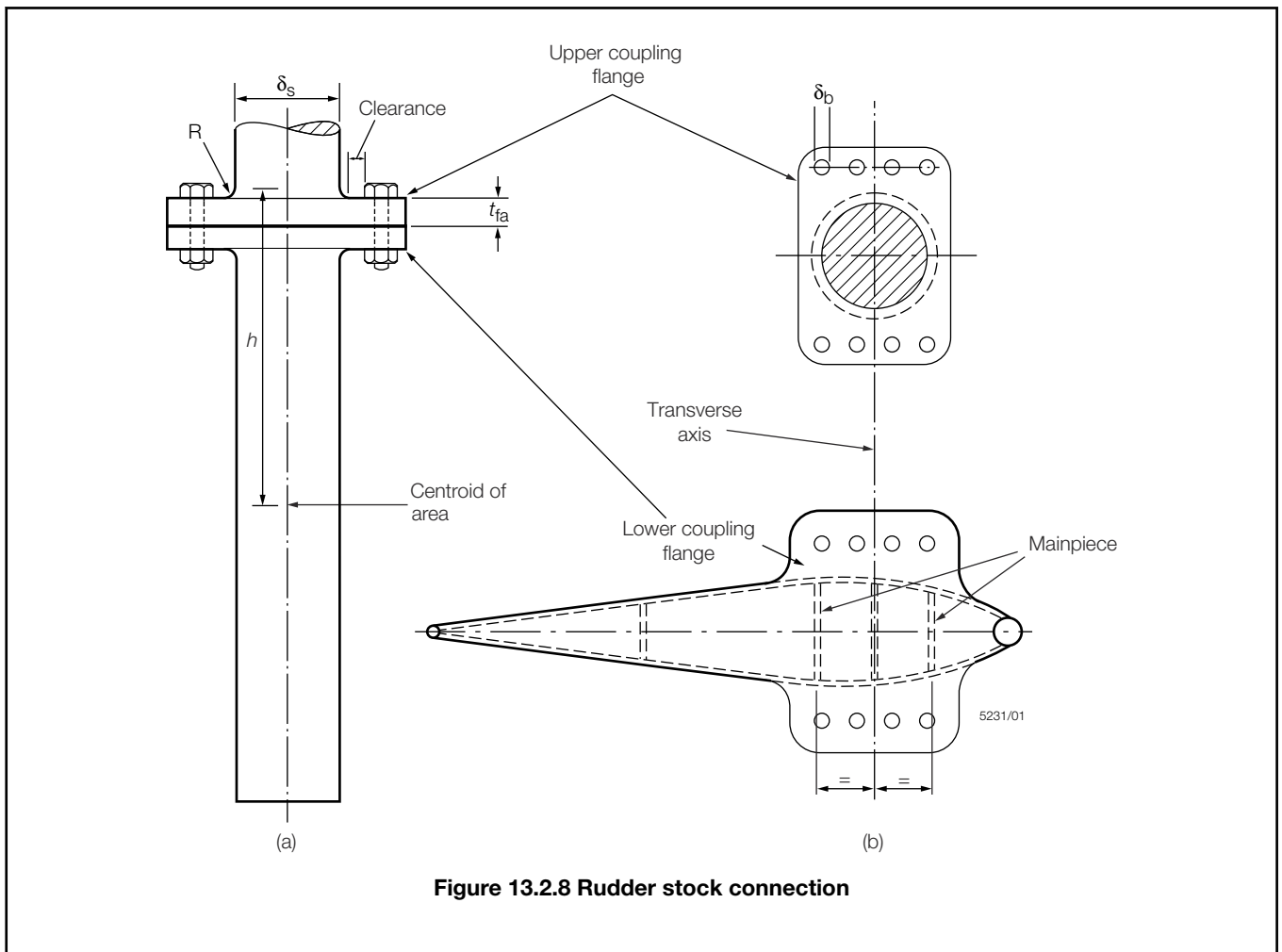

Figure 13.2.8 Rudder stock connection

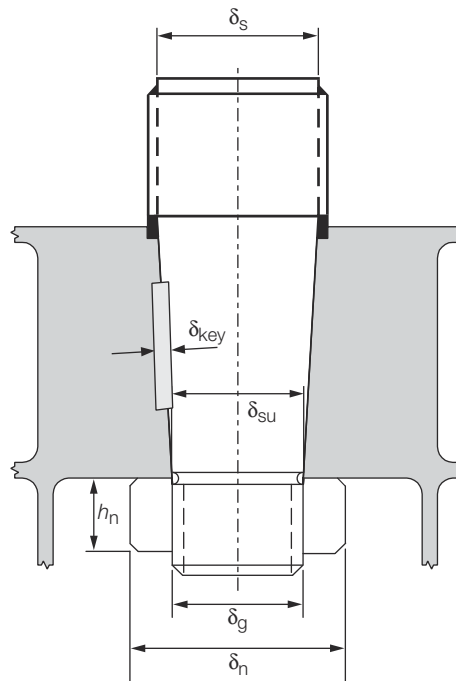

Figure 13.2.9 Conical coupling

Table 13.2.10 Rudder couplings to stock - Bolted couplings

Item	Requirement	
	Horizontal coupling	Vertical coupling
Number of bolts in coupling	$n \geq 6$	$n \geq 8$
Diameter of coupling bolts	$\delta_b = 0,62 \sqrt{\frac{\delta_s^3 k_b}{l_a n k_s}}$	$\delta_b = 0,81 \delta_s \sqrt{\frac{k_b}{n k_s}}$
First moment of area of bolts about centre of coupling	$m = 0,00071 n \delta_s \delta_b^2 \sqrt{\frac{k_b}{k_s}}$	$m = 0,00043 \delta_s^3 \sqrt{\frac{k_b}{k_s}}$
Thickness of coupling flange	$t_f = \delta_b \sqrt{\frac{k_b}{k_s}}$ (see Notes 1 and 2)	$t_f = \delta_b$
Stress concentration factor for as built scantlings	α as built $\leq \alpha$ max (see Note 3)	-

Maximum allowable stress concentration factor	$\alpha_{\max} = (53,82 - 35,29k_{\max}) \frac{\delta_S^3}{hP_L 10^3} - \left(1,8 - 6,3 \frac{R}{\delta_S}\right) \frac{t_f - t_{fa}}{t_{fa}} \text{ (see Note 3)}$	-
Width of flange material outside the bolt holes	$w_f = 0,67 \delta_b$	$w_f = 0,67 \delta_b$
Symbols		
<p>$\alpha_{\text{as built}}$ = stress concentration factor for as built scantlings</p> $= \frac{0,73}{\sqrt{\frac{R}{\delta_S}}}$ <p>α_{max} = maximum allowable stress concentration factor</p> <p>δ_b = diameter of coupling bolts, in mm</p> <p>δ_S = basic stock diameter as defined in <i>Table 13.2.3 Rudder stock diameter</i>, in mm</p> <p>b_f = breadth of the flange, in mm</p> <p>h = vertical distance, in metres, between the centre of pressure and the centre point of the palm radius, see <i>Figure 13.2.8 Rudder stock connection</i></p> <p>k_b = coupling bolt material factor, see <i>Pt 3, Ch 13, 2.5 Rudder stock and bearings 2.5.2</i></p> <p>k_{\max} = the greater of k_s and k_f</p> <p>k_f = upper coupling flange material factor, see <i>Pt 3, Ch 13, 2.5 Rudder stock and bearings 2.5.2</i></p> <p>k_s = rudder stock material factor, see <i>Pt 3, Ch 13, 2.5 Rudder stock and bearings 2.5.2</i></p> <p>l_a = the mean of the horizontal distances between the centres of the bolts and the centre of the coupling, in mm</p> <p>m = first moment of area of bolts about a longitudinal axis through centre of coupling, in cm³</p> <p>n = number of bolts in coupling</p> <p>P_L = lateral force on rudder as defined in <i>Pt 3, Ch 13, 2.2 Lateral force on rudder blade 2.2.1</i>, in N (tonne-f)</p> <p>R = palm radius, in mm, between the rudder stock and connection flange, see <i>Pt 3, Ch 13, 2.8 Rudder couplings 2.8.4 and Pt 3, Ch 13, 2.8 Rudder couplings 2.8.5</i>.</p> <p>t_f = minimum thickness of coupling flange, in mm</p>		

t_{fa} = as built flange thickness, in mm

w_f = width of flange material outside the bolt holes, in mm

Note 1. For spade rudders with horizontal couplings, t_f is not to be less than $0,33 \delta_s \sqrt[3]{k_s}$. The mating plate on the rudder is to have the same thickness as the flange on the stock

Note 2. For a twin spade rudder arrangement with single screw where the rudders are within the slipstream of the propeller: (a) the thickness of the palm is not to be less than $0,35 \delta_s \sqrt[3]{k_s}$ (b) where the stock is welded to the palm plate, the stock diameter, δ_s is to be increased by 14%.

Note 3 This requirement is applicable only for spade rudders with horizontal couplings, see *Figure 13.2.6 Main vertical web thickness*.

Table 13.2.11 Rudder couplings to stock - Conical couplings

Item	Requirement
Taper of conical coupling on the diameter	$\theta_t \leq \frac{1}{K_1}$
Length of taper	$l_t \geq 1,5 \delta_s$
Required mean grip stress – keyless connection	$p_M = \frac{P_R \theta_t \delta_{CTM} + 4M_T 10^3 \sqrt{K_2 \left(\left[\frac{P_R \delta_{CTM}}{2000M_T} \right]^2 + 1 \right) - \left(\frac{\theta_t}{2} \right)^2}}{5,03 \delta_{CTM}^2 l_t \left(K_2 - \left(\frac{\theta_t}{2} \right)^2 \right)}$
Required mean grip stress – keyed connection	$p_M = 20$
Corresponding push-up of rudder stock	$w = \frac{9,6 \cdot 10^{-6} p_M \delta_{CTM}}{\theta_t (1 - f_{M2})} \left(\frac{0,95 \cdot 10^{-4} p_M \delta_{CTM}}{\theta_t (1 - f_{M2})} \right)$
Corresponding push-up load	Approximately equal to $P_U = 0,8 \pi p_M l_t \delta_{CTM} \left(k_3 + \frac{\theta_t}{2} \right)$
Corresponding pull-off load	Approximately equal to $P_O = 2,83 p_M l_t \delta_{CTM} \left(k_3 - \frac{\theta_t}{2} \right)$
Minimum yield stress of stock and gudgeon	$\sigma_o = \frac{123500 w \theta}{\delta_{CT}} \sqrt{3 + f^4} \left(\frac{12600 w \theta}{\delta_{CT}} \sqrt{3 + f^4} \right)$
Recommended minimum effective sectional area of the key in shear	$A_{key} = \frac{M_T k_{min}}{3,3 \delta_{CTM}}$ see Note
Minimum thickness of key	$\delta_{key} = \frac{67 A_{key}}{H}$
Minimum dimensions of securing nut	$\delta_g = 0,65 \delta_s$ $\delta_n = 1,2 \delta_{SU}$ or $1,5 \delta_g$ whichever is the greater $h_n = 0,6 \delta_g$

Symbols

h_n = minimum required length of securing nut, in mm, see *Figure 13.2.8 Rudder stock connection*

$$f = \frac{\delta_{CT}}{\delta_{GH}}$$

$$f_M = \frac{\delta_{CTM}}{\delta_{GHM}}$$

k_{min} = taken as k_0 , where σ_0 is the minimum nominal upper yield point of the key, stock or coupling material, in N/mm², whichever is less

k_0 = material factor as defined in *Table 13.2.3 Rudder stock diameter*, for the appropriate item

l_t = length of taper, in mm

p_M = required mean grip stress, in N/mm²

w = corresponding push-up of rudder stock, in mm

A_{key} = recommended minimum effective sectional area of the key in shear, in cm²

H = length of the key, in mm

M_T = rudder torque, in Nm, as given in *Table 13.2.5 Permissible stresses*

P_R = effective weight of rudder, in N (kgf)

P_U, P_O = corresponding push-up, pull-off loads respectively, in N (kgf)

δ_g = minimum external thread diameter, in mm, see *Figure 13.2.8 Rudder stock connection*

δ_n = minimum outer diameter of nut, in mm, see *Figure 13.2.8 Rudder stock connection*

δ_{CT} = diameter of coupling taper in any position, in mm

δ_{CTM} = mean diameter of coupling taper, in mm

$$= \frac{\delta_S + \delta_{SU}}{2}$$

δ_{GH} = external diameter of gudgeon housing at any position, in mm

δ_{GHM} = mean external diameter of gudgeon housing, in mm

δ_{key} = minimum thickness of key. See *Figure 13.2.8 Rudder stock connection*

δ_{SU} = see Figure 13.2.8 Rudder stock connection, in mm

σ_o = minimum yield stress of stock and gudgeon material, in N/mm² (kgf/mm²) σ_o is not to be taken greater than 70% of the ultimate tensile strength or 450 N/mm² (45,9 kgf/mm²) whichever is the lesser

θ_t = taper of conical coupling, on the diameter, e.g. $\frac{1}{15} = 0,067$

K_1, K_2, K_3 = constants depending on the type of assembly adopted as follows:

Type of assembly		K_1	K_2	K_3
Oil injection	With key	12	—	0,025
	Without key	15	0,0036	0,025
Dry fit method	With key	8	—	0,170
	Without key	12	0,0072	0,170

Note The keyway is to have a smooth fillet at the bottom of the keyway. The radius of the fillet is to be at least 0,0125 of the diameter of the rudder stock at the top of the cone.

2.9 Pintles

- 2.9.1 Rudder pintles and their bearings are to comply with the requirements of *Table 13.2.12 Pintle requirements*.
- 2.9.2 The distance between the lowest rudder stock bearing and the upper pintle should be as short as possible.

Table 13.2.12 Pintle requirements

Item	Requirement	
(1) Pintle diameter	$\delta_{PL} = 0,35\sqrt{B k_o}$ mm	
(2) Pintle taper	Method of assembly	Taper (on diameter)
	Keyed and other manually assembled pintles	1:8 – 1:12
	Pintles mounted with oil injection and hydraulic nut	1:12 – 1:20
Symbols		
<p>b = distance in metres, from centroid of rudder area to the centre of lowest main bearing, see Figure 13.2.4 Centroid of rudder area for common rudder types</p> <p>c = distance, in metres, from centre of bearing of lower pintle to the centre of lowest main bearing, see Figure 13.2.4 Centroid of rudder area for common rudder types</p> <p>k_o = as defined in Table 13.2.3 Rudder stock diameter or Table 13.2.4 Material factor k_o</p> <p>B = bearing force, in N. If direct calculations are not carried out, the bearing force at various positions can be taken as:</p> <p>$B_{1L} = \frac{b}{c} P_L$ for single pintle rudders and lower pintle of semi – spade rudders</p> <p>$B_{1U} = \left(1 - \frac{b}{c}\right) P_L$ at upper pintle on semi – spade rudder. B_{1U} is not to be less than $0,35P_L$</p> <p>$B = \frac{1}{N_{PL}} P_L$ for rudders with two or more pintles (except semi – spade rudders)</p> <p>N_{PL} = number of pintles on the rudder</p> <p>P_L = rudder force, as defined in Pt 3, Ch 13, 2.2 Lateral force on rudder blade 2.2.1</p>		
Note The length of the pintle housing in the gudgeon is not to be less than the maximum pintle diameter.		

2.9.3 Where liners are fitted to pintles, they are to be shrunk on or otherwise efficiently secured. If liners are to be shrunk on, the shrinkage allowance is to be indicated on the plans. Where liners are formed by stainless steel weld deposit, the pintles are to be of weldable quality steel and details of the procedure are to be submitted, see also Pt 3, Ch 13, 2.10 Ancillary items 2.10.4.

2.9.4 The bottom pintle on semi-spade (Mariner) type rudders and all pintles over 500 mm in diameter are:

- (a) if inserted into their sockets from below, to be keyed to the rudder or sternframe as appropriate or to be hydraulically assembled, with the nut adequately locked, or
- (b) if inserted into their sockets from above, to be provided with an appropriate locking device, the nut being adequately secured.

2.9.5 Fitting of pintle bearings is to be carried out in accordance with the bearing manufacturer's recommendations to ensure that they remain secure under all foreseen operating conditions.

2.9.6 Where an ***IWS** (In-water Survey) notation is to be assigned (see Pt 1, Ch 2, 2.3 Class notations (hull) 2.3.11), means are to be provided for ascertaining the rudder pintle and bush clearances and for verifying the security of the pintles in their sockets with the vessel afloat.

2.9.7 For axle type rudder support used with Simplex rudders, see Pt 3, Ch 6, 7 Sternframes and appendages.

2.10 Ancillary items

2.10.1 Internal surfaces of double plate rudders are to be efficiently coated. Alternatively, where it is intended to fill the rudder with plastic foam or use a corrosion inhibitor, details are to be submitted. Means for draining the rudder are to be provided.

2.10.2 Where a bow rudder is fitted for use when navigating astern, a locking device is to be arranged to ensure that the rudder is kept in the central position when the ship is navigating ahead.

2.10.3 Where the weight of the rudder is supported by a carrier bearing attached to the rudder head, the structure in way is to be adequately strengthened. The plating under all rudder head bearings or rudder carriers is to be increased in thickness.

2.10.4 Where it is proposed to use stainless steel for liners or bearings for rudder stocks and/or pintles, the chemical composition is to be submitted for approval. Synthetic rudder bearing materials are to be of a type approved by Lloyd's Register (hereinafter referred to as 'LR'). When this type of lining material is used, arrangements to ensure an adequate supply of sea-water to the bearing are to be provided.

■ Section 3 Fixed and steering nozzles

3.1 General

3.1.1 The requirements for scantlings for fixed and steering nozzles are given, for guidance only, in *Pt 3, Ch 13, 3.2 Nozzle structure to Pt 3, Ch 13, 3.4 Ancillary items* and *Table 13.3.1 Nozzle construction requirements*.

3.1.2 The requirements, in general, apply to nozzles with a numeral not greater than 200, see *Table 13.3.1 Nozzle construction requirements*. Nozzles exceeding this value will be specially considered.

Table 13.3.1 Nozzle construction requirements

Item	Requirement
(1) Nozzle numeral	$N_N = 0,01P\delta_p$ $(N_N = 0,00736H\delta_p)$
(2) Shroud plating in way of propeller blade tips	For $N_N \leq 63$ $t_s = (11 + 0,1 N_N)$ mm For $N_N > 63$ $t_s = (14 + 0,052N_N)$ mm
(3) Shroud plating clear of blade tips, flare and cone plating, wall thickness of leading and trailing edge members	$t_p = (t_s - 7)$ mm but not less than 8 mm
(4) Webs and ring webs	As item (3) except in way of headbox and pintle support where $t_w = (t_s + 4)$ mm
(5) Nozzle stock	Combined stresses in stock at lower bearing $\leq 92,7$ N/mm ² (9,45 kgf/mm ²) Torsional stress in upper stock $\leq 62,0$ N/mm ² (6,3 kgf/mm ²)
(6) Solepiece and strut	Bending stresses not to exceed 70,0 N/mm ² (7,1 kgf/mm ²)
Symbols	

- N_N = a numeral dependent on the nozzle requirements
- P = power transmitted to the propellers, in kW
- $(H$ = power transmitted to the propellers, in shp)
- δ_p = diameter of the propeller, in metres
- t_s = thickness of shroud plating in way of propeller tips, in mm
- t_p = thickness of plating, in mm
- t_w = thickness of webs and ring webs in way of headbox and pintle support, in mm

Note Thicknesses given are for mild steel. Reductions in thickness will be considered for certain stainless steels.

3.2 Nozzle structure

3.2.1 For basic scantlings of the structure, see *Table 13.3.1 Nozzle construction requirements*, in association with *Figure 13.3.1 Nozzle construction*.

3.2.2 The shroud plating in way of the propeller tips is to be carried well forward and aft of this position, due allowance being made on steering nozzles for the rotation of the nozzle in relation to the propeller.

3.2.3 Fore and aft webs are to be fitted between the inner and outer skins of the nozzle. Both sides of the headbox and pintle support structure are to be connected to fore and aft webs of increased thickness. For thicknesses, see *Table 13.3.1 Nozzle construction requirements*.

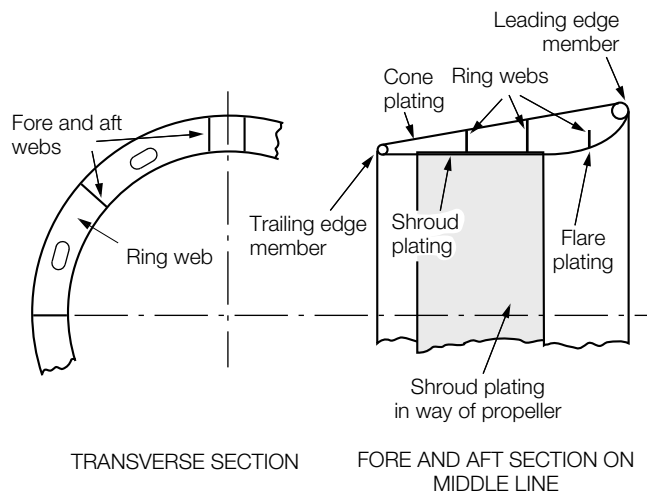

Figure 13.3.1 Nozzle construction

3.2.4 The transverse strength of the nozzle is to be maintained by the fitting of ring webs. Two ring webs are to be fitted in nozzles not exceeding 2,5 m diameter. Nozzles between 2,5 and 3,0 m in diameter are generally to have two full ring webs and a half-depth web supporting the flare plating. The number of ring webs is to be increased as necessary on nozzles exceeding 3,0 m in diameter. Where ring webs are increased in thickness in way of the headbox and pintle support structure in accordance with *Table 13.3.1 Nozzle construction requirements*, the increased thickness is to be maintained to the adjacent fore and aft web.

3.2.5 Local stiffening is to be fitted in way of the top and bottom supports which are to be integrated with the webs and ring webs. Continuity of bending strength is to be maintained in these regions.

3.2.6 Fin plating thickness should be not less than the cone plating, and the fin should be adequately reinforced. Solid fins should be not less than 25 mm thick.

3.2.7 Care is to be taken in the manufacture of the nozzle to ensure its internal preservation and watertightness. The preservation and testing are to be as required for rudders, see *Pt 3, Ch 13, 2.7 Rudder construction – Single plated* and *Table 1.9.1 Testing requirements in Pt 3, Ch 1 General*.

3.3 Nozzle stock and solepiece

3.3.1 Stresses, derived using the maximum side load on the nozzle and fin acting at the assumed centre of pressure, are not to exceed the values given in *Table 13.3.1 Nozzle construction requirements*, in both the ahead and astern conditions.

3.4 Ancillary items

3.4.1 The diameter and first moment of area about the stock axis of coupling bolts and the diameter of pintles, are to be derived from *Pt 3, Ch 13, 2.5 Rudder stock and bearings* and *Pt 3, Ch 13, 2.6 Rudder construction – Double plated*.

3.4.2 Suitable arrangements are to be provided to prevent the steering nozzle from lifting.

■ *Section 4* **Steering gear and allied systems**

4.1 General

4.1.1 For the requirements of steering gear, see *Pt 5, Ch 19 Steering Arrangements*.

■ *Section 5* **Bow and stern thrust unit structure**

5.1 Unit wall thickness

5.1.1 The wall thickness of the unit is, in general, to be in accordance with the manufacturer's practice, but is to be not less than either the thickness of the surrounding shell plating plus 10 per cent or 15 mm, whichever is greater.

5.2 Framing

5.2.1 The unit is to be framed to the same standard as the surrounding shell plating.

5.2.2 The unit is to be adequately supported and stiffened.

■ *Section 6* **Stabiliser structure**

6.1 Fin stabilisers

6.1.1 The box into which the stabilisers retract is to have perimeter plating of the same thickness as the surrounding Rule shell plating plus 2 mm, but is to be not less than 12,5 mm, and is to be stiffened to the same standard as the shell.

6.1.2 The stabiliser machinery and surrounding structure is to be adequately supported and stiffened. Where bending stresses are induced in the structure under fatigue conditions the maximum stress is not to exceed 39,0 N/mm² (4 kgf/mm²).

6.2 Stabiliser tanks

6.2.1 The general structure of the tank is to comply with the Rule requirements for deep tanks. Sloshing forces in the tank structure are to be taken into account. Where such forces are likely to be significant, the scantlings will be required to be verified by additional calculation.

■ Section 7 Equipment

7.1 General

7.1.1 To entitle a ship to the figure **1** in its character of classification, equipment in accordance with the requirements of *Table 13.7.1 Equipment requirements* is to be provided. The regulations governing the assignment of the character figure **1** for equipment are given in *Pt 1, Ch 2, 2 Character of classification and class notations*.

7.1.2 For ships intended to be operated only in suitable areas or conditions which have been agreed by the Committee, as defined in *Pt 1, Ch 2, 2.3 Class notations (hull) 2.3.6 to Pt 1, Ch 2, 2.3 Class notations (hull) 2.3.10*, equipment differing from these requirements may be approved if considered suitable for the particular service on which the ship is to be engaged, see also *Table 13.7.1 Equipment requirements*.

7.1.3 Where the Committee has agreed that anchoring and mooring equipment need not be fitted in view of the particular service of the ship, the character letter **N** will be assigned, see also *Pt 1, Ch 2, 2.2 Character symbols 2.2.2*.

Table 13.7.1 Equipment requirements

Ship type	Service	Required equipment
Cargo ships, bulk carriers, tankers, ferries, dredgers, etc. (see <i>Pt 3, Ch 13, 1.1 Application 1.1.2</i>)	Unrestricted service	(1) See <i>Pt 3, Ch 13, 7.6 Towlines and mooring lines for ships over 90 m in length 7.6.1</i> and <i>Pt 3, Ch 13, 7.6 Towlines and mooring lines for ships over 90 m in length 7.6.1</i> , using N_C
Ferries	Certain restricted Services, see <i>Pt 1, Ch 2, 2.3 Class notations (hull) 2.3.9</i>	(2) See <i>Pt 3, Ch 13, 7.6 Towlines and mooring lines for ships over 90 m in length 7.6.1</i> and <i>Pt 3, Ch 13, 7.6 Towlines and mooring lines for ships over 90 m in length 7.6.1</i> , using N_C and N_A as appropriate Mass of bower anchor $N_A = \text{one grade below } N_C$ Chain cable length and diameter $N_A = \text{one grade below } N_C$ Stream anchor may be omitted
		As per item (2), also Anchor chains Where $L < 30$ m, may be replaced with wire ropes of equal minimum breaking strength which should:

<p>Ferries</p>	<p>Specified coastal service, see Pt 1, Ch 2, 2.3 Class notations (hull) 2.3.8</p>	<p>(a) have a length 1,5 times that for chain cable required by Pt 3, Ch 13, 7.6 Towlines and mooring lines for ships over 90 m in length 7.6.1 and</p> <p>(b) have a length of Grade U2/U1 chain cable not less than 12,5 m between anchor and wire rope.</p> <p>Where $30\text{ m} \leq L \leq 40\text{ m}$ one chain cable may be replaced with wire rope meeting the requirements of $L > 40\text{ m}$. The other may be replaced with wire rope meeting the requirements of $L < 30\text{ m}$.</p> <p>Where $40\text{ m} < L \leq 90\text{ m}$, both chain cables may be replaced with wire rope of equal minimum breaking strength which should</p> <p>(a) have a length 1,5 times that for chain cable required by Pt 3, Ch 13, 7.6 Towlines and mooring lines for ships over 90 m in length 7.6.1 and</p> <p>(b) have a minimum mass per unit length of 30% that of Grade U2 chain cable required by Pt 3, Ch 13, 7.6 Towlines and mooring lines for ships over 90 m in length 7.6.1 and</p> <p>(c) have a length of Grade U2/U1 chain cable not less than 12,5 m between anchor and wire rope.</p>
<p>Dredging and reclamation craft</p>	<p>Extended protected waters service, see Pt 1, Ch 2, 2.3 Class notations (hull) 2.3.7</p>	<p>(4) See Pt 3, Ch 13, 7.6 Towlines and mooring lines for ships over 90 m in length 7.6.1 and Pt 3, Ch 13, 7.6 Towlines and mooring lines for ships over 90 m in length 7.6.1, using N_C and N_A as appropriate</p> <p>$N_A = N_C$ reduced by two grades, except for stream anchors, or mooring lines</p> <p>Stream anchor – not required if ship fitted with positioning spuds</p>
	<p>Protected waters service, see Pt 1, Ch 2, 2.3 Class notations (hull) 2.3.6</p>	<p>5) See Pt 3, Ch 13, 7.6 Towlines and mooring lines for ships over 90 m in length 7.6.1 and Pt 3, Ch 13, 7.6 Towlines and mooring lines for ships over 90 m in length 7.6.1 using N_C and N_A as appropriate</p> <p>Mass of bower anchor $N_A = 0,5N_C$</p> <p>Chain cable diameter $N_A = 0,5N_C$</p> <p>Bower anchors powered ships – two anchors</p> <p>Bower anchors unpowered (manned) ships – one anchor</p> <p>Chain cable length – greater of $2L$ m or $10,0T_D$ m, but need not exceed requirements for an ordinary cargo ship with anchors of the same mass</p> <p>Mooring lines – as required for N_C</p> <p>Wire ropes – may be substituted for chain cable on bower anchors if breaking strength $\geq 1,5$ times that of the chain cable</p>

	Unrestricted service	<p>(6) See Pt 3, Ch 13, 7.6 Towlines and mooring lines for ships over 90 m in length 7.6.1, and Notes to Table Pt 3, Ch 13, 7.6 Towlines and mooring lines for ships over 90 m in length 7.6.1 using N_C</p> <p>Anchor chains Where $L < 30$ m, may be replaced with wire ropes of equal strength. Where $30 \text{ m} \leq L \leq 40$ m, one chain cable may be replaced with wire rope of equal strength provided normal chain cable maintained for the second line</p> <p>Wire ropes of trawl winches complying with above may be used as anchor cables. Wire ropes substituted for anchor chains should</p> <p>(a) have a length 1,5 times that for chain cable required by Pt 3, Ch 13, 7.6 Towlines and mooring lines for ships over 90 m in length 7.6.1 and</p> <p>(b) have a length Grade U2/U1 of chain not less than 12,5 m between anchor and wire rope.</p> <p>Hawsers and warps – Sufficient in number and strength for proper working of the ship</p>
Tugs	Unrestricted and restricted service	<p>(7) See Pt 3, Ch 13, 7.6 Towlines and mooring lines for ships over 90 m in length 7.6.1 and Pt 3, Ch 13, 7.6 Towlines and mooring lines for ships over 90 m in length 7.6.1 using N_C except as stated below</p> <p>Stream anchor – not required</p> <p>Towlines – adequate for tug's maximum bollard pull with factor of safety $\geq 2,0$</p>
	Service restricted, see Pt 1, Ch 2, 2.3 Class notations (hull) 2.3.7 to Pt 1, Ch 2, 2.3 Class notations (hull) 2.3.10	<p>(8) See Pt 3, Ch 13, 7.6 Towlines and mooring lines for ships over 90 m in length 7.6.1 and Pt 3, Ch 13, 7.6 Towlines and mooring lines for ships over 90 m in length 7.6.1 using N_C</p> <p>Mass of bower anchor reduced to correspond to two Equipment Letters below that required for N_C</p> <p>Chain cable diameter reduced to correspond to two Equipment Letters below that required for N_C</p> <p>Anchor chains As item (3) in this Table</p>
	Protected waters service, See Pt 1, Ch 2, 2.3 Class notations (hull) 2.3.6	<p>9) See Pt 3, Ch 13, 7.6 Towlines and mooring lines for ships over 90 m in length 7.6.1 and Pt 3, Ch 13, 7.6 Towlines and mooring lines for ships over 90 m in length 7.6.1 using N_A</p> <p>Mass of bower anchor $N_A = 0,5N_C$</p> <p>Chain cable diameter $N_A = 0,5N_C$</p> <p>Chain cable length = 0,5 times length required by N_A</p> <p>Where $N_C < 90$, the requirements for anchors and chain cable will be specially considered</p> <p>Anchor chains As item (3) in this Table</p>

Offshore supply ships	Unrestricted service	<p>10) See Pt 3, Ch 13, 7.6 Towlines and mooring lines for ships over 90 m in length 7.6.1 and Pt 3, Ch 13, 7.6 Towlines and mooring lines for ships over 90 m in length 7.6.1, using N_C</p> <p>Chain cable length – increased to correspond to two Equipment and diameter and diameter Letters above that required for N_C. Need not be applied for ships with DP(AAA), DP(AA) or DP(AM) notations</p>
Manned barges and pontoons	Service restricted, see Pt 1, Pt 1, Ch 2, 2.3 Class notations (hull) 2.3.7 to Pt 1, Ch 2, 2.3 Class notations (hull) 2.3.10	(11) As item (4) in this Table
Unmanned barges and pontoons	Unrestricted service, or service restricted, see Pt 1, Ch 2, 2.3 Class notations (hull) 2.3.7 to Pt 1, Ch 2, 2.3 Class notations (hull) 2.3.10TT	<p>(12) See Pt 3, Ch 13, 7.6 Towlines and mooring lines for ships over 90 m in length 7.6.1 and Pt 3, Ch 13, 7.6 Towlines and mooring lines for ships over 90 m in length 7.6.1, using N_C and N_A as appropriate</p> <p>Anchors $L < 30$ m, no anchor need be carried</p> <p>Anchors $L \geq 30$ m, one anchor to be fitted</p> <p>Anchor cable length – greater of 40 m or $2L$ m</p> <p>(a) Unrestricted service: mass of anchors and chain cable diameters as for N_C</p> <p>(b) Protected water service, see Pt 1, Ch 2, 2.3 Class notations (hull) 2.3.6: mass of anchors and chain cable diameters, $N_A = 0,5N_C$</p> <p>(c) Service restriction, see Pt 1, Ch 2, 2.3 Class notations (hull) 2.3.7 to Pt 1, Ch 2, 2.3 Class notations (hull) 2.3.10: mass of anchor and chain cable diameter, N_A reduced to correspond to two Equipment Letters below N_C</p> <p>Mooring lines $L < 65$ m, two mooring lines to be fitted</p> <p>$L \geq 65$ m, three mooring lines to be fitted length of mooring lines to be the greater of $2L$ or 80 m, but need not exceed that for manned ships Strength of each line to be that required by NC Consideration will be given to proposals to omit anchoring equipment in association with the assignment of the character figure 1, See Pt 1, Ch 2, 2.2 Character symbols. Where $L < 65$ m consideration will be given to the omission of anchoring and mooring equipment, in which case the character letter N will be assigned in the character of classification, see Pt 1, Ch 2, 2.2 Character symbols</p>
Symbols		
<p>L = length of ship as defined in Pt 3, Ch 1, 6.1 Principal particulars</p> <p>N_A = actual equipment number to be used, if different from N_C</p> <p>N_C = calculated equipment number for ship as required by Pt 3, Ch 1, 7.1 Calculation of Equipment Number</p> <p>T_D = maximum depth at which ship is designed to dredge, in metres</p>		

7.1.4 Where the ship is intended to perform its primary designed service function only while it is anchored, moored, towed or linked, the character letter **T** will be assigned, see also Pt 1, Ch 2, 2.2 Character symbols 2.2.2.

7.1.5 For classification purposes, the character figure **1**, or either of the character letters **N** or **T**, is to be assigned.

7.2 Anchors

7.2.1 Anchors are to be of an approved design. The design of all anchor heads is to be such as to minimise stress concentrations, and in particular, the radii on all parts of cast anchor heads are to be as large as possible, especially where there is considerable change of section.

7.2.2 Anchors which must be specially laid the right way up, or which require the fluke angle or profile to be adjusted for varying types of sea bed, will not generally be approved for normal ship use, but may be accepted for offshore units, floating cranes, etc. In such cases suitable tests may be required.

7.2.3 The mass of each bower anchor given in *Table 13.7.2 Equipment - Bower anchors and chain cables* is for anchors of equal mass. The masses of individual anchors may vary by ± 7 per cent of the masses given in the Table, provided that the total mass of the anchors is not less than would have been required for anchors of equal mass.

7.2.4 The mass of the head, including pins and fittings, of an ordinary stockless anchor is to be not less than 60 per cent of the total mass of the anchor.

7.2.5 When stocked bower or stream anchors are to be used, the mass 'ex-stock' is to be not less than 80 per cent of the mass given in *Table 13.7.2 Equipment - Bower anchors and chain cables* for ordinary stockless bower anchors. The mass of the stock is to be 25 per cent of the total mass of the anchor, including the shackle, etc. but excluding the stock.

7.3 High holding power anchors

7.3.1 When high holding power anchors are used as bower anchors, the mass of each such anchor may be 75 per cent of the mass given in the Table for ordinary stockless bower anchors.

7.3.2 Anchor designs for which approval is sought as high holding power anchors are to be tested at sea to show that they have holding powers of at least twice those of approved standard stockless anchors of the same mass.

7.3.3 If approval is sought for a range of sizes, then at least two sizes are to be tested. The smaller of the two anchors is to have a mass not less than one-tenth of that of the larger anchor, and the larger of the two anchors tested is to have a mass not less than one-tenth of that of the largest anchor for which approval is sought.

7.3.4 High holding power anchors are to be of a design that will ensure that the anchors will take effective hold of the sea bed without undue delay and will remain stable, for holding forces up to those required by *Pt 3, Ch 13, 7.3 High holding power anchors 7.3.2*, irrespective of the angle or position at which they first settle on the sea bed when dropped from a normal type of hawse pipe. In case of doubt, a demonstration of these abilities may be required.

7.3.5 The test should normally be carried out from a tug or other suitable vessel, and the pull measured by dynamometer or derived from recently verified curves of tug rev/min against bollard pull. The tests are to be conducted on no fewer than three different types of bottom, which should normally be soft mud or silt, sand or gravel, and hard clay or similarly compacted material. A scope of 10 is recommended for the anchor cable, but in no case should a scope of less than six be used. The same scope is to be used for the anchor for which approval is sought and the anchor that is being used for comparison purposes.

7.4 Chain cables

7.4.1 Chain cables may be of mild steel, special quality steel or extra quality steel in accordance with the requirements of *Ch 10 Equipment for Mooring and Anchoring* and are to be graded in accordance with *Table 13.7.5 Chain cable steel grades*.

7.4.2 Grade U1 material having a tensile stress of less than 400 N/mm² (41 kgf/cm²) is not to be used in association with high holding power anchors. Grade U3 material is to be used only for chain 20,5 mm or more in diameter.

7.4.3 Where stream anchors are used in association with chain cable, this cable may be either stud link or short link.

7.4.4 The form and proportion of links and shackles are to be in accordance with *Ch 10 Equipment for Mooring and Anchoring* of the Rules for Materials.

7.4.5 Where Owners require equipment for anchoring at depths greater than 82,5 m, it is their responsibility to specify the appropriate total length of the chain cable required for this purpose. In such cases, consideration can be given to dividing the chain cable into two unequal lengths.

7.5 Towlines and mooring lines for ships under 90 m in length

7.5.1 **Ships under 90 m** require mooring lines as specified in *Table 13.7.3 Equipment - Stream anchors, stream wires, towlines and mooring lines*. Towlines are not required for classification and the details given in the Table are for guidance purposes only. Mooring lines may be of wire, natural fibre or synthetic fibre. The diameter, construction and specification of wire or natural

fibre mooring lines are to comply with the requirements of *Ch 10 Equipment for Mooring and Anchoring* of the Rules for Materials. Where it is proposed to use synthetic fibre ropes, the size and construction will be specially considered.

7.6 Towlines and mooring lines for ships over 90 m in length

7.6.1 **Ships 90 m and over** in length do not require towlines and mooring lines as a classification item. It is recommended, however, that the number, length and strength of mooring lines provided on board the ship not be less than that given in *Table 13.7.3 Equipment - Stream anchors, stream wires, towlines and mooring lines*.

Table 13.7.2 Equipment - Bower anchors and chain cables

Equipment number		Equipment Letter	Stockless bower anchors		Stud link chain cables for bower anchors			
Exceeding	Not Exceeding		Number	Mass of anchor, in kg	Total length, in metres	Diameter, in mm		
						Mild steel (Grade 1 or U1)	Special quality steel (Grade U2)	Extra special quality steel (Grade U3)
50	70	A	2	180	220	14	12,5	-
70	90	B	2	240	220	16	14	-
90	110	C	2	300	247,5	17,5	16	-
110	130	D	2	360	247,5	19	17,5	-
130	150	E	2	420	275	20,5	17,5	-
150	175	F	2	480	275	22	19	-
175	205	G	2	570	302,5	24	20,5	-
205	240	H	2	660	302,5	26	22	20,5
240	280	I	2	780	330	28	24	22
280	320	J	2	900	357,5	30	26	24
320	360	K	2	1020	357,5	32	28	24
360	400	L	2	1140	385	34	30	26
400	450	M	2	1290	385	36	32	28
450	500	N	2	1440	412,5	38	34	30
500	550	O	2	1590	412,5	40	34	30
550	600	P	2	1740	440	42	36	32
600	600	Q	2	1920	440	44	38	34
660	720	R	2	2100	440	46	40	36
720	780	S	2	2280	467,5	48	42	36
780	840	T	2	2460	467,5	50	44	38
840	910	U	2	2640	467,5	52	46	40
910	980	V	2	2850	495	54	48	42
980	1060	W	2	3060	495	56	50	44
1060	1140	X	2	3300	495	58	50	46
1140	1220	Y	2	3540	522,5	60	52	46
1220	1300	Z	2	3780	522,5	62	54	48
1300	1390	A†	2	4050	522,5	64	56	50
1390	1480	B†	2	4320	550	66	58	50
1480	1570	C†	2	4590	550	68	60	52
1570	1670	D†	2	4890	550	70	62	54
1670	1790	E†	2	5250	577,5	73	64	56
1790	1930	F†	2	5610	577,5	76	66	58

Ship Control Systems

Part 3, Chapter 13

Section 7

1930	2080	G†	2	6000	577,5	78	68	60
2080	2230	H†	2	6450	605	81	70	62
2230	2380	I†	2	6900	605	84	73	64
2380	2530	J†	2	7350	605	87	76	66
2530	2700	K†	2	7800	632,5	90	78	68
2700	2870	L†	2	8300	632,5	92	81	70
2870	3040	M†	2	8700	632,5	95	84	73
3040	3210	N†	2	9300	660	97	84	76
3210	3400	O†	2	9900	660	100	87	78
3400	3600	P†	2	10500	660	102	90	78
3600	3800	Q†	2	11100	687,5	105	92	81
3800	4000	R†	2	11700	687,5	107	95	84
4000	4200	S†	2	12300	687,5	111	97	87
4200	4400	T†	2	12900	715	114	100	87
4400	4600	U†	2	13500	715	117	102	90
4600	4800	V†	2	14100	715	120	105	92
4800	5000	W†	2	14700	742,5	122	107	95
5000	5200	X†	2	15400	742,5	124	111	97
5200	5500	Y†	2	16100	742,5	127	111	97
5500	5800	Z†	2	16900	742,5	130	114	100
5800	6100	A*	2	17800	742,5	132	117	102
6100	6500	B*	2	18800	742,5	-	120	107
6500	6900	C*	2	20000	770	-	124	111
6900	7400	D*	2	21500	770	-	127	114
7400	7900	E*	2	23000	770	-	132	117
7900	8400	F*	2	24500	770	-	137	122
8400	8900	G*	2	26000	770	-	142	127
8900	9400	H*	2	27500	770	-	147	132
9400	10000	I*	2	29000	770	-	152	132
10000	10700	J*	2	31000	770	-	157	137
10700	11500	K*	2	33000	770	-	157	142
11500	12400	L*	2	35500	770	-	162	147
12400	13400	M*	2	38500	770	-	-	152
13400	14600	N*	2	42000	770	-	-	157
14600	16000	O*	2	46000	770	-	-	162

Table 13.7.3 Equipment - Stream anchors, stream wires, towlines and mooring lines

Equipment number		Equipment Letter	Mass of stockles stream anchor, in kg	Stream wire or chain			Towline ⁽¹⁾		Mooring lines		
Exceeding	Not exceeding			Minimum length in metres	Minimum breaking strength, in kN (tonne-f)		Minimum length in metres	Minimum breaking strength, in kN	Number	Minimum length of each line, in metres	Minimum breaking strength, in kN (tonne-f)
50	70	A	60	80	64,7	(6,60)	180	98	3	80	34
70	90	B	80	85	73,5	(7,50)	180	98	3	100	37
90	110	C	100	85	81,4	(8,30)	180	98	3	110	39
110	130	D	120	90	89,2	(9,10)	180	98	3	110	44
130	150	E	140	90	98,1	(10,00)	180	98	3	120	49
150	175	F	165	90	107,9	(11,00)	180	98	3	120	54
175	205	G	190	90	117,7	12,00)	180	112	3	120	59
205	240	H	-	-	-	-	180	129	4	120	64
240	280	I	-	-	-	-	180	150	4	120	69
280	320	J	-	-	-	-	180	174	4	140	74
320	360	K	-	-	-	-	180	207	4	140	78
360	400	L	-	-	-	-	180	224	4	140	88
400	450	M	-	-	-	-	180	250	4	140	98
450	500	N	-	-	-	-	180	277	4	140	108
500	550	O	-	-	-	-	190	306	4	160	123
550	600	P	-	-	-	-	190	338	4	160	132
600	660	Q	-	-	-	-	190	370	4	160	147
660	720	R	-	-	-	-	190	406	4	160	157
720	780	S	-	-	-	-	190	441	4	170	172
780	840	T	-	-	-	-	190	479	4	170	186
840	910	U	-	-	-	-	190	518	4	170	201
910	980	V	-	-	-	-	190	559	4	170	216
980	1060	W	-	-	-	-	200	603	4	180	230
1060	1140	X	-	-	-	-	200	647	4	180	250
1140	1220	Y	-	-	-	-	200	691	4	180	270
1220	1300	Z	-	-	-	-	200	738	4	180	284
1300	1390	A†	-	-	-	-	200	786	4	180	309
1390	1480	B†	-	-	-	-	200	836	4	180	324
1480	1570	C†	-	-	-	-	220	888	5	190	324
1570	1670	D†	-	-	-	-	220	941	5	190	333

Ship Control Systems

Part 3, Chapter 13

Section 7

1670	1790	E†	-	-	-	-	220	1024	5	190	353
1790	1930	F†	-	-	-	-	220	1109	5	190	378
1930	2080	G†	-	-	-	-	220	1168	5	190	402
2080	2230	H†	-	-	-	-	240	1259	5	200	422
2230	2380	I†	-	-	-	-	240	1356	5	200	451
2380	2530	J†	-	-	-	-	240	1453	5	200	480
2530	2700	K†	-	-	-	-	260	1471	6	200	480
2700	2870	L†	-	-	-	-	260	1471	6	200	490
2870	3040	M†	-	-	-	-	260	1471	6	200	500
3040	3210	N†	-	-	-	-	280	1471	6	200	520
3210	3400	O†	-	-	-	-	280	1471	6	200	554
3400	3600	P†	-	-	-	-	280	1471	6	200	588
3600	3800	Q†	-	-	-	-	300	1471	6	200	618
3800	4000	R†	-	-	-	-	300	1471	6	200	647
4000	4200	S†	-	-	-	-	300	1471	7	200	647
4200	4400	T†	-	-	-	-	300	1471	7	200	657
4400	4600	U†	-	-	-	-	300	1471	7	200	667
4600	4800	V†	-	-	-	-	300	1471	7	200	677
4800	5000	W†	-	-	-	-	300	1471	7	200	686
5000	5200	X†	-	-	-	-	300	1471	8	200	686
5200	5500	Y†	-	-	-	-	300	1471	8	200	696
5500	5800	Z†	-	-	-	-	300	1471	8	200	706
5800	6100	A*	-	-	-	-	300	1471	9	200	706
6100	6500	B*	-	-	-	-	-	-	9	200	716
6500	6900	C*	-	-	-	-	-	-	9	200	726
6900	7400	D*	-	-	-	-	-	-	10	200	726
7400	7900	E*	-	-	-	-	-	-	11	200	726
7900	8400	F*	-	-	-	-	-	-	11	200	736
8400	8900	G*	-	-	-	-	-	-	12	200	736
8900	9400	H*	-	-	-	-	-	-	13	200	736
9400	10000	I*	-	-	-	-	-	-	14	200	736
10000	10700	J*	-	-	-	-	-	-	15	200	736
10700	11500	K*	-	-	-	-	-	-	16	200	736
11500	12400	L*	-	-	-	-	-	-	17	200	736
12400	13400	M*	-	-	-	-	-	-	18	200	736
13400	14600	N*	-	-	-	-	-	-	19	200	736
14600	16000	O*	-	-	-	-	-	-	21	200	736

Note 1. Towline specified for guidance only, see *Pt 3, Ch 13, 7.5 Towlines and mooring lines for ships under 90 m in length 7.5.1*. For tugs see *Table 13.7.1 Equipment requirements* item (6).

Note 2. The rope used for stream wire is to be constructed of not less than 72 wires, made up into six strands.

Note 3. Wire ropes used for tows and mooring lines are generally to be of a flexible construction with not less than: 144 wires in six strands with seven fibre cores for strengths up to 490 kN (50 tonne-f). 222 wires in six strands with one fibre core for strengths exceeding 490 kN (50 tonne-f). The wires laid round the fibre centre of each strand are to be made up in not less than two layers.

Note 4. Wire ropes for tows and mooring lines used in association with mooring winches (on which the rope is stored on the winch drum) are to be of suitable construction.

Note 5. The lengths of individual mooring lines may be reduced by up to seven per cent of the Table length, provided that the total length of mooring lines is not less than would have resulted had all lines been of equal length.

Note

6. Tests. See *Ch 10 Equipment for Mooring and Anchoring* for wire ropes and fibre ropes respectively.

Note 7. For individual mooring lines with breaking strength above 490 kN the breaking strength may be reduced with corresponding increase of the number of the mooring lines and vice versa, provided that the total breaking strength of all lines aboard the ship is not less than the Rule value. In this case the number of lines is not to be less than 6 and no one line is to have a strength of less than 490 kN.

Note 8. Where wire rope is used in lieu of chain cable for anchoring, see *Table 13.7.1 Equipment requirements*, galvanised wire rope with an independent wire core in accordance with *Ch 10, 6 Steel wire ropes* of the Rules for Materials is to be used. Wire rope terminal fittings are to comply with an acceptable code or standard. The strength of terminations, connecting fittings, shackles or links is not to be less than that of the anchor line.

Table 13.7.4 Trawlers, stern trawlers and fishing vessels

Equipment number		Stockless bower anchors		Stud link chain cables for bower anchors		
Exceeding	Not exceeding	Number	Mass of anchor in kg	Total length in metres	Diameter, in mm	
					Mild steel (Grade 1 or U1)	Special quality steel (Grade U2)
50	60	2	120	192,5	12,5	–
60	70	2	140	192,5	12,5	–
70	80	2	160	220,0	14,0	12,5
80	90	2	180	220,0	14,0	12,5
90	100	2	210	220,0	16,0	14,0
100	110	2	240	220,0	16,0	14,0
110	120	2	270	247,5	17,5	16,0
120	130	2	300	247,5	17,5	16,0
130	140	2	340	275,0	19,0	17,5
140	150	2	390	275,0	19,0	17,5
150	175	2	480	275,0	22,0	19,0
175	205	2	570	302,5	24,0	20,5
205	240	2	660	302,5	26,0	22,0
240	280	2	780	330,0	28,0	24,0
280	320	2	900	357,5	30,0	26,0
320	360	2	1020	357,5	32,0	28,0
360	400	2	1140	385,0	34,0	30,0
400	450	2	1290	385,0	36,0	32,0
450	500	2	1440	412,5	38,0	34,0
500	550	2	1590	412,5	40,0	34,0
550	600	2	1740	440,0	42,0	36,0
600	660	2	1920	440,0	44,0	38,0
660	720	2	2100	440,0	46,0	40,0

Table 13.7.5 Chain cable steel grades

Grade	Material	Tensile strength	
		N/mm ²	(kgf/mm ²)
U1	Mild steel	300 - 490	(31 - 50)
U2 (a)	Special quality steel (wrought)	490 - 690	(50 - 70)
U2 (b)	Special quality steel (cast)	490 - 690	(50 - 70)
U3	Extra special quality steel	690 min.	(70 min.)

7.6.2 For ease of handling, fibre ropes are to be not less than 20 mm in diameter. All ropes having breaking strengths in excess of 736,0 kN (75,0 tonne-f) and used in normal mooring operations are to be handled by, and stored on, suitably designed winches. Alternative methods of storing should give due consideration to the difficulties experienced in manually handling ropes having breaking strengths in excess of 490,0 kN (50,0 tonne-f).

7.6.3 Mooring winches should be fitted with drum brakes, the strength of which is sufficient to prevent unreeling of the mooring line when the rope tension is equal to 80 per cent of the breaking strength of the rope as fitted on the first layer on the winch drum.

■ **Section 8**
Windlass design and testing

8.1 Windlass design

8.1.1 A windlass of sufficient power and suitable for the size of chain is to be fitted to the ship. Where Owners require equipment significantly in excess of Rule requirements, it is their responsibility to specify increased windlass power.

8.1.2 The following performance criteria are to be used as a design basis for the windlass:

(a) The windlass is to have sufficient power to exert a continuous duty pull over a period of 30 minutes of:

- for specified design anchorage depths up to 82,5 m:

Chain cable grade	Duty pull, P , in N (kgf)
U1	$37,5d_c^2$ ($3,82d_c^2$)
U2	$42,5d_c^2$ ($4,33d_c^2$)
U3	$47,5d_c^2$ ($4,84d_c^2$)

- for specified design anchorage depths greater than 82,5 m:

$$P_1 = P + (D_a - 82,5) 0,27d_c^2 \text{N}$$

$$\left[P_1 = P + (D_a - 82,5) 0,0275d_c^2 \text{kgf} \right]$$

where

- = d_c is the chain diameter, in mm
- = D_a is the specified design anchorage depth, in metres
- = P is the duty pull for anchorage depth up to 82,5 m
- = P_1 is the duty pull for anchorage depths greater than 82,5 m.

(b) The windlass is to have sufficient power to exert, over a period of at least two minutes, a pull equal to the greater of:

(i) short term pull:

1,5 times the continuous duty pull as defined in Pt 3, Ch 13, 8.1 Windlass design 8.1.2, or

(ii) anchor breakout pull:

$$12,18W_a + \frac{7,0L_c d_c^2}{100} \text{N}$$

$$\left(1,24W_a + \frac{7,1L_c d_c^2}{1000} \text{kgf} \right)$$

where:

L_c = is the total length of chain cable on board, in metres, as given by *Table 13.7.2 Equipment - Bower anchors and chain cables*

W_a = is the mass of bower anchor (kg) as given in *Table 13.7.2 Equipment - Bower anchors and chain cables*.

(c) The windlass, with its braking system in action and in conditions simulating those likely to occur in service, is to be able to withstand, without permanent deformation or brake slip, a load, applied to the cable, given by:

$$K_b d_c^2 (44 - 0,08d_c) N$$

$$(K_b d_c^2 (44 - 0,08d_c) \text{ kgf})$$

where K_b is given in *Table 13.8.1 Values of K_b* .

The performance criteria are to be verified by means of shop tests in the case of windlasses manufactured on an individual basis. Windlasses manufactured under LR's *Type Approval Scheme for Marine Engineering Equipment* will not require shop testing on an individual basis.

Table 13.8.1 Values of K_b

Cable grade	K_b	
	Windless used in conjunction with chain stopper	Chain stopper not fitted
	N (kgf)	N (kgf)
U1	4,41 (0,45)	7,85 (0,8)
U2	6,18 (0,63)	11,0 (1,12)
U3	8,83 (0,9)	15,7 (1,6)

8.1.3 Calculations for torque transmitting components are to be based on 1500 hours of operation with a nominal load spectrum factor of $K_m = 1,0$. Alternatively unlimited hours with $K_m = 0,8$ can be applied.

8.1.4 Where the available input torque exceeds the torque required for anchor breakout then torque overload protection is to be fitted.

8.1.5 An arrangement to release the anchor and chain in the event of windlass power failure is to be provided.

8.1.6 The design of the windlass is to be such that the following requirements or equivalent arrangements will minimise the probability of the chain locker or forecable being flooded in bad weather:

- (a) a weathertight connection can be made between the windlass bedplate, or its equivalent, and the upper end of the chain pipe, and
- (b) access to the chain pipe is adequate to permit the fitting of a cover or seal, of sufficient strength and proper design, over the chain pipe while the ship is at sea.

8.2 Calculations

8.2.1 Where shop testing is not possible and Type Approval has not been obtained, calculations demonstrating compliance with *Pt 3, Ch 13, 8.1 Windlass design 8.1.2* are to be submitted together with detailed plans and an arrangement plan showing the following components:

- Shafting
- Gearing
- Brakes
- Clutches

8.2.2 The maximum stress from load cases stated in *Table 13.8.2 Design load cases for windlass and chainstopper* are not to exceed the limits stated in *Table 13.8.3 Permissible stress for design load cases*.

Table 13.8.2 Design load cases for windlass and chainstopper

Load case	Condition	Note
1	Continuous pull	See Pt 3, Ch 13, 8.1 Windlass design 8.1.2
2	Over load pull	See Pt 3, Ch 13, 8.1 Windlass design 8.1.2
3	Brake holding load	See Pt 3, Ch 13, 8.1 Windlass design 8.1.2

Table 13.8.3 Permissible stress for design load cases

Stress	Load case	
	1 and 2	3
	Permissible stress	
Tension	0,8Y	0,9Y
Compression or bending	0,8Y	0,9Y
Shear	0,7Y	0,7Y
Combined	0,85Y	0,9Y

Note 1. Where a component is subjected to axial tensile, axial compressive, bending or shear stress, F_c is to be calculated in the normal manner.

Note 2. Where a component is subjected to a combination of co-existent stresses, F_c is the combined stress which is to be calculated as follows: Combined bending and tension $F_c = 1,25f_c + f_{bt}$ Combined bending and compression $F_c = f_c + f_{bc}$ Combined bending, tension and shear $F_c = \sqrt{(1,25f_t + f_{bt})^2 + 3f_q^2}$ Combined bending, compression and shear $F_c = \sqrt{(f_c + f_{bc})^2 + 3f_q^2}$

= where

f_t = is the calculated axial tensile stress

f_c = is the calculated axial compressive stress

f_{bt} = is the calculated maximum tensile stress due to bending about both principal axes

f_{bc} = is the calculated maximum compressive stress due to bending about both principal axes

f_q = is the calculated shear stress

Y = is the specified 0,2 per cent proof stress for the material

8.2.3 The following criteria are to be used for gearing design:

- (a) Torque is to be based on the performance criteria specified in Pt 3, Ch 13, 8.1 Windlass design 8.1.2.
- (b) The use of an equivalent torque, T_{eq} , for dynamic strength calculations is acceptable but the derivation is to be submitted to LR for consideration.
- (c) The application factor for dynamic strength calculation, K_A , is to be 1,15.
- (d) Calculations are to be based on 1500 hours of operation.
- (e) The static torque is to be $1,5 \times T_n$ where T_n is the nominal torque.
- (f) The minimum factors of safety for load capacity of spur and helical gears, as derived using ISO 6336 or a relevant National or International standard acceptable to LR, are to be 1,5 for bending stress and 0,6 for contact stress.

8.2.4 Keyways are to be designed to a relevant National or International standard acceptable to LR.

8.2.5 The maximum stress in brake components is not to exceed the permissible stress stated in Table 13.8.3 Permissible stress for design load cases.

8.3 Control arrangements

8.3.1 All control devices are to be capable of being controlled from readily accessible positions and protected against unintentional operation.

8.3.2 The maximum travel of the levers is not to exceed 600 mm if movable in one direction only, or 300 mm to either side from a central position if movable in both directions. They are to move toward the right when hauling and toward the left when paying out. Alternatively, they are to move backward when hauling and forward when paying out.

8.3.3 Wherever practical, the lever is to move in the direction of the intended movement.

8.3.4 For lever-operated brakes, the brake is to engage when the lever is pulled and disengage when the lever is pushed. The physical effort on the brake for the operator is not to exceed 160 N.

8.3.5 For pedal-operated brakes the maximum travel is not to exceed 250 mm and the physical effort for the operator is not to exceed 320 N.

8.3.6 The handwheel or crankhandle is to actuate the brake when turned clockwise and release it when turned counterclockwise. The physical effort for the operator is not to exceed 250 N for speed regulation and 500 N at any moment.

8.3.7 When not provided with automatic sequential control, separate push-buttons are to be provided for each direction of operation.

8.3.8 The push-buttons are to actuate the machinery when depressed and stop and effectively brake the machinery when released.

8.3.9 The above mentioned individual push-buttons may be replaced by two 'start' and 'stop' push-buttons.

8.3.10 Control systems, whether electric, pneumatic or hydraulic, are to comply with the general requirements of *Pt 6, Ch 1, 2 Essential features for control, alarm and safety systems*.

8.4 Maintenance arrangements

8.4.1 Access is to be provided for inspection of reduction gears, bearings, brakes, etc.

8.4.2 Accessible manual lubrication points, including nipples, are to be provided for both for oil and grease, as applicable.

8.4.3 Gear-boxes are to be provided with adequate access arrangements for monitoring and replacing oil.

8.5 Protection arrangements

8.5.1 Where applicable, moving parts of windlass machinery are to be provided with suitable railings and/or guards to prevent injury to personnel.

8.5.2 Protection is to be provided for preventing persons from coming into contact with surfaces having temperatures over 50°C.

8.5.3 Steel surfaces not protected by lubricant are to be protected by a coating in accordance with the requirements of a relevant National or International Standard acceptable to LR.

8.5.4 For arrangements of power transmission systems and relief requirements see *Pt 5, Ch 14, 9.1 General*.

8.6 Marking and identification

8.6.1 Controls are to be permanently marked for identification, unless their functions are readily apparent. If required, instructions are to be permanently marked and readily visible.

8.7 Testing and acceptance

8.7.1 During trials on board ship, the windlass is to be shown to be capable of:

- (a) for all specified design anchorage depths: raising the anchor from a depth of 82,5 m to a depth of 27,5 m at a mean speed of 9 m/min; and
- (b) for specified design anchorage depths greater than 82,5 m: in addition to (a), raising the anchor from the specified design anchorage depth to a depth of 82,5 m at a mean speed of 3 m/min.

Where the depth of water in the trial area is inadequate, suitable equivalent simulating conditions will be considered as an alternative. Following trials, the ship will be eligible to be assigned a descriptive note **specified design anchorage depth . . . metres**, which will be entered in column 6 of the *Register Book*.

8.7.2 Windlass performance characteristics specified in *Pt 3, Ch 13, 8.1 Windlass design 8.1.2* and *Pt 3, Ch 13, 8.7 Testing and acceptance 8.7.1* are based on the following assumptions:

- (a) one cable lifter only is connected to the drive shaft;
- (b) continuous duty and short term pulls are measured at the cable lifter;
- (c) brake tests are carried out with the brakes fully applied and the cable lifter declutched;
- (d) the probability of declutching a cable lifter from the motor with its brake in the off position is minimised;
- (e) hawse pipe efficiency assumed to be 70 per cent.

8.8 Winch design and testing

8.8.1 A winch of sufficient power and suitable for the size of wire rope and chain cable is to be fitted to the ship. Where owners require equipment significantly in excess of Rule requirements, it is their responsibility to specify increased winching power.

8.8.2 The requirements of *Pt 3, Ch 13, 8.1 Windlass design 8.1.2*, *Pt 3, Ch 13, 8.2 Calculations 8.2.1* and *Pt 3, Ch 13, 8.7 Testing and acceptance 8.7.1* respectively are to be applied as performance criteria for winches assuming an equivalent U2 Grade chain cable diameter and Rule length for the same equipment letter. When applying the requirements of *Pt 3, Ch 13, 8.1 Windlass design 8.1.2* the factor K_b is to be taken as specified for when a chain stopper is not fitted.

8.9 Testing of equipment

8.9.1 All anchors and chain cables are to be tested at establishments and on machines recognised by the Committee and under the supervision of LR's Surveyors or other Officers recognised by the Committee, and in accordance with *Ch 10 Equipment for Mooring and Anchoring* of the Rules for Materials.

8.9.2 Test certificates showing particulars of weights of anchors, or size and weight of cable and of the test loads applied are to be furnished. These certificates are to be examined by the Surveyors when the anchors and cables are placed on board the ship.

8.9.3 Steel wire and fibre ropes are to be tested as required by *Ch 10 Equipment for Mooring and Anchoring* of the Rules for Materials.

8.9.4 For holding power testing requirements relating to high holding power anchors, see *Ch 10, 1.7 Super high holding power (SHHP) anchors* of the Rules for Materials.

8.10 Structural requirements associated with anchoring

8.10.1 The windlass or winch is to be efficiently bedded and secured to the deck. The thickness of the deck in way of the windlass or winch is to be increased, and adequate stiffening is to be provided, to the Surveyor's satisfaction. The structural design integrity of the bedplate is the responsibility of the Shipbuilder and windlass or winch manufacturer.

8.10.2 An easy lead of the cables from the windlass to the anchors and chain lockers is to be arranged. Where cables pass over or through stoppers, these stoppers are to be manufactured from ductile material and be designed to minimise the probability of damage to, or snagging of, the cable. They are to be capable of withstanding without permanent deformation a load equal to 80 per cent of the Rule breaking load of the cable passing over them.

8.10.3 Hawse pipes and anchor pockets are to be of ample thickness and of a suitable size and form to house the anchors efficiently, preventing, as much as practicable, slackening of the cable or movements of the anchor being caused by wave action. The shell plating and framing in way of the hawse pipes are to be reinforced as necessary. Reinforcing is also to be arranged in way of those parts of bulbous bows liable to be damaged by anchors or cables. Substantial chafing lips are to be provided at shell and deck. These are to have sufficiently large, radiused faces to minimise the probability of cable links being subjected to high bending stresses. Alternatively, roller fairleads of suitable design may be fitted. Where unpocketed rollers are used, it is recommended that the roller diameter be not less than eleven times the chain diameter. Where hawse pipes are not fitted, alternative arrangements will be specially considered.

8.10.4 The chain locker is to be of a capacity and depth adequate to provide an easy direct lead for the cable into the chain pipes, when the cable is fully stowed. Chain or spurling pipes are to be of suitable size and provided with chafing lips. The port and starboard cables are to be separated by a division in the locker.

8.10.5 Where means of access is provided to the chain locker it is to be closed by a substantial cover and secured by closely spaced bolts. Where a means of access to spurling pipes or cable lockers is located below the weather deck, the access cover and its securing arrangements are to be in accordance with ISO 5894-1999, or an equivalent National Standard acceptable to LR, recognised standards or equivalent for watertight manhole covers. Butterfly nuts and/or hinged bolts are prohibited as the securing mechanism for the access cover.

8.10.6 Chain lockers and spurling pipes are to be watertight up to the exposed weather deck and the space is to be efficiently drained. However, bulkheads between separate chain lockers, or which form a common boundary of chain lockers, need not be watertight.

8.10.7 Spurling pipes are to be provided with permanently attached closing appliances to minimise water ingress. Examples of acceptable arrangements are:

- (a) steel plates with cutouts to accommodate chain links, or
- (b) canvas hoods with a lashing arrangement that maintains the cover in the secured position.

8.10.8 Provision is to be made for securing the inboard ends of the cables to the structure. This attachment should have a working strength of not less than 63,7 kN (6,5 tonne-f) or 10 per cent of the breaking strength of the chain cable, whichever is the greater, and the structure to which it is attached is to be adequate for this load. Attention is drawn to the advantages of arranging that the cable may be slipped from an accessible position outside the chain cable locker. The proposed arrangement for slipping the chain cable, if constructed outside the chain locker, must be made watertight.

8.10.9 Satisfactory arrangements are to be made for the stowage and working of the stream anchor, if provided.

8.10.10 On dredging and reclamation craft the following are to be complied with:

- (a) On unpowered ships, the windlass may be hand operated.
- (b) On split type vessels, the arrangements are to be such that jamming of the anchor cable during opening and closing operations of the hull will not occur.

8.10.11 When wire rope instead of chain is used for the anchor cable, it is to be stored on a suitably designed drum or reel. Fairleads intended for use with wire rope cable are to be designed to minimise wear and to avoid kinking or other damage occurring to the rope. Fairleads should, in general, be fitted with rollers having a diameter not less than eleven times the diameter of the anchor cable or as specified/ recommended by the rope manufacturer.

8.11 Structural requirements for windlasses on exposed fore decks

8.11.1 Windlasses located on the exposed deck over the forward 0,25L of the rule length, of ships of sea-going service of length 80 m or more, where the height of the exposed deck in way of the item is less than 0,1L or 22 m above the summer load waterline, whichever is the lesser, are to comply with the following requirements. Where mooring winches are integral with the anchor windlass, they are to be considered as part of the windlass.

8.11.2 The following pressures and associated areas are to be applied, see *Figure 13.8.1 Windlass loading*:

- 200 kN/m² normal to the shaft axis and away from the forward perpendicular, over the projected area in this direction;
- 150 kN/m² parallel to the shaft axis and acting both inboard and outboard separately, over the multiple of f times the projected area in this direction;

where

$$f = 1 + B/H, \text{ but not greater than } 2,5$$

B = width of windlass measured parallel to the shaft axis, in metres

H = overall height of windlass, in metres.

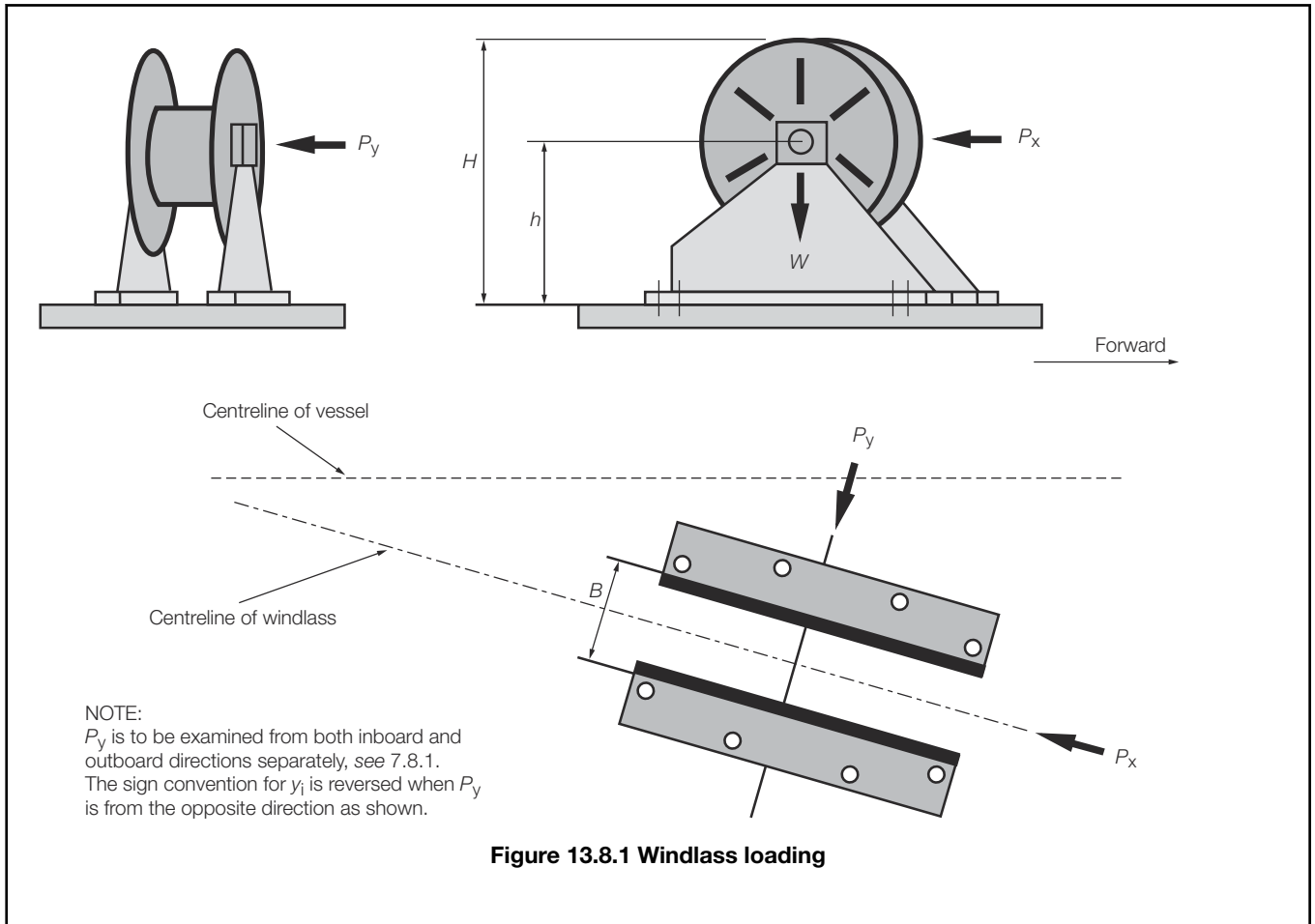

8.11.3 Forces in the bolts, chocks and stoppers securing the windlass to the deck are to be calculated. The windlass is supported by N bolt groups, each containing one or more bolts, see Figure 13.8.2 Direction of forces and weight.

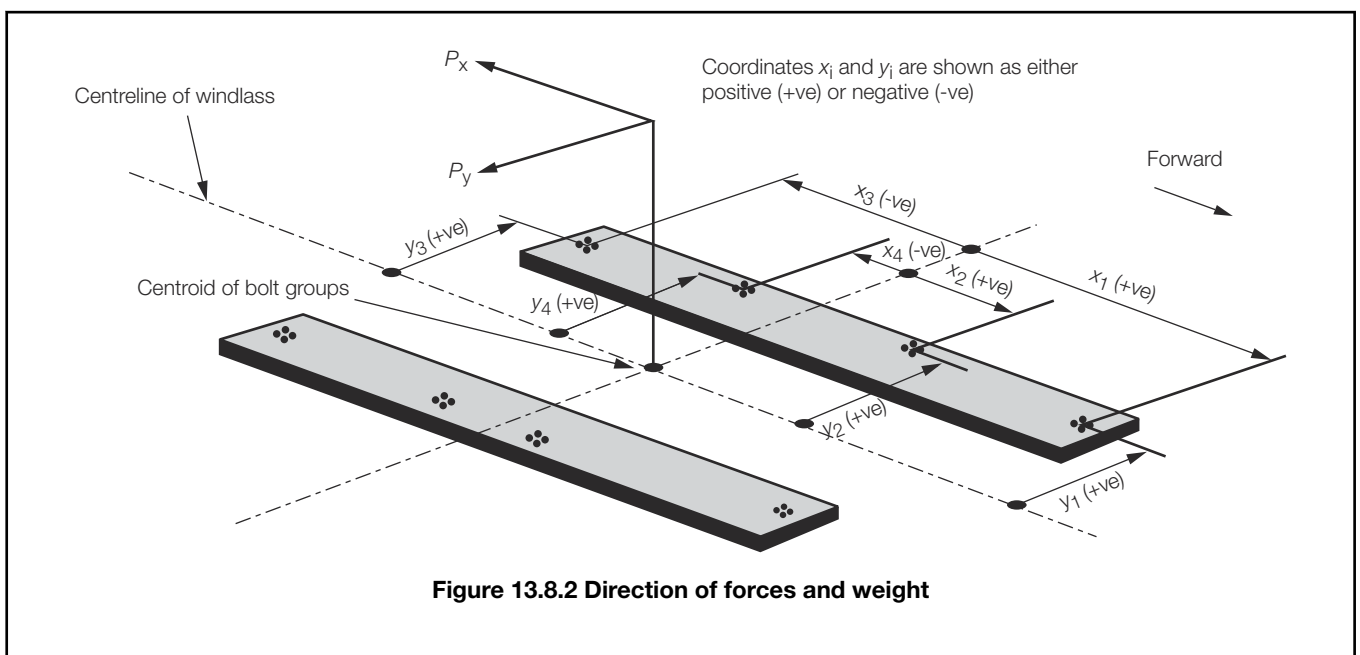

8.11.4 The axial force R_i in bolt group (or bolt) i , positive in tension, may be calculated from:

$$R_{xi} = P_x h x_i A_i / I_x \text{ in kN}$$

$$R_{yi} = P_y h y_i A_i / I_y \text{ in kN, and}$$

$$R_i = R_{xi} + R_{yi} - R_{si} \text{ in kN}$$

where

P_x = force acting normal to the shaft axis, in kN

P_y = force acting parallel to the shaft axis, either inboard or outboard whichever gives the greater force in bolt group i , in kN

h = shaft height above the windlass mounting, in cm

x_i, y_i = x and y coordinates of bolt group i from the centroid of all N bolt groups, positive in the direction opposite to that of the applied force, in cm

A_i = cross sectional area of all bolts in group i , in cm^2

$I_x = \Sigma A_i x_i^2$ for N bolt groups, in cm^4

$I_y = \Sigma A_i y_i^2$ for N bolt groups, in cm^4

R_{si} = static reaction at bolt group i , due to weight of windlass, in kN.

8.11.5 Shear forces F_{xi}, F_{yi} applied to the bolt group i , and the resultant combined force F_i may be calculated from:

$$F_{xi} = (P_x - \alpha g M)/N \text{ in kN}$$

$$F_{yi} = (P_y - \alpha g M)/N \text{ in kN}$$

and

$$F_i = \sqrt{(F_{xi}^2 + F_{yi}^2)} \text{ kN}$$

where

α = coefficient of friction (0,5)

M = mass of windlass, in tonnes

g = gravity acceleration (9,81 m/sec^2)

N = number of bolt groups.

8.11.6 Tensile axial stresses in the individual bolts in each bolt group i are to be calculated. The horizontal forces F_{xi} and F_{yi} are normally to be reacted by shear chocks. Where 'fitted' bolts are designed to support these shear forces in one or both directions, the von Mises equivalent stresses in the individual bolts are to be calculated, and compared to the stress under proof load. Where pourable resins are incorporated in the holding down arrangements, due account is to be taken in the calculations.

8.11.7 The safety factor against bolt proof strength is to be not less than 2,0.

8.11.8 Bolts are to be of ISO 898/1 material Grade 8.8, 10.9 or 12.9 or equivalent and are to be pretensioned by controlled means to 70 to 90 per cent of their yield stress. Pretensioning is to be in accordance with the manufacturer's instructions and, in general, pretensioning by bolt torquing up to bolt size M30 may be used. Beyond this, pretensioning is to be carried out by a hydraulic tensioning device and the elongation of the bolts measured to determine pre-load. Where resin chocks are proposed plans and calculations are to be submitted for consideration.

8.11.9 The windlass is to be efficiently bedded and secured to the deck. The thickness of the deck in way of the windlass is to be increased. Adequate stiffening of the deck in way of the windlass is to be provided. The scantlings of the supporting structure and deck are to be determined by additional calculations applying the weight of the windlass combined with the resultant force on the seat due to the application of the following design loads:

- P_x (as defined in Pt 3, Ch 13, 8.11 Structural requirements for windlasses on exposed fore decks 8.11.4);
- P_y ;
- P_x and P_y combined;
- a load no less than the maximum pull developed by the windlass under normal operating conditions;
- a load no less than the ultimate breaking strength of the chain stopper, but need not be taken greater than the maximum brake holding capacity of the windlass. Requirements for chain stoppers are described in Pt 3, Ch 13, 9 Mooring of ships at single point moorings 9.

The allowable stresses given in Table 13.8.4 Allowable stress in windlass supporting structure are not to be exceeded.

Table 13.8.4 Allowable stress in windlass supporting structure

	Bending stress, in N/mm ²	Shear stress, in N/mm ²	Combined stress, in N/mm ²
Allowable stress	$\frac{150}{k}$	$\frac{87}{k}$	$\frac{213}{k}$
$k =$	material factor, see Pt 3, Ch 2, 1.2 Steel		

8.11.10 The axial tensile and compressive forces in Pt 3, Ch 13, 8.11 Structural requirements for windlasses on exposed fore decks 8.11.4 and the lateral forces in Pt 3, Ch 13, 8.11 Structural requirements for windlasses on exposed fore decks 8.11.5 are also to be considered in the design of the supporting structure.

8.12 Structural requirements associated with towing and mooring

8.12.1 The following requirements are applicable to bollards and bitts, fairleads, stand rollers and chocks used for the normal mooring and towing of the vessel, the supporting structure and their attachment to it. They are also applicable to the supporting structure of capstans, winches and similar items used for the normal mooring and towing of the vessel. Any weld, bolt or equivalent device connecting the shipboard fitting to the supporting structure is part of the shipboard fitting and is subject to the National or International standard applicable to that shipboard fitting.

8.12.2 The design criteria in this sub-Section are to be used to derive the net scantlings of the supporting structure. A corrosion addition of 2 mm is to be added to the net thickness derived.

8.12.3 Shipboard fittings for towing or mooring are to be located on longitudinals, beams and/or girders, which are part of the deck construction so as to facilitate efficient distribution of the load. Other arrangements will be specially considered provided that the strength is confirmed as adequate for the service.

8.12.4 The design load applied to shipboard fittings and supporting hull structure is not to be less than that given in Table 13.8.5 Minimum design load for deck fittings and supporting structure.

Table 13.8.5 Minimum design load for deck fittings and supporting structure

Use/Item	Minimum design load ⁽¹⁾
Normal towing (harbour/manoeuvring)	1,25 times the intended maximum towing load as indicated on the towing and mooring arrangements plan
Escort towing	minimum breaking strength of the towline given in Table 13.7.3 Equipment - Stream anchors, stream wires, towlines and mooring lines for the ship's corresponding equipment number ⁽²⁾
Mooring	1,25 times the breaking strength of the mooring line given in Table 13.7.3 Equipment - Stream anchors, stream wires, towlines and mooring lines for the ship's corresponding equipment number ⁽²⁾⁽³⁾
Winches, etc.	1,25 times the intended maximum brake holding power

Capstans	1,25 times the maximum hauling in force
<p>Note 1. If a greater design load is specified by the designer then this load is to be used.</p> <p>Note 2. The equipment number calculation is to include the maximum projected area of all deck cargo.</p> <p>Note 3. Note 7 in <i>Table 13.7.3 Equipment - Stream anchors, stream wires, toelines and mooring lines</i> is applicable.</p>	

8.12.5 The design load is to be applied according to the arrangement shown on the towing and mooring arrangement plan. The point of action of the force on the fitting is to be taken as the point of attachment of the mooring line or toeline or at a change in its direction. The total design load applied to a fitting need not be more than twice the design load, see *Figure 13.8.3 Design load applied to fittings*.

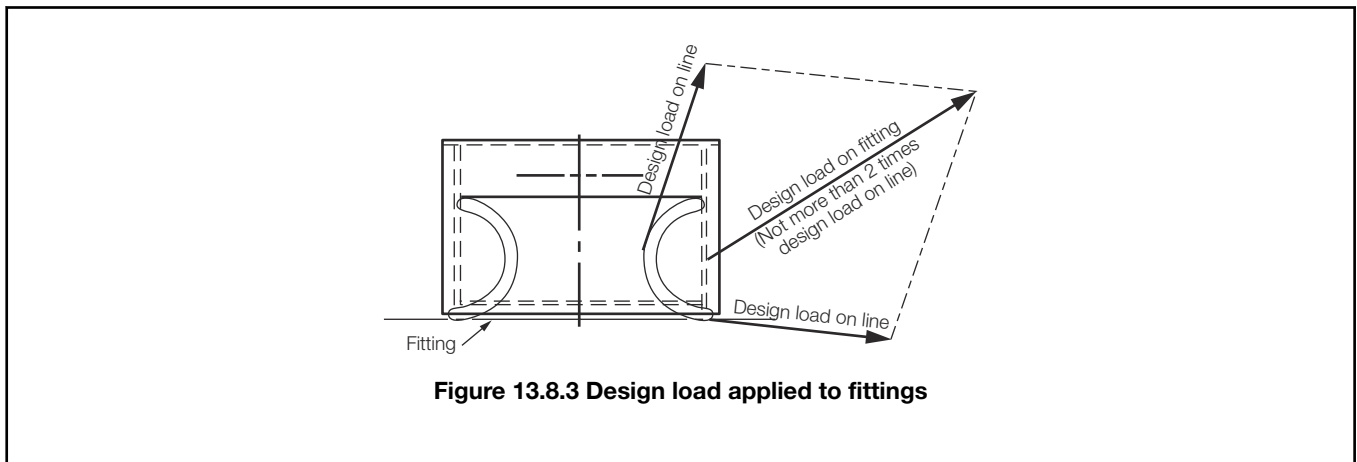

Figure 13.8.3 Design load applied to fittings

8.12.6 The selection of shipboard fittings is to be made by the shipyard in accordance with an acceptable National or International standard (e.g. ISO13795 Ships and marine technology – Ship's mooring and towing fittings – Welded steel bollards for sea-going vessels). If the shipboard fitting is not selected from an acceptable National or International Standard then the design load used to assess its strength and its attachment to the ship is to be in accordance with the design load given in *Table 13.8.5 Minimum design load for deck fittings and supporting structure* and the design is to be submitted for approval.

8.12.7 The reinforced members beneath shipboard fittings are to be effectively arranged for any variation of the direction, in both the lateral and vertical plane, of the forces acting through the arrangement.

8.12.8 The stress within the supporting structure of fittings is not to exceed that given in *Table 13.8.6 Allowable stress within the supporting structure of shipboard fittings*.

Table 13.8.6 Allowable stress within the supporting structure of shipboard fittings

	Normal stress, in N/mm ²	Shear stress, in N/mm ²
Allowable stress	$\frac{235}{k}$	$\frac{141}{k}$
<p>where</p> $k = \frac{235}{\sigma_0}$ <p>σ_0 = specified minimum yield strength of the material in N/mm²</p>		

8.12.9 The Safe Working Load (SWL) of a shipboard fitting used for normal towing and mooring is not to be greater than 80 per cent of the design load. The SWL of a shipboard fitting used for escort towing is not to be greater than the design load. For fittings used for both operations, the greater design load is to be used.

8.12.10 The SWL of each shipboard fitting is to be marked, by weld bead or equivalent, on the fitting and relates to a single post basis.

8.12.11 When determining the minimum design load for deck fitting and supporting structure the 'Mooring Equipment Number' is to be calculated as follows:

$$\text{Mooring Equipment Number} = \Delta^{2/3} + 2BH + \frac{A}{10}$$

where

A = area, in m², in profile view of the hull including the projected area of all deck cargo, within the Rule length of the vessel, and of superstructures and houses above the summer load waterline, which are within the Rule length of the vessel, and also having a breadth greater than $\frac{B}{4}$

= See also Pt 3, Ch 13, 8.12 Structural requirements associated with towing and mooring 8.12.12 and Pt 3, Ch 13, 8.12 Structural requirements associated with towing and mooring 8.12.13

B = greatest moulded breadth, in metres

H = freeboard amidships, in metres, from the summer load waterline to the upper deck, plus the sum of the heights at the centreline, in metres, of each tier of houses having a breadth greater than $\frac{B}{4}$

= See also Pt 3, Ch 13, 8.12 Structural requirements associated with towing and mooring 8.12.12, Pt 3, Ch 13, 8.12 Structural requirements associated with towing and mooring 8.12.13 and Pt 3, Ch 13, 8.12 Structural requirements associated with towing and mooring 8.12.14

Δ = moulded displacement, in tonnes, to the summer load waterline.

8.12.12 In the calculation of *H* and *A*, sheer and trim are to be ignored. Where there is a local discontinuity in the upper deck, *H* is to be measured from a notional deckline.

8.12.13 If a house having a breadth greater than $\frac{B}{4}$ is above a house with a breadth of $\frac{B}{4}$ or less, then the wide house is to be included, but the narrow house ignored.

8.12.14 Screens and bulwarks more than 1,5 m in height are to be regarded as parts of houses when determining *H* and *A*. Where a screen or bulwark is of varying height, the portion to be included is to be that length, the height of which exceeds 1,5 m.

■ Section 9 Mooring of ships at single point moorings

9.1 General

9.1.1 These requirements are applicable to ships intended to utilise the fittings standardised for single point moorings and include the type, strength and location of the required fittings.

9.1.2 A ship provided with mooring arrangements in accordance with the requirements of this Section will be eligible to be assigned the Class notation **SPM4** where a single mooring line arrangement is provided for and **DSPM4** where a dual mooring line arrangement is provided for, see Figure 13.9.1 Positioning of fairleads, chainstoppers and pedestal roller leads.

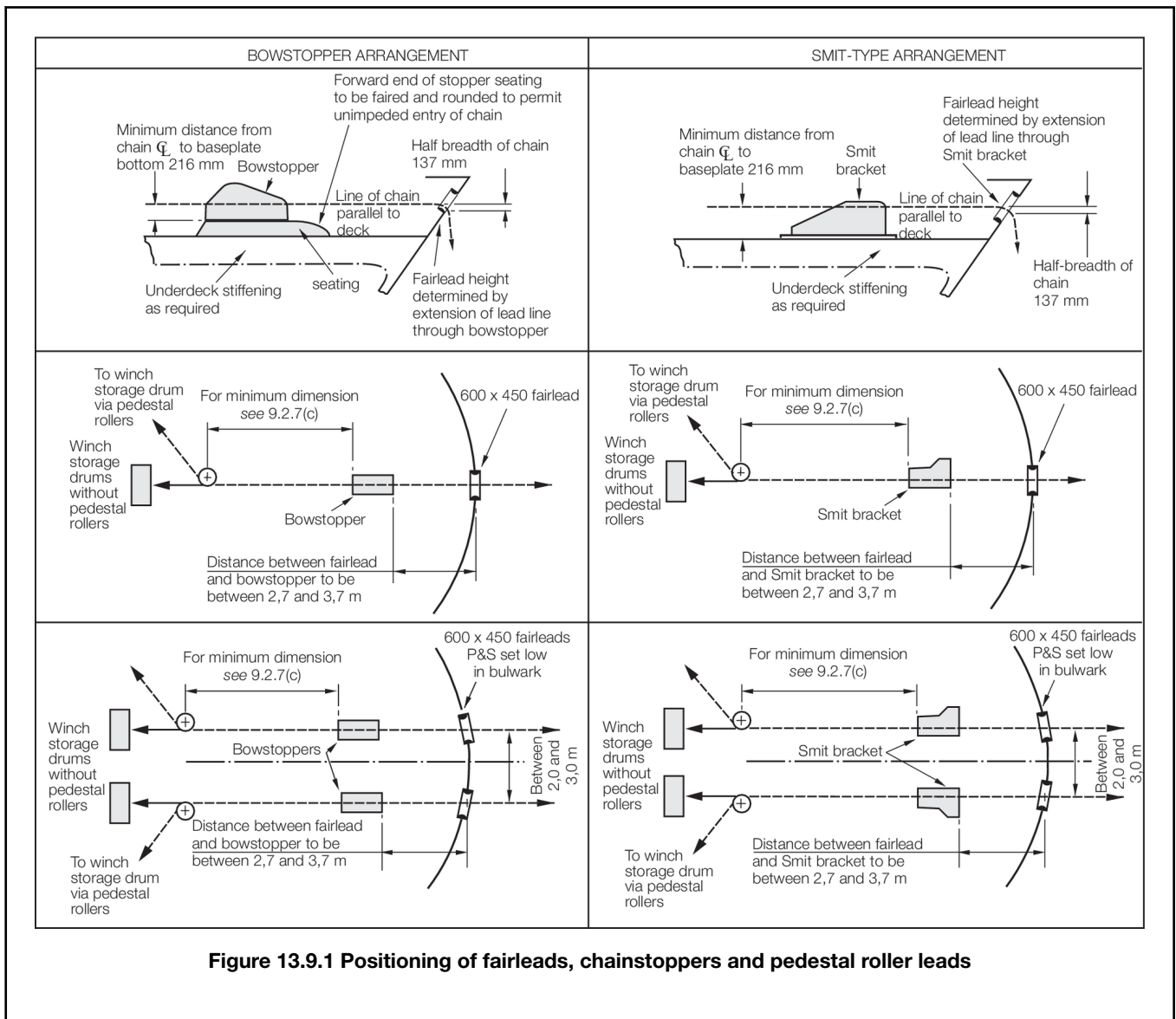

Figure 13.9.1 Positioning of fairleads, chainstoppers and pedestal roller leads

9.2 Arrangements

9.2.1 The ship is to be fitted with bow chain stoppers and/or Smit-Type Brackets, and bow fairleads. In addition, pedestal roller fairleads may be required for alignment purposes but a direct straight lead from the chain stopper to the winch storage drum is the preferred arrangement. However, consideration of safety and protection from risk of injury to mooring personnel should take priority in determining whether pedestal rollers should be fitted as well as their number and positioning.

9.2.2 In order to ensure matching with terminal mooring equipment, the requirements for shipboard fittings are specified in association with ranges of ship deadweight as shown in *Table 13.9.1 Deadweight group for shipboard fittings requirements*.

Table 13.9.1 Deadweight group for shipboard fittings requirements

Group	Deadweight in tonnes
I	≤100 000
II	>100 000 ≤150 000
III	>150 000

9.2.3 Bow chain stoppers:

- (a) The number, chain cable size and minimum safe working load of bow chain stoppers should be as given in *Table 13.9.2 Fittings requirements for deadweight group*.
- (b) Bow chain stoppers should be located between 2,7 m and 3,7 m aft of the bow fairlead and should be positioned so as to give correct alignment with the bow fairlead and the pedestal fairlead or the storage drum of the winch, see *Figure 13.9.1 Positioning of fairleads, chainstoppers and pedestal roller leads*.
- (c) The leading edge of the stopper base plate is to be suitably faired to allow unimpeded entry of the combination chafe chain into the stopper. The chain referred to, forms part of the standardised SPM equipment.
- (d) The safety factor on yield of bow chain stoppers should be a minimum of 2 when the safe working load is applied.
- (e) Details of bow chain stoppers should be submitted for approval.

Table 13.9.2 Fittings requirements for deadweight group

Group	Chain size, in mm	No. of chain stoppers	SWL, in kN (tonnes)	
I	76	1, see Note	1960	(200)
II	76	1, see Note	2450	(250)
III	76	2	3430	(350)

Note Ships in this size range may elect to fit two stoppers to ensure full range terminal acceptance, see *Pt 3, Ch 13, 9.1 General 9.1.2*.

9.2.4 Smit-Type Brackets:

- (a) Smit-Type Brackets may be fitted in lieu of bow chain stoppers for Group I and II. The fitting of Smit-Type Brackets in lieu of bow chain stoppers for Group III will be specially considered. The required number and safe working load are as given in *Table 13.9.2 Fittings requirements for deadweight group* for bow chain stoppers.
- (b) The scantlings of the pin, connecting brackets and welded attachments to the baseplate are to be determined in association with a horizontal load of 2 x SWL and a permissible shear stress of 78 N/mm² (8 kg/mm²).
- (c) Where fitted, Smit-Type Brackets should be located between 2,7 m and 3,7 m aft of the bow fairlead and should be positioned so as to give correct alignment with the bow fairlead and pedestal fairlead or the storage drum of the winch, see *Figure 13.9.1 Positioning of fairleads, chainstoppers and pedestal roller leads*.
- (d) To facilitate connection to the terminal equipment it is recommended that each Smit-Type Bracket be provided with a length of chain cable comprising a pear link, an open link, and a special shackle, see *Figure 13.9.2 Special shackle Dimensions in mm unless otherwise stated*. The safe working load should be as given in *Table 13.9.2 Fittings requirements for deadweight group* for bow stoppers.
- (e) Adjacent to each Smit-Type Bracket a lug with a recommended safe working load of 490 kN (50 tonnes) should be attached to the doubler plate. The lug should be provided with a hole of sufficient size to accept the pin of a 490 kN (50 tonnes) SWL shackle and should be used as a securing point for the chafe chain holding stopper.
- (f) Details of Smit-Type Brackets should be submitted for approval.

9.2.5 The forecastle deck in way of bow chain stoppers or Smit-Type Brackets is to have a minimum thickness of 15 mm and is to be suitably reinforced to resist horizontal loads equal to 2 x SWL as given in *Table 13.9.2 Fittings requirements for deadweight group*.

9.2.6 Bow fairleads:

- (a) One centrally located bow fairlead should be provided for ships fitted with one bow chain stopper or Smit-Type bracket. Two bow fairleads should be provided for ships fitted with two bow chain stoppers or Smit-Type brackets, see *Figure 13.9.1 Positioning of fairleads, chainstoppers and pedestal roller leads*.
- (b) Bow fairlead openings should be at least 600 x 450 mm for 76 mm chafe chain size. Where more than one bow fairlead is installed, the spacing of centres should be between 2 m and 3 m.
- (c) The height of the centre of the bow fairlead opening above the forecastle deck should be determined by the extension, parallel to the deck, of the lead line of the chain cable to the bow chain stopper or Smit-Type Bracket, see *Figure 13.9.1 Positioning of fairleads, chainstoppers and pedestal roller leads*. The fairlead should have a minimum radius equal to seven times the chain radius.

- (d) The scantlings of the fairlead are to be determined in association with a load of 2 x SWL with hawser angles up to 90 degrees from the ship's centre line, both port and starboard in the horizontal plane and to 30 degrees above and below horizontal in the vertical plane.
- (e) Details of bow fairleads and their attachment to the bulwark should be submitted for approval.

9.2.7 Pedestal roller fairleads:

- (a) Pedestal roller fairleads should have a minimum radius equal to 10 times the radius of wire mooring ropes with a fibre core, seven times the radius of wire mooring ropes with a steel core or three times the radius of synthetic mooring ropes.
- (b) The number of pedestal roller fairleads used for each bow chain stopper should not exceed two and the angle subtended by the change of direction of the pick-up rope should be minimal.
- (c) The minimum distance of pedestal roller fairleads from the bow chain stopper or Smit-Type Bracket should be 3,0 m. Any variation in the minimum distance will be specially considered.
- (d) Details of local strengthening of the forecastle deck in way of pedestal roller fairleads should be submitted for approval.

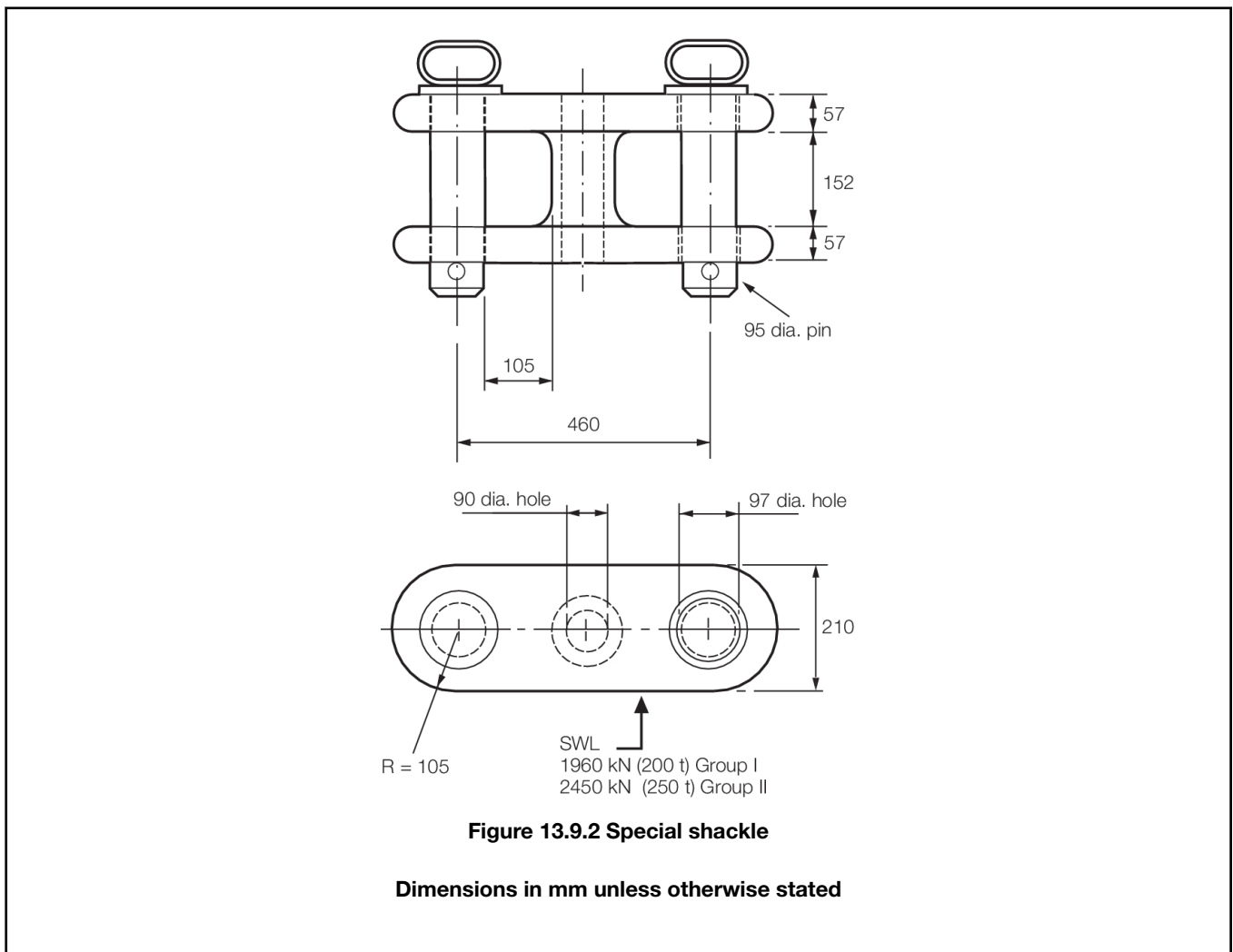

9.2.8 The winch drum used for handling the mooring gear should be capable of exerting a continuous duty pull of not less than 147 kN (15 tonnes) and be of sufficient size to accommodate 150 m of 80 mm diameter rope. Winch drum ends (warping ends) to handle pick-up ropes should be avoided. Remotely-operated winch storage drums are recommended.

■ **Section 10**
Emergency towing arrangements

10.1 Structural requirements

10.1.1 For ships equipped with emergency towing arrangements in accordance with IMO Resolution MSC.35(63) - Adoption of Guidelines for Emergency Towing Arrangements on Tankers - (adopted on 20 May 1994) Amended by Resolution MSC.132(75), the deck and its supporting structure in way of strongpoints and fairleads are to be suitably reinforced to resist design loads of at least 1,3 x specified breaking strength of the weakest component of the emergency towing arrangement, for angles of tow as specified in IMO Resolution MSC.35(63) - Adoption of Guidelines for Emergency Towing Arrangements on Tankers - (adopted on 20 May 1994) Amended by Resolution MSC.132(75). The deck in way of strongpoints and fairleads is to have a minimum thickness of 15 mm.

10.1.2 Where a ship is provided with an emergency towing arrangement and the supporting structure complies with the requirements of this Section, the ship will be eligible to be assigned the descriptive note **ETA** which will be entered in column 6 of the Register Book.

10.1.3 Stresses induced in the supporting structure and welds in way of strongpoints and fairleads, determined using the design loads from Pt 3, Ch 13, 10.1 Structural requirements 10.1.1, are not to exceed the permissible values given in Table 13.10.1 Permissible stress values. The capability of the structure to withstand buckling is also to be assessed.

Table 13.10.1 Permissible stress values

	Permissible stress N/mm ² (kgf/mm ²)
Direct stress	σ_0
Shear stress	$\frac{\sigma_0}{\sqrt{3}}$
Combined stress	σ_0
Symbols	
σ_0 = specified minimum yield stress, in N/mm ² (kgf/mm ²)	

10.1.4 The structural arrangement is to be such that continuity will be ensured. Abrupt changes of shape or section, sharp corners and other points of stress concentration are to be avoided.

10.2 Chafing chain and wire or fibre rope for Emergency Towing Arrangements

10.2.1 Chafing chains are to be manufactured, tested and certified in accordance with Ch 10, 2 Stud link chain cables for ships of the Rules for Materials Grades U2 and U3.

10.2.2 The outboard end of the chafing chain is to include a pear-shaped link allowing connection to a shackle corresponding to the type of ETA and chain grade. A typical arrangement is shown in Figure 13.10.1 Typical outboard chafing chain end.

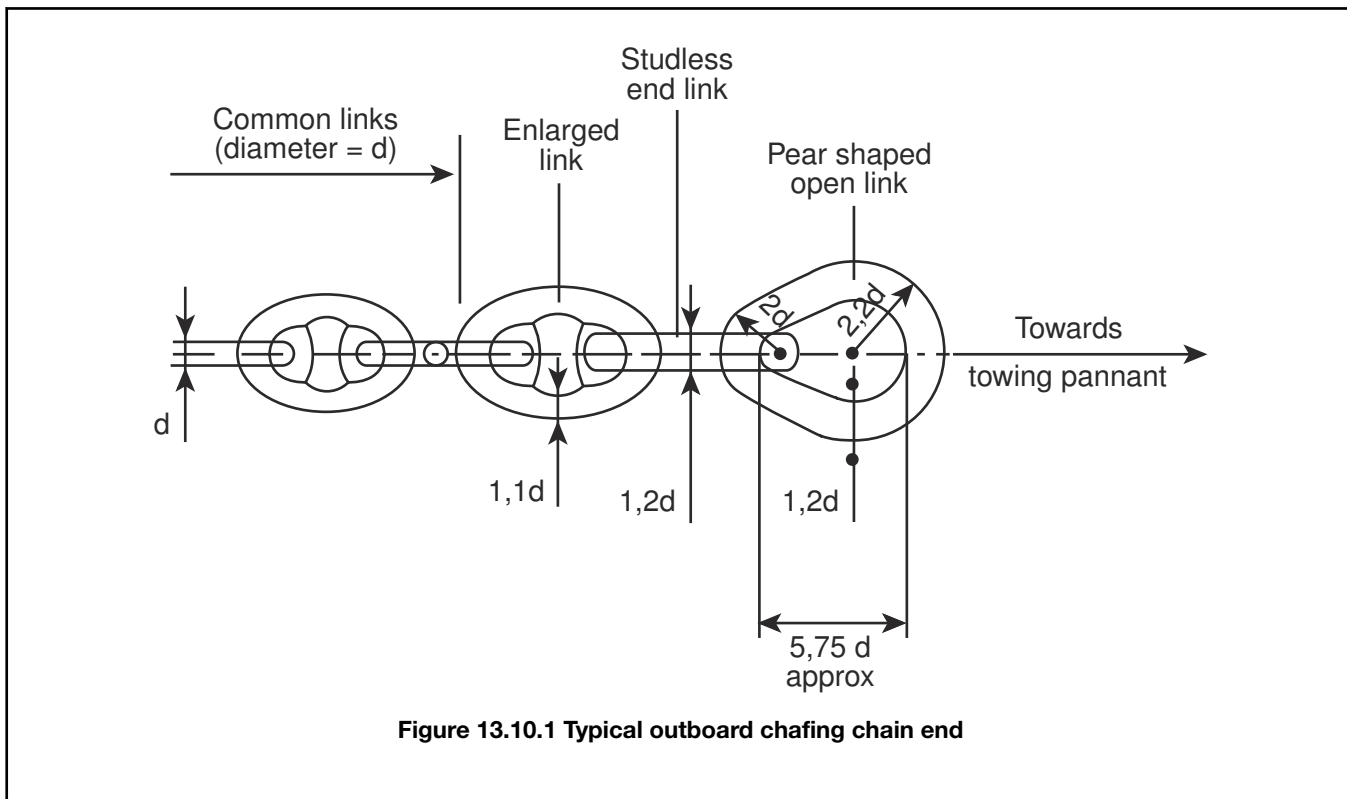

10.2.3 The chafing chain is to be able to withstand a breaking load not less than twice the safe working load (SWL). The nominal diameter of common link for chafing chains is to comply with the value indicated in *Table 13.10.2 Nominal diameter of common link for chafing chains for ETA*.

Table 13.10.2 Nominal diameter of common link for chafing chains for ETA

Type of ETA	Nominal diameter of common link, <i>d</i> min	
	Grade U2	Grade U3
ETA 1000	62 mm	52 mm
ETA 2000	90 mm	76 mm

10.2.4 Steel wire ropes are to be manufactured, tested and certified in accordance with *Ch 10, 6 Steel wire ropes* of the Rules for Materials.

10.2.5 Fibre ropes are to be manufactured, tested and certified in accordance with *Ch 10, 7 Fibre ropes* of the Rules for Materials.

Section

- 1 **General**
- 2 **Fixed cargo securing fittings, materials and testing**
- 3 **Loose container securing fittings, materials and testing**
- 4 **Ship structure**
- 5 **Container securing arrangements for stowage on exposed decks without cell guides**
- 6 **Container securing arrangements for underdeck stowage without cell guides**
- 7 **Container securing arrangements for stowage using cell guides**
- 8 **Determination of forces for container securing arrangements**
- 9 **Strength of container securing arrangements**
- 10 **Surveys**

■ *Section 1*
General

1.1 Application

1.1.1 All cargo ships, regardless of tonnage, except those engaged solely in the carriage of either liquid or solid bulk cargoes, are to be provided with a Cargo Securing Manual approved by the Flag Administration, as required by SOLAS 1974 (as amended). *Pt 3, Ch 13, 2 Rudders 2, Pt 3, Ch 13, 4 Steering gear and allied systems, Pt 3, Ch 13, 7 Equipment* (if applicable) and *Pt 3, Ch 13, 10 Emergency towing arrangements* apply to all ships for which a Cargo Securing Manual is required. It is recommended that the container securing arrangements in the Cargo Securing Manual be designed in accordance with *Pt 3, Ch 13, 3 Fixed and steering nozzles*, *Pt 3, Ch 13, 5 Bow and stern thrust unit structure, Pt 3, Ch 13, 6 Stabiliser structure, Pt 3, Ch 13, 8 Windlass design and testing* and *Pt 3, Ch 13, 9 Mooring of ships at single point moorings*. Furthermore, it is recommended that the container securing arrangements be submitted to Lloyd's Register (hereinafter referred to as LR), for formal approval. In cases where LR is authorised to carry out the approval of the Cargo Securing Manual on behalf of a National Administration and the container securing arrangements have not been designed on the basis of the LR Rules nor received formal LR approval, the Cargo Securing Manual will be annotated accordingly, highlighting this fact. In general, Cargo Securing Manuals can be approved by LR if authorised by the National Authority.

1.1.2 Fixed fittings which are part of the container lashing equipment or which may affect the strength of the ship's hull are subject to approval on the basis of the requirements of this Chapter. Details of the connection and the supporting ship structure require approval to satisfy the design loads determined in accordance with *Pt 3, Ch 14, 8 Determination of forces for container securing arrangements* or the safe working load of the fixed fitting, as applicable. Drawings are to be submitted showing details of the fittings, the attachment, the local foundations and information about the intended materials and welding.

1.1.3 The requirements for container securing arrangements have been framed in relation to ISO Standard Series 1 ISO 1496-1:1990, including Amendment Nos. 1, 2 and 3, Freight Containers. For previous ISO 1496-1:1984 containers, reference should be made to the July 2008 LR Rules. Proposals to consider higher allowable forces in accordance with ISO 1496-1, including Amendment No. 4, 2006, will be specially considered. Proposals for the securing of other types of containers will be specially considered.

1.1.4 Containers are to be loaded so as not to exceed the weights and distribution within the stack according to the Cargo Securing Manual (CSM). The permissible loading patterns are to be clearly indicated on the Container Securing Arrangement Plan carried on board the ship.

1.1.5 Containers may be approved and certified using LR's *Container Certification Scheme*.

1.1.6 Where it is intended and specified that loose or fixed parts of the container securing system are used for lifting appliance purposes, e.g. pedestal sockets and fittings used for lifting of hatch covers, or twistlocks used for vertical tandem lifting, the

requirements of LR's *Code for Lifting Appliances in a Marine Environment, November 2015* are applicable. If no approval from lifting aspects is sought, the devices will be considered as part of a container securing arrangement only.

1.1.7 For ships having the class notation **Container Ship**, an effective breakwater is to be fitted to protect the containers against green sea impact loads. As a minimum, an effective breakwater is to extend above the mid-height of the outermost containers that are to be considered as protected. For other ships which are equipped for the carriage of containers on deck, protection of the cargo is recommended by the provision of a breakwater.

1.1.8 Forward of 0,75L, it is recommended that all door ends face aft in order to improve the performance of the container walls to withstand green sea loads.

1.1.9 Improper ship handling related to course and speed or threshold phenomena like parametric rolling can create adverse forces acting on the ship and the cargo which are in excess of the forces determined on the basis of Section *Pt 3, Ch 14, 8 Determination of forces for container securing arrangements*. It is the responsibility of the Master to apply good seamanship in order to mitigate excessive ship motions to reduce forces acting on the cargo stowage arrangements.

1.2 Classification notations and descriptive notes

1.2.1 Ships with container securing arrangements which are designed and constructed in accordance with this Chapter will be eligible to be assigned the special features notation **CCSA** (certified container securing arrangements). In addition to the fixed fittings, the Initial and Periodical Survey requirements of Section *Pt 3, Ch 14, 10 Surveys* for all loose fittings are applicable. Where loose container securing fittings are supplied for part container stowage only, the special features notation will be suitably modified.

1.2.2 Ships with container securing arrangements which are designed and constructed in accordance with this Chapter, but where the Initial and Periodical Survey requirements for loose fittings in Section *Pt 3, Ch 14, 10 Surveys* are not requested, will be eligible to be assigned the descriptive note **CSA** (container securing arrangement) and for an entry to be made in column 6 of the *Register Book*.

1.2.3 The advantage of having an onboard lashing program to calculate forces acting on the stowage arrangement is highlighted. It is recommended that all ships carrying containers on a regular basis be equipped with such a tool. This may be an extension to the loading instrument covered under *Pt 3, Ch 4, 8.3 Loading instrument*. It is recommended that the program be approved by LR. If the program to carry out lashing calculations is approved by LR and installed and maintained in accordance with the requirements of this Chapter, the ship will be eligible to be assigned the special features notation **BoxMax**.

1.2.4 It is a prerequisite for assignment of the special features notation **BoxMax** that the container securing arrangements in the Cargo Securing Manual are designed in accordance with this Chapter and submitted to Lloyd's Register for formal approval.

1.2.5 The container securing arrangements of a container ship may take into account specific voyage routes and seasons, provided the ship is eligible for the special features notation **BoxMax**, see *Pt 3, Ch 14, 1.2 Classification notations and descriptive notes 1.2.3*, the onboard lashing program is capable of performing calculations specific to defined sea areas and seasons and the weather-dependent factors for these areas and seasons have been supplied by LR. In this case, if the weather-dependent factors have been supplied by LR for specific sea areas, the ship will be eligible to be assigned the special features notation **BoxMax(V)**. If the factors have been supplied by LR for specific sea areas and seasons, the ship will be eligible to be assigned the special features notation **BoxMax(V,W)**. See *Pt 3, Ch 4, 8.3 Loading instrument*.

1.2.6 A ship designed to carry containers that is provided with safe access and securing arrangements in accordance with the Provisional Rules and Regulations for Ergonomic Container Lashing will be eligible to be assigned the special features notation **ECL** (Ergonomic Container Lashing), with supplementary descriptor.

1.3 Plans and information required

1.3.1 For all fixed cargo securing arrangements, except container securing arrangements, the following information and plans are to be submitted:

- (a) Details of certification including safe working load (SWL) of fixed cargo securing fittings.
- (b) Plans of structure in way of fixed cargo securing fittings.
- (c) Direction of loads imposed on the ship's fixed cargo securing fittings.
- (d) A general arrangement of fixed cargo securing fittings.

1.3.2 For container securing arrangements, the following plans and information are to be submitted:

- (a) General arrangement plan showing the disposition and design weights of the containers.
- (b) Details of materials, design, scantlings of cell guides structure, lashing bridges, pedestals, and other container securing arrangements, where fitted.

- (c) Details of certification, including safe working load (SWL), of fixed and loose container securing fittings.
- (d) Plans of structure in way of fixed container securing fittings and arrangements.
- (e) Design values of the following ship parameters for the container load departure and arrival conditions:
 - (i) Moulded draught (T_d)
 - (ii) Transverse metacentric height (GM).
- (f) Design wind speed (V_w).
- (g) The lashing calculations in the Cargo Securing Manual are to be based on two design GM values. The lower design value is to be taken as 2,5 per cent of the breadth B , and the upper design value is to be taken as 7,5 per cent of B . In addition to these two design GM values, actual GM values of the ship in the container loaded condition from the approved trim and stability booklet are to be included when the actual design GM values are outside the above range.

1.3.3 Where containers of types other than ISO containers are to be incorporated in the stowage arrangement, the Cargo Securing Manual is to indicate clearly the locations where these containers are stowed. The manual is also to indicate the container weights and required securing arrangements for stacks composed entirely of ISO Standard containers.

1.4 Securing systems

1.4.1 Containers are to be secured by one, or a combination, of the following systems:

- Corner locking devices.
- Rod, wire or chain lashings.
- Buttresses, shores or equivalent structural restraint.
- Cell guides.

Alternative systems will be considered on the basis of their suitability for the intended purpose.

1.4.2 Dunnage is not to be used in association with approved container securing systems except where forming part of an approved line load stowage, see Pt 3, Ch 14, 5.5 Line Load stowage.

1.5 Symbols and definitions

1.5.1 The following definitions are applicable to this Chapter, except where otherwise stated:

a = breadth of the container, in metres (for longitudinally stowed containers)

b = length of the container, in metres (for longitudinally stowed containers)

c_i = height of container i , in metres

d_i = flange thickness of container securing device (e.g. twistlock) below container i , in metres

a_0 = acceleration parameter

$$= f_{HS} \left(1,58 - 0,47C_b \right) \left(\frac{2,4}{\sqrt{L}} + \frac{34}{L} - \frac{600}{L^2} \right)$$

a_{surge} = longitudinal acceleration due to surge, in m/s^2

$$= 0,275a_0 g$$

a_{sway} = transverse acceleration due to sway, in m/s^2

$$= 0,55a_0 g$$

a_{heave} = vertical acceleration due to heave, in m/s^2

$$= a_0 g$$

a_{roll} = roll acceleration at the centre of motion of the vessel, in rad/s^2

$$= 0,69 \frac{\varphi}{T_r^2}$$

a_{pitch} = acceleration due to pitch, in rad/s²

$$0,69 \left(1 + \frac{0,98}{\sqrt{L}} \right) \frac{\psi}{T_p^2}$$

T_p = period of pitch of the ship, in seconds, to be taken as specified in *Table 14.8.1 Ship motions*

T_r = period of roll of the ship, in seconds, to be taken as specified in *Table 14.8.1 Ship motions*

φ = maximum single amplitude of roll, in degrees, to be taken as specified in *Table 14.8.1 Ship motions*

Ψ = maximum single amplitude of pitch, in degrees, to be taken as specified in *Table 14.8.1 Ship motions*

e = base of natural logarithms

$$= 2,7183$$

f_{ap} = hull form coefficient

= for Motion Case MC1:

$$= 1,2 R_A^{0,3} \text{ for } R_A > 1,0$$

$$= 1,2 \text{ for } R_A \leq 1,0$$

= for all other Motion Cases:

$$= 1,0$$

R_A = area ratio factor for combined stern and bow shape, defined in *Pt 4, Ch 2, 2.4 Design vertical wave bending moments*. For the purpose of container stowage calculation, R_A is to be taken as 1,5 if this value is not available

f_{BK} = bilge keel coefficient

$$= 1,2 \text{ for ships without bilge keels}$$

$$= 1,0 \text{ for ships with bilge keels}$$

f_{Hs} = weather-dependent factor for acceleration

$$= 1,0 \text{ for unrestricted worldwide service}$$

f_{HsP} = weather-dependent factor for pitch

$$= 1,0 \text{ for unrestricted worldwide service}$$

f_{HsR} = weather-dependent factor for roll

$$= 1,0 \text{ for unrestricted worldwide service}$$

f_{HsW} = weather-dependent factor for whipping acceleration

$$= 1,0 \text{ for unrestricted worldwide service}$$

C_{p1} = hull whipping factor

$$= 1 + f_{MC} f_{wh} f_{HsW}$$

f_{MC} = Motion Case coefficient

= 1,0 f_{wl} for MC1

= 0 for MC2

= 0,5 f_{wl} for MC3

= 0,25 f_{wl} for MC4

= 0,5 f_{wl} for MC5

= 0 for MC6

f_{wh} = whipping coefficient

= 0,55 for $x_c/L \leq 0,25$

= 0,20 at $x_c/L = 0,5$

= 0,45 for $x_c/L \geq 0,75$

intermediate values are to be obtained by linear interpolation

f_{wl} = length-dependent factor for whipping

= 0 for $L \leq 250$ m

= 1,0 for $L \geq 350$ m

intermediate values are to be obtained by linear interpolation

g = acceleration due to gravity and is to be taken as 9,81 m/s²

x_c = longitudinal centre of gravity of a container forward of the AP, in metres

z_c = vertical centre of gravity of a container above the keel, in metres

x_i = longitudinal coordinate of the centre of container i , in metres, from O_m measured positive forwards in ship coordinate system, see *Figure 14.1.1 Diagrammatic representation of symbols*

= $X_c - X_{om}$

y_i = transverse coordinate of the centre of container i , in metres, from O_m measured positive to port in ship coordinate system, see *Figure 14.1.1 Diagrammatic representation of symbols*

z_i = vertical coordinate of the centre of container i , in metres, from O_m measured positive upwards in ship coordinate system, see *Figure 14.1.1 Diagrammatic representation of symbols*

= $Z_c - Z_{om}$

x_{om} = longitudinal centre of motion forward of the AP. To be taken at the LCF of the ship

z_{om} = vertical centre of motion above the keel. To be taken as the greater of $2T_c/3 + KG/3$, T_c or $D/2$

A = side area of the container, in m²

GM = transverse metacentric height of the ship, in metres

KG = vertical distance of the centre of gravity of the ship above the keel, in metres

L = Rule length, in metres, see Pt 3, Ch 1, 6.1 Principal particulars 6.1.1

C_b = block coefficient, see Pt 3, Ch 1, 6.1 Principal particulars 6.1.6

MC_n = Motion Case n

LCF = longitudinal centre of flotation. To be taken as $0,48L$

O_m = centre of motion, to be taken on the centreline at x_{om} and z_{om} , see Figure 14.1.1 Diagrammatic representation of symbols and Figure 14.1.2 Ship coordinate system and sign convention of motions

R = the rating, or maximum operating gross weight for which the container is certified, and is equal to the tare weight plus payload of the container, in tonnes

T_c = moulded draught in the container load condition, in metres

V_w = wind speed, in m/s. For ships with an unrestricted worldwide service area notation, a wind speed of 40 m/s is to be applied

W = weight of the container and contents, in tonnes. The following minimum weights W are to be used:

- = 2,5 tonnes for 20 ft containers
- = 3,5 tonnes for 40 ft containers
- = 4,0 tonnes for 45 ft containers
- = 4,5 tonnes for 48 ft and 53 ft containers.

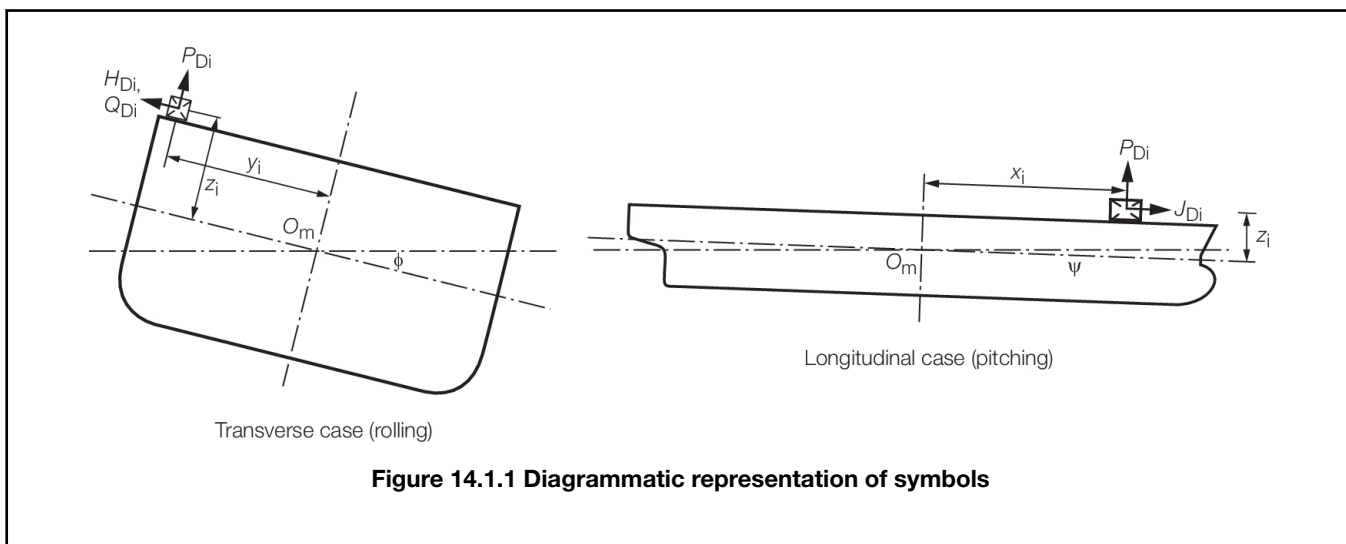

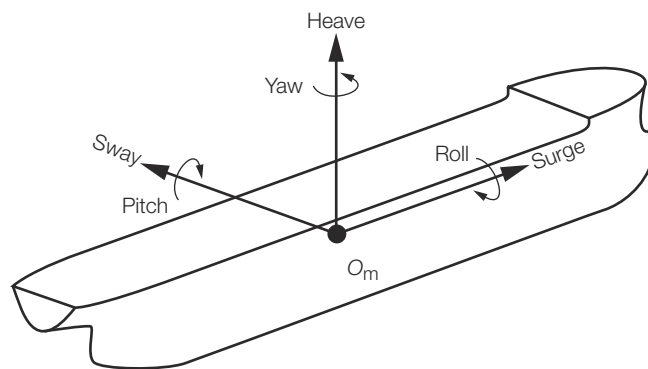

Figure 14.1.2 Ship coordinate system and sign convention of motions

1.5.2 The sign convention for ship motions and accelerations is shown in *Figure 14.1.2 Ship coordinate system and sign convention of motions*. This is based on a right-handed coordinate system. The roll, pitch and yaw motions are defined positive clockwise as shown. For instance, positive sway is defined as the translation toward port and positive pitch as the rotation of the bow down and stern up.

■ Section 2

Fixed cargo securing fittings, materials and testing

2.1 General

2.1.1 Randomly selected samples of fixed cargo securing fittings are to be subjected to prototype testing and, upon satisfactory completion, will be granted General Approval.

2.1.2 Randomly selected samples drawn from production runs are to be subjected to production testing prior to delivery to the ship.

2.1.3 Cargo securing fittings, certified by an organisation other than LR, will be accepted where the certification scheme is to the satisfaction of LR.

2.2 Materials and design

2.2.1 Steel used for the construction of the fixed cargo securing fittings is to comply with the requirements of the *Rules for the Manufacture, Testing and Certification of Materials* (hereinafter referred to as the Rules for Materials) or with an equivalent specification acceptable to LR. Due account is to be taken of the grade and tensile strength of the hull material in way of the attachment. The chemical composition of the steel is to be such as to ensure acceptable qualities of weldability. Where necessary, tests are to be carried out to establish specific welding procedures.

2.2.2 Where securing arrangements are intended to operate at low ambient temperatures, special consideration is to be given to the specification of the steel.

2.2.3 Proposals for the use of materials other than steel will be specially considered.

2.2.4 Attention is drawn to the need for measures to be taken to prevent water accumulation in pockets or recesses that could lead to excessive corrosion.

2.3 Prototype testing

2.3.1 Prototype tests to determine the breaking or failure loads are to be carried out on at least two randomly selected samples of each item used in the securing system. The relationship between design breaking load and safe working load (SWL) is to be as indicated in *Table 14.2.1 Design breaking loads and proof loads for fixed cargo securing fittings*.

Table 14.2.1 Design breaking loads and proof loads for fixed cargo securing fittings

Minimum design breaking load		Minimum proof load	
for SWL ≤ 400 kN	for SWL > 400 kN	for SWL ≤ 400 kN	for SWL > 400 kN
2 x SWL	SWL + 400 kN	1,5 x SWL	SWL + 200 kN

Note Breaking and proof loads for fixed cargo securing fittings of a material other than steel will be specially considered.





2.3.2 The Surveyor is to be satisfied that the design and materials of the fittings are in accordance with the approved plans.

2.3.3 For acceptance, no permanent deformation (other than due to initial embedding of component parts) is to be induced by test loads up to the proof load given in *Table 14.2.1 Design breaking loads and proof loads for fixed cargo securing fittings*.

2.3.4 When considering the test modes, all expected directions of operation are to be taken into account. Jigs are to be employed, where necessary, in order that satisfactory simulation is obtained.

2.3.5 In the interest of standardisation of the strength of container securing fittings, safe working loads in accordance with *Table 14.2.2 Test loads and test modes for fixed container securing fittings* are recommended.

Table 14.2.2 Test loads and test modes for fixed container securing fittings

Item No.	Description	Required test modes	Recommended minimum, in kN			
			SWL	Proof load	Breaking load	
1	Flush socket		Pull-out load	250	375	500
2	Pedestal socket		Pull-out load	250	375	500
			Tangential load	200	300	400
3	'D' ring		Tensile load	250	375	500
4	Lashing plate		Tensile load	250	375	500

Note 1. For items 3 and 4, where specifically designed for use with chain or steel wire rope (SWR) lashings, a lesser SWL may be considered.

Note 2. For items 1 and 2, where multiple flush sockets or pedestal sockets are involved, test loads are to be applied simultaneously to each socket opening which can be loaded simultaneously in service.

Note 3. For item 4, where multiple lashing points are fitted in one deck plate fitting, testing is to be similarly arranged as for Note 2.

Note 4. Where containers with strength higher than required for ISO containers are used, consideration will be given to the required minimum loads.

Note 5. The test modes illustrated above are diagrammatic only.

2.3.6 Where one of the required two randomly selected test samples fails before the design breaking load is reached, this can be accepted, provided that:

- (a) the failure is not less than 95 per cent of the design breaking load;
- (b) an additional randomly selected sample is tested satisfactorily; and
- (c) the average failure load of the three randomly selected samples is equal to or greater than the design breaking load.

2.4 Production testing

2.4.1 The nature and extent of proposed production testing will be considered by LR, but the arrangements are to be at least equivalent to one of the following testing procedures:

- (a) One randomly selected sample from every 50 pieces, or from each batch if fewer than 50 pieces, is to be proof loaded in accordance with *Table 14.2.1 Design breaking loads and proof loads for fixed cargo securing fittings*.
- (b) All fittings are to be loaded to the SWL of the item.

2.4.2 Consideration will be given to a reduced frequency of the mechanical production testing proposed in *Pt 3, Ch 14, 2.4 Production testing 2.4.1*, provided that:

- (a) the prototype test results indicate a breaking load at least 50 per cent greater than that required by *Table 14.2.1 Design breaking loads and proof loads for fixed cargo securing fittings*; and
- (b) a suitable non-destructive inspection procedure is agreed.

2.4.3 Permanent deformation (other than that due to initial embedding of component parts) will not be accepted unless tests are conducted in accordance with *Pt 3, Ch 14, 2.4 Production testing 2.4.1* and the SWL of the sample is 250 kN or greater. In this case, consideration may be given to acceptance of permanent deformation in the load range between SWL + 125 kN and the proof load, provided that satisfactory manual operation can be achieved after completion of tests.

2.4.4 In the event of premature failure or serious plastic deformation occurring in a test sample, a further randomly selected sample is to be selected for testing. In the event that this sample is found to be unsatisfactory, the associated batch will be rejected.

■ *Section 3*

Loose container securing fittings, materials and testing**3.1 General**

3.1.1 Randomly selected samples of loose container securing fittings are to be subjected to prototype testing and, upon satisfactory completion, will be granted General Approval.

3.1.2 Randomly selected samples drawn from production runs are to be subjected to production testing prior to delivery to the ship in accordance with *Pt 3, Ch 14, 3.4 Production testing*.

3.1.3 Loose container securing fittings, certified by an organisation other than LR, will be accepted where the certification scheme is to the satisfaction of LR.

3.1.4 In the following, the term 'fully automatic fitting' is used to describe fittings which do not require manual operation during unloading of the containers. It should be noted that usually these fittings do not mechanically secure the container in the vertical direction (perpendicular to the hatch cover) in the upright condition when subjected to pure vertical motions. Other modes of operation and novel design will be specially considered.

3.2 Materials and design

3.2.1 Steel used for loose container securing fittings is to comply with the requirements of the Rules for Materials or with an equivalent specification acceptable to LR.

3.2.2 Where loose container securing fittings are intended to operate at low ambient temperatures, special consideration is to be given to the specification of the steel.

3.2.3 Proposals for the use of materials other than steel will be specially considered.

3.2.4 Locking devices and other fittings which are inserted into the container castings on the quayside before lifting on board are to be such as to minimise the risk of them working loose under the effects of vibration and the risk of them falling out.

3.2.5 For twistlocks, bottom twistlocks, midlocks, stackers with intermediate plates and fully automatic fittings, the contact areas, for both tension and compression between the fitting and the corner castings of the containers, are to be such as not to exceed a bearing stress of 300 N/mm² under the safe working load of the fitting. No increase in the permissible stress level will be given due to higher strength material of the fittings. In the case where the design is such that the contact area is sloped or inclined and not parallel to the container corner casting, the effective contact area will be specially considered.

3.3 Prototype testing

3.3.1 Prototype tests are to be in accordance with Pt 3, Ch 14, 2.3 Prototype testing 2.3.1, except that Table 14.3.1 Design breaking loads and proof loads for loose container securing fittings and Table 14.3.2 Test loads and test modes for loose container securing fittings are to be applied in lieu of Table 14.2.1 Design breaking loads and proof loads for fixed cargo securing fittings and Table 14.2.2 Test loads and test modes for fixed container securing fittings respectively. For vertical lashing, see Pt 3, Ch 14, 5.4 Containers in more than two tiers 5.4.7.





Table 14.3.1 Design breaking loads and proof loads for loose container securing fittings



Item	Min. proof load		Min. design breaking load	
	SWL ≤ 400 kN	SWL > 400 kN	SWL ≤ 400 kN	SWL > 400 kN
Lashings				
Wire rope			3 x SWL	
Rod: higher tensile steel	1,5 x SWL	SWL + 200 kN	2 x SWL	SWL + 400 kN
Chain mild steel			3 x SWL	
: higher tensile steel			2,5 x SWL	
Other loose container securing fittings	1,5 x SWL		2 x SWL	

Note 1. Higher tensile steel is defined for this purpose as steel having a yield stress not less than 315 N/mm².

Note 2. Breaking and proof loads for lashings of material other than steel will be considered.

Table 14.3.2 Test loads and test modes for loose container securing fittings

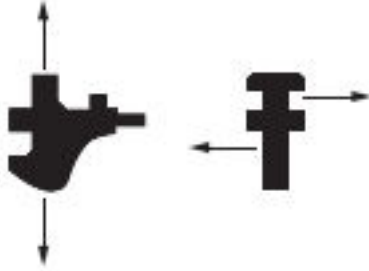
Item No.	Description	Required test modes	Recommended minimum, in kN		
			SWL	Proof load	Breaking load
1	Lashing rod		180	270	360
2	Lashing rod (HTS)		250	375	500
3	Lashing chain (MS)		80	—	200
4	Lashing chain (HTS)		100	—	300
5	Lashing steel wire rope		120	—	360
6	Turnbuckle	 Tensile load	250	375	500
7	Twistlock (manual, semi-automatic and fully automatic fittings)	 Shear load	200	300	400
		 Tensile load	250	375	500

8	Midlock		Shear load	200	300	400
			Tensile load	250	375	500
9	Stacker		Shear load	200	300	400

Note 1. Where containers with strength higher than required for ISO containers are used, special consideration will be given to the required minimum loads.

Note 2. The test modes illustrated above are diagrammatic only.

Note 3. Other fittings not covered in this Table may be specially considered, see also Pt 3, Ch 14, 3.5 Function and environmental testing 3.5.1.

Note 4. For assessment of a para-lash arrangement, see Pt 3, Ch 14, 5.4 Containers in more than two tiers 5.4.4, where each lashing rod is modelled, the SWL is to be taken as 0,75 times the SWL of a single lashing. Where a single lashing rod is used to model both rods, the SWL is to be taken as 1,5 times the SWL of a single lashing. See also Pt 3, Ch 14, 9.5 Forces in the lashing devices 9.5.2.

3.4 Production testing

3.4.1 The nature and extent of proposed production testing will be considered by LR, but the arrangements are to be at least equivalent to one of the following testing procedures:

(a) For:

- (i) **Loose container securing fittings except chain or wire rope lashings.** One randomly selected sample from every 50 pieces, or from each batch if fewer than 50 pieces, is to be proof loaded in accordance with Table 14.3.1 Design breaking loads and proof loads for loose container securing fittings.
- (ii) **Chain or wire rope lashings.** One randomly selected sample from every 50 pieces, or from each batch if fewer than 50 pieces, is to be tested to breaking.

(b) All fittings, securing devices and lashings are to be proof loaded to the SWL of the item and in addition, one randomly selected sample from every batch of chain or wire rope lashings is to be tested to breaking.

3.4.2 Permanent deformation (other than that due to initial embedding of component parts) will not be accepted unless tests are conducted in accordance with Pt 3, Ch 14, 3.4 Production testing 3.4.1 and the SWL of the sample is 250 kN or greater. In this case, consideration may be given to acceptance of permanent deformation in the load range between SWL + 125 kN and the proof load, provided that satisfactory manual operation can be achieved after completion of tests.

3.4.3 In the event of premature failure or serious plastic deformation occurring in a test sample, a further randomly selected sample is to be selected for testing. In the event that this sample is found to be unsatisfactory, the associated batch will be rejected.

3.5 Function and environmental testing

3.5.1 For fittings of novel design or with special features, in addition to the prototype and production testing, a function test may be required to demonstrate that the fitting is fit for purpose. Details of the function test will be considered on an individual basis, taking into consideration the mode of operation of the fitting. In addition, LR reserves the right to require environmental tests. The actual test depends on the individual design of the fitting. The tests are to verify that environmental and ageing effects, such as corrosion, icing, debris contamination, etc. do not impinge on the safe operation of the fitting. In this case, LR reserves the right to require the submission of maintenance instructions as part of the approval procedure.

■ **Section 4**
Ship structure

4.1 General

4.1.1 The ship structure and hatch covers in way of fixed cargo securing fittings are to be strengthened as necessary, see Pt 3, Ch 14, 1.1 Application 1.1.2.

4.1.2 A breakwater may be required, see Pt 3, Ch 14, 1.1 Application 1.1.7.

4.2 Strength

4.2.1 The SWL of the fixed cargo securing fitting is to be used as the design load when approving the weld attachments and the support structure of the fixed cargo securing fitting.

4.2.2 For container securing arrangements, the design load when approving the weld attachment and supporting structure is to be calculated in accordance with Pt 3, Ch 14, 9 Strength of container securing arrangements.

4.2.3 When considering the loads, all expected directions of operation are to be taken into account.

4.2.4 Stresses induced in the weld attachments, supporting structure, cell guides, lashing bridges and other structures serving as fixed cargo securing points, determined using the design loads as defined in Pt 3, Ch 14, 4.2 Strength 4.2.1, are not to exceed the permissible values given in Table 14.4.1 Permissible stress values.

Table 14.4.1 Permissible stress values

	Permissible stress, N/mm ²
Normal stress (bending, tension, compression)	0,67σ _o
Shear stress	0,4σ _o
Combined stress	0,86 σ _o
Symbols	
σ _o = specified minimum yield stress, in N/mm ²	

■ **Section 5**
Container securing arrangements for stowage on exposed decks without cell guides

5.1 General

5.1.1 Containers stowed on deck or on hatch covers are generally to be aligned in the fore and aft direction (longitudinally stowed), but alternative arrangements will be considered.

5.1.2 Containers are to be stowed so that they do not extend beyond the ship's side. Adequate support is to be provided where they overhang hatch coamings or other deck structures. The stowage arrangements are to be such as to permit safe access for personnel in the necessary working of the ship, and to provide sufficient access for operation and inspection of the securing devices.

5.1.3 Where containers are stowed on hatch covers, the covers are to be effectively restrained against sliding by approved type stoppers or equivalent. Details of the locations of stoppers relative to the supporting structure are to be submitted at an early stage.

5.1.4 Stanchions and similar structure supporting containers and securing devices, such as D-rings for lashings, are to be of adequate strength for the imposed loads and of sufficient stiffness to minimise any deflection which could lead to a reduction in the effectiveness of the securing device.

5.1.5 In the region forward of 0,75L, additional securing devices may be required due to green sea forces, see Pt 3, Ch 14, 8.2 Ship motion, wind and green sea forces acting on containers 8.2.8.

5.1.6 In general, stowage of heavy containers on top of lighter containers is to be avoided, unless validated as being satisfactory by an approved onboard lashing program or covered by the approved container securing arrangement.

5.1.7 Regarding the use of fully automatic fittings, the following requirements apply:

- (a) For fittings where the locking method requires defined clearances between the corner castings and the fixed foundations, such fittings are not to be used at the lowest tier of a stack which is resting with one side on a hatch cover panel and bridging to a container stanchion. The same applies if the stack is resting on different hatch cover panels or foundations where relative deflection during ship operation can occur.
- (b) If the lashing system consists of a combination of fully automatic fittings with lashing rods, only internal cross lashings are to be used. No external lashings or vertical lashings are to be applied, unless the clearance of the loose securing fitting under safe working loads is insignificantly small. Alternative arrangements will be specially considered, taking into consideration the clearances of the fittings.

5.2 Containers in one tier

5.2.1 Containers are to be secured at their lower corners by approved locking devices.

5.2.2 Alternatively, containers may be secured by lashings fitted diagonally or vertically at both ends of each container, in association with cone fittings at each container corner.

5.3 Containers in two tiers

5.3.1 Containers are to be secured at their lower corners at each tier by approved locking devices.

5.3.2 Where the calculations indicate that separation forces will not occur at any point in the stack, double stacking cones may be fitted at all internal corners of the stack and bridge fittings used to connect the tops of the rows in the transverse direction. Locking devices are to be fitted at all external corners.

5.3.3 Alternatively, containers may be secured by lashings in association with stacking cones or, where the calculations indicate that separation forces may occur, with locking devices.

5.4 Containers in more than two tiers

5.4.1 Containers are to be secured at their lower corners at each tier by approved locking devices.

5.4.2 Alternatively, containers may be secured by lashings. One or two tiers of lashings may be fitted in association with stacking cones or, where the calculations indicate that separation forces may occur, with locking devices.

5.4.3 When lashings are employed, they are usually fitted to the bottom corner casting of a container. Proposals to attach lashings to the top casting of a container will be considered. The reduced strength of the upper corner casting compared to the lower corner castings is to be taken into account.

5.4.4 Proposals to use lashings in pairs (para-lash arrangements) will be considered. Lashings in pairs are generally to be attached one to the bottom corner fitting of the upper tier and the other to the top corner fitting of the lower tier container. Suitable connections are to be provided at the lower ends. The effectiveness of paired lashings is to be taken as equal to 1,5 times that of a single lashing.

5.4.5 Where tiers are fitted at higher levels, they are to be secured by locking devices at each corner and each tier.

5.4.6 Proposals to use horizontal lashings connected to lashing bridges will be specially considered. The forces in such securing systems are to be determined by direct calculations, taking into account the following effects:

- stiffness of the container walls, the lashings and the lashing bridge; and
- the possible horizontal displacements of the containers relative to the lashing bridge due to the clearances of the hatch cover stoppers and the container securing fittings.

5.4.7 When vertical lashings are used in combination with container securing fittings, consideration is to be given to the vertical clearances between the fittings and the container corner castings:

- (a) The lashing assembly is to remain elastic when subject to an elongation equating to the number of interface fittings fitted below the point where the vertical lashing is applied to the stack. In order to avoid overstressing of the rod and the turnbuckle, provision of spring or elastic elements incorporated into the turnbuckle may be advantageous. When lashing from lashing bridge level, the number of interfaces is to be counted down to the level where the lowest container is resting. The lashing rod is to be fitted to the bottom casting of the container. For container securing fittings having design clearances in accordance with ISO 3874, a nominal clearance per fitting of 10 mm is to be taken to determine the total elongation of the lashing system. For fittings having clearances in excess of 10 mm, the total elongation is to be calculated, taking into consideration the higher clearances.
- (b) A prototype test is to be carried out to demonstrate that the vertical lashing has a safe working load of 150 kN when elongated up to the calculated total design clearance plus 10 per cent without plastic deformation.
- (c) It is recommended that the load-bearing effect of vertical lashing arrangements be explicitly taken into account when performing lashing calculations. Where this is not done, it is acceptable to allow the permissible calculated lifting force to be increased by 150 kN in addition to the safe working load of the container securing fitting. The nominal lifting force is not to exceed 400 kN at the securing fittings below the fitting position of the vertical lashing.

5.4.8 For stowage arrangements incorporating fully automatic fittings which do not mechanically secure the container in pure vertical direction when subject to vertical motions, it is to be ensured that no separation occurs under the load cases specified in *Pt 3, Ch 14, 8 Determination of forces for container securing arrangements*. In addition, where exposed stacks are secured with fully automatic fittings without internal cross lashings, provision is to be made to prevent buoyancy forces acting on the container which could disengage the containers. In this case, the use of effective side screens is required. Otherwise, the first tier of containers is to be secured by manual or semi-automatic twistlocks.

5.4.9 If the carriage of one or more tiers of 20 ft containers being overstowed with at least one tier of 40 ft containers, the so-called 'Russian Stow Arrangement', is desired, the following requirements apply.

- (a) At the 20 ft gap the containers are to be secured by means of midlocks, whereas the fore and aft ends are to be secured by twistlocks and if necessary supplemented by lashing rods.
- (b) The 40 ft overstow container is to be secured by twistlocks or if necessary with a combination of twistlocks and lashing rods. The stack is to be assessed in a twostep procedure, as follows:
 - (i) For location at the 40 ft ends, the entire mixed stack is to be considered as a 40 ft stack. The weights of the 40 ft containers are to be considered in the calculations. For the tiers of 20 ft containers, the weight of one 20 ft container is to be taken as the basis for the calculation at each tier.
 - (ii) For the location of the 20 ft tiers at the mid-bay position, the assessment is to be carried out as for an unlashd stack. The 40 ft overstow container does not need to be taken into consideration.

5.5 Line Load stowage

5.5.1 Where the containers are supported on bearers placed to distribute the stackweight as Line Loads, the following requirements are to be complied with:

- (a) The stack is, in general, to comprise a maximum of two tiers of loaded containers.
- (b) The load from the upper tier is to be transferred through the container corners. Line loading is not to be used between tiers.
- (c) The load on each vertical corner post of the bottom tier, calculated in accordance with *Pt 3, Ch 14, 9 Strength of container securing arrangements*, is not to exceed one half of the Rated Load of the container.
- (d) Where the calculations indicate that lifting forces may occur, locking devices are to be fitted at the container corners.
- (e) The clearance below the bottom container corner casting is to be such that the stacking cone or equivalent cannot be dislodged under shear loading.

5.5.2 Where an approved Line Load stowage system is installed, the special features notation will be suitably modified.

5.6 Systems incorporating structural restraint

5.6.1 Containers may be secured by the use of a fixed structure providing permanent buttresses in association with portable frameworks. Proposals to adopt such systems will be considered on the basis of the loads developed in the structure and the corresponding stresses.

5.6.2 The framework or other devices securing the containers are to be aligned with the container corner fittings and any clearance gap is to be kept to the minimum to reduce shifting.

■ *Section 6***Container securing arrangements for underdeck stowage without cell guides****6.1 General**

6.1.1 Containers are generally to be stowed in holds in the fore and aft direction, but alternative arrangements will be considered. The securing arrangements are to be designed on the basis of the most severe distribution of loads which may arise in the container stack.

6.1.2 Containers may be secured by locking devices only or by a combination of locking devices, buttresses, shores or lashings. Containers are, in general, to be restrained at every corner at the base of the stack and at all intermediate levels.

6.1.3 Where stacks consist of one or two tiers only, consideration will be given to the omission of corner locking devices. Containers must, however, be secured by a minimum of two corner locking devices.

6.1.4 Where the calculations indicate that separation forces could occur at any particular level, twistlocks or equivalent means of securing are to be fitted at that level. Elsewhere, consideration will be given to the use of double stacking cones.

6.1.5 Where the calculations indicate that separation forces will not occur between containers at any level, consideration will be given to the use of stacking cones in lieu of locking devices throughout.

6.1.6 Buttresses are generally to be of the tension and compression type and are to be provided with means of adjustment to ensure tightness when fitted in place. Where applicable, the attachment to the ship's structure is also to include means for vertical adjustment of the buttress to match container stacks of different heights.

6.1.7 Shores of the compression-only type may be permanently attached to the ship structure or they may be hinged or portable. When in place they are to abut the container corner fittings with minimal clearance. Means are to be provided to prevent slackening of the device.

6.1.8 Adjacent stacks of containers are to be linked in line with buttresses or shores in order to transmit lateral loads. The fittings used for these linkages are to be of adequate strength to transmit the loads imposed.

6.1.9 The ship's structure supporting shores and buttresses is to be reinforced as necessary.

6.1.10 Proposals for alternative securing systems, including systems relying on minimal clearance between containers and hull structure, will be specially considered.

6.1.11 Attention is drawn to the safety at work aspects for fittings which require operation on top of containers, e.g. double stacking cones, bridge fittings, buttresses and shores. Where these fittings are used, fall protection is to be provided.

■ *Section 7***Container securing arrangements for stowage using cell guides****7.1 General**

7.1.1 Cell guide systems may be fitted to support containers stowed in holds or on exposed decks.

7.1.2 The cell guides are not to form an integral part of the ship's structure. The guide system is generally to be so designed as to keep it free of the main hull stresses.

7.1.3 Cell guides are to be designed to resist loads caused by loading and unloading of the containers, to prevent shifting of the containers and to transmit the loads caused by motions of the ship into the main hull structure.

7.2 Arrangement and construction

7.2.1 Cell guides are to be of robust construction and generally fabricated from steel plate and rolled sections. They are to have sufficient vertical extent and continuity to provide efficient support to containers. Guide bars are to be effectively attached to the supporting structure to prevent tripping or distortion resulting from container loading.

7.2.2 The intersection between cell guide and cross ties is to provide adequate torsional stability.

7.2.3 Intermediate brackets are to be fitted to vertical cell guides at suitable intervals.

7.2.4 The cell guides are to give a total clearance between the container and guide bars not exceeding 25 mm in the transverse direction and 40 mm in the longitudinal direction. The deviation of the cell guide bar from its intended line is not generally to exceed 4 mm in the transverse direction and 5 mm in the longitudinal direction.

7.2.5 Athwartship cross ties are to be fitted between cell guides at a spacing determined from the loading on the guides but, generally, not more than 3,0 m apart. Wherever possible, cross ties are to be arranged in line with the corners of the containers as stowed and are to be supported against fore and aft movement at a minimum of two points across the breadth of the hold. Where, however, the maximum fore and aft deflection in the cross tie can be shown not to exceed 20 mm, one support point may be accepted.

7.2.6 Longitudinal tie bars may be required to be fitted where shown necessary by the force calculations for the structure. Where fitted, they are to comply with the requirements of *Pt 3, Ch 14, 7.2 Arrangement and construction 7.2.5*.

7.2.7 Where, at the sides or ends of holds, the guide rails are fitted to transverse or longitudinal bulkheads, the bulkhead is to be locally reinforced to resist the additional loads.

7.2.8 If the carriage of 45 ft Euro containers complying with EU Directive 96/53 is specified to be carried in 45 ft cell guides, attention is to be paid to the arrangement of the corner castings, see *Figure 14.7.1 45 ft euro container in cell guides*. The guide bars need to be increased in order to ensure that a minimum design overlap, a , of 20 mm is achieved, taking into account the design clearances and tolerances defined in *Pt 3, Ch 14, 7.2 Arrangement and construction 7.2.4*. Consideration is to be given to the torsional loads being applied to the guide bars.

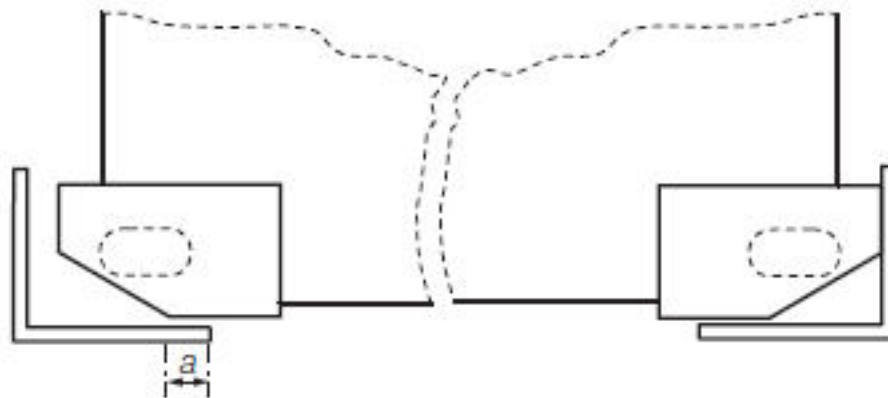

Figure 14.7.1 45 ft euro container in cell guides

7.3 Carriage of 20 ft containers in 40 ft cell guides in holds

7.3.1 Where the cell guides are arranged for the carriage of 40 ft containers, provision may be made for the installation of temporary intermediate cell guides for 20 ft containers. The permanent structure is to be designed such that it is suitable for either loading pattern.

7.3.2 Alternatively, permanent means for the support of 20 ft containers at the mid-length of a cell arranged for 40 ft containers will be considered. Such means may include the following:

- A pillar (inboard) and vertical rest bar (on the longitudinal bulkhead) against which the container stack may rest. The pillar is to be supported laterally by the deck structure over and is to be sufficiently stiff to control lateral deflection of the container stacks.
- Guide bars supported transversely by slim structure within the gap between containers and with longitudinal ties as necessary.

Details of proposals will be individually considered, taking into account the loads on the support structure and the resulting deflections.

7.3.3 Where it is desired to stow 20 ft containers without external support at the mid-bay location with or without 40 ft overstow, so-called 'mixed stowage' arrangements meeting the following requirements are applicable:

- (a) Maximum homogeneous container weights for 20 ft containers stowed in cell guides with no 40 ft container overstowed can be derived from *Table 14.7.1 Maximum container weights of ISO 1496-1:1990 20 ft containers stowed in 40 ft cell guides with no overstow; Container's rated Weight = 24 t* and *Table 14.7.1 Maximum container weights of ISO 1496-1:1990 20 ft containers stowed in 40 ft cell guides with no overstow; Container's rated Weight = 24 t*, depending on the transverse acceleration and the number of tiers in the stack.
- (b) Maximum homogeneous container weights for 20 ft containers stowed in cell guides with at least one 40 ft container overstowed can be derived from *Table 14.7.3 Maximum container weights of ISO 1496-1:1990 20 ft containers stowed in 40 ft cell guides with overstow*, depending on the transverse acceleration and the number of tiers in the stack.
- (c) *Table 14.7.1 Maximum container weights of ISO 1496-1:1990 20 ft containers stowed in 40 ft cell guides with no overstow; Container's rated Weight = 24 t* have been derived on the basis of all containers in a stack having the same homogeneous weight. Where it is intended to carry non-homogeneous mixed stowage stacks, containers heavier than specified in *Table 14.7.1 Maximum container weights of ISO 1496-1:1990 20 ft containers stowed in 40 ft cell guides with no overstow; Container's rated Weight = 24 t* can be loaded in the lower tiers provided that the total stack weight derived from the Tables is not exceeded. Furthermore, no container having a weight in excess of the maximum weight stated in the Tables is to be stowed on top of a lighter container. However, the total accumulated stack weight derived from the above mentioned Tables may be increased by loading the lowest container in the stack up to its maximum rated weight.
- (d) Means are to be provided to prevent transverse sliding of the bottom of the stacks of 20 ft containers at the mid-bay position. This is to be in the form of permanently attached chocks at the inner bottom or equivalent. The design clearance is to be the same as for the cell guides and in accordance with *Pt 3, Ch 14, 7.2 Arrangement and construction 7.2.4*.
- (e) Stacking cones are to be fitted at each corner between tiers of the 20 ft containers to prevent transverse and longitudinal sliding. In addition, where a 40 ft container is required to be stowed above 20 ft containers, stacking cones are to be fitted at the ends of the 40 ft container between the 40 ft container and the 20 ft containers below.
- (f) The 20 ft containers are to have closed steel walls and top (no open frame containers, e.g. tank or bulk containers).
- (g) The orientation of the containers is to be such that all front ends or door ends are facing in one direction.
- (h) Cones are to be fitted on the inner bottom in way of the cell guides to restrain container movement in the longitudinal direction.
- (i) The containers are to be stowed in the hold in block stowage. In general, free standing stacks due to adjacent empty stacks are to be avoided.

Proposals for stowage arrangements other than the above will be individually considered and are to be accompanied by supporting calculations.

Table 14.7.1 Maximum container weights of ISO 1496-1:1990 20 ft containers stowed in 40 ft cell guides with no overstow; Container's rated Weight = 24 t

Lowest tier transverse acceleration (= a √g), see Pt 3, Ch 14, 8.2 Ship motion, wind and green sea forces acting on containers 8.2.5	Maximum homogeneous container weights, in tonnes									
	3 tiers	4 tiers	5 tiers	6 tiers	7 tiers	8 tiers	9 tiers	10 tiers	11 tiers	12 tiers
0,350	24,0	24,0	24,0	20,2	17,3	14,8	13,4	11,6	10,6	9,5
0,355	24,0	24,0	24,0	20,2	17,1	14,6	13,3	11,6	10,6	9,4
0,360	24,0	24,0	24,0	19,7	16,9	14,5	13,2	11,5	10,5	9,3
0,365	24,0	24,0	24,0	19,5	16,7	14,3	13,1	11,4	10,4	9,3
0,370	24,0	24,0	23,9	19,3	16,5	14,1	13,0	11,3	10,3	9,2
0,375	24,0	24,0	23,6	19,0	16,3	14,0	12,9	11,3	10,3	9,2

Cargo Securing Arrangements

Part 3, Chapter 14

Section 7

0,380	24,0	24,0	23,3	18,8	16,1	13,8	12,7	11,2	10,2	9,1
0,385	24,0	24,0	23,0	18,6	15,9	13,6	12,6	11,1	10,1	9,0
0,390	24,0	24,0	22,7	18,4	15,8	13,5	12,5	11,0	10,0	9,0
0,395	24,0	24,0	22,5	18,2	15,6	13,3	12,4	10,9	9,9	8,9
0,400	24,0	24,0	22,2	18,0	15,4	13,2	12,3	10,8	9,9	8,9
0,405	24,0	24,0	22,0	17,8	15,3	13,1	12,1	10,7	9,8	8,8
0,410	24,0	24,0	21,8	17,6	15,1	13,0	12,0	10,7	9,7	8,8
0,415	24,0	24,0	21,5	17,5	15,0	12,9	11,8	10,6	9,7	8,7
0,420	24,0	24,0	21,3	17,3	14,8	12,7	11,7	10,4	9,6	8,7
0,425	24,0	24,0	21,1	17,2	14,7	12,6	11,5	10,3	9,5	8,6
0,430	24,0	24,0	20,9	17,0	14,6	12,5	11,4	10,2	9,4	8,6
0,435	24,0	24,0	20,7	16,9	14,5	12,4	11,3	10,1	9,4	8,5
0,440	24,0	24,0	20,6	16,8	14,4	12,4	11,1	10,0	9,3	8,5
0,445	24,0	23,9	20,4	16,6	14,3	12,3	11,0	9,9	9,2	8,4
0,450	24,0	23,7	20,2	16,5	14,1	12,2	10,9	9,9	9,2	8,3
0,455	24,0	23,6	20,0	16,4	14,0	12,1	10,8	9,8	9,1	8,3
0,460	24,0	23,4	19,9	16,2	13,9	12,0	10,7	9,7	9,0	8,2
0,465	24,0	23,3	19,7	16,1	13,8	11,9	10,6	9,6	8,9	8,1
0,470	24,0	23,1	19,6	16,0	13,7	11,8	10,6	9,5	8,9	8,1
0,475	24,0	23,0	19,5	15,9	13,6	11,7	10,5	9,4	8,8	8,0
0,480	24,0	22,9	19,3	15,8	13,5	11,6	10,5	9,4	8,7	7,9
0,485	24,0	22,7	19,2	15,7	13,4	11,5	10,4	9,3	8,6	7,9
0,490	24,0	22,6	19,1	15,6	13,3	11,4	10,3	9,2	8,5	7,8
0,495	24,0	22,5	18,9	15,5	13,2	11,3	10,3	9,1	8,5	7,7
0,500	24,0	22,4	18,8	15,4	13,1	11,2	10,2	9,1	8,4	7,7
0,505	24,0	22,3	18,7	15,3	13,0	11,2	10,1	9,0	8,3	7,6
0,510	24,0	22,1	18,6	15,2	13,0	11,1	10,1	8,9	8,3	7,6
0,515	24,0	22,0	18,4	15,1	12,9	11,0	10,0	8,9	8,2	7,5
0,520	24,0	21,9	18,3	15,0	12,8	10,9	9,9	8,8	8,1	7,4
0,525	24,0	21,8	18,2	14,9	12,7	10,9	9,9	8,7	8,1	7,4
0,530	24,0	21,7	18,1	14,8	12,6	10,8	9,8	8,7	8,0	7,3
0,535	24,0	21,6	18,0	14,7	12,5	10,7	9,7	8,6	8,0	7,3
0,540	24,0	21,5	17,9	14,6	12,4	10,6	9,6	8,5	7,9	7,2
0,545	24,0	21,4	17,7	14,5	12,3	10,6	9,6	8,5	7,8	7,1
0,550	24,0	21,3	17,6	14,4	12,3	10,5	9,5	8,4	7,8	7,1
0,555	24,0	21,2	17,5	14,3	12,2	10,4	9,4	8,4	7,7	7,0
0,560	24,0	21,1	17,4	14,2	12,1	10,4	9,3	8,3	7,7	7,0
0,565	24,0	21,0	17,3	14,2	12,0	10,3	9,3	8,3	7,6	6,9

0,570	24,0	20,9	17,2	14,1	11,9	10,2	9,2	8,2	7,6	6,9
0,575	24,0	20,8	17,1	14,0	11,9	10,2	9,1	8,2	7,5	6,8
0,580	24,0	20,7	17,0	13,9	11,8	10,1	9,0	8,1	7,5	6,8
0,585	24,0	20,6	16,9	13,8	11,7	10,1	9,0	8,1	7,4	6,8
0,590	24,0	20,5	16,8	13,7	11,6	10,0	8,9	8,0	7,4	6,7
0,595	24,0	20,4	16,7	13,7	11,6	9,9	8,8	8,0	7,3	6,7
0,600	24,0	20,4	16,6	13,6	11,5	9,9	8,8	7,9	7,3	6,6
0,605	24,0	20,3	16,5	13,5	11,4	9,8	8,7	7,9	7,2	6,6
0,610	24,0	20,2	16,5	13,4	11,4	9,8	8,7	7,8	7,2	6,5
0,615	24,0	20,1	16,4	13,4	11,3	9,7	8,6	7,8	7,1	6,5
0,620	24,0	20,0	16,3	13,3	11,2	9,7	8,6	7,7	7,1	6,5
0,625	24,0	20,0	16,2	13,2	11,2	9,6	8,6	7,7	7,0	6,4
0,630	24,0	19,9	16,1	13,1	11,1	9,6	8,5	7,6	7,0	6,4
0,635	24,0	19,8	16,0	13,1	11,1	9,5	8,5	7,6	6,9	6,3
0,640	24,0	19,7	15,9	13,0	11,0	9,5	8,4	7,5	6,9	6,3
0,645	24,0	19,7	15,9	12,9	10,9	9,4	8,4	7,5	6,9	6,3
0,650	24,0	19,6	15,8	12,9	10,9	9,4	8,4	7,5	6,8	6,2

Table 14.7.2 Maximum container weights of ISO 1496-1:1990 20 ft containers stowed in 40 ft cell guides with no overstow; Container's rated weight = 30,5 t

Lowest tier transverse acceleration (= a_y/g), see Pt 3, Ch 14, 8.2 Ship motion, wind and green sea forces acting on containers 8.2.5	Maximum homogeneous container weights, in tonnes									
	3 tiers	4 tiers	5 tiers	6 tiers	7 tiers	8 tiers	9 tiers	10 tiers	11 tiers	12 tiers
0,350	30,5	28,1	25,0	20,2	17,3	14,8	13,4	11,6	10,6	9,5
0,355	30,5	27,8	24,7	20,0	17,1	14,6	13,3	11,6	10,5	9,4
0,360	30,5	27,6	24,4	19,7	16,9	14,5	13,2	11,5	10,5	9,3
0,365	30,5	27,3	24,1	19,5	16,7	14,3	13,1	11,4	10,4	9,3
0,370	30,5	27,0	23,9	19,3	16,5	14,1	13,0	11,3	10,3	9,2
0,375	30,5	26,7	23,6	19,0	16,3	14,0	12,9	11,3	10,2	9,2
0,380	30,5	26,4	23,3	18,8	16,1	13,8	12,7	11,2	10,2	9,1
0,385	30,5	26,2	23,0	18,6	15,9	13,6	12,6	11,1	10,1	9,0
0,390	30,5	25,9	22,7	18,4	15,8	13,5	12,5	11,0	10,0	9,0
0,395	30,5	25,7	22,5	18,2	15,6	13,3	12,4	10,9	9,9	8,9
0,400	30,5	25,4	22,2	18,0	15,4	13,2	12,3	10,8	9,9	8,9
0,405	30,5	25,2	22,0	17,8	15,3	13,1	12,1	10,7	9,8	8,8

Cargo Securing Arrangements

Part 3, Chapter 14

Section 7

0,410	30,5	25,0	21,8	17,6	15,1	13,0	12,0	10,7	9,7	8,8
0,415	30,5	24,8	21,5	17,5	15,0	12,9	11,8	10,6	9,7	8,7
0,420	30,5	24,7	21,3	17,3	14,8	12,7	11,7	10,4	9,6	8,7
0,425	30,5	24,5	21,1	17,2	14,7	12,6	11,5	10,3	9,5	8,6
0,430	30,5	24,3	20,9	17,0	14,6	12,5	11,4	10,2	9,4	8,6
0,435	30,5	24,2	20,7	16,9	14,5	12,4	11,3	10,1	9,4	8,5
0,440	30,5	24,0	20,6	16,8	14,4	12,4	11,1	10,0	9,3	8,5
0,445	30,5	23,9	20,4	16,6	14,3	12,3	11,0	9,9	9,2	8,4
0,450	30,5	23,7	20,2	16,5	14,1	12,2	10,9	9,9	9,2	8,3
0,455	30,5	23,6	20,0	16,4	14,0	12,1	10,8	9,8	9,1	8,3
0,460	30,5	23,4	19,9	16,2	13,9	12,0	10,7	9,7	9,0	8,2
0,465	30,5	23,3	19,7	16,1	13,8	11,9	10,6	9,6	8,9	8,1
0,470	30,5	23,1	19,6	16,0	13,7	11,8	10,6	9,5	8,9	8,1
0,475	30,5	23,0	19,5	15,9	13,6	11,7	10,5	9,4	8,8	8,0
0,480	30,5	22,9	19,3	15,8	13,5	11,6	10,5	9,4	8,7	7,9
0,485	30,5	22,7	19,2	15,7	13,4	11,5	10,4	9,3	8,6	7,9
0,490	30,5	22,6	19,1	15,6	13,3	11,4	10,3	9,2	8,5	7,8
0,495	30,5	22,5	18,9	15,5	13,2	11,3	10,3	9,1	8,5	7,7
0,500	30,5	22,4	18,8	15,4	13,1	11,2	10,2	9,1	8,4	7,7
0,505	30,5	22,3	18,7	15,3	13,0	11,2	10,1	9,0	8,3	7,6
0,510	30,4	22,1	18,6	15,2	13,0	11,1	10,1	8,9	8,3	7,6
0,515	30,4	22,0	18,4	15,1	12,9	11,0	10,0	8,9	8,2	7,5
0,520	30,4	21,9	18,3	15,0	12,8	10,9	9,9	8,8	8,1	7,4
0,525	30,4	21,8	18,2	14,9	12,7	10,9	9,9	8,7	8,1	7,4
0,530	30,4	21,7	18,1	14,8	12,6	10,8	9,8	8,7	8,0	7,3
0,535	30,3	21,6	18,0	14,7	12,5	10,7	9,7	8,6	8,0	7,3
0,540	30,3	21,5	17,9	14,6	12,4	10,6	9,6	8,5	7,9	7,2
0,545	30,1	21,4	17,7	14,5	12,3	10,6	9,6	8,5	7,8	7,1
0,550	30,1	21,3	17,6	14,4	12,3	10,5	9,5	8,4	7,8	7,1
0,555	29,9	21,2	17,4	14,3	12,2	10,4	9,4	8,4	7,7	7,0
0,560	29,8	21,1	17,4	14,2	12,1	10,4	9,3	8,3	7,7	7,0
0,565	29,6	21,0	17,3	14,2	12,0	10,3	9,3	8,3	7,6	6,9
0,570	29,4	20,9	17,2	14,1	11,9	10,2	9,2	8,2	7,6	6,9
0,575	29,1	20,8	17,1	14,0	11,9	10,2	9,1	8,2	7,5	6,8
0,580	28,9	20,7	17,0	13,9	11,8	10,1	9,0	8,1	7,5	6,8
0,585	28,7	20,6	16,9	13,8	11,7	10,1	9,0	8,1	7,4	6,8
0,590	28,5	20,5	16,8	13,7	11,6	10,0	8,9	8,0	7,4	6,7
0,595	28,3	20,4	16,7	13,7	11,6	9,9	8,8	8,0	7,3	6,7

0,600	28,2	20,4	16,6	13,6	11,5	9,9	8,8	7,9	7,3	6,6
0,605	28,1	20,3	16,5	13,5	11,4	9,8	8,7	7,9	7,2	6,6
0,610	28,0	20,2	16,5	13,4	11,4	9,8	8,7	7,8	7,2	6,5
0,615	28,0	20,1	16,4	13,4	11,3	9,7	8,6	7,8	7,1	6,5
0,620	28,0	20,0	16,3	13,3	11,2	9,7	8,6	7,7	7,1	6,5
0,625	27,9	20,0	16,2	13,2	11,2	9,6	8,6	7,7	7,0	6,4
0,630	27,9	19,9	16,1	13,1	11,1	9,6	8,5	7,6	7,0	6,4
0,635	27,9	19,8	16,0	13,1	11,1	9,5	8,5	7,6	6,9	6,3
0,640	27,9	19,7	15,9	13,0	11,0	9,5	8,4	7,5	6,9	6,3
0,645	27,9	19,7	15,9	12,9	10,9	9,4	8,4	7,5	6,9	6,3
0,650	27,9	19,6	15,8	12,9	10,9	9,4	8,4	7,5	6,8	6,2

Table 14.7.3 Maximum container weights of ISO 1496-1:1990 20 ft containers stowed in 40 ft cell guides with overstow

Lowest tier transverse acceleration (= a_y/g), see Pt 3, Ch 14, 8.2 <i>Ship motion, wind and green sea forces acting on containers 8.2.5</i>	Maximum homogeneous container weights, in tonnes					
	3 tiers	4 tiers	5 tiers	6 tiers	7 tiers	8 tiers
0,400	24,0	24,0	24,0	19,6	17,1	15,2
0,405	24,0	24,0	23,6	19,4	17,0	15,1
0,410	24,0	24,0	23,3	19,2	16,8	14,9
0,415	24,0	24,0	22,9	19,1	16,7	14,8
0,420	24,0	24,0	22,5	18,9	16,5	14,7
0,425	24,0	24,0	22,1	18,8	16,4	14,5
0,430	24,0	24,0	21,8	18,6	16,2	14,4
0,435	24,0	24,0	21,5	18,4	16,1	14,3
0,440	24,0	24,0	21,2	18,3	15,9	14,1
0,445	24,0	24,0	21,0	18,1	15,8	14,0
0,450	24,0	24,0	20,8	18,0	15,7	13,9
0,455	24,0	24,0	20,6	17,8	15,5	13,7
0,460	24,0	24,0	20,5	17,7	15,4	13,6
0,465	24,0	24,0	20,3	17,5	15,2	13,5
0,470	24,0	24,0	20,2	17,3	15,1	13,3
0,475	24,0	24,0	20,1	17,2	14,9	13,2
0,480	24,0	23,9	19,9	17,0	14,8	13,1
0,485	24,0	23,8	19,8	16,9	14,6	12,9
0,490	24,0	23,6	19,6	16,7	14,5	12,8
0,495	24,0	23,4	19,4	16,5	14,3	12,7

0,500	24,0	23,2	19,3	16,4	14,2	12,5
0,505	24,0	23,1	19,1	16,2	14,1	12,4
0,510	24,0	22,9	18,9	16,1	13,9	12,2
0,515	24,0	22,7	18,8	15,9	13,8	12,1
0,520	24,0	22,5	18,6	15,7	13,6	12,0
0,525	24,0	22,4	18,5	15,6	13,5	11,8
0,530	24,0	22,3	18,3	15,4	13,3	11,7
0,535	24,0	22,2	18,2	15,3	13,2	11,6
0,540	24,0	22,1	18,1	15,1	13,0	11,4
0,545	24,0	22,0	18,0	15,0	12,9	11,3
0,550	24,0	21,8	17,9	14,8	12,8	11,2

Note 40ft overstow containers not included in the number of tiers.

7.4 Cell guide systems on exposed decks

7.4.1 Analysis methods for the strength of the cell guide structure are to take due account of the interactive effects between guide structure and supporting deck structure and also of the deformation of the hull girder.

7.4.2 At its lower end the guide structure is to be efficiently connected to the deck structure. Cross ties are to be arranged between guides in a transverse direction at a spacing determined by the loading on the guides but in general not more than 3 m apart. Cross-bracing members of adequate strength and sufficient number are to be fitted in the transverse and longitudinal directions to prevent excessive deflection of the guide structure.

7.4.3 The height of guide bars above the deck is to be sufficient to ensure adequate restraint to the uppermost container tiers.

7.4.4 Where the cell guide structure is attached to highly stressed hull or deck elements, such as sheerstrakes, special attention is to be given to the design of the connection and the grade and quality of steel utilised.

7.5 Entry guide devices

7.5.1 A device to pre-centre the container and direct it into the cell guides is normally to be fitted at the top of the guide bars. Such devices include:

- fixed even peaks,
- fixed high and low peaks,
- 'flip-flop' systems,

but other devices will be considered. The device is to be of robust construction.

■ Section 8 Determination of forces for container securing arrangements

8.1 General

8.1.1 The forces acting in the securing system are to be determined for each loading condition and associated set of motions of the ship. Although the operation of anti-roll devices or other systems may improve the behaviour of the ship in a seaway, the effect of such devices is not to be taken into account to reduce the determination of the forces for container securing arrangements.

8.1.2 The following forces are to be taken into account:

- Static gravity forces.
- Inertial forces generated by the ship motions in a seaway.

- Wind forces.
- Forces imposed by the securing arrangements.
- Wave impact forces and effects of consequential hull girder whipping.

8.1.3 Forces due to pre-tensioning the securing devices need not, in general, be included in the calculation, provided that they do not exceed 5 kN in any one item. Special consideration will be given to cases where forces obtained from pre-stressing are an integral part of the design of the system.

8.2 Ship motion, wind and green sea forces acting on containers

8.2.1 The forces acting on each container due to gravity, ship motion accelerations, ship rolling and pitching angles and wind forces and green sea forces are to be calculated as follows.

8.2.2 The ship motion amplitude and period for roll and pitch motions are given in *Table 14.8.1 Ship motions*. The equations for ship motion accelerations and other motion parameters are given in *Pt 3, Ch 14, 1.5 Symbols and definitions*. These are to be used for the calculation of accelerations to derive the forces for the container securing arrangements. Alternatively, the ship motion values may be derived by direct calculation methods using the same principles as those used to derive the Rule equations.

Table 14.8.1 Ship motions

Motion	Maximum single amplitude	Periods, in seconds
Roll	$\varphi = 55 f_{BK} f_{HsR} e^{(-0,025B)}$ <p>φ is not to be taken less than $f_{HsR} 22^\circ$ but need not exceed 30°</p>	$T_r = \frac{0,82B}{\sqrt{GM}}$
Pitch	$\psi = 1350L^{-0,94} \left(1,0 + \left(\frac{0,82}{\sqrt{L}} \right)^{1,2} \right) f_{HsP}$ <p>ψ need not exceed 8°</p>	$T_p = 0,5 \sqrt{L_{pp}}$ <p>where</p> $C_1 = 0,95 \text{ for MC1}$ $= 0,52 \text{ for all other Motion Cases}$

8.2.3 The following six Motion Cases (MCs) are to be considered:

- MC1: Head sea case that maximises vertical acceleration
- MC2: Beam sea case that maximises roll motion
- MC3: Oblique sea case that maximises pitch acceleration
- MC4: Oblique sea case with forward speed that maximises roll motion
- MC5: Oblique sea case that maximises combined transverse and vertical accelerations
- MC6: Beam sea case that maximises heave acceleration

Each Motion Case comprises 2 or 4 Motion Combination Factor (MCF) sets representing an incoming wave crest or trough coming from either the port or starboard sides. Each MCF set represents an Equivalent Design Wave (EDW) that generates response values equivalent to the long-term response values of the critical load components for ship motion forces acting on containers. The Motion Combination Factors are given in *Table 14.8.4 Motion Combination Factors (MCFs)*.

8.2.4 The individual force components for each Motion Case due to gravity, ship motions, wind and green seas acting on a container *i* are to be determined as follows, see *Figure 14.1.1 Diagrammatic representation of symbols* and *Figure 14.9.1 Force derivation at one end of a three-tier stack*:

$$H_{Di} = \text{force acting on container } i \text{ in kN in transverse direction parallel to deck, positive to port}$$

$$= W a_y + H_{Gi}$$

J_{Di} = force acting on container i in kN in longitudinal direction parallel to deck, positive forward

$$= W a_x + J_{Gi}$$

P_{Di} = upwards force acting on container i in kN normal to deck

$$= W a_z + P_{Gi}$$

Q_{Di} = wind force acting on exposed container i in kN in transverse direction parallel to deck

$$= C_{wf} b c_i V_W^2 \cos^2(C_{yG} \varphi) \times 10^{-4}$$

where

C_{wf} is given in Table 14.8.2 Wind force coefficient C_{wf} and C_{yG} is given in Table 14.8.4 Motion Combination Factors (MCFs)

Note 1. Q_{Di} is only to be applied when Q_{Di} will increase the transverse force H_{Di} .

Note 2. When the green sea force H_{Gi} is also applicable, the wind force is only to be applied to container i when the wind force Q_{Di} is greater than the green sea force H_{Gi} acting on container i . In this case the wind force is to be reduced such that the total combined green sea and wind force is not greater than the originally calculated wind force.

Note 3. See also Pt 3, Ch 14, 8.2 Ship motion, wind and green sea forces acting on containers 8.2.6 and Pt 3, Ch 14, 8.2 Ship motion, wind and green sea forces acting on containers 8.2.7.

H_{Gi} = green sea force acting on container i , in kN in transverse direction parallel to deck, positive to port

$$= -b c_i P_{gs} \text{ for port side exposed containers}$$

$$= b c_i P_{gs} \text{ for starboard side exposed containers}$$

J_{Gi} = green sea force acting on container i , in kN in longitudinal direction parallel to deck, positive forward

$$= -a c_i P_{gs}$$

P_{Gi} = green sea force acting on container i , in kN in the upwards direction normal to deck

$$= 1,5a b$$

where

P_{gs} = green sea pressure in kN/m², see Pt 3, Ch 14, 8.2 Ship motion, wind and green sea forces acting on containers 8.2.8 and Pt 3, Ch 14, 8.2 Ship motion, wind and green sea forces acting on containers 8.2.9.

Table 14.8.2 Wind force coefficient C_{wf}

Motion Case see Note 1	Wind force coefficient C_{wf}	
	Incoming wave from port (1P and 2P cases)	Incoming wave from starboard (1S and 2S cases)
	Only applied to the port exposed faces of containers, see Note 3	Only applied to the starboard exposed faces of containers, see Note 3
MC1, see Note 2	0	0
MC2	-8,25	8,25

MC3	-7,18	7,18
MC4	-7,18	7,18
MC5	-7,18	7,18
MC6	-8,25	8,25

Note 1. For definition of Motion Cases, see Pt 3, Ch 14, 8.2 Ship motion, wind and green sea forces acting on containers 8.2.7.

Note 2. No wind loads are to be applied to Motion Case MC1.

Note 3. For definition of exposed faces, see Pt 3, Ch 14, 8.2 Ship motion, wind and green sea forces acting on containers 8.2.7.

8.2.5 The total instantaneous acceleration values acting on container i , including the static gravitational term, are to be taken as:

- Longitudinal acceleration (parallel to deck, positive forward)

$$a_x = C_{xS} a_{\text{surge}} + C_{xP} a_{\text{pitch}} z_i - g \sin(C_{xG} \psi) \text{ m/s}^2$$

- Transverse acceleration (parallel to deck, positive to port)

$$a_y = C_{yS} a_{\text{sway}} - C_{yR} a_{\text{roll}} z_i + g \sin(C_{yG} \phi) \text{ m/s}^2$$

- Vertical acceleration (normal to deck, positive upwards)

$$a_z = C_{p1} (C_{zH} a_{\text{heave}} + C_{zR} a_{\text{roll}} y_i - f_{\text{ap}} C_{zP} a_{\text{pitch}} x_i) - g \cos(C_{xG} \psi) \cos(C_{yG} \phi) \text{ m/s}^2$$

where the Motion Combination Factors C_{xS} , C_{xP} , C_{xG} , C_{yS} , C_{yR} , C_{yG} , C_{zH} , C_{zR} and C_{zP} for each Motion Case are given in Table 14.8.4 Motion Combination Factors (MCFs).

8.2.6 Wind forces are generally to be based on a maximum wind speed, V_w , of 40 m/s. Only positive forces of wind pressure are to be applied; suction forces need not be included.

8.2.7 Wind forces are to be taken as acting athwartships on the exposed faces of the container stack. Where the air gap between adjacent rows of containers does not exceed one metre, wind forces on the adjacent inner stack may be taken as zero. Where the air gap is 5 m or more, the adjacent inner stack is to be treated as fully exposed. Wind forces on the inner stack for intermediate air gaps may be obtained by linear interpolation, see Figure 14.8.1 Application of wind forces.

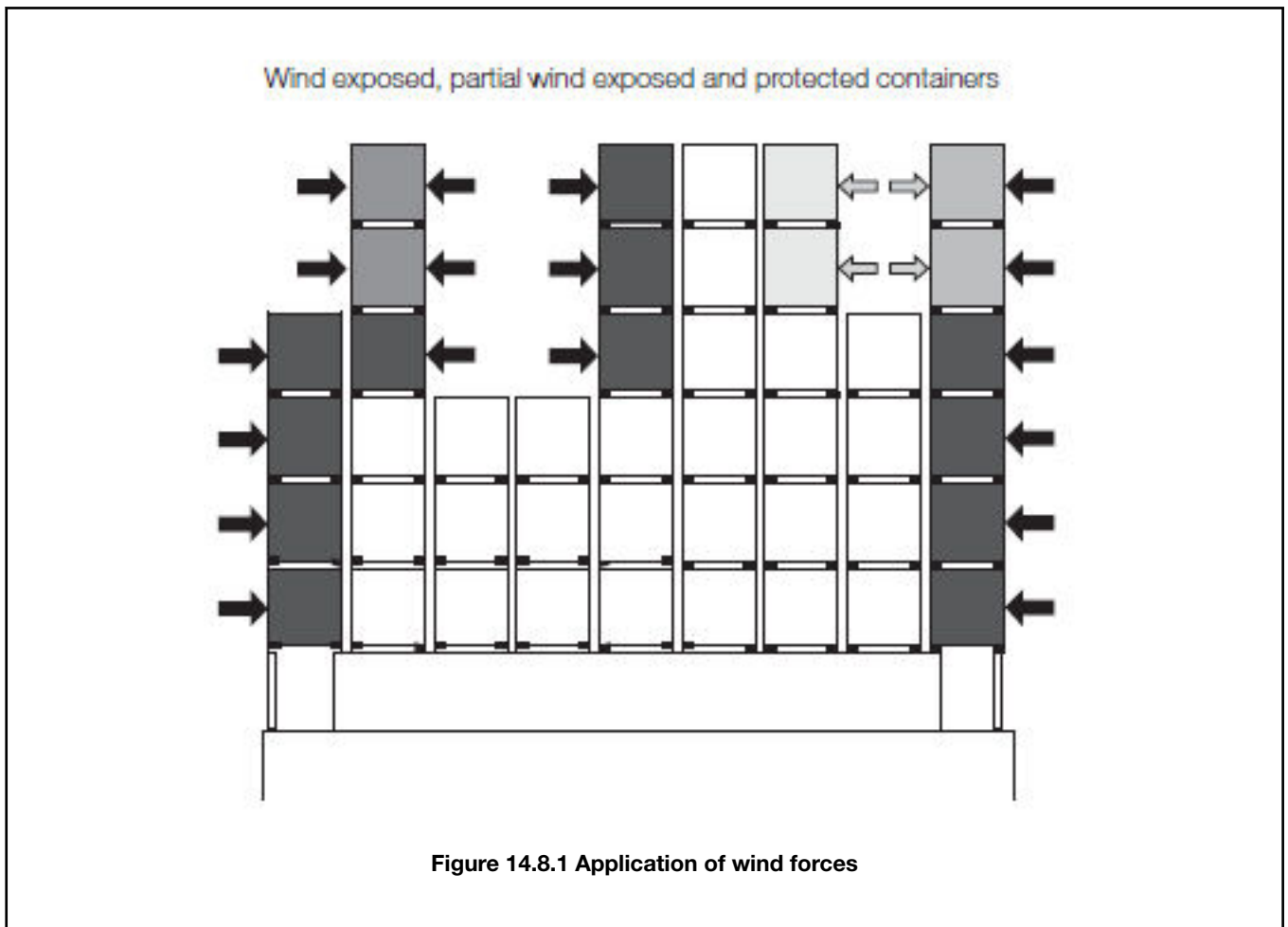

8.2.8 The green sea force is to be applied as follows, see *Figure 14.8.2 Example of application of green sea forces*:

- When the transverse force H_{Di} is acting inwards, the green sea force H_{Gi} is to be added to H_{Di} for each container in the lowest three tiers of the outermost two stack positions where $x_c > 0,75L$, unless they are protected by another container or effective wraparound breakwater or equivalent.
- When the longitudinal force J_{Di} is acting aftwards, the green sea force J_{Gi} is to be added to J_{Di} for each container in the lowest three tiers where $x_c > 0,75L$, unless the forward end of the container is protected by another container or effective breakwater or equivalent.
- When the vertical acceleration $a_z > -9,81\text{m/s}^2$ (less than g), the green sea force P_{Gi} is to be added to P_{Di} on the exposed underside of the lowest outboard container where $x_c > 0,75L$. The underside is considered exposed if it is raised above the hatch cover or deck by more than 0,5 m and not protected by an effective breakwater or equivalent.

Note In general, Tier 1 position corresponds to lowest tier of containers sitting just above the deck and Tier 2 position corresponds to the lowest tier of containers sitting just above the hatch covers, see *Figure 14.8.2 Example of application of green sea forces*.

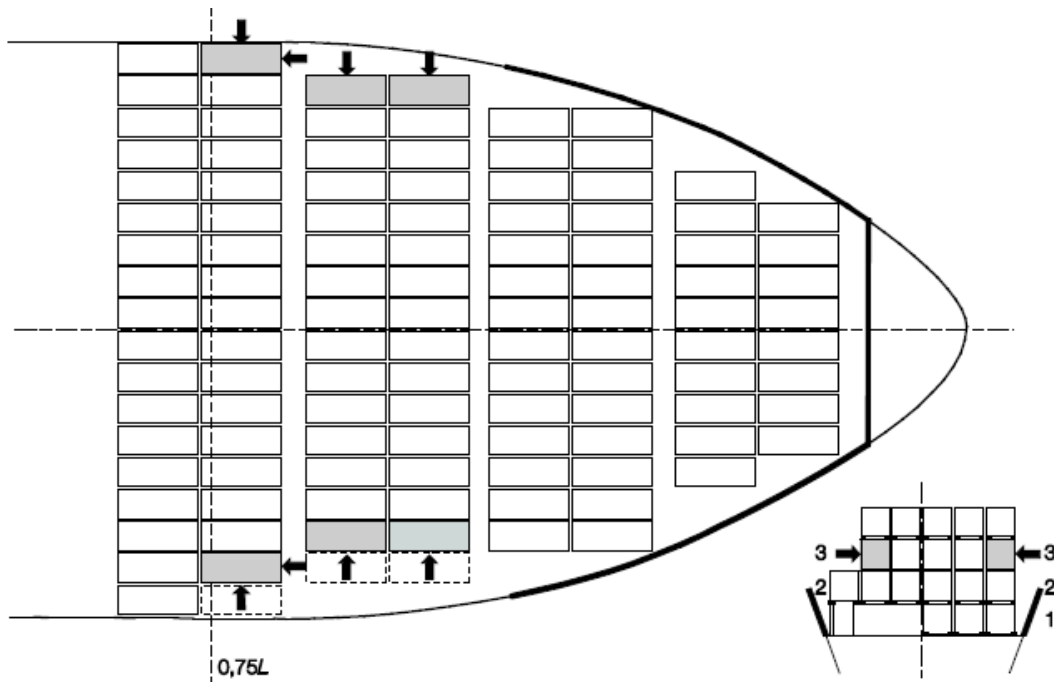

(a) Green sea loading on lowest three tiers only – Effective breakwaters (Forward and wrap around)

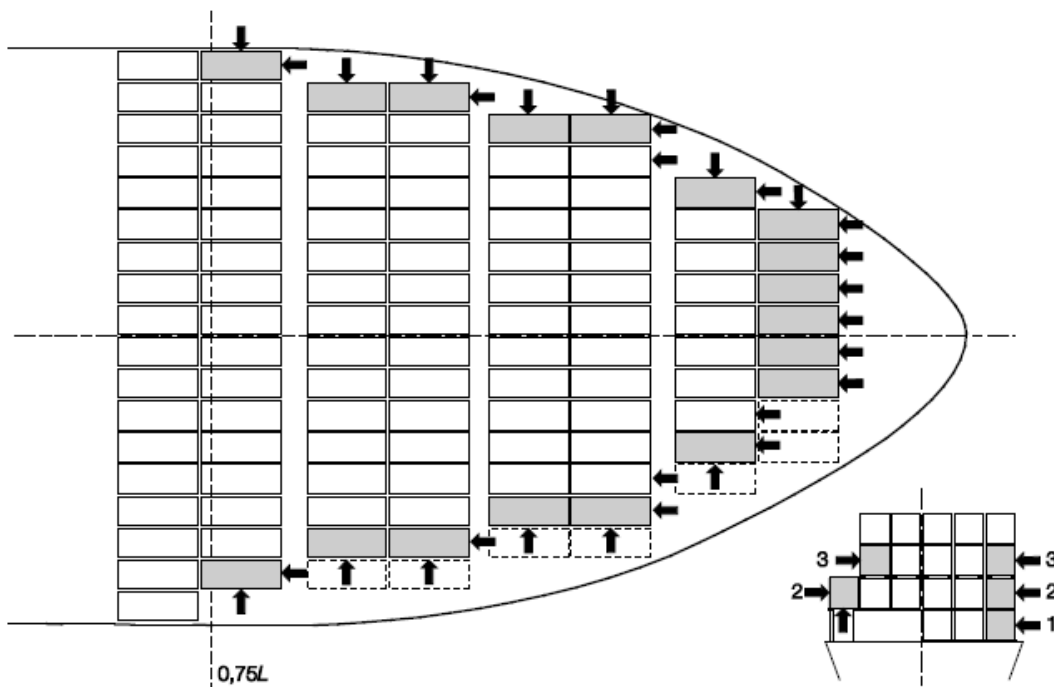

(b) Green sea loading on lowest three tiers only – No effective breakwater

Fig. 14.8.2 Example of application of green sea forces

Figure 14.8.2 Example of application of green sea forces

8.2.9 The green sea pressure is given by:

for $L > 100$

$$P_{gs} = C_{G1} L^2 + C_{G2} L + C_{G3} \text{ kN/m}^2 \text{ but not less than 0}$$

for $L \leq 100$, P_{gs} is to be taken as:

$$= 1,5 \text{ for Tier 1}$$

$$= 1,0 \text{ for Tier 2}$$

$$= 0,5 \text{ for Tier 3}$$

where

C_{G1} , C_{G2} , C_{G3} are defined in *Table 14.8.3 Green sea pressure coefficients*

Proposals to use other values for green sea forces will be specially considered

Table 14.8.3 Green sea pressure coefficients

	C_{G1}	C_{G2}	C_{G3}
Tier 1	-0,000017	0,0035	1,32
Tier 2	-0,000020	0,0040	0,80
Tier 3	-0,000023	0,0045	0,28

Table 14.8.4 Motion Combination Factors (MCFs)

Motion Case	Heading	Incoming wave	MCF	Longitudinal acceleration			Transverse acceleration			Vertical acceleration		
				a-surge	a-pitch	$g^* \sin \psi$	a-sway	a-roll	$g^* \sin \phi$	a-heave	a-roll	a-pitch
				C_{xS}	C_{xP}	C_{xG}	C_{yS}	C_{yR}	C_{yG}	C_{zH}	C_{zR}	C_{zP}
MC1	Head	From Bow	HS_1	-0,69	1,00	-0,85	0,00	0,00	0,00	-0,18	0,00	1,00
			HS_2	0,69	-1,00	0,85	0,00	0,00	0,00	0,18	0,00	-1,00
MC2	Beam	From PS	BS_1P	0,00	0,00	0,00	-0,09	0,66	-0,66	0,14	0,66	0,00
			BS_2P	0,00	0,00	0,00	0,09	-0,66	0,66	-0,14	-0,66	0,00
		From STB	BS_1S	0,00	0,00	0,00	0,09	-0,66	0,66	0,14	-0,66	0,00
			BS_2S	0,00	0,00	0,00	-0,09	0,66	-0,66	-0,14	0,66	0,00
MC3	Oblique	From PS	OS1_1P	-0,43	1,00	-0,86	-0,28	-0,22	0,05	-0,29	-0,22	1,00
			OS1_2P	0,43	-1,00	0,86	0,28	0,22	-0,05	0,29	0,22	-1,00
		From STB	OS1_1S	-0,43	1,00	-0,86	0,28	0,22	-0,05	-0,29	0,22	1,00
			OS1_2S	0,43	-1,00	0,86	-0,28	-0,22	0,05	0,29	-0,22	-1,00
MC4	Oblique	From PS	OS2_1P	0,00	0,00	0,00	-0,02	1,00	-1,00	0,00	1,00	0,00
			OS2_2P	0,00	0,00	0,00	0,02	-1,00	1,00	0,00	-1,00	0,00
		From STB	OS2_1S	0,00	0,00	0,00	0,02	-1,00	1,00	0,00	-1,00	0,00
			OS2_2S	0,00	0,00	0,00	-0,02	1,00	-1,00	0,00	1,00	0,00
MC5	Oblique	From PS	OS3_1P	0,62	-0,46	0,65	0,96	-0,36	0,12	0,11	-0,36	-0,46
			OS3_2P	-0,62	0,46	-0,65	-0,96	0,36	-0,12	-0,11	0,36	0,46
		From STB	OS3_1S	0,62	-0,46	0,65	-0,96	0,36	-0,12	0,11	0,36	-0,46
			OS3_2S	-0,62	0,46	-0,65	0,96	-0,36	0,12	-0,11	-0,36	0,46
MC6	Beam	From PS	BS2_1P	-0,07	-0,05	0,02	0,62	0,12	-0,01	1,00	0,12	-0,05
			BS2_2P	0,07	0,05	-0,02	-0,62	-0,12	0,01	-1,00	-0,12	0,05
		From STB	BS2_1S	-0,07	-0,05	0,02	-0,62	-0,12	0,01	1,00	-0,12	-0,05
			BS2_2S	0,07	0,05	-0,02	0,62	0,12	-0,01	-1,00	0,12	0,05

Section 9
Strength of container securing arrangements

9.1 General

9.1.1 The securing system is to be designed on the basis of the most severe combination of the forces specified in *Pt 3, Ch 14, 8 Determination of forces for container securing arrangements* in such a manner that the resultant forces on the containers and securing devices are within allowable limits. Where different arrangements of securing devices are proposed for different locations on the ship, the forces are to be calculated for the most severe condition applicable to each arrangement.

9.1.2 The resultant forces in the containers are not to exceed the allowable values given in *Pt 3, Ch 14, 9.6 Allowable forces on containers*.

9.1.3 The resultant forces in the securing devices and supports are not to exceed the allowable working loads for which the device has been approved, see *Pt 3, Ch 14, 2 Fixed cargo securing fittings, materials and testing* and *Pt 3, Ch 14, 3 Loose container securing fittings, materials and testing*.

9.1.4 The forces in lashing devices, where fitted, are not to exceed the allowable safe working loads (SWLs) of the lashings as determined from *Pt 3, Ch 14, 3 Loose container securing fittings, materials and testing*.

9.2 Applied forces to each container

9.2.1 The applied forces due to ship motion and environmental loads acting on each container in the stack in accordance with *Pt 3, Ch 14, 8 Determination of forces for container securing arrangements* are illustrated in *Figure 14.9.1 Force derivation at one end of a three-tier stack* and are assumed to be divided equally between the walls of the container, as follows:

$$H_i = \text{transverse force on each end wall} = \frac{H_{Di}}{2} \text{ kN}$$

$$J_i = \text{longitudinal force on each side wall} = \frac{J_{Di}}{2} \text{ kN}$$

$$P_i = \text{vertical downwards force at the bottom of each corner post} = \frac{-P_{Di}}{4} \text{ kN}$$

$$Q_i = \text{wind force on each end wall} = \frac{Q_{Di}}{2} \text{ kN}$$

The subscript *i* refers to any particular container.

9.2.2 Forces H_i and J_i are assumed to act at one third of the height of the container above its base. These forces are distributed as follows:

$$\frac{H_i}{3} \left(\text{or } \frac{J_i}{3} \right) \text{ acting at the top of the container, and}$$

$$\frac{2H_i}{3} \left(\text{or } \frac{2J_i}{3} \right) \text{ acting at the bottom.}$$

9.2.3 Wind force is assumed to be uniformly distributed over the side of the container and is therefore divided equally between the top and bottom of the container.

9.3 Total resulting forces in an unlashd stack

9.3.1 Where the stack is supported only by approved devices between the tiers of containers and at the base of the stack, the total forces in the stack are determined from *Table 14.9.1 Total resulting forces in each end/side wall of an unlashd stack*. *Figure 14.9.1 Force derivation at one end of a three-tier stack* illustrates the applied forces acting on each container and the resulting total forces.

Table 14.9.1 Total resulting forces in each end/side wall of an unlashed stack

Force	Equations for an unlashed stack
(a) Racking force in end/side wall of container <i>i</i>	
Transverse	$RA_{yi} = \sum_{j=i}^N F_j \text{ kN}$ <p>where the transverse force at level <i>j</i> is given by</p> $F_j = \frac{2H_{(j+1)}}{3} + \frac{H_j}{3} + \frac{Q_{(j+1)}}{2} + \frac{Q_j}{2} \text{ kN for } j < N \text{ and}$ $F_j = \frac{H_j}{3} + \frac{Q_j}{2} \text{ kN for } j = N$
Longitudinal	$RA_{xi} = \sum_{j=i}^n G_j \text{ kN}$ <p>where the longitudinal force at level <i>j</i> is given by</p> $G_j = \frac{2J_{(j+1)}}{3} + \frac{J_j}{3} \text{ kN for } j < N \text{ and}$ $G_j = \frac{J_j}{3} \text{ kN for } j = N$
(b) Shear force acting at bottom corner device of container <i>i</i>	
Transverse	$SF_{yi} = 0,55 \sum_{j=i}^N (H_j + Q_j) \text{ kN}$
Longitudinal	$SF_{xi} = 0,55 \sum_{j=i}^N J_j \text{ kN}$
Total shear force	$SF_i = \sqrt{SF_{xi}^2 + SF_{yi}^2} \text{ kN}$
(c) Compressive force in each corner post of container <i>i</i>	
Port fwd	$V_{pfi} = \sum_{j=i}^N P_j + \frac{1}{a} \sum_{j=i}^N F_j h_{ij} + \frac{1}{b} \sum_{j=i}^N G_j h_{ij} \text{ kN}$
Port aft	$V_{pai} = \sum_{j=i}^N P_j + \frac{1}{a} \sum_{j=i}^N F_j h_{ij} - \frac{1}{b} \sum_{j=i}^N G_j h_{ij} \text{ kN}$
Starboard fwd	$V_{sfi} = \sum_{j=i}^N P_j - \frac{1}{a} \sum_{j=i}^N F_j h_{ij} + \frac{1}{b} \sum_{j=i}^N G_j h_{ij} \text{ kN}$

Cargo Securing Arrangements

Part 3, Chapter 14

Section 9

Starboard aft	$V_{\text{sai}} = \sum_{j=i}^N P_j - \frac{1}{a} \sum_{j=i}^N F_j h_{ij} - \frac{1}{b} \sum_{j=i}^N G_j h_{ij} \text{ kN}$
Symbols	
<p>h_{ij} is the height from the bottom of the fitting (e.g. twistlock) below corner post i to the top of container j, in metres</p> $h_{ij} = \sum_{k=i}^J (c_k + d_k)$ <p>N is the total numbers of tiers</p> <p>Q_j is only applied to the exposed container faces</p>	

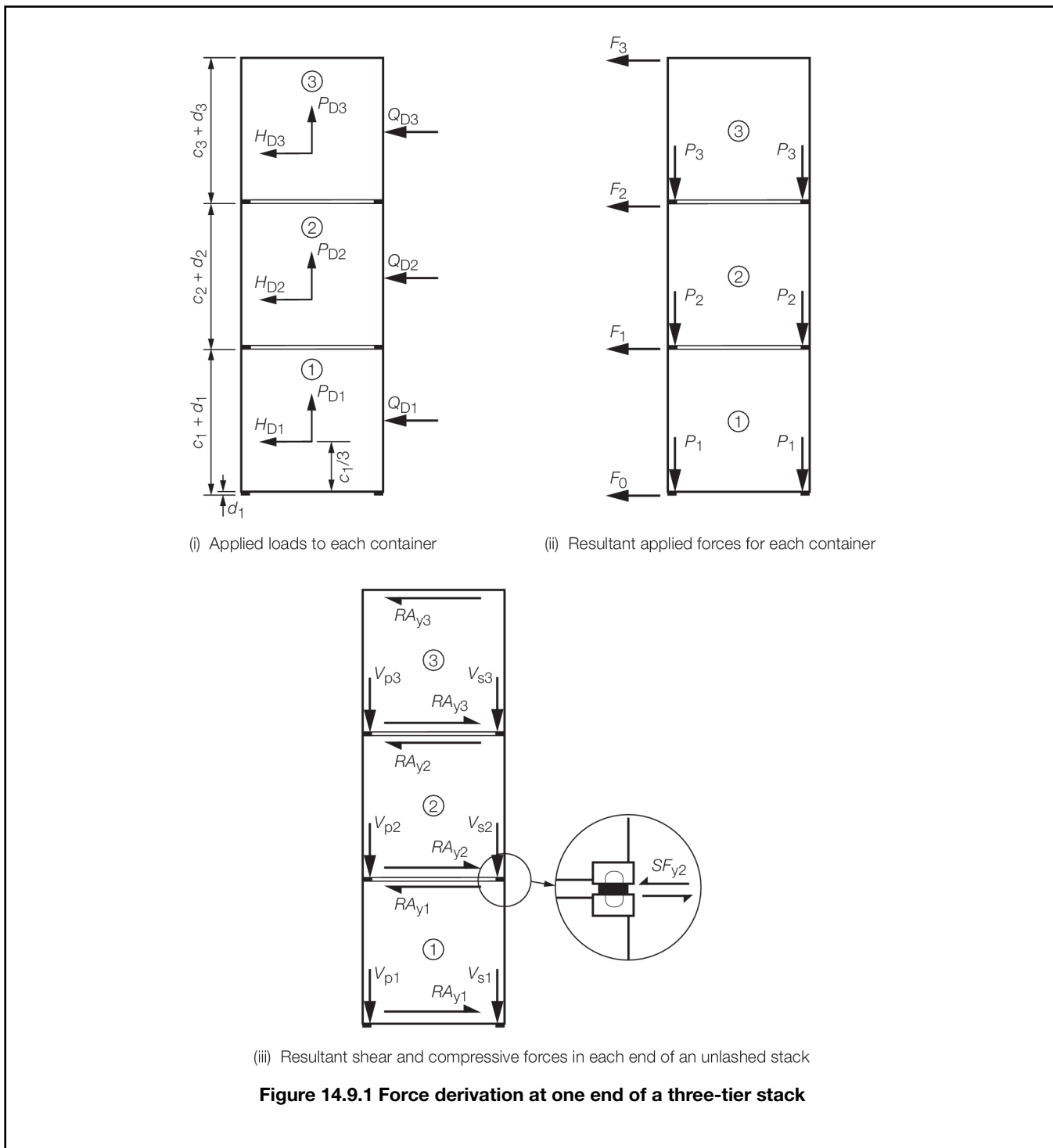

9.3.3 For exposed stacks forward of $0,75L$, see Pt 3, Ch 14, 8.2 Ship motion, wind and green sea forces acting on containers 8.2.6.

9.3.4 To illustrate this calculation, the equations for calculation of the transverse forces only for the three-tier stack shown in Figure 14.9.1 Force derivation at one end of a three-tier stack are listed below. For simplicity, the equations below do not include the longitudinal forces. The complete method to combine longitudinal and transverse forces for an unlashed stack is given in Table 14.9.1 Total resulting forces in each end/side wall of an unlashed stack.

(a) Transverse racking force in each end wall:

$$\text{Tier 3: } RA_{y3} = F_3$$

Tier 2: $RA_{y2} = F_3 + F_2$

Tier 1: $RA_{y1} = F_3 + F_2 + F_1$

(b) Transverse shear force at each bottom corner fitting:

Tier 3: $SF_{y3} = 0,55 (H_3 + Q_3)$

Tier 2: $SF_{y2} = 0,55 (H_3 + H_2 + Q_3 + Q_2)$

Tier 1: $SF_{y1} = 0,55 (H_3 + H_2 + H_1 + Q_3 + Q_2 + Q_1)$

(c) Compressive force at bottom of each port side corner post (i.e. force on the container below):

Tier 3: $V_{p3} = P_3 + \frac{F_3}{a} (c_3 + d_3)$

Tier 2: $V_{p2} = P_3 + P_2 + \frac{F_3}{a} (c_3 + c_2 + d_3 + d_2) + \frac{F_2}{a} (c_2 + d_2)$

Tier 1: $V_{p1} = P_3 + P_2 + P_1 + \frac{F_3}{a} (c_3 + c_2 + c_1 + d_3 + d_2 + d_1) + \frac{F_2}{a} (c_2 + c_1 + d_2 + d_1) + \frac{F_1}{a} (c_1 + d_1)$

(d) Compressive force at bottom of each starboard side corner post (i.e. force on the container below):

Tier 3: $V_{s3} = P_3 - \frac{F_3}{a} (c_3 + d_3)$

Tier 2: $V_{s2} = P_3 + P_2 - \frac{F_3}{a} (c_3 + c_2 + d_3 + d_2) - \frac{F_2}{a} (c_2 + d_2)$

Tier 1: $V_{s1} = P_3 + P_2 + P_1 - \frac{F_3}{a} (c_3 + c_2 + c_1 + d_3 + d_2 + d_1) - \frac{F_2}{a} (c_2 + c_1 + d_2 + d_1) - \frac{F_1}{a} (c_1 + d_1)$

A negative value in equations Pt 3, Ch 14, 9.3 Total resulting forces in an unlashed stack 9.3.4 and Pt 3, Ch 14, 9.3 Total resulting forces in an unlashed stack 9.3.4 indicates a separation force at that level.

9.3.5 The transverse displacements of the container stack are to be calculated as follows. The displacement of the top corner of container *i* under the actions of the applied forces is given by:

$$\delta_{yi} = \sum_{j=1}^i \left(\frac{RA_{yi}}{k_{cy}} \right) \text{ mm}$$

δ_{yi} is to be calculated for each end wall of the container

where

RA_{yi} = transverse racking force in end wall of container *i*, see also Table 14.9.1 Total resulting forces in each end/side wall of an unlashed stack

$$= \sum_{j=1}^N F_j \text{ kN}$$

k_{cy} = shear spring stiffness of the end wall being considered, see Table 14.9.2 Shear spring stiffness of container walls.

Table 14.9.2 Shear spring stiffness of container walls

Container height, metres	Door end kN/mm	Closed end kN/mm	Side wall kN/mm
2,438 (8 ft)	3,7	16,7	6,1
2,591 (8 ft 6 in)	3,5	15,4	5,7
2,743 (9 ft)	3,3	14,3	5,4
2,896 (9 ft 6 in)	3,2	13,3	5,1

9.3.6 The longitudinal displacements of the container stack are to be calculated as follows. The displacement of the top corner of container *i* under the actions of the applied forces is given by:

$$\delta_{xi} = \sum_{j=1}^i \left(\frac{RA_{xj}}{k_{cx}} \right) \text{ mm}$$

δ_{xi} is to be calculated for each side wall of the container.

9.4 Total resulting forces in a stack incorporating lashings

9.4.1 Where the securing arrangements incorporate lashings, proper allowance is to be made for flexibility of the system. For this purpose, the following values may be adopted:

- (a) **Racking deformation of the container.** Full scale testing of containers indicates that values of the shear spring stiffness constant (see Figure 14.9.2 Example of lashings at one end of a four-tier stack) may be taken as in Table 14.9.2 Shear spring stiffness of container walls.
- (b) **Horizontal movement of the containers.** Initial displacement of containers due to tolerances in container fittings will be considered in conjunction with the stowage arrangement proposed. Generally, initial displacement may be neglected in calculation procedures for conventional stowages.
- (c) **Elongation of the lashings.** Elongation may be determined by reference to an effective cross-sectional area of lashing device and an effective modulus of elasticity of the lashing (allowance for straightening and stretching), which in the absence of actual test values may be taken as specified in Table 14.9.3 Effective modulus of elasticity of lashing devices.

Table 14.9.3 Effective modulus of elasticity of lashing devices

Lashing equipment	Effective modulus of elasticity (E_i) see Pt 3, Ch 14, 9.5 Forces in the lashing devices 9.5.2
Steel rod lashings of hook type, including turnbuckle	98 kN/mm ²
Short (one tier) steel rod lashings (knob type), including turnbuckle and lashing eyes	140 kN/mm ²
Long (two tier) steel rod lashings (knob type), including turnbuckle and lashing eyes	175 kN/mm ²
Steel wire rope lashings	90 kN/mm ²
Steel chain lashings (based on the nominal diameter of the chain)	80 kN/mm ²
Adjustable tension/compression buttress	120 kN/mm ²
Aluminium or other materials	To be specially considered

9.4.2 Any other element introducing flexibility into the structure between the lashing point and the base of the container stack is to be evaluated and taken into account, if necessary. Examples of this could be flexibility of a lashing bridge, sliding of a hatch cover or torsional deformations of the hull.

9.4.3 The following lashing devices may be used:

- A shore device or similar that only accepts compressive loads, see Pt 3, Ch 14, 6.1 General 6.1.7. This may be modelled in a similar way to a lashing rod. However, where more than one stack is supported by the use of linkages between adjacent containers in line with the shore, the calculation model is to take this into account.
- A lashing bridge to allow lashing devices to be arranged high up in the container stack. Where open framework systems are fitted on deck to provide structural restraint, they are to be designed to absorb the full horizontal component of force at that

level and to prevent movement of the container stack. For the purpose of these calculations, the deformation of the ship's structure in way of supports may be neglected.

- A buttress connection or tension/compression device that accepts compressive and tensile forces, see Pt 3, Ch 14, 6.1 General 6.1.6. These are normally used for hold stowage. Where more than one stack is supported by the use of linkages between adjacent containers in line with the buttress, the calculation model is to take this into account.

9.4.4 The applied forces due to ship motion and environmental loads on containers in the stack are to be determined in accordance with Pt 3, Ch 14, 9.2 Applied forces to each container.

9.4.5 The tensile or compressive forces in lashing devices supporting the container stack are to be determined in accordance with Pt 3, Ch 14, 9.5 Forces in the lashing devices.

9.4.6 The load system for a four-tier stack of containers with transverse upper and lower lashings is illustrated in Figure 14.9.2 Example of lashings at one end of a four-tier stack. The containers and lashings are modelled as a system of springs whose stiffness may be calculated and hence the equilibrium condition for the system may be found, see Figure 14.9.2 Example of lashings at one end of a four-tier stack.

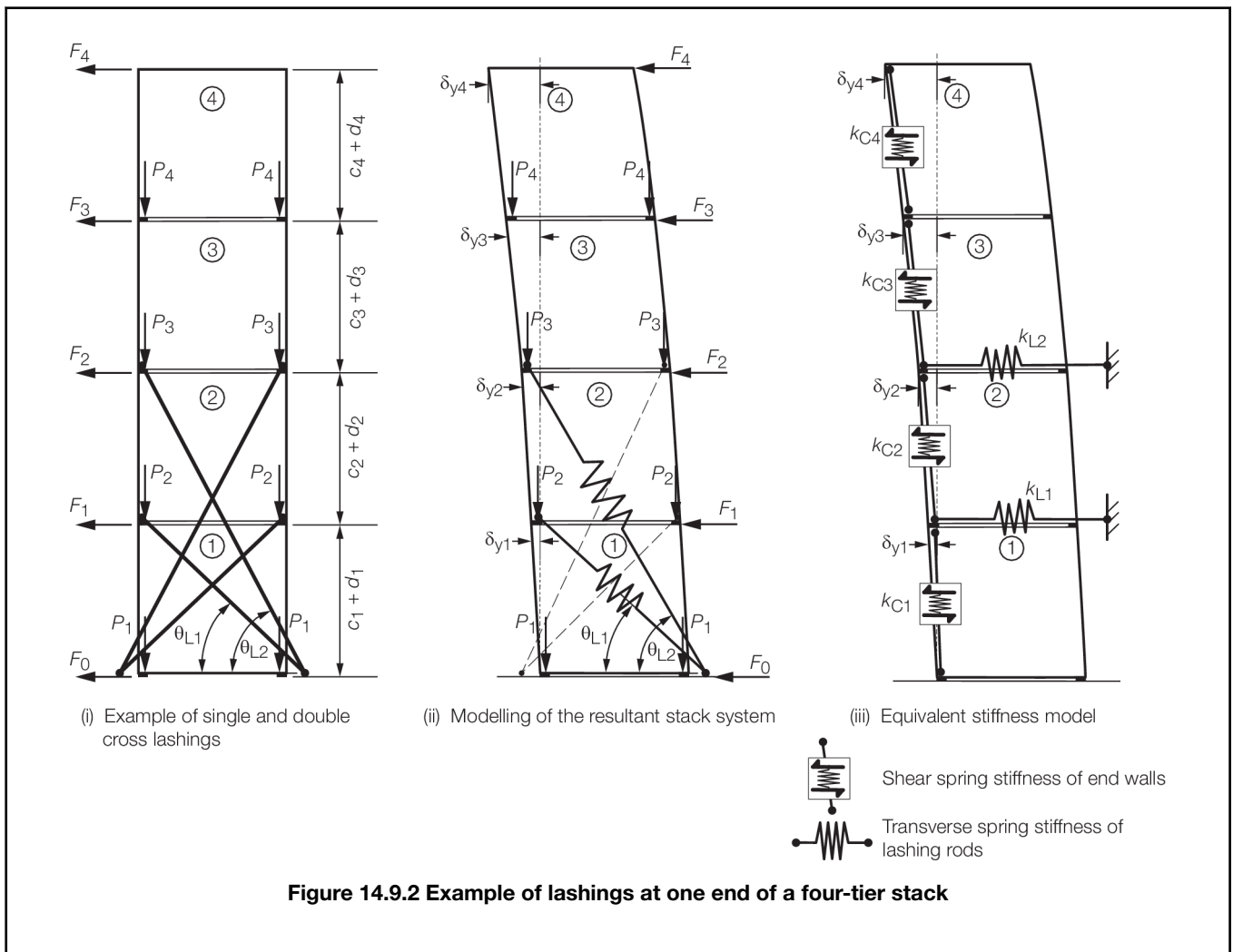

9.4.7 The calculations are to be made for each end of the container stack, that is, with all door ends together and with all closed ends together, and also for each side wall.

9.4.8 The transverse displacements of the container stack are to be calculated as follows. The displacement of the top corner of container *i* under the actions of the applied forces and supporting lashing devices is given by:

$$\delta_{yi} = \sum_{j=1}^i \left(\frac{RA_{yj}}{k_{cy}} \right) \text{ mm}$$

δ_{yi} is to be calculated for each end wall of the container, taking into account lashing devices attached to the top corner of container i and the bottom corner of container $(i + 1)$

where

RA_{yi} = transverse racking force in end wall of container i , taking into account lashing rods and other lashing devices attached to the top corner of container i and above attached to the end wall being considered, see also Table 14.9.4 Total resulting forces in each end/side wall of an unlashed stack

$$= \sum_{j=1}^N F_j + \sum_{r=1}^R TL_{yr} \text{ kN}$$

k_{cy} = shear spring stiffness of the end wall being considered, see Table 14.9.2 Shear spring stiffness of container walls

TL_{yr} = force in lashing device r , measured in the transverse direction, see Pt 3, Ch 14, 9.5 Forces in the lashing devices.

9.4.9 The longitudinal displacements of the container stack are to be calculated as follows. The displacement of the top corner of container i under the actions of the applied forces and supporting lashing devices is given by:

$$\delta_{xi} = \sum_{j=1}^i \left(\frac{RA_{xj}}{k_{cx}} \right) \text{ mm}$$

δ_{xi} is to be calculated for each side wall of the container, taking into account lashing devices attached to the top corner of container i and the bottom corner of container $(i + 1)$.

9.4.10 The final distribution of forces in the stack is to be obtained by equating the total transverse displacements of the container stack δ_{yi} due to the applied loads with the transverse elongations in the attached lashing devices ϵ_{LyT} . This is illustrated in Figure 14.9.2 Example of lashings at one end of a four-tier stack. Hence, at each lashing device, the following equation is to be satisfied:

$$\delta_{yi} = \epsilon_{LyT} \text{ mm}$$

where

ϵ_{LyT} = elongation or strain in the transverse direction in the lashing device, in mm.

9.4.11 The equations for deriving the total forces in the stack with lashings are given in Table 14.9.4 Total resulting forces in each end/side wall of an unlashed stack. The final distribution of forces in a stack can also be solved using matrix methods.

Table 14.9.4 Total resulting forces in each end/side wall of an unlashed stack

Force	Equations for lashed stack
(a) Racking force in end/side wall of container i Taking into account lashing rods and other lashing devices attached to the top corner of container i and above	
Transverse	$RA_{yi} = \sum_{j=i}^N F_j + \sum_{r=i}^R TL_{yr} \text{ kN}$ <p>To be evaluated for each end wall of the container taking into account lashing devices attached to the wall being considered</p>

<p>Longitudinal</p>	$RA_{xi} = \sum_{j=i}^N G_j + \sum_{r=i}^R TL_{xr} \text{ kN}$ <p>To be evaluated for each side wall of the container taking into account lashing devices attached to the wall being considered</p>
<p>(b) Compressive force in each corner post of container <i>i</i> Taking into account lashing rods and other lashing devices attached to the top corner of container <i>i</i> and above. The lashing device forces appropriate to the wall and corner are to be taken into account</p>	
<p>Transverse</p>	$SF_{yi} = 0,55 \sum_{j=i}^N (H_j + Q_j) + 0,55 \sum_{r=i}^R TL_{yr} \text{ kN}$ <p>To be evaluated for each end wall of the container, taking into account lashing devices attached to the wall being considered</p>
<p>Longitudinal</p>	$SF_{xi} = 0,55 \sum_{j=i}^N (J_j) + 0,55 \sum_{r=i}^R TL_{xr} \text{ kN}$ <p>To be evaluated for each side wall of the container, taking into account lashing devices attached to the wall being considered</p>
<p>Total shear force</p>	$SF_i = \sqrt{SF_{xi}^2 + SF_{yi}^2} \text{ kN}$ <p>To be evaluated for each corner</p>
<p>(c) Compressive force in each corner post of container <i>i</i> Taking into account lashing rods and other lashing devices attached to the top corner of container <i>i</i> and above. The lashing device forces appropriate to the wall and corner are to be taken into account</p>	
<p>Port fwd</p>	$V_{pfi} = \sum_{j=i}^N P_j + \frac{1}{a} \sum_{j=i}^N F_j h_{ij} + \frac{1}{b} \sum_{j=i}^N G_j h_{ij} + \sum_{r=1}^R TL_r \sin \theta_{Lr} + \frac{1}{a} \sum_{r=1}^R TL_{yr} h_{ir} + \frac{1}{b} \sum_{r=1}^R TL_{xr} h_{ir} \text{ kN}$
<p>Port aft</p>	$V_{pai} = \sum_{j=i}^N P_j + \frac{1}{a} \sum_{j=i}^N F_j h_{ij} - \frac{1}{b} \sum_{j=i}^N G_j h_{ij} + \sum_{r=1}^R TL_r \sin \theta_{Lr} + \frac{1}{a} \sum_{r=1}^R TL_{yr} h_{ir} - \frac{1}{b} \sum_{r=1}^R TL_{xr} h_{ir} \text{ kN}$
<p>Starboard fwd</p>	$V_{sfi} = \sum_{j=i}^N P_j - \frac{1}{a} \sum_{j=i}^N F_j h_{ij} + \frac{1}{b} \sum_{j=i}^N G_j h_{ij} + \sum_{r=1}^R TL_r \sin \theta_{Lr} - \frac{1}{a} \sum_{r=1}^R TL_{yr} h_{ir} + \frac{1}{b} \sum_{r=1}^R TL_{xr} h_{ir} \text{ kN}$
<p>Starboard aft</p>	$V_{sai} = \sum_{j=i}^N P_j - \frac{1}{a} \sum_{j=i}^N F_j h_{ij} - \frac{1}{b} \sum_{j=i}^N G_j h_{ij} + \sum_{r=1}^R TL_r \sin \theta_{Lr} - \frac{1}{a} \sum_{r=1}^R TL_{yr} h_{ir} - \frac{1}{b} \sum_{r=1}^R TL_{xr} h_{ir} \text{ kN}$
<p>(d) Compressive/lifting force at the bottom fitting of each corner post of container <i>i</i> Taking into account lashing rods and other lashing devices attached to the bottom corner of container <i>i</i> and above. The lashing device forces appropriate to the wall and corner are to be taken into account. The equations for the 'Compressive force in each corner post' are applied except that the lashing rods attached to the bottom of the container are included. This only affects the $\sum_{r=1}^R TL_r \sin \theta_{Lr}$ term</p>	
<p style="text-align: center;">Symbols</p>	
<p><i>h_{ir}</i> is the height from the bottom of the lower corner device of container <i>i</i> to lashing point <i>r</i>, in metres <i>R</i> is the total number of lashing devices <i>Q_j</i> is only applied to the exposed container faces</p>	

9.4.12 Similar calculations are to be applied in the longitudinal direction if any lashing device will resist longitudinal forces. For such lashings, the fixed lashing plates are to be suitably arranged to accommodate the additional forces due to the fore and aft inclination of the lashing rods. In addition, the design of the lashing rod head should be suitable for the angle of inclination of the lashing rod.

9.4.13 The above stiffness model assumes that the securing devices between tiers of containers are capable of resisting negative (separation) forces. That is, where separation forces are found, suitable locking devices are assumed to be fitted and transmitting load. When this is not the case, special consideration of the vertical displacements of the corners and forces in the lashing devices is necessary.

9.5 Forces in the lashing devices

9.5.1 The tensile or compressive force in a lashing device is given by:

$$TL_r = \varepsilon_{Lr} k_{Lr} \text{ kN}$$

The lashing device force in the positive transverse direction (i.e. positive to port) is given by:

$$TL_{yr} = \varepsilon_{Lr} k_{Lr} \cos \theta_{Lr} \sin \theta_{Lxyr} \text{ kN}$$

The lashing device force in the positive longitudinal direction (i.e. positive forwards) is given by:

$$TL_{xr} = \varepsilon_{Lr} k_{Lr} \cos \theta_{Lr} \cos \theta_{Lxyr} \text{ kN}$$

where

k_{Lr} = stiffness of lashing rod or device r , in kN/mm, see Pt 3, Ch 14, 9.4 Total resulting forces in a stack incorporating lashings 9.4.1.

9.5.2 The stiffness of a lashing rod may be derived as follows:

$$k_{Lr} = \frac{E_r A_r}{l_r}$$

= if E_r and A_r are specified otherwise k_{Lr} may be directly specified

E_r = effective modulus of elasticity, see Table 14.9.3 Effective modulus of elasticity of lashing devices

A_r = cross-sectional area of lashing device

For a para-lash arrangement, where two lashing devices are modelled as a single device, the effective area is to be taken as 1,5 times the area of one device. If each device in a paralash arrangement is modelled, the effective area for each device is to be taken as 0,75 times the area of the single device.

ε_{Lr} = total elongation, in mm, of lashing rod or device r

$$\varepsilon_{Lr} = \sqrt{(l_x - \delta_{xib})^2 + (l_y - \delta_{yib})^2 + (l_z - \delta_{zib})^2} - l_r$$

ε_{Lr} = for a lashing rod device

ε_{Lr} = 0 for a shore device (compression-only device), see Pt 3, Ch 14, 6.1 General 6.1.7

ε_{Lr} = can be negative or positive for a buttress lashing connection or tension/compression lashing device, see Pt 3, Ch 14, 6.1 General 6.1.6

i_b = $i-1$ if lashing device is connected to the bottom of the container

i_b = i if lashing device is connected to the top of the container

l_x = longitudinal distance of lashing foundation from container corner fitting, in mm, positive forward

l_y = transverse distance of lashing foundation from container corner fitting, in mm, positive to port

l_z = vertical separation of lashing foundation from container corner fitting, in mm, positive downwards

l_r = length of lashing rod or device, in mm

$$= \sqrt{(l_x)^2 + (l_y)^2 + (l_z)^2} \omega$$

δ_{xi} = total longitudinal racking deflection of the top corner of container i , in mm

δ_{yi} = total transverse racking deflection of the corner of container i , in mm

δ_{zi} = total vertical displacement of the bottom corner of container i , in mm

θ_{Lr} = angle of the lashing rod r in the vertical plane

$$\theta_{Lr} = \tan^{-1} \left(\frac{l_z}{\sqrt{l_x^2 + l_y^2}} \right) \text{ degrees}$$

NOTE

θ_{Lr} = is 90° when l_x and l_y are both zero

θ_{Lxyr} = angle of the lashing rod r in the xy plane (projection onto the horizontal plane)

$$= \tan^{-1} \left(\frac{l_y}{l_x} \right) \text{ degrees}$$

Use the atan2 function to maintain sign of angle. θ_{Lxyr} is 0° when l_x is positive and l_y is zero, θ_{Lxyr} is +90° when l_x is 0 and l_y is positive, θ_{Lxyr} is -90° when l_x is 0 and l_y is negative.

9.5.3 Where external support is provided by a buttress or shore, the load is to be transmitted between adjacent stacks by linkages in line with the support. The force in the transverse end wall members of the containers adjacent to the support is given by:

$$F_b \left(\frac{2N-1}{2N} \right) \text{ kN and the force in the linkage to the adjacent container is } F_b \left(\frac{N-1}{N} \right) \text{ kN}$$

where

F_b = calculated force in the buttress or shore, in kN

N = number of rows of containers supported by the buttress or shore.

9.6 Allowable forces on containers

9.6.1 For ISO containers, the securing arrangements are to be designed so that the forces on the containers do not exceed the values shown in *Table 14.9.5 Allowable forces on ISO containers*. The maximum forces for ISO 1496-1: 1990 including Amendment Nos. 1, 2 and 3 containers are illustrated in *Figure 14.9.3 Allowable forces for 20 ft or 40 ft containers constructed to ISO 1496-1:1990 including Amendment Nos. 1, 2 and 3*. Proposals to carry out the lashing calculations for containers manufactured in accordance with ISO 1496-1:1990/Amendment No. 4, 2006 will be specially considered.

Table 14.9.5 Allowable forces on ISO containers

	ISO 1496-1:1990 including up to Amendment No. 3	
	20ft	40ft
	in kN	
Horizontal force from a container fitting acting parallel to the side face	150	150
Horizontal force from lashing on container fitting acting parallel to the end face, see Note 1	225	225
Vertical force from lashing on container fitting acting parallel to the end or side face, see Note 1	250	250
Racking force on container end	150	150
Racking force on container side	150	150
Vertical forces at each top corner, tension	250	250
Vertical forces at each bottom corner, tension	250	250
Vertical forces at each top corner post, compression	848	848
Vertical forces at each bottom corner casting of the lowest container in a stack, compression	848 + (1,8Rg/4) see Note 3	848 + (1,8Rg/4) see Note 3
Transverse forces acting at the level of and parallel to the top face, tension or compression, see Note 2	340	340
Transverse forces acting at the level of and parallel to the bottom face, tension or compression, see Note 2	500	500
<p>Note 1. In no case is the resultant of the horizontal and the vertical forces to exceed the limiting values derived from <i>Figure 14.9.3 Allowable forces for 20 ft or 40 ft containers constructed to ISO 1496-1:1990 including Amendment Nos. 1, 2 and 3.</i> The horizontal and vertical forces are the maximum components of a diagonal force and are not to be used as the maximum load if horizontal or vertical lashings are employed.</p> <p>Note 2. Where a buttress supports the stack at an intermediate level, the total transverse force in the containers at the level is not to exceed the sum of the appropriate top and bottom forces.</p> <p>Note 3. The vertical compression force on the lower corner casting on the closed end of the lowest container may exceed 848 + (1,8Rg/4) kN, provided the following conditions are complied with:</p> <p>(a) The vertical compression force acting on the lowest container from the container above does not exceed 848 kN.</p> <p>(b) The horizontal racking force acting on the lowest container from the container above does not exceed 150 kN.</p> <p>(c) The local ship side or hatch cover container foundation is designed and approved for the increased design compression force.</p> <p>(d) The loose bottom container securing fittings should have a contact area fulfilling the requirements of <i>Pt 3, Ch 14, 3.2 Materials and design 3.2.5.</i></p>		

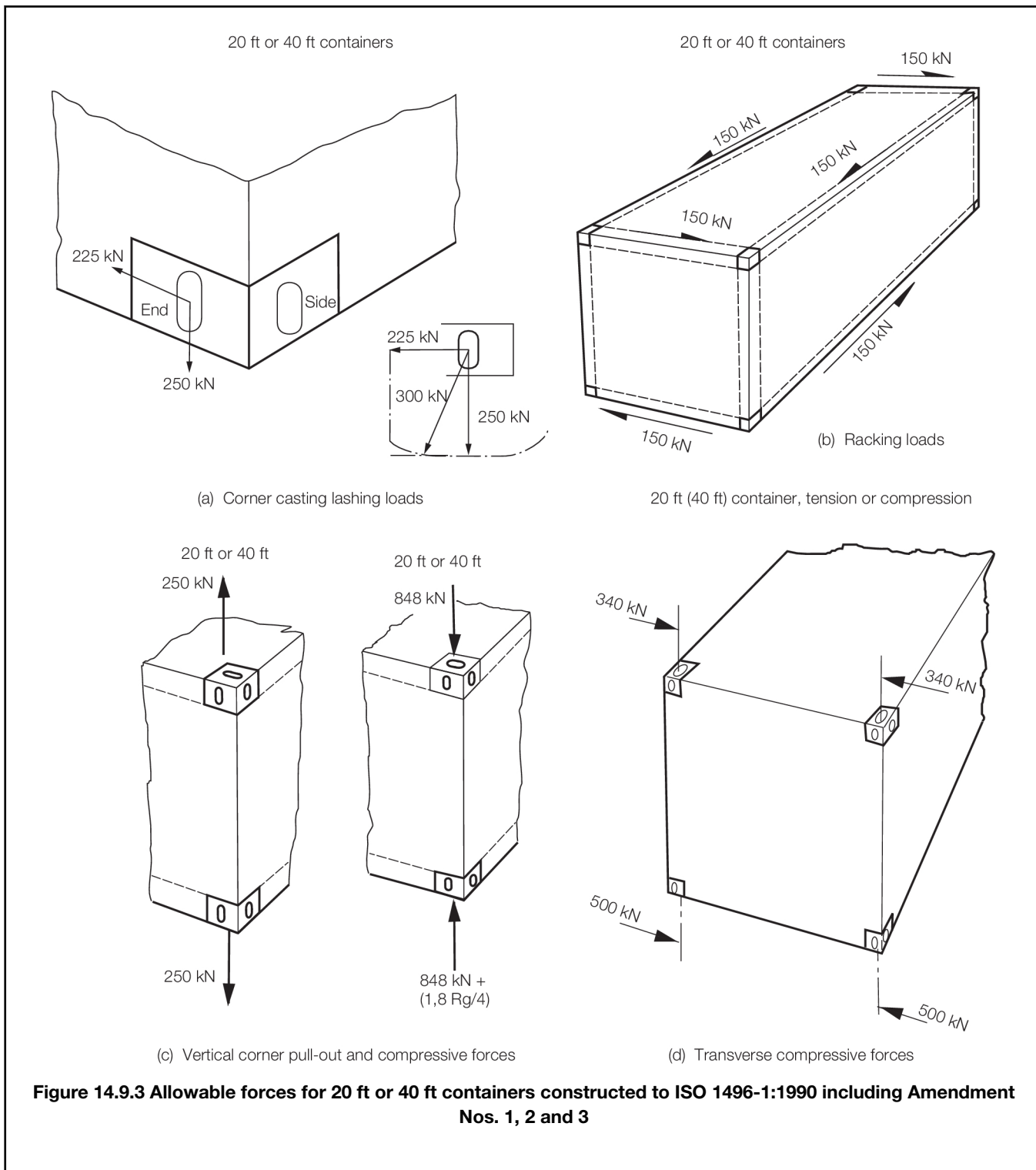

9.6.3 The allowable forces for containers of other dimensions, e.g. 24 ft, 48 ft and 53 ft, will be determined on the basis of the values in *Table 14.9.5 Allowable forces on ISO containers* and of the forces for which the container has been certified.

9.6.4 Where 45 ft containers in accordance with ISO 1496-1:1990/Amendment No. 4, 2006 are stowed on top of a 40 ft container, the corner post load of the top castings of the 45 ft container is not to exceed a compression force of 404 kN. Consideration should be given to the strength of the container bottom structure to withstand the forces transmitted. No lashings are to be applied to the ends of the 45 ft container if stowed on top of a 40 ft unit.

■ *Section 10*
Surveys

10.1 Initial Survey

10.1.1 The following requirements are mandatory for fixed fittings, including cell guides, if fitted, on all ships. For ships having a **CCSA** class notation the requirements are also applicable for loose fittings.

10.1.2 The Surveyor is to be satisfied that the materials, workmanship and arrangements are satisfactory and in accordance with the requirements and the approved plans. Any items found not to be in accordance with the requirements or the approved plans, or any material, workmanship or arrangements found to be unsatisfactory are to be rectified.

10.1.3 A Register or plan is to be kept on board and up to date, and is to be made available to the Surveyor upon request. The Register or plan is to contain sufficient details to enable all fittings to be identified, including:

- a simple sketch;
- the name of the item;
- the number supplied;
- the manufacturer's mark or code; and
- the safe working load with the corresponding breaking load.

10.1.4 For container securing arrangements, a suitable Container Stowage Arrangement Plan is to accompany the Register. Where containers of types other than ISO containers are proposed to be carried, their stowage locations are to be clearly indicated on the plan.

10.1.5 The Register and stowage plans, if applicable, may be included in the Cargo Securing Manual.

10.2 Periodical Surveys

10.2.1 For the requirements for Periodical Surveys, see *Pt 1, Ch 3, 2.2 Annual Surveys* and *Pt 1, Ch 3, 5.3 Examination and testing*.

Quality Assurance Scheme for the Hull Construction of Ships

Part 3, Chapter 15

Section 1

Section

- 1 **General**
- 2 **Application**
- 3 **Particulars to be submitted**
- 4 **Requirements of Parts 1 and 2 of the Scheme**
- 5 **Additional requirements for Part 2 of the Scheme**
- 6 **Initial assessment of the shipyard**
- 7 **Approval of the shipyard**
- 8 **Maintenance of approval**
- 9 **Suspension or withdrawal of approval**

■ Section 1 General

1.1 Definitions

1.1.1 **Quality Assurance Scheme.** Lloyd's Register's (hereinafter referred to as 'LR') Quality Assurance requirements for the hull construction of ships are defined as follows:

- **Quality Assurance.** All activities and functions concerned with the attainment of quality including documentary evidence to confirm that such attainment is met.
- **Quality system.** The organisation structure, responsibilities, activities, resources and events laid down by Management that together provide organised procedures (from which data and other records are generated) and methods of implementation to ensure the capability of the shipyard to meet quality requirements.
- **Quality programme.** A documented set of activities, resources and events serving to implement the quality system of an organisation.
- **Quality plan.** A document derived from the quality programme setting out the specific quality practices, special processes, resources and activities relevant to a particular ship or series of sister ships. This document will also indicate the stages at which, as a minimum, direct survey and/or system monitoring will be carried out by the Classification Surveyor.
- **Quality control.** The operational techniques and activities used to measure and regulate the quality of hull construction to the required level.
- **Inspection.** The process of measuring, examining, testing, gauging or otherwise comparing the item with the approved drawings and the shipyard's written standards including those which have been agreed by LR for the purposes of classification of the specific ship type concerned.
- **Assessment.** The initial comprehensive review of the shipyard's quality systems, prior to the granting of approval, to establish that all the requirements of these Rules have been met.
- **Audit.** A documented activity aimed at verifying by examination and evaluation that the applicable elements of the quality programme continue to be effectively implemented.
- **Hold point.** A defined stage of manufacture beyond which the work must not proceed until the inspection has been carried out by all the relevant personnel.
- **System monitoring.** The act of checking, on a regular basis, the applicable processes, activities and associated documentation that the Shipbuilder's quality system continues to operate as defined in the quality programme.
- **Special process.** A process where some aspects of the required quality cannot be assured by subsequent inspection of the processed material alone. Manufacturing special processes include welding, forming and the application of protective treatments. Inspection and testing processes classified as special processes include non-destructive examination and pressure and leak testing.

Quality Assurance Scheme for the Hull Construction of Ships

Part 3, Chapter 15

Section 2

1.2 Scope of the Quality Assurance Scheme

1.2.1 This Chapter specifies the minimum Quality System requirements for a shipyard to construct ships under LR's Quality Assurance Scheme.

1.2.2 For the purposes of this Chapter of the Rules, hull construction comprises the hull structure; containment systems, including those which are independent of the main hull structure; appendages; superstructures; deckhouses; and closing appliances all as required by the Rules.

1.2.3 Although the requirements of this Scheme are, in general, for steel ships of all welded construction, other materials for use in hull construction will be considered.

■ Section 2 Application

2.1 Certification of the shipyard

2.1.1 LR will give consideration to a shipyard's Quality Assurance System provided, at all times, there is full commitment by all the shipyard personnel to the implementation and maintenance of this system. On satisfactory completion of assessments and audits LR will issue certificates of approval to the shipyard as indicated in *Pt 3, Ch 15, 2.1 Certification of the shipyard 2.1.2*.

2.1.2 LR's Quality Assurance Scheme comprises:

- Part 1 The requirements of the Quality System for hull construction which are applicable to shipyards operating a quality programme but not necessarily constructing to LR's Class. Certificates of approval valid for three years will be issued, with intermediate audits at intervals of 6 months.
- Part 2 The Quality System requirements for hull construction for application to ships under construction to LR's Class as part of the Special Survey. LR's particular requirements for construction of ships to its Class, and the continuous involvement in the hull construction process by a combination of direct survey and systems monitoring by LR's Surveyors, are provided for by Part 2. Where LR considers that there is a stage in construction at which a high degree of direct inspection by the Surveyors is desirable, this stage will be described on the Part 2 Approval Certificate.

Certificates of approval for Part 2 will be valid for one year, and will be issued after satisfactory assessment/audit carried out at a suitable stage during construction to LR's Class. Part 1 certification will automatically be issued, or re-issued as applicable, on attainment of Part 2 approval.

2.1.3 Chemical carriers with cargo tank structure of material other than carbon manganese steel and the cargo containment system on ships for liquefied gases will be specially considered. The procedure relating to the construction of such structure on chemical carriers and liquefied gas containment systems is to be separately prescribed in the Quality Plan which will be subject to approval by LR.

2.1.4 The Quality System at a shipyard will be examined for compliance with these Rules by the assessments and audits as laid down in *Pt 3, Ch 15, 4 Requirements of Parts 1 and 2 of the Scheme, Pt 3, Ch 15, 5 Additional requirements for Part 2 of the Scheme and Pt 3, Ch 15, 6 Initial assessment of the shipyard*. Initial and periodical approval of the system will be considered by the Committee on receipt of satisfactory assessment and audit reports.

2.1.5 All information and data submitted by a Shipbuilder for approval under this Scheme and for maintenance of approval will be treated by LR in strict confidence and will not be disclosed to any third party without the prior written consent of the Shipbuilder.

2.1.6 A list of shipyards approved under the Scheme will be held in the *List of Shipyards Approved to the Requirements of the Quality Assurance Scheme*.

Quality Assurance Scheme for the Hull Construction of Ships

Part 3, Chapter 15 Section 3

■ Section 3

Particulars to be submitted

3.1 Documentation and procedures

3.1.1 Under either Part of the Scheme, the documentation to meet the requirements of *Pt 3, Ch 15, 4 Requirements of Parts 1 and 2 of the Scheme* is to be submitted. This documentation includes the Quality Manual, Quality Plans, documented procedures and work instructions.

3.1.2 Additionally, under Part 2 of the Scheme the documentation to meet the requirements of *Pt 3, Ch 15, 5 Additional requirements for Part 2 of the Scheme* is to be submitted for approval. Construction plans and all necessary particulars are also to be submitted for approval in accordance with the relevant requirements of the Rules. See *Pt 1, Ch 2, 3.2 New construction surveys 3.2.1*.

3.2 Amendments

3.2.1 Any major changes to the documentation or procedures required by *Pt 3, Ch 15, 4 Requirements of Parts 1 and 2 of the Scheme* or *Pt 3, Ch 15, 5 Additional requirements for Part 2 of the Scheme* are to be re-submitted.

■ Section 4

Requirements of Parts 1 and 2 of the Scheme

4.1 General

4.1.1 The requirements of this Section are applicable to shipyards seeking approval under Parts 1 and 2 of the Scheme.

4.2 Policy statement

4.2.1 A policy statement, signed by the chief executive of the shipyard concerned, confirming the full commitment of all levels of personnel in the shipyard to the implementation and sustained operation of quality assurance methods is to be included in the Quality Manual.

4.3 Responsibility

4.3.1 Personnel responsible for functions affecting quality are to have defined responsibility and authority to identify, control and evaluate quality.

4.4 Management Representative

4.4.1 The Shipbuilder is to appoint a Management Representative, who is to be independent of other functions unless specifically agreed otherwise by LR, and who is to have the necessary authority and responsibility for ensuring that the requirements of the Scheme are complied with.

4.4.2 The Management Representative is to have the authority to stop production if serious quality problems arise.

4.5 Quality control and testing personnel

4.5.1 The Shipbuilder is to utilise quality control and testing personnel whose performance and continued freedom of influence from production pressures is to be systematically confirmed by the Management Representative.

4.6 Resources

4.6.1 Sufficient resources shall be provided by the shipyard to enable the requirements identified by the Quality Management System to be effectively implemented.

Quality Assurance Scheme for the Hull Construction of Ships

Part 3, Chapter 15

Section 4

4.7 The Quality Management System

4.7.1 The Shipbuilder is to establish, document and maintain an effective Quality Management System that will ensure and demonstrate that materials and consumables used, and working processes employed, conform to the requirements for hull construction.

4.7.2 **Quality Manual.** The basic documentation is to be in the form of a Quality Manual which sets out the general quality policies and which references the detailed procedures, standards, etc. and includes the requirements of *Pt 3, Ch 15, 4.2 Policy statement to Pt 3, Ch 15, 4.24 Sub-contracted personnel, services and components* and, where appropriate, *Pt 3, Ch 15, 5.1 Quality System procedures to Pt 3, Ch 15, 5.10 Sub-contracted personnel, services and components*.

4.7.3 **Procedures.** The Shipbuilder is to establish, document and maintain an adequate and defined control of the hull construction process comprising:

- (a) defined and documented controls, processes, procedures, tolerances, acceptance/rejection criteria and workmanship standards; and
- (b) the provision of Quality Plans for each ship or series of sister ships for the processes and procedures for manufacture, inspection and testing involved from receipt of material through to completion of the hull construction process.

4.7.4 **Work instructions.** The Shipbuilder is to develop and maintain clear and complete documented work instructions for the processes and standards involved in the construction of the hull. Such instructions are to provide directions to various levels of personnel.

4.8 Regulatory requirements

4.8.1 The Shipbuilder is to establish that the requirements of all applicable Regulations are clearly specified and agreed with the Owner/Classification Society/Regulatory Authority. These Regulations are to be made available for all functions that require them and their suitability is to be reviewed.

4.8.2 The Shipbuilder is to establish a design verification procedure to ensure that the regulatory requirements have been incorporated into the design output.

4.9 Control of hull drawings

4.9.1 The Shipbuilder is to establish, document and maintain a procedure for the submission to the Classification Society and other regulatory bodies of all the necessary drawings required for approval sufficiently early and in such a manner that the requirements of the Classification Society and other regulatory bodies can be included in the design before construction commences. This procedure is to include a provision which ensures that all amendments to approved drawings are incorporated in the working drawings and that design revisions are re-submitted for approval.

4.10 Documentation and change control

4.10.1 The Shipbuilder is to establish a procedure to ensure that:

- (a) valid drawings, specifications, procedures, work instructions and other documentation necessary for each phase of the fabrication process are prepared;
- (b) all necessary documents and data are made readily available at all appropriate work, testing and inspection locations;
- (c) all amended drawings and changes to documentation are processed in a timely manner to ensure inclusion in the production process;
- (d) records are maintained of amendments and changes to documentation; and
- (e) provision is made for the prompt removal or immediate identification of all superseded drawings and documentation throughout the shipyard.

4.11 Purchasing data and receipt

4.11.1 The Shipbuilder is to maintain purchasing documents containing a clear description of the materials ordered for use in hull construction and the standards to which material must conform, and the identification and certification requirements.

4.11.2 For the requirements for receiving inspection of purchased items see *Pt 3, Ch 15, 4.15 Control of inspection and testing*.

4.12 Owner supplied material

4.12.1 The Shipbuilder is to have procedures for the inspection, storage and maintenance of Owner supplied materials and equipment.

4.13 Identification and traceability

4.13.1 The Shipbuilder is to establish and maintain a procedure to ensure that materials and consumables used in the hull construction process are identified (by colour-coding and/or marking as appropriate) from arrival at the shipyard through to erection in such a way as to enable the type and grade to be readily recognised. The procedure is to ensure that the Shipbuilder has the ability to identify material in the completed vessel and ensure traceability to the mill sheets.

4.14 Fabrication control

4.14.1 The Shipbuilder is to establish, document and maintain suitable procedures to ensure that fabrication and construction operations are carried out under controlled conditions. Controlled conditions are to include:

- (a) clearly documented work instructions defining material treatment, marking, cutting, forming, sub-assembly, assembly, erection, fitting of closing appliances, use of fabrication aids and associated fit-up, weld preparation, welding and dimensional control procedures;
- (b) criteria for workmanship and manufacturing tolerances. These are to be documented in a clear manner and made available to the appropriate workforce, and are to include acceptance/rejection criteria; and
- (c) documented instructions for the control of equipment and machines used in fabrication. These are to be made available to the appropriate workforce and supplied to individuals where necessary.

4.14.2 The Shipbuilder is to establish and control welding, non-destructive examination and painting which are part of the fabrication system, the equipment used in such processes and the environment in which they are employed. Operators of these special processes are to be properly qualified. Details of these processes are to be included in the relevant Quality Plans.

4.14.3 A list of approved welding procedures is to be maintained and made available to relevant personnel. Records of the results of testing for approval are also to be maintained. Lists of appropriately qualified welders are to be maintained. Procedures for distribution and recycling of welding consumables are to be implemented.

4.14.4 The Shipbuilder is to establish, document and maintain adequate maintenance schedules and standards for all equipment associated with the hull construction process.

4.15 Control of inspection and testing

4.15.1 The Shipbuilder is to be responsible for ensuring that all incoming plates, sections, castings, components, fabrications and consumables and other materials used in the hull construction process are inspected or otherwise verified as conforming to purchase order requirements.

4.15.2 The Shipbuilder is to provide an inspection system at suitable stages of the fabrication process from the material delivery to the completion of hull construction. The inspection system is to confirm and record the inspections carried out.

4.16 Indication of inspection status

4.16.1 The Shipbuilder is to establish and maintain a system for identifying the inspection status of structural components at appropriate stages of the fabrication process. This may include the direct marking of components. Records of inspection and measurements are to be identifiable to components to which they refer and be readily accessible to production and inspection personnel and to Classification Surveyors.

4.17 Inspection, measuring and test equipment

4.17.1 The Shipbuilder is to be responsible for the control, calibration, and maintenance of the inspection, measuring and test equipment used in the fabrication and non-destructive examination of the hull structure.

4.17.2 The calibration system is to allow traceability back to appropriate National Standards. Where these do not exist the basis of calibration is to be defined.

4.18 Non-conforming materials and corrective action

4.18.1 The Shipbuilder is to establish and define procedures to provide for:

-
- (a) the clear identification and segregation from production areas of all plates, sections, castings, components, fabrications, consumables and other materials which do not conform to the agreed specification; and
- (b) the initiation of authorised corrective or alternative action.

4.19 Protection and preservation of quality

4.19.1 The Shipbuilder is to establish and maintain a procedure to control handling and preservation processes for both the material used in fabrication and the structural components at all stages of the fabrication process. This procedure is to ensure conformance to specified requirements and established standards.

4.19.2 Welding consumables are to be stored, handled and recycled according to maker's recommendations.

4.20 Records

4.20.1 The Shipbuilder is to develop and maintain records that demonstrate achievement of the required quality and the effective operation of the Quality System. Records demonstrating sub-contractor achievement of these requirements are to be maintained. These records are to be retained and available for a defined period. These records are to include identification of materials and consumables used in fabrication, the number and class of defects found during fabrication and information regarding corrective action taken. Records of particular processes, e.g. plate surface preparation and priming, marking, cutting, forming, accuracy control, non-destructive examination, audits and all other records pertaining to the operation of the Quality System are also to be maintained.

4.21 Internal audit and management review

4.21.1 Internal audits of the performance of all aspects of the systems relating to design, production and testing are to be carried out systematically by appointed staff and recorded under the authority of the Management Representative. These staff members will not normally audit functions for which they are directly responsible.

4.21.2 Using data obtained from the audits and any other available relevant information, management reviews are to take place at specified intervals or more frequently as deemed necessary in order to review the performance of the Quality System.

4.21.3 The Shipbuilder is to establish, document and maintain a procedure for corrective application of data feedback from previous construction, including previous ships during the guarantee period.

4.21.4 The Shipbuilder is to establish, document and maintain a procedure to provide for the analysis of departures from manufacturing standards, steel material scrapped, reworked or repaired during the fabrication and construction process in order to detect trends, investigate the cause to determine the action needed to correct the processes and work procedures, or to identify the further training of operators as appropriate.

4.21.5 Agreed improvements to the Quality System are to be implemented within a time scale appropriate to the nature of the improvement.

4.22 Training

4.22.1 The Shipbuilder is to establish and maintain a system to identify training needs and ensure that all personnel involved in the fabrication, erection and quality-involved functions have adequate experience, training and qualifications. This requirement extends to sub-contractor personnel working within the shipyard. Records are to be available to the Classification Surveyor.

4.23 Sampling

4.23.1 Any sampling processes used by the Shipbuilder are to be in accordance with specified or Statutory Requirements or to the satisfaction of the Classification Surveyor as applicable.

4.24 Sub-contracted personnel, services and components

4.24.1 The requirements of the Scheme are applicable, as appropriate, to all sub-contractor personnel and sub-contracted services operating within the shipyard.

4.24.2 The requirements of the Scheme are not applicable to sub-contractor personnel or sub-contracted services operating at locations outside the shipyard. In these circumstances it will be necessary for inspections to be carried out by the LR Surveyor using conventional survey methods.

■ Section 5

Additional requirements for Part 2 of the Scheme

5.1 Quality System procedures

5.1.1 The procedures detailed in *Pt 3, Ch 15, 4.7 The Quality Management System* are to be submitted for approval.

5.2 Quality Plans

5.2.1 Quality Plans for ships which are to be classed by LR are to be submitted for approval well in advance of commencement of work, irrespective of any submissions that may have been made for sister ships under Part 1 of the Scheme. Such Quality Plans are to outline all of the manufacturing, testing and inspection operations to be performed by the Shipbuilder and by which personnel they will be carried out. The Quality Plans are then to be submitted to the LR Surveyors who will indicate all the stages at which they will perform system monitoring, carry out direct inspection and participate in hold point inspections. These hold points will include, but not be limited to, the following:

- (a) Radiographs and other test records of non-destructive examinations as required for Classification purposes, see *Ch 13, 2.12 Non-destructive examination of welds* of the Rules for Materials.
- (b) The items described in *Pt 3, Ch 1, 8 Inspection and workmanship* relevant to the scope of this Chapter.

5.2.2 Notwithstanding what may have been agreed in the Quality Plans, the LR Surveyors have the discretion to increase their involvement, see also *Pt 3, Ch 15, 8.1 General 8.1.5*.

5.3 Material supplier approval

5.3.1 The Shipbuilder is to ensure that hull construction materials and consumables used are selected from manufacturers who are approved by LR.

5.4 Identification and traceability

5.4.1 The procedure required by *Pt 3, Ch 15, 4.13 Identification and traceability 4.13.1* is to be submitted for approval.

5.5 Fabrication control

5.5.1 The information required by *Pt 3, Ch 15, 4.14 Fabrication control 4.14.1* will be examined for acceptability.

5.5.2 Procedures for material treatment, forming, weld preparation and welding are to be submitted for approval.

5.5.3 Procedures required by *Pt 3, Ch 15, 4.14 Fabrication control 4.14.3* are to be submitted to the LR Surveyors for approval.

5.6 Control of inspection and testing

5.6.1 The inspection stages incorporated into the Scheme are to include specific checks for fit-up and welding which are to be carried out at each sub-assembly, assembly, pre-erection and erection stage as well as self-checking by the operator. The number of recorded checks to each stage will be agreed with the LR Surveyor, after consideration of documentary evidence of quality being achieved. Repairs, where required, are to be effected after each check. Collated Quality Control data to demonstrate the efficiency of the above self-check system are to be made available to the LR Surveyor by the Shipbuilder. The Quality Plans referred to in *Pt 3, Ch 15, 4.7 The Quality Management System 4.7.3* provide the opportunity for the Shipbuilder and the LR Surveyor to consider the structural design and ship type fully in order to determine the most efficient and effective inspection stages.

5.7 Control of non-conforming materials and corrective action

5.7.1 All predetermined repair procedures are to be consistent with the requirements of *Pt 3, Ch 15, 4.7 The Quality Management System 4.7.3* and are to be to the satisfaction of the LR Surveyor. Where a defect is found, whether by the LR Surveyor or through shipyard inspection, for which no agreed repair procedure exists, approval is to be obtained from the LR Surveyor before any corrective action is effected.

5.8 Records

5.8.1 The shipyard is to make data available to the LR Surveyor, to demonstrate the efficiency of the inspection system, see *Pt 3, Ch 15, 5.6 Control of inspection and testing 5.6.1*.

5.9 Training

5.9.1 The competence of the welding operators, non-destructive examination and other personnel involved in special processes and inspection are to be to the satisfaction of the LR Surveyor.

5.10 Sub-contracted personnel, services and components

5.10.1 The requirements of the Scheme are not applicable to those services operating at locations outside the shipyard. It will be necessary for inspections to be carried out by the LR Surveyor using conventional survey methods.

5.10.2 The methods of control for the requirements of *Pt 3, Ch 15, 4.24 Sub-contracted personnel, services and components 4.24.1* are to be submitted to the LR Surveyor.

■ Section 6
Initial assessment of the shipyard**6.1 General**

6.1.1 In the first instance applications for approval under this Scheme will be considered on the recommendation of the local Surveyors.

6.1.2 After receipt and appraisal of the main quality documentation, an assessment of the shipyard is to be carried out by the Surveyors to examine all aspects of the Quality System applicable to hull construction.

6.1.3 The Surveyors will review the quality arrangements proposed by the Shipbuilder at the shipyard. They may advise as to how the proposed Quality System might be improved and where it is considered inadequate, advise how it might be revised to be acceptable to LR.

6.1.4 For assessment to Part 1 of the Scheme, the Surveyors will review the Quality System in association with the quality documentation and will check that all aspects of the System are established and in accordance with the requirements of *Pt 3, Ch 15, 3 Particulars to be submitted*.

6.1.5 For assessment of Part 2 of the Scheme, the Surveyors will confirm that the requirements given in *Pt 3, Ch 15, 3 Particulars to be submitted* have been fully implemented and are complied with by a detailed examination of work in progress and by confirming that workmanship and the quality level being consistently achieved are to their satisfaction.

■ Section 7
Approval of the shipyard**7.1 General**

7.1.1 If the initial assessment confirms that the shipyard's quality arrangements are satisfactory, the Committee will issue Part 1 or Part 2 and Part 1 of LR's Quality Assurance Approval Certificates as appropriate. Maintenance of approval will be subject to the provisions of *Pt 3, Ch 15, 8 Maintenance of approval*.

7.1.2 Approval by another organisation will not be accepted as sufficient evidence that the arrangements for hull construction comply with these requirements.

■ Section 8
Maintenance of approval**8.1 General**

8.1.1 For Part 2 of the Scheme, the arrangements approved at the shipyard are to be kept under review by the Surveyors to ensure that the approved Quality System is being maintained in a satisfactory manner. This is to be carried out by:

- (a) Regular and systematic audits by the LR Surveyor.
- (b) Comprehensive Annual Audits. The audit team leader will be formally nominated by LR.

8.1.2 Where a comprehensive audit cannot be carried out due to lack of a current building programme to Class, demonstration that the requirements of Part 1 of the Scheme are being maintained may be confirmed by audit review at intervals of six months, normally by the local Surveyors. Where necessary a comprehensive triennial audit would be carried out by a Surveyor formally nominated by LR. The degree of re-assessment for re-approval at the recommencement of building to LR's Class would be at the discretion of the Committee.

8.1.3 All documentation, including reports, is to be available to the Surveyors.

8.1.4 Minor alterations in the approved procedures may be permitted provided that the Surveyors are advised and their prior concurrence obtained. Major alterations would need to be submitted for approval and may require an additional audit.

8.1.5 In a shipyard constructing ships to LR's Class, the following are applicable:

- (a) The LR Surveyor is to be allowed access at all reasonable times to all records pertaining to quality and to all parts of the shipyard involved in the implementation and maintenance of the Quality Assurance Programme.
- (b) The LR Surveyor is immediately to advise the Management Representative of any matter pertaining to the Quality System with which he is not satisfied.
- (c) When minor deficiencies in the approved procedures are discovered during audits, or if workmanship is considered unsatisfactory, the LR Surveyor will apply more intensive auditing and inspection.
- (d) Notwithstanding any of the provisions of the Quality System, all work related to Classification of ships with LR is to be to the satisfaction of the LR Surveyor.

■ Section 9
Suspension or withdrawal of approval**9.1 General**

9.1.1 When the Surveyors have drawn attention to significant faults or deficiencies in the Quality System or its operation and these have not been rectified within a period of time acceptable to LR, the approval of the system, together with the associated certification, will be withdrawn and the shipyard's name deleted from the *List of Shipyards Approved to the Requirements of the Quality Assurance Scheme*.

9.1.2 If a significant period of time elapses between such withdrawal and any application for reinstatement, the reapproval procedures, if agreed to by the Committee, may require a restructuring of the Quality Management System and will always require a complete re-examination as for an initial assessment.

Section

- 1 **General**
 - 2 **Construction monitoring**
 - 3 **Structural design assessment**
 - 4 **Fatigue design assessment**
 - 5 **Whipping design assessment**
 - 6 **Ship Event Analysis**
 - 7 **Enhanced scantlings**
 - 8 **Corrosion protection of internal tanks and spaces**
 - 9 **Ship Emergency Response Service**
 - 10 **Assessment of Ballast Water Management Plans**
 - 11 **Inventory of hazardous materials**
 - 12 **Safe return to port and orderly evacuation**
-

■ Section 1 General

1.1 Application

1.1.1 Where one or more of Lloyd's Register's (hereinafter referred to as 'LR') ShipRight procedures have been satisfactorily applied whether on a mandatory or voluntary basis, the associated ShipRight notation or descriptive note as detailed in *Pt 1, Ch 2, 2.3 Class notations (hull) 2.3.17* or *Pt 1, Ch 2, 2.8 Descriptive notes 2.8.2* will be assigned.

1.1.2 In addition to the ShipRight procedures indicated in this Chapter, details of all LR ShipRight procedures are given in the *ShipRight Procedures Overview document*. Details of machinery ShipRight procedures can also be found in *Pt 5, Ch 21 Requirements for Condition Monitoring Systems and Machinery Condition-Based Maintenance Systems*.

■ Section 2 Construction monitoring

2.1 Construction Monitoring notation – CM

2.1.1 Extended controls on structural alignment, fit up and workmanship standards are to be applied in accordance with the *ShipRight Construction Monitoring Procedure*, to areas of the ship structure that have been requested or have been shown by other ShipRight procedures to be in need of particular attention. The ShipRight Construction Monitoring Procedure is mandatory when one or more of the procedures indicated in *Pt 3, Ch 16, 3 Structural design assessment, Pt 3, Ch 16, 4 Fatigue design assessment, or Pt 3, Ch 16, 5 Whipping design assessment* have been applied, whether voluntarily or on a mandatory basis. Where the relevant procedures have been applied, the ShipRight notation **CM** is to be assigned, see also *Pt 1, Ch 2, 2.3 Class notations (hull) 2.3.17*.

■ Section 3 Structural design assessment

3.1 Structural Design Assessment notation - SDA

3.1.1 Where specified in the Rules the ship structure is to be assessed using finite element modelling in accordance with the applicable ShipRight SDA procedures. Where the relevant procedures have been applied whether on a voluntary or mandatory basis the ShipRight notation **SDA** will be assigned, see also *Pt 1, Ch 2, 2.3 Class notations (hull) 2.3.17*. In general the mandatory application criteria for implementation of one of the associated ShipRight SDA procedures is as follows:

- (a) bulk carriers and oil tankers without a **CSR** notation greater than 190 m in length;
- (b) ore carriers equal to and greater than 150 m in length;
- (c) container ships with a beam greater than 32 m;
- (d) the primary structure of LNG ships fitted by membrane cargo tanks;
- (e) the primary structure of LNG ships fitted with independent Type B spherical cargo tanks;
- (f) the primary structure of LPG ships fitted with Independent Type A cargo tanks;
- (g) passenger ships where it is required to utilise the load carrying capability of the superstructure for longitudinal strength; or where it is considered that the superstructure will be subjected to a significant load from flexure of the hull girder; or, where a limited number of transverse bulkheads above the bulkhead deck are present to carry the racking response;
- (h) other ships of abnormal hull form or where the type, size and structural configuration demand; and
- (i) upon application of any of the following ShipRight notations: **FDA**, **FDA plus()**, **FDA ICE**, **FDA SPR** and **WDA**, see also *Pt 3, Ch 16, 4 Fatigue design assessment* and *Pt 3, Ch 16, 5 Whipping design assessment*.

In addition to the above, and where applicable, the structural capability to withstand dynamic loadings from partially filled tanks or the influence of thermal loadings may also be required to be assessed.

■ Section 4 Fatigue design assessment

4.1 Fatigue Design Assessment notations – FDA, FDA plus, and FDA ICE and FDA SPR

4.1.1 Where specified in the Rules the fatigue performance of the hull structure is to be assessed in accordance with the applicable ShipRight FDA procedures. Where an appraisal has been made whether on a voluntary or mandatory basis of the fatigue performance of the hull structure in accordance with the relevant procedures and found to comply with the requirement of 20 years fatigue life based on the 100A1 Fatigue Wave Environment (World-wide) trading pattern the ShipRight notation **FDA** will be assigned, see also *Pt 1, Ch 2, 2.3 Class notations (hull) 2.3.17*. In general the ShipRight FDA procedure is mandatory for all bulk carriers and oil tankers without a **CSR** notation and of length greater than 190 m or where the type, size and structural configuration demand. The ShipRight notation **FDA** is not applicable to ships approved using the IACS Common Structural Rules.

4.1.2 Where an appraisal is requested for a higher level of fatigue performance of the hull structure than that made for the assignment of the ShipRight notation **FDA**, the relevant procedures for the application of the ShipRight notation **FDA plus()** are to be applied. The appraisal may be made based upon a specific trading pattern, which is to be expressed in terms of either a Worldwide trading route, as defined in the relevant ShipRight procedures, or a North Atlantic trading route (that utilises the wave data from IACS Recommendation 34). The ShipRight notation **FDA plus()** is to be followed by the number of years that the vessel has been assessed for the specific trading pattern shown in brackets, for either the Worldwide or North Atlantic trading routes, denoted by **WW** and **NA** respectively, e.g. **FDA plus(25, NA)**. This procedure is applicable to all ships including those built in accordance with the IACS Common Structural rules.

4.1.3 Where an appraisal is requested for the fatigue performance of the hull structure when navigating through ice, the relevant ShipRight FDA ICE procedures are to be applied. Where the relevant procedures have been applied the ShipRight notation **FDA ICE** will be assigned, see also *Pt 1, Ch 2, 2.3 Class notations (hull) 2.3.17*.

4.1.4 Where specified in the Rules an appraisal is to be made of the fatigue performance of the hull structure taking into account of the effects due to the continuous vibrational response of the hull girder in waves (springing) in accordance with the

relevant ShipRight procedures. Where the relevant procedures have been applied the ShipRight notation **FDA SPR** will be assigned, see also *Pt 1, Ch 2, 2.3 Class notations (hull) 2.3.17*.

■ Section 5 Whipping design assessment

5.1 Whipping Design Assessment notations – WDA

5.1.1 Where specified in the Rules an appraisal is to be made of the vibrational response of the hull structure due to wave impact loads (Whipping) in accordance with the relevant ShipRight procedures. Where the relevant procedures have been applied the ShipRight notation **WDA** will be assigned, see also *Pt 1, Ch 2, 2.3 Class notations (hull) 2.3.17*.

■ Section 6 Ship Event Analysis

6.1 Ship Event Analysis

6.1.1 At the Owner's request and in order to enhance safety and awareness on board during ship operation, the *ShipRight Ship Event Analysis Procedure* applies to all ships where it is intended to provide a hull surveillance system for:

- (a) Monitoring of the ship's hull girder stresses and motions, and warning the ship's personnel that these stress levels or the frequency and magnitude of slamming motions are approaching a level where corrective action is advisable.
- (b) Monitoring of the ship's hull girder stresses and local ice loads when the ship is navigating in ice, and warning the ship's personnel that the load levels or the frequency and magnitude of ice impacts are approaching a level where corrective action is advisable.

■ Section 7 Enhanced scantlings

7.1 Enhanced Scantlings - Descriptive note ES

7.1.1 Where scantlings in excess of the approved Rule minimum are fitted at defined locations, a descriptive note **ES**, Enhanced Scantlings, will be entered in column 6 of the *Register Book*. For example, the note **ES+1** will indicate that an extra 1 mm has been fitted to the hull envelope plating (i.e. deck, side and bottom).

■ Section 8 Corrosion protection of internal tanks and spaces

8.1 Protective coating systems in dedicated sea-water ballast tanks and double-side skin spaces – ShipRight Notations ACS(B) or ACS(B,D)

8.1.1 For ships that are required to comply with IMO Resolution MSC.215(82) - *Performance Standard for Protective Coatings for Dedicated Seawater Ballast Tanks in all Types of Ships and Double-Side Skin Spaces of Bulk Carriers - (Adopted on 8 December 2006)*, all dedicated sea-water ballast tanks for all ship types and double-side skin spaces of bulk carriers are to have type approved coating systems applied in accordance with ShipRight Procedure *Anti-Corrosion Systems Notation*, see *Ch 15 Corrosion Prevention* of the Rules for Materials and *Pt 1, Ch 2, 2.3 Class notations (hull) 2.3.17* for the list of ShipRight ACS notations.

8.1.2 **ShipRight ACS(B)** or **ShipRight ACS(B,D)** will be entered in Column 4 of the *Register Book* to indicate that the ship's sea water ballast tanks and double-side skin spaces of bulk carriers are coated with approved coating systems according to IMO Resolution MSC.215(82) - *Performance Standard for Protective Coatings for Dedicated Seawater Ballast Tanks in all Types of Ships and Double-Side Skin Spaces of Bulk Carriers - (Adopted on 8 December 2006)*

8.2 Protective coating systems in the cargo oil tanks of crude oil tankers – ShipRight Notation ACS(C)

8.2.1 For ships that are required to comply with IMO Resolution MSC.291(87) – *Adoption of Amendments to the International Convention for the Safety of Life at Sea, 1974, as Amended – (Adopted on 21 May 2010)*, Owners may request to receive the optional notation **ShipRight ACS(C)**, which indicates that the cargo oil tanks are protected in compliance with IMO Resolution MSC.288(87) – *Performance Standard for Protective Coatings for Cargo Oil Tanks of Crude Oil Tankers – (Adopted on 14 May 2010)*, and are to have type approved coating systems applied in accordance with ShipRight Procedure *Anti-Corrosion System Notation* and *Ch 15 Corrosion Prevention* of the Rules for Materials.

8.2.2 **ShipRight ACS(C)** will be entered in Column 4 of the *Register Book* to indicate that the ship's cargo oil tanks are protected using approved materials in accordance with IMO Resolution MSC.291(87) – *Adoption of Amendments to the International Convention for the Safety of Life at Sea, 1974, as Amended – (Adopted on 21 May 2010)*

8.2.3 When in compliance with IMO Resolution MSC.291(87) – *Adoption of Amendments to the International Convention for the Safety of Life at Sea, 1974, as Amended – (Adopted on 21 May 2010)*, but the **ShipRight ACS(C)** notation is not requested, this compliance may be indicated on the applicable certification, *Ch 15 Corrosion Prevention* of the Rules for Materials.

8.3 Alternative means of corrosion protection for cargo oil tanks of crude oil tankers – ShipRight notation ACS(C*)

8.3.1 For ships that are required to comply with the IMO Resolution MSC.291(87) – *Adoption of Amendments to the International Convention for the Safety of Life at Sea, 1974, as Amended – (Adopted on 21 May 2010)*, as amended, Owners may request to receive the optional notation **ShipRight ACS(C*)**, which indicates that all cargo tanks are protected in accordance with IMO Resolution MSC.289(87) – *Performance Standard for Alternative Means of Corrosion Protection for Cargo Oil Tanks of Crude Oil Tankers – (Adopted on 14 May 2010)*, by application of corrosion resistant steel, see *Ch 3, 1.3 Corrosion resistant steels for cargo oil tanks of crude oil tankers* of the Rules for Materials and ShipRight Procedure *Anti-Corrosion System Notation*.

8.3.2 **ShipRight ACS(C*)** will be entered in Column 4 of the Register Book to indicate that the ship's cargo oil tanks are protected using approved materials in accordance with IMO Resolution MSC.291(87) – *Adoption of Amendments to the International Convention for the Safety of Life at Sea, 1974, as Amended – (Adopted on 21 May 2010)*, as amended.

8.3.3 When in compliance with IMO Resolution MSC.291(87) – *Adoption of Amendments to the International Convention for the Safety of Life at Sea, 1974, as Amended – (Adopted on 21 May 2010)*, but the **ShipRight ACS(C*)** notation is not requested, this compliance may be indicated on the applicable certificate.

8.4 Protective coatings for void spaces on bulk carriers and oil tankers – ShipRight Notation ACS(V)

8.4.1 For ships within the scope of IMO Resolution MSC.244(83) - *Adoption of Performance Standard for Protective Coatings for Void Spaces on Bulk Carriers and Oil Tankers - (Adopted on 5 October 2007)*, Owners may request to receive the optional notation **ShipRight ACS(V)**, which indicates that the void spaces are protected according to the *ShipRight Procedure Anti-Corrosion System Notation*.

8.4.2 **ShipRight ACS(V)** will be entered in Column 4 of the *Register Book* to indicate that the ship's void spaces are protected in accordance with IMO Resolution MSC.244(83) - *Adoption of Performance Standard for Protective Coatings for Void Spaces on Bulk Carriers and Oil Tankers - (Adopted on 5 October 2007)*.

8.4.3 When in compliance with IMO Resolution MSC.244(83) - *Adoption of Performance Standard for Protective Coatings for Void Spaces on Bulk Carriers and Oil Tankers - (Adopted on 5 October 2007)*, but the **ShipRight ACS(V)** notation is not requested, this compliance may be indicated on the applicable certificate.

8.5 Protective coating systems in dedicated seawater ballast tanks – Descriptive note PCWBT

8.5.1 For ships that are not required to comply with IMO Resolution MSC.215(82) - *Performance Standard for Protective Coatings for Dedicated Seawater Ballast Tanks in all Types of Ships and Double-Side Skin Spaces of Bulk Carriers - (Adopted on 8 December 2006)*, all sea-water ballast spaces having boundaries formed by the hull envelope are to have a corrosion protection coating applied, see ShipRight Procedure *Protective Coatings in Water Ballast Tanks (PCWBT)*.

8.5.2 Where requested, a descriptive note **PCWBT** (Protective Coating in Water Ballast Tanks) will be entered in column 6 of the *Register Book* to indicate that all sea-water ballast spaces having boundaries formed by the hull envelope have a corrosion protection coating applied, and that the coating remains efficient and is maintained in good condition. If the coatings have broken down, particularly at more critical areas, and no effort is being made to maintain the coatings, then this note will be placed in parentheses, i.e. **(PCWBT)**. In either case, the date of the last survey will be placed in parentheses after the note.

■ Section 9 Ship Emergency Response Service

9.1 Ship Emergency Response Service - Descriptive note SERS

9.1.1 This service, offered by LR, provides a rapid computer assisted analysis of a damaged ship's stability and damaged longitudinal strength in the event of a casualty to the ship.

9.1.2 Where an Owner adopts this service, the descriptive note **SERS**, 'Ship is registered with LR's Ship Emergency Response Service', will be entered in column 6 of the *Register Book*.

■ Section 10 Assessment of Ballast Water Management Plans

10.1 Ballast Water Management Plan – Descriptive note BWMP

10.1.1 Compliance with this procedure is optional. A ship meeting the requirements of this procedure will be eligible for an appropriate **ShipRight BWMP** descriptive note, which will be recorded in column 6 of the *Register Book*.

■ Section 11 Inventory of hazardous materials

11.1 Inventory of hazardous materials – Descriptive note IHM

11.1.1 Compliance with this procedure is optional. A ship meeting the requirements of this procedure will be eligible for a ShipRight **IHM** Descriptive Note, which will be recorded in column 6 of the *Register Book*, except as indicated in *Pt 3, Ch 16, 11.1 Inventory of hazardous materials – Descriptive note IHM 11.1.2*.

11.1.2 If a ship has been assigned the **ECO** notation, then it will not be eligible for an **IHM** Descriptive Note. Instead, **IHM** will be referenced in the **ECO** notation, i.e. **ECO(IHM)**.

■ Section 12 Safe return to port and orderly evacuation

12.1 Safe Return to Port and Orderly Evacuation – Descriptive Note SRtP

12.1.1 Compliance with this procedure is optional. A ship meeting the requirements of this procedure will be eligible for a ShipRight **SRtP** Descriptive Note, which will be recorded in column 6 of the *Register Book*.

		CLASSIFICATION
PART	1	REGULATIONS
PART	2	RULES FOR THE MANUFACTURE, TESTING AND CERTIFICATION OF MATERIALS
PART	3	SHIP STRUCTURES (GENERAL)
PART	4	SHIP STRUCTURES (SHIP TYPES)
		CHAPTER 1 GENERAL CARGO SHIPS
		CHAPTER 2 FERRIES, ROLL ON-ROLL OFF SHIPS AND PASSENGER SHIPS
		CHAPTER 3 TUGS
		CHAPTER 4 OFFSHORE SUPPORT VESSELS
		CHAPTER 5 BARGES AND PONTOONS
		CHAPTER 6 TRAWLERS AND FISHING VESSELS
		CHAPTER 7 BULK CARRIERS
		CHAPTER 8 CONTAINER SHIPS
		CHAPTER 9 DOUBLE HULL OIL TANKERS
		CHAPTER 10 SINGLE HULL OIL TANKERS
		CHAPTER 11 ORE CARRIERS
		CHAPTER 12 DREDGING AND RECLAMATION CRAFT
PART	5	MAIN AND AUXILIARY MACHINERY
PART	6	CONTROL, ELECTRICAL, REFRIGERATION AND FIRE
PART	7	OTHER SHIP TYPES AND SYSTEMS
PART	8	RULES FOR ICE AND COLD OPERATIONS

Section

- 1 **General**
- 2 **Materials and protection**
- 3 **Longitudinal strength**
- 4 **Deck structure**
- 5 **Shell envelope plating**
- 6 **Shell envelope framing**
- 7 **Single bottom structure**
- 8 **Double bottom structure**
- 9 **Bulkheads**

■ *Section 1*
General

1.1 Application

1.1.1 This Chapter applies to sea-going ships designed primarily for the carriage of general cargo. The requirements are intended to cover the midship region, but may also apply with suitable modification to the taper regions forward and aft in way of cargo spaces.

1.2 Structural configuration

1.2.1 The Rules provide for a basic structural configuration of a multi-deck or a single deck hull which includes a double bottom, or a single bottom arrangement. The structural configuration may also include a single or multiple arrangement of cargo hatch openings, and side tanks.

1.2.2 Individual consideration may be required where the ship incorporates double hull construction, large deck openings or other special design features.

1.2.3 Longitudinal framing is, in general, to be adopted at the strength deck outside line of openings and at the bottom, but special consideration will be given to proposals for transverse framing in these regions.

1.3 Class notations

1.3.1 In general, ships complying with the requirements of this Chapter will be eligible to be classed **100A1**.

1.3.2 Where a ship has been specially strengthened for heavy cargoes in accordance with the requirements listed in *Pt 4, Ch 7, 8.2 Carriage of heavy cargoes*, it will be eligible to be classed **100A1 strengthened for heavy cargoes**.

1.3.3 The following additional notations and annotations can be appended to the main class notation giving further detailed description of the loading criteria incorporated into the design:

(a) **RD** (Relative density):

Where a ship has tanks appraised for a maximum permissible relative density greater than 1,025, the notation **RD(specified tank names, density)** may be added.

(b) **WDL(+)** (Weather deck load):

The notation **WDL(+)** may be added. If requested, the maximum permissible weather deck load and extent can be identified in the notation, e.g. **WDL(5,0 t/m² from Aft to Fr. 26)**.

1.3.4 Ships intended to be operated only in suitable areas or conditions which have been agreed by the Committee, as defined in *Pt 1, Ch 2, 2.3 Class notations (hull) 2.3.6 to 2.3.10*, will receive individual consideration on the basis of the Rules with respect to the environmental conditions agreed for the design basis and approval.

1.3.5 The Regulations for classification and the assignment of class notations are given in *Pt 1, Ch 2 Classification Regulations*, to which reference should be made.

1.4 Information required

1.4.1 For the information required, see *Pt 3, Ch 1, 5 Information required*. In addition the following are to be supplied:

- (a) Cargo loadings on decks, hatchways and inner bottom if these are to be in excess of Rule. Where concentrated or point loads occur, their magnitude and points of application are to be defined.
- (b) The maximum pressure head in service on tanks, also details of any double bottom tanks interconnected with side tanks.
- (c) Details of the proposed depths of any partial fillings where water ballast or liquid cargo is intended to be carried in the holds, or large deep tanks.

1.5 Symbols and definitions

1.5.1 The following symbols and definitions are applicable to this Chapter unless otherwise stated:

L, B, D, T = as defined in *Pt 3, Ch 1, 6 Definitions*
and V

k_L, k = higher tensile steel factor, see *Pt 3, Ch 2, 1 Materials of construction*

e = base of natural logarithms 2,7183

l = overall length of stiffening member, or pillar, in metres, see *Pt 3, Ch 3, 3 Structural idealisation*

l_e = effective length of stiffening member, or pillar, in metres, see *Pt 3, Ch 3, 3 Structural idealisation*

t = thickness of plating, in mm

s = spacing of secondary stiffeners, in mm

A = cross-sectional area of stiffening member, in cm^2

C = stowage rate, in m^3/tonne , see *Pt 3, Ch 3, 5 Design loading*

C_w = a wave head in metres

= $7,71 \times 10^{-2} L e^{-0,0044 L}$ where L is not to be taken greater than 227

I = inertia of stiffening member, in cm^4 , see *Pt 3, Ch 3, 3 Structural idealisation*

S = spacing or mean spacing of primary members, in metres

Z = section modulus of stiffening member, in cm^3 , see *Pt 3, Ch 3, 3 Structural idealisation*

ρ = relative density (specific gravity) of liquid carried in a tank but is not to be taken less than 1,025.

■ Section 2 Materials and protection

2.1 Materials and grades of steel

2.1.1 Materials and grades of steel are to comply with the requirements of *Pt 3, Ch 2 Materials*.

2.2 Protection of steelwork

2.2.1 For the protection of steelwork, in addition to the requirements specified in *Pt 3, Ch 2, 3 Corrosion protection* the requirements of *Pt 4, Ch 1, 2.2 Protection of steelwork 2.2.2* are to be complied with.

2.2.2 Ceiling is to be laid on the inner bottom under cargo hatchways, but may be omitted provided that the inner bottom plating is increased by 2 mm. In any ship which is regularly to be discharged by grabs, ceiling is to be laid on the inner bottom, and the inner bottom plating increased by 3 mm. Alternatively, the ceiling may be omitted provided that the inner bottom plating is increased in thickness by a minimum of 5 mm. The ceiling is to be 76 mm thick in softwood or 65 mm thick in hardwood, and is to be laid at right angles to the inner bottom stiffening. Where it is intended to use plywood or other forms of ceiling of an approved type instead of planking, the thickness will be considered for each case. Ceiling is also to be laid over bilges, and fitted with portable sections which are to be readily removable. The spaces between the frames at the top of the bilge ceiling are to be closed by steel plates, wood chocks, cement or other suitable means. Inner bottom manhole covers or fittings, where projecting above the inner bottom plating, are to be provided with a steel protection coaming around each manhole, and a wood or steel cover is to be fitted.

2.2.3 Where plated decks are sheathed with wood or approved compositions, the minimum thicknesses given in *Pt 4, Ch 1, 4.2 Deck plating, Pt 3, Ch 5, 2 Deck structure* and *Pt 3, Ch 6, 2 Deck structure* may be reduced by 10 per cent for a 50 mm sheathing thickness or five per cent for 25 mm, with intermediate values in proportion. The steel deck is to be coated with a suitable material in order to prevent corrosive action, and the sheathing or composition is to be effectively secured to the deck. See also the fire protection requirements relating to deck coverings in the relevant SOLAS - *International Convention for the Safety of Life at Sea Regulations* or *Pt 6, Ch 3, 4 Refrigeration plant, pipes, valves and fittings* as applicable.

2.2.4 Where cargo battens or equivalent are fitted in the holds of dry cargo ships, the descriptive note 'SF' will be entered in the *Register Book*. The battens, when fitted, are to extend from above the upper part of the bilge to the underside of beam knees in the holds, and in all cargo spaces in the 'tween decks and superstructures, up to the underside of beam knees. Wood cargo battens are to be not less than 50 mm in thickness, and the clear space between adjacent rows is, in general, not to exceed 230 mm. The dimensions and spacing of battens made of other materials will be considered. Nets may be adopted in lieu of battens, and other alternative proposals will be specially considered. For arrangements in way of a refrigerated hold, see *Pt 6, Ch 3, 4 Refrigeration plant, pipes, valves and fittings*.

■ Section 3 Longitudinal strength

3.1 General

3.1.1 Longitudinal strength calculations are to be made in accordance with the requirements given in *Pt 3, Ch 4 Longitudinal Strength*.

3.1.2 The requirements of *Pt 3, Ch 4, 8.3 Loading instrument* regarding loading instruments are not applicable to general cargo ships under 120 m.

3.2 Fast cargo ships

3.2.1 The hull section modulus for ships of length, L , between 120 m, and 170 m, and maximum service speed greater than 17,5 knots in association with a bow shape factor, ψ , of more than 0,15, is to comply with the requirements of this sub-Section.

3.2.2 The bow shape factor is defined as:

$$\psi = \frac{100 \sum A_b}{L^{1,5} B}$$

where

a_0 = projection of upper deck at waterline (F.P.), in metres

a_1 = projection of upper deck at waterline (0,1L from F.P.), in metres

a_2 = projection of upper deck at waterline (0,2L from F.P.), in metres

where

b = projection of upper deck at waterline (F.P. to bow line), in metres

$$= \Sigma A_b = \frac{ba_0}{2} + 0,1L(a_1 + a_2) \text{ m}^2$$

See also Figure 1.3.1 Derivation of bow shape factor.

3.2.3 For longitudinal strength requirements, the Rule minimum hull midship section modulus and the distribution of longitudinal material in the forward half-length will be considered. In general, the following requirements are to be complied with:

- (a) The vertical hull midship section modulus, about the horizontal neutral axis, at deck is to be not less than $331Lk\Sigma A_b \text{ cm}^3$, or that required by Pt 3, Ch 4, 5 Hull bending strength, whichever is the greater. ΣA_b is defined in Pt 4, Ch 1, 3.2 Fast cargo ships 3.2.2.
- (b) The horizontal hull midship section modulus, about a vertical axis through the ship centreline, is to be not less than $32,5 L^2 D \text{ cm}^3$.
- (c) In the forward half-length, the hull section modulus is not to be a lesser percentage of the midship value than that shown in Table 1.3.1 Fast cargo ships.
- (d) Any load or ballast condition resulting in a sagging still water bending moment, or a hogging moment less than 80 per cent of the Rule value of still water bending moment, will be specially considered with a view to minimising the compressive stresses in the deck in waves.

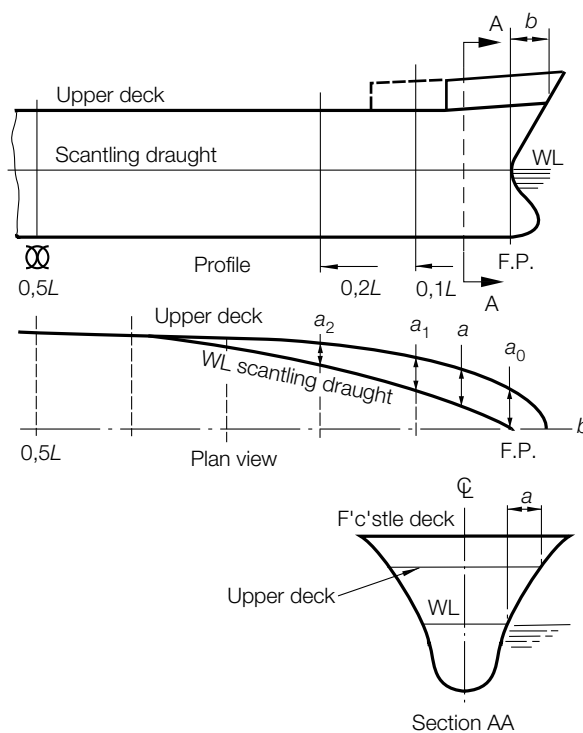

Figure 1.3.1 Derivation of bow shape factor

Table 1.3.1 Fast cargo ships

Position	Percentage of midship vertical modulus(modulus about horizontal axis)	Percentage of midship horizontal modulus(modulus about vertical axis)
Station 10 (mid- L_{pp})	100	100
12	98	87
14	95	62
16	81	38
18	44	17
20 (F.P.)	0	0

Note 1. Intermediate values to be obtained by interpolation.
Note 2. L_{pp} as defined in Pt 3, Ch 1, 6 Definitions.

3.2.4 For local strength, in general the following requirements are to be complied with:

- (a) Longitudinal deck stiffening is to be carried forward to the fore peak bulkhead or as far forward as practical. Where a long forecastle is fitted, the buckling strength of the proposed structure will be specially considered.
- (b) Substantial web frames in way of deck transverses are to be fitted in the forward half-length. Scantlings of webs and frames are to be based on actual lengths, not 'tween deck heights, and collars are to be fitted at ends of members in way of high shear.
- (c) Scantlings of bottom structure in forward part are to be specially considered.
- (d) Deck and side shell panels forward of 0,5L from F.P. are to be examined to establish the critical buckling stress from the following formula:

$$\sigma_c = \frac{\pi^2 E}{12(1 - \nu^2)} \left(\frac{t}{s}\right)^2 K_c \quad \text{N/mm}^2(\text{kgf/mm}^2)$$

where

s = length of shorter edge, in mm

t = thickness of plating, in mm

E = Young's modulus, in N/mm² (kgf/mm²)

K_c = a factor depending on aspect ratio and boundary restraint

= 4 for longitudinally stiffened plating or as shown in *Figure 1.3.2 Plate factor*, K_c for transversely stiffened plating

ν = Poisson's ratio (0,3 for steel and aluminium alloy).

Where the buckling stresses, as evaluated, exceed 50 per cent of yield stress, the actual critical buckling stress is given by:

$$\sigma_{ac} = \sigma_o \left(1 - \frac{\sigma_o}{4\sigma_c}\right) \quad \text{N/mm}^2(\text{kgf/mm}^2)$$

where

σ_{ac} = corrected critical buckling stress, in N/mm² (kgf/mm²)

σ_o = yield stress, in N/mm² (kgf/mm²)

The critical buckling stress from the above formulae must be not less than 176,6 N/mm² (18,0 kgf/mm²) within 0,4L amidships, nor less than 147,2 N/mm² (15,0 kgf/mm²) for the deck forward of this, nor less than 117,7 N/mm² (12,0 kgf/mm²) for the deck aft of this.

mm²) for the side shell between the first and second deck forward of 0,5L from F.P. For higher tensile steel plating, the above permissible stresses are to be divided by *k*.

- (e) In order to obtain the necessary critical buckling strength, either of the following is to be applied:
- (i) plate thickness to be increased, or
 - (ii) panel aspect ratio to be altered by the fitting of additional panel stiffening.

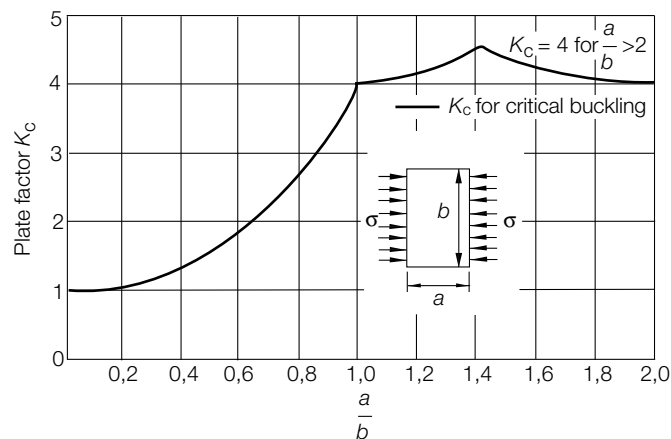

Figure 1.3.2 Plate factor, K_c

■ **Section 4**
Deck structure

4.1 General

4.1.1 Longitudinal framing is, in general, to be adopted at the strength deck outside line of openings, but special consideration will be given to proposals for transverse framing. Requirements are given in this Section for longitudinal and transverse framing systems of all deck structure, except decks in way of erections. For erection decks, see *Pt 3, Ch 8 Superstructures, Deckhouses and Bulwarks*.

4.2 Deck plating

4.2.1 The thickness of strength/weather deck plating in the midship region is to comply with the requirements of *Table 1.4.1 Strength/weather deck plating*. Outside the line of openings the thickness is also to be that necessary to give the hull section modulus required by *Pt 3, Ch 4, 5 Hull bending strength*.

4.2.2 The thickness of lower deck plating in the midship region is to comply with the requirements of *Table 1.4.2 Lower deck plating*.

4.2.3 The thickness of the strength deck stringer plate is to be increased by 20 per cent at the ends of bridges, poop and forecastle.

4.2.4 The deck plating thickness and supporting structure are to be suitably reinforced in way of cranes, masts, derrick posts and deck machinery.

4.2.5 Where long, wide hatchways are arranged on lower decks, it may be necessary to increase the deck plating thickness to ensure effective support for side framing.

4.3 Deck stiffening

4.3.1 The scantlings of strength/weather deck longitudinals in the midship region are to comply with the requirements of *Table 1.4.3 Strength/weather deck longitudinals*.

4.3.2 The lateral and torsional stability of longitudinals together with web and flange buckling criteria are to be verified in accordance with *Pt 3, Ch 4, 7 Hull buckling strength*.

4.3.3 The scantlings of cargo and accommodation deck longitudinals are to comply with the requirements of *Table 1.4.4 Cargo and accommodation deck longitudinals*.

4.3.4 End connection of longitudinals to bulkheads are to provide adequate fixity and, so far as is practicable, direct continuity of longitudinal strength. Where L exceeds 215 m, the deck longitudinals are to be continuous through transverse structure, including bulkheads, but alternative arrangements will be considered. Higher tensile steel deck longitudinals are to be continuous irrespective of the ship length.

4.3.5 The scantlings of strength/weather, cargo and accommodation deck transverse beams are to comply with the requirements of *Table 1.4.5 Strength/weather, cargo and accommodation deck beams*.

4.3.6 The end connections of beams are to be in accordance with the requirements of *Pt 3, Ch 10, 3 Secondary member end connections*.

Table 1.4.1 Strength/weather deck plating

Location	Minimum thickness, in mm, see also Pt 4, Ch 1, 4.2 Deck plating 4.2.1	
	Longitudinal framing	Transverse framing
(1) Outside line of openings (see Notes 1 and 2)	The greater of the following: $(a) t = 0,001s_1(0,059L_1 + 7) \sqrt{\frac{F_D}{k_L}}$ $(b) t = 0,00083s_1 \sqrt{Lk} + 2,5$	The greater of the following: $(a) t = 0,001s_1 f_1 (0,083L_1 + 10) \sqrt{\frac{F_D}{k_L}}$ $(b) t = 0,001s_1 \sqrt{Lk} + 2,5$
(2) Inside line of openings (see Note 2)	$(b) t = 0,00083s_1 \sqrt{Lk} + 2,5$ but not less than 6,5	$t = 0,00083s_1 \sqrt{Lk} + 1,5$ but not less than 6,5
(3) In way of the crown of a tank	$t = 0,004sf \sqrt{\frac{pkh_4}{1,025}} + 3,5$ or as (1) or (2), whichever is the greater, but not less than 7,5 mm where $L \geq 90m$, or 6,5 mm where $L < 90 m$	
Symbols		
L, k_L, k, ρ, s, S = as defined in Pt 4, Ch 1, 1.5 Symbols and definitions 1.5.1 $f = 1,1 - \frac{s}{2500S}$ but not to be taken greater than 1,0 $f_1 = \frac{1}{1 + \left(\frac{s}{1000S}\right)^2}$ h_4 = tank head, in metres, as defined in Pt 3, Ch 3, 5 Design loading s_1 = s but is not to be taken less than the smaller of $470 + \frac{L}{0,6}$ mm or 700 mm F_D = as defined in Pt 3, Ch 4, 5.7 Local reduction factors L_1 = L but need not be taken greater than 190 m.		
<p>Note 1. The thickness derived in accordance with (1) is also to satisfy the buckling requirements of Pt 3, Ch 4, 7 Hull buckling strength.</p> <p>Note 2. The deck thickness is to be not less than the basic end deck thickness as given in Pt 3, Ch 5 Fore End Structure and Pt 3, Ch 6 Aft End Structure.</p>		

Table 1.4.2 Lower deck plating

Location	Minimum thickness, in mm	
	Second deck	Third or platform decks
(1) Outside line of openings	$t = 0,012s_1 \sqrt{k}$ but not less than 6,5	$t = 0,01s_1 \sqrt{k}$ but not less than 6,5
(2) Inside line of openings	$t = 0,01s_1 \sqrt{k}$ but not less than 6,5	
(3) In way of the crown or bottom of a tank	$t = 0,004sf \sqrt{\frac{\rho kh_4}{1,025} + K_1}$ but not less than 7,5 where $L \geq 90$ m, or 6,5 where $L < 90$ m	
(4) Plating forming the upper flange of underdeck girders	Clear of deck openings, $t = \sqrt{\frac{A_f}{1,8k}}$ In way of deck openings, $t = 1,1 \sqrt{\frac{A_f}{1,8k}}$ Minimum breadth, $b = 760$ mm	
Symbols		
s, S, k, ρ , as defined in Pt 4, Ch 1, 1.5 Symbols and definitions 1.5.1		
b = breadth of increased plating, in mm		
$f = 1,1 - \frac{s}{2500S}$ but not to be taken greater than 1,0		
h_4 = tank head, in metres, as defined in Pt 3, Ch 3, 5 Design loading		
s_1 = s but is not to be taken less than the smaller of $470 + \frac{L}{0,6}$ mm or 700 mm		
A_f = girder face area, in cm^2		
K_1 = 2,5 mm at bottom of tank = 3,5 mm at crown of tank		
Note Where a deck loading exceeds $43,2 \text{ kN/m}^2$ ($4,4 \text{ tonne-f/m}^2$), the thickness of plating will be specially considered.		

Table 1.4.3 Strength/weather deck longitudinals

Location	Modulus, in cm ³	Inertia, in cm ⁴
(1) In way of dry cargo spaces, see Note 1		
(a) Outside line of openings	$Z = 0,043 s k h_{T1} l_e^2 F_1$	—
(b) Inside line of openings	$Z = s k(400h_1 + 0,005 (l_e L_2)^2) \times 10^{-4}$	—
(2) In way of the crown or bottom of a tank	$Z = \frac{0,0113 \rho s k h_4 l_e^2}{b}$ or as (1)(a) or (1)(b) above, whichever is the greater	$I = \frac{2,3}{k} l_e Z$
(3) In way of superstructure	To be specially considered	—
Symbols		
<p><i>L, s, k_L, k, ρ</i> as defined in Pt 4, Ch 1, 1.5 Symbols and definitions 1.5.1</p> <p><i>b</i> = 1,4 for rolled or built sections = 1,6 for flat bars</p> $c_1 = \frac{60}{225 - 165F_D}$ <p><i>d_w</i> = depth of longitudinal, in mm</p> $F_1 = 0,25c_1$ <p><i>h₁</i> = weather head, in metres, as defined in Pt 3, Ch 3, 5 Design loading</p> <p><i>h₄</i> = tank head, in metres, as defined in Pt 3, Ch 3, 5 Design loading</p> <p><i>l_e</i> = as defined in Pt 4, Ch 1, 1.5 Symbols and definitions 1.5.1, but not to be taken less than 1,5 m</p> <p><i>F_D</i> = as defined in Pt 3, Ch 4, 5.7 Local reduction factors</p> $h_{T1} = \frac{L_1}{56} \text{ for Type 'B-60' ships}$ $= \text{the greater of } \frac{L_1}{70} \text{ or } 1,20 \text{ m for Type 'B' ships}$ <p><i>L₁</i> = <i>L</i> but need not be taken greater than 190 m</p> <p><i>L₂</i> = <i>L</i> but need not be taken greater than 215 m</p>		
<p>Note 1. Where weather decks are intended to carry deck cargo and the load is in excess of 8,5 kN/m² (0,865 tonne-f/m²), the scantlings of longitudinals may be required to be increased to comply with the requirements for location (1) Table 1.4.4 Cargo and accommodation deck longitudinals using the equivalent design head, for specified cargo loading, for weather decks given in Table 3.5.1 Design heads and permissible cargo loadings in Pt 3, Ch 3 Structural Design .</p>		

Note 2. The buckling requirements of Pt 3, Ch 4, 7 *Hull buckling strength* are to be complied with. The ratio of the web depth d_w to web thickness t is to comply with the following requirements: (a) Built up profiles and rolled angles:

$$\frac{d_w}{t} \leq 60\sqrt{k_L} \quad \text{(b) Flat bars:}$$

$$\frac{d_w}{t} \leq 18\sqrt{k_L} \quad \text{when continuous at bulkheads}$$

$$\frac{d_w}{t} \leq 15\sqrt{k_L} \quad \text{when non-continuous at bulkheads}$$

Note 3. The web depth of longitudinals, d_w is to be not less than 60 mm.

Table 1.4.4 Cargo and accommodation deck longitudinals

Location	Modulus, in cm ³	Inertia, in cm ⁴
(1) Cargo decks		
(a) $L \geq 90$ m	$Z = sk(5,9L_1 + 25h_2 l_e^2) \times 10^{-4}$	—
(b)	$Z = 0,005s k h_2 l_e^2$	—
(2) Accommodation decks		
(a) $L \geq 90$ m	$Z = sk(5,1L_1 + 25h_3 l_e^2) \times 10^{-4}$	—
(b) $L < 90$ m	$Z = 0,00425s k h_3 l_e^2$ See Note 1	—
(3) In way of the crown or bottom of a tank	As in (1) or (2) as applicable, or $Z = \frac{0,0113 \rho s k h_4 l_e^2}{\gamma}$ whichever is the greater	$I = \frac{2,3}{k} l_e Z$
Symbols		
<p>L, s, k, ρ as defined in Pt 4, Ch 1, 1.5 Symbols and definitions 1.5.1</p> <p>d_w = web depth of longitudinal, in mm, see Note 2</p> <p>h_2 = cargo head, in metres, as defined in Pt 3, Ch 3, 5 Design loading</p> <p>h_3 = accommodation head, in metres, as defined in Pt 3, Ch 3, 5 Design loading</p> <p>h_4 = tank head, in metres, as defined in Pt 3, Ch 3, 5 Design loading</p> <p>l_e = as defined in Pt 4, Ch 1, 1.5 Symbols and definitions 1.5.1, but not to be taken less than 1,5 m</p> <p>L_1 = L but need not be taken greater than 190 m</p> <p>γ = 1,4 for rolled or built sections = 1,6 for flat bars</p>		

Note 1. The section modulus of accommodation deck longitudinals need not be taken greater than the value required by location (1)(a), in Table 1.4.3 Strength/weather deck longitudinals.

Note 2. The web depth of longitudinals, d_w , to be not less than 60 mm.

Table 1.4.5 Strength/weather, cargo and accommodation deck beams

Location	Modulus, in cm^3	Inertia, in cm^4
(1) Strength/weather decks	The lesser of the following: (a) $Z = (K_1 K_2 TD + K_3 B_1 s h_1 l_e^2) k \times 10^{-4}$ (b) $Z = 2K_3 B_1 s k h_1 l_e^2 \times 10^{-4}$	—
(2) Cargo decks	$Z = (400K_1 TD + 38,8s h_2 l_e^2) k \times 10^{-4}$	—
(3) Accommodation decks	$Z = (530K_1 TD + 38,8s h_3 l_e^2) k \times 10^{-4}$	—
(4) In way of the crown or bottom of a tank	As (1), (2) or (3) as applicable, or $Z = \frac{0,0113p s k h_4 l_e^2}{\gamma}$ whichever is the greater	$I = \frac{2,3}{k} l_e Z$

B, D, T, s, k, ρ as defined in Pt 4, Ch 1, 1.5 Symbols and definitions 1.5.1

d_w = depth of beam, in mm

h_1 = weather deck head in metres, see Pt 3, Ch 3, 5 Design loading

h_2 = cargo head in metres, see Pt 3, Ch 3, 5 Design loading

h_3 = accommodation head in metres, see Pt 3, Ch 3, 5 Design loading

h_4 = tank head in metres, see Pt 3, Ch 3, 5 Design loading

l_e as defined in Pt 4, Ch 1, 1.5 Symbols and definitions 1.5.1, but to be taken as not less than 1,83 m

B_1 = B , but need not be taken greater than 21,5 m

K_1 = a factor dependent on the number of decks (including poop and bridge superstructures) at the position of the beam under consideration:

= 1 deck 20,0

= 2 decks 13,3

= 3 decks 10,5

= 4 or more 9,3

K_2 = a factor dependent on the location of the beam:

= at short bridge and poops 133

= elsewhere 530

K_3 = a factor dependent on the location of the beam:

= elsewhere 3,3

= span adjacent to the ship side 3,6

γ = 1,4 for rolled or built sections

= 1,6 for flat bars

Note 1. Where weather decks are intended to carry deck cargo and the load is in excess of 8,5 kN/m² (0,865 tonne-f/m²), the scantlings of beams may be required to be increased to comply with the requirements for location (2) using the equivalent design head, for specified cargo loading, for weather decks given in *Table 3.5.1 Design heads and permissible cargo loadings*.

Note 2. The web depth of beams, d_w , is to be not less than 60 mm.

4.4 Deck supporting structure

4.4.1 **Girders and transverses** supporting deck longitudinals and beams, also hatch side girders and hatch end beams, are to comply with the requirements of *Table 1.4.6 Deck girders, transverses and hatch beams*. In general, transverses, webs or frames of increased scantlings, see *Table 1.6.3 Shell framing (transverse)*, are to be arranged in way of hatch end beams and deck transverses, and these are to be in line with the double bottom floors where practicable. Equivalent transverse ring scantling arrangements will be considered.

4.4.2 **Transverses** supporting deck longitudinals are, in general, to be spaced not more than 3,8 m apart where the length, L , is 100 m or less, and $(0,006L + 3,2)$ m apart where L is greater than 100 m.

4.4.3 The web thickness, stiffening arrangements and end connection of primary supporting members are to be in accordance with *Pt 3, Ch 10, 4 Construction details for primary members*.

4.4.4 Where a girder is subject to concentrated loads, such as pillars out of line, the scantlings are to be suitably increased. Also, where concentrations of loading on one side of the girder may occur, the girder is to be adequately stiffened against torsion. Reinforcements may be required in way of localised areas of high stress.

4.4.5 **Pillars** are to comply with the requirements of *Table 1.4.7 Pillars*.

4.4.6 Pillars are to be fitted in the same vertical line wherever possible, and effective arrangements are to be made to distribute the load at the heads and heels of all pillars. Where pillars support eccentric loads, they are to be strengthened for the additional bending moment imposed upon them.

4.4.7 Tubular and hollow square pillars are to be attached at their heads to plates supported by efficient brackets, in order to transmit the load effectively. Doubling or insert plates are to be fitted to the inner bottom under the heels of tubular or hollow square pillars, and to decks under large pillars. The pillars are to have a bearing fit and are to be attached to the head and heel plates by continuous welding. At the heads and heels of pillars built of rolled sections, the load is to be well distributed by means of longitudinal and transverse brackets.

4.4.8 In double bottoms under widely spaced pillars, the connections of the floors to the girders, and of the floors and girders to the inner bottom, are to be suitably increased. Where pillars are not directly above the intersection of plate floors and girders, partial floors and intercostals are to be fitted as necessary to support the pillars. Manholes are not to be cut in the floors and girders below the heels of pillars. Where longitudinal framing is adopted in the double bottom, equivalent stiffening under the heels of pillars is to be provided, and where the heels of pillars are carried on a tunnel, suitable arrangements are to be made to support the load.

4.4.9 Where pillars are fitted inside tanks or under watertight flats, the tensile stress in the pillar and its end connections is not to exceed 108 N/mm² (11,0 kgf/mm²) at the test heads. In general, such pillars should be of built sections, and end brackets may be required.

4.4.10 Pillars are to be fitted below deckhouses, windlasses, winches, capstans and elsewhere where considered necessary.

4.4.11 **Non-watertight pillar bulkheads** are to comply with the requirements of *Table 1.4.8 Non-watertight pillar bulkheads*.

4.4.12 **Cantilevers** and their supporting frames are to comply with the requirements of *Table 1.4.9 Cantilever beams*.

4.5 Deck openings

4.5.1 The corners of main cargo hatchways in the strength deck within 0,5L amidships are to be elliptical, parabolic or rounded, with a radius generally not less than $\frac{1}{24}$ of the breadth of the opening. Rounded corners are to have a minimum radius of 300 mm if the deck plating extends inside the coaming, or 150 mm if the coamings are welded to the inner edge of the plating in the form of a spigot. Where elliptical corners are arranged, the major axis is to be fore and aft, the ratio of the major to minor axis is to be not less than 2 to 1 nor greater than 2,5 to 1, and the minimum half-length of the major axis is to be defined by l_1 in *Figure 1.4.5 Elliptical and parabolic corners*. Where parabolic corners are arranged, the dimensions are also to be as shown in *Figure 1.4.5 Elliptical and parabolic corners*.

4.5.2 Where the corners of large openings in the strength deck are parabolic or elliptical, insert plates are not required. For other shapes of corner, insert plates of the size and extent shown in *Figure 1.4.6 Insert plates for large openings* will, in general, be required. The required thickness of the insert plate is to be not less than 25 per cent greater than the adjacent deck thickness, outside line of openings with a minimum increase of 4 mm. The increase need not exceed 7 mm.

4.5.3 Welded attachments close to or on the free edge of the hatch corner plating are to be avoided (e.g. welded protection strips or shedder plates) and the butt welds of corner insert plates to the adjacent deck plating are to be located well clear of butts in the hatch coaming.

4.5.4 Openings in the strength deck outside the line of hatch openings are to be kept to the minimum number consistent with operational requirements. Openings are to be arranged clear of hatch corners and, so far as possible, clear of one another. Where, within 0,4L amidships, deck openings have a total breadth or shadow area breadth, in one transverse section that exceeds the limitation given in *Pt 3, Ch 3, 3.4 Calculation of hull section modulus 3.4.4* and *Pt 3, Ch 3, 3.4 Calculation of hull section modulus 3.4.5*, compensation will be required to restore the excess. This is generally to be arranged by increasing the deck plate thickness, but other proposals will be considered. Plate panels in which openings are cut are to be adequately stiffened, where necessary, against compression and shear buckling. The corners of all openings are to be well rounded and the edges smooth.

Table 1.4.6 Deck girders, transverses and hatch beams

Location and arrangements	Modulus, in cm ³	Inertia, in cm ⁴
(1) Girders and transverses in way of dry cargo spaces and clear of hatch openings:	See also Note	
(a) supporting up to three point loads	Z to be determined from calculations using Note and stress $\frac{123,5}{k}$ N/mm ² ($\frac{12,6}{k}$ kgf/mm ²) and assuming fixed ends.	$I = \frac{1,85}{k} l_e Z$
(b) supporting four or more point loads or a uniformly distributed load	$Z = 4,75k S H_g l_e^2$	
(2) Hatch side girders in way of dry cargo spaces at weather decks (with deep coamings):		
(a) supporting up to three point loads	Z to be determined from calculations using Note and stress $\frac{100,4}{k}$ N/mm ² ($\frac{10,25}{k}$ kgf/mm ²) and assuming fixed ends	$I = \frac{2,3}{k} l_e Z$
(b) supporting four or more point loads or a uniformly distributed load	$Z = 5,85k S_1 H_g l_e^2$	
(3) Hatch side girders in way of dry cargo spaces at lower decks (without deep coamings):		
(a) supporting up to three point loads	Z to be determined from calculations using stress $\frac{112,5}{k}$ N/mm ² ($\frac{11,5}{k}$ kgf/mm ²)	$I = \frac{1,85}{k} l_e Z$

(b) supporting four or more point loads or a uniformly distributed load	$Z = 5,20kS_1H_g l_e^2$	
(4) Hatch end beams in way of dry cargo spaces and supported at centreline, see <i>Figure 1.4.1 Hatch end beam arrangements</i> : (a) In association with longitudinal framing when there is no transverse between the hatch end beam and adjacent transverse bulkhead or equivalent supporting structure (b) In association with longitudinal framing where there is one or more transverse between the hatch end beam and adjacent transverse bulkhead or equivalent supporting structure (c) In association with transverse framing when the hatch end beam supports the hatch side girder and in line girder only (d) In association with transverse framing when the hatch end beam supports the hatch side girder, an in line girder and an additional girder between the hatch side and the centreline	$Z = 19k K_1 H_g l_e S_1 l_1 + 2,37k S_e H_g l_e^2$ $Z = 19k K_1 H_g l_e (S_1 l_1 + S_2 l_2)$ $Z = 19k K_1 H_g l_e (S_1 l_1 + S_3 l_3)$ $Z = 19k H_g l_e (K_1 (S_1 l_1 + S_4 l_4) + K_2 S_5 l_5)$	$I = \frac{2,8}{k} l_e Z$
(5) Girders and transverses in way of the crown or bottom of a tank	$Z = 11,7\rho k h_4 S l_e^2$	$I = \frac{2,8}{k} l_e Z$
Symbols		
S, l_e, k, ρ as defined in Pt 4, Ch 1, 1.5 Symbols and definitions 1.5.1	$K_1, K_2 =$ factors, dependent on the girder arrangements, as follows:	
$h_4 =$ tank head, in metres, as defined in Pt 3, Ch 3, 5 Design loading	$\frac{B_h}{2l_e}$ or $\frac{X}{l_e}$	K_1 or K_2
l_1, l_2, l_3, l_4, l_5 , in metres, as indicated in <i>Figure 1.4.1 Hatch end beam arrangements</i>	0,2	0,143
	0,3	0,177
$B_h =$ breadth of hatchway, in metres, as used to determine K_1	0,4	0,191
	0,5	0,187
$H_g =$ weather head h_1 , or cargo head h_2 , or accommodation head h_3 , in metres, as defined in Pt 3, Ch 3, 5 Design loading, whichever is applicable	0,6	0,179
	0,7	0,169
	0,8	0,141
	0,9	0,085
	1,0	0,000
	$S_e, S_1, S_2, S_3, S_4, S_5$, in metres as indicated in <i>Figure 1.4.1 Hatch end beam arrangements</i>	
	$X =$ distance, in metres, from centreline of ship to an additional girder, if fitted, as shown in <i>Figure 1.4.1 Hatch end beam arrangements</i> , as used to determine K_2	
NOTE		
In single deck ships the section modulus of deck transverses is to be increased by 15 per cent.		

Table 1.4.7 Pillars

Symbols	Parameter	Requirement
<p>b = breadth of side of a hollow rectangular pillar or breadth of flange or web of a built or rolled section, in mm</p> <p>d_p = mean diameter of tubular pillars, in mm</p>	<p>(1) Cross-sectional area of all types of pillar</p>	$A_p = \frac{kP}{12,36 - 51,5 \frac{l_e}{r\sqrt{k}}} \text{ cm}^2$ $\left(A_p = \frac{kP}{1,26 - 5,25 \frac{l_e}{r\sqrt{k}}} \text{ cm}^2 \right)$ <p>See Note</p>
<p>k = local scantling higher tensile steel factor, see Pt 3, Ch 2, 1.2 Steel 1.2.3, but not less than 0,72</p> <p>l = overall length of pillar, in metres</p> <p>l_e = effective length of pillar, in metres, and is taken as: for hold pillars 0,65 l for 'tween deck pillars 0,80 l</p> <p>l_p = distance, in metres, between centres of the two adjacent spans of girder, or transverse, supported by the pillar</p>	<p>(2) Minimum wall thickness of tubular pillars</p>	<p>The greater of the following:</p> <p>(a) $t = \frac{P}{d_p \left(0,392 - 1,53 \frac{l_e}{r} \right)}$ mm</p> <p>(a) $t = \frac{P}{d_p \left(0,04 - 0,156 \frac{l_e}{r} \right)}$ mm</p> <p>(b) $t = \frac{d_p}{40}$ mm</p> <p>but not to be less than</p> <p>(c) $t = 5,5$ mm where $L < 90$ m, or $= 7,5$ mm where $L \geq 90$ m</p>
<p>r = least radius of gyration of pillar cross-section, in mm, and may be taken as: $= r = 10 \sqrt{\frac{I}{A_p}}$ mm</p> <p>A_p = cross-sectional area of pillar, in cm^2</p> <p><i>C, S as defined in Pt 4, Ch 1, 1.5 Symbols and definitions 1.5.1</i></p> <p><i>H_g as defined in Table 1.4.6 Deck girders, transverses and hatch beams</i></p> <p>I = least moment of inertia of cross-section, in cm^4</p>	<p>(3) Minimum wall thickness of hollow rectangular pillars or web plate thickness of I or channel sections</p>	<p>The lesser of (b) and (c) and not to be less than (a):</p> <p>(a) $t = \frac{P}{b \left(0,5 - 1,95 \frac{l_e}{r} \right)}$ mm</p> <p>(a) $t = \frac{P}{b \left(0,05 - 0,2 \frac{l_e}{r} \right)}$ mm</p> <p>(b) $t = \frac{br}{600l_e}$ mm</p> <p>(c) $t = \frac{b}{55}$ mm</p> <p>but to be not less than</p> <p>$t = 5,5$ mm where $L < 90$ m, or $= 7,5$ mm where $L \geq 90$ m</p>

<p>P = load, in kN (tonne-f), supported by the pillar and is to be taken as</p> $\frac{9,81SHg^l p}{C} + P_a$ $\left(\frac{SHg^l p}{C} + p_a \right)$ <p>but not less than 19,62 kN (2 tonne-f)</p>	<p>(4) Minimum thickness of flanges of angle or channel sections</p>	<p>The lesser of the following:</p> <p>(a) $t_f = \frac{br}{200l_e}$ mm</p> <p>(b) $t_f = \frac{b}{18}$ mm</p>
<p>P_a = load, in kN (tonne-f), from pillar or pillars above (zero if no pillars over)</p>	<p>(5) Minimum thickness of flanges of built or rolled I sections</p>	<p>The lesser of the following:</p> <p>(a) $t_f = \frac{br}{400l_e}$ mm</p> <p>(b) $t_f = \frac{b}{36}$ mm</p>
<p>Note As a first approximation A_p may be taken as $\frac{\sqrt{kP}}{9,32} \left(\frac{\sqrt{kP}}{0,95} \right)$ and the radius of gyration estimated for a suitable section having this area.</p> <p>Note If the area calculated using this radius of gyration differs by more than 10 per cent from the first approximation, a further calculation using the radius of gyration corresponding to the mean area of the first and second approximation is to be made.</p>		

4.5.5 Openings in the strength deck outside the line of hatch openings having a stress concentration factor in excess of 2,4 will require edge reinforcements in the form of a spigot of adequate dimensions, but alternative arrangements will be considered. The area of any edge reinforcement which may be required is not to be taken into account in determining the required sectional area of compensation for the opening. Alternatively, the shape of the opening is to be such that a stress concentration factor of 2,4 is not exceeded. In this respect, reinforcement will not in general, be required in way of:

- (a) elliptical openings having their major axis fore and aft and a ratio of length to breadth not less than 2 to 1, or
- (b) openings of other shapes provided that it has been shown by suitable tests that the stress concentration factor does not exceed 2,4.

Table 1.4.8 Non-watertight pillar bulkheads

Parameter	Requirement	
	Ships with $L < 90$ m	Ships with $L \geq 90$ m
(1) Minimum thickness of bulkhead plating	5,5 mm in holds and 'tween decks	7,5 mm in holds 6,5 mm in 'tween decks
(2) Maximum stiffener spacing	1500 mm	1500 mm
(3) Minimum depth of stiffeners or corrugations	100 mm in holds	150 mm in holds
	75 mm in 'tween decks	100 mm in 'tween decks
(4) Cross-sectional area (including plating) for rolled, built or swedged stiffeners supporting beams, longitudinals, girders or transverses	(a) Where $\frac{s}{t} \leq 80$	$A = A_1$
	(b) Where $\frac{s}{t} \geq 120$	$A = A_2$
	(c) Where $80 < \frac{s}{t} < 120$	A is obtained by interpolation between A_1 and A_2
(5) Cross-sectional area (including plating) for symmetrical corrugation	(a) Where $\frac{b}{t_p} \leq \frac{750 \lambda l_e}{(\lambda + 0,25)r}$	$A = A_1$
	(b) Where $\frac{b}{t_p} > \frac{750 \lambda l_e}{(\lambda + 0,25)r}$	$A = A_2$

Symbols

d_w, t_p, b, c as defined in Pt 3, Ch 3, 3 Structural idealisation

r = radius of gyration, in mm, of stiffener and attached plating

$$= 10\sqrt{\frac{I}{A}} \text{ mm for rolled, built or swedged stiffeners}$$

$$= d_w\sqrt{\frac{3b+c}{12(b+c)}} \text{ mm for symmetrical corrugation}$$

I = moment of inertia, in cm^4 , of stiffener and attached plating

s = spacing of stiffeners, in mm

A = cross-sectional area, in cm^2 , of stiffener and attached plating

$$A_1 = \frac{P}{12,36 - 51,5\frac{e}{r}} \text{ cm}^2$$

$$= \left(A_1 = \frac{P}{1,26 - 5,25\frac{e}{r}} \text{ cm}^2 \right)$$

= As a first approximation A_1 may be taken as

$$= \frac{P}{9,32} \left(\frac{P}{0,95} \right)$$

$$A_2 = \frac{P}{4,9 - 14,7 \frac{e}{r}} \text{ cm}^2$$

$$= \left(A_2 = \frac{P}{0,5 - 1,5 \frac{e}{r}} \text{ cm}^2 \right)$$

= As a first approximation A_2 may be taken as

$$= \frac{P}{3,92} \left(\frac{P}{0,4} \right)$$

= P, I_e as defined in *Table 1.4.7 Pillars*

$$\lambda = \frac{b}{c}$$

4.5.6 Lower deck openings should be kept clear of main hatch corners and the areas of high stress, so far as possible. Compensation will not, in general, be required unless the total width of openings in any frame space, or between any two transverses, exceeds 15k per cent of the original effective plating width. The requirements of *Pt 4, Ch 1, 4.5 Deck openings 4.5.4* also apply to lower deck openings except that:

- the thickness of inserts, if required, for the second deck hatch corners is to be 2,5 mm greater than the deck thickness,
- inserts will not generally be required for hatch corners on third decks, platform decks and below, and
- reinforcement will not generally be required for circular openings, provided that the plate panels in which they are situated are otherwise adequately stiffened against compression and shear buckling.

4.5.7 All openings are to be adequately framed; attention is to be paid to structural continuity, and abrupt changes of shape, section or plate thickness are to be avoided. Arrangements in way of corners and openings are to be such as to minimise the creation of stress concentrations. Where a deck longitudinal is cut, compensation is to be arranged to ensure full continuity of strength.

Table 1.4.9 Cantilever beams

Location and supporting arrangements	Required modulus, in cm ³ , see Notes	
	Cantilever beam	Supporting frame
(1) Any position - no support from end girders	$Z_o = 8,67k M_o (Z_o = 85k M_o)$	$Z_v = \frac{v}{H_1} \left(\frac{fZ_o}{u} - kZ_t \right)$
(2) At hatch side - uniform loading, partial support received from hatch side girder, see Figure 1.4.3 Section moduli of hatch end beams :		
(a) Hatch side girder supported by Rule hatch end beams or pillars at hatch corners	$Z_u = 0,9Z_o - kG$	$Z_v = \frac{v}{H_1} \left(\frac{fZ_u}{u} - kZ_t \right)$
(b) Hatch side girder supported by end bulkheads of hold - no Rule hatch end beams or pillars	Z_u as in (a) or the following formula, whichever is the greater: $\left(\frac{n+1}{n} \right) \left(0,45 \left(1 + \frac{1}{\beta} \right) Z_o - k\beta G - (1-\beta)kE \right)$	
(c) No transverse bulkheads between hatchways, no Rule hatch end beams or pillars, see Notes	Z_u as in (a) or the following formula, whichever is the greater: $\left(\frac{n+1}{n} \right) \left(\frac{Z_o}{\beta} - 0,5kE \right)$	
(d) At hatch side - concentrated loading	Z_u as in (a), (b) or (c), whichever is applicable, or as the following formula, whichever is the greater: $Z_o - kG_1$	
Case (1) or (2)	Required inertia, in cm ⁴	
	$I_u = \frac{9u}{k} Z_u$	—
<p>Note 1. Where a transverse bulkhead is fitted at only one end of a hatchway the section modulus of cantilever beams is to be a mean of the values obtained from (2)(b) and (2)(c).</p> <p>Note 2. Where only cantilevers in the length of a hatchway consist of two or three close together at the mid-length of hatchway, their modulus is to be determined by calculating the modulus of a single cantilever at mid-length and dividing this by the actual number of cantilevers.</p> <p>Note 3. If a negative value is obtained for the required section modulus, cantilevers are not necessary for the arrangement considered.</p> <p>Note 4. In calculating the actual section modulus of a cantilever or supporting frame, the effective area of attached plating is to be as given in Pt 3, Ch 3, 3 <i>Structural idealisation</i>. Intermediate beams or frames within the effective breadth may be included in the calculation.</p> <p>Note 5. Rule hatch end beams are those with scantlings determined from Table 1.4.6, assuming that the hatch side girder has a span between hatch end beams.</p> <p>Note 6. The section modulus of cantilever beams is to be not less than that determined from Table 1.4.5 <i>Strength/weather, cargo and accommodation deck beams</i> for beams in the same position.</p> <p>Note 7. The section modulus of side frames, pillars or pillar bulkhead stiffeners supporting cantilevers is to be not less than that required for ordinary side frames, pillars or pillar bulkhead stiffeners, as determined from the appropriate Sections of the Rules.</p>		

Note 8. The scantlings of the cantilever bracket within the shaded area shown in *Figure 1.4.2 Deck cantilevers* are to be as follows:

(a) Where tripping brackets are not fitted:

$$t = (0,0075d_c + 5)\sqrt{k} \text{ mm}$$

$$A_f = \left(\frac{27Z_d}{e} \left(1 - \frac{e}{1420f} \right) - \frac{et}{300} \right) k \text{ cm}^2$$

(b) Where tripping brackets are fitted at the positions indicated in *Figure 1.4.2 Deck cantilevers*:

$$t = (0,0075d_c + 5)\sqrt{k} \text{ mm}$$

$$A_f = \left(\frac{20Z_d}{e} \left(1 - \frac{e}{1420f} \right) - \frac{et}{200} \right) k \text{ cm}^2$$

In general the radius at the throat of the cantilever bracket is to be not less than d_c .

Note 9. The cantilever beam and supporting frame face plates may be gradually tapered from the limits of the shaded area shown in *Figure 1.4.2 Deck cantilevers*. The web depth of the supporting frame may be tapered to a minimum of $0,5d_f$ at the base.

Note 10. Where the web thickness of cantilevers or supporting frames is less than $\frac{d_w}{60\sqrt{k}}$ transverse web stiffeners are to be fitted spaced approximately $1,5d_w$ apart. In no case is the web thickness outside the limits of the cantilever brackets to be less than $\frac{d_w}{85\sqrt{k}}$

Where stiffeners are fitted parallel to the face plates, the stiffening arrangements will be specially considered.

Symbols

f = overall length of cantilever, in metres

Where there is no centreline support:

k = higher tensile steel factor as defined in Pt 4, Ch 1, 1.5 Symbols and definitions 1.5.1

d_c = web depth of cantilever, at root of bracket, in mm, see *Figure 1.4.2 Deck cantilevers*

l_b = distance, in metres, between transverse bulkheads, see *Figure 1.4.4 Deck supporting structure*. Where there is no bulkhead midway between hatchways, l_b is to be measured to a point midway between hatchways

d_f = web depth of frame at root of bracket, in mm, see *Figure 1.4.2 Deck cantilevers*

l_h = length of hatchway, in metres, see *Figure 1.4.4 Deck supporting structure*

d_w = web depth of cantilever or frame, in mm

C = cargo stowage rate in m^3/tonne as defined in Pt 3, Ch 3, 5 Design loading, and is to be taken as $1,39 \text{ m}^3/\text{tonne}$ unless specified otherwise

e = web depth, in mm, as shown in *Figure 1.4.2 Deck cantilevers*

Z_a = section modulus, in cm^3 , of hatch side girder which is to be not less than that calculated from *Table 1.4.6 Deck girders, transverses and hatch beams*, taking the span between cantilevers

Z_b = mean of section moduli, in cm^3 , of longitudinal girders in line with hatch side girder (Z_b is to be taken not greater than Z_a)

$$Z_d = \frac{fZ_u}{u}$$

Z_o = section modulus, in cm^3 , of cantilever beam, not supported by end girder, at distance u from outer end

Z_t = section modulus, in cm^3 , of frame or stiffener above cantilever, see *Figure 1.4.2 Deck cantilevers*. (Where there is no frame or stiffener above cantilever $Z_t = 0$)

Z_u = section modulus, in cm^3 , of cantilever beam, partially supported by hatch side girder at end, at distance u from outer end

Z_v = section modulus, in cm^3 , of supporting frame, at distance v from lower end

Z_1, Z_2, Z_3 = mean of section moduli, in cm^3 , of hatch end beams calculated for the positions shown in *Figure 1.4.3 Section moduli of hatch end beams*. Z_2 is to be taken as the smaller modulus of the two sections adjacent to the hatch side

$$\beta = \frac{l_h}{l_b}$$

n = number of cantilevers between the hatch end beams

t = thickness of cantilever bracket, in mm

u, v = lever arms, in metres, as shown in *Figure 1.4.2 Deck cantilevers*

A_f = sectional area, in cm^2 , of cantilever bracket face plate

B_h = breadth of hatch, in metres, see *Figure 1.4.4 Deck supporting structure*

$$E = \frac{4}{n+1} (Z_1 + Z_2)$$

$$G = \frac{7u}{(n+1)l_h} (Z_a + Z_b)$$

$$G_1 = \frac{3,5uZ_a}{S_c}$$

H_1, H_2, H_3 = mean height of hold or 'tween decks, in metres, as shown in *Figure 1.4.2 Deck cantilevers*. At weather decks, H_2 and H_3 are to be taken equivalent to the weather head h_1 as defined in *Pt 3, Ch 3, 5 Design loading*

E is determined as follows:

When centreline bulkheads or pillars are fitted:

$$E = \frac{4}{n+1} \left((Z_1 + Z_2) + \frac{2u}{B_h} (Z_2 + Z_3) \right)$$

M_o = bending moment, in kN m (tonne-f m), on the cantilever beam due to the load supported by a single cantilever. This bending moment is to be calculated about an axis at a distance u from the end. For hatch side cantilevers with uniformly distributed loading this will equal

$$= \frac{4,9S_c u}{c} (H_2 B_h + H_3 u)$$

$$= \left(\frac{0,5S_c u}{c} (H_2 B_h + H_3 u) \right)$$

S_c = spacing of cantilevers, in metres, see Figure 1.4.4 Deck supporting structure

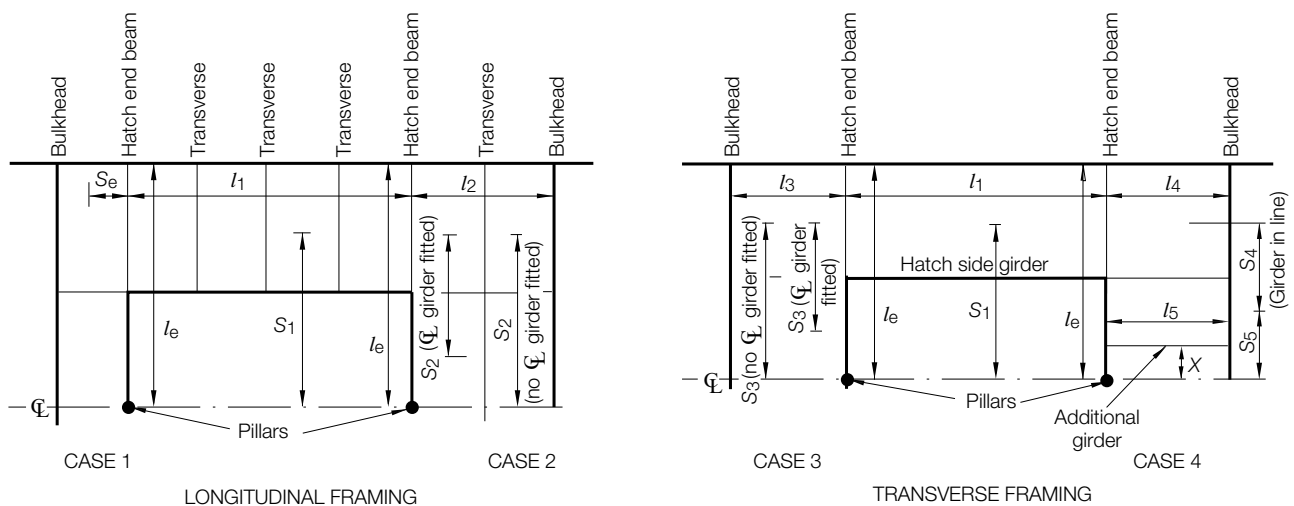
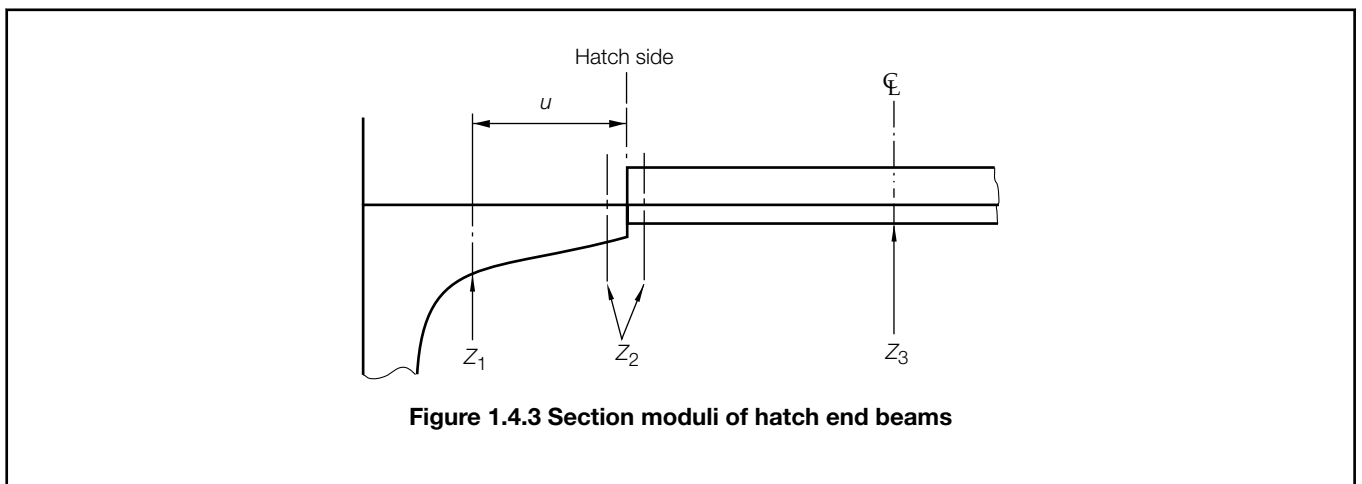
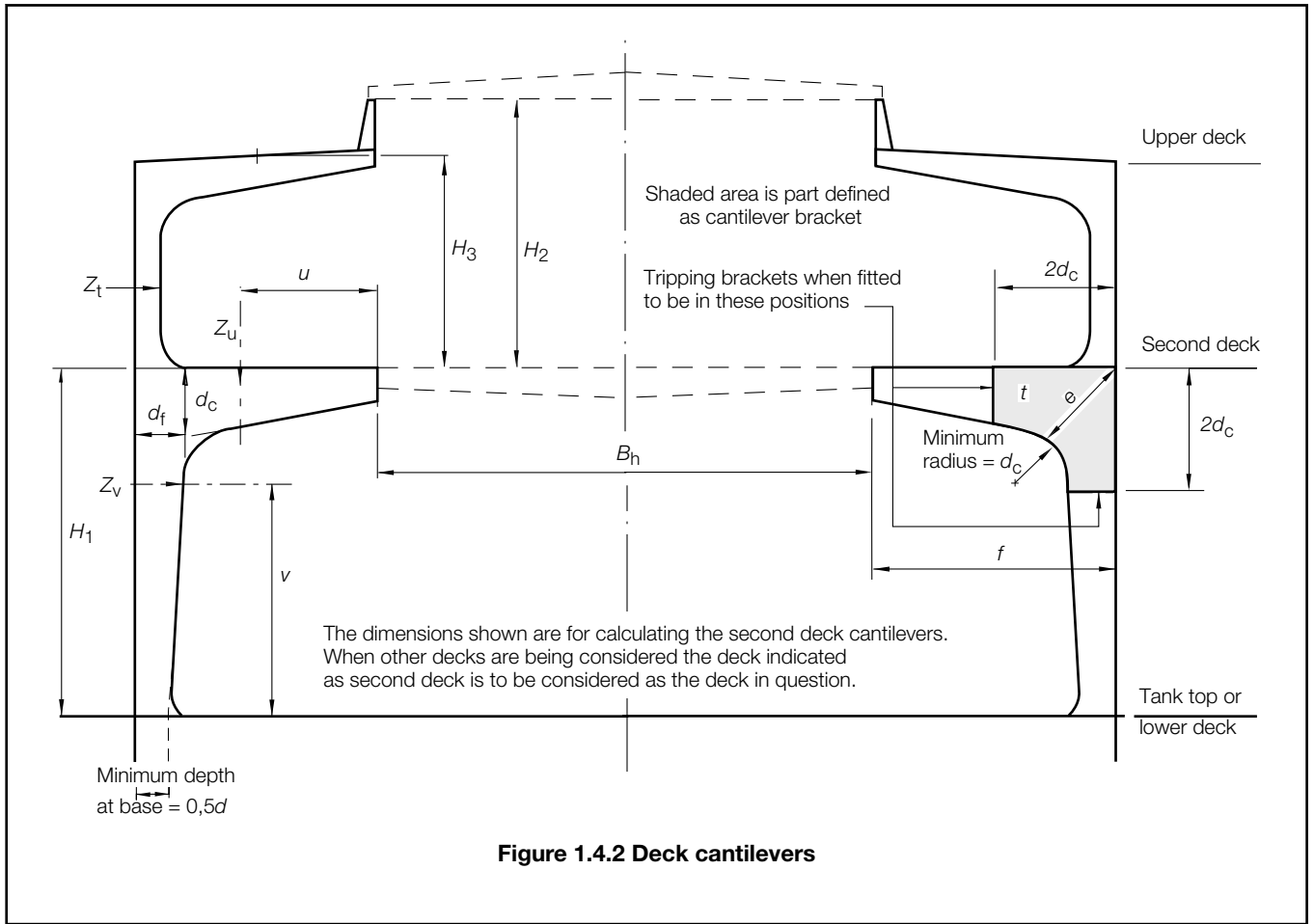

Figure 1.4.1 Hatch end beam arrangements



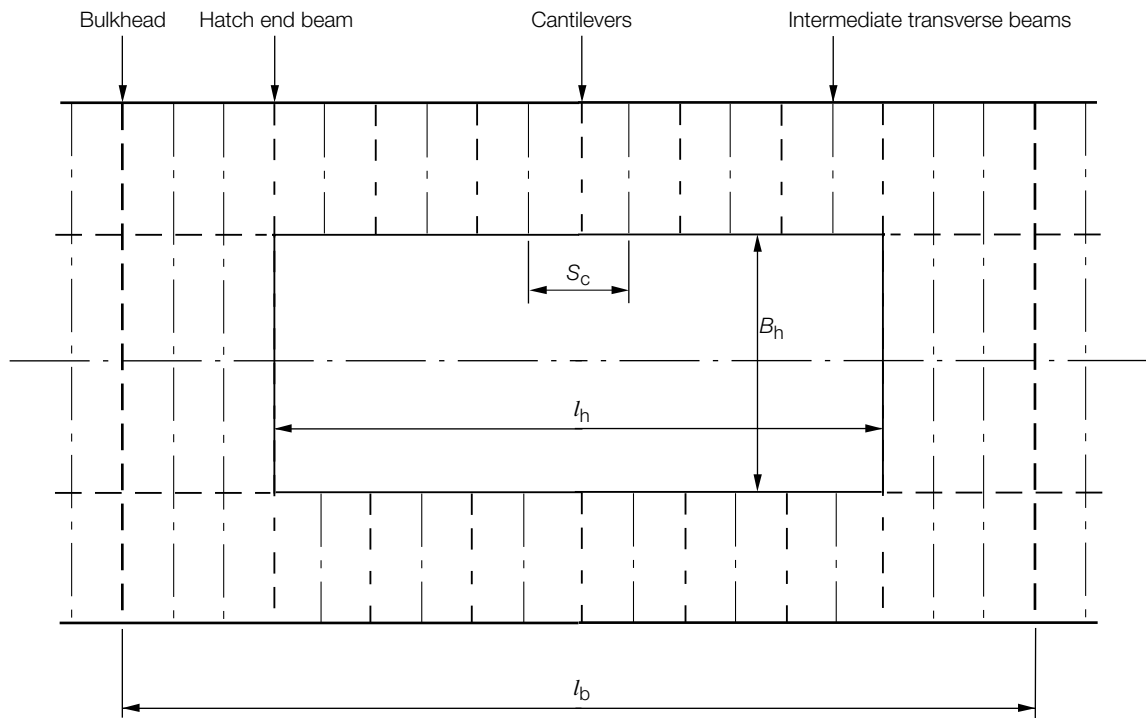

Figure 1.4.4 Deck supporting structure

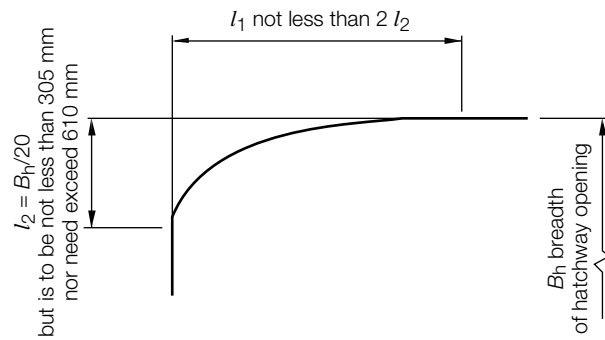

Figure 1.4.5 Elliptical and parabolic corners

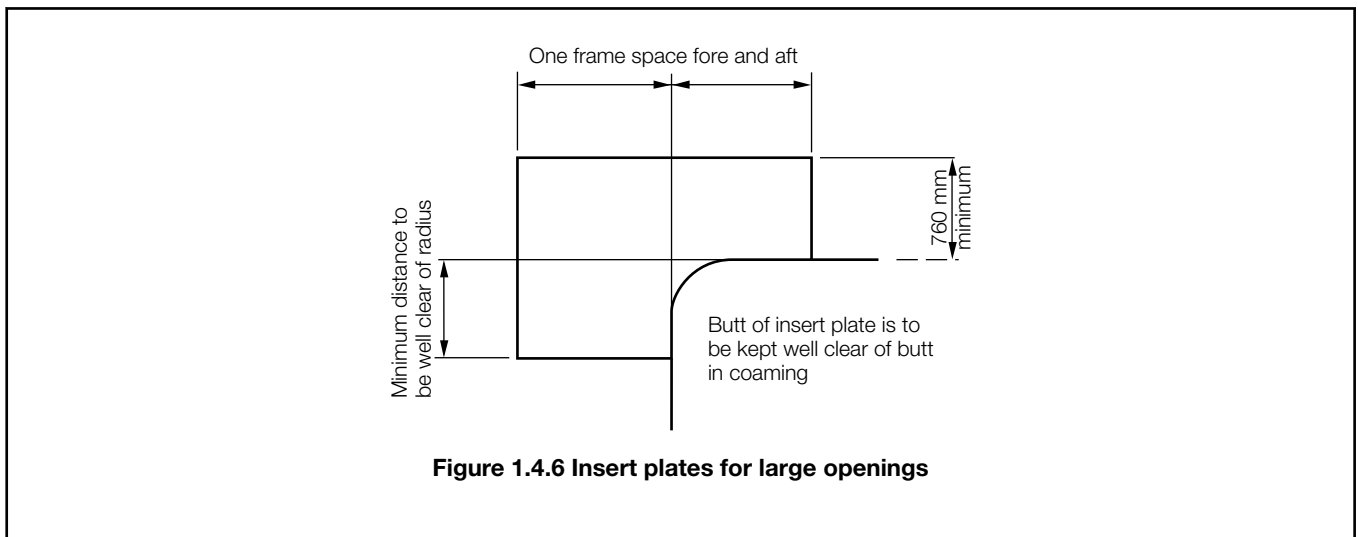

Figure 1.4.6 Insert plates for large openings

■ **Section 5**
Shell envelope plating

5.1 General

5.1.1 Requirements are given in this Section for longitudinal or transversely framed shell plating, and attention is drawn to the requirements of *Pt 4, Ch 1, 6.1 General 6.1.1*. In ships with a transversely framed bottom construction, the bottom shell plating is, in general, to be reinforced with additional continuous, or intercostal, longitudinal stiffeners, see also *Pt 4, Ch 1, 7.1 General 7.1.2*. Alternative arrangements will be considered.

5.1.2 For ships intended to load or unload while aground, see *Pt 3, Ch 9, 7 Bottom strengthening for loading and unloading aground*.

5.2 Keel

5.2.1 The cross-sectional area and thickness of bar keels, and the width and thickness of plate keels, are to comply with the requirements of *Table 1.5.1 Bar and plate keels*. Forged or rolled bar keels are also to comply with the material requirements of *Ch 3 Rolled Steel Plates, Strip, Sections and Bars of the Rules for the Manufacture, Testing and Certification of Materials* (hereinafter referred to as the Rules for Materials).

Table 1.5.1 Bar and plate keels

Item and parameter	Requirement
(1) Bar keels:	
Cross-sectional area	$A = (1,8L - 16) \text{ cm}^2$
Thickness	$t = (0,6L + 8) \text{ mm}$
(2) Plate keels:	
Breadth	$b = 70B \text{ mm}$ but need not exceed 1800 mm and is not to be less than 750 mm

Thickness	$t = (t_1 + 2)$ mm where t_1 is as in location (1) in Table 1.5.2, using the spacing in way of the keel plate t is to be taken not less than the adjacent bottom shell thickness
Symbols	
L, B as defined in Pt 4, Ch 1, 1.5 Symbols and definitions 1.5.1 b = breadth of keel, in mm t = thickness of keel, in mm A = cross-sectional area, in cm ²	

5.3 Bottom shell and bilge

5.3.1 In the midship region the thickness of bottom shell plating to the upper turn of bilge is to be that necessary to give the hull section modulus required by Pt 3, Ch 4, 5 Hull bending strength, and is to be not less than the minimum values given by Table 1.5.2 Bottom shell and bilge plating.

5.4 Side shell

5.4.1 In the midship region, the thickness of side shell and sheerstrake plating including the sides of bridge superstructures is to be not less than the values given by Table 1.5.3 Side shell plating, but may be required to be increased locally on account of high shear forces in accordance with Pt 3, Ch 4, 6 Hull shear strength.

5.4.2 Sea inlets, or other openings, are to have well rounded corners and so far as possible, are to be kept clear of the bilge radius. Openings on, or near to, the bilge radius are to be elliptical. The thickness of sea inlet box plating is to be the same as the adjacent shell, but not less than 12,5 mm and need not exceed 25 mm.

5.4.3 Where a rounded sheerstrake is adopted the radius should, in general, be not less than 15 times the thickness.

5.4.4 The sheerstrake thickness is to be increased by 20 per cent at the ends of a bridge superstructure extending out to the ship's side. In the case of a bridge superstructure exceeding 0,15L, the side plating at the ends of the superstructure is also to be increased by 25 per cent and tapered gradually into the upper deck sheerstrake.

5.4.5 In general, compensation will not be required for holes in the sheerstrake which are clear of the gunwale or any deck openings situated outside the line of the main hatchways and whose depth does not exceed 20 per cent of the depth of the sheerstrake or 380 mm, whichever is the lesser. Openings are not to be cut in a rounded gunwale. Cargo door openings are to have well rounded corners, and the proposed compensation for the door openings will be individually considered.

Table 1.5.2 Bottom shell and bilge plating

Location	Minimum thickness, in mm, see also Pt 4, Ch 1, 5.3 Bottom shell and bilge 5.3.1	
	Longitudinal framing	Transverse framing
(1) Bottom plating, see Notes 1 and 2	The greater of the following: (a) $t = 0,001s_1(0,043L_1 + 10)\sqrt{\frac{F_B}{k_L}}$ (see Note 4) (b) $t = 0,0052s_1\sqrt{\frac{h_{T2}k}{1,8 - F_B}}$	The greater of the following: (a) $t = 0,001s_1f_1(0,056L_1 + 16,7)\sqrt{\frac{F_B}{k_L}}$ (see Note 4) (b) $t = 0,0063s_1\sqrt{\frac{h_{T2}k}{1,8 - F_B}}$
(2) Bilge plating - where framed, see Notes 1 and 2	t as for (1)	t as for (1)

<p>(3) Bilge plating - where unframed, see Note 3</p>	<p>Provided that transverses or adequate bilge brackets are spaced not more than</p> $\frac{8t^2}{DR_B} \sqrt{\frac{t}{R_B}} \times 10^6 \text{ mm apart}$ <p>$t = \frac{R_B F_B}{165k_L}$ but is to be not less than the adjacent bottom plating</p>
<p>Symbols</p>	
<p>L, D, T, s, S, k_L, k as defined in Pt 4, Ch 1, 1.5 Symbols and definitions 1.5.1</p> <p>C_w is as defined in Pt 4, Ch 1, 1.5 Symbols and definitions 1.5.1.</p> <p>Where</p> <p>$L > 227 \text{ m}$, C_w is not to be taken less than 6,446 m</p> $f_1 = \frac{1}{1 + \left(\frac{s}{1000S}\right)^2}$ <p>$h_{T2} = (T + 0,5 C_w)$, in metres but need not be taken greater than 1,2T m</p> <p>$s_1 = s$, but is not to be taken less than the smaller of</p> $470 + \frac{L}{0,6} \text{ mm or } 700 \text{ mm}$ <p>$F_B =$ as defined in Pt 3, Ch 4, 5.7 Local reduction factors</p> <p>$L_1 = L$ but need not be taken greater than 190 m</p> <p>$R_B =$ bilge radius, in mm, see Note 3</p>	
<p>Note 1. The thickness derived in accordance with (1) is also to satisfy the buckling requirements of Pt 3, Ch 4, 7 Hull buckling strength.</p> <p>Note 2. The thickness of bottom shell or bilge plating is to be not less than the basic shell end thickness for taper as given in Pt 3, Ch 5, 3 Shell envelope plating and Pt 3, Ch 6, 3 Shell envelope plating.</p> <p>Note 3. Where longitudinally framed and the lowest side longitudinal lies a distance a mm above the uppermost turn of bilge and/or the outermost bottom longitudinal lies a distance b inboard of the lower turn of bilge, the bilge radius is to be taken as $R_B + \frac{(a+b)}{2}$ mm. In no case is a or b to be greater than s.</p> <p>Note 4. Where separate maximum sagging and hogging still water bending moments are assigned, F_B may be based on the hogging moment.</p>	

Table 1.5.3 Side shell plating

<p>Location</p>	<p>Thickness, in mm, see also Pt 4, Ch 1, 5.4 Side shell 5.4.1</p>	
	<p>Longitudinal framing</p>	<p>Transverse framing</p>

(1) Side shell clear of sheerstrake, see Notes 1, 2, 4 and 5	(a) Above $\frac{D}{2}$ from base: The greater of the following: (i) $t = 0,001s_1(0,059L_1 + 7)\sqrt{\frac{F_D}{k_L}}$ (ii) $t = 0,0042s_1\sqrt{h_{T1}k}$	(a) Within $\frac{D}{4}$ from the gunwale: The greater of the following: (i) $t = 0,00085s_1f_1(0,083L_1 + 10)\sqrt{\frac{F_D}{k_L}}$ (ii) $t = 0,0042s_1\sqrt{h_{T1}k}$
	(b) At upper turn of bilge, see Note 3: The greater of the following: (i) $t = 0,001s_1(0,059L_1 + 7)\sqrt{\frac{F_M}{k_L}}$ (ii) $t = 0,0054s_1\sqrt{\frac{h_{T2}k}{2 - F_B}}$	(b) Within $\frac{D}{4}$ from mid-depth: The greater of the following: (i) $t = 0,001s_1(0,059L_1 + 7)\sqrt{\frac{F_M}{k_L}}$ (ii) $t = 0,0051s_1\sqrt{h_{T1}k}$
	(c) Between upper turn of bilge and $\frac{D}{2}$ from base: The greater of the following: (i) t from (b)(i) (ii) t from interpolation between (a)(ii) and (b)(ii)	(c) Within $\frac{D}{4}$ from base (excluding bilge plating) see Note 3: The greater of the following: (i) $t = 0,00085s_1f_1(0,083L_1 + 10)\sqrt{\frac{F_B}{k_L}}$ (ii) $t = 0,0056s_1\sqrt{\frac{h_{T2}k}{1,8 - F_B}}$
(2) Sheerstrake, see Notes 1, 2 and 5	The greater of the following: (i) $t = 0,001s_1(0,059L_1 + 7)\sqrt{\frac{F_D}{k_L}}$ (ii) $t = 0,00083s_1\sqrt{Lk} + 2,5$ but t is to be not less than the thickness of the adjacent side plating	The greater of the following: (i) $t = 0,001s_1f_1(0,083L_1 + 10)\sqrt{\frac{F_D}{k_L}}$ (ii) $t = 0,001s_1\sqrt{Lk} + 2,5$ but t is to be not less than the thickness of the adjacent side plating

Symbols

L, D, T, S, s, k_L, k , as defined in Pt 4, Ch 1, 1.5 Symbols and definitions 1.5.1

C_w is as defined in Pt 4, Ch 1, 1.5 Symbols and definitions 1.5.1.

Where $L > 227$ m, C_w is not to be taken less than 6,446 m

$$f_1 = \frac{1}{1 + \left(\frac{s}{1000S}\right)^2}$$

$$h_{T1} = T + C_w \text{ m but need not be taken greater than } 1,36T$$

$$h_{T2} = T + 0,5C_w \text{ m but need not be taken greater than } 1,2T$$

$s_1 = s$, but is not to be taken less than the smaller of

$$470 + \frac{L}{0,6} \text{ mm or } 700 \text{ mm}$$

F_D, F_B = as defined in Pt 3, Ch 4, 5.7 Local reduction factors

F_M = the greater of F_D or F_B

L_1 = L , but need not be taken greater than 190 m

Note 1. The thickness is also to satisfy the buckling requirements of Pt 3, Ch 4, 7 Hull buckling strength.

Note 2. The thickness of side shell or sheerstrake is to be not less than the basic shell end thickness for taper, as given in Pt 3, Ch 5, 3 Shell envelope plating and Pt 3, Ch 6, 3 Shell envelope plating. The width of the sheerstrake (where of different thickness from the side shell) is to be not less than that required by Table 2.2.1 Material classes and grades in Pt 3, Ch 2 Materials.

Note 3. The thickness of side shell need not exceed that determined from Table 1.5.2 Bottom shell and bilge plating for bottom shell, but using the spacing of side frames or longitudinals.

Note 4. Outside the Rule minimum region of higher tensile steel as defined in Pt 3, Ch 3, 2.6 Vertical extent of higher tensile steel 2.6.1 the value of k_L may be taken as 1,0.

Note 5. For the expressions contained in (i), where separate maximum sagging and hogging still water bending moments are assigned, F_D may be based on the sagging moment and F_B on the hogging moment.

■ Section 6 Shell envelope framing

6.1 General

6.1.1 Longitudinal framing is, in general, to be adopted at the bottom, but special consideration will be given to proposals for transverse framing in this region. Transverse or longitudinal framing can be adopted for the side shell. Requirements are given in this Section for longitudinal and transverse framing systems.

6.1.2 End connections of longitudinals to bulkheads are to provide adequate fixity and, so far as practicable, direct continuity of longitudinal strength. Where L exceeds 215 m, the bottom longitudinals are to be continuous in way of both watertight and non-watertight floors, but alternative arrangements will be considered. Higher tensile steel longitudinals within 10 per cent of the ship's depth at the bottom and deck are to be continuous irrespective of the ship length, see also Pt 3, Ch 10, 5.2 Arrangements at intersections of continuous secondary and primary members.

6.1.3 Stiffeners and brackets on side transverses, where fitted on one side and connected to higher tensile steel longitudinals between the base line and $0,8D_2$ above the base line, are to have their heels well radiused to reduce stress concentrations. Where a symmetrical arrangement is fitted, i.e. bracket or stiffening on both sides, and it is connected to higher tensile steel longitudinals, the toes of the stiffeners or brackets are to be well radiused. Alternative arrangements will be considered if supported by appropriate direct calculations, see also Pt 3, Ch 10, 5.2 Arrangements at intersections of continuous secondary and primary members.

6.1.4 Where higher tensile steel side longitudinals pass through transverse bulkheads in the cargo area, well radiused brackets of the same material are to be fitted on both the fore and aft side of the connection between the upper turn of bilge and $0,8D_2$ above the base line. Particular attention should be given to ensuring the alignment of these brackets. Alternative arrangements will be considered if supported by appropriate direct calculations, see also Pt 4, Ch 1, 6.2 Longitudinal stiffening 6.2.3.

6.1.5 For ships intended to load or unload while aground, see Pt 3, Ch 9, 7 Bottom strengthening for loading and unloading aground.

6.2 Longitudinal stiffening

6.2.1 For non-CSR tankers, bulk carriers and ore carriers (see Pt 1, Ch 2, 2.3 Class notations (hull)) the scantlings of bottom and side longitudinals in the midship region are to comply with the requirements given in Table 1.6.2 (b) Shell framing (longitudinal). In general other ships are to comply with Table 1.6.1 (a) Shell framing (longitudinal).

6.2.2 The lateral and torsional stability of longitudinals together with web and flange buckling criteria are to be verified in accordance with *Pt 3, Ch 4, 7 Hull buckling strength*.

6.2.3 Where higher tensile steel asymmetrical sections are adopted in double bottom tanks which are interconnected with double skin side tanks or combined hopper and topside tanks the requirements of *Pt 4, Ch 1, 6.1 General 6.1.3* and *Pt 4, Ch 1, 6.1 General 6.1.4* are to be complied with regarding arrangements to reduce stress concentrations. Alternatively, it is recommended that bulb plate or symmetrical sections are adopted.

6.3 Transverse stiffening

6.3.1 The scantlings of main and 'tween deck frames, and bottom frames in way of bracket floors, in the midship region are to comply with the requirements given in *Table 1.6.3 Shell framing (transverse)*.

6.3.2 The scantlings of main frames are normally to be based on Rule standard brackets at top and bottom, whilst the scantlings of 'tween deck frames are normally to be based on a Rule standard bracket at the top only.

6.3.3 End connections of transverse main and 'tween deck frames are to be in accordance with *Pt 3, Ch 10, 3 Secondary member end connections*.

6.4 Primary supporting structure

6.4.1 Side transverses supporting longitudinal stiffening, and webs and stringers supporting transverse side stiffening, are to comply with the requirements of *Table 1.6.4 Primary structure*.

6.4.2 Side transverses are to be spaced not more than 3,8 m apart when the length, L , is less than 100 m and $(0,006L + 3,2)$ m apart where L is greater than 100 m.

Table 1.6.1 (a) Shell framing (longitudinal)

Location	Modulus, in cm ³
(1) Side longitudinals in way of dry spaces, including double skin construction, see Note 2	The lesser of the following: (a) $Z = 0,056skh_{T1}l_e^2F_1F_S$ (b) Z from (3)(a) evaluated using s, k and l_e for the longitudinal under consideration and the remaining parameters evaluated at the base line
(2) Side longitudinals in way of double skin tanks or deep tanks, see Note 2	The greater of the following: (a) Z as from (1) (b) As required by Ch1, 9 for deep tanks
(3) Bottom and bilge longitudinals, see Notes 1, 2, 3 and 4	The greater of the following: $Z = yskh_{T2}l_e^2F_1$ $Z = yskh_{T3}l_e^2F_1F_{sb}$
Symbols	
<p>L, D, T, s, k, k_L, ρ, as defined in Pt 4, Ch 1, 1.5 Symbols and definitions 1.5.1</p> <p>l_e = as defined in Pt 4, Ch 1, 1.5 Symbols and definitions 1.5.1, but is not to be taken less than 1,5 m except in way of the centre girder brackets required by Pt 4, Ch 1, 8.5 Floors 8.5.3 where a minimum span of 1,25 m may be used</p> <p>$l_{e1} = l_e$ in metres, but is not to be taken less than 2,5 m and need not be taken greater than 5,0 m</p> <p>$c_1 = \frac{60}{225 - 165F}$ at deck</p> <p>= 1,0 at $\frac{D_2}{2}$</p> <p>= $\frac{75}{225 - 150F_B}$ at baseline</p> <p>C_1 intermediate values by interpolation</p> <p>$D_1 = D_2$, in metres, but is not to be taken less than 10 and need not be taken greater than 16</p> <p>$D_2 = D$, in metres, but need not be taken greater than 1,6T</p> <p>F_B, F_D as defined in Pt 3, Ch 4, 5.7 Local reduction factors</p> <p>$F_1 = \frac{D_2 c_1}{4D_2 + 20h_5}$ for side longitudinals above $\frac{D_2}{2}$</p> <p>= $\frac{D_2 c_1}{25D_2 + 20h_5}$</p> <p>Minimum $F_1 = 0,14$</p> <p>for side longitudinals below $\frac{D_2}{2}$ and bottom longitudinals</p>	

$L_1 = L$ but need not be taken greater than 190 m

F_s is a fatigue factor for side longitudinals to be taken as follows:

(a) For built sections and rolled angle bars

$$F_s = \frac{1,1}{k} \left[1 - \frac{2b_{f1}}{b_f} (1 - k) \right] \text{ at } 0,6D_2 \text{ above the base line}$$

= 1,0 at D_2 and above, and F_{sb} at the base line intermediate values by linear interpolation

(b) For flat bars and bulb plates $\frac{b_{f1}}{b_f}$ may be taken as 0,5

F_{sb} is a fatigue factor for bottom longitudinals = 0,5 (1 + F_s at 0,6 D_2)

Where

b_{f1} = the minimum distance, in mm, from the edge of the face plate of the side longitudinal under consideration to the centre of the web plate, see Pt 4, Ch 9, 5.2 Symbols 5.2.1 in Chapter 9

$$h_{T1} = C_w \left(1 - \frac{h_6}{D_2 - T} \right) F_\lambda \text{ in metres, for longitudinals above the waterline, at draught } T, \text{ where } \left(1 - \frac{h_6}{D_2 - T} \right) \text{ is not to be taken less than } 0,7$$

$$= \left[h_6 + C_w \left(1 - \frac{h_6}{2T} \right) \right] F_\lambda, \text{ in metres, for longitudinals below the waterline at draught } T$$

h_{T1} and h_{T2} need not exceed $0,86\left(h_5 + \frac{D_1}{8}\right)$ for $F_1 \leq 0,14$ and $\left(h_5 + \frac{D_1}{8}\right)$ for $F_1 > 0,14$

$h_{T2} = (T + 0,5C_W) F_\lambda$, in metres for bottom longitudinals

$h_{T3} = h_4 - 0,25T$, in metres

h_4 = load head required by Pt 4, Ch 1, 9.1 General for deep tanks

h_5 = vertical distance, in metres, from longitudinal to deck at depth, D_2

h_6 = vertical distance, in metres, from the waterline at draught T to the longitudinal under consideration

b_f = the width of the face plate, in mm, of the side longitudinal under consideration, see Pt 4, Ch 9, 5.2 Symbols 5.2.1 in Chapter 9

C_W = a wave head, in metres = $7,71 \times 10^{-2} L e^{-0,0044L}$ where e = base of natural logarithms 2,7183

$F_\lambda = 1,0$ for $L \leq 200$ m

= $[1,0 + 0,0023(L - 200)]$ for $L > 200$ m

$\gamma = 0,002e_1 + 0,046$

NOTES

Note 1. The buckling requirements of Pt 3, Ch 4, 7 are to be complied with. The ratio of the web depth, d_w , to web thickness, t , is to comply with the following requirements:

(a) Built up profiles and rolled angles:

$$\frac{d_w}{t} \leq 60\sqrt{K_L}$$

b) Flat bars:

$$\frac{d_w}{t} \leq 18\sqrt{K_L} \text{ when continuous at bulkheads}$$

$$\frac{d_w}{t} \leq 15\sqrt{K_L} \text{ when non-continuous at bulkheads}$$

Note 2. Where struts are fitted midway between transverses in way of double bottom tanks, or double skin construction, the modulus of the bottom or side longitudinals may be reduced by 50k per cent from that obtained from the locations (1), (2), or (3) as applicable.

Note 3. Where the bilge radius exceeds the Rule height of a double bottom the modulus of the longitudinal above this nominal height is to be derived from the location (1) or (2) as applicable.

Note 4. Where no bilge longitudinals are fitted and bilge brackets are required by location (3) in Table 1.5.2, at least two brackets are to be fitted.

Table 1.6.2 (b) Shell framing (longitudinal)

Location	Modulus, in cm ³
(1) Side longitudinals in way of dry spaces, including double skin construction, see Note 2	The lesser of the following: (a) $Z = 0,056skh_{T1}l_e^2F_1F_S$ (b) Z from (3)(a) evaluated using s and l_e for the longitudinal under consideration and the remaining parameters evaluated at the base line
(2) Side longitudinals in way of double skin tanks or deep tanks, see Note 2	The greater of the following: (a) Z as from (1) As required by Pt 4, Ch 1, 9.1 General for deep tanks using h_{T3} instead of h_4 , but need not exceed Z from (3)(b) evaluated using γ , s and fige for the longitudinal under consideration and the remaining parameters evaluated at the base line

(3) Bottom and bilge longitudinals, see Notes 1, 2, 3 and 4	The greater of the following: $Z = yskh_{T2} l_e^2 F_1 F_{sb}$ $Z = yskh_{T3} l_e^2 F_1 F_{sb}$
Symbols	
<p>L, D, T, s, k, ρ, as defined in Pt 4, Ch 1, 1.5 Symbols and definitions 1.5.1</p> <p>l_e as defined in Pt 4, Ch 1, 1.5 Symbols and definitions 1.5.1, but is not to be taken less than 1,5 m except in way of the centre girder brackets required by Pt 4, Ch 1, 8.5 Floors 8.5.3 where a minimum span of 1,25 m may be used</p> <p>$l_{e1} = l_e$ in metres, but is not to be taken less than 2,5 m and need not be taken greater than 5,0 m</p> <p>$c_1 = \frac{60}{225 - 165F}$ at deck</p> <p>$= 1,0$ at $\frac{D_2}{2}$</p> <p>$= \frac{75}{225 - 150F_B}$ at baseline</p> <p>C1 intermediate values by interpolation</p> <p>$D_1 = D_2$, in metres, but is not to be taken less than 10 and need not be taken greater than 16</p> <p>$D_2 = D$, in metres, but need not be taken greater than 1,6T</p> <p>F_B, F_D as defined in Pt 3, Ch 4, 5.7 Local reduction factors</p> <p>$F_1 = \frac{D_2 c_1}{4D_2 + 20h_5}$ for side longitudinals above $\frac{D_2}{2}$</p> <p>$= \frac{D_2 c_1}{25D_2 + 20\lambda_5}$</p> <p>Minimum $F_1 = 0,14$</p> <p>for side longitudinals below $\frac{D_2}{2}$</p> <p>$L_1 = L$ but need not be taken greater than 190 m</p> <p>F_s is a fatigue factor for side longitudinals to be taken as follows:</p> <p>(a) For built sections and rolled angle bars</p> <p>$F_s = \frac{1,1}{k} \left[1 - \frac{2bf_1}{b_f} \left(1 - k \right) \right]$ at $0,6D_2$ above the base line</p> <p>$= 1,0$ at D_2 and above, and F_{sb} at the base line intermediate values by linear interpolation</p> <p>(b) For flat bars and bulb plates $\frac{bf_1}{b_f}$ may be taken as 0,5</p> <p>F_{sb} is a fatigue factor for bottom longitudinals $= 0,5 (1 + F_s$ at $0,6D_2)$</p>	

Where

b_{f1} = the minimum distance, in mm, from the edge of the face plate of the side longitudinal under consideration to the centre of the web plate, see Pt 4, Ch 9, 5.2 Symbols 5.2.1 in Chapter 9

$$h_{T1} = C_w \left(1 - \frac{h_6}{D_2 - T} \right) F_\lambda \text{ in metres, for longitudinals above the waterline, at draught } T, \text{ where } \left(1 - \frac{h_6}{D_2 - T} \right) \text{ is not to be taken less than } 0,7$$

$$= \left[h_6 + C_w \left(1 - \frac{h_6}{2T} \right) \right] F_\lambda, \text{ in metres, for longitudinals below the waterline at draught } T$$

$$h_{T1} \text{ and } h_{T2} \text{ need not exceed } 0,86 \left(h_5 + \frac{D_1}{8} \right) \text{ for } F_1 \leq 0,14 \text{ and } \left(h_5 + \frac{D_1}{8} \right) \text{ for } F_1 > 0,14$$

$$h_{T2} = (T + 0,5C_w) F_\lambda, \text{ in metres for bottom longitudinals}$$

$$h_{T3} = h_4 - 0,25T, \text{ in metres}$$

h_4 = load head required by Pt 4, Ch 1, 9.1 General for deep tanks

h_5 = vertical distance, in metres, from longitudinal to deck at depth, D_2

h_6 = vertical distance, in metres, from the waterline at draught T to the longitudinal under consideration

b_f = the width of the face plate, in mm, of the side longitudinal under consideration, see Pt 4, Ch 9, 5.2 Symbols 5.2.1 in Chapter 9

C_w = a wave head, in metres = $7,71 \times 10^{-2} L e^{-0,0044L}$ where e = base of natural logarithms 2,7183

$F_\lambda = 1,0$ for $L \leq 200$ m

= $[1,0 + 0,0023(L - 200)]$ for $L > 200$ m

$\gamma = 0,002/e_1 + 0,046$

NOTES

Note 1. The buckling requirements of Pt 3, Ch 4,7 are to be complied with. The ratio of the web depth, d_w , to web thickness, t , is to comply with the following requirements:

(a) Built up profiles and rolled angles:

$$\frac{d_w}{t} \leq 60\sqrt{K_L}$$

b) Flat bars:

$$\frac{d_w}{t} \leq 18\sqrt{K_L} \text{ when continuous at bulkheads}$$

$$\frac{d_w}{t} \leq 15\sqrt{K_L} \text{ when non-continuous at bulkheads}$$

Note 2. Where struts are fitted midway between transverses in way of double bottom tanks, or double skin construction, the modulus of the bottom or side longitudinals may be reduced by 50k per cent from that obtained from the locations (1), (2), or (3) as applicable.

Note 3. Where the bilge radius exceeds the Rule height of a double bottom the modulus of the longitudinal above this nominal height is to be derived from the location (1) or (2) as applicable.

Note 4. Where no bilge longitudinals are fitted and bilge brackets are required by location (3) in Table 1.5.2, at least two brackets are to be fitted.

Table 1.6.3 Shell framing (transverse)

Location	Modulus, in cm ³	Inertia, in cm ⁴
(1) Main, 'tween deck and superstructure frames in dry spaces, see Note 3	The greater of the following: (a) $Z = C s k h_{T1} H^2 \times 10^{-3}$ (b) $Z = 9,1 s k D_1 \times 10^{-3}$	$I = \frac{3,2}{k} H Z$
(2) Main and 'tween deck frames in way of fuel or water ballast tanks or cargo holds used for water ballast	The greater of the following: (a) $1,15 \times Z$ from (1) (b) $Z = 6,7 s k h H_2^2 \times 10^{-3}$	$I = \frac{3,2}{k} H Z$
(3) Frames supporting hatch end beams or deck transverses, see Note 2	The greater of the following: (a) Z from (1) (b) $Z = 2,5 (0,2 l_s^2 + H_1^2) k S_1 H_g$	$I = \frac{3,2}{k} H Z$
(4) Bottom frames of double bottom bracket floors	$Z = 2,15 s k T l_e \times 10^{-2}$	—
Symbols		
<p><i>D, T, s, k</i> as defined in Pt 4, Ch 1, 1.5 Symbols and definitions 1.5.1</p> <p>C = end connection factor = 3,4 where two Rule standard brackets are fitted = 3,4 (1,8 - 0,8 (l_a / l)) where one Rule standard bracket and one reduced bracket fitted = 3,4 (2,15 - 1,15 (l_{amean} / l)) where two reduced brackets are fitted = 6,1 where one Rule standard bracket is fitted = 6,1 (1,2 - 0,2 (l_a / l)) where one reduced bracket is fitted = 7,3 where no bracket is fitted</p> <p>The requirements for frames where brackets larger than Rule standard are fitted will be specially considered</p> <p>l_a = equivalent arm length, in mm, as derived from Pt 3, Ch 10, 3.4 Scantlings of end brackets 3.4.1</p> <p>l_{amean} = mean equivalent arm length, in mm, for both brackets</p> <p>h_{T1} = head, in metres, at middle of <i>H</i> = $C_w \left(1 - \frac{h_6}{D_1 - T} \right) F_{\lambda}$, in metres for frames where the mid-length of frame is above the waterline, at draught <i>T</i> where $\left(1 - \frac{h_6}{D_1 - T} \right)$ is not to be taken less than 0,7 = $[h_6 + C_w \left(1 - \frac{h_6}{2T} \right)] F_{\lambda}$, in metres for frames where the mid-length of frame is below the waterline at draught <i>T</i></p> <p>h = h_4 or h_5, whichever is the greater</p> <p>h_4 = tank head, in metres, as defined in Pt 3, Ch 3, 5 Design loading</p> <p>h_5 = head, in metres, measured from the mid-length of <i>H</i>, to the deck at side</p>		

h_6 = vertical distance in metres, from waterline at draught T to the mid-length of H

l_s = distance, in metres, from side shell to inboard support of beam or transverse

l_e = effective length, in metres, of bottom frames for double bottom bracket floors

l_h = length, in metres, of hatch side girder

C_w = a wave head, in metres,
 $= 7,71 \times 10^{-2} L e^{-0,0044L}$
 = where e = base of natural logarithm 2,7183

F_L = 1,0 for $L \leq 200$ m
 $= (1,0 + 0,0023 (L - 200))$ for $L > 200$ m

D_1 = D , but need not be taken greater than $1,6T$

H = H_{MF} or H_{TF} as applicable, see Note 1

H_{MF} = vertical framing depth, in metres, of main frames, as shown in *Figure 1.6.1 Framing depths for various structural configurations*, but is to be taken not less than 3,5 m

H_{TF} = vertical framing depth, in metres, of 'tween deck frames, as shown in *Figure 1.6.1 Framing depths for various structural configurations*, but is to be taken not less than 2,5 m

H_1 = H , but need not be taken greater than 3,5 m

H_2 = H , where H_{MF} is to be taken not less than 2,5 m

H_9 = weather head, h_1 , or cargo head, h_2 , in metres, as defined in *Pt 3, Ch 3, 5 Design loading*, whichever is applicable

S = spacing, in metres, of deck transverses

S_1 = $\frac{l_h}{4}$ for hatch end beams
 = S for transverses

Note 1. Where frames are inclined at more than 15° to the vertical, H_{MF} or H_{TF} is to be measured along a chord between span points of the frame.

Note 2. If the modulus obtained from (3) for frames under deck transverses exceeds that obtained from (1) and (2), the intermediate frames may be reduced provided that the combined modulus is maintained and the reduction in any intermediate frame is not greater than 35 per cent. The reduced modulus is to be not less than that given by (1)(b).

Note 3. The scantlings of main frames are not to be less than those of the 'tween deck frames above.

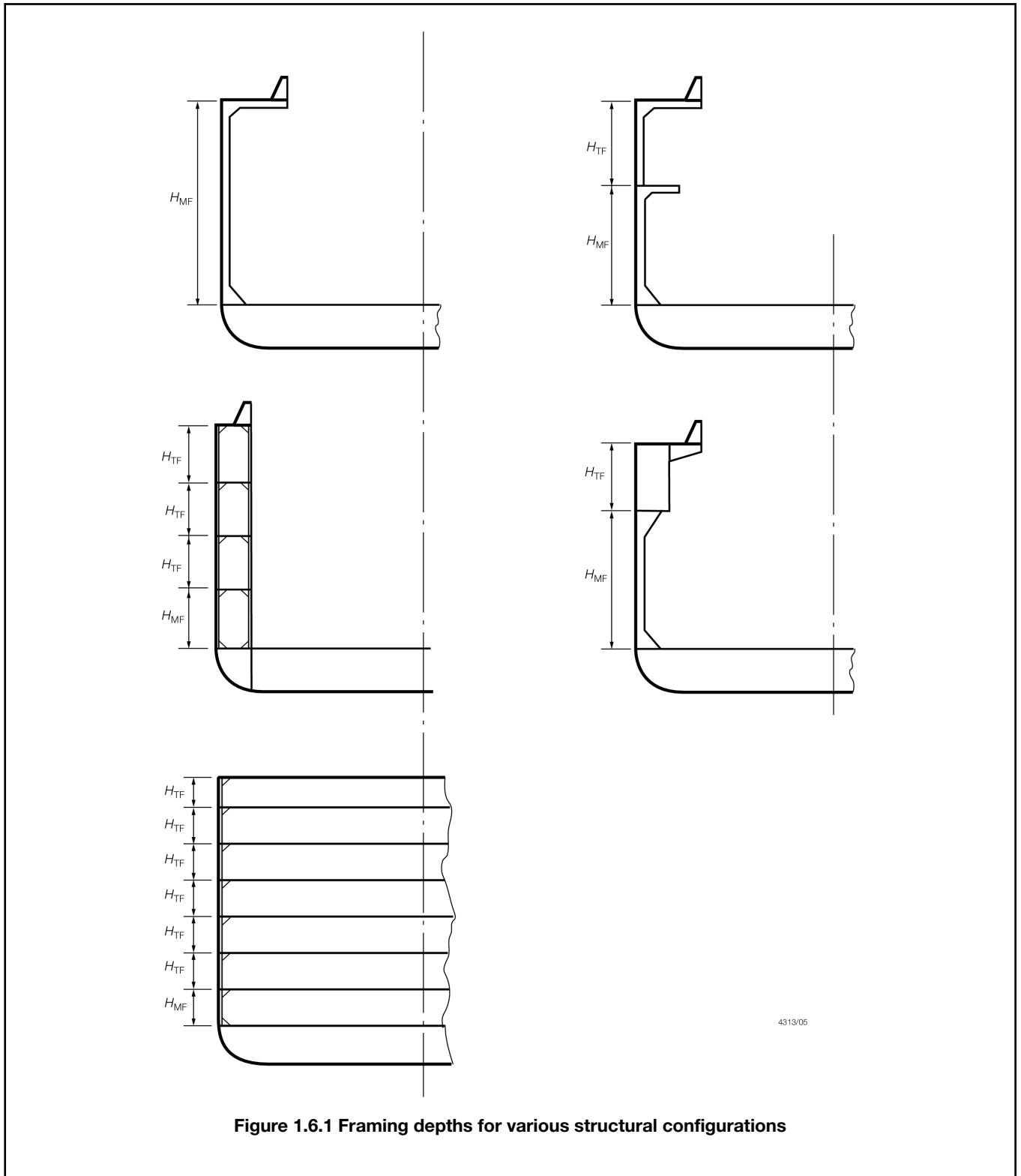

Figure 1.6.1 Framing depths for various structural configurations

Table 1.6.4 Primary structure

Item and location	Modulus, in cm ³	Inertia, in cm ⁴
Longitudinal framing system:		
(1) Side transverses in dry cargo spaces	$Z = 10k S h_{T1} l_e^2$	—
(2) Side transverses in deep tanks	$Z = 11,7\rho k S h_4 l_e^2$ or as (1) above, whichever is the greater	$I = \frac{2,5}{k} l_e Z$
Transverse framing system:		
(3) Side stringers in dry cargo spaces	$Z = 7,75 k S h_{T1} l_e^2$	—
(4) Side stringers in deep tanks	$Z = 11,7\rho k S h_4 l_e^2$ or as (3) above, whichever is the greater	$I = \frac{2,5}{k} l_e Z$
(5) Web frames supporting side stringers	Z determined from calculation based on following assumptions: (a) fixed ends (b) point loadings (c) head h_4 or h_{T1} as applicable (d) bending stress $\frac{93,2}{k} \text{ N/mm}^2 \left(\frac{9,5}{k} \text{ kgf/mm}^2 \right)$ (e) shear stress $\frac{83,4}{k} \text{ N/mm}^2 \left(\frac{8,5}{k} \text{ kgf/mm}^2 \right)$	$I = \frac{2,5}{k} l_e Z$
Symbols		
<p>T, S, l_e, k, ρ = as defined in Pt 4, Ch 1, 1.5 Symbols and definitions 1.5.1</p> <p>h_4 = tank head, in metres, as defined in Pt 3, Ch 3, 5 Design loading</p> <p>h_{T1} = head, in metres, at mid-length of span</p> <p>= $C_w \left(1 - \frac{h_6}{D_1 - T} \right) F_\lambda$, in metres where mid-length of span is above the waterline at draught T, where $\left(1 - \frac{h_6}{D_1 - T} \right)$ is not to be taken less than 0,7</p> <p>= $\left[h_6 + C_w \left(1 - \frac{h_6}{2T} \right) \right] F_\lambda$, in metres where mid-length of span is below the waterline at draught T</p> <p>where</p> <p>h_6 = vertical distance, in metres, from the waterline at draught T, to the mid-length of span</p> <p>F_λ = 1,0 for $L \leq 200$ m = $[1,0 + 0,0023 (L - 200)]$ for $L > 200$ m</p> <p>C_w = a wave head, in metres = $7,71 \times 10^{-2} L e^{-0,0044L}$ where e = base of natural logarithms 2,7183</p> <p>D_1 = D but need not be taken greater than $1,6T$</p>		

■ *Section 7*
Single bottom structure

7.1 General

7.1.1 Requirements are given in this Section for single bottom construction in association with transverse framing, and are generally applicable to the following ships:

- (a) Cargo ships of less than 500 tons gross tonnage,
- (b) Ships not propelled by mechanical means, and
- (c) Trawlers and fishing vessels.

Cases where a single bottom structure is adopted in association with longitudinal framing will be considered.

7.1.2 Ships with single bottoms are to have a centre girder fitted. In addition, one side girder is to be fitted on each side of the centreline where *B* does not exceed 10 m, and two side girders on each side where *B* is greater than 10 m and does not exceed 17 m. In addition, continuous or intercostal longitudinal stiffeners are to be fitted where the panel size exceeds the ratio 4 to 1. Centre and side girders are to extend as far forward and aft as practicable, and where they cut at bulkheads the longitudinal strength is to be maintained.

7.1.3 Plate floors are to be fitted at every frame, and the tops of floors, in general, may be level from side to side, but in ships having considerable rise of floor, and towards the ends, the depth of the floor plates is to be increased. Floor plates forming part of a watertight or deep tank bulkhead are to be not less than 900 mm in depth measured at the centreline, and the thickness is to be not less than that required for the bottom strake of a bulkhead.

7.1.4 For ships intended to load or unload while aground, see Pt 3, Ch 9, 7 *Bottom strengthening for loading and unloading aground*.

Table 1.7.1 Single bottom girders and floors

Item	Depth, in mm	Thickness, in mm	Face plate area, in cm ²
(1) Centre girder	As for floors	$t = \sqrt{Lk} + 2$ but not less than 6,0	$A_t = 0,67Lk$ but not less than 12,5 See Notes 2 and 3
(2) Side girders	As for floors	$t = \sqrt{Lk}$ but not less than 6,0	$A_t = (0,25L + 5)k$ but not less than 10,0 See Note 3
(3) Floors	Where $B \leq 10$ m $d_f = 40 (B + T)$ Where $B > 10$ m $d_f = 40 (1,5B + T) - 200$ (see Note 1)	$t = \frac{s\sqrt{k}}{s_1} \left(\frac{d_f}{100} + 3 \right)$ but not less than 6,0	$A_f = \frac{5Tsk}{s_1} \left(1 - \frac{2,5}{B} \right)$ See Notes 2 and 3
Symbols			

L, B, T, s, k = as defined in *Pt 4, Ch 1, 1.5 Symbols and definitions 1.5.1*

b_f = breadth of face plate, in mm

d_f = overall depth of floor at the centreline, in mm

s_1 = a standard frame spacing, in mm, and is to be taken as
 $2(L + 240)$

A_f = cross-sectional area of face plate, in cm^2

Note 1. If the side frames are attached to the floors by brackets, the Rule depth of floor may be reduced by 15 per cent and the floor thickness determined using the reduced depth. The brackets are to be flanged and have the same thickness as the floors, and their arm lengths clear of the frame and are to be the same as the reduced floor depth given above.

Note 2. The face plate thickness of floors and centre girder is to be not less than the floor plate thickness.

Note 3. The thickness of face plates is to be: not less than $\frac{b_f}{16\sqrt{k}}$ nor more than $\frac{b_f}{8}$

7.1.5 Provision is made for the free passage of water from all parts of the bottom to the suction, taking into account the pumping rates required.

7.2 Girders and floors

7.2.1 The scantlings of girders and floors are to comply with the requirements of *Table 1.7.1 Single bottom girders and floors*.

■ **Section 8**
Double bottom structure

8.1 Symbols and definitions

8.1.1 The symbols used in this Section are defined as follows:

L, B, T = as defined in *Pt 4, Ch 1, 1.5 Symbols and definitions 1.5.1*

d_{DB} = Rule depth of centre girder, in mm

d_{DBA} = actual depth of centre girder, in mm

h_{DB} = head from top of inner bottom to top of over-flow pipe, in metres

s = spacing of stiffeners, in mm

H_{DB} = height from tank top, at position under consideration, to deck at side amidships, in metres

Z_{BF} = section modulus of bottom frame at bracket floor, in cm^3 .

8.2 General

8.2.1 Except as specified in *Pt 4, Ch 1, 8.2 General 8.2.4*, cargo ships other than tankers are to be fitted with a double bottom extending from the collision bulkhead to the after peak bulkhead, as far as this is practicable and compatible with the design and proper working of the ship.

8.2.2 Where a double bottom is required to be fitted, its depth at the centreline, d_{DB} , is to be in accordance with *Pt 4, Ch 1, 8.3 Girders 8.3.1* and the inner bottom is to be continued out to the ship's side in such a manner as to protect the bottom to the turn of the bilge.

8.2.3 Small wells constructed in the double bottom, in connection with the drainage arrangements of holds, are not to extend in depth more than necessary. A well extending to the outer bottom may, however, be permitted at the after end of the shaft tunnel of the ship. Other well arrangements (e.g. for lubricating oil under main engines) may be considered provided they give protection equivalent to that afforded by the double bottom. In no case shall the vertical distance from the bottom of such a well to a plane coinciding with the keel line be less than 500 mm for passenger ships and cargo ships other than tankers. Keel line is defined in SOLAS Chapter II-1, Part A, *Regulation 2 - Definitions*.

8.2.4 A double bottom need not be fitted in way of watertight compartments used exclusively for the carriage of liquids, provided the safety of the ship in the event of bottom damage is not thereby impaired. In addition, a double bottom need not be fitted on the following ships:

- (a) Cargo ships of less than 500 tons gross tonnage.
- (b) Ships not propelled by mechanical means.
- (c) Trawlers and fishing vessels.

8.2.5 This Section provides for longitudinal or transverse framing in the double bottom, but for ships exceeding 120 m in length and for ships strengthened for heavy cargoes, longitudinal framing is, in general, to be adopted. For the additional requirements for ships specially strengthened for heavy cargoes, see *Pt 4, Ch 7, 1.3 General class notations*.

8.2.6 For ships intended to load or unload while aground, see *Pt 3, Ch 9, 7 Bottom strengthening for loading and unloading aground*.

8.2.7 Girders and the side walls of duct keels are to be continuous, and the structure in way is to be sufficient to withstand the forces imposed by dry-docking the ship.

8.2.8 Adequate access is to be provided to all parts of the double bottom. The edges of all holes are to be smooth. The size of opening should not, in general, exceed 50 per cent of the double bottom depth, unless edge reinforcement is provided. In way of ends of floors and fore and aft girders at transverse bulkheads, the number and size of holes are to be kept to a minimum, and the openings are to be circular or elliptical. Edge stiffening may be required in these positions.

8.2.9 Provision is to be made for the free passage of air and water from all parts of the tank to the air pipes and suction, account being taken of the pumping rates required. To ensure this, sufficient air holes and drain holes are to be provided in all longitudinal and transverse non-watertight primary and secondary members. The drain holes are to be located as close to the bottom as is practicable, and air holes are to be located as close to the inner bottom as is practicable, see also *Pt 3, Ch 10, 5.3 Openings* and *Pt 4, Ch 9, 5.8 Openings in longitudinals*.

8.3 Girders

8.3.1 The minimum depth of the centre girder is to be taken as the greater of the following:

- (a) $d_{DB} = 28B + 205\sqrt{T}$ mm
- (b) $d_{DB} = 50B$ mm, but need not be taken as greater than 2000 mm
- (c) $d_{DB} = 760$ mm.

8.3.2 The centre girder thickness is to be not less than:

$$t = (0,008d_{DB} + 4)\sqrt{k} \text{ mm}$$

nor less than 6,0 mm. The thickness may be determined using the value for d_{DB} without applying the minimum depths specified in *Pt 4, Ch 1, 8.3 Girders 8.3.1* and *Pt 4, Ch 1, 8.3 Girders 8.3.1*.

8.3.3 **In transversely framed ships** where the breadth, B , does not exceed 10 m, no side girders are required, and one vertical stiffener is to be fitted to the floors on each side, about midway between the centreline and the margin plate. One side girder is to be fitted where the breadth, B , exceeds 10 m but does not exceed 20 m, and for greater breadths two girders are to be fitted on each side of the centreline. The non-watertight side girders are to extend as far forward and aft as practicable and are to have a thickness not less than:

$$t = (0,008d_{DB} + 1)\sqrt{k} \text{ mm}$$

nor less than 6,0 mm.

8.3.4 Vertical stiffeners are to be fitted at every bracket floor (see *Pt 4, Ch 1, 8.5 Floors 8.5.7*), and are to have a depth not less than the depth of the tank top frame or 150 mm, whichever is the greater. For ships with a length, L , less than 90 m, stiffeners are to have a depth of not less than $1,65L$ mm with a minimum of 50 mm. The thickness is to be as required for the girder.

Watertight side girders are to have a thickness 1 mm greater than required by *Pt 4, Ch 1, 8.3 Girders 8.3.3* for non-watertight side girders. Where the double bottom tanks are interconnected with side tanks or cofferdams, the thickness is to be as for deep tanks (see *Pt 4, Ch 1, 9.2 Watertight and deep tank bulkheads 9.2.1*) with h , in metres, measured to the highest point at the side tank or cofferdam.

8.3.5 In longitudinally framed ships one side girder is to be fitted where the breadth, B , exceeds 14 m, and two girders are to be fitted on each side of the centreline where B exceeds 21 m. The girders are to extend as far forward and aft as practicable and are to have a thickness not less than:

$$t = (0,0075d_{DB} + 1)\sqrt{k} \quad \text{mm}$$

nor less than 6,0 mm.

In general, a vertical stiffener, having a depth not less than 100 mm and a thickness equal to the girder thickness, is to be arranged midway between floors.

8.3.6 Watertight side girders are to have a plating thickness corresponding to the greater of the following:

- (a) $t = (0,0075d_{DB} + 2)\sqrt{k}$ mm, or
- (b) thickness t as for deep tanks (see *Pt 4, Ch 1, 9.2 Watertight and deep tank bulkheads 9.2.1*) with h , in metres, measured to the highest point of the side tank, or cofferdam if the double bottom is interconnected with these tanks.

8.3.7 Watertight side girder stiffeners are to be in accordance with the requirements for watertight floors, see *Pt 4, Ch 1, 8.5 Floors 8.5.4* and *Pt 4, Ch 1, 8.5 Floors 8.5.5*.

8.3.8 Duct keels, where arranged, are to have a thickness of side plates corresponding to the greater of the following:

- (a) $t = (0,008d_{DB} + 2)\sqrt{k}$ mm, or
- (b) thickness t , as for deep tanks, (see *Pt 4, Ch 1, 9.2 Watertight and deep tank bulkheads 9.2.1*) with h , in metres, measured to the highest point of the side tank, or cofferdam if the double bottom tank is interconnected with these tanks.

8.3.9 The sides of duct keels are, in general, to be spaced not more than 2,0 m apart. Where the sides of the duct keels are arranged on either side of a centreline or side girder, each side is, in general, to be spaced not more than 2,0 m from the centreline or side girder. The inner bottom and bottom shell within the duct keel are to be suitably stiffened. The primary stiffening in the transverse direction is to be suitably aligned with the floors in the adjacent double bottom tanks. Where the duct keels are adjacent to double bottom tanks which are interconnected with side tanks or cofferdams, the stiffening is to be in accordance with the requirements for deep tanks, see *Pt 4, Ch 1, 9.2 Watertight and deep tank bulkheads 9.2.1*. Access to the duct keel is to be by watertight manholes or trunks.

8.3.10 The buckling requirements of *Pt 3, Ch 4, 7 Hull buckling strength* are also to be satisfied.

8.4 Inner bottom plating and stiffening

8.4.1 The thickness of the inner bottom plating in the holds is to be not less than:

$$t = 0,00136(s + 660)\sqrt[4]{k^2 LT} \quad \text{mm}$$

nor less than 6,5 mm in holds and 7,5 mm under hatchways if no ceiling is fitted.

8.4.2 The thickness of the inner bottom plating as determined in *Pt 4, Ch 1, 8.4 Inner bottom plating and stiffening 8.4.1* is to be increased by 2 mm under the hatchways if no ceiling is fitted. If cargo is to be regularly discharged by grabs, see *Pt 4, Ch 1, 2.2 Protection of steelwork 2.2.2*.

8.4.3 A margin plate, if fitted, is to have a thickness throughout 20 per cent greater than that required for inner bottom plating.

8.4.4 Where the double bottom tanks are common with side tanks or cofferdams, the thickness of the inner bottom plating is to be not less than that required for deep tanks (see *Pt 4, Ch 1, 9.2 Watertight and deep tank bulkheads 9.2.1*), with h , in metres, taken to the highest point of the side tank or cofferdam, and K_1 is to be taken as 'elsewhere'.

8.4.5 Inner bottom longitudinals, or tank top frames at bracket floors within the range of cargo holds, are to have a section modulus not less than 85 per cent of the Rule value for bottom longitudinals (see *Pt 4, Ch 1, 6.2 Longitudinal stiffening 6.2.1*) or bottom frames in way of bracket floors (see *Pt 4, Ch 1, 6.3 Transverse stiffening 6.3.1*), whichever is applicable. The unsupported

span of tank top frames is generally not to exceed 2,5 m. Where the double bottom tanks are interconnected with side tanks, hopper and topside tanks or cofferdams, the scantlings are to be not less than those required for deep tanks, see *Pt 4, Ch 1, 9.2 Watertight and deep tank bulkheads 9.2.1*. For higher tensile steel inner bottom longitudinals the requirements of *Pt 4, Ch 1, 6.2 Longitudinal stiffening 6.2.2* are to be complied with where applicable.

8.4.6 The buckling requirements of *Pt 3, Ch 4, 7 Hull buckling strength* are also to be satisfied.

8.5 Floors

8.5.1 **In longitudinally framed ships**, plate floors are to be fitted under bulkheads and elsewhere at a spacing not exceeding 3,8 m. The thickness of non-watertight plate floors is to be not less than:

$$t = (0,009d_{DB} + 1)\sqrt{k} \text{ mm}$$

nor less than 6,0 mm. The thickness need not be greater than 15 mm, but the ratio between the depth of the double bottom and the thickness of the floor is not to exceed $130\sqrt{k}$. This ratio may, however, be exceeded if suitable additional stiffening is fitted. Vertical stiffeners are to be fitted at each longitudinal, having a depth not less than 150 mm and a thickness equal to the thickness of the floors. For ships of length, L , less than 90 m, the depth is to be not less than $1,65L$ mm, with a minimum of 50 mm.

8.5.2 The thickness of watertight floors for longitudinally framed ships is to be not less than:

(a) $t = (0,008d_{DB} + 3)\sqrt{k}$ mm, or

(b) $t = (0,009d_{DB} + 1)\sqrt{k}$ mm

(c) whichever is the greater,

but need not exceed 15 mm on floors of normal depth. The thickness is also to satisfy the requirements for deep tanks (see *Pt 4, Ch 1, 9.2 Watertight and deep tank bulkheads 9.2.1*) with h , in metres, taken to the highest point of the side tank, or cofferdam if the double bottom tank is interconnected with these tanks. The scantlings of stiffeners are to be in accordance with the requirements of *Pt 4, Ch 1, 9.2 Watertight and deep tank bulkheads 9.2.1* for deep tanks, or as required by *Pt 4, Ch 1, 8.5 Floors 8.5.4* whichever is the greater. The stiffeners are to be connected to the inner bottom and shell longitudinals.

8.5.3 Between plate floors, transverse brackets having a thickness not less than $0,009d_{DB}$ mm are to be fitted, extending from the centre girder and margin plate to the adjacent longitudinal. The brackets, which are to be suitably stiffened at the edge, are to be fitted at every frame at the margin plate, and those at the centre girder are to be spaced not more than 1,25 m.

8.5.4 **In transversely framed ships**, plate floors are to be fitted under bulkheads, in way of change in depth of double bottom and elsewhere at a spacing not exceeding 3,0 m. The shell inner bottom plating between these floors is to be supported by bracket floors. The thickness of non-watertight plate floors is to be not less than:

$$t = (0,008d_{DB} + 1)\sqrt{k} \text{ mm}$$

but need not exceed 15 mm and is to be not less than 6 mm. Watertight or strengthened floors are to be fitted below, or in the vicinity of, watertight bulkheads, and their thickness is to be 2 mm greater than that derived above for non-watertight floors, but need not exceed 15 mm on floors of normal depth. If the depth of such floors exceeds 915 mm but does not exceed 2000 mm, the floors are to be fitted with vertical stiffeners spaced not more than 915 mm apart and having a section modulus not less than:

$$Z = 5,41 d_{DBA}^2 h_{DB} s k \times 10^{-9} \text{ cm}^3$$

The ends of the stiffeners are to be sniped.

8.5.5 Where the double bottom tanks are interconnected with side tanks or cofferdams, or where the depth of floor exceeds 2000 mm, the scantlings of watertight floors are to be not less than those required for deep tanks (see *Pt 4, Ch 1, 9.2 Watertight and deep tank bulkheads 9.2.1*), and the ends of the stiffeners are to be bracketed top and bottom.

8.5.6 Where floors form the boundary of a sea inlet box, the thickness of the plating is to be the same as the adjacent shell, but not less than 12,5 mm and need not exceed 25 mm. The scantlings of stiffeners, where required are, in general, to comply with *Pt 4, Ch 1, 9.2 Watertight and deep tank bulkheads 9.2.1* for deep tanks. Sniped ends for stiffeners on the boundaries of these spaces are to be avoided wherever practicable. The stiffeners should be bracketed or the free end suitably supported to provide alignment with backing structure.

8.5.7 **Where bracket floors** are fitted, the bottom frames are to be derived from *Pt 4, Ch 1, 6.3 Transverse stiffening 6.3.1*. The unsupported span of the frames is not to exceed 2,5 m. The breadth of the brackets attaching the frames and the reverse frames to the centre girder and margin plate is to be three-quarters of the depth of the centre girder. The brackets are to be flanged on the unsupported edge and are to have the same thickness as the plate floors.

8.5.8 **Where struts** are fitted to reduce the unsupported span of the frames, reverse frames and longitudinals, they are to have a cross-sectional area of not less than:

$$(a) \quad A = 0,32Z_{BF} \quad \text{cm}^2 \quad \text{for } Z_{BF} \leq 83,5, \text{ or}$$

$$(b) \quad A = 23,2 + \frac{Z_{BF}}{25} \quad \text{cm}^2 \quad \text{for } Z_{BF} > 83,5$$

where Z_{BF} is the modulus, in cm^3 , of the frame or longitudinal based on the effective length between floors as defined in *Pt 3, Ch 3, 3 Structural idealisation*.

■ Section 9 Bulkheads

9.1 General

9.1.1 The requirements of this Section cover watertight and deep tank transverse and longitudinal bulkheads. Requirements are also given for shaft tunnel boundaries and non-watertight bulkheads. For transverse bulkheads in way of ballast holds, stools may be required, see *Pt 4, Ch 7, 10.2 Bulkheads supported by stools*.

9.1.2 The requirements of this Section apply to a vertical system of stiffening on bulkheads. They may also be applied to a horizontal system of stiffening provided that equivalent end support and alignment are provided.

9.1.3 For number and disposition of transverse watertight bulkheads, see *Pt 3, Ch 3, 4 Bulkhead requirements*.

9.1.4 The buckling requirements of *Pt 3, Ch 4, 7 Hull buckling strength* are also to be satisfied.

9.2 Watertight and deep tank bulkheads

9.2.1 The scantlings of watertight and deep tank bulkheads are to comply with the requirements of *Table 1.9.1 Watertight and deep tank bulkhead scantlings* to *Table 1.9.3 Bulkhead end constraint factors*. Where bulkhead stiffeners support deck girders, transverses or pillars over, the requirements of *Pt 4, Ch 1, 4.4 Deck supporting structure 4.4.11* are also to be satisfied.

9.2.2 In way of partially filled holds or tanks, the scantlings and structural arrangements of the boundary bulkheads are to be capable of withstanding the loads imposed by the movement of the liquid in those spaces. The magnitude of the predicted loadings, together with the scantling calculations may require to be submitted, see *Pt 3, Ch 3, 5.4 Design pressure for partially filled tanks*.

9.2.3 In deep tanks, fuel oil or oil carried as cargo is to have a flash point of 60°C or above (closed-cup test). Where tanks are intended for other liquid cargoes of a special nature the scantlings and arrangements will be considered in relation to the nature of the cargo.

9.2.4 Where watertight bulkhead stiffeners are cut in way of watertight doors in the lower part of a bulkhead, the opening is to be suitably framed and reinforced. Where stiffeners are not cut but the spacing between the stiffeners is increased on account of watertight doors, the stiffeners at the sides of the doorways are to be increased in depth and strength so that the efficiency is at least equal to that of the unpierced bulkhead, without taking the stiffness of the door frame into consideration. Watertight recesses in bulkheads are generally to be so framed and stiffened as to provide strength and stiffness equivalent to the requirements for watertight bulkheads.

9.2.5 A centreline bulkhead is, generally, to be fitted in deep tanks which extend from side to side of the ship and are intended for the carriage of fuel oil for the ship's use. The bulkhead may be intact or perforated as desired. If intact, the scantlings are to be as required for boundary bulkheads. If perforated, the modulus of the stiffeners may be 50 per cent of that required for boundary bulkheads, using h_4 measured to the crown of the tank. The stiffeners are to be bracketed at top and bottom. The area of perforation is to be not less than five per cent nor more than 10 per cent of the total area of the bulkhead. Where brackets from horizontal girders on the boundary bulkheads terminate at the centreline bulkhead, adequate support and continuity are to be maintained.

9.3 Shaft tunnels

9.3.1 Where shaft tunnels are required as specified in *Pt 3, Ch 3, 4 Bulkhead requirements* the thickness of the tunnel plating is to comply with *Table 1.9.1 Watertight and deep tank bulkhead scantlings* for holds or deep tanks as appropriate. If the top

plating is well curved, the thickness may be reduced by 10 per cent in dry cargo holds. If the top plating is flat, it is to be not less than 1,1 times the thickness required for watertight bulkheads in dry cargo holds. Under hatchways the top plating is to be increased by 2 mm, unless covered with wood not less than the thickness specified in *Pt 4, Ch 1, 2.2 Protection of steelwork 2.2.2*, which is to be secured by fastenings which do not penetrate the plating. Where it is intended to use plywood or other forms of ceiling of an approved type instead of planking, the thickness will be considered in each case. The tunnel stiffeners are to comply with *Table 1.9.1 Watertight and deep tank bulkhead scantlings* for holds or deep tanks, as appropriate. When the section modulus of curved stiffeners is determined, the values of ω_1 and ω_2 are to be taken as 1,0. The span of the stiffener, l_e , is to be taken as the overall height of the tunnel, measured vertically at the centreline of the tunnel. If the tunnel top is flat, scantlings of the stiffeners are also to comply with *Pt 4, Ch 1, 4.3 Deck stiffening*. The lower end connection to the tank top is to be welded. Additional strengthening is to be fitted under the heels of pillars or masts stepped on the tunnel.

9.4 Non-watertight bulkheads

9.4.1 The scantlings are to be in accordance with *Table 1.4.8 Non-watertight pillar bulkheads*.

Table 1.9.1 Watertight and deep tank bulkhead scantlings

Item and requirement	Watertight bulkheads	Deep tank bulkheads
(1) Plating thickness for plane, symmetrically corrugated and double plate bulkheads	$t = 0,004sf\sqrt{h_4k}$ mm but not less than 5,5 mm	$t = 0,004sf\sqrt{\frac{\rho h_4k}{1,025} + 2,5}$ mm but not less than 6,5 mm, where $L < 90$ m not less than 7,5 mm, where $L \geq 90$ m
	In the case of symmetrical corrugations, s is to be taken as b or c in <i>Figure 3.3.1 Corrugation dimensions</i> in Pt 3, Ch 3, whichever is the greater	
(2) Modulus of rolled and built stiffeners, swedges, double plate bulkheads and symmetrical corrugations	$Z = \frac{skh_4l_e^2}{71\gamma(\omega_1 + \omega_2 + 2)} \text{ cm}^3$	$Z = \frac{\rho skh_4l_e^2}{22\gamma(\omega_1 + \omega_2 + 2)} \text{ cm}^3$
	In the case of symmetrical corrugations, s is to be taken as p, see also Note 2	
(3) Inertia of rolled and built stiffeners and swedges	—	$I = \frac{2,3}{k}l_e Z \text{ cm}^4$
(4) Symmetrical corrugations and double plate bulkheads	Additional requirements to be complied with as detailed in <i>Table 1.9.2 Symmetrical corrugations and double plate bulkheads (additional requirements)</i>	
(5) Stringers or webs supporting vertical or horizontal stiffening		
(a) Modulus	$Z = 5,5kh_4Sl_e^2 \text{ cm}^3$	$Z = 11,7\rho kh_4Sl_e^2 \text{ cm}^3$
(b) Inertia	—	$I = \frac{2,5}{k}l_e Z \text{ cm}^4$
	Symbols	

s, S, l, k, ρ as defined in Pt 4, Ch 1, 1.5 Symbols and definitions 1.5.1

d_w = web depth of stiffening member, in mm

$$f = 1,1 - \frac{s}{2500S} \text{ but not to be taken greater than } 1,0$$

h_4 = load head, in metres measured as follows:

- (a) For watertight bulkhead plating, the distance vertically from a point one-third of the height of the plate above its lower edge to a point 0,91 m above the bulkhead deck at side or perpendicular to the deepest equilibrium waterline in damaged condition obtained from applicable damage stability calculations, whichever is the greater, see also Figure 3.5.2 Heads for watertight and deep tank bulkheads in Pt 3, Ch 3
- (b) For deep tank bulkhead plating, the distance from a point one-third of the height of the plate above its lower edge to the top of the tank, or half the distance to the top of the overflow, whichever is the greater, see also Figure 3.5.2 Heads for watertight and deep tank bulkheads in Pt 3, Ch 3
- (c) For watertight bulkhead stiffeners or girders, the distance vertically from the middle of the effective length to a point 0,91 m above the bulkhead deck at sideside, or perpendicular to the deepest equilibrium waterline in damaged condition obtained from applicable damage stability calculations, whichever is the greater, see also Figure 3.5.2 Heads for watertight and deep tank bulkheads in Pt 3, Ch 3
- (d) For deep tank bulkhead stiffeners or girders, the distance from the middle of the effective length to the top of the tank, or half the distance to the top of the overflow, whichever is the greater, see also Figure 3.5.2 Heads for watertight and deep tank bulkheads

l_e = effective length of stiffening member, in metres, and for bulkhead stiffeners, to be taken as $l - e_1 - e_2$, see also Figure 1.9.1 End connections

ρ = spacing of corrugations as shown in Figure 3.3.1 Corrugation dimensions

γ = 1,4 for rolled or built sections and double plate bulkheads

= 1,6 for flat bars

= 1,1 for symmetrical corrugations of deep tank bulkheads

= 1,0 for symmetrical corrugations of watertight bulkheads

ω, θ = as defined in Table 1.9.3 Bulkhead end constraint factors, see also Figure 1.9.1 End connections

Note 1. In no case are the scantlings of deep tank bulkheads to be less than the requirements for watertight bulkheads where watertight bulkheads are required by Pt 3, Ch 3, 5 Design loading.

Note 2. In calculating the actual modulus of symmetrical corrugations the panel width b is not to be taken greater than that given by Pt 3, Ch 3, 3.2 Geometric properties of section

Note 3. For rolled or built stiffeners with flanges or face plates, the web thickness is to be not less than $\frac{d_w}{60\sqrt{k}}$ whilst for flat bar stiffeners the

web thickness is to be not less than $\frac{d_w}{18\sqrt{k}}$

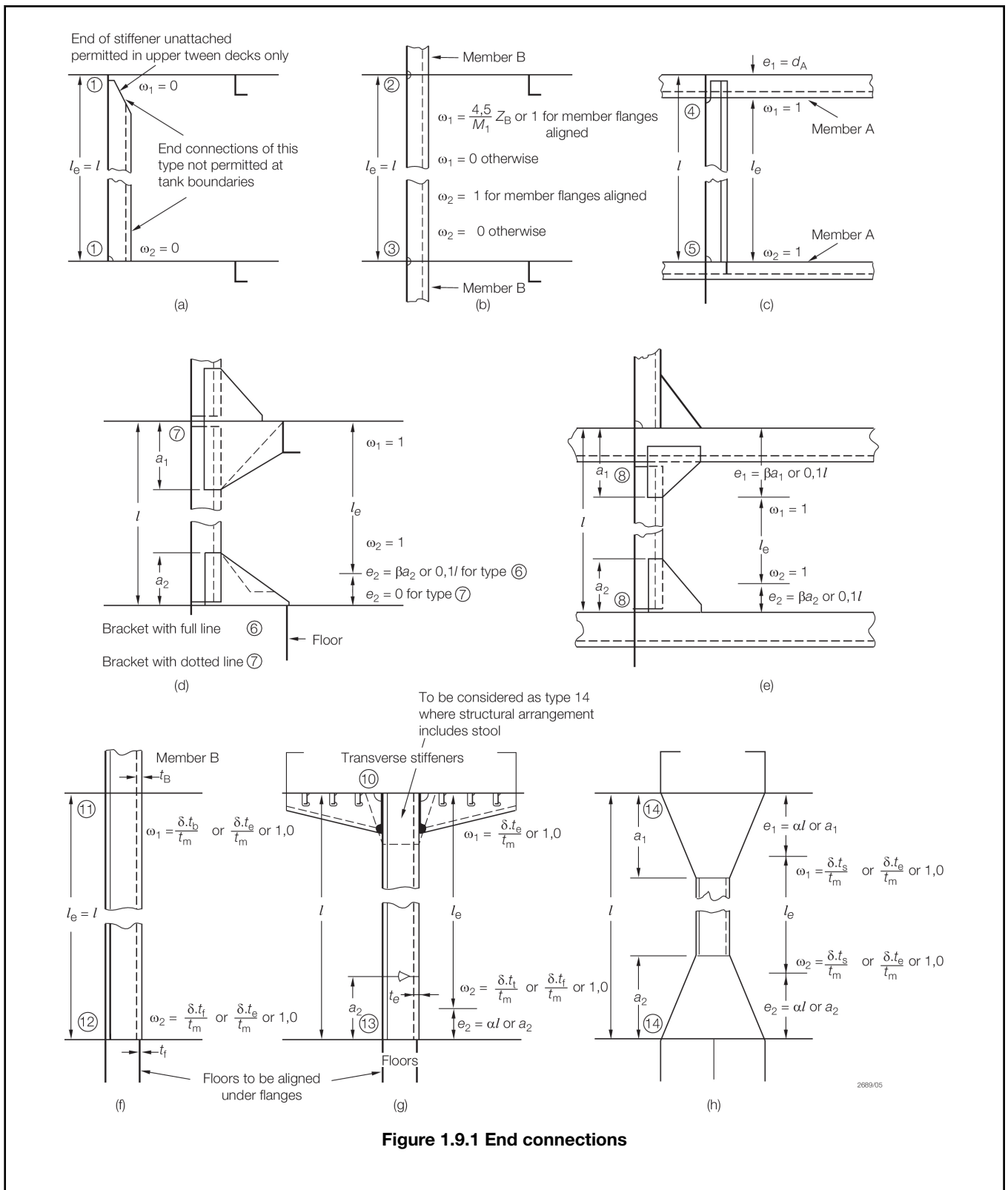

Figure 1.9.1 End connections

Table 1.9.2 Symmetrical corrugations and double plate bulkheads (additional requirements)

Symbols	Type of bulkhead	Parameter	Watertight bulkheads	Deep tank bulkheads
<p>s, k as defined in Pt 4, Ch 1, 1.5 Symbols and definitions 1.5.1</p> <p>b = panel width as shown in Figure 3.3.1 Corrugation dimensions in Pt 3, Ch 3 Structural Design</p> <p>d = depth, in mm, of symmetrical corrugation or double plate bulkhead</p> <p>l_e as defined in Table 1.9.1 Watertight and deep tank bulkhead scantlings</p> <p>A_w = shear area, in cm², of webs of double plate bulkhead</p> <p>θ = angle of web corrugation to plane of bulkhead</p>	Symmetrical ly corrugated, see also Notes 1 and 2	$\frac{b}{t}$	Not to exceed: $85\sqrt{k}$ at top, and $70\sqrt{k}$ at bottom	Not to exceed: $70\sqrt{k}$ at top, and at bottom
		d	—	To be not less than: $39l_e$ mm
		θ	To be not less than 40°	
<p>Note 1. The plating thickness at the middle of span l_e of corrugated or double plate bulkheads is to extend not less than $0,2l_e$ m above mid span.</p> <p>Note 2. Where the span of corrugations exceeds 15 m, a diaphragm plate is to be arranged at about mid-span.</p> <p>Note 3. See also Pt 3, Ch 10, 5.2 Arrangements at intersections of continuous secondary and primary members 5.2.1.</p>	Double plate, see also Notes 1 and 3	$\frac{s}{t}$	Not to exceed:	$75\sqrt{k}$ at top, and $65\sqrt{k}$ at bottom
		$\frac{d}{t_w}$	Not to exceed:	$85\sqrt{k}$ at top, and $75\sqrt{k}$ at bottom
		d	—	To be not less than: $39l_e$ mm
		A_w	To be not less than:	To be not less than:
		$\frac{0,12Z}{l_e}$ cm ² at top and $\frac{0,18Z}{l_e}$ cm ² at bottom	$\frac{0,07Z}{l_e}$ cm ² at top and $\frac{0,10Z}{l_e}$ cm ² at bottom	

Table 1.9.3 Bulkhead end constraint factors

Type	End connection (see Figure 1.9.1 End connections)	ω	e	μ
Rolled or built stiffeners and swedges				
1	End of stiffeners unattached or attached to plating only	0	0	—

2	Members with webs and flanges (or bulbs) in line and attached at deck or horizontal girder, see also Note 1	Adjacent member of B of smaller modulus		The lesser of $\frac{4,5Z_B}{M_1}$ or 1,0	0	—
3		Adjacent member of B of same or larger modulus		1,0	0	—
4	Bracketless connection to longitudinal member	Member A within length l		1,0	$\frac{d_A}{1000}$	—
5		Member A outside length l		1,0	0	—
6	Bracketed connection	To transverse member	Bracket extends to floor	1,0	The lesser of βa or $0,1l$	—
7			Otherwise	1,0	0	—
8		To longitudinal member		1,0	The lesser of βa or $0,1l$	—
Symmetrical corrugations or double plate bulkheads						
9	Welded directly to deck - no bulkhead in line	No longitudinal brackets		0	0	—
10		With longitudinal brackets and transverse stiffeners supporting corrugated bulkhead		The lesser of $\frac{\delta t_e}{t_m}$ or 1,0	0	—
11	Welded directly to deck or girder	Bulkhead B, having same section, in line		The least of $\frac{\delta t_B}{t_m}$ or $\frac{\delta t_e}{t_m}$ or 1,0	0	—
12	Welded directly to tank top and effectively supported by floors in line with each bulkhead flange, see also Note 2	Thickness at bottom same as that at mid-span		The least of $\frac{\delta t_f}{t_m}$ or $\frac{\delta t_e}{t_m}$ or 1,0	0	—
13		Thickness at bottom greater than that at mid-span		The least of $\frac{\delta t_f}{t_m}$ or $\frac{\delta t_e}{t_m}$ or 1,0	The lesser of a or a	The lesser of $\frac{t_f}{t_m}$ or $\frac{t_e}{t_m}$
14	Welded to stool efficiently supported by ship's structure		For deep tank bulkheads 1,0 For watertight bulkheads the least of $\frac{\delta t_s}{t_m}$ or $\frac{\delta t_e}{t_m}$ or 1,0	The lesser of a or a	$\frac{10Z_s}{M_2}$	
Symbols						

s, l, p, k , as defined in Pt 4, Ch 1, 1.5 Symbols and definitions 1.5.1

a = height, in metres, of bracket or end stool or lowest strake of plating of symmetrically corrugated or double plate bulkheads, see Figure 1.9.1 End connections

d_A = web depth, in mm, of adjacent member A

e = effective length, in metres, of bracket or end stool, see Figure 1.9.1 End connections

$h_o = h_4$ but measured from the middle of the overall length l

ω, p, h as defined in Table 1.9.1 Watertight and deep tank bulkhead scantlings

t_B = thickness, in mm, of flange plating of member B

t_f = thickness, in mm, of supporting floor

t_m, t_e = thickness, in mm, of flange plating of corrugation or double plate bulkhead at mid-span or end, respectively Subscripts 1 and 2 when applied to ω, e , and a refer to the top and bottom ends of stiffener

$$M_1 = \frac{h_4 s l^2}{71} e \text{ for watertight bulkheads}$$

$$= \frac{p h_4 s l^2}{22} e \text{ for deep tank bulkheads}$$

$$M_2 = \frac{h_o s l^2}{71} \text{ for watertight bulkheads}$$

$$= \frac{p h_o s l^2}{22} \text{ for deep tank bulkheads}$$

In the case of symmetrical corrugations $s = p$

Z_B = section modulus, in cm^3 , of adjacent member B

Z_s = section modulus, in cm^3 , of horizontal section of stool adjacent to deck or tank top over breadth s or p (as applicable)

All material which is continuous from top to bottom of stool may be included in the calculation

α = a factor depending on μ and determined as follows:

where $\mu \leq 1,0 \alpha = 0$

where $\mu > 1,0 \alpha = 0,5 - \frac{1}{\sqrt{2\mu + 2}}$

β = a factor depending on the end bracket stiffening and to be taken as: 1,0 for brackets with face bars directly connected to stiffener face bars
0,7 for flanged brackets
0,5 for unflanged brackets

μ = a factor representing end constraint for symmetrical corrugation and double plate bulkheads

ω = an end constraint factor relating to the different types of end connection, see Figure 1.9.1 End connections

t_s = thickness, in mm, of stool adjacent to bulkhead

δ = 1,0 generally

$\delta = \frac{0,932\sqrt{k}}{\xi}$ for corrugated watertight bulkheads

$\xi = 1,0$ where full continuity of corrugation webs is provided at the ends

$\xi = \text{greater of } 1,0 \text{ and } (\eta + 0,333)$ where full continuity is not provided

$\eta = \text{lesser of } 1,0 \text{ and } \frac{50t_m\sqrt{k}}{b}$ for welded sections

$\eta = \text{lesser of } 1,0 \text{ and } \frac{60t_m\sqrt{k}}{b}$ for cold formed sections

Note 1. Where the end connection is similar to type 2 or 3, but member flanges (or bulbs) are not aligned and brackets are not fitted, $\omega=0$.

Note 2. Where the end connection is similar to type 12 or 13, but a transverse girder is arranged in place of one of the supporting floors, special consideration will be required.

Section

- 1 **General**
- 2 **Longitudinal strength**
- 3 **Deck structure**
- 4 **Shell envelope plating**
- 5 **Shell envelope framing**
- 6 **Double bottom**
- 7 **Peak, watertight and deep tank bulkheads**
- 8 **Bow doors and inner doors**
- 9 **Subdivision structure on vehicle deck**
- 10 **Masts and standing rigging**
- 11 **Miscellaneous openings**
- 12 **External glass balustrades**
- 13 **Direct calculation**

■ *Section 1*
General

1.1 Application

1.1.1 This Chapter applies to sea-going roll on-roll off cargo ships, passenger ships, sailing passenger ships and passenger yachts, defined as follows:

- (a) A passenger ferry is defined as a ship specially designed and constructed for the carriage of passengers on a regular scheduled service between specified ports operating in reasonable weather conditions.
- (b) A passenger/vehicle ferry is defined as a ship specially designed and constructed for the carriage of passengers and vehicles on a regular scheduled service between specified ports operating in reasonable weather conditions.
- (c) A roll on-roll off cargo ship is defined as a ship specially designed and constructed for the carriage of vehicles, and cargo in pallet form or in containers, and loaded/unloaded by wheeled vehicles.
- (d) A passenger ship is defined as a ship specially designed and constructed for the carriage of more than 12 passengers.
- (e) A sailing passenger ship is defined as a ship specially designed and constructed for the carriage of more than 12 passengers and incorporating sail devices which are intended to be the primary means of propulsion.
- (f) A passenger yacht is defined as a yacht that is specially designed and constructed in accordance with Administration requirements for passenger yachts with due regard to the applicability of the conventions as given in *Pt 1, Ch 2, 1.1 General 1.1.9*, as determined in accordance with the British Red Ensign Group *Code of Practice for Yachts Carrying 13 to 36 Passengers (Passenger Yacht Code)*, and subsequent revisions.

1.1.2 Ships intended to operate only in certain areas or conditions which have been agreed by the Committee, as defined in *Pt 1, Ch 2 Classification Regulations*, will receive individual consideration on the basis of the Rules with respect to the environmental conditions agreed for the design basis and approval.

1.1.3 The scantlings and arrangements are to be as required by *Pt 4, Ch 1 General Cargo Ships* except as otherwise specified in this Chapter.

1.1.4 The scantlings of the primary supporting structure for multi-decked passenger ships are to be assessed by direct calculation, in accordance with the *ShipRight Structural Design Assessment Procedure* for passenger ships, wherever:

- (a) the superstructure will be subjected to significant load from flexure of the hull girder; or
- (b) it is required to utilise the load-carrying capability of the superstructure for longitudinal strength; or
- (c) a limited number of transverse bulkheads above the bulkhead deck are present to carry the racking response.

See also *Pt 4, Ch 2, 1.3 Class notations 1.3.7* and *Pt 4, Ch 2, 13 Direct calculation*.

1.1.5 The scantlings of the primary supporting structure of a vehicle ferry, passenger/vehicle ferry, roll on–roll off cargo ship, roll on–roll off passenger ship or vehicle carrier are to be assessed by direct calculation in accordance with the *ShipRight Structural Design Assessment Procedure* for Ro–Ro ships and the *ShipRight Construction Monitoring Procedure*. See also *Pt 4, Ch 2, 1.3 Class notations 1.3.7* and *Pt 4, Ch 2, 13 Direct calculation*.

1.1.6 For the purpose of providing operational information to the Master for safe return to port after a flooding casualty, passenger ships having a Load Line length of 120 m or more or having three or more main vertical zones are to have:

- (a) an onboard stability computer; or
- (b) shore-based support.

Where an onboard computer system having a stability computation capability is provided, the system is to be certified in accordance with LR's document entitled *Approval of Longitudinal Strength and Stability Calculations Programs*, see also *Pt 1, Ch 2, 1.1 General 1.1.11*.

1.2 Structural configuration

1.2.1 The requirements provide for a basic structural configuration of a multi-deck hull which includes a double bottom, and in some cases wing tanks up to the lowest deck.

1.2.2 For passenger ships, the structural arrangements detailed in Chapter II-1, Part B, of the *International Convention for the Safety of Life at Sea, 1974*, and applicable amendments as they apply to passenger ships are to be complied with in their entirety.

1.2.3 Where bulkheads are omitted in accordance with *Pt 3, Ch 3, 4 Bulkhead requirements*, a system of partial bulkheads, web frames and deck transverses should be fitted to provide equivalent transverse strength.

1.2.4 Longitudinal framing is, in general, to be adopted at the strength deck and at the bottom, but special consideration will be given to proposals for transverse framing in these regions.

1.2.5 Reference should be made to the Regulations of the *International Convention for the Safety of Life at Sea, 1974* and applicable amendments and to the relevant Statutory Requirements of the National Authority of the country in which the ship is to be registered.

1.2.6 Attention is also drawn to the requirements for passenger ships given in:

- Bulkhead requirements, see *Pt 3, Ch 3, 4 Bulkhead requirements*
- Closing arrangements for shell, deck and bulkheads, see *Pt 3, Ch 11, 6 Miscellaneous openings, Pt 3, Ch 11, 8 Side and stern doors and other shell openings* and *Pt 3, Ch 11, 9 Watertight doors in bulkheads below the freeboard deck*
- Electrical installations, see *Pt 6, Ch 2 Electrical Engineering*
- Fire protection, detection and extinction, see SOLAS Reg. II-2 *Part B - Prevention of fire and explosion*¹ and *Part C - Suppression of fire*.

1.2.7 Attention is drawn to National Authority requirements relating to the stowage and securing of vehicles and cargo units on board roll on–roll off ships. Steel used for the construction of fixed securing fittings attached to the ship's structure is to comply with the requirements of *Rules for the Manufacture, Testing and Certification of Materials* (hereinafter referred to as the *Rules for the Manufacture, Testing and Certification of Materials, July 2015*), or with an equivalent acceptable specification. Due account is to be taken of the grade and tensile strength of the hull material in way of the attachment and the chemical composition of the steel is to be such as to ensure acceptable qualities of weldability.

1.2.8 Sailing passenger ships are to be fitted with auxiliary propulsive power to ensure adequate speed and manoeuvrability of the vessel in conditions when the sail systems are not available for use. The auxiliary propulsion and other essential machinery are to comply with the requirements of *Pt 5 Main and Auxiliary Machinery* of the Rules, as applicable.

1.2.9 Sail systems may be made up in the form of soft sails, semi-rigid and rigid sail configurations including wind turbines or systems incorporating rotating cylinders.

1.2.10 For sailing vessels, a continuous visual read out of the apparent wind speed and direction is to be available to the ship's master when the vessel is under way. Sail control and service systems are to provide adequate speed of response to neutralise the

sail system in the event of high wind conditions. Sufficient information and evidence is to be submitted to substantiate that the foregoing arrangements are in place.

1.2.11 For sailing passenger ships, the Rules for classification will, in principle, apply to the mast arrangements and standing gear, but will exclude running gear, yards, booms and sail arrangements.

1.2.12 For sailing passenger ships, the equipment requirements will be in accordance with the letter and numeral two grades higher than that corresponding to the calculated Equipment Numeral.

1.3 Class notations

1.3.1 In general, ships complying with the requirements of this Chapter will be eligible to be classed:

- '100A1 passenger ferry', or
- '100A1 passenger/vehicle ferry' or
- '100A1 roll on-roll off cargo ship', or
- '100A1 roll on-roll off passenger ship', or
- '100A1 vehicle carrier', or
- '100A1 passenger ship', or
- '100A1 passenger yacht', or
- '100A1 sailing passenger ship'.

1.3.2 For passenger ships that comply with the requirements of the European Council Directive 98/18/EC of 17 March 1998 on safety rules and standards for passenger ships, and subsequent revisions, the following class notations may be appended to the main class notation:

- (a) **EU(A)**. This class notation will be assigned to a passenger ship engaged on domestic voyages other than voyages covered by Classes B, C and D.
- (b) **EU(B)**. This class notation will be assigned to a passenger ship engaged on domestic voyages in the course of which it is at no time more than 20 miles from the line of coast, where shipwrecked persons can land, corresponding to the medium tide height.
- (c) **EU(C)**. This class notation will be assigned to a passenger ship engaged on domestic voyages in sea areas where the probability of exceeding 2,5 m significant wave height is smaller than 10 per cent over a one-year period for all-year-round operation, or over a specific restricted period of the year for operation exclusively in such period (e.g. summer period operation), in the course of which it is at no time more than 15 miles from a place of refuge, nor more than 5 miles from the line of coast, where shipwrecked persons can land, corresponding to the medium tide height.
- (d) **EU(D)**. This class notation will be assigned to a passenger ship engaged on domestic voyages in sea areas where the probability of exceeding 1,5 m significant wave height is smaller than 10 per cent over a one-year period for all-year-round operation, or over a specific restricted period of the year for operation exclusively in such period (e.g. summer period operation), in the course of which it is at no time more than 6 miles from a place of refuge, nor more than 3 miles from the line of coast, where shipwrecked persons can land, corresponding to the medium tide height.

1.3.3 A ship assigned a class notation incorporating the word 'passenger', which is also designed to fulfil other functions not associated with passenger carrying is to comply with the requirements of this Chapter for passenger ships together with the requirements of the relevant Chapter of this Part for the particular ship type.

1.3.4 Where ferries are specially reinforced for the carriage of trains on fixed rails, the class notation will also include the word 'train'.

1.3.5 The Regulations for the classification and assignment of class notations are given in *Pt 1, Ch 2 Classification Regulations*, to which reference should be made.

1.3.6 The 'ShipRight Procedures' for hull construction of ships are detailed in *Pt 3, Ch 16 ShipRight Procedures for the Design, Construction and Lifetime Care of Ships* and the classification notations and descriptive notes associated with these procedures are given in *Pt 1, Ch 2, 2 Character of classification and class notations*.

1.3.7 The 'Structural Design Assessment' (**SDA**) and 'Construction Monitoring' (**CM**) procedures detailed in the *ShipRight Procedures Manual*, published by Lloyd's Register (hereinafter referred to as 'LR'), are mandatory for passenger ships where it is considered that the superstructure will be subjected to a significant load from flexure of the hull girder; or, where it is required to utilise the load carrying capability of the superstructure for longitudinal strength, and for other passenger ships of abnormal hull form, or of unusual structural configuration or complexity.

1.4 Information required

1.4.1 In addition to the information and plans required by *Pt 3, Ch 1, 5 Information required*, the following details are to be submitted:

- The intended service areas required for ships designed to operate within specified geographical limits.
- Stern or bow ramps.
- Bow, stern and side doors.
- Movable decks, if fitted, including stowing arrangements for portable components.
- Sail plans and associated operational and design conditions, including apparent wind speeds (sailing ships).
- Masts and all structural components of the standing rigging (sailing ships).
- The standing rigging and all standing rigging attachments (sailing ships).
- The design deck loadings including details of wheeled vehicles, see *Pt 3, Ch 9, 3 Decks loaded by wheeled vehicles*, and trains, where applicable.
- Locations of fixed securing points for wheeled vehicles, with indication of the magnitude and direction of the imposed lashing force.

1.5 Symbols

1.5.1 For the definition of symbols not defined in this Chapter, see *Pt 4, Ch 1, 1.5 Symbols and definitions*.

1.5.2 The following definitions apply to ships employing sails:

Standing rigging	– Rigging of fixed length used to support masts/bowsprit.
Running rigging	– Rigging used to control yards, booms and sails and which may pass over revolving sheaves.
Apparent wind speed	– The vector resultant of the combination of real wind speed and ship velocity.

■ Section 2 Longitudinal strength

2.1 General

2.1.1 Longitudinal strength calculations are to be made in accordance with the requirements given in *Pt 3, Ch 4 Longitudinal Strength* and the additional notes contained in this Section.

2.1.2 The design vertical wave bending moments and design wave shear forces to be used in *Pt 3, Ch 4 Longitudinal Strength* are to be determined in accordance with *Pt 4, Ch 2, 2.5 Design wave shear force* and *Pt 4, Ch 2, 2.4 Design vertical wave bending moments* below. For ships of unusual hullform or where their design parameters are outwith the applicability of the Rules, see *Pt 3, Ch 4 Longitudinal Strength*, special consideration will be given to the values and distributions of the wave induced global loads.

2.1.3 The still water bending moment and shear force envelopes are to take into account the requirements of *Pt 4, Ch 2, 2.3 Still water bending moments and shear forces*.

2.1.4 For ships where the side shell or side casings contain large openings or where the effectiveness of the superstructures in resisting hull girder bending loads is expected to be reduced by the presence of large numbers of windows or openings, the combined hull and superstructure response may require to be verified using direct calculation techniques.

2.2 Calculation of hull section modulus

2.2.1 The calculation of section modulus is to be in accordance with *Pt 3, Ch 3, 3.4 Calculation of hull section modulus* and the additional notes in this Section. In general, the effective sectional area of continuous longitudinal strength members, after

deduction of openings, is to be used for the calculation of midship section modulus. For ships where the effectiveness of the superstructure is only partial due to the presence of large or numerous shell openings or discontinuities in the shell envelope, an equivalent section modulus for the purposes of this Section may be derived using direct calculations in accordance with the SDA procedure relevant to the ship type.

2.2.2 Structural members which contribute to the overall hull girder strength are to be carefully aligned so as to avoid discontinuities resulting in abrupt variations of stresses and are to be kept clear of any form of openings which may affect their structural performances.

2.2.3 In general, short superstructures, *see also Pt 3, Ch 3, 3.4 Calculation of hull section modulus 3.4.2*, or deckhouses will not be accepted as contributing to the global longitudinal or transverse strength of the ship. However, where it is proposed to include substantial continuous stiffening members, special consideration will be given to their inclusion on submission of the designer's/ Builder's calculations, *see also Pt 4, Ch 2, 2.6 Buckling strength*.

2.2.4 Adequate transition arrangements are to be fitted at the ends of effective continuous longitudinal strength members in the deck and bottom structures.

2.2.5 Scantlings of all continuous longitudinal members of the hull girder based on the minimum section stiffness requirements determined from *Pt 4, Ch 4, 5 Superstructures and deckhouses* are to be maintained within $0,4L$ amidships. However, in special cases, based on consideration of type of ship, hull form and loading conditions, the scantlings may be gradually reduced towards the ends of the $0,4L$ part, bearing in mind the desire not to inhibit the ship's loading and operational flexibility.

2.2.6 Structural material which is longitudinally continuous but which is not considered to be fully effective for longitudinal strength purposes may be specially considered. The global longitudinal strength assessment must take into account the presence of such material when it can be considered effective. The consequences of failure of such structural material and subsequent redistribution of stresses into or additional loads imposed on the remaining structure is to be considered.

2.2.7 In particular, all longitudinally continuous material will be fully effective in tension whereas this may not be so in compression due to a low buckling capability. In this case, it may be necessary to derive and apply different hull girder section moduli to the hogging and sagging bending moment cases.

2.3 Still water bending moments and shear forces

2.3.1 The design still water hogging and sagging bending moment distribution envelope, M_S , is to be taken as the maximum sagging (negative) and maximum hogging (positive) still water bending moments, calculated at each position along the ship. The maximum moments from all loading conditions are to be used to define the still water bending moment distribution envelope.

2.3.2 It is normal for ships which have a low deadweight requirement or a uniform loading rate in association with a low block coefficient to have a hogging still water bending moment in all conditions of loading. For these ships, the maximum design sagging still water bending moment may be taken as the minimum actual hogging bending moment.

2.3.3 The design still water shear force distribution envelope, Q_S , is to be taken as the maximum positive and negative shear force values, calculated at each position along the ship. The maximum shear forces from all loading conditions are to be used to define the still water shear force distribution envelope.

2.4 Design vertical wave bending moments

2.4.1 The minimum value of vertical wave bending moment, M_w at any position along the ship may be taken as follows:

$$M_w = f_1 f_2 C_2 M_{w0} \text{ kNm(tonne - f m)}$$

where

$$M_{w0} = 0,1 C_1 L^2 B_{WL} (C_b + 0,7) \text{ kNm}$$

$$(M_{w0} = 0,0102 C_1 L^2 B_{WL} (C_b + 0,7) \text{ tonne-f m})$$

$$B_{WL} = \text{maximum waterline breadth, in metres}$$

= C_1 , C_2 , L and C_b are given in *Pt 3, Ch 4, 5 Hull bending strength*

= and

f_1 = is given in *Pt 3, Ch 4, 5 Hull bending strength*

where

f_2 = is the hogging, f_{fH} , or sagging, f_{fS} , correction factor based on the amount of bow flare, stern flare, length and effective buoyancy of the aft end of the ship above the waterline

f_{fS} = is the sagging (negative) moment correction factor and is to be taken as

$f_{fS} = -1,10R_A^{0,3}$ for values of $R_A > 1,0$

$f_{fS} = -1,10$ for values of $R_A \leq 1,0$

f_{fH} = is the hogging (positive) moment correction factor and is to be taken as

$$f_{fH} = \frac{1,9C_b}{(C_b + 0,7)}$$

= R_A is an area ratio factor, see Pt 4, Ch 2, 2.4 Design vertical wave bending moments 2.4.2.

2.4.2 The area ratio factor, R_A , for the combined stern and bow shape is to be derived as follows:

$$R_A = \frac{30(A_{BF} + 0,5A_{SF})}{LB_{WL}}$$

where

A_{BF} = is the bow flare area, in m²

A_{SF} = is the stern flare area, in m²

2.4.3 The bow flare area, A_{BF} , is illustrated in *Figure 2.2.1 Derivation of bow and stern flare areas* and may be derived as follows:

$$A_{BF} = A_{UB} - A_{LB} \text{ m}^2$$

where

A_{UB} = is half the water plane area at a waterline of $T_{C,U}$ of the bow region of the hull forward of $0,8L$ from the AP

A_{LB} = is half the water plane area at the design draught of the bow region of the hull forward of $0,8L$ from the AP

= Note the AP is to be taken at the aft end of L

= The design draught is to be taken as T , see Pt 3, Ch 1, 6.1 Principal particulars.

Alternatively the following formula may be used

$$A_{BF} = 0,005L(b_0 + 2b_1 + b_2) + b_0 a/2 \text{ m}^2$$

where

b_0 = projection of $T_{C,U}$ waterline outboard of the design draught waterline at the FP, in metres, see *Figure 2.2.1 Derivation of bow and stern flare areas*

b_1 = projection of $T_{C,U}$ waterline outboard of the design draught waterline at $0,9L$ from the AP, in metres

b_2 = projection of $T_{C,U}$ waterline outboard of the design draught waterline at $0,8L$ from the AP, in metres

a = projection of $T_{C,U}$ waterline forward of the FP, in metres

$T_{C,U}$ = is a waterline taken $C_1/2$ m above the design draught

$$T_{C,U} = T + \frac{C_1}{2} \text{ m}$$

C_1 = is given in Pt 3, Ch 4 Longitudinal Strength Table 4.5.1 Wave bending moment factor

where

= For ships with large bow flare angles above the $T_{C,U}$ waterline the bow flare area may need to be specially considered.

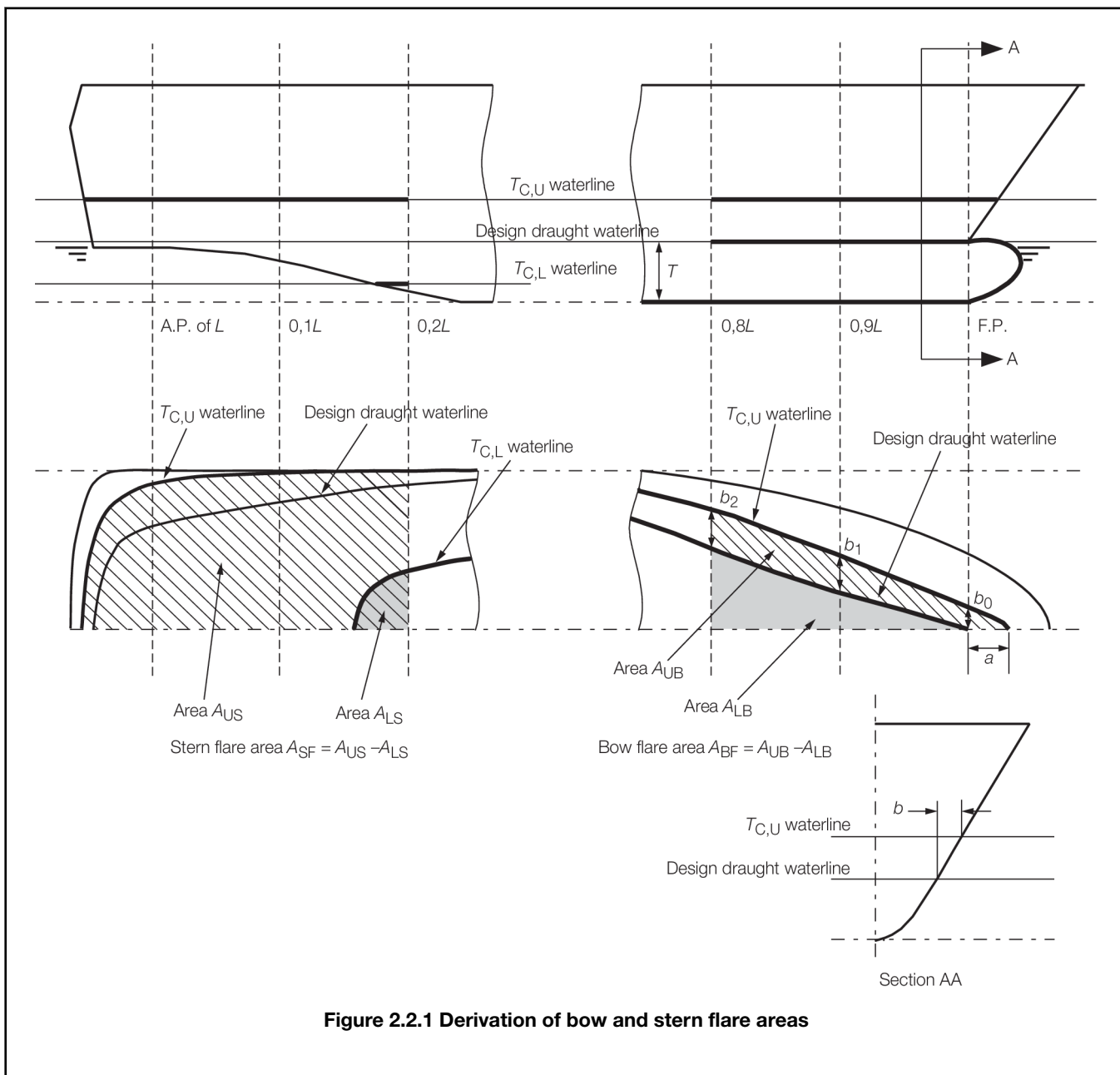

Figure 2.2.1 Derivation of bow and stern flare areas

2.4.4 The stern flare area, A_{SF} , is illustrated in *Figure 2.2.1 Derivation of bow and stern flare areas* and is to be derived as follows:

$$A_{SF} = A_{US} - A_{LS} \text{ m}^2$$

where

A_{US} = is half the water plane area at a waterline of $T_{C,U}$ the stern region of the hull aft of $0,2L$ from the AP

A_{LS} = is half the water plane area at a waterline of $T_{C,L}$ the stern region of the hull aft of $0,2L$ from the AP

$T_{C,L}$ = is a waterline taken $C \frac{1}{2}$ m below the design draught

where

$$T_{C,L} = T - \frac{C_1}{2} m$$

= For ships with tumblehome in the stern region, the maximum breadth at any waterline less than $T_{C,U}$ is to be used in the calculation of A_{US} . The effects appendages including bossings are to be ignored in the calculation of A_{LS} .

2.4.5 Direct calculation methods may be used to derive the vertical wave bending moments, see Pt 3, Ch 4, 2.5 Direct calculation procedures.

2.4.6 The sagging correction factor, f_{fS} , in the vertical wave bending moment formulation in Pt 4, Ch 2, 2.3 Still water bending moments and shear forces 2.3.1 may be derived by direct calculation methods. Appropriate direct calculation methods include a combination of long-term ship motion analysis, non linear ship motion analysis and static balance on a wave crest or trough.

2.5 Design wave shear force

2.5.1 The design vertical wave shear force, Q_w , at any position along the ship is given by:

$$Q_w = 3f_1 K_f M_{w0} / L \text{ kN (tonne - f)}$$

where

= K_f is to be taken as follows, see also Figure 2.2.2 Shear force factor K_f :

(a) Positive shear force:

- $K_f = 0$ at aft end of L
- = $+0,836f_{fH}$ between $0,2L$ and $0,3L$ from aft
- = $+0,70f_{fH}$ between $0,4L$ and $0,5L$ from aft
- = $-0,65f_{fS}$ between $0,5L$ and $0,6L$ from aft
- = $-0,91f_{fS}$ between $0,7L$ and $0,85L$ from aft
- = 0 at forward end of L

(b) Negative shear force:

- $K_f = 0$ at aft end of L
- = $+0,836f_{fS}$ between $0,15L$ and $0,3L$ from aft
- = $+0,65f_{fS}$ between $0,4L$ and $0,5L$ from aft
- = $-0,70f_{fH}$ between $0,5L$ and $0,6L$ from aft
- = $-0,91f_{fH}$ between $0,7L$ and $0,85L$ from aft
- = 0 at forward end of L

Intermediate values to be determined by linear interpolation.

f_1 , M_{w0} , f_{fS} and f_{fH} are defined in Pt 4, Ch 2, 2.4 Design vertical wave bending moments 2.4.1.

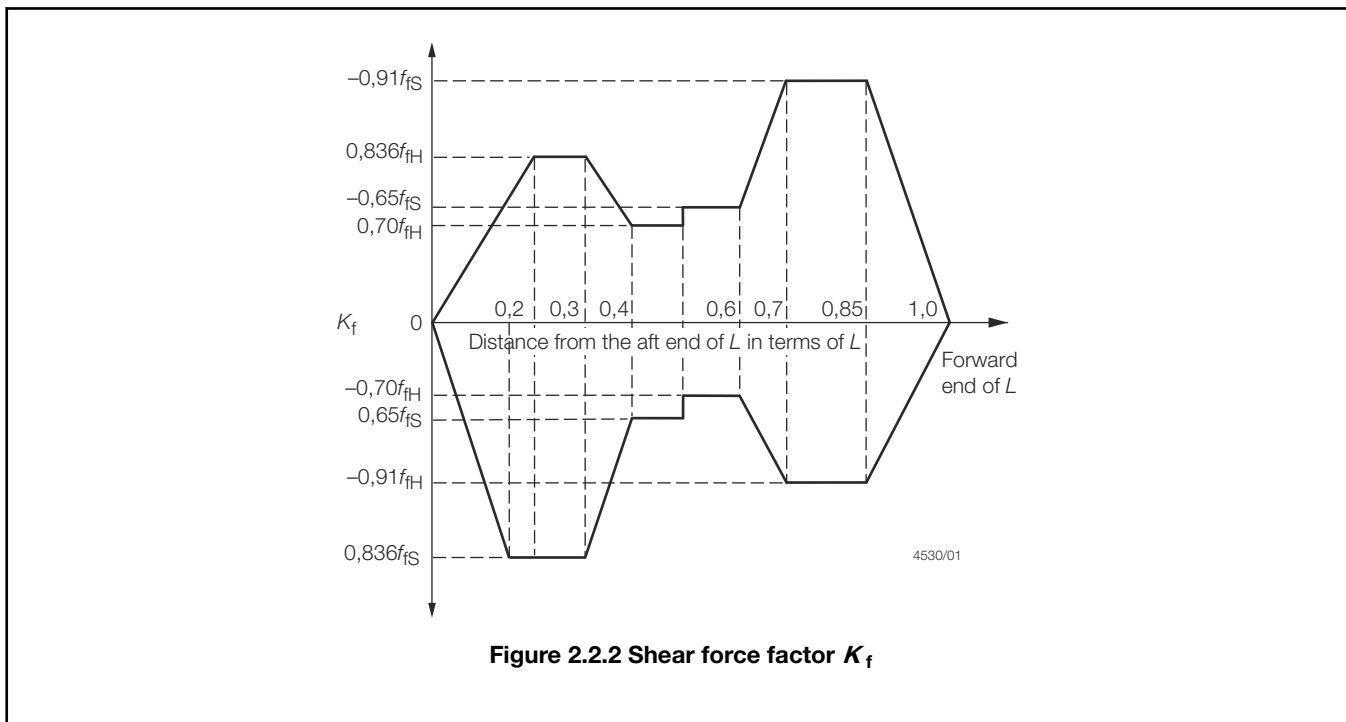

Figure 2.2.2 Shear force factor K_f

2.6 Buckling strength

2.6.1 The buckling requirements in Pt 3, Ch 4, 7 *Hull buckling strength* are to be applied to plate panels and longitudinals subject to hull girder compression and shear stresses. The design stresses are to be based on the design values of still water and wave bending moments and shear forces and are given in Pt 4, Ch 2, 2.4 *Design vertical wave bending moments* 2.4.1 and Pt 4, Ch 2, 2.5 *Design wave shear force* 2.5.1.

2.6.2 The standard deduction for corrosion, d_t , to be applied to plating and longitudinals is to be taken in accordance with Table 4.7.1 *Standard deduction for corrosion, d_t in Pt 3, Ch 4 Longitudinal Strength*.

2.6.3 The buckling factors of safety, λ , to be applied to the corrected critical buckling stress, σ_{CRB} , of plate panels and longitudinals subjected to hull girder compression are given in Table 2.2.1 *Buckling factors of safety, λ* , where the corrected critical buckling stress is to be determined in accordance with Pt 3, Ch 4, 7.3 *Elastic critical buckling stress*.

2.6.4 The shear buckling requirements of Pt 3, Ch 4, 7.3 *Elastic critical buckling stress* are to be applied.

Table 2.2.1 Buckling factors of safety, λ

Structural item	Buckling factor of safety, λ
Longitudinally effective plating	1,0
Longitudinal stiffeners	
when the buckling failure mode of the attached plating is elasto-plastic, see Note	1,1
Longitudinal stiffeners	
when the buckling failure mode of the attached plating is elastic, see Note	1,25
Note The buckling mode of failure of the attached plating is defined as follows:	

elastic	$\sigma_E \leq 0,5 \sigma_o$
elasto-plastic	$\sigma_E > 0,5 \sigma_o$
where	
Note	
σ_E	= the elastic critical buckling stress, see Pt 3, Ch 4, 7.3 Elastic critical buckling stress
σ_o	= specified minimum yield stress, in N/mm ² (kgf/mm ²).

■ **Section 3**
Deck structure

3.1 Loading

3.1.1 In general, loadings for decks should comply with the requirements of Pt 4, Ch 1 General Cargo Ships except where specified in this Section.

3.1.2 Vehicle decks for the carriage of cars, trucks, etc. are to have a loading for wheeled vehicles as specified in Pt 3, Ch 9, 3 Decks loaded by wheeled vehicles. Where vehicle decks are also used for the carriage of cargo, the loadings derived from Pt 3, Ch 9, 3 Decks loaded by wheeled vehicles are to be not less than would be required by Pt 4, Ch 1 General Cargo Ships.

3.1.3 For ferries and passenger ships classed **100A1**, the minimum design loadings for decks are not to be taken as less than those in Table 2.3.1 Design deck loadings (ferries and passenger ships only).

3.1.4 For ferries and passenger ships classed **100A1** with a specified operating area service notation, the loadings for decks in way of baggage and accommodation spaces are to be in accordance with Table 2.3.1 Design deck loadings (ferries and passenger ships only).

3.1.5 Mooring decks, afterward and forward, other than when part of the strength deck, are to comply with the requirements for forecastles, see Pt 3, Ch 8 Superstructures, Deckhouses and Bulwarks. Canopy decks or aprons protecting mooring decks are to be designed using the weather head for forecastle decks reduced by 0,3 m.

3.1.6 For movable decks, see Pt 3, Ch 9, 4 Movable decks.

3.1.7 For train decks, the minimum design loading will be specially considered.

Table 2.3.1 Design deck loadings (ferries and passenger ships only)

Deck	Design pressures P_s , in kN/m ² (tonne-f/m ²)	
	Secondary structures	Primary structures
Decks in way of accommodation and public spaces, see Note	6,38 (0,65)	3,12 (0,32)
Deck supporting baggage spaces	$3,53H_t$ ($0,36H_t$)	$3,53H_t$ ($0,36H_t$)

Decks in way of stores and refrigerated spaces	14,13 (1,44)	14,13 (1,44)
Decks in way of workshop and machinery spaces (excludes A/C machinery spaces)	18,34 (1,87)	18,34 (1,87)
Magradomes	2,45 (0,25)	2,45 (0,25)
Balconies	3,92 (0,40)	1,96 (0,20)
Weather exposed superstructure decks	2,26 (0,23)	2,26 (0,23)
Weather exposed lifeboat deck	8,44 (0,86)	8,44 (0,86)
Symbols		
H_t = 'tween deck height, in metres		
Note The design pressure, P_s , may be reduced by 12 per cent for ferries and passenger ships with a specified operating area service notation.		

Table 2.3.2 Thickness of deck plating

Deck location	Plating thickness (mm)
Accommodation and public spaces	$t = 0,008s \sqrt{k}$
Baggage handling and storage	$t = 0,009s \sqrt{k}$
Storerooms	$t = 0,01s \sqrt{k}$
Workshops and machinery spaces	$t = 0,01s \sqrt{k}$
Weather exposed lifeboat deck	$t = 0,00083s_1 \sqrt{Lk} + 2,5$
Symbols	
L, k, s as defined in Pt 4, Ch 1, 1.5 Symbols and definitions 1.5.1	
$s_1 = s$ but is not to be taken less than the smaller of $470 + \frac{L}{0,6}$ mm or 700 mm	
Note The thickness of deck plating is in no case to be less than 5,0 mm	

3.2 Deck plating

3.2.1 For ferries and passenger ships classed **100A1** the minimum thicknesses of decks are to be in accordance with *Table 2.3.2 Thickness of deck plating*.

3.2.2 For roll on-roll off cargo ships, the thickness of deck plating (other than for vehicle decks) will generally be in accordance with *Pt 4, Ch 1 General Cargo Ships*.

3.2.3 Where decks are required to resist hull girder bending, the thickness is to satisfy the requirements of *Pt 3, Ch 4, 7 Hull buckling strength*.

3.2.4 Where deck plating is required to form the effective flange of deck primary members, the thickness may need to be increased locally taking account of the compressive forces acting, see also *Pt 3, Ch 10 Welding and Structural Details, Table 10.4.1 Minimum thickness of primary members*.

3.2.5 Vehicle deck plating is to satisfy the requirements for plating loaded by wheeled vehicles as specified in *Pt 3, Ch 9, 3 Decks loaded by wheeled vehicles*. Where vehicle decks are also to be used for the carriage of cargo, the thickness of plating derived from *Pt 3, Ch 9, 3 Decks loaded by wheeled vehicles* is to be not less than would be required by *Pt 4, Ch 1, 4.2 Deck plating*.

3.2.6 The thickness of all other decks will generally be in accordance with *Pt 4, Ch 1 General Cargo Ships*.

3.3 Deck stiffening

3.3.1 For ferries, roll on-roll off cargo ships and passenger ships, the deck stiffening (other than for vehicle decks) will generally be in accordance with *Pt 4, Ch 1 General Cargo Ships*. However, in view of the complexity of some multi-deck arrangements in association with large freeboards, deck stiffening may require special consideration.

3.3.2 Vehicle deck beams and longitudinals are to have scantlings in accordance with the requirements for wheeled vehicles as specified in *Pt 3, Ch 9, 3 Decks loaded by wheeled vehicles*. Where vehicle decks are also to be used for the carriage of cargo, the scantlings derived from *Pt 3, Ch 9, 3 Decks loaded by wheeled vehicles* are to be not less than would be required by *Pt 4, Ch 1, 4.3 Deck stiffening*.

3.3.3 In multi-decked ships with high freeboards, the section modulus of deck beams and longitudinals is to be not less than the value given by *Table 2.3.3 Modulus of deck beams and longitudinals for multi-decked ships with high freeboards*.

Table 2.3.3 Modulus of deck beams and longitudinals for multi-decked ships with high freeboards

Position of beam/longitudinal	Modulus, in cm ³
Decks, excluding those for the stowage of cargo or vehicles	$Z = 0,00083 f_R P_s l_e^2 s k$ $(Z = 0,0081 f_R P_s l_e^2 s k)$ but not less than: $Z = 0,025s$
Symbols	
$l_e, s, Z,$ and k as defined in <i>Pt 4, Ch 1, 1.5 Symbols and definitions</i> P_s = deck loading, in kN/m ² (tonne-f/m ²), see <i>Table 2.3.1 Design deck loadings (ferries and passenger ships only)</i> . f_R = 1, for ships with unrestricted service f_R = 0,81 for ships with a specified operating area service notation	

3.4 Deck supporting primary structure

3.4.1 The section modulus of primary members supporting four or more point loads or a uniformly distributed load is not to be taken as less than:

$$Z = 0,673 S P_s k l_e^2 (\text{cm}^3)$$

$$(Z = 6,60 S P_s k l_e^2) (\text{cm}^3)$$

where

= l_e , S , Z , and k are as defined in Pt 4, Ch 1, 1.5 Symbols and definitions

P_s = deck design loading, in kN/m² (tonnes/m²), see Table 2.3.1 Design deck loadings (ferries and passenger ships only).

3.4.2 The moment of inertia of primary members supporting more than four point loads is not to be taken as less than:

$$I = \frac{1,85}{k} l_e Z (\text{cm}^4)$$

= Z and l_e as defined in Pt 4, Ch 2, 3.4 Deck supporting primary structure 3.4.1.

3.4.3 Scantlings of primary structure are to be verified for the following cases using direct calculation methods.

- (a) The structural support arrangement is complex either due to arrangement or loading pattern.
- (b) Large openings are incorporated in the webs of primary members.
- (c) The structure is of novel or unusual design.

The stress criteria in Table 1.4.6 Deck girders, transverses and hatch beams in Chapter 1 are to be complied with.

3.4.4 Direct calculations should be carried out in accordance with the SDA procedure relevant to the ship type.

3.4.5 Vehicle deck structure is to be of adequate strength for the upward forces imposed at fixed securing points. Local reinforcement is to be fitted as necessary.

■ Section 4 Shell envelope plating

4.1 Bottom and side shell

4.1.1 For ferries and passenger ships classed **100A1** with a specified operating area service notation the keel thickness for 0,4L amidships is to be as required by Pt 4, Ch 1, 5 Shell envelope plating. At ends, the keel thickness may be reduced by 25 per cent from the above value, but is to be not less than that of the adjacent shell plating.

4.1.2 The thickness of side shell plating above 1,6T including superstructures may require special consideration depending on the particular structural arrangement, hull vertical bending and shear stresses and position of the shell above the waterline. In no case are the shell scantlings above 1,6T to be less than the following:

(a)
$$t_{zm} = t_{shell} - (Z_m - 1,6T)(0,24 + 0,0012L)\sqrt{\frac{k s_1}{s_b}}$$

(b)
$$t_{zm} = (4 + 0,02L)\sqrt{\frac{k s_1}{s_b}}$$

(c) as required by Pt 3, Ch 8 Superstructures, Deckhouses and Bulwarks

where

t_{shell} = minimum required shell thickness above D/2 for the specific location, as calculated in Pt 4, Ch 1, 5 Shell envelope plating

t_{zm} = minimum shell thickness at Z_m

Z_m = vertical height in metres above base

= L and T as defined in Pt 3, Ch 1, 1.5 Intact stability.

= s_1 , s_b as defined in Table 5.3.1 Shell plating forward in Pt 3, Ch 5 Fore End Structure for fore end or Table 6.3.1 Shell plating aft in Pt 3, Ch 6 Aft End Structure for aft end.

4.1.3 Openings in the side shell and superstructure plating for windows and doors are to be suitably stiffened and the thickness and grade of plating in way will be specially considered.

4.1.4 For ships with broad flat counter stern sections which are liable to be subjected to large wave impact loading, the effect of wave impact loading on the plating and framing of the local shell structure is to be additionally considered, see *Pt 4, Ch 2, 4.3 Strengthening for wave impact loads* and *Pt 4, Ch 2, 5.2 Strengthening for wave impact loads*.

4.1.5 The plating and framing of the forward shell structure for ships with significant bow flare is to be additionally considered with regard to wave impact loading, see *Pt 4, Ch 2, 4.3 Strengthening for wave impact loads* and *Pt 4, Ch 2, 5.2 Strengthening for wave impact loads*.

4.1.6 The minimum thickness of the shell plating at ends and for taper is to be not less than the values given in *Table 2.4.1 End shell thickness*, and is in no case to be less than 6 mm.

4.1.7 For ferries and passenger ships classed **100A1** with a specified operating area service notation, the bottom and side shell minimum thickness at ends may be taken 20 per cent less than that required by *Table 2.4.1 End shell thickness* and *Pt 3, Ch 5 Fore End Structure* and *Pt 3, Ch 6 Aft End Structure*, but is in no case to be less than 6 mm.

Table 2.4.1 End shell thickness

Scantling length	Thickness, in mm
70 m and below	$(6,5 + 0,033L) \sqrt{\frac{ks_1}{s_b}} - 1,0$
Between 70 m and 110 m	$(6,5 + 0,033L) \sqrt{\frac{ks_1}{s_b}} - 0,5$
Over 110 m	<i>Pt 3, Ch 5 Fore End Structure</i> and <i>Pt 3, Ch 6 Aft End Structure</i>
Symbols	
<i>L</i> as defined in <i>Pt 3, Ch 1, 1.5 Intact stability</i>	
<i>s₁, s_b</i> as defined in <i>Table 5.3.1 Shell and deck plating</i> in <i>Pt 3, Ch 5 Fore End Structure</i> for fore end or <i>Table 6.3.1 Shell plating aft</i> in <i>Pt 3, Ch 6 Aft End Structure</i> for aft end	

4.2 Bow flare and wave impact pressures

4.2.1 This Section is applicable to:

- (a) bow flare region;
- (b) sides and undersides of sponsons; and
- (c) other parts of the side shell plating close to and above the design waterline that are expected to be subjected to wave impact pressures.

The wave impact pressure, P_{bf} , in kN/m² due to relative motion is to be taken as:

$$P_{bf} = 0,5 (K_{bf} V_{bf}^2 + K_{rv} H_{rv} V_{rv}^2) \text{ kN/m}^2$$

where

K_{bf} = hull form shape coefficient for wave impacts

$$= \frac{\pi}{\tan \psi} \text{ for } \psi \geq 10$$

$$= 28 (1 - \tan (2\psi)) \text{ for } \psi < 10$$

V_{bf} = wave impact velocity, in m/s, and is given by

where

$$= \sqrt{V_{\text{thbf}}^2 + 2m_1 \ln(N_{\text{bf}})} \text{ for } N_{\text{bf}} \geq 1$$

$$= 0 \text{ for } N_{\text{bf}} < 1$$

V_{thbf} = threshold velocity for wave impact, in m/s, to be taken as:

$$= \frac{\sqrt{10}}{\cos \alpha_p}$$

= $\ln()$ is the natural logarithm

N_{bf} = No. of wave impacts in a three hour period and is given by

$$= 1720 PR_{\text{bf}} \sqrt{\frac{m_1}{m_0}}$$

PR_{bf} = probability of a wave impact and is given by

$$= e^{-u}$$

$$u = \left(\frac{Z_{\text{wl}}^2}{2m_0} + \frac{V_{\text{thbf}}^2}{2m_1} \right)$$

Z_{wl} = distance of the centroid of the area of plating or stiffener above the local design waterline

m_1 = variance of the relative vertical velocity

$$= 0,25(\omega_e f_{\text{sl}} H_{\text{rm}})^2$$

m_0 = variance of the relative vertical motion

$$= 0,25 (f_{\text{sl}} H_{\text{rm}})^2$$

ω_e = effective encounter wave frequency

$$= \omega \left(1 + \frac{0,4q \omega V_{\text{sl}}}{g} \right)$$

= where

$$q = 1,0 \text{ for } \frac{x}{L} \geq 0,5$$

$$= -0,6 \text{ for } \frac{x}{L} < 0,5$$

ω = effective wave frequency based on 80 per cent ship length

$$= \sqrt{\frac{2 \pi g}{0,8L_{\text{WL}}}}$$

f_{sl} = probability level correction factor for relative vertical motion

$$= 1,0 \text{ for } C_b \leq 0,6$$

$$= 1,2 \text{ for } C_b > 0,6$$

V_{sl} = 0,515V, in m/s

K_{IV} = hull form shape coefficient for impact due to forward speed

$$= \frac{\pi}{\tan(90 - \alpha_p)} \text{ for } \alpha_p \leq 80$$

$$= 28 (1 - \tan(2(90 - \alpha_p))) \text{ for } \alpha_p > 80$$

H_{IV} = relative wave heading coefficient

where

$$= \text{for } \frac{x}{L} \geq 0,5$$

$$= 1 \text{ for } \gamma_p > 45$$

$$= \cos(45 - \gamma_p) \text{ for } \gamma_p \leq 45$$

$$= \text{for } \frac{x}{L} < 0,5$$

$$= 0$$

= The point at which the following angles are to be measured for assessment of plating and stiffeners is detailed in *Table 2.4.2 Positions at which α_p , β_p and γ_p are to be measured* :

V_{IV} = relative forward speed, in m/s

$$= 0,515V \sin \gamma_p$$

α_p = buttock angle measured in the longitudinal plane, in degrees, see *Figure 2.4.1 Bow flare and bottom slamming angles* and *Table 2.4.2 Positions at which α_p , β_p and γ_p are to be measured*

ψ = effective deadrise angle, in degrees

For $C_b > 0,6$, ψ is to be taken as the maximum of α_p and β_p , see *Figure 2.4.1 Bow flare and bottom slamming angles* and *Table 2.4.2 Positions at which α_p , β_p and γ_p are to be measured*

For $C_b \leq 0,6$, ψ is to be taken as the maximum of α_p and β

= where

$$\beta = \beta_p - 10^\circ, \text{ but is to be taken as not less than } 0^\circ$$

= NOTE

= The 10° deduction is to allow for the effects of roll motion on the impact pressures.

γ_p = waterline angle measured in the horizontal plane, in degrees, see *Figure 2.4.1 Bow flare and bottom slamming angles* and *Table 2.4.2 Positions at which α_p , β_p and γ_p are to be measured* .

= NOTE

= Where only two angles are known and are measured in orthogonal planes, the third angle may be obtained by the following expression:

$$\alpha_p = \tan^{-1} (\tan \beta_p \tan \gamma_p)$$

The relative vertical motion, H_{rm} , is to be taken as

$$H_{rm} = C_{w,\min} \left(1 + \frac{4,5}{(C_b + 0,2)} \left(\frac{X_{WL}}{L_{WL}} - x_m \right)^2 \right)$$

where

$$C_{w,\min} = \frac{C_w}{\sqrt{2k_m}}$$

C_w = a wave head in metres

$$= 0,0771 L_{WL} (C_b + 0,2)^{0,3} e^{(-0,0044 L_{WL})}$$

$$k_m = \frac{4,5(0,5 - x_m)^2}{(C_b + 0,2)}$$

x_m = $0,45 - 0,6F_n$ but is not to be less than 0,2

where

$$F_n = \frac{0,515V}{\sqrt{gL_{WL}}}$$

L_{WL} = waterline length at summer load draught

X_{WL} = longitudinal distance, in metres, measured forwards from the aft end of the L_{WL} to the location being considered

V = speed, in knots

= for $\frac{x}{L} \geq 0,5$

= is to be taken as the maximum service speed, in knots, as defined in Pt 3, Ch 1, 6 Definitions For passenger yachts not required to maintain high speeds in severe weather, the value of V may be specially considered, but is not to be taken as less than the greater of $\frac{V}{3}$ or 5 knots. Where V has been specially considered it is to be noted in the classification records as a memorandum that should state: "A design speed of ... knots has been used for the assessment of bow structure with regards to bow flare impacts. It should be noted that this speed may not be appropriate for all conditions and it is the responsibility of the Master to apply good Seamanship to minimise bow flare slamming."

= for $\frac{x}{L} < 0,5$

= 0 knots, for passenger ships

= 5 knots, for all other ship types

C_b = Rule block coefficient.

Table 2.4.2 Positions at which α_p , β_p and γ_p are to be measured

Framing system	Plating	Secondary stiffeners
Longitudinally framed	Mid-distance between longitudinals	Mid-distance between frames
Transversely framed	0,5s from the bottom edge of the plate strake or primary member	Mid-distance between primary members

4.2.2 Alternatively, P_{bf} may be derived by the direct calculations carried out in accordance with a procedure agreed by LR.

4.3 Strengthening for wave impact loads

4.3.1 The shell envelope in the forward and after portions of the hull are to be strengthened against bow flare or wave impact pressure. Typically, strengthening is to be considered over the following areas:

- over the after body in way of a flat counter stern which is close to the waterline;
- over the fore end side and bow structure above the waterline and up to the deck at side;
- other areas where the hull exhibits significant flare.

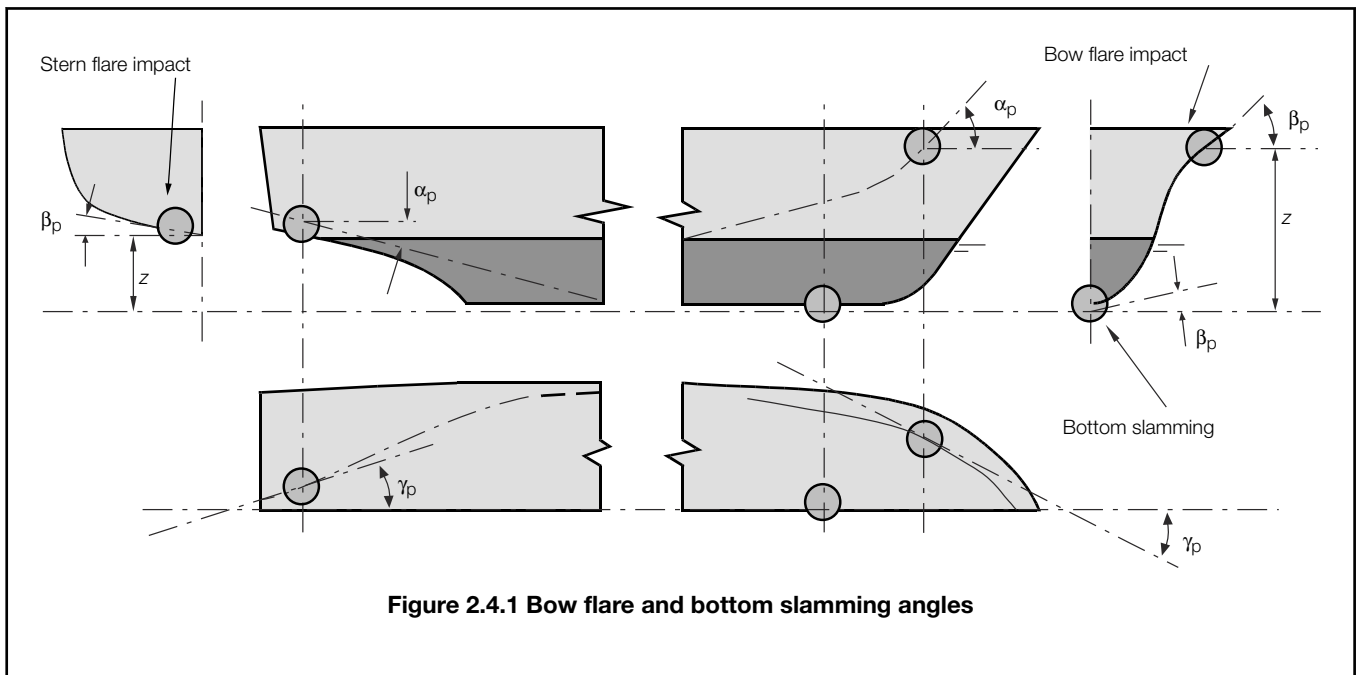

Figure 2.4.1 Bow flare and bottom slamming angles

4.3.2 The thickness of the side shell plating is to be not less than:

$$t = 3,2s_c\sqrt{kh_s}C_R \times 10^{-2} \text{ mm}$$

where

s_c = is the length of the shorter edge of a plating panel framed by primary and secondary members, see Figure 2.4.2 Chord spacing and mean chord spacing for secondary members

h_s = equivalent wave impact head, in metres

$$h_s = 0,1 P_{bf} \text{ m}$$

P_{bf} = is defined in Pt 4, Ch 2, 4.2 Bow flare and wave impact pressures 4.2.1

C_R = panel ratio factor

$$C_R = \left(\frac{l}{s_c}\right)^{0,41} \text{ but is not to be taken less than } 0,06 \text{ or greater than } 0,1$$

l = overall panel length, in metres, measured along a chord between the primary members.

4.3.3 The structural scantlings required in areas strengthened against bow flare slamming are to be tapered to meet the normal shell envelope requirements.

4.3.4 The side structure scantlings required by this Section must in no case be taken less than those required by the remaining Sections of Pt 4, Ch 2 Ferries, Roll On-Roll Off Ships and Passenger Ships.

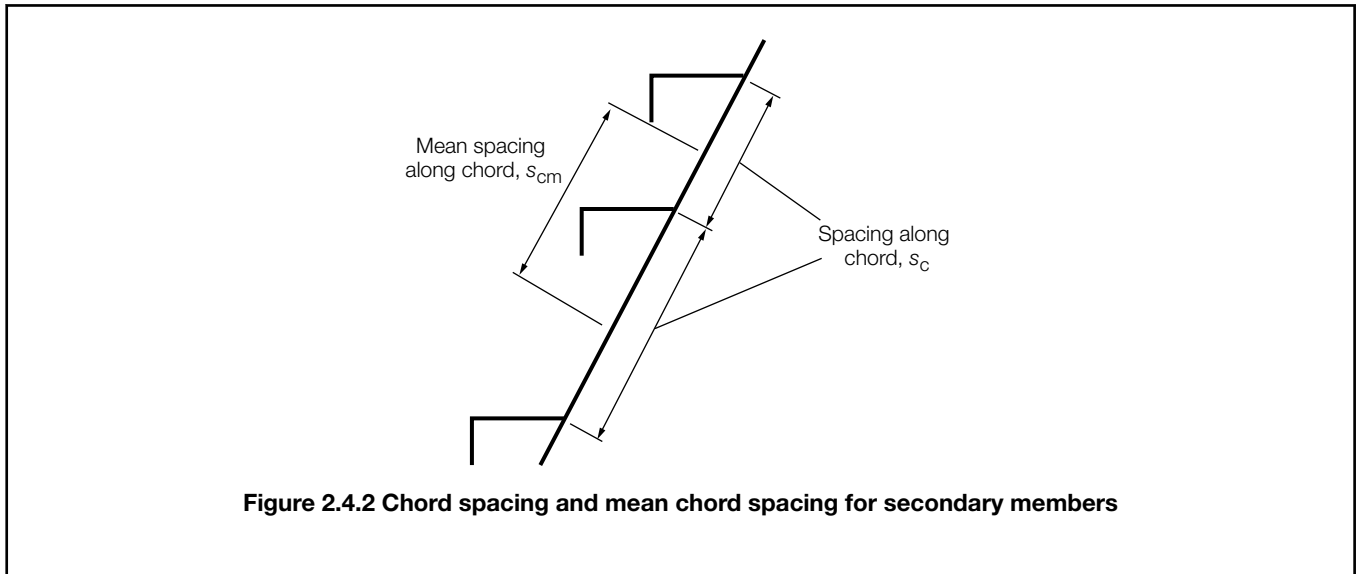

Figure 2.4.2 Chord spacing and mean chord spacing for secondary members

■ **Section 5**
Shell envelope framing

5.1 Side structure

5.1.1 The scantlings of frames, or side longitudinals, web frames or transverses, and stringers below 1,6T above base are to satisfy the requirement of Pt 4, Ch 1 General Cargo Ships and this Section, but may be required to be confirmed by direct calculation. The scantlings of these members above 1,6T from base may require special consideration on the basis of the particular structural arrangements, design deck loading, hull vertical bending stresses, and position of the member above the waterline.

5.1.2 The scantlings of side transverses supporting shell longitudinals above 1,6T are to satisfy the requirements of:

- (a) Pt 4, Ch 1, 6 Shell envelope framing, Pt 3, Ch 5, 4 Shell envelope framing and Pt 3, Ch 6, 4 Shell envelope framing.
- (b) The minimum geometric properties required in order to provide rotational constraint to the end of the deck transverse in way:

$$Z_s = \frac{0,677SkP_s L_d^3}{\left(\frac{I_d}{I_s}\right)L_s + L_d} \text{ cm}^3$$

but is not to be less than $0,339S k P_s L_d^2 \text{ cm}^3$

$$I_s \text{ is not to be less than } I_d \left(\frac{L_s}{L_d}\right) \left(\frac{Z_{dR}}{Z_d}\right) \text{ cm}^4$$

where

- P_s = deck design loading, in kN/m², see Table 2.3.1 Design deck loadings (ferries and passenger ships only)
- L_d = span of adjacent deck transverse, in metres
- Z_d = actual modulus of adjacent deck transverse, in cm³
- Z_{dR} = Rule modulus of adjacent deck transverse, in cm³
- I_d = moment of inertia of adjacent deck transverse, in cm⁴
- L_s = span of side shell transverse, in metres
- I_s = moment of inertia of side shell transverse, in cm⁴

where

S, k = as defined in *Pt 4, Ch 2, 1.5 Symbols 1.5.1*

= Due account should be taken of the shell window dimensions when determining the effective width of attached plating.

5.1.3 The required modulus of transverse main and 'tween deck frames, which may have reasonably constant convex curvature over their entire length, may be corrected for curvature as follows:

$$Z_{\min} = Z_{\text{rule}} \left(\frac{1}{\text{Cosh}\left(\frac{2\pi Y_c}{l_e}\right)} \right)^3 \text{ cm}^3$$

where

Z_{rule} = modulus requirement, in cm^3 , from *Pt 4, Ch 1 General Cargo Ships* using l_e

l_e = distance between span support points, in metres, as shown in *Figure 2.5.1 Distance between span support points and curvature*

Y_c = curvature measured from a line intersecting the end support points to the frame at mid-span, in metres, as shown in *Figure 2.5.1 Distance between span support points and curvature*

Z_{\min} = is not to be less than $0,5Z_{\text{rule}}$.

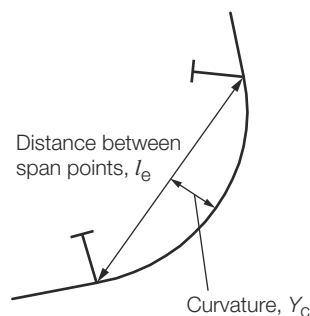

Figure 2.5.1 Distance between span support points and curvature

5.1.4 Where ramp openings are fitted adjacent to the ship's side, adequate support for the side framing is to be provided.

5.2 Strengthening for wave impact loads

5.2.1 The side structure in the forward and after portions of the hull is to be strengthened against bow flare or wave impact pressure. Typically, strengthening is to be considered over the following areas:

- over the after body in way of a flat counter stern which is close to the waterline.
- over the fore end side and bow structure above the waterline and up to the deck at side.
- other areas where the hull exhibits significant flare.

5.2.2 The scantlings of secondary stiffeners are not to be less than:

(a) Effective plastic section modulus of stiffeners:

$$Z_p = 3,75h_s s_{\text{cm}} k l_e^2 \times 10^{-3} \text{ cm}^3$$

where

h_s = wave impact head, in metres, as defined in *Pt 4, Ch 2, 4.3 Strengthening for wave impact loads 4.3.2*

where

s_{cm} = mean spacing of secondary stiffeners, in mm, measured along a chord between parallel adjacent members or equivalent supports, as shown in *Figure 2.4.2 Chord spacing and mean chord spacing for secondary members*

Other symbols are as defined in *Pt 4, Ch 2, 1.5 Symbols 1.5.2*.

(b) Web area of secondary stiffeners

$$A = 3,7 s_{cm} k h_s \left(l_e - \frac{s_{cm}}{2000} \right) \times 10^{-4} \text{ cm}^2$$

where

s_{cm} = mean spacing of secondary stiffeners, in mm, measured along a chord between parallel adjacent members or equivalent supports, as shown in *Figure 2.4.2 Chord spacing and mean chord spacing for secondary members*

h_s = wave impact head, in metres, as defined in *Pt 4, Ch 2, 4.3 Strengthening for wave impact loads 4.3.2*

Other symbols are as defined in *Pt 4, Ch 2, 1.5 Symbols 1.5.2*.

5.2.3 The effective section properties of secondary stiffeners are to be taken as:

(a) Plastic section modulus of secondary stiffeners, Z_p , is to be taken as:

$$\begin{aligned} Z_p &= 2,8 \times 10^{-4} s_{cm} t_p^2 - 10^{-3} b_f b_{fc} t_f \sin \theta_e + 5 \times \\ &= 10^{-4} (h_w^2 t_w + 2 b_f t_f h_w) \cos \theta_e \text{ cm}^3 \end{aligned}$$

where

$$\theta_e = C_o (90 - \varphi)$$

$$C_o = 1,1$$

φ = the angle between the stiffener and the side shell, in degrees

$$b_{fc} = 0,5 (b_f - t_w) \text{ for L profiles}$$

$$= 0 \text{ for flat bar and T profiles}$$

= see *Figure 4.7.1 Dimensions of longitudinals* in *Pt 3, Ch 4 Longitudinal Strength*, for bulb profiles

h_w = height of stiffener web, in mm

t_w = web thickness, in mm

b_f = breadth of flange, in mm

t_f = flange thickness, in mm

t_p = thickness of attached plating, in mm

(a) Web area of secondary stiffeners, A_s , is to be taken as:

$$A_s = 0,01 (h_w + t_p) t_w \sin \varphi \text{ cm}^2$$

5.2.4 Where the stiffener web is not perpendicular to the plating, tripping brackets have to be fitted in order to obtain adequate lateral stability.

5.2.5 The scantlings of primary members are not to be less than:

(a) Section modulus of primary members

$$Z = 2 \gamma_z k h_s q v l_e^2 \text{ cm}^3$$

(b) Web area of primary members

$$A = 0,2 \gamma_A k h_s q v l_e \text{ cm}^2$$

where

h_s = wave impact head, in metres, as defined in Pt 4, Ch 2, 4.3 Strengthening for wave impact loads 4.3.2
= and

γ_A and γ_Z are strength factors dependent on the load position

for $q < 1$ $\gamma_A = q^3 - 2q^2 + 2$ and $\gamma_Z = 3q^3 - 8q^2 + 6q$

for $q = 1$ $\gamma_A = 1$ and $\gamma_Z = 1$

$$q = \frac{u}{l_e} \text{ but } \leq 1$$

for web frames:

u = is the minimum of g_{bfv} or l_e

v = is the minimum of g_{bfh} or S_{cm}

for primary stringers:

u = is the minimum of g_{bfh} or l_e

v = is the minimum of g_{bfv} or S_{cm}

where

l_e = is the effective length of the primary member, in metres

S_{cm} = is the mean spacing between primary members along the plating, in metres, see Figure 2.5.2 Mean spacing between primary members, S_{cm} , and the extents of wave impact pressure g_{bfh} and g_{bfv}

= g_{bfv} and g_{bfh} are defined in Pt 4, Ch 2, 5.2 Strengthening for wave impact loads 5.2.6

= Other symbols are as defined in Pt 4, Ch 2, 1.5 Symbols 1.5.2.

(a) The web of the primary member is to be adequately stiffened.

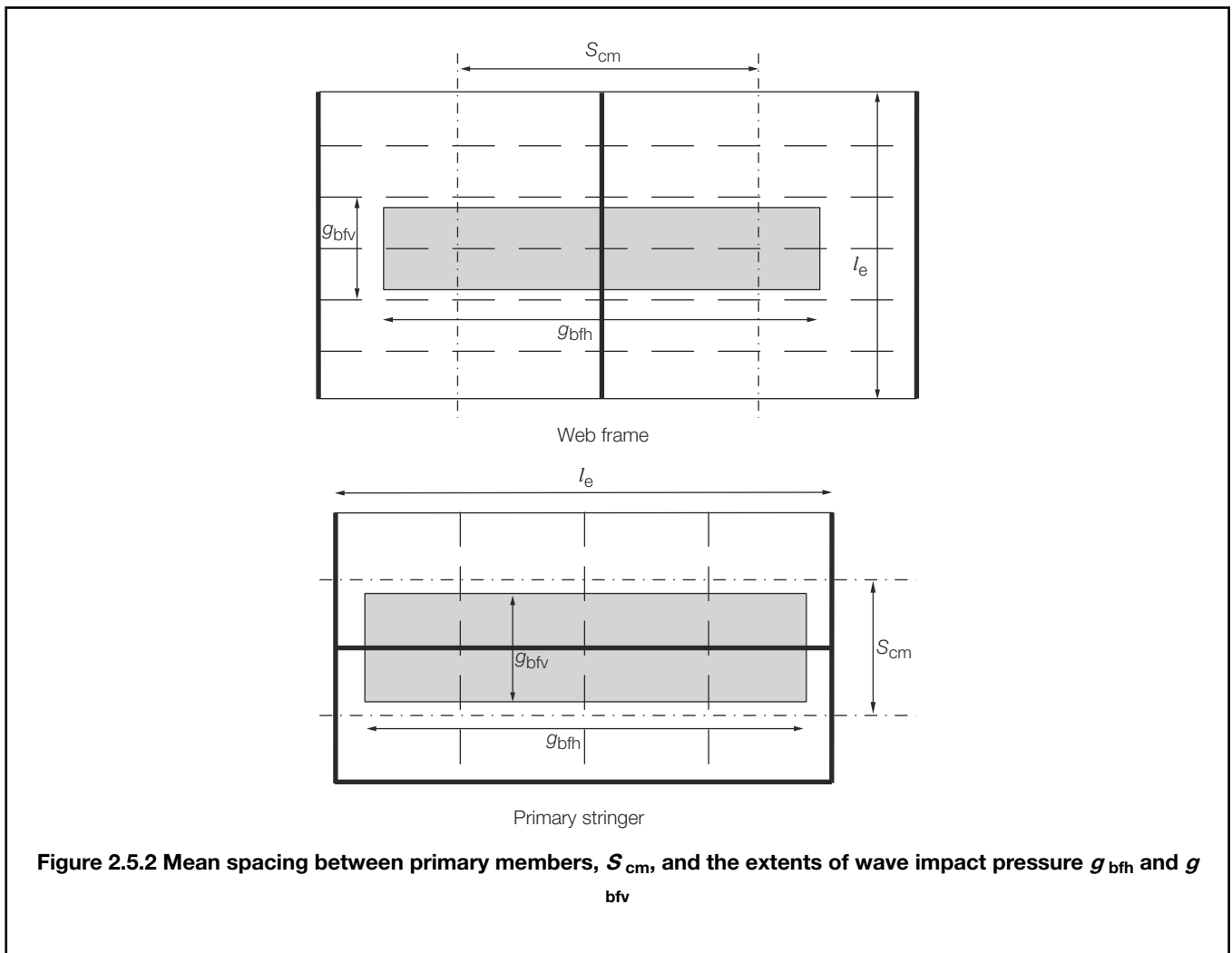

Figure 2.5.2 Mean spacing between primary members, S_{cm} , and the extents of wave impact pressure g_{bfh} and g_{bfv}

5.2.6 The extents of the wave impact pressure are to be derived as follows:

(a) the vertical extent, g_{bfv} , is to be taken as:

$$g_{bfv} = \frac{4}{\sin \psi \sqrt{8K_{bf}}} \text{ m}$$

(b) the horizontal extent, g_{bfh} , is to be taken as:

$$g_{bfh} = 4 \text{ m}$$

where

= K_{bf} and ψ are given in Pt 4, Ch 2, 4.2 Bow flare and wave impact pressures 4.2.1.

5.2.7 For primary members with cut-outs for the passage of secondary stiffeners, and which may have web stiffeners connected to the secondary stiffener, buckling checks are to be carried out to ensure that the primary member web plating and web stiffener will not buckle under the design load. The buckling procedure to be followed is given in Table 5.1.3 *Buckling procedure for primary member web plating and web stiffener* in Pt 3, Ch 5 *Fore End Structure*. Where the web stiffener is fitted with a bracket, the buckling capability of the web stiffener in way of the cut-out is to take account of the bracket. Where no web stiffener is fitted, the buckling capability of the primary member web plating is to be checked for the total load transmitted to the connection.

5.2.8 Where the angle between primary structure web and the plating is less than 70°, the effective section modulus and shear area are to take account of the non-perpendicularity.

5.2.9 The structural scantlings required in areas strengthened against bow flare slamming are to be tapered to meet the normal shell envelope requirements.

5.2.10 The side structure scantlings required by this Section must in no case be taken less than those required by the remaining Sections of *Pt 4, Ch 2 Ferries, Roll On-Roll Off Ships and Passenger Ships*.

■ Section 6 Double bottom

6.1 General

6.1.1 A double bottom is to be fitted in accordance with *Pt 4, Ch 1, 8 Double bottom structure*.

6.1.2 Where podded drive systems are to be employed, adequate floors and girders are to be arranged in order to efficiently integrate the unit into the aft structure. The adequacy of the hull structure supporting the unit is to be verified using the maximum external forces and moments stated by the manufacturer. Due account is to be taken of additional forces induced by ship motion accelerations.

6.2 Transmission of pillar loads

6.2.1 In ships where the deck centreline supports are widely spaced, transmission of the pillar loads to the double bottom structure will be specially considered, and additional reinforcement may be required if high shear and bending stresses are induced by the concentrated loads. The reinforcement should take the form of additional floors, and fore and aft girders. The final reinforcement is to be confirmed by direct calculation.

6.2.2 Where, in multi-decked passenger ships, the Rule deck loadings from *Table 2.3.1 Design deck loadings (ferries and passenger ships only)* have been used to determine the primary deck supporting structure, the cumulative pillar load P_p may be taken as:

$$P_p = \sum (b_p S_p) P_s \text{ kN}$$

where

b_p = breadth of deck supported by pillar

S_p = mean spacing between pillars

P_s = see *Table 2.3.1 Design deck loadings (ferries and passenger ships only)*.

6.2.3 Pillars are to be provided with suitable pads at their heels. Long pillars, and those terminating at the inner bottom are to be bracketed. At pillar heads, the free edges of deck primary structure face plates are to be at least 20 mm clear of the pillar head attachment weld. Where necessary, gusset plates are to be fitted at primary member intersections in way of pillars. These gussets may be applied as doublers onto the primary member face plates and should be at least equal in thickness to the pillar or the face plate, whichever is greater. Where pillars act in tension, the gussets are to be integral with the primary member face plates. The axial stress in tensile pillars is not to exceed 110/k N/mm² and full penetration welds are to be arranged in way of the end connections.

6.3 Ferries and passenger ships with a specified operating area service

6.3.1 The thickness of double bottom centre girders may be reduced by 10 per cent, and the thickness of double bottom side girders and floors may be reduced by five per cent, from the values required by *Pt 4, Ch 1, 8 Double bottom structure*, but is in no case to be less than 6 mm.

■ Section 7
Peak, watertight and deep tank bulkheads**7.1 General**

7.1.1 The scantlings of watertight and deep tank bulkheads are to comply with the requirements of *Pt 4, Ch 1 General Cargo Ships*.

7.1.2 The load head, h_4 to be used in watertight bulkhead scantlings for passenger ships is, in addition, to comply with the following:

- For watertight bulkhead plating, the distance from a point one-third of the height of the plate above its lower edge to a point 0,91 m above the bulkhead deck at side, or to the deepest intermediate/equilibrium waterline in damaged condition obtained from applicable damage stability calculations, whichever is the greater.
- For watertight bulkhead stiffeners or girders, the distance from the middle of the effective length to a point 0,91 m above the bulkhead deck at side, or to the deepest intermediate/equilibrium waterline in damaged condition obtained from applicable damage stability calculations, whichever is the greater.

7.1.3 Partial watertight bulkheads and webs fitted above the bulkhead deck which are to be included in damage stability calculations, are to be assessed as watertight, see *Pt 4, Ch 2, 7.1 General 7.1.2*.

7.2 Ferries and passenger ships with a specified operating area service

7.2.1 The thickness of bulkhead plating for peak tanks and deep tanks, other than the collision bulkhead, may be reduced by 0,5 mm, and the modulus of bulkhead stiffeners, swedges, corrugations and girders may, in general, be reduced by 20 per cent from the values required by *Pt 4, Ch 1, 9 Bulkheads*.

■ Section 8
Bow doors and inner doors**8.1 Symbols**

8.1.1 The symbols used in this Section are defined as follows:

a = vertical distance, in metres, from the bow door pivot to the centroid of the vertical projected area of bow door, see *Figure 2.8.1 Bow door (upward hinging)*

b = horizontal distance, in metres, from the bow door pivot to the centroid of the horizontal projected area of bow door, see *Figure 2.8.1 Bow door (upward hinging)*

c = horizontal distance, in metres, from bow door pivot to centre of gravity of bow door, see *Figure 2.8.1 Bow door (upward hinging)*

d = vertical distance, in metres, from bow door pivot to the centre of gravity of the bow door, see *Figure 2.8.1 Bow door (upward hinging)*

h = height of the door, in metres, between the levels of the bottom of the door and the upper deck or between the bottom of the door and the top of the door, whichever is the lesser, see *Figure 2.8.2 Definition of α and β*

k = material factor (see *Pt 3, Ch 2, 1.2 Steel*), but is not to be taken less than 0,72 unless demonstrated otherwise by a direct strength analysis with regard to relevant modes of failure

l = projected length, in metres, of the door at a height of $\frac{h}{2}$ above the bottom of the door, see *Figure 2.8.2 Definition of α and β*

w = width of bow door at half height, in metres

A_z = area, in m^2 , of the horizontal projection of the bow door, between the bottom of the door and the top of the upper deck bulwark, or between the bottom of the door and the top of the door, including the bulwark, where it is part of the door, whichever is the lesser, see *Figure 2.8.1 Bow door (upward hinging)*. Where the flare angle of the bulwark is at least 15 degrees less than the flare angle of the adjacent shell plating, the height from the bottom of the door may be measured to the upper deck or to the top of the door, whichever is the lesser

A_s = area of stiffener web, in cm^2

A_x = area, in m^2 , of the transverse vertical projection of the bow door, between the bottom of the door and the top of the door or between the bottom of the door and the upper deck bulwark, or between the bottom of the door and the top of the door, including the bulwark, where it is part of the door, whichever is the lesser, see *Figure 2.8.1 Bow door (upward hinging)* Where the flare angle of the bulwark is at least 15 degrees less than the flare angle of the adjacent shell plating, the height from the bottom of the door may be measured to the upper deck or to the top of the door, whichever is lesser. In determining the height from the bottom of the door to the upper deck or to the top of the door, the bulwark is to be excluded

A_y = area, in m^2 , of the longitudinal vertical projection of the bow door, between the bottom of the door and the top of the upper deck bulwark, or between the bottom of the door and the top of the door, including the bulwark, where it is part of the door, whichever is the lesser, see *Figure 2.8.1 Bow door (upward hinging)* Where the flare angle of the bulwark is at least 15 degrees less than the flare angle of the adjacent shell plating, the height from the bottom of the door may be measured to the upper deck or to the top of the door, whichever is the lesser

W = weight of bow visor, in tonnes

q = distance, in metres, from the centroid of the hydrostatic head profile, to the top of the cargo space

C_H = 0,0125L where $L < 80$ m
= 1,0 where $L \geq 80$ m

L = length of ship, but need not be taken greater than 200 m

V = as defined in *Pt 4, Ch 2, 1.5 Symbols 1.5.1*

λ = coefficient depending on the area where the ship is intended to be operated
= 1,0 for sea-going ships
= 0,8 for ships operated in coastal waters
= 0,5 for ships operated in sheltered waters

σ = bending stress, in N/mm^2 (kgf/mm^2)

σ_e = equivalent stress, in N/mm^2 (kgf/mm^2)
= $\sqrt{\sigma^2 + 3\tau^2}$

σ_y = yield stress of the bearing material, in N/mm^2 (kgf/mm^2)

τ = shear stress, in N/mm^2 (kgf/mm^2).

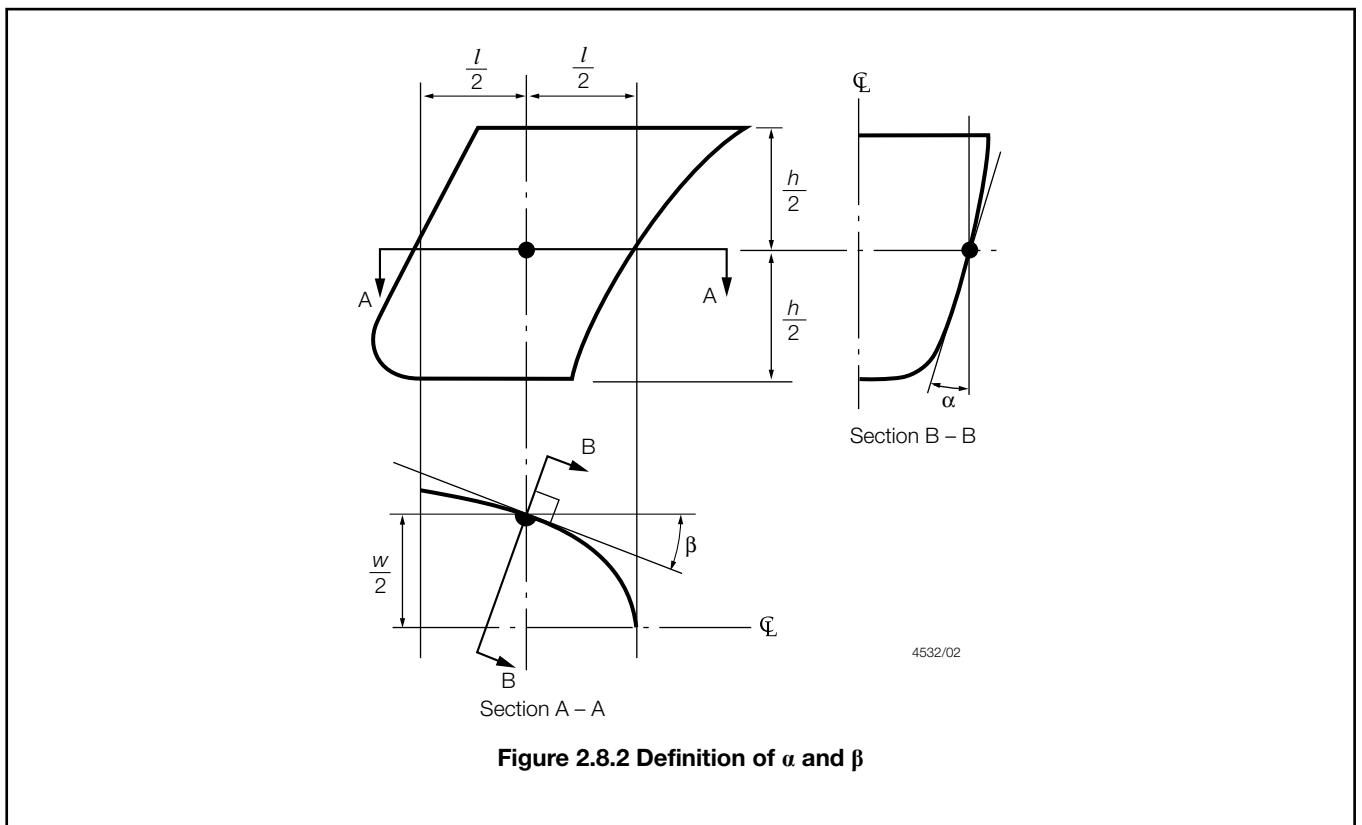
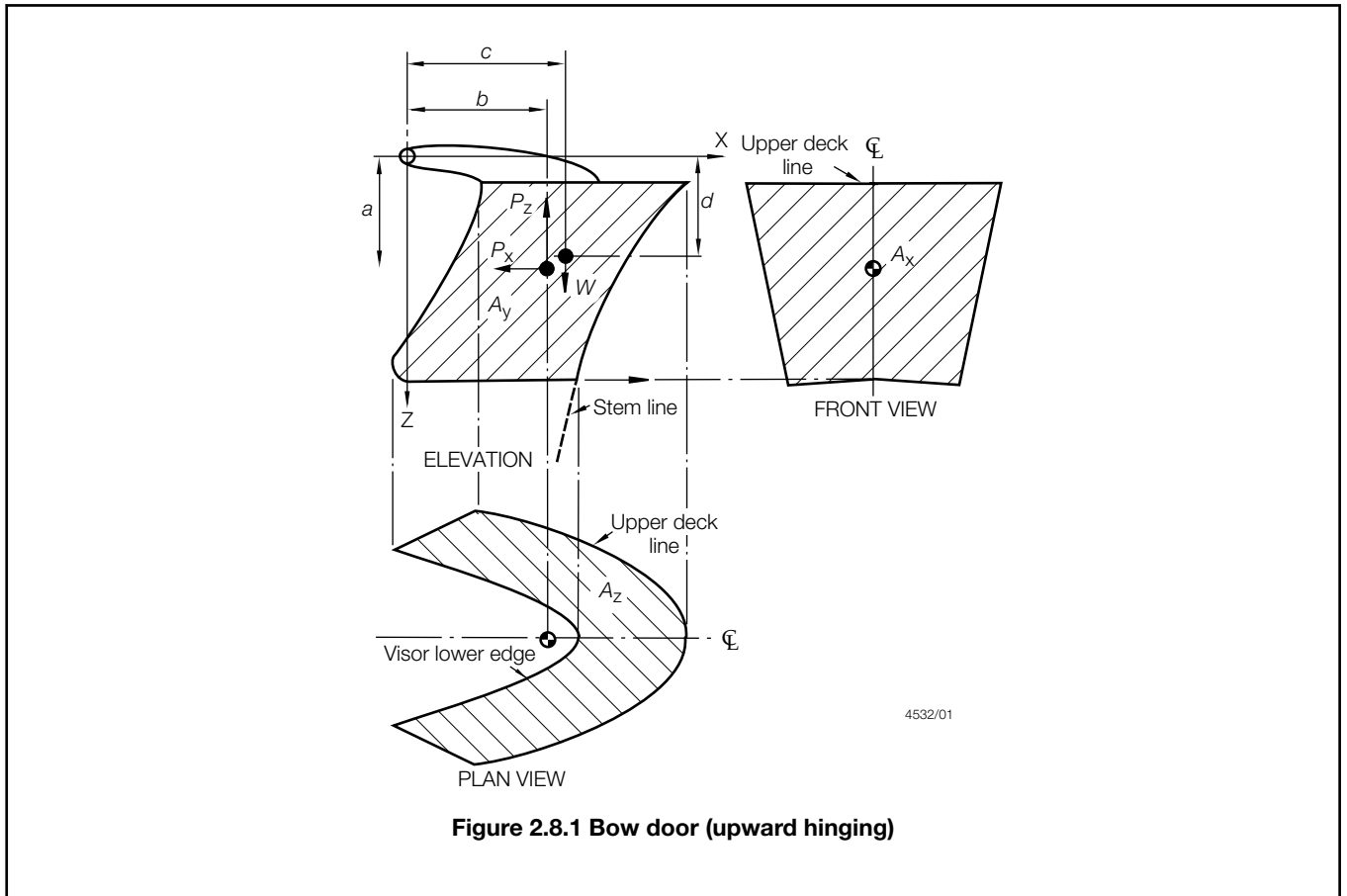

8.2 General

8.2.1 Bow doors are defined by the following types:

- (a) Visor doors opened by rotating upwards and outwards about a horizontal axis through two or more hinges located near the top of the door and connected to the primary structure of the door by longitudinally arranged lifting arms.
- (b) Side-opening doors opened either by rotating outwards about a vertical axis through two or more hinges located near the outbound edges or by horizontal translation by means of linking arms arranged with pivoted attachments to the door and the ship. It is expected that side-opening bow doors will be arranged in pairs.

Other bow door types will be specially considered.

8.2.2 Bow doors are to be situated above the freeboard deck. A watertight recess in the freeboard deck located forward of the collision bulkhead and above the deepest waterline, fitted for arrangement of ramps or other related mechanical devices, may be regarded as a part of the freeboard deck for the purpose of this requirement.

8.2.3 Where bow doors lead to a complete or long forward enclosed superstructure, or to a long non-enclosed superstructure which is fitted to attain minimum bow height equivalence, an inner door is to be fitted. The inner door is to be part of the collision bulkhead. Where a sloping vehicle ramp forming the collision bulkhead above the freeboard deck is arranged, the inner door may be omitted if the ramp is weathertight over its complete length and fulfils the requirements of *Pt 3, Ch 3 Structural Design* concerning the position of the collision bulkhead.

8.2.4 Bow doors are to be fitted with arrangement for ensuring weathertight sealing, such as gaskets, and to give effective protection to inner doors.

8.2.5 Inner doors forming part of the collision bulkhead are to be watertight over the full height of the cargo space and arranged with fixed sealing supports on the aft side of the doors.

8.2.6 Bow doors and inner doors are to be arranged so as to preclude the possibility of the bow door causing structural damage to the inner door or to the collision bulkhead in the case of damage to or detachment of the bow door. If this is not possible, a second separate inner weathertight door, complying with *Pt 4, Ch 2, 8.2 General 8.2.5*, is to be installed.

8.2.7 The requirements for inner doors are based on the assumption that vehicles and cargo are effectively lashed and secured against movement from the stowed position.

8.2.8 For ships complying with the requirements of this Section, the securing, supporting and locking devices are defined as follows:

- (a) A securing device is used to keep the door closed by preventing it from rotating about its hinges.
- (b) A supporting device is used to transmit external and internal loads from the door to a securing device and from the securing device to the ship's structure, or a device other than a securing device, such as a hinge, stopper or other fixed device, that transmits loads from the door to the ship's structure.
- (c) A locking device locks a securing device in the closed position.

8.2.9 The scantlings and arrangements of side shell and stern doors are to be in accordance with the requirements of *Pt 3, Ch 11, 8 Side and stern doors and other shell openings*.

8.3 Scantlings

8.3.1 The strength of the bow door is to be equivalent to the surrounding structure, as given in *Pt 3, Ch 5, 6 Fore peak structure*.

8.3.2 For bow doors, including bulwark, of unusual form or proportions, the areas and angles used for the determination of design values of external forces are to be specially considered.

8.3.3 Bow doors of the visor or hinged opening type are to be adequately stiffened, and means are to be provided to prevent lateral or vertical movement of the doors when closed. Care is to be taken to ensure that adequate strength is provided in the connections of the hinge or linking arms to the door structure and to the ship structure.

8.3.4 The thickness of the bow door plating is not to be less than the side shell plating calculated with the door stiffener spacing, and in no case to be less than the minimum shell plate end thickness or forecastle side thickness as appropriate.

8.3.5 The section modulus of horizontal or vertical stiffeners is not to be less than required for end framing. Consideration is to be given, where necessary, to differences in fixity between ship frames and bow door stiffeners.

8.3.6 The stiffener webs are to have a net sectional area not less than:

$$A_s = \frac{10Q}{\tau} \text{ cm}^2$$

τ is to be taken as $\frac{100}{k} \text{ N/mm}^2 \left(\frac{10,2}{k} \text{ kgf/mm}^2 \right)$

where

Q = shear force, in kN (tonne-f) calculated using the uniformly distributed external sea pressure, p_e , defined in Pt 4, Ch 2, 8.6 Design of securing and supporting devices 8.6.1

8.3.7 Bow door secondary stiffeners are to be supported by primary members constituting the main stiffening elements of the door.

8.3.8 The scantlings of such primary members are to be based on direct strength calculations. Normally, formulae for simple beam theory may be applied to determine the bending stress. Members are to be considered to have simply supported end connections. The design load, P_e , is the uniformly distributed external sea pressure. The formulae for P_e given in Pt 4, Ch 2, 8.6 Design of securing and supporting devices 8.6.1, may be used with α and β defined as:

α = flare angle, in degrees, generally to be measured normal to the shell between the vertical axis and the vertical tangent to the outer shell of the door measured at the point on the bow door, one half of the projected length ($l/2$) aft of the stern line on the plane at the half height of the door ($h/2$) (see Figure 2.8.2 Definition of α and β)

β = entry angle, in degrees, generally to be measured on the outer shell of the door between the longitudinal axis and the waterplane tangent measured at the point on the bow door, one half of the projected length ($l/2$) aft of the stem line on the plane at the half height of the door ($h/2$) (see Figure 2.8.2 Definition of α and β)

The permissible stresses are as follows:

$$\tau = \frac{80}{k} \text{ N/mm}^2 \left(\frac{8,2}{k} \text{ kgf/mm}^2 \right)$$

$$\sigma = \frac{120}{k} \text{ N/mm}^2 \left(\frac{12,2}{k} \text{ kgf/mm}^2 \right)$$

$$\sigma_e = \frac{150}{k} \text{ N/mm}^2 \left(\frac{15,3}{k} \text{ kgf/mm}^2 \right)$$

8.3.9 The webs of primary members are to be adequately stiffened, preferably in a direction perpendicular to the shell plating.

8.3.10 The primary members of the bow doors and hull structure in way are to have sufficient stiffness to ensure the integrity of the boundary support of the doors.

8.3.11 All load transmitting elements in the design load path, from door through securing arrangements and supporting devices into the ship structure, including welded connections, are to be to the same strength standard. These elements include pins, supporting brackets and back-up brackets. Where cut-outs are made in the supporting structure, the strength and stiffness will be specially considered.

8.3.12 For bow doors and inner doors, the distribution of forces acting on the securing devices and the supporting devices is to be supported by direct calculations taking into account the flexibility of the structure and the actual position and stiffness of the supports.

8.3.13 The buckling strength of primary members is to be specially considered.

8.4 Vehicle ramps

8.4.1 Where doors also serve as vehicle ramps, the scantlings are to be not less than would be required by Pt 4, Ch 2, 3.2 Deck plating 3.2.2 and Pt 4, Ch 2, 3.3 Deck stiffening 3.3.2 and where they form part of the collision bulkhead the arrangement is to be in accordance with Pt 3, Ch 3, 4.5 Watertight recesses, flats and loading ramps.

8.5 Arrangements for the closing, securing and supporting of doors

8.5.1 Bow doors are to be fitted with adequate means of closing, securing and supporting so as to be commensurate with the strength and stiffness of the surrounding structure. The hull supporting structure in way of the bow doors is to be suitable for the same design loads and design stresses as the securing and supporting devices. Where packing is required, the packing

material is to be of a comparatively soft type, and the supporting forces are to be carried by the steel structure only. Maximum design clearance between securing and supporting devices is not to exceed 3 mm.

8.5.2 Securing devices are to be simple to operate and easily accessible. They are to be of a design approved by LR for the intended purpose.

8.5.3 Securing devices are to be equipped with positive locking arrangements. Arrangements are to be such that the devices are retained in the closed position within design limits of inclination, vibration and other motion-induced loads and in the event of loss of any actuating power supply.

8.5.4 Systems for door opening/closing and securing/locking are to be interlocked in such a way that they can only operate in a proper sequence. Hydraulic systems are to comply with *Pt 5, Ch 14, 9 Hydraulic systems*.

8.5.5 Means are to be provided to enable the bow doors to be mechanically fixed in the open position taking into account the self-weight of the door and a minimum wind pressure of 1,5 kN/m² (0,153 tonne-f/m²) acting on the maximum projected area in the open position.

8.5.6 The spacing for side and top cleats should not exceed 2,5 m and there should be cleats positioned as close to the corners as practicable. Alternative arrangements for ensuring weathertight sealing will be specially considered.

8.5.7 Control and monitoring arrangements are to comply with *Pt 6, Ch 2, 19 Ship safety systems*.

8.6 Design of securing and supporting devices

8.6.1 The external design forces for securing devices, supporting devices and surrounding structure are to be taken not less than P , taking the direction of the pressure into account:

$$P_x = A_x p_e$$

$$P_y = A_y p_e$$

$$P_z = A_z p_e$$

where

p_e = external sea pressure, not to be taken less than:

(a) For bow doors:

$$\begin{aligned} p_e &= 0,8 (0,15V + 0,6 \sqrt{L})^2 \text{ kN/m}^2 \\ &= (0,082 (0,15V + 0,6 \sqrt{L})^2 \text{ tonne-f/m}^2) \end{aligned}$$

or

$$p_e = 2,75\lambda C_H (0,22 + 0,15 \tan \alpha) (0,4V \sin \beta + 0,6 \sqrt{L})^2 \text{ kN/m}^2$$

or

$$= (0,28\lambda C_H (0,22 + 0,15 \tan \alpha) (0,4V \sin \beta + 0,6 \sqrt{L})^2 \text{ tonne-f/m}^2)$$

whichever is the greater.

(b) For inner doors:

$$\begin{aligned} p_e &= 0,45L \text{ kN/m}^2 \\ &= (0,046L \text{ tonne-f/m}^2) \end{aligned}$$

or

$$\begin{aligned} p_e &= 10q \text{ kN/m}^2 \\ &= (1,02q \text{ tonne-f/m}^2) \end{aligned}$$

whichever is the greater

The symbols are as defined in *Pt 4, Ch 2, 8.1 Symbols 8.1.1*.

8.6.2 The inner door internal design pressure, considered for the scantlings of securing devices, is not to be less than 25 kN/m² (2,5 tonne-f/m²).

8.6.3 For visor doors, the pivot arrangement is to be such that the visor is self-closing under external loads. The closing moment, M_c , is to be taken as:

$$M_c = P_x a + 10Wc - P_z b \text{ kN m}$$

$$(P_x a + 1,02Wc - P_z b \text{ tonne - fm})$$

but is not to be less than:

$$M_c = 10Wc + 0,1\sqrt{(a^2 + b^2)(P_x^2 + P_z^2)} \text{ kN m}$$

$$(1,02Wc + 0,1\sqrt{(a^2 + b^2)(P_x^2 + P_z^2)} \text{ tonne - fm})$$

8.6.4 For visor doors, two securing devices are to be provided at the lower part of the door, each capable of providing the full reaction force required to prevent opening of the door within the permissible stresses given in *Pt 4, Ch 2, 8.6 Design of securing and supporting devices 8.6.7*. The opening moment M_o , to be balanced by this reaction force, is to be taken as not less than:

$$M_o = 10Wd + 5A_x a \text{ kN m}$$

$$(1,02Wd + 0,15A_x a \text{ tonne - fm})$$

8.6.5 For visor type doors, the securing and supporting devices, excluding hinges, are to be capable of resisting the vertical design force ($P_z - 10W$) kN ($(P_z - 1,02W)$ tonne-f), within the permissible stresses given in *Pt 4, Ch 2, 8.6 Design of securing and supporting devices 8.6.7*.

8.6.6 For side-opening doors, securing devices are to be provided such that in the event of a failure of any single securing device the remainder are capable of providing the full reaction force required to prevent the opening of the door. The permissible stresses given in *Pt 4, Ch 2, 8.6 Design of securing and supporting devices 8.6.7* are not to be exceeded. The opening moment about the hinges to be balanced by this reaction force is not to be less than that calculated when the following loads are applied:

- (a) An internal pressure of 5 kN/m² (0,51 tonne-f/m²).
- (b) A force of 10W kN (1,02W tonne-f) acting forward at the centroid of mass.

8.6.7 Securing devices and supporting devices are to be designed to withstand the forces given above using the following permissible stresses:

$$\tau = \frac{80}{k} \text{N/mm}^2 \left(\frac{8,2}{k} \text{kgf/mm}^2 \right)$$

$$\sigma = \frac{120}{k} \text{N/mm}^2 \left(\frac{12,2}{k} \text{kgf/mm}^2 \right)$$

$$\sigma_e = \frac{150}{k} \text{N/mm}^2 \left(\frac{15,3}{k} \text{kgf/mm}^2 \right)$$

8.6.8 The arrangement of securing and supporting devices is to be such that threaded bolts are not to carry support forces. The maximum tensile stress in way of threads of bolts, not carrying support forces, is not to exceed:

$$\frac{125}{k} \text{N/mm}^2 \left(\frac{12,7}{k} \text{kgf/mm}^2 \right)$$

8.6.9 For steel to steel bearings in securing and supporting devices, the nominal bearing pressure is not to exceed $0,8\sigma_y$. For other bearing materials, the permissible bearing pressure is to be determined according to the manufacturer's specification. The nominal bearing pressure is to be calculated by dividing the design force by the projected bearing area.

8.6.10 The reaction forces to be applied to the effective securing and supporting devices are to be determined from the combination of external loads defined in *Table 2.8.1 Combination of external loads*.

Table 2.8.1 Combination of external loads

Bow door type	Combination of external loads	
	Case 1 (Head seas)	Case 2 (Quarterming seas)
Visor doors, see Notes 1 and 2	P_x and P_z see Note 3	$0,7P_y$ acting on each side separately, together with $0,7P_x$ and $0,7P_z$
Side opening, see Notes 1 and 2	P_x , P_y and P_z acting on both doors, see Note 3	$0,7P_x$ and $0,7P_z$ acting on both doors and $0,7P_y$ acting on each door separately
<p>Note 1. P_x, P_y and P_z are defined in Pt 4, Ch 2, 8.6 Design of securing and supporting devices 8.6.1. These forces are to be applied at the centroid of the projected areas.</p> <p>Note 2. The self-weight of the door is to be included in the combination of external loads.</p> <p>Note 3. The Case 1 forces are generally to give rise to a zero moment about the transverse axis through the centroid of area A_x, see Figure 2.8.1 Bow door (upward hinging).</p>		

8.6.11 The distribution of the reaction forces acting on the securing and supporting devices is to be supported by direct calculations taking into account the flexibility of the hull structure and the actual position and stiffness of the supports. Small and/or flexible devices, such as cleats, intended to provide load compression of the packing material are not to be included in these calculations.

8.6.12 The hinge or linking arms of a bow door and its supports are to be designed for the static and dynamic opening forces. A minimum wind pressure of 1,5 kN/m² (0,153 tonne-f/m²), acting on the transverse projected area of the door is to be taken into account.

8.6.13 For side-opening doors, supporting devices are to be provided in way of girder ends at the closing of the two doors to prevent one side shifting towards the other under the effect of asymmetrical pressure. A typical arrangement is shown in Figure 2.8.3 Typical supporting device between doors.

8.6.14 Inner doors are to be gasketed and weathertight.

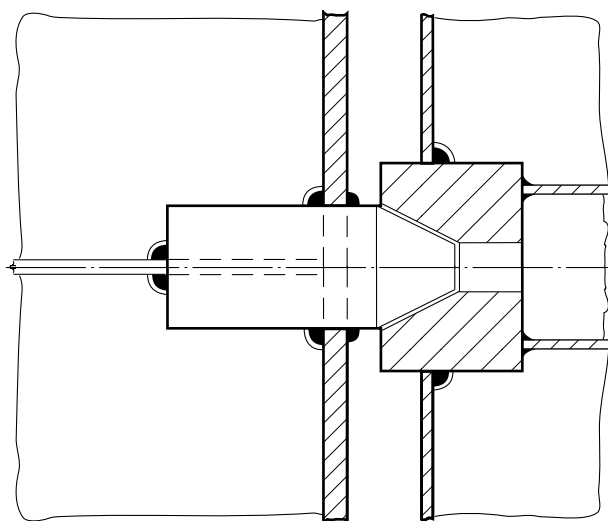

Figure 2.8.3 Typical supporting device between doors

8.6.15 Only the active supporting and securing devices having an effective stiffness in the relevant direction are to be included and considered to calculate the reaction forces acting on the devices.

8.6.16 The number of securing and supporting devices is to be the minimum practicable whilst complying with *Pt 4, Ch 2, 8.6 Design of securing and supporting devices 8.6.4* and *Pt 4, Ch 2, 8.6 Design of securing and supporting devices 8.6.17* and taking account of the available space for adequate support in the hull structure.

8.6.17 The arrangement of securing devices and supporting devices in way of these securing devices is to be designed with redundancy so that in the event of failure of any single securing or supporting device the remaining devices are capable of withstanding the reaction forces, resulting from the external loads defined in *Table 2.8.1 Combination of external loads*, without exceeding, by more than 20 per cent, the permissible stresses as defined in *Pt 4, Ch 2, 8.6 Design of securing and supporting devices 8.6.7*.

8.7 Operating and Maintenance Manual

8.7.1 An Operating and Maintenance Manual for the bow doors and inner doors is to be provided on board and is to contain the following information:

(a) main particulars and design drawings,

- special safety precautions;
- details of vessel;
- equipment and design loading for ramps;
- key plan of equipment for doors and ramps;
- manufacturers' recommended testing for equipment; and
- a description of the equipment for:

bow doors;

inner bow doors;

bow ramp/doors;

side doors;

stern doors;

central power pack;

bridge panel;

ramps leading down from the main deck;

engine control room panel.

(b) service conditions:

- limiting heel and trim of the ship for loading/unloading;
- limiting heel and trim for door operations;
- operating instructions for doors and ramps; and
- emergency operating instructions for doors and ramps.

(c) maintenance:

- schedule and extent of maintenance;
- troubleshooting and acceptable clearances; and
- manufacturers' maintenance procedures.

(d) register of inspections, including inspection of locking, securing and supporting devices, repairs and renewals.

This Manual is to be submitted for approval, and is to contain a note recommending that recorded inspections of the door supporting and securing devices be carried out by the ship's staff at monthly intervals or following incidents that could result in damage, including heavy weather or contact in the region of the doors. Any damages recorded during such inspections are to be reported to LR.

8.7.2 Documented operating procedures for closing and securing the bow doors and inner doors are to be kept on board and posted at an appropriate place.

■ **Section 9**
Subdivision structure on vehicle deck

9.1 General

9.1.1 The requirements of this Section cover subdivision structure fitted on the vehicle deck(s) of roll on-roll off passenger ships. Subdivision structure includes partition doors, bulkheads and longitudinal casings.

9.1.2 Where a ship is provided with subdivision structure that complies with the requirements of this Section, the ship will be eligible to be assigned the descriptive note **SSDS** which will be entered in column 6 of the *Register Book*.

9.1.3 The fitting of subdivision structure on the vehicle deck(s) forms one option to mitigate the stability-reducing effects of water on the vehicle deck(s) after damage. Such measures may be required by the National Administration with whom the ship is registered and/or by the National Administration within whose territorial jurisdiction the ship is intended to operate, for example see The Stockholm Agreement.

9.2 Design loads

9.2.1 For calculation of the design loads, an equivalent depth of water on the first vehicle deck above the design waterline, d , in metres, is to be derived in accordance with the requirements of the National Administration, see *Pt 4, Ch 2, 9.1 General 9.1.3*

9.2.2 It is assumed that vehicles and cargo are effectively lashed and secured to prevent movement from the stowed position.

9.2.3 The design heads (see *Figure 2.9.1 Design heads for different locations in compartment*) are not to be taken less than the greater of 0,5 m and:

(a) For transverse structure more than 1,5 m away from the longitudinal boundaries of the compartment:

$$h_T = 1,4\sqrt{L_c d K} \text{ in metres, for } z < 1$$

$$= 1,4\sqrt{L_c d K} \left(1 - \frac{(z-1)}{1,4\sqrt{L_c d K} - 1} \right) \text{ in metres, for } z \geq 1$$

Symbols are as defined in *Pt 4, Ch 2, 9.2 Design loads 9.2.4*.

(b) For longitudinal structure more than $L \sqrt{6}$ away from the transverse boundaries of the compartment:

$$h_L = \sqrt{B_c d} \text{ in metres, for } z < 1$$

$$= \sqrt{B_c d} \left(1 - \frac{(z-1)}{(1,4\sqrt{B_c d} - 1)} \right) \text{ in metres, for } z \geq 1$$

Symbols are as defined in *Pt 4, Ch 2, 9.2 Design loads 9.2.4*.

(c) For structure elsewhere:

$$h_c = \frac{L_c K}{2} + \sqrt{R} \text{ in metres, for } z < 1$$

$$= \left(\frac{L_c K}{2} + \sqrt{R} \right) \left(1 - \frac{(z-1)}{1,4 \left(\frac{L_c K}{2} + R \right) - 1} \right) \text{ in metres, for } z \geq 1$$

Symbols are as defined in *Pt 4, Ch 2, 9.2 Design loads 9.2.4*.

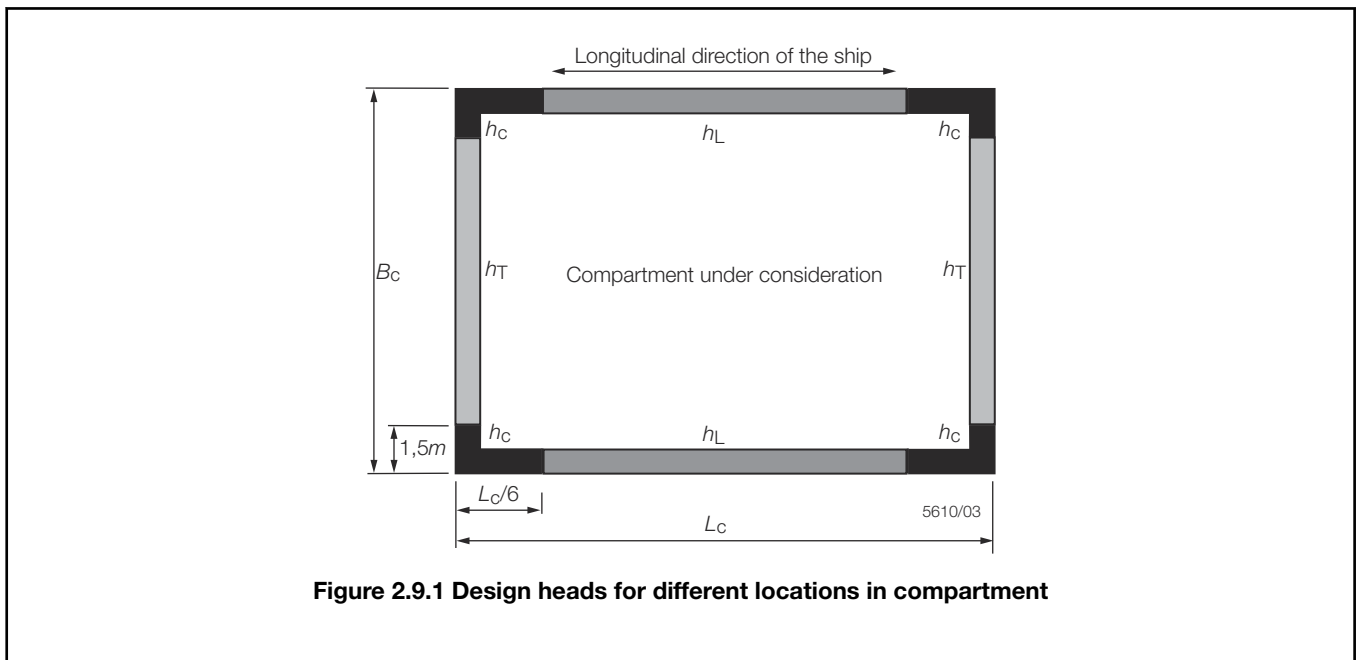

Figure 2.9.1 Design heads for different locations in compartment

9.2.4 Symbols, as used in Pt 4, Ch 2, 9.2 Design loads 9.2.3, are defined as follows:

d = equivalent depth of water on the vehicle deck, in metres, in the upright condition taking into account the volume of flooded and accumulated water on the vehicle deck calculated in accordance with the requirements of the National Administration, see Pt 4, Ch 2, 9.1 General 9.1.3 and Pt 4, Ch 2, 9.2 Design loads 9.2.1

z = vertical distance, between the point under consideration and the flooded vehicle deck, in metres. For plate panels the point under consideration is to be taken as one third of the panel height above its lower edge. For stiffeners the point under consideration is to be taken as the midspan of the effective length

B_c = breadth of compartment, in metres, see Figure 2.9.1 Design heads for different locations in compartment

K = $0,21 e^{(-0,0033L_{pp})}$ and need not exceed 0,14

L_c = length of compartment, in metres, see Figure 2.9.1 Design heads for different locations in compartment

R = $B_c d - \frac{L_c^2 K^2}{12}$ and is not to be taken less than 0

e = base of natural logarithms, 2,7183

L_{pp} = as defined in Pt 3, Ch 1, 6 Definitions

9.2.5 The design heads calculated in Pt 4, Ch 2, 9.2 Design loads 9.2.3 are based on the ship being in the upright condition. Where the actual damaged floating position is specified, the design heads will be specially considered taking this into account.

9.2.6 The subdivision structure, and access doors within the subdivision structure, are to be capable of withstanding the design loading applied from the side of the compartment under consideration.

9.2.7 Consideration will be given to the use of design heads agreed by the National Administration.

9.3 Height of subdivision structure

9.3.1 The height of the subdivision structure, H_D , is not to be less than:

- 4m, or

- $8d$, but not less than 2,2 m, or
 - the height between the vehicle deck under consideration and the underside of the next watertight deck above,
- whichever is the lesser.

where

d = is defined in Pt 4, Ch 2, 9.2 Design loads 9.2.4.

9.3.2 For special arrangements, such as hanging car decks or wide side casings, other subdivision structure heights may be accepted on the basis of detailed model tests in the flooded conditions under investigation by the National Administration.

9.4 Material

9.4.1 Where materials other than steel are used, the scantlings are to be specially considered.

9.5 Scantlings of subdivision structure other than doors

9.5.1 The minimum scantlings of subdivision bulkheads and casings are to be derived in accordance with Table 1.9.1 *Watertight and deep tank bulkhead scantlings* for watertight bulkheads, where h_4 is to be substituted by either of h_T , h_L or h_C , depending on the location under consideration.

9.5.2 Where a cut-out is made in the subdivision structure for the fitting of an access door, the strength and integrity of the subdivision structure are to be maintained.

9.6 Scantlings of subdivision doors

9.6.1 The plate thickness of subdivision doors of single plate construction is not to be less than the greater of:

$$t = 0,004s f(h k)^{0,5} \text{ mm, or}$$

$$t = 5,0 \text{ mm}$$

where

s, k = as defined in Pt 4, Ch 2, 1.5 Symbols 1.5.1

f = as defined in Table 1.9.1 *Watertight and deep tank bulkhead scantlings* in Pt 4, Ch 1 General Cargo Ships

h = h_T, h_L or h_C as defined in Pt 4, Ch 2, 9.2 Design loads 9.2.3, as appropriate.

9.6.2 For subdivision doors of a double plate construction the plate thickness is to be specially considered.

9.6.3 The scantlings of primary and secondary stiffeners of subdivision doors are to be based on direct strength calculations.

9.6.4 The direct strength calculations are also to provide an assessment of the door, under the design load, to enable the leakage and hence the drainage requirements of Pt 4, Ch 2, 9.9 *Watertightness and drainage* to be assessed.

9.6.5 For the purpose of the direct strength calculations. the stresses induced in the subdivision door, determined using the design loads from Pt 4, Ch 2, 9.2 Design loads, are not to exceed the permissible values given in Table 2.9.1 *Permissible stress values*. Checks are also to be carried out to ensure that the door will not buckle under the design loads.

Table 2.9.1 Permissible stress values

Stress type	Permissible stress
Direct stress	σ_0
Shear stress	$\frac{\sigma_0}{3}$
Combined stress	σ_0

Symbols
σ_0 = specified minimum yield stress, in N/mm ² (kgf/mm ²)

9.6.6 Where a cut-out is made within the subdivision door for the fitting of an access door, the strength of the subdivision door is to be maintained.

9.7 Closing, securing and supporting of subdivision doors

9.7.1 The closing and securing devices of doors are to comply with the following requirements:

- (a) Securing devices are to be simple to operate and easily accessible. They are to be of a design approved by LR for the intended purpose.
- (b) Securing devices and supporting devices are to be designed to withstand the design loads calculated in *Pt 4, Ch 2, 9.2 Design loads 9.2.1* in association with the permissible stresses shown in *Table 2.9.2 Permissible stress values*.
- (c) The arrangement of securing and supporting devices is to be such that threaded bolts do not carry support forces. The maximum tensile stress in way of threads of bolts not carrying support forces is not to exceed $0,5\sigma_0$.
- (d) For steel to steel bearings in securing and supporting devices, the bearing pressure is not to exceed $0,8\sigma_0$. For other bearing materials, the permissible bearing pressure is to be determined according to the manufacturer’s specification. The bearing pressure is to be calculated by dividing the design force by the projected bearing area.
- (e) Only the active supporting and securing devices having an effective stiffness in the relevant direction are to be included when calculating the reaction forces acting on the devices.
- (f) Securing devices are to be equipped with positive locking arrangements. Arrangements are to be such that the securing devices are retained in the closed position within design limits of inclination, vibration and other motion-induced loads and in the event of loss of any actuating power supply.
- (g) Hydraulic systems are to comply with *Pt 5, Ch 14, 9 Hydraulic systems*.
- (h) Control and monitoring arrangements are to comply with *Pt 6, Ch 2, 19 Ship safety systems*.

Table 2.9.2 Permissible stress values

Stress type	Permissible stress
Direct stress	$0,8\sigma_0$
Shear stress	$0,5\sigma_0$
Combined stress	$0,8\sigma_0$
Symbols	
σ_0 = specified minimum yield stress, in N/mm ² (kgf/mm ²)	

9.7.2 The reaction forces to be applied to the effective securing and supporting devices are to be determined using the applicable design loads calculated using the heads in *Pt 4, Ch 2, 9.2 Design loads* together with the weight of the door.

9.8 Access doors

- 9.8.1 Access doors are permitted to be fitted in subdivision doors or bulkheads in order to provide access between compartments.
- 9.8.2 Access doors may be manually operated.
- 9.8.3 The strength of access doors is to be not less than that of the surrounding structure.
- 9.8.4 Means are to be provided to ensure that access doors are closed and secured when not in use after the ship has left the berth.
- 9.8.5 A notice is to be displayed on the access doors stating that the door is to be closed and secured at all times when not in use, when the ship is under way.
- 9.8.6 Means are to be provided on the navigation bridge to indicate whether the access doors are opened or closed.

9.9 Watertightness and drainage

9.9.1 Subdivision doors and access doors are to be fitted with gaskets in order to minimise leakage. For access doors where down flooding could result, particular attention is to be paid to drainage requirements.

9.9.2 The gasket arrangement shall provide sufficient flexibility to absorb possible racking deformation.

9.9.3 Attention is drawn to the drainage requirements of *Pt 5, Ch 13, 3.1 General* with respect to the compartments created by subdivision structures.

9.9.4 The drainage arrangement for each compartment is to have sufficient capacity to handle leakage from any adjacent flooded compartment.

9.10 Ventilation of vehicle deck spaces

9.10.1 Attention is drawn to the ventilation requirement of *Pt 6, Ch 2, 14.13 Special requirements for ships with spaces for carrying vehicles with fuel in their tanks, for their own propulsion 14.13.4*, since subdivision structure could disrupt air flow.

9.11 Operating and Maintenance Manual

9.11.1 An Operating and Maintenance Manual for the subdivision doors is to be provided on board and is to contain the following:

- main particulars and design drawings,
- service conditions (e.g. service area restrictions),
- maintenance and function testing,
- register of inspections, repairs and renewals.

9.11.2 The Manual is to be submitted for approval. It is to contain a note recommending that recorded inspections of supporting and securing devices are to be carried out by the ship's staff at monthly intervals, or following incidents that could result in damage, including heavy weather or contact in the region of the subdivision doors. Any damages recorded during such inspections are to be reported to LR.

9.11.3 Documented operating procedures for closing and securing the subdivision doors are to be kept on board and posted in an appropriate place.

■ Section 10
Masts and standing rigging**10.1 General**

10.1.1 Masts are generally to be of tubular construction and may be either stayed or unstayed. Special consideration will be given to other forms of construction.

10.1.2 Masts are to be of sufficient strength to withstand the worst combination of loads from both the operational case with full sail, reduced sail configurations where applicable and survival conditions.

10.1.3 Masts are to be adequately supported using stays if necessary.

10.1.4 Drainage is to be provided to prevent the build-up of sea-water or condensation within the mast structure. Steel masts should, where possible, be coated internally with a suitable anti-corrosive preparation.

10.1.5 Openings in the masts for entry and exit of running rigging or cables should be adequately compensated with suitable insert plates or doublers.

10.1.6 Masts are to be efficiently integrated into the hull and in principle, carried through to the keel. Alternative arrangements of supporting masts will require to be specially considered.

10.1.7 Where ship response data are not available the values for roll, pitch and heave given in *Table 2.10.1 Ship motions* should be used.

10.2 Design loadings and allowable stresses

10.2.1 The mast and standing rigging design is to be considered with respect to the loads from the following conditions:

- R1 - Operational case with full press of sails for the maximum operational apparent wind speed as specified by the designer.
- R2 - Storm conditions with reduced sail.
- R3 - Survival case with sails reefed/stowed/weathervaning with the environmental loads resulting from the combination of a maximum wind speed of 63 m/sec and the accelerations produced by ship motions.

Table 2.10.1 Ship motions

Motion	Maximum single amplitude	Period, in seconds
Roll	$\Phi = \sin^{-1}\theta$ degrees but need not exceed 30° and is not to be taken less than 22°	$T_r = \frac{0,7B}{\sqrt{GM}}$
Pitch	$\Psi = 12e^{-0,0033L_{pp}}$ degrees, but need not exceed 8°	$T_p = 0,5\sqrt{L_{pp}}$
Heave	$\frac{L_{pp}}{80}$ m	$T_h = 0,5\sqrt{L_{pp}}$
<p>where L_{pp}, B as defined in Pt 3, Ch 1, 6 Definitions</p> <p>GM = transverse metacentric height of loaded ship, in metres</p> $\theta = \left(0,45 + 0,1\frac{L}{B}\right)\left(0,54 - \frac{L}{1270}\right)$		

10.2.2 The mast section is to be designed to have a margin against failure due to column buckling using the greatest combined design axial and bending stress in both the transverse and fore and aft directions.

10.2.3 For loadcases R1 and R2 described in Pt 4, Ch 2, 10.2 Design loadings and allowable stresses 10.2.1, the following condition is to be satisfied:

$$\frac{\sigma_b}{\sigma_y} + \frac{\sigma_a}{\sigma_c} \leq 0,67$$

For loadcase R3 the following condition is to be satisfied:

$$\frac{\sigma_b}{\sigma_y} + \frac{\sigma_a}{\sigma_c} \leq 0,85$$

where

- σ_b = is the bending stress in the mast section under consideration
- σ_y = is the tensile yield stress for the material
- σ_a = is the axial stress in the mast section under consideration
- σ_c = is the critical buckling stress for the mast section.

10.2.4 For thin walled masts, constructed from either flat or curved shells, calculations are to be submitted demonstrating adequate margin against local elastic instability.

10.3 Materials of mast construction

10.3.1 In general masts are to be constructed from either steel or aluminium alloy tubular members, extrusions and/or welded constructions, and are, generally, to comply with LR's *Rules for the Manufacture, Testing and Certification of Materials, July 2015*, where appropriate.

10.3.2 Other materials will be specially considered.

10.4 Standing rigging

10.4.1 Standing rigging is to be so arranged such that it does not foul running rigging or interfere with the operation of the sails. Protection is to be provided against routine quay contacts.

10.4.2 Standing rigging is to be effectively attached to the masts, deck and hull structure and is to be so designed that it cannot become disconnected during operation.

10.4.3 Standing rigging is to be properly erected using tensioning devices to ensure that the correct pre-tension is applied as specified by the designer.

10.4.4 The initial pre-tension applied to standing rigging is to be measured and recorded.

10.5 Design loadings

10.5.1 The forces in the standing rigging are to be obtained by direct calculation methods for the load conditions given in *Pt 4, Ch 2, 10.2 Design loadings and allowable stresses 10.2.1*.

10.5.2 The minimum factors of safety on the breaking strength of shrouds and stays are as follows:

Sail cases R1 and R2	3,5
Survival case R3	2,0

10.6 Shroud and stay attachment points

10.6.1 Standing rigging is to be effectively attached to the masts, ship's deck or bulwark structure. Chain plates, mast eyeplates and the structure in way are to be reinforced to withstand a load of 1,2 x breaking strength of the appropriate shroud or stay.

Generally the hull structure in way of shroud/stay attachment should be capable of withstanding the wire breaking load without permanent deformation of the structure.

10.6.2 Increased mast wall thickness, or internal or external mast stiffening rings or diaphragms are to be arranged in way of the toes of shroud and stay eyeplates to resist mast wall punching shear loads. Where additional mast stiffening rings or diaphragms are not fitted, the mast wall is not to be less than:

$$t_{\text{wall}} = \frac{2(h_{\text{eye}} B_s k_{\text{mast}})}{(t_{\text{eye}} l_{\text{eye}})} \text{ (mm)}$$

where

h_{eye} = eyeplate pin axis from mast wall, mm, see *Figure 2.10.1 Definition of h_{eye} and l_{eye}*

B_s = breaking strength, in kN, of attached rigging component

k_{mast} = mast material factor, k

t_{eye} = eyeplate thickness, mm, see *Figure 2.10.1 Definition of h_{eye} and l_{eye}*

l_{eye} = eyeplate length, mm, see *Figure 2.10.1 Definition of h_{eye} and l_{eye}*

10.6.3 The attachments of the stays and shrouds are to be efficiently integrated into the hull structure and due regard given to any attachments to the sheerstrake.

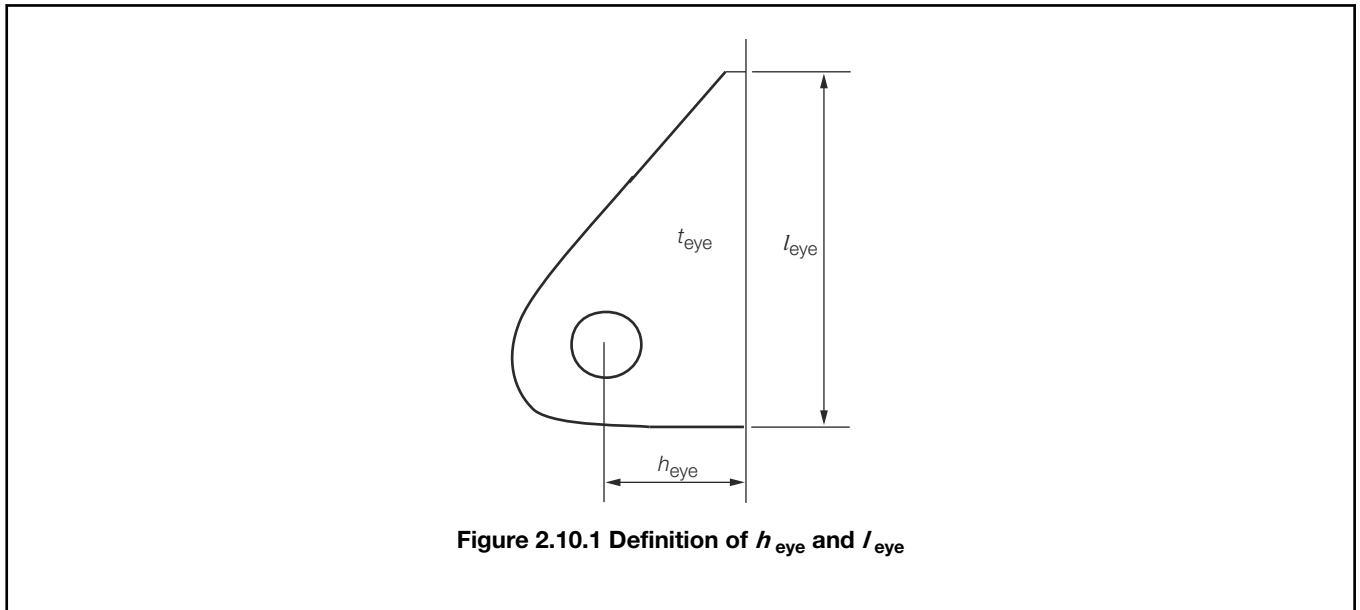

10.6.4 Where it is intended to use mechanical attachments (bolting) of running rigging or other gear to the mast walls, the number of holes are to be kept to a minimum and are to be staggered in order to maintain the structural integrity of the mast. All details are to be submitted.

10.7 Materials for rigging

10.7.1 In general, standing rigging is to be made from galvanised steel wire rope (GSWR) with galvanised steel rigging screws, shackles and terminations, and is to comply with the requirements of LR. Special consideration will, however, be given to other rigging materials.

10.7.2 Alternatively, stainless steel wire rope or solid rod rigging may be used in place of GSWR.

10.7.3 The steel wire rope, solid rods and loose fittings used for standing rigging are to be manufactured to a recognised National or International Standard and at an LR approved works.

10.7.4 Rigging components from other sources will be specially considered.

10.7.5 Where stainless steel rigging is employed, particular attention is to be given to the selection of the grade of material used as some stainless steels are prone to stress corrosion cracking and consequent fatigue failure, the onset of which is not readily observed.

10.7.6 Attention is drawn to the requirements of the Flag Administration for the vessel who may have requirements regarding the application of certain materials, systems or criteria.

10.8 Testing and certification

10.8.1 All equipment items used for standing rigging, including loose items of gear such as shackles, bottle screws, sheaves, etc. are to be tested and surveyed in accordance with LR requirements. For systems employing specialised devices or materials, individual consideration will be given to the testing and survey requirements.

10.8.2 For sailing passenger ships, the equipment requirement will be in accordance with the letter and numeral two grades higher than that corresponding to the calculated Equipment Numeral.

■ Section 11 Miscellaneous openings

11.1 General

11.1.1 The requirements of *Pt 3, Ch 11, 6 Miscellaneous openings* are to be complied with.

11.2 Openings in main vehicle deck

11.2.1 Where the main vehicle deck is enclosed, all companionways and openings in the deck which lead to spaces below are generally to be protected by steel doors or hatch covers. Approved fire doors may be accepted in lieu of steel doors. The sills or coamings are to be not less than 230 mm above the main vehicle deck, with the exception of those leading to machinery spaces which are to have sills or coamings not less than 380 mm. Exceptionally, when such openings are to be kept closed at sea, sills or coamings may be reduced in height, provided that the sealing arrangements are adequate. In such cases, the doors or hatch covers are to be secured weathertight by gaskets and a sufficient number of clamping devices. Such items as portable plates in the main vehicle deck arranged for the removal of machinery parts, etc. may be arranged flush with the deck, provided they are secured by gaskets and closely spaced bolts at a pitch not exceeding five diameters.

11.2.2 Scuppers from vehicle or cargo spaces above the bulkhead deck fitted with an approved fixed pressure water spray fire-extinguishing system are to be led directly overboard and are to be fitted with means of preventing water from passing inboard in accordance with *Pt 3, Ch 12, 4.2 Closing appliances*.

11.2.3 Inboard draining scuppers do not require valves but are to be led to suitable drain tanks (not engine room or hold bilges) and the capacity of the tanks is to be sufficient to hold approximately 20 minutes of drenching water. The arrangements for emptying these tanks are to be approved and suitable high level alarms provided.

11.2.4 A drainage system is to be arranged in the area between bow door and ramp, or where no ramp is fitted, between the bow door and inner door. The system is to be equipped with an audible and visual alarm function to the navigation bridge being set off when the water levels in these areas exceed 0,5 m or the high water level alarm, whichever is the lesser.

11.2.5 The drainage arrangement for each area is to have sufficient capacity to prevent accumulation of water in case of leakage. Scuppers are to be provided on both sides of the ship with a diameter not less than 50 mm and in accordance with *Pt 3, Ch 12, 4 Scuppers and sanitary discharges*. Alternatively, a bilge suction should be provided.

11.2.6 If the main vehicle deck is not totally enclosed, scuppers or freeing ports are to be provided consistent with the requirements of *Pt 3, Ch 8, 5.3 Freeing arrangements*.

11.2.7 Air pipes from cofferdams or void spaces may terminate in the enclosed 'tween deck space on the main vehicle deck provided the space is adequately ventilated and the air pipes are provided with weathertight closing appliances.

11.2.8 Between the bow door and the inner door a television surveillance system is to be fitted with a monitor on the navigation bridge and in the engine control room. The system must monitor the position of doors and a sufficient number of their securing devices. Special consideration is to be given for lighting and contrasting colour of objects under surveillance, *see also Pt 4, Ch 2, 8.5 Arrangements for the closing, securing and supporting of doors 8.5.7*.

11.3 Strength assessment of windows in large passenger ships

11.3.1 On windows in the second tier and higher above the freeboard deck, a glazing equivalent may be fitted in lieu of deadlights/storm covers. The thicknesses and arrangements are to be acceptable to the National Authority with whom the ship is registered and/or by the Administration within whose territorial jurisdiction the ship is intended to operate. For arrangements of glazing acceptable to LR, *see Table 2.11.1 Acceptable arrangements of glazing in lieu of portable storm covers/deadlights*. Alternative arrangement of glazing in lieu of deadlights/storm covers may be accepted provided details are submitted for consideration.

11.3.2 For passenger ships the design pressure, H_d , on windows is to be taken as given in *Table 2.11.2 Design pressure, H_d , on windows*, or an equivalent National or Internationally Recognised Standard.

11.3.3 The thickness, t_o , of toughened safety glass is to be taken as given in *Table 2.11.3 Thickness of toughened glass*.

11.3.4 Toughened safety glass of laminated construction will also be accepted, provided the requirements of *Pt 3, Ch 11, 6.5 Side scuttles, windows and skylights 6.5.24* are complied with.

Table 2.11.1 Acceptable arrangements of glazing in lieu of portable storm covers/deadlights

In lieu of portable storm covers	In lieu of deadlights and storm covers	
<p style="text-align: center;"> $t_1^2 + (0,77t_2)^2 + t_1^2 = (1,2t_0)^2$ </p>	<p style="text-align: center;"> $t_0^2 + t_0^2 = (1,4t_0)^2$ </p>	<p style="text-align: center;">35 mm gap</p>
Symbols		
t_0 = minimum thickness of toughened glass as calculated in Table 2.11.3 Thickness of toughened glass		

Table 2.11.2 Design pressure, H_d , on windows

Window location	Design pressure head H_d in metres
Between the design waterline and a point $Z_{1,5}$ m above the waterline	Per BS MA 25: 1973
Between a point $Z_{1,5}$ m above the waterline and the deck immediately above (at $Z_{d1,5}$)	1,5
Over the next 2 'tween deck heights	$1,5 - f_w \left(\frac{Z_w - Z_{d1,5}}{H_{t1} + H_{t2}} \right)$
For subsequent decks to the top of the navigation bridge	0,25 sides and aft ends 0,75 house fronts
From the top of the navigation bridge to the uppermost deck, for house fronts	0,75 at top of navigation bridge 0 at uppermost continuous deck, with linear variation between, but not less than 0,25
From the top of the navigation bridge to the uppermost deck, at sides and aft ends	0,25

Symbols	
f_w	= 1,25 in way of sides and ends of superstructures = 0,75 in way of house fronts
$Z_{1,5}$	= the vertical location in metres above the waterline at which the BS MA:25 pressure as given in Annex E of BS MA:25 (1973) is 1,5 t/m ²
$Z_{d1,5}$	= the vertical location in metres of the deck at which the pressure is 1,5 t/m ² from <i>Table 2.11.1 Acceptable arrangements of glazing in lieu of portable storm covers/deadlights</i>
Z_w	= the vertical location in metres above the waterline to the point under consideration
$H_{t1} + H_{t2}$	= sum of the appropriate 'tween deck heights in metres

Table 2.11.3 Thickness of toughened glass

Window type	Thickness, t_o , in mm
Rectangular	$b\sqrt{\frac{H_d\beta}{4000}}$
Circular	$0,0175r\sqrt{H_d}$
Semi-circular	$0,011r\sqrt{H_d}$
Symbols	
b	= length of shorter side of window, in mm
H_d	= design pressure head, in metres, as calculated in <i>Table 2.11.2 Design pressure, H_d, on windows</i>
β	= $0,54A_R - 0,078A_R^2 - 0,17$ for $A_R \leq 3$ = 0,75 for $A_R > 3$
A_R	= aspect ratio of window, in mm = a/b
a	= length of longer side of window, in mm
r	= the radius of the window, in mm

11.4 Frame design and testing

11.4.1 **Application.** The testing requirements contained in this Section are for all exterior window and glass balustrade designs on all tiers for passenger ships regardless of length. The testing is to be carried out for characteristic window and balustrade sizes (largest, smallest) and forms (circular, semicircular and rectangular) for each passenger ship. Window and balustrade designs, which are not covered by Type Approval Certification, will require prototype testing in order to confirm structural integrity and weather or water tightness as required. Tests are to be carried out to the satisfaction of the Surveyor.

11.4.2 **Water tightness.** hydrostatic test is to be carried out in order to examine the water tightness of windows. This is carried out by applying the design pressure head H_d , as calculated in *Pt 4, Ch 2, 11.3 Strength assessment of windows in large passenger ships*, to the external face of the window and maintained at this level for at least 15 minutes.

11.4.3 **Structural testing.** A hydrostatic test is to be carried out in order to examine the capability of the frame, mullions and glass retaining arrangements. This is carried out by applying a test pressure of $4H_d$ (H_d as calculated in Pt 4, Ch 2, 11.3 *Strength assessment of windows in large passenger ships* for windows and Pt 4, Ch 2, 12.3 *Weather design loads* for balustrades) to the external face of the window. Alternatively this test may be carried out using a steel plate in place of the glass. Ideally, the steel plate should be of a suitable reduced thickness in order to simulate the flexural performance of the glass.

11.4.4 Equivalent proposals for testing will be considered. Where alternative testing procedures are proposed, these are to be agreed with LR before commencement.

11.4.5 **Chemically toughened glass.**

- (a) Chemically toughened glass may be used in lieu of thermally toughened glass provided it can be demonstrated the strength of the arrangement is at least equivalent in strength to that of thermally toughened glass.
- (b) The glazing system is to be of laminated construction.
- (c) Method of testing will be specially considered.

11.4.6 The overlap between glazing and the retaining frame is not to be less than 12 mm.

11.5 Strength of mullions

11.5.1 The section modulus of mullions is not to be less than:

$$Z = 10,78H_d l A_m k 10^{-9} \text{cm}^3$$

where

a = see Table 2.11.4 *Mullion arrangements*

b = see Table 2.11.4 *Mullion arrangements*

r = see Table 2.11.4 *Mullion arrangements*

l = a for rectangular windows

= $2r$ for semi-circular windows

H_d = design pressure head, in metres, as calculated in Pt 4, Ch 2, 11.3 *Strength assessment of windows in large passenger ships* 11.3.2

A_m = ab for rectangular windows

= $1,22r^2$ for semi-circular windows

k = as defined in Pt 4, Ch 2, 1.5 *Symbols* 1.5.1.

Table 2.11.4 Mullion arrangements

Rectangular windows	Semi-circular windows
Symbols	
<p>a = dimension parallel to mullion, in mm</p> <p>b = length of shorter side of window, in mm</p> <p>r = radius of the window, in mm</p>	

11.6 Bonded windows and side scuttles

11.6.1 A 'bonded window' or 'bonded side scuttle' is one in which the glazing material is secured in its frame from outside of the ship by glue or other adhesive material. No mechanical fixing is provided for the glazing. Bonded windows and side scuttles are to comply with the requirements of *Pt 4, Ch 2, 11 Miscellaneous openings*. Proposals to secure glazing from the inside of the ship are to be specially considered using the requirements in this Section as a basis. It should be noted that bonding from the inside is not recommended and where it is proposed, further testing will be required. Non-load bearing secondary bonded glazing, e.g. glazing to improve thermal insulation, is not required to comply with the requirements of this sub- Section.

11.6.2 The adhesive is to be flexible enough to support the glazing without holding it firm. The glue strip is to be elastic, with width and thickness designed to allow the glazing to move in both directions in the plane of the glazing without undue forces on the bonding or the substrate. The glass is to be free to settle under-load and not to be forced to follow deflections in the supporting structure. If substantial racking of the glazing opening under-load is expected, the bonding is to be designed to accommodate such deflections.

11.6.3 Bonded windows and side scuttles may be considered as acceptable, in general, depending on their position, size of vessel and applicable statutory requirements, noting the distinction between glazing and the frame, which may have different requirements.

11.6.4 Bonded windows are not permitted in galley areas, including glazing in galley doors (internal or external). They are not permitted on escape routes and evacuation routes where a fire rating is required. The fire integrity of bulkheads is not to be impaired.

11.6.5 Bonded windows and side scuttles are not acceptable on fire-fighting vessels, i.e. those with a fire-fighting notation.

11.6.6 The failure of laminated glass is considered to pose a lower risk to safety than that of single pane glass. In the event of breaking, laminated glass more readily holds together and tends not to break up into large sharp pieces. Therefore, in general, laminated glazing is preferred. When laminated glass is used, the sealant is to be compatible with the interlayer. Lamination thickness is to be in accordance with *Pt 3, Ch 11, 6.5 Side scuttles, windows and skylights 6.5.24*. Special consideration will be given to single pane toughened safety glass.

11.6.7 The durability of the adhesive and the sealant in the long term marine environment is to be considered in the approval process. Adhesive is to be approved in accordance with *Ch 14, 2.15 Adhesive and sealant materials* of the Rules for Materials. The adhesive bead is to be resistant to or protected from UV radiation, either by an optically dense area at the edges of the glazing or by overlapping trim or UV shielding tape. The adhesive bead is to be resistant to or protected from fungal attack. Arrangements are to be in accordance with the adhesive manufacturer’s published guidelines and relevant LR Rules.

11.6.8 The edges of the bonding recess are to be rounded to facilitate the application of the sealant without air entrapment. The width of the gap between the flange and the glazing is to be large enough to accommodate the movement of the glazing as a result of hull deflection and thermal expansion, see *Figure 2.11.1 Gap width between flange and window, bonded from outside of the ship*. Recommended gap widths for bonded windows are to be taken as:

Gap width	Length of longest side of window
10–15 mm	<1,5 m
15–20 mm	1,5–3,0 m.

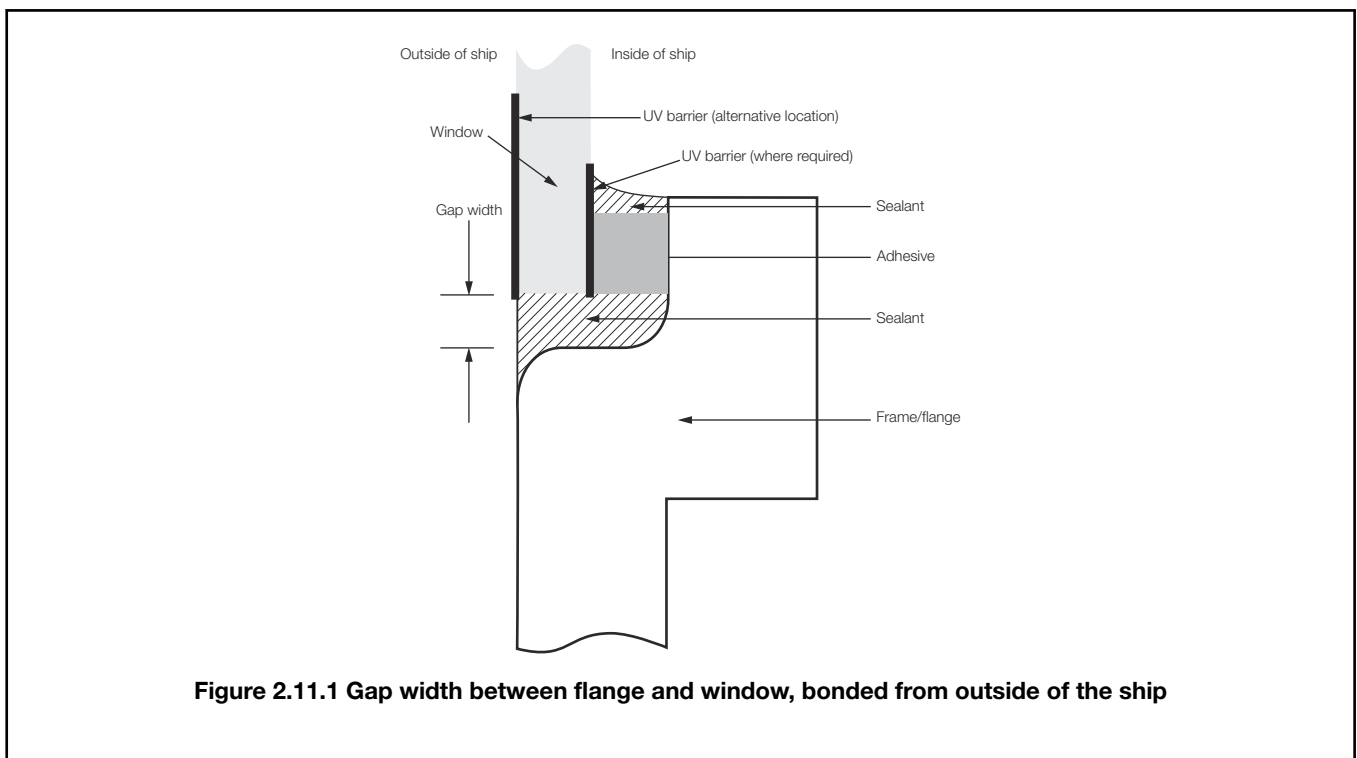

11.6.9 The minimum adhesive width and thickness are to be in accordance with the adhesive manufacturer’s published guidelines.

■ **Section 12**
External glass balustrades

12.1 General

12.1.1 Attention is drawn to relevant requirements of National and International Standards concerning the construction of barriers using glass, as well as applicable statutory regulations for the Protection of Crew, see the *Load Lines, 1966/1988 - International Convention on Load Lines, 1966, as Amended by the Protocol of 1988* and its Protocol of 1988.

12.1.2 The requirements of this Section apply solely to external glass balustrades. External glass balustrades are barriers constructed with glass that are used on exposed decks.

12.2 Design considerations

12.2.1 External glass balustrades should not be situated in areas deemed essential for the operation of the ship. Such areas include mooring decks, lifeboat decks, external muster stations and in the vicinity of davits. Where external glass balustrades are not to be used, more traditional bulwarks or guard rails are to be fitted in accordance with *Pt 3, Ch 8, 5 Bulwarks, guard rails and other means for the protection of crew*.

12.2.2 External glass balustrades are to be designed to resist the most unfavourable anticipated loads within service, including weather loads or personnel loads without unacceptable deflection. Detailed plans and calculations are to be submitted clearly indicating the position, arrangement and the anticipated loads for all external glass balustrades.

12.2.3 External glass balustrades are to be not less than 1,0 m in height.

12.2.4 External glass balustrades are to provide water freeing areas in accordance with *Pt 3, Ch 8, 5.3 Freeing arrangements*.

12.2.5 Laminated toughened safety glass is to be used for the glazing of all external glass balustrades.

12.2.6 In general openings should not be greater than 76 mm unless required for water freeing. Openings for water freeing are not to be greater than 230 mm.

12.2.7 Consideration should be given to minimising the possibility of surface deterioration of the balustrade glass infill panels in service by means of suitable edge protection or finishes.

12.2.8 The total horizontal deflection of external glass balustrades is not to exceed 25 mm when subject to the anticipated loads specified in *Pt 4, Ch 2, 12.3 Weather design loads* or *Pt 4, Ch 2, 12.4 Personnel design loads*.

12.2.9 Special consideration may be given to external glass balustrades that are not constructed in accordance with this Section.

12.3 Weather design loads

12.3.1 External glass balustrades are to be designed to resist the anticipated weather loadings dependent on their location specified in *Table 2.11.2 Design pressure, H_{dt} on windows*. It is recommended that the equivalent monolithic thickness of the glass infill panels be derived through direct calculations using the design pressures given in *Table 2.11.2 Design pressure, H_{dt} on windows* and a safety factor of 2 on the characteristic failure strength of toughened safety glass. The equivalent laminated toughened safety glass thickness can then be obtained in accordance with *Pt 3, Ch 11, 6.5 Side scuttles, windows and skylights 6.5.24*.

12.4 Personnel design loads

12.4.1 External glass balustrades are to be designed to resist the most unfavourable anticipated personnel loads, which are to be specified by the designer. The specified personnel loads are to be not less than 1,5 times the commensurate loads specified in *EN 1991-1-1:2002 Eurocode 1: Actions on structures – Part 1-1: General actions – Densities, self-weight, imposed loads for buildings*.

12.5 Balustrade stanchions

12.5.1 External glass balustrades are to be fitted with fixed stanchions of adequate strength to resist the anticipated loads imposed between stanchions specified in *Pt 4, Ch 2, 12.3 Weather design loads* and *Pt 4, Ch 2, 12.4 Personnel design loads* using a bending stress coefficient not greater than 0,6.

12.6 Balustrade top rail

12.6.1 External glass balustrades are to be fitted with a continuous top rail.

12.6.2 The top rail is to be sufficiently stiff so as not to permanently deflect when subject to the personnel loads specified in *Pt 4, Ch 2, 12.4 Personnel design loads*.

12.6.3 The top rail is to be sufficiently stiff so as not to deflect more than $L_b/96$ when subject to the personnel loads specified in *Pt 4, Ch 2, 12.4 Personnel design loads*.

where

$$L_b = \text{span of top rail between stanchions, in m.}$$

12.6.4 The top rail minimum section modulus is to be greater than:

$$Z = \frac{141 \times q_k \times L_b^2}{f_\sigma \sigma_o} \text{cm}^3$$

where

L_b = span of top rail between stanchions, in m.

q_k = line load on top rail, in kN/m, in accordance with *Pt 4, Ch 2, 12.4 Personnel design loads* and to be taken not less than 1 kN/m

σ_o = specified minimum yield stress in N/mm².

f_σ = bending stress coefficient not to be taken greater than 0,6.

12.7 Impact Resistance and Containment

12.7.1 External glass balustrades are to be subject to a prototype pendulum impact test in accordance with *EN 13049:2003 Windows — Soft and heavy body impact — Test method, safety requirements and classification* or an equivalent National or International Standard utilising a drop height of not less than 1,5m. The test specimens including the retaining arrangements should be the same as the finished installation.

■ Section 13 Direct calculation

13.1 Application

13.1.1 Direct calculations are to be employed in derivation of scantlings where required by preceding Sections of this Chapter or by related provisions included in *Pt 3 Ship Structures (General)*.

13.1.2 Direct calculation methods are also generally to be used where additional calculations are required by the Rules in respect of unusual structural arrangements.

13.2 Procedures

13.2.1 For details of LR's direct calculation procedures, see *Pt 3, Ch 1, 2 Direct calculations*. For requirements concerning use of other calculation procedures, see *Pt 3, Ch 1, 3 Equivalents*.

Section

- 1 **General**
- 2 **Longitudinal strength**
- 3 **Floors in single bottoms**
- 4 **Panting and strengthening of bottom forward**
- 5 **Machinery casings**
- 6 **Freeing arrangements**
- 7 **Towing arrangements**
- 8 **Fenders**
- 9 **Escort operation, performance numeral and trials**

■ Section 1 General

1.1 Application

1.1.1 Sections 1 to 8 of this Chapter apply to tugs.

1.1.2 *Pt 4, Ch 3, 9 Escort operation, performance numeral and trials* of this Chapter applies to tugs and offshore supply ships intended to provide escort operation.

1.1.3 The scantlings and arrangements are to be as required by *Pt 4, Ch 1 General Cargo Ships* except as otherwise specified. The draught, *T*, used for the determination of scantlings is to be not less than 0,85*D*.

1.2 Class notations

1.2.1 Ships complying with relevant requirements will be assigned one or more of the class notations given in *Table 3.1.1 Class notations*.

1.2.2 Tugs intended to be operated only in suitable areas or conditions which have been agreed by the Committee, as defined in *Pt 1, Ch 2, 2.3 Class notations (hull) 2.3.6 to Pt 1, Ch 2, 2.3 Class notations (hull) 2.3.10*, will receive individual consideration on the basis of the Rules with respect to the environmental conditions agreed for the design basis and approval. In particular, tugs complying with the requirements of this Chapter and *Pt 3, Ch 13, 7 Equipment* for the relevant reduced equipment requirements, will be eligible to be classed:

- **A1 tug protected waters service**; or
- **A1 escort tug protected waters service**; or
- **A1 escort tug EPN (F,B,V,C) protected waters service**; see *Pt 1, Ch 2, 2.3 Class notations (hull) 2.3.6*; or
- **100A1 tug with service restriction notation**; or
- **100A1 escort tug with service restriction notation**; or
- **100A1 escort tug EPN (F,B,V,C) with service restriction notation**;

whichever is applicable.

1.2.3 The Regulations for classification and the assignment of class notations are given in *Pt 1, Ch 2 Classification Regulations* to which reference should be made.

Table 3.1.1 Class notations

Class Notation	Applicable Sections
100A1 tug	<i>Pt 4, Ch 3, 1 General to Pt 4, Ch 3, 8 Fenders</i>
100A1 escort tug	<i>Pt 4, Ch 3, 1 General to Pt 4, Ch 3, 9 Escort operation, performance numeral and trials, except Pt 4, Ch 3, 9.3 Performance numeral and trials</i>
100A1 escort tug EPN (F, B, V, C)	<i>Pt 4, Ch 3, 1 General to Pt 4, Ch 3, 9 Escort operation, performance numeral and trials</i>
<p>Note Tugs which comply with the anchor handler requirements in <i>Pt 4, Ch 4, 1 General to Pt 4, Ch 4, 4 Hull envelope framing</i> and <i>Pt 4, Ch 4, 10 Anchor handler</i> will be eligible for the additional notation anchor handler.</p>	

1.3 Information required

1.3.1 In addition to the information and plans required by *Pt 3, Ch 1, 5 Information required*, plans covering the following items are to be submitted for approval where applicable:

- Support structure and foundations of towing equipment.
- Skegs, propeller guards and other structures which support the weight of the vessel during dry-docking.

1.3.2 The following supporting documents are to be submitted for information:

- Towing arrangements, including lines of action, magnitudes and corresponding points of application of towline pulls on towing equipment.
- Details of the breaking strength of the components of the towline system, together with maximum pull and brake holding load, or equivalent, of towing winches where applicable.

■ *Section 2*
Longitudinal strength

2.1 General

2.1.1 The longitudinal strength standard is to comply with the relevant requirements of *Pt 3, Ch 4 Longitudinal Strength*.

2.1.2 The requirements of *Pt 3, Ch 4, 8.3 Loading instrument* regarding loading instruments are not applicable to tugs.

■ *Section 3*
Floors in single bottoms

3.1 Floors

3.1.1 Single bottom floors are to be in accordance with the requirements of *Pt 4, Ch 1, 7 Single bottom structure*, except that floors clear of the machinery space may be flanged in lieu of a face plate being fitted.

■ *Section 4***Panting and strengthening of bottom forward****4.1 Panting region reinforcement**

4.1.1 The arrangements to resist panting required by *Pt 3, Ch 5 Fore End Structure* do not apply to tugs less than 46 m in length. In tugs 46 m or more in length, additional stiffening is also to be fitted in the 'tween decks throughout the panting region.

4.2 Strengthening of bottom forward

4.2.1 The requirements for strengthening of bottom forward detailed in *Pt 3, Ch 5 Fore End Structure* do not apply to tugs.

■ *Section 5***Machinery casings****5.1 Escape hatches**

5.1.1 Any emergency exit from the machinery room to the deck is to be capable of being used at extreme angles of heel, and should be positioned as high as possible above the waterline and on or near the ship's centreline. Covers to escape hatches are to have hinges arranged athwartships. Coaming heights are to be at least 600 mm above the upper surface of the deck.

■ *Section 6***Freeing arrangements****6.1 General**

6.1.1 If the only means of access to the wheelhouse is external, then stormboards, or an equivalent, are to be fitted between the deckhouse and the ship's sides forward of any deckhouse doors up to the height of the bulwark rail. A gap is to be left between the deck and the bottom board for freeing purposes.

■ *Section 7***Towing arrangements****7.1 Towing equipment**

7.1.1 For tugs which normally tow over the stern with the main towline connection to the hull ahead of the propellers, the position of towline connection is normally to be five to 10 per cent of the ship's length abaft amidships, but in no circumstances is it to be sited forward of a position, five per cent of the ship's Rule length abaft the longitudinal centre of gravity of the tug in any anticipated condition of loading.

7.1.2 The attachment of the towline to the tug is to be located as low as practicable in order to minimise heeling moments arising from working conditions. Reliable slip arrangements which facilitate towline release regardless of the angle of the towline are to be provided.

7.1.3 It is recommended that the slip arrangements should also be operable from the bridge. The arrangements should be tested to the Surveyor's satisfaction. The breaking strength of the hook, or its equivalent, should generally be 50 per cent in excess of that of the towline, see *Pt 3, Ch 13, 7 Equipment*.

7.2 Towing equipment foundations

7.2.1 Direct support for towing equipment by means of pillars and/or pillar bulkheads is to be arranged as far as this is practicable.

7.2.2 The design load for the support structure in way of towing equipment is to be not less than the breaking strength of the towline system. The design load is also to be taken as not less than the breaking strength of the tow hook or the brake holding load, or equivalent, of the winch, whichever is appropriate.

7.2.3 Scantlings of pillars and pillar bulkheads are to be in accordance with *Pt 4, Ch 1, 4.4 Deck supporting structure*.

7.2.4 Scantlings of deck girders and transverses forming the support structure of towing equipment are to be determined by direct calculations using the following stresses:

$$\tau = \left(\frac{87}{k} \text{ N/mm}^2 \right) \quad \left(\frac{8,9}{k} \text{ kgf/mm}^2 \right)$$

$$\sigma = \left(\frac{150}{k} \text{ N/mm}^2 \right) \quad \left(\frac{15,3}{k} \text{ kgf/mm}^2 \right)$$

$$\sigma_e = \left(\frac{213}{k} \text{ N/mm}^2 \right) \quad \left(\frac{21,7}{k} \text{ kgf/mm}^2 \right)$$

where

τ = shear stress, in N/mm²

σ = bending stress, in N/mm²

k = material factor, see *Pt 3, Ch 2, 1.2 Steel*

σ_e = equivalent stress, in N/mm²

$$= \sqrt{\sigma^2 + 3\tau^2}$$

7.2.5 Generally, the foundations of towing fairleads are to be carried through the deck and integrated into suitable underdeck structure.

7.2.6 On tugs which utilise an indirect method of towing, attention is drawn to the increased out-of-plane forces that occur in towing fairleads.

■ Section 8

Fenders

8.1 Ship's side fenders

8.1.1 An efficient fender is to be fitted to the ship's side at deck level extending all fore and aft.

■ Section 9

Escort operation, performance numeral and trials

9.1 General

9.1.1 An escort tug is a tug intended for escort operation. Escort operation is an operation in which the tug closely follows the assisted ship providing control by steering and braking, as necessary.

9.1.2 Escort tugs are to be capable of utilising methods of towing through which steering and braking forces are generated by a combination of propulsive and hydrodynamic forces developed by the tug, acting on the towline to the attended ship, see example in *Figure 3.9.1 Forces generated during a typical escort mode*.

9.1.3 The intact stability of the tug during escort operation is to comply with a Standard recognised by the National Administration with whom the ship is registered and/or by the National Administration within whose territorial jurisdiction the tug is intended to operate, as applicable. Attention is drawn to the inherent problems relating to the quick release of the towline and the sudden loss of propulsion power during the escort operation in addition to the maximum steering and braking forces.

9.2 Towing arrangements

9.2.1 The specified breaking strength of the towline is to be at least 2,5 x maximum design towline force.

9.2.2 The towing winch is to include a system of continuous load monitoring, with a bridge readout display and an overload prevention system, which is to be operational during escort duties. The overload prevention system is to be designed with the capability to pay out the towline in a controlled manner when the load reaches the maximum design towline force, and is to be capable of alerting the Master and crew.

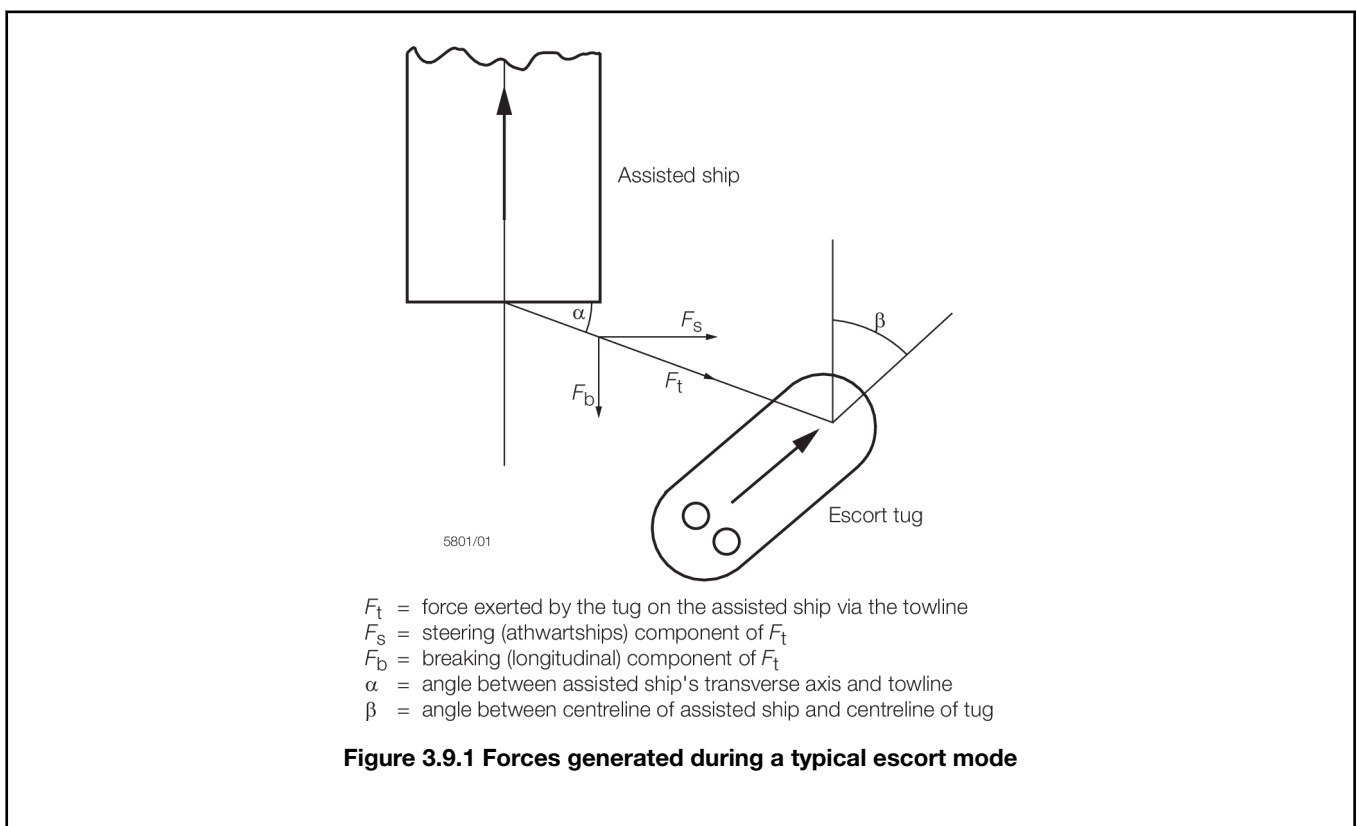

9.3 Performance numeral and trials

9.3.1 Escort tugs which carry out full scale performance trials in accordance with the requirements of this Section will be eligible to have the escort performance numeral **EPN (F,B,V,C)** appended to the **escort tug** notations, see Pt 4, Ch 3, 1.2 Class notations 1.2.1 and Pt 4, Ch 3, 1.2 Class notations 1.2.2 and Pt 4, Ch 4, 1.2 Class notations 1.2.2,

where

- F** is the maximum steering force (F_s), in tonnes, see Figure 3.9.1 Forces generated during a typical escort mode and Pt 4, Ch 3, 9.3 Performance numeral and trials 9.3.6.
- B** is the maximum braking force (F_b), in tonnes, see Figure 3.9.1 Forces generated during a typical escort mode and Pt 4, Ch 3, 9.3 Performance numeral and trials 9.3.6.
- V** is the speed, in knots, at which **F** and **B** are determined.
- C** is the time, in seconds (s), required for the escort tug in manoeuvring from maintained oblique position of tug giving maximum steering force F_s on one side of assisted vessel to mirror position on the other side, see Pt 4, Ch 3, 9.3 Performance numeral and trials 9.3.6. The towline angle, α , need not be taken less than 30°, see Figure 3.9.1 Forces generated during a typical escort mode.

9.3.2 The performance numeral may be determined with speed V equal to either 8 knots or 10 knots. If both sets of numerals are determined at the trials then the class notation will include them all.

9.3.3 A trials plan, which includes the estimated forces, is to be submitted and approved prior to trials being undertaken.

9.3.4 The trials of the escort tug are to be performed using a ship capable of maintaining almost constant heading and speed when subjected to the steering and braking forces from the escort tug.

9.3.5 The following trials are to be carried out in calm weather conditions and in the presence of a Lloyd's Register Surveyor:

- Steering and braking force capability test, see Pt 4, Ch 3, 9.3 Performance numeral and trials 9.3.6.
- Bollard pull test, see Pt 4, Ch 3, 9.3 Performance numeral and trials 9.3.8.

A record of the results is to be kept on board the escort tug.

9.3.6 Prior to commencing a trial, the following data are to be recorded:

- Wind speed and direction.
- Sea state.
- Current speed and direction.
- Water depth.
- The main particulars and the loading condition of the assisted ship.
- Loading condition of the escort tug.

9.3.7 **Steering and braking force capability test** is a test by which the steering force, F_s , and braking force, F_b , are determined when utilising the method, shown in *Figure 3.9.1 Forces generated during a typical escort mode*, of towing at a range of towline angles, α , from 0 to 90 degrees and for a range of operating speeds up to and including the maximum escort speed. The following parameters are to be continuously recorded during the test:

- Position, speed and heading of the assisted ship and the escort tug.
- Towline force, F_t .
- Angle of towline, α .
- Heel angle of the escort tug.
- Direction of thrust and power absorbed by all propellers and thrusters of the tug.
- Rudder angles of the tug.

9.3.8 The length of the towline is to represent a typical operating condition and is to be recorded prior to and at the completion of the test. The steering and braking forces for a given speed and angle can be calculated by using the average values of the recorded towline force.

9.3.9 **Bollard pull test** is to be carried out in accordance with LR's *Bollard Pull Certification Procedures Guidance Information*.

Section

- 1 **General**
- 2 **Longitudinal strength**
- 3 **Hull envelope plating**
- 4 **Hull envelope framing**
- 5 **Superstructures and deckhouses**
- 6 **Miscellaneous openings**
- 7 **Engine exhaust outlets**
- 8 **Transport and handling of limited amounts of hazardous and noxious liquid substances in bulk**
- 9 **Standby ship**
- 10 **Anchor handler**

■ Section 1 General

1.1 Application

1.1.1 This Chapter applies to sea-going ships specially designed and constructed for the carriage of specialised stores and cargoes to mobile offshore units and other offshore installations, and also to offshore tug/supply ships which in addition to the above perform the duties of a tug.

1.1.2 The scantlings and arrangements are to be as required by *Pt 4, Ch 1 General Cargo Ships*, except as otherwise specified in this Chapter.

1.1.3 Attention is drawn to the need for Masters to be able to assess the stability of their ships quickly and accurately in all service conditions, see *Pt 1, Ch 2, 3 Surveys - General*.

1.1.4 Where towing equipment is fitted, the requirements of *Pt 4, Ch 3, 7 Towing arrangements* are to be applied.

1.2 Class notations

1.2.1 In general, ships complying with the requirements of this Chapter and relevant additional requirements will be eligible for one or a combination of the notations indicated in *Table 4.1.1 Class notations applicable to Offshore Supply Ships*.

1.2.2 The following additional notations and annotations can be provided to give a further detailed description of features:

- **WDL(+)** (Weather deck load):

If the weather deck scantlings have been approved for a loading greater than a design head of 3,5 m, the notation **WDL(+)** may be added. If requested, the maximum permissible weather deck load and extent can be identified in the notation, e.g. **WDL(5,0 t/m2 from Aft to Fr. 26)**.

- **RD** (Relative density):

Where a ship has tanks appraised for a maximum permissible relative density greater than 1,025, the notation **RD(specified tank names, density)** may be added, see *Pt 4, Ch 1 General Cargo Ships*.

- **LFPL** (Low flashpoint liquids):

Ships intended for the carriage of liquids with flash point below 60°C (closed-cup test) in bulk are to be built and equipped in accordance with the relevant requirements of *Pt 4, Ch 4, 8 Transport and handling of limited amounts of hazardous and noxious liquid substances in bulk* and will be given the class notation **LFPL**. If requested, the concerned cargo, flash point (closed-cup test) and tank can be identified in the notation, e.g. **LFPL(methanol, 12°C, No. 7 centre tank)**.

1.2.3 The Regulations for classification and the assignment of class notations are given in *Pt 1, Ch 2 Classification Regulations*, to which reference should be made.

Table 4.1.1 Class notations applicable to Offshore Supply Ships

Class Notation	Requirements
100A1	<i>Pt 1, Ch 2 Classification Regulations</i>
Offshore supply ship	<i>Pt 4, Ch 4, 1 General to Pt 4, Ch 4, 7 Engine exhaust outlets</i>
Supply ship	<i>Pt 4, Ch 1 General Cargo Ships</i>
Standby ship	<i>Pt 4, Ch 4, 1 General to Pt 4, Ch 4, 7 Engine exhaust outlets and Pt 4, Ch 4, 9 Standby ship</i>
Anchor handler	<i>Pt 4, Ch 4, 1 General to Pt 4, Ch 4, 7 Engine exhaust outlets and Pt 4, Ch 4, 10 Anchor handler</i> <i>Pt 4, Ch 4, 5 Superstructures and deckhouses to Pt 4, Ch 4, 7 Engine exhaust outlets need not be applied if notation for Offshore supply ship is not applied</i>
Tug	<i>Pt 4, Ch 3, 1 General to Pt 4, Ch 3, 8 Fenders</i>
Escort tug	<i>Pt 4, Ch 3 Tugs, except Pt 4, Ch 3, 9.3 Performance numeral and trials</i>
Escort tug EPN (F,B,V,C)	<i>Pt 4, Ch 3 Tugs</i>
AHTS	<i>Pt 4, Ch 3, 1 General to Pt 4, Ch 3, 8 Fenders; and</i> <i>Pt 4, Ch 4, 1 General to Pt 4, Ch 4, 7 Engine exhaust outlets and Pt 4, Ch 4, 10 Anchor handler</i>
Oil Recovery	<i>Pt 7, Ch 5 Ships Equipped for Oil Recovery Operations</i>
<p>Note 1. A ship designed to fulfil more than one function can be assigned a combination of the notations listed above, e.g.:</p> <ul style="list-style-type: none"> • 100A1 Offshore supply ship/Standby ship • 100A1 Offshore supply ship/Anchor handler • 100A1 Offshore supply ship/Standby ship/Oil Recovery • Any combination of the requirements listed in this Table. <p>Note 2. The notation Offshore Supply Ship will be assigned to ships that are designed to be operated on unrestricted worldwide service.</p> <p>Note 3. The notation Supply Ship will be assigned to ships that are designed for operation in specified restricted locations where the environmental conditions are less severe than for unrestricted worldwide service.</p>	

1.3 Information required

1.3.1 In addition to the information and plans required by *Pt 3, Ch 1, 5 Information required*, plans covering the following items are to be submitted where applicable:

- Independent cargo tanks.
- Cargo tank foundations and securing arrangements.
- Towing arrangements, including supports and foundations of towing winches.
- Arrangements for the stowage of deck cargoes (cargo containment) and details of any associated racks or other similar structures and their supports/foundations together with information to indicate design loads.
- Movable decks, including the stowing arrangements for portable components.
- Freeing arrangements.

1.4 Symbols

1.4.1 The symbols are as defined in *Pt 4, Ch 1, 1.5 Symbols and definitions*.

■ *Section 2*
Longitudinal strength

2.1 General

2.1.1 The longitudinal strength standard is to comply with the relevant requirements of *Pt 3, Ch 4 Longitudinal Strength*.

2.1.2 The requirements of *Pt 3, Ch 4, 8.3 Loading instrument* regarding loading instruments are generally not applicable to offshore supply ships.

■ *Section 3*
Hull envelope plating

3.1 Side shell

3.1.1 The thickness of side shell is to be that required by *Pt 4, Ch 1, 5.4 Side shell* but is not to be less than given by *Table 4.3.1 Minimum side shell thickness*

3.1.2 As an alternative, where over the length of a vessel, portions of the sheerstrake that are not protected by an efficient fender, the sheerstrake is to be increased by a minimum of 5 mm thickness. The increased thickness shall extend from the deck level to not less than 600 mm below the deck level.

Table 4.3.1 Minimum side shell thickness

Ship type	Minimum thickness, mm
Offshore supply ships	9
Standby ships	8
Anchor handler	9

3.2 Weather decks

3.2.1 Where cargo is to be carried on weather decks, the scantlings are to be suitable for the specified loadings. The thickness, *t*, of deck plating is to be not less than the greater of:

(a)

$$t = 0,025L + 4.5 + t_a \text{ mm}$$

(b)

$$t = 0,1f_m s \sqrt{\frac{PF_D}{f_y \sigma}} + t_a \text{ mm}$$

Where

P = specified design load for weather deck, in tonnef/m²

$$= \frac{h}{1,39}$$

h = equivalent design head, in metres, not to be taken less than 3,5 m

s = spacing of secondary stiffeners, in mm

σ = yield stress of plating, in N/mm²

F_D = as defined in *Pt 3, Ch 4, 5.7 Local reduction factors*

f_m = 0,75

f_y = 0,67

t_a = 2,5 mm, in general

= 1,0 mm, for ships with dedicated class notation **Standby ship**.

3.2.2 Scantlings are to be increased locally where specialised cargoes are likely to induce concentrated loads that exceed the specified design load. Acceptable stress levels are given in *Pt 4, Ch 3, 7.2 Towing equipment foundations 7.2.4*.

3.3 Cargo containment

3.3.1 Means are to be provided to enable deck cargoes to be adequately secured and protected. In general, suitable inner bulwarks, rails, bins or storage racks of substantial construction are to be provided and properly secured to adequately strengthened parts of the hull structure. Properly designed locking equipment or efficient means of lashing containers are to be fitted where appropriate. Small hatches (including escape hatches), valve controls, ventilators, air pipes, etc. are to be situated clear of the cargo containment areas.

Section 4 Hull envelope framing

4.1 General

4.1.1 The section moduli of side longitudinals, the main and 'tween deck frames are to be not less than kZ , cm³ where

k = 1,25 in general

= 1,10 for ships with dedicated class notation **Standby ship**

Z = as required by *Pt 4, Ch 1, 6 Shell envelope framing, Pt 3, Ch 5, 4 Shell envelope framing and Pt 3, Ch 6, 4 Shell envelope framing* for the appropriate location.

4.1.2 Frames are not to be scalloped.

4.1.3 The scantlings of deck secondary stiffeners are to be in accordance with the requirements of *Table 1.4.4 Cargo and accommodation deck longitudinals(1)* or *Table 1.4.5 Strength/weather, cargo and accommodation deck beams(2)* in *Pt 4, Ch 1 General Cargo Ships*, where h_2 is to be taken as the specified design loading and not less than a design head of 3,5 m.

Section 5 Superstructures and deckhouses

5.1 Scantlings

5.1.1 The scantlings of deckhouses situated on the forecastle deck and above are to comply with the requirements of *Table 4.5.1 Superstructures and deckhouses on forecastle deck*.

5.1.2 The scantlings of forecastle end bulkheads are to be not less than those required by *Table 4.5.1 Superstructures and deckhouses on forecastle deck* for aft ends of deckhouses or less than those required by *Pt 3, Ch 8, 2 Scantlings of erections other than forecastles* for an exposed machinery casing.

Table 4.5.1 Superstructures and deckhouses on forecastle deck

Position	Thickness of plating, in mm	Modulus of stiffeners, in cm ³	Depth of stiffeners, in mm
Fronts	The greater of $t = 0,012s$ or 8,0	$Z = 0,034sl_e^2$	Not less than 100
Sides	The greater of $t = 0,01s$ or 6,5	$Z = 0,027sl_e^2$	Not less than 75
Aft ends	The greater of $t = 0,008s$ or 6,5	$Z = 0,027sl_e^2$	Not less than 65

Note The ends of stiffeners are to be connected on all tiers.

■ *Section 6*
Miscellaneous openings

6.1 General

6.1.1 For offshore supply ships the requirements of *Pt 3, Ch 11, 6 Miscellaneous openings* are to be complied with.

6.2 Access from freeboard deck

6.2.1 There is to be no direct access from the freeboard deck to machinery or other spaces below the freeboard deck. Indirect access may be arranged via a space or passageway fitted with an outer door having a sill not less than 600 mm high and an inner door having a sill not less than 380 mm high. The inner door is to be self-closing and gastight. The space or passageway between the two doors is to be adequately drained. It is desirable, however, that access to spaces below the freeboard deck is arranged from a position above the superstructure deck. Where it is necessary to provide an emergency escape trunk which cannot terminate within a superstructure space, the arrangements for maintaining the integrity of the hatch or outlet are to be approved by Lloyd's Register (hereinafter referred to as 'LR').

6.3 Windows and side scuttles

6.3.1 The requirements of this Section are to be applied in conjunction with *Pt 3, Ch 11, 6.5 Side scuttles, windows and skylights*.

6.3.2 Windows may only be fitted in the following locations:

- (a) Second tier and higher above the freeboard deck:
 - (i) in the after end bulkhead of deckhouses and superstructures,
 - (ii) in the sides of deckhouses and superstructures which are not part of the shell plating.
- (b) Third tier and higher above the freeboard deck:
 - (i) in the forward facing bulkheads of deckhouse and superstructures, except that in the first tier of the front bulkhead above the weather deck, only side scuttles will be accepted.

6.3.3 In locations not specified in *Pt 4, Ch 4, 6.3 Windows and side scuttles 6.3.2*, only side scuttles will be accepted.

6.3.4 Permanently attached deadlights are to be provided as follows:

- (a) Side scuttles:
 - (i) in the side shell plating,
 - (ii) in the forward facing bulkheads of superstructures and deckhouses,
 - (iii) in the sides of deckhouses and superstructures up to and including the third tier above the freeboard deck,

(iv) in the after end bulkheads of superstructures, deckhouses, casings and companionways in the first and second tiers above the freeboard deck.

(b) Windows in locations permitted in *Pt 4, Ch 4, 6.3 Windows and side scuttles 6.3.2*:

- (i) in the sides of deckhouses and superstructures in the second and third tiers above the freeboard deck.
- (ii) in the after end bulkheads of superstructures, deckhouses, casings and companionways in the second tier above the freeboard deck.

6.3.5 On windows in the second tier and higher above the freeboard deck, hinged storm covers may be fitted in lieu of deadlights, provided there is safe access for closing.

6.3.6 Windows in the wheelhouse front are to have deadlights or storm covers. For storm covers, an arrangement for easy and safe access is to be provided, (e.g. gangway with railing). However, for practical purposes, the deadlights or storm covers may be portable if stowed adjacent to the window for quick fitting. At least two of the deadlights or storm covers are to have the means of providing a clear view.

6.3.7 Deadlights for side scuttles, and for windows not mentioned in *Pt 4, Ch 4, 6.3 Windows and side scuttles 6.3.5* and *Pt 4, Ch 4, 6.3 Windows and side scuttles 6.3.6*, are to be internally hinged.

6.3.8 Side scuttles are to comply with ISO Standard 1751, as follows:

- (a) Type A side scuttles in the shell plating, in the sides of superstructures and in the forward facing bulkheads of superstructures and deckhouses on the weather deck;
- (b) Type B side scuttles in the after ends of superstructures and in the sides and ends of deckhouses; or
- (c) An equivalent National Standard.

6.3.9 For the location of windows and side scuttles, see *Figure 4.6.1 Location of windows and side scuttles*.

6.3.10 The thickness of the toughened safety glass for windows is to be not less than the greater of:

(a)

$$t = 10 \text{ mm}$$

(b)

$$t = b \sqrt{\frac{H_d \beta}{4000}} \text{ mm}$$

where

H_d = design pressure head, in metres, as obtained from *Table 4.6.1 Design pressure head, H_d , on windows*

b = length of shorter side of window, in mm

$$\beta = 0,54A_R - 0,078A_R^2 - 0,17 \text{ for } A_R \leq 3$$

$$= 0,75 \text{ for } A_R > 3$$

A_R = aspect ratio of window

$$= a/b$$

a = length of longer side of window, in mm.

6.3.11 Proposals for alternative materials will be specially considered.

Table 4.6.1 Design pressure head, H_d , on windows

	Design pressure head, in metres	
	Windows in front and side bulkheads	Windows in after end bulkheads
6th tier and above	3,0	2,5
5th tier	5,0	2,5

4th tier	8,0	2,5
3rd tier	12,5	6,25
2nd tier	14,0	8,0

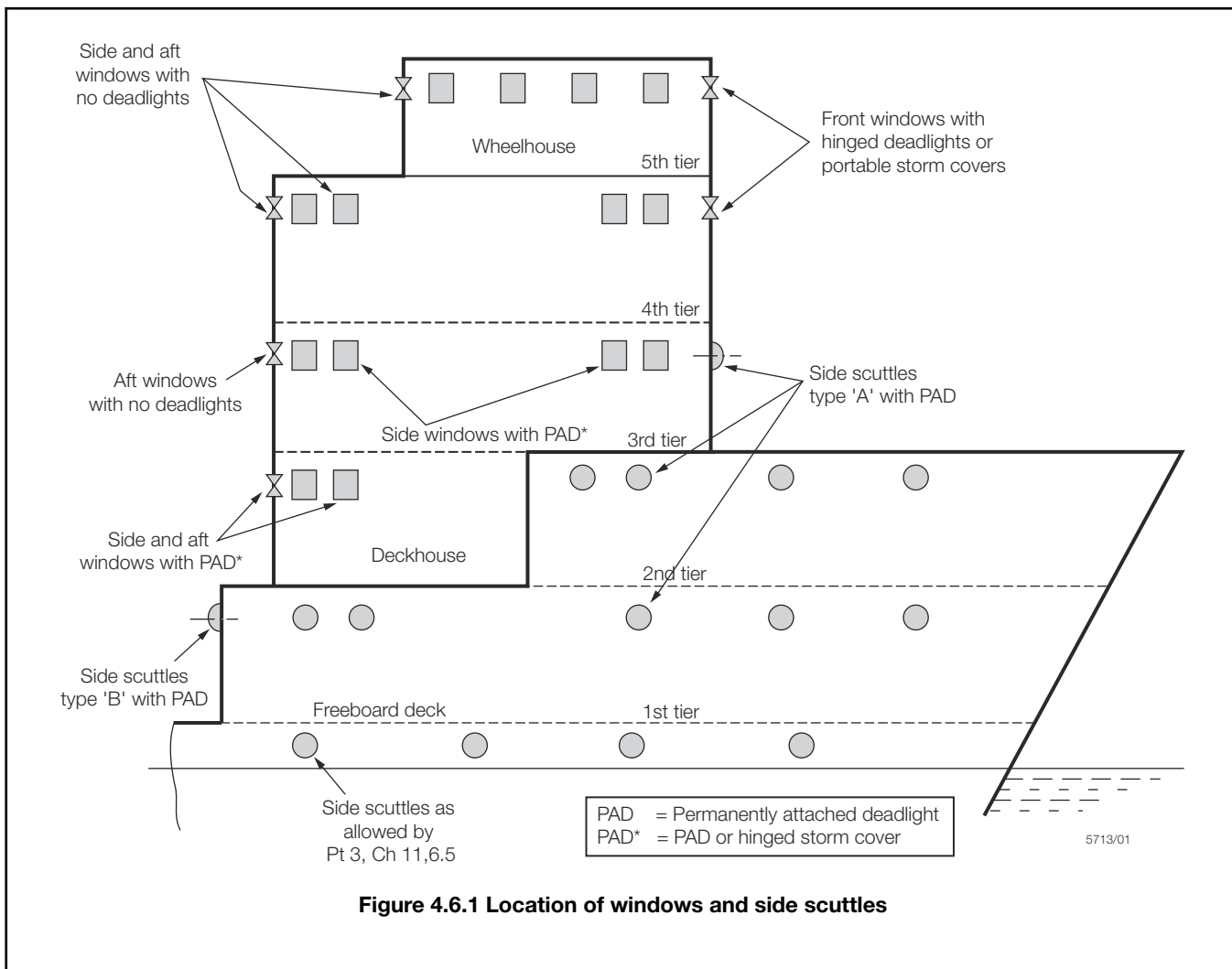

Figure 4.6.1 Location of windows and side scuttles

■ *Section 7*
Engine exhaust outlets

7.1 Location

7.1.1 Engine exhaust outlets are to be located as high as is practicable above the deck and are to be fitted with spark arresters.

■ *Section 8*

Transport and handling of limited amounts of hazardous and noxious liquid substances in bulk

8.1 General

8.1.1 The requirements of this Section are, in general, to be complied with unless they are waived or substituted by requirements mandated by the Administration.

8.1.2 This Section applies to the arrangement and scantling of sea-going ships as defined in *Pt 4, Ch 4, 1.1 Application* and intended for the carriage of:

- the aggregate quantity of bulk liquids identified in *Pt 4, Ch 4, 8.1 General 8.1.3* that is carried is any amount not exceeding a maximum which is the lesser of 800 m³ or a volume in cubic metres equal to 40 per cent of the vessel's deadweight calculated at a cargo density of 1,0.

8.1.3 Products which may be carried are:

(a) hazardous and noxious liquids listed in *Table 4.8.1 Table of permitted cargoes* and those other products which may be assigned to *Table 4.8.1 Table of permitted cargoes* based on the following criteria:

- products which for safety reasons may be assigned for carriage on a type 3 ship as defined by the *Rules and Regulations for the Construction and Classification of Ships for the Carriage of Liquid Chemicals in Bulk* (hereinafter referred to as Rules for Ships for Liquid Chemicals) and which are not required to meet the requirements for toxic products in *Ch 1, 15.12 Toxic products* of the Rules for Ships for Liquid Chemicals;
- noxious liquid substances which would be permitted for carriage on a type 3 ship;

(b) flammable liquids (liquids having a flashpoint not exceeding 60°C (closed-cup test)).

8.1.4 Carriage of products not listed in *Table 4.8.1 Table of permitted cargoes* should only be undertaken in accordance with suitable preliminary carriage conditions and the limitation referred to in *Pt 4, Ch 4, 8.1 General 8.1.3*.

8.1.5 Additives which are considered to fall outside the scope of products in *Pt 4, Ch 4, 8.1 General 8.1.3* may be carried in limited amounts. The aggregate amount of such additives which may be transported should not exceed 10 per cent of the vessel's maximum authorised quantity of products subject to this Section. An individual tank should contain not more than 10 m³ of these additives. The discharge of these additives into the sea from offshore support vessels is prohibited.

8.1.6 Ships complying with the requirements of this section will be eligible for the special feature notation **HNLS**.

Table 4.8.1 Table of permitted cargoes

Cargo	Flammability	Hazard
Oil-based mud containing mixtures of products listed in <i>Chapter 17 Summary of minimum requirements</i> and <i>Chapter 18 List of products to which the Code does not Apply</i> of the IBC Code and the MEPC.2/Circular and permitted to be carried under paragraph 8.1	No	–
Water-based mud containing mixtures of products listed in <i>Chapter 17 Summary of minimum requirements</i> and <i>Chapter 18 List of products to which the Code does not Apply</i> of the IBC Code and the MEPC.2/Circular and permitted to be carried under paragraph 8.1	No	–
Drilling Brines, including:	No	
Sodium Chloride Solution	No	P
Calcium Bromide Solution	No	P
Calcium Chloride Solution	No	P
Calcium nitrate/Magnesium nitrate/Potassium chloride solution	No	P
Calcium Nitrate Solution (50% or less)	No	P
Drilling brines (containing zinc salts)	No	P

Potassium Formate Solution	No	P
Potassium Chloride Solution	No	S/P
Ethyl Alcohol	Yes	P
Ethylene Glycol	No	P
Ethylene Glycol monoalkyl ether	Yes	S/P
Methyl Alcohol	Yes	P
Acetic acid	Yes	S/P
Formic acid	Yes	S/P
Hydrochloric Acid	No	S/P
Hydrochloric-hydrofluoric mixtures containing 3% or less Hydrofluoric acid	No	S/P
Sodium Silicate Solution	No	P
Sulphuric Acid	No	S/P
Triethylene Glycol	No	P
Toluene	Yes	P
Xylene	Yes	P
Liquid carbon dioxide	No	S
Liquid nitrogen	No	S
Noxious liquid, NF, (7) n.o.s. (trade name ..., contains ...) ST3, Cat. Y	No	P
Noxious liquid, F, (8) n.o.s. (trade name, contains ...) ST3, Cat. Y	Yes	P
Noxious liquid, NF, (9) n.o.s. (trade name ..., contains ...) ST3, Cat. Z	No	P
Noxious liquid, F, (10) n.o.s. (trade name ..., contains ...) ST3, Cat. Z	Yes	P
Noxious liquid, (11) n.o.s. (trade name ..., contains ...) Cat. Z	No	P
Non-noxious liquid, (12) n.o.s. (trade name ..., contains ...) Cat. OS	No	P

8.2 Definitions

8.2.1 Cargo area is that part of the offshore supply ship where cargo and cargo vapours are likely to be present and includes cargo tanks, cargo pump-rooms, hold spaces in which independent tanks are located, cofferdams surrounding integral tanks and the following deck areas:

- within 3 m of a cargo tank installed on deck;
- within 3 m of a cargo tank outlet in case of independent tanks installed below deck;
- within 3 m of a cargo tank outlet in case of integral tanks installed below deck and separated from the weather deck by a cofferdam;
- the deck area above an integral tank without an overlaying cofferdam plus the deck area extending transversely and longitudinally for a distance of 3 m beyond each side of the tank;
- within 3 m of any cargo liquid or vapour pipe, flange, cargo valve, gas or vapour outlet, or entrance or ventilation opening to a cargo pump-room.

8.2.2 Deadweight means the difference in metric tons between the displacement of an offshore support vessel in water of a density of 1,025 at the load waterline corresponding to the assigned summer freeboard and the lightweight of the ship.

8.2.3 Lightweight means the displacement of an offshore support vessel in metric tons without cargo, fuel, lubricating oil, ballast water, fresh water and feed water in tanks, consumable stores, and passengers and crew and their effects.

8.2.4 Hazardous substance is any substance either listed in *chapter 17* of the Rules for Ships for Liquid Chemicals or having a hazard more severe than one of the minimum hazard criteria given in criteria for hazard evaluation of bulk chemicals as approved by the Organisation.

8.2.5 Pollution hazard only substance means a substance having an entry only of "P" in column d in *chapter 17* of the Rules for Ships for Liquid Chemicals.

8.2.6 Safety hazard substance means a substance having an entry of 'S' or 'S/P' in column d in *chapter 17* of the Rules for Ships for Liquid Chemicals.

8.2.7 Flammable liquid is any liquid having a flashpoint not exceeding 60°C (closed-cup test).

8.3 Cargo tank location

8.3.1 Cargo tanks should be located at least 760 mm measured inboard from the side of the vessel perpendicular to the centreline at the level of the summer load waterline.

8.4 Cargo segregation

8.4.1 Tanks containing cargo or residues of cargo should be segregated from machinery spaces, propeller shaft tunnels, if fitted, dry cargo spaces, accommodation and service spaces and from drinking water and stores for human consumption, by means of a cofferdam, void space, cargo pump-room, empty tank, fuel oil tank, or other similar space. On-deck stowage of independent tanks or installing independent tanks in otherwise empty hold spaces should be considered as satisfying this requirement.

8.4.2 Cargoes which react in a hazardous manner with other cargoes or fuel oils should:

- be segregated from such other cargoes or fuel oils by means of a cofferdam, void space, cargo pump-room, empty tank, or tank containing a mutually compatible cargo;
- have separate pumping and piping systems which should not pass through other cargo tanks containing such cargoes, unless encased in a tunnel; and
- have separate tank venting systems.

8.4.3 Cargo piping should not pass through any accommodation, service or machinery space other than cargo pump-rooms or pump-rooms.

8.4.4 Pumps, ballast lines, vent lines and other similar equipment serving permanent ballast tanks should be independent of similar equipment serving cargo tanks.

8.4.5 Bilge pumping arrangements for cargo pump-rooms or for hold spaces in which independent cargo tanks are installed should be situated entirely within the cargo area.

8.5 Segregation requirements for integral tanks

8.5.1 Where not bounded by bottom shell plating, fuel oil tanks, a cargo pump-room or a pump-room, the cargo tanks should be surrounded by cofferdams. Tanks for other purposes (except fresh water and lubricating oils) may be accepted as cofferdams for these tanks.

8.5.2 For access to all spaces, the minimum spacing between cargo tank boundaries and adjacent ship's structures should be 600 mm.

8.5.3 Cargo tanks may extend to the deck plating, provided dry cargo is not handled in that area. Where dry cargo is handled on the deck area above a cargo tank, the cargo tank may not extend to the deck plating unless a continuous, permanent deck sheathing of wood or other suitable material of appropriate thickness and construction is fitted.

8.5.4 Cargoes subject to the scope of products in *Pt 4, Ch 4, 8.1 General 8.1.2* and *Pt 4, Ch 4, 8.1 General 8.1.3* should not be carried in either the fore or aft peak tanks.

8.5.5 For pollution hazard only substances having a flashpoint exceeding 60°C (closed-cup test) the arrangements referred to in *Pt 4, Ch 4, 8.4 Cargo segregation 8.4.1* and *Pt 4, Ch 4, 8.4 Cargo segregation 8.4.3* need not be applied provided that the segregation requirements for accommodation spaces, drinking water and stores for human consumption are satisfied. Additionally, *Pt 4, Ch 4, 8.5 Segregation requirements for integral tanks 8.5.1* and *Pt 4, Ch 4, 8.5 Segregation requirements for integral tanks 8.5.2* need not be applied.

8.6 Accommodation, service and machinery spaces and control stations

8.6.1 Accommodation or service spaces, or control stations should not be located within the cargo area.

8.6.2 Unless they are spaced at least 7 m away from the cargo area containing flammable products, entrances, air inlets and openings to accommodation, service and machinery spaces and control stations should not face the cargo area. Doors to spaces not having access to accommodation, service and machinery spaces and control stations, such as cargo control stations and store-rooms, may be permitted within the 7 m zone specified above, provided the boundaries of the spaces are insulated to A-60 Standard and each case will be specially considered. When arranged within the 7 m zone specified above, windows and side scuttles facing the cargo area should be of a fixed type. Such side scuttles in the first tier on the maindeck should be fitted with inside covers of steel or equivalent material.

8.6.3 In order to guard against the danger of hazardous vapours, due consideration should be given to the location of air intakes and openings into accommodation, service and machinery spaces and control stations in relation to cargo piping and cargo vent systems.

8.6.4 For pollution hazard only substances having a flashpoint exceeding 60°C, the arrangements referred to in *Pt 4, Ch 4, 8.6 Accommodation, service and machinery spaces and control stations 8.6.1 to Pt 4, Ch 4, 8.6 Accommodation, service and machinery spaces and control stations 8.6.3* may be waived.

8.7 Access to spaces in the cargo areas

8.7.1 Access to spaces within the cargo area should meet the requirements of *Ch 1, 3.4 Access to spaces in the cargo area* of the Rules for Ships for Liquid Chemicals.

8.8 Cargo tank construction

8.8.1 Cargo tanks are to be as required by the *18 Rules and Regulations for the Construction and Classification of Ships for the Carriage of Liquefied Gases in Bulk, July 2015* (hereinafter referred to as Rules for Ships for Liquefied Gases) or Rules for Ships for Liquid Chemicals as applicable and for the intended cargo.

8.8.2 Instead of the use of permanently attached decktanks, portable tanks meeting the requirements of the International Dangerous Goods (IMDG) Code or other portable tanks specially approved may be used for cargoes indicated in *Pt 4, Ch 4, 8.1 General 8.1.3*, provided that the tanks are properly located and secured to the vessel.

8.8.3 Except for the tank connections to cargo pump-rooms, all tank openings and connections to the tank should terminate above the weather deck and should be located in the tops of the tanks. Where cofferdams are provided over integral tanks, small trunks may be used to penetrate the cofferdam.

8.8.4 The greater of the following design pressures (gauge) should be used for determining scantlings of independent pressure tanks:

- 0,07 MPa;
- the vapour pressure of the cargo at 45°C;
- the vapour pressure of the cargo at 15°C above the temperature at which it is normally carried; or
- the pressure which occurs in the tank during the loading or unloading.

The design of the tanks should comply with acceptable standards taking into account the carriage temperature and relative density of cargo. Due consideration should also be given to dynamic forces and any vacuum pressure to which the tanks may be subjected.

8.8.5 Integral and independent gravity tanks should be constructed and tested according to acceptable standards taking into account the carriage temperature and relative density of cargo.

8.8.6 For pollution hazard only substances having a flashpoint exceeding 60°C, the requirements of *Pt 4, Ch 4, 8.8 Cargo tank construction 8.8.3* need not be applied.

8.9 Materials of construction

8.9.1 Materials of construction for tanks, piping, fittings and pumps should be in accordance with *Materials of Construction and welding* of the Rules for Ships for Liquid Chemicals, or *chapter 6* of the Rules for Ships for Liquefied Gases, as applicable.

8.10 Cargo tank vent systems

8.10.1 Independent pressure tanks should be fitted with pressure relief devices that are so designed as to direct the discharge away from personnel and that have a set pressure and capacity which is in accordance with acceptable standards taking into account the design pressure referred to in *Pt 4, Ch 4, 8.8 Cargo tank construction 8.8.4*.

8.10.2 Cargo tank vent systems of integral or independent gravity tanks should meet the requirements of the Rules for Ships for Liquid Chemicals, except that the height specified in *Ch 1, 8.3 Types of tank venting systems* of those Rules may be reduced to 2 m.

8.10.3 The location of cargo tank vent outlets for independent pressure tanks and for cargo tanks used to carry pollution hazard only substances with a flashpoint exceeding 60°C (closed-cup test) should be to the satisfaction of LR.

8.10.4 Cargo tank vent systems of portable tanks allowed under *Pt 4, Ch 4, 8.8 Cargo tank construction 8.8.2* should be to the satisfaction of LR, taking into account the requirements of *Pt 4, Ch 4, 8.10 Cargo tank vent systems*.

8.11 Cargo transfer

8.11.1 The cargo transfer system should comply with the requirements of *Cargo Transfer* of the Rules for Ships for Liquid Chemicals, or the *18, Ch 5 Process Pressure Vessels and Liquid, Vapour and Pressure Piping Systems*, when considered applicable and practical, taking into account existing industry standards and practices.

8.11.2 The remote shutdown devices for all cargo pumps and similar equipment, required by *Ch 1, 5.6 Cargo transfer control systems* of the Rules for Ships for Liquid Chemicals, should be capable of being activated from a dedicated cargo control location which is manned at the time of cargo transfer and from at least one other location outside the cargo area and at a safe distance from it.

8.12 Electrical installations

8.12.1 Electrical installations should meet the requirements of *Electrical Installations* of the Rules for Ships for Liquid Chemicals.

8.13 Acid spill protection

8.13.1 Floors or decks under acid storage tanks and pumps and piping for acid should have a lining or coating of corrosion-resistant material extending up to a minimum height of 500 mm on the bounding bulkheads or coamings. Hatches or other openings in such floors or decks should be raised to a minimum height of 500 mm; however, where this height is not practicable a lesser height may be required.

8.13.2 Flanges or other detachable pipe connections should be covered by spray shields.

8.13.3 Portable shield covers for connecting the flanges of the loading manifold should be provided. Drip trays of corrosion-resistant material should be provided under loading manifolds for acids.

8.13.4 Spaces for acid storage tanks and acid pumping and piping should be provided with drainage arrangements of corrosion-resistant materials.

8.13.5 Deck spills should be kept away from accommodation and service areas by means of a permanent coaming of suitable height and extension.

8.14 Ventilation of spaces in the cargo area

8.14.1 The requirements of *Mechanical Ventilation in the Cargo Area* of the Rules for Ships for Liquid Chemicals are to be applied. Consideration will be given to requests for relaxation of requirements concerning the distance required in *Ch 1, 12.1 Spaces normally entered during cargo-handling operations 12.1.5* of the Rules for Ships for Liquid Chemicals.

8.15 Vapour detection

8.15.1 Vapour detection for the cargoes carried should be provided in accordance with the requirements contained in the Rules for Ships for Liquid Chemicals.

8.15.2 Enclosed and semi-enclosed spaces containing installations for acid should be fitted with fixed vapour detection and alarm systems which provide visual and audible indication. The vapour detection systems should be capable of detecting hydrogen except that, in the case where only hydrochloric acid is carried, a hydrogen chloride vapour detection system should be provided.

8.15.3 At least two portable instruments for detecting flammable vapour concentrations should be provided when cargoes subject to the requirements of this Section (see *Pt 4, Ch 4, 8.1 General 8.1.3*) with a flashpoint not exceeding 60°C (closed-cup test) are carried.

8.15.4 At least two portable instruments suitable for measuring the concentration of oxygen in atmospheric air should be provided.

8.16 Special requirements

8.16.1 The special requirements for the cargo as referred to in *Summary of Minimum Requirements* of the Rules for Ships for Liquid Chemicals or *chapter 19* of the Rules for Ships for Liquefied Gases are applicable; however, the requirement in *Ch 1, 15.19 Overflow control* of the Rules for Ships for Liquid Chemicals for a visual and audible high-level alarm may be waived taking into account the cargo carriage arrangements and cargo loading procedures and each case will be specially considered.

8.17 Special requirements for the carriage of liquified gases

8.17.1 Each enclosed space used for handling or storage of a liquefied gas should be fitted with a sensor continuously monitoring the oxygen content of the space and an alarm indicating low oxygen concentration. For semi-enclosed spaces portable equipment may also be acceptable.

8.17.2 Drip trays resistant to cryogenic temperatures should be provided at manifolds transferring liquefied gases or at other flanged connections in the liquefied gas system.

8.17.3 For the carriage of liquid nitrogen the requirements of *17.19* of the Rules for Ships for Liquefied Gases are to be applied.

8.17.4 The construction of cargo tanks and cargo piping systems for liquefied nitrogen and liquid carbon dioxide should be to the satisfaction of LR.

8.17.5 Emergency shut-off valves should be provided in liquid outlet lines from each liquefied gas tank. The controls for the emergency shut-off valves should meet the requirements given in *Pt 4, Ch 4, 8.10 Cargo tank vent systems 8.10.2* for remote shutdown devices.

8.18 Gauging and level detection

8.18.1 Each cargo tank should have a level gauging system in accordance with the Rules for Ships for Liquefied Gases or Rules for Ships for Liquid Chemicals as applicable.

8.19 Emergency remote shutdown

8.19.1 In the case of transfer operations involving pressures in excess of 5 MPa, arrangements for emergency depressurising and disconnection of the transfer hose should be provided. The controls for activating emergency depressurisation and disconnection of the transfer hose should meet the requirements given in *Pt 4, Ch 4, 8.11 Cargo transfer 8.11.2* for remote shutdown devices.

8.20 Pollution requirements

8.20.1 Each ship certified to carry noxious liquid substances should be provided with a Cargo Record Book, a Procedure and Arrangements Manual and a Shipboard Marine Emergency Plan developed for the ship in accordance with *Annex II of MARPOL 73/78 Regulations for the Control of Pollution by Noxious Liquid Substances in Bulk* to MARPOL 73/78 and approved.

8.20.2 Discharge into the sea of residues of noxious liquid substances permitted for the carriage in Ship Type 3, or products listed in *Pt 4, Ch 4, 8.1 General 8.1.2* or ballast water, tank washings, or other residues or mixtures containing such substances, is prohibited. Any discharges of residues and mixtures containing noxious liquid substances should be to reception facilities in port. As a consequence of this prohibition, the requirements for efficient stripping and underwater discharge arrangements in MARPOL 73/78, *Annex II of MARPOL 73/78 Regulations for the Control of Pollution by Noxious Liquid Substances in Bulk* may be waived.

8.20.3 In the case of cargoes regulated by MARPOL 73/78, *Annex I of MARPOL 73/78 Regulations for the Prevention of Pollution by Oil*, the requirements of that Annex should apply as appropriate.

8.21 Decontamination showers and eyewashes

8.21.1 Except in the case of pollution hazard only substances, a suitably marked decontamination shower and eyewash should be available on deck in a convenient location. The shower and eyewash should be operable in all ambient conditions.

8.22 Protective and safety equipment

8.22.1 Protective and safety equipment should be kept on board in suitable locations as required by *chapter 14* of the Rules for Ships for Liquefied Gases or *Personnel Protection* of the *Rules and Regulations for the Construction and Classification of Ships for the Carriage of Liquid Chemicals in Bulk, July 2015* for products to be carried.

**■ Section 9
Standby ship****9.1 Application and definitions**

9.1.1 The requirements in this Section apply to standby ships. A standby ship is a sea-going ship designed, constructed, organised and maintained in such a way that she can give assistance in the event of an emergency on or near an offshore installation.

9.1.2 The National Authority with whom the ship is registered and/or the Administration within whose territorial jurisdiction the ship is intended to operate may have requirements for the same items as required by these Rules. In those instances the more onerous requirements are to be applied.

9.2 Configuration of standby ship

9.2.1 The main features of standby ships which dictate the structural configuration are:

- (a) Designated and illuminated winching area for helicopter operations.
- (b) Clearly marked and lighted rescue zone at the side of the ship.
- (c) Survivors area.
- (d) Fast rescue boat.

9.3 Information required

9.3.1 In addition to the information and plans required by *Pt 4, Ch 4, 1.3 Information required*, details of local strengthening of the following items are to be submitted where applicable:

- (a) The arrangement and integration into the hull of equipment, supports, foundations for rescue equipment, etc. in conjunction with their weight, working load and holding capability information.
- (b) Support for towing arrangement as applicable.
- (c) The arrangement for the fast rescue craft.

9.4 Equipment foundations

9.4.1 When considering the loads, all expected directions of operation are to be taken into account.

9.4.2 The foundation for towing equipment, if applicable, is to be in accordance with *Pt 4, Ch 3, 7.2 Towing equipment foundations*.

9.5 Ship Arrangement

9.5.1 For standby ships the rescue arrangement, accommodation and facilities for survivors and safety equipment is required to comply with a National Standard. The applicable Certificate or Statement of Compliance with a National Standard is to be issued by a National Administration, or by LR, or by an IACS member when so authorised. Where no national requirements exist for a particular vessel, LR will issue statement of compliance with UKOOA.

■ Section 10**Anchor handler****10.1 Application and definitions**

10.1.1 The requirements of this Section apply to ships specially designed, constructed and equipped for handling anchors of a floating offshore installation.

10.2 Structural configuration

10.2.1 The main features of an anchor handler which dictate the structural configurations are:

- (a) The ship has a completely clear after deck in order to handle the anchors effectively.
- (b) One or more winches designed for the purpose of deploying and recovering the anchors.
- (c) Large horizontal stern roller, if fitted. During the anchorhandling process the ship is often required to take the anchors on board by hauling them over her stern, along with their associated chain and other fittings. For this purpose a large horizontal roller is installed in the stern, usually at deck level.
- (d) A rounded form in way of the area for shipping/unshipping anchors at stern.
- (e) Chain lockers under the main winch, if fitted. Anchor handlers are sometimes required to store rig or mooring chain and, for this purpose, most are fitted with chain lockers under the main winch which double as ballast or brine tanks when not in use.
- (f) Equipment for temporary securing of the anchor e.g. shark's jaw.
- (g) Towing pins in way of the stern roller.
- (h) High duty bollards.

10.3 Information required

10.3.1 In addition to the information and plans required by *Pt 4, Ch 4, 1.3 Information required*, details of local strengthening of the following items are to be submitted where applicable:

- (a) The arrangement and integration into the hull of equipment, tanks, supports, foundations, etc. in conjunction with their weight, working load and holding capability information.
- (b) For unusual structural arrangement and equipment, calculations are to be submitted showing acceptable structural strength.
- (c) Supports and foundations for anchor handling and laying arrangements for anchors carried as cargo.

10.4 Hull envelope plating

10.4.1 Anchor handling activities often give rise to areas of high local loads and/or frequent impacts, such as in way of stern rollers and immediately adjacent to high duty bollards. The shell in way of high loads and/or frequent impacts is to be suitably reinforced by increasing shell plate thickness, additional stiffening support or other appropriate means.

10.5 Working deck

10.5.1 Deck areas, where there are arrangements for the collection and handling of anchors and associated equipment, are to be protected by wooden sheathing. Alternatively, this can be omitted if the plate thickness is increased by 2,5 mm.

10.6 Equipment foundations

10.6.1 When considering the loads, all expected directions of operation are to be taken into account. The foundation for deck equipment (winch, stern roller, etc.) is to be in accordance with *Pt 4, Ch 3, 7.2 Towing equipment foundations* as applicable.

Section

- 1 **General**
- 2 **Longitudinal strength**
- 3 **Hull envelope plating**
- 4 **Hull envelope framing**
- 5 **Strengthening of bottom forward**
- 6 **Bottom strengthening for loading and unloading aground**
- 7 **Watertight bulkheads**
- 8 **Void spaces**

■ **Section 1**
General

1.1 Application

1.1.1 This Chapter applies, in general, to manned or unmanned non-self-propelled ships defined as follows:

- (a) Barges for the carriage of general dry cargoes in cargo holds.
- (b) Barges for the carriage of liquid cargoes in bulk.
- (c) Pontoons designed specifically for the carriage of non-perishable cargo on deck.
- (d) Shipborne barges for the carriage of general dry cargo in cargo holds and intended to operate afloat only within specified geographical limits, and suitable for regular carriage on board a larger ship.

1.1.2 Manned or unmanned barges for the carriage of liquid chemicals in bulk and barges for the carriage of liquefied gases will receive individual consideration on the basis of the Rules, see *Table 5.1.1 Applicable Rules*.

Table 5.1.1 Applicable Rules

Type of barge	Applicable Rules
Barge for the carriage of general dry cargo in cargo hold	<i>Pt 4, Ch 1 General Cargo Ships</i>
Barge for the carriage of liquid cargo in bulk	<i>Pt 4, Ch 10 Single Hull Oil Tankers</i>
Pontoon designed specifically for the carriage of non-perishable cargo on deck	<i>Pt 4, Ch 1 General Cargo Ships</i>
Shipborne barges for the carriage of general dry cargo in cargo holds	<i>Pt 4, Ch 1 General Cargo Ships</i> and this Chapter for 'extended protected water service' barges
Barge for the carriage of liquid chemicals in bulk	<i>Rules and Regulations for the Construction and Classification of Ships for the Carriage of Liquid Chemicals in Bulk, July 2015</i>
Barge for the carriage of liquefied gases	<i>18 Rules and Regulations for the Construction and Classification of Ships for the Carriage of Liquefied Gases in Bulk, July 2015</i>

1.1.3 The scantlings and arrangements, except where otherwise specified in this Chapter, are to comply with the Rules as indicated in *Table 5.1.1 Applicable Rules*.

1.1.4 The Rules assume that the structural arrangements of barges carrying cargo in holds will generally approximate to normal ship shape and construction. Barges of this type not doing so will receive individual consideration on the basis of the Rules.

1.1.5 The Rules also assume that barges and pontoons are homogeneously loaded. Barges or pontoons with other types of loading, e.g. crane pontoon, will receive individual consideration.

1.1.6 All barges and pontoons are to be fitted with adequate arrangements for towing. In general, such arrangements are to consist of, or be equivalent to, not less than two sets of bollards, each of which shall be suitable for accepting a towline of suitable breaking strength.

1.2 Class notations

1.2.1 In general, ships complying with the requirements of this Chapter will be eligible for one of the following classes:

- (a) **100A1 barge.** This class will be assigned to non-self-propelled sea-going ships as defined in *Pt 4, Ch 5, 1.1 Application 1.1.1.*
- (b) **100A1 oil barge.** This class will be assigned to non-self-propelled sea-going ships as defined in *Pt 4, Ch 5, 1.1 Application 1.1.1.*
- (c) **100A1 pontoon.** This class will be assigned to non-self-propelled sea-going ships as defined in *Pt 4, Ch 5, 1.1 Application 1.1.1.*

1.2.2 Barges and pontoons intended to be operated only in suitable areas or conditions which have been agreed by the Committee, as defined in *Pt 1, Ch 2, 2.3 Class notations (hull) 2.3.6 to Pt 1, Ch 2, 2.3 Class notations (hull) 2.3.10*, will receive individual consideration on the basis of the Rules with respect to the environmental conditions agreed for the design basis and approval. In particular, shipborne barges as defined in *Pt 4, Ch 5, 1.1 Application 1.1.1* complying with the requirements of this Chapter will be eligible to be classed **100A1 shipborne barge extended protected water service**.

1.2.3 The Regulations for classification and the assignment of class notations are given in *Pt 1, Ch 2 Classification Regulations*, to which reference should be made.

1.3 Information required

1.3.1 In addition to the information and plans required by *Pt 3, Ch 1, 5 Information required*, the following are to be submitted:

- Details of structure and fittings to which deck cargo securing lashings, etc. are attached.
- Details of the bollards and their supporting structure.
- Where pusher tugs or integral tug/barge systems are proposed, full details and data of the attachment and support arrangements.
- Details of the intended service areas required for barges or pontoons designed to operate within specified geographical limits.
- Longitudinal strength and lifting arrangements for ship-borne barges.

1.4 Symbols and definitions

1.4.1 The Rule length, L , for vessels with swim ends is to be measured as shown in *Figure 5.1.1 Definition of Rule length*. Where a swim end is arranged aft but no rudder is fitted, L need not exceed 97 per cent of the extreme length on the summer load waterline. For tugs and barge units having rigid connections, the length, L , is to be taken as the combined length of the tug and barge.

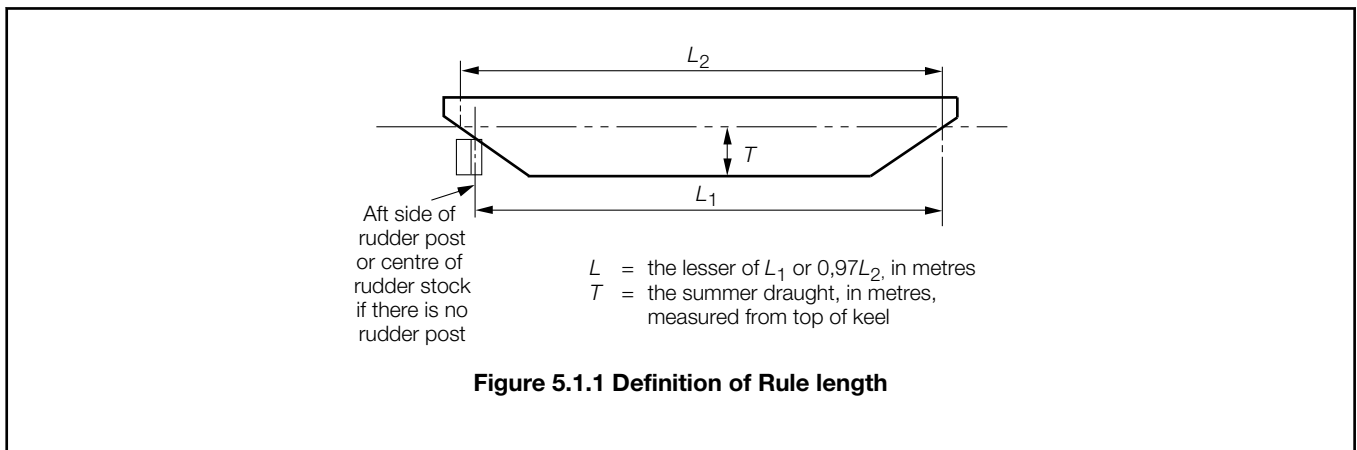

■ **Section 2**
Longitudinal strength

2.1 General

2.1.1 Longitudinal strength calculations are to be made in accordance with the requirements given in *Pt 3, Ch 4 Longitudinal Strength*, and the ship service factor, f_1 , is given in *Table 5.2.1 Ship service factor f_1* .

Table 5.2.1 Ship service factor f_1

Type of ship	f_1	
	'100A1'	'100A1 extended protected water service'
Barge for the carriage of general cargo in holds and for the carriage of liquid cargoes in bulk	1,0	0,80
Pontoons for the carriage of non-perishable cargoes on deck		
Shipborne barges for the carriage of general cargo in holds and unmanned	—	0,70

2.1.2 The requirements of *Pt 3, Ch 4, 8.3 Loading instrument* regarding loading instruments are not applicable to barges and pontoons.

2.1.3 For shipborne barges, where it is the intention to lift the barge on board ship by crane, a condition 'fully loaded barge suspended by crane' is to be submitted. For this condition the following stresses are permissible:

- Bending stress $\sigma_b = 147,2 \text{ N/mm}^2 (15,0 \text{ kgf/mm}^2)$
- Shear stress $\tau = 98,1 \text{ N/mm}^2 (10,0 \text{ kgf/mm}^2)$

■ **Section 3**
Hull envelope plating

3.1 Shell and deck plating

3.1.1 The thickness of shell and deck plating is to be as necessary to give the hull section modulus required by *Pt 4, Ch 5, 2.1 General* and to satisfy the requirements listed in *Table 5.3.1 Shell and deck plating*.

Table 5.3.1 Shell and deck plating

Item of plating	Thickness for ships classed 100A1	Thickness for ships having extended protected water service notation
(a) Keel	The separate requirements of <i>Pt 4, Ch 1 General Cargo Ships</i> or <i>Pt 4, Ch 10 Single Hull Oil Tankers</i> , whichever is applicable, for keel width and thickness need not be applied, except where $L > 100$ m and the bottom has a rise of floor	
(b) Bottom shell and bilge	In accordance with the requirements of <i>Pt 4, Ch 1 General Cargo Ships</i> or <i>Pt 4, Ch 10 Single Hull Oil Tankers</i> , whichever is applicable	In accordance with the requirements of <i>Pt 4, Ch 1 General Cargo Ships</i> or <i>Pt 4, Ch 10 Single Hull Oil Tankers</i> , whichever is applicable, reduced by 12,5 per cent, but is to be not less than required by (c) below
	For chines, see <i>Pt 4, Ch 5, 3.1 Shell and deck plating 3.1.2</i>	
(c) Side shell from upper turn of bilge or chine to deck	The greater of the values obtained from <i>Pt 4, Ch 1 General Cargo Ships</i> or <i>Pt 4, Ch 10 Single Hull Oil Tankers</i> , whichever is applicable, for the appropriate framing arrangement	
(d) Deck	In accordance with the requirements of <i>Pt 4, Ch 1 General Cargo Ships</i> or <i>Pt 4, Ch 10 Single Hull Oil Tankers</i> , whichever is applicable	In accordance with the requirements of <i>Pt 4, Ch 1 General Cargo Ships</i> or <i>Pt 4, Ch 10 Single Hull Oil Tankers</i> , whichever is applicable, reduced by 2 mm, but is to be not less than the deck basic end thickness as required by <i>Pt 3, Ch 5 Fore End Structure</i> and <i>Pt 3, Ch 6 Aft End Structure</i>
	In pontoon barges with deck cargoes the deck thickness derived from (d) may be required to be increased	
(e) Swim ends	The bottom shell plating thickness is to be maintained up to the summer load waterline for the rake plating. Above this point the thickness may be tapered to that of the side shell requirements from a point not less than 1 m above the load waterline	

3.1.2 On ships with two chines each side, the bilge plating should generally be calculated from the bottom plating formulae. On hard chine ships, flanged chines will not, in general, be approved, but where a chine is formed by knuckling the shell plating, the radius of curvature, measured on the inside of the plate, is to be not less than 10 times the plate thickness. Where a solid round chine bar is fitted, the bar diameter is to be not less than three times the thickness of the thickest abutting plate. Where welded chines are used, the welding is to be built up as necessary to ensure that the shell plating thickness is maintained across the weld.

■ **Section 4**
Hull envelope framing

4.1 Symbols

4.1.1 The symbols used in this Section are defined as follows:

- h = head or load height, in metres, and is to be taken as:
 - = for bottom longitudinals, frames, girders and transverses: the depth D
 - = for side longitudinals: the distance of the longitudinal below the deck at side, but not less than $0,01L + 0,7$
 - = for side transverses: the distance from the mid-point of span to the deck at side, but not less than $0,01L + 0,7$

= for deck longitudinals and transverses: the head equivalent to cargo carried at a stowage rate of 1,39 m³/tonne, but is not to be taken less than 0,01L + 0,7

= for side frames: the distance from the midpoint of span to the deck at the side

= for deck beams and girders: the head equivalent to cargo carried at a stowage rate of 1,39 m³/tonne, but is not to be taken less than required by *Table 3.5.1 Design heads and permissible cargo loadings*

l_e = effective length of stiffening member, in metres, see *Pt 3, Ch 3, 3 Structural idealisation*

s = spacing of frames, beams or longitudinals, in mm

S = spacing or mean spacing of girders, transverses or floors, in metres

Z = section modulus of stiffening member, in cm³, see *Pt 3, Ch 3, 3 Structural idealisation*.

4.2 General

4.2.1 Bottom, side and deck transverses are to be connected in such a manner as to ensure continuity of the transverse ring system, and longitudinals are to be attached to transverses. In way of deck and bottom transverses, a deep web frame is to be fitted.

4.2.2 End connections of longitudinals at bulkheads are to provide adequate fixity and direct continuity of longitudinal strength.

4.2.3 Brackets at the top and bottom of side frames are to extend to the adjacent deck or bottom longitudinal to which they are to be attached.

4.2.4 In pontoons where truss arrangements, comprising top and bottom girders in association with pillars and diagonal bracing, are used in the support of the deck loads, the diagonal members are generally to have angles of inclination with the horizontal of about 45° and cross-sectional area of approximately 50 per cent of the adjacent pillar in accordance with *Pt 4, Ch 1, 4.4 Deck supporting structure*, with a head in accordance with *Pt 4, Ch 1, 4.1 General 4.1.1*.

4.2.5 Adequate support must be provided on the centreline for the loads imposed on the structure when the ship is in dry dock.

4.3 Longitudinal framing

4.3.1 The scantlings of bottom, side and deck longitudinals are to comply with the requirements of *Table 5.4.1 Longitudinal framing*.

Table 5.4.1 Longitudinal framing

Position of longitudinals	Modulus, in cm ³
Bottom	* $Z = 11,0l_e^2 sh \times 10^{-3}$
Side shell	* $Z = 8,0l_e^2 sh \times 10^{-3}$
Deck	* $Z = 5,5l_e^2 sh \times 10^{-3}$
* For the requirements for barges carrying liquid cargoes in bulk see <i>Pt 4, Ch 10 Single Hull Oil Tankers</i>	
Note The scantlings derived from above need not exceed the scantling requirements of <i>Pt 4, Ch 1 General Cargo Ships</i> or <i>Pt 4, Ch 10 Single Hull Oil Tankers</i> , whichever is applicable.	

4.4 Transverse framing

4.4.1 The scantlings of bottom and side frames and deck beams are to comply with the requirements of *Table 5.4.2 Transverse framing*.

Table 5.4.2 Transverse framing

Position of member	Modulus, in cm ³
Bottom and side frames	* $Z = 9,5l_e^2 sh \times 10^{-3}$
Deck beams	* $Z = 4,5l_e^2 sh \times 10^{-3}$
	* For the requirements for barges carrying liquid cargoes in bulk see Pt 4, Ch 10 Single Hull Oil Tankers
Note The scantlings derived from above need not exceed the scantling requirements of Pt 4, Ch 1 General Cargo Ships or Pt 4, Ch 10 Single Hull Oil Tankers, whichever is applicable.	

4.5 Primary supporting structure

4.5.1 Primary supporting members are to comply with the requirements of Table 5.4.3 Primary supporting structure.

Table 5.4.3 Primary supporting structure

Position of member	Modulus, in cm ³
Bottom transverse	* $Z = 11,0l_e^2 Sh$
Side transverse	* $Z = 8,0l_e^2 Sh$ (may be reduced by 5 per cent for vessels classed '100A1 extended protected water service')
Deck transverse	* $Z = 5,5l_e^2 Sh$
Bottom girder	* $Z = 9,5l_e^2 Sh$
Deck longitudinal girder	* $Z = 5,0l_e^2 Sh$
	* For the requirements for barges carrying liquid cargoes in bulk see Pt 4, Ch 10 Single Hull Oil Tankers
Note The scantlings derived from above need not exceed the scantling requirements of Pt 4, Ch 1 General Cargo Ships or Pt 4, Ch 10 Single Hull Oil Tankers, whichever is applicable	

■ **Section 5**
Strengthening of bottom forward

5.1 Application

5.1.1 The requirements for strengthening of bottom forward detailed in Pt 3, Ch 5 Fore End Structure do not apply to barges or pontoons less than 50 m in length.

■ **Section 6**
Bottom strengthening for loading and unloading aground

6.1 Application

6.1.1 For barges or pontoons intended to load or unload while aground, see Pt 3, Ch 9, 7 Bottom strengthening for loading and unloading aground.

■ **Section 7**
Watertight bulkheads

7.1 Collision bulkheads

7.1.1 Barges and pontoons are to have a collision bulkhead extending intact to the strength/weather deck and, in general, this is to be positioned as detailed in *Table 5.7.1 Collision bulkhead position*.

Table 5.7.1 Collision bulkhead position

Length <i>L</i> , in metres	Distance of collision bulkhead aft of fore end of <i>L</i> , in metres, <i>see Figure 5.1.1 Definition of Rule length</i>	
	Minimum	Maximum
≤ 150	0,05 <i>L</i>	0,05 <i>L</i> + 4,5
> 150	The lesser of: 0,05 <i>L</i> or 10	0,08 <i>L</i>

■ **Section 8**
Void spaces

8.1 Void spaces on unmanned pontoons not fitted with auxiliary machinery

8.1.1 Drainage arrangements and air pipes are to be provided in accordance with *Pt 5, Ch 13, 10 Drainage arrangements for ships not fitted with propelling machinery* and *Pt 5, Ch 13, 12.4 Air pipes 12.4.4* respectively.

8.1.2 Deck openings to allow drainage in accordance with *Pt 5, Ch 13, 10.1 Pumps 10.1.3* are to be as small as practicable and closed by watertight gasketed covers of steel or equivalent material.

Section

- 1 **General**
- 2 **Protection**
- 3 **Longitudinal strength**
- 4 **Deck structure**
- 5 **Shell envelope plating**
- 6 **Shell envelope framing**
- 7 **Watertight bulkheads**
- 8 **Stern ramp, and cruiser and transom sterns**
- 9 **Strengthening of bottom forward**

■ *Section 1*
General

1.1 Application

- 1.1.1 This Chapter applies to sea-going steel trawlers, stern trawlers and fishing vessels.
- 1.1.2 For the purpose of this Chapter, a fishing vessel is a ship used for fishing operations, but not equipped for trawling.
- 1.1.3 The scantlings and arrangements are to be as required by *Pt 4, Ch 1 General Cargo Ships* except as otherwise specified in this Chapter. Consideration will be given to proposals for modified scantlings on vessels where *L* is less than 24 m.

1.2 Assignment of load lines

- 1.2.1 The *International Convention on Load Lines, 1966* does not apply to trawlers and fishing vessels, but certain National Authorities may request the assignment of load lines for ships registered in their countries.
- 1.2.2 The Rules affecting the protection of openings and protection of crew, and particularly those contained in *Pt 3, Ch 11 Closing Arrangements for Shell, Deck and Bulkheads* and *Pt 3, Ch 12 Ventilators, Air Pipes and Discharges*, may be modified to take account of National Regulations or practicabilities related to fishing operations.

1.3 Class notations

- 1.3.1 In general, ships complying with the requirements of this Chapter will be eligible for one of the following classes:
 - (a) **100A1 trawler**. This class will be assigned to side fishing trawlers.
 - (b) **100A1 stern trawler**. This class will be assigned to stern fishing trawlers.
 - (c) **100A1 fishing vessel**. This class will be assigned to fishing vessels, see *Pt 4, Ch 6, 1.1 Application 1.1.2*.
- 1.3.2 The Regulations for classification and the assignment of class notations are given in *Pt 1, Ch 2 Classification Regulations* to which reference should be made.

1.4 Information required

- 1.4.1 In addition to the information required by *Pt 3, Ch 1, 5 Information required*, the position and arrangement of trawl gear and deck machinery and location of insulated compartments are to be indicated.

1.5 Symbols and definitions

1.5.1 The Rule length, L , is the distance, in metres, on the classification waterline from the fore side of the stem to the after side of the rudder post, or to the centre of the rudder stock if there is no rudder post. L is to be not less than 96 per cent, and need not be greater than 97 per cent, of the extreme length on the classification waterline.

1.5.2 Breadth B , is the greatest moulded breadth, in metres.

1.5.3 Depth D , is measured, in metres, at the middle of the length, L from the base line to top of the deck beam at side on the uppermost continuous deck.

1.5.4 The classification waterline in single deck ships is the waterline taken perpendicular to the plane of the transverse bulkheads located at $0,85D$ from the base line amidships, or at the maximum operational draught amidships, whichever is the greater. In two-deck ships, it is the waterline located at the maximum operational draught, but if this is unknown, it may be taken at 50 mm below the lower deck. If a load line is required by a National Authority, the classification waterline is the summer load waterline.

1.5.5 Keel line is the line parallel to the slope of the keel intersecting the top of the keel at amidships, or the line of intersection of the inside of shell plating with the keel where a bar keel is fitted.

1.5.6 Base line is a line parallel to the classification waterline and intersecting the keel line at amidships.

1.5.7 Draught T , is the distance in metres, between the classification waterline and the base line amidships.

1.5.8 The block coefficient C_b is to be taken at the classification waterline.

1.5.9 The following symbols are also applicable to this Chapter:

k = material factor, see Pt 4, Ch 1, 1.5 Symbols and definitions

l_e = effective length of stiffening member, in metres, see Pt 3, Ch 3, 3 Structural idealisation

s = spacing of stiffeners, in mm

$s_b = 470 + \frac{L}{0,6}$ with minimum limitation at ends as defined in Pt 3, Ch 5, Table 5.3.1 Shell plating forward for fore end structure and Pt 3, Ch 6 Aft End Structure, Table 6.3.1 Shell plating aft for aft end structure

$s_1 = s$, but not less than s_b

t = thickness of plating, in mm

Z = section modulus of stiffening member, in cm^3 , see Pt 3, Ch 3, 3 Structural idealisation

■ Section 2 Protection

2.1 Protection of steelwork

2.1.1 Where wood sheathing is fitted, the material is to be of good quality, well seasoned and free from sapwood, and the thickness is to be not less than 65 mm. The plank widths should not normally exceed 150 mm. Thwartship planks are to be laid at the ends of deckhouses and at break of deck. Fastenings are to be sunk below the surface of the planking and covered with turned dowels, and the whole to be thoroughly bedded in a suitable composition. All weather decks are to be caulked and payed.

2.1.2 Where gutter waterways are fitted, the bar forming the inner edge of the waterway is to be not less than 7,5 mm thick.

2.1.3 Welded studs are to be not less than 9,5 mm diameter, and are to be coated with suitable composition before the planking is laid. Bolts used instead of studs may be 12,5 mm diameter galvanised. If the steel deck is penetrated for bolts, the deck is to be hose tested in accordance with Pt 3, Ch 8 Superstructures, Deckhouses and Bulwarks.

2.2 Protection of cargo

2.2.1 When a fuel oil bunker or double bottom carrying fuel oil, or a lubricating oil tank, is adjacent to a fish hold, the relevant requirements of *Pt 4, Ch 3, 4 Panting and strengthening of bottom forward* are to be complied with.

2.2.2 Compartments used for the processing of fish, or for temporary storage during or while awaiting processing, need not comply with the requirements of *Pt 4, Ch 6, 2.2 Protection of cargo 2.2.1*, but the construction of the bulkheads, decks and insulation, if any, should be such as to minimise the risk of oil leakage.

■ *Section 3*
Longitudinal strength

3.1 General

3.1.1 The longitudinal strength standard is to comply with the relevant requirements of *Pt 3, Ch 4 Longitudinal Strength*.

3.1.2 The requirements of *Pt 3, Ch 4, 8.3 Loading instrument* regarding loading instruments are not applicable to trawlers and fishing vessels.

■ *Section 4*
Deck structure

4.1 Deck plating

4.1.1 The thickness of deck plating is to be not less than that required by *Pt 4, Ch 1, 4 Deck structure*. Under the trawl winch, windlass, mast, centre and side bollards and gallows, the plating thickness is to be not less than:

$$t = (0,04L + 7,5) \text{ mm}$$

where L is to be taken not less than 30 m.

4.1.2 When a raised deck is fitted, adequate scarfing is to be arranged at the step.

4.2 Factory deck beams

4.2.1 The section modulus of the beams of factory decks under fish handling spaces is to be not less than that required by *Table 1.4.5 Strength/weather, cargo and accommodation deck beams* in *Pt 4, Ch 1 General Cargo Ships*, with h_2 equal to 2 m, but extra strengthening may be required in way of heavy items of machinery or equipment.

■ *Section 5*
Shell envelope plating

5.1 Shell plating

5.1.1 The thickness of shell plating is to be not less than that required by *Pt 4, Ch 1, 5 Shell envelope plating* but in no case is it to be less than the following:

$$\text{For } L \leq 70\text{m} \quad t = (5,5 + 0,033L) \sqrt{\frac{ks_1}{s_b}} \text{ mm}$$

$$\text{For } L > 70\text{m} \quad t = (6,5 + 0,033L) \sqrt{\frac{ks_1}{s_b}} \text{ mm}$$

-
- 5.1.2 For single deck side trawlers the thickness derived from the formulae in *Pt 4, Ch 6, 5.1 Shell plating 5.1.1* is to be increased by 10 per cent.
- 5.1.3 When nets or control wires are in contact with the ship's side, such as below the gallows in a side trawler, the side shell plating is to be increased by 40 per cent.
- 5.1.4 Where a bar keel is fitted, the breadth of the garboard strake is to be not less than 760 mm, and the thickness is to be 10 per cent greater than the bottom shell.
- 5.1.5 The thickness of the bottom shell plating is to be increased by 10 per cent where intercostal girders are not fitted.
- 5.1.6 For increase to sheerstrake at the break of a raised deck, see *Pt 4, Ch 1, 5 Shell envelope plating*.
- 5.1.7 Cope irons are to be fitted under gallows or any other area where excessive wear could occur.
-

■ Section 6 Shell envelope framing

6.1 Transverse side framing

- 6.1.1 The section modulus of the side frames of single deck trawlers and fishing vessels need not be greater than 80 per cent of the modulus required by *Pt 4, Ch 1, 6 Shell envelope framing*, but in no case is the depth of the frame to be less than 60 mm. Where not specified the draught is to be taken as not less than $0,85D$.
- 6.1.2 For two deck trawlers and two deck fishing vessels and all vessels requiring a load line, the requirements of *Pt 4, Ch 1, 6 Shell envelope framing* are to be complied with.
- 6.1.3 The section modulus of frames in the fore peak is to be the greater of the following:
- (a) 10 per cent greater than that required by *Pt 3, Ch 5, 4 Shell envelope framing*.
- (b)
- $$Z = (45D - 212) \text{ cm}^3.$$
- 6.1.4 The section modulus of frames in the aft end region is to be not less than that required by *Pt 3, Ch 6, 3 Shell envelope plating*.
- 6.1.5 Where frames are stopped at watertight flats they are to be bracketed.
-

■ Section 7 Watertight bulkheads

7.1 Collision bulkheads

- 7.1.1 Consideration will be given to proposals for the collision bulkhead to be positioned further aft than $0,08L$ from the fore end of the classification waterline, provided that bow damage will not result in excessive trim forward.
-

■ Section 8 Stern ramp, and cruiser and transom sterns

8.1 Stern ramp

- 8.1.1 The thickness of plating of the stern ramp is to be not less than:

$$t = 0,025s \text{ mm or } 10 \text{ mm, whichever is the greater.}$$

- 8.1.2 The section modulus of stiffeners is to be not less than:
-

$$Z = 0,019s / e^2 \text{ cm}^3$$

8.2 Cruiser and transom sterns

8.2.1 Cruiser and transom sterns are to have frames of the size required for peaks, and are to be additionally stiffened by web frames when required. The depth of plate floors is to be not less than that given in *Pt 4, Ch 1, 7 Single bottom structure*, and the floors are to be associated with a suitable system of girders.

■ Section 9 Strengthening of bottom forward

9.1 General

9.1.1 The requirements of *Pt 3, Ch 5, 1 General* are to be applied except when the forward draught contemplated for any sea-going condition is equal to or greater than $0,03L$ in which case the bottom shell plating in the region to be strengthened may be taken as:

$$t = 0,00818 s f L^{1/4} k^{1/2}$$

where the symbols are as defined in *Table 5.1.1 Additional strengthening of bottom forward* in *Pt 4, Ch 5 Barges and Pontoons*.

This thickness derivation may be adopted for both longitudinal and transverse framing.

Section

- 1 **General**
- 2 **Materials and protection**
- 3 **Longitudinal strength**
- 4 **Deck structure**
- 5 **Shell envelope plating**
- 6 **Shell envelope framing**
- 7 **Topside tank structure**
- 8 **Double bottom structure**
- 9 **Hopper side tank structure**
- 10 **Bulkheads**
- 11 **Direct calculation**
- 12 **Steel hatch covers**
- 13 **Hatch coamings**
- 14 **Forecastles**

■ *Section 1*
General

1.1 General

1.1.1 This Chapter applies to sea-going self propelled ships, constructed generally with single deck, double bottom, hopper side tanks and topside tanks and with single or double side skin construction in the cargo length area, and intended primarily for the carriage of bulk dry cargoes.

1.1.2 A 'bulk carrier of single side skin construction' is defined as a bulk carrier where one or more cargo holds are bound by the side shell only, or by two watertight boundaries, one of which is the side shell, which are less than 1000 mm apart.

1.1.3 The term 'bulk carrier of double side skin construction' is defined as a bulk carrier where all cargo holds are bound by two watertight boundaries, one of which is the side shell, which are greater than or equal to 1000 mm apart at any location within the hold length.

1.1.4 The ShipRight Procedures for the hull construction of ships are detailed in *Pt 3, Ch 16 ShipRight Procedures for the Design, Construction and Lifetime Care of Ships* and the classification notations and descriptive notes associated with these procedures are given in *Pt 1, Ch 2, 3 Surveys - General*.

1.1.5 The attention of Owners, Masters and Cargo Shippers is drawn to the IMO Code of Safe Practice for Solid Bulk Cargoes when shipping these cargoes. Attention is also drawn to any relevant statutory requirements of the National Authority of the country in which the ship is to be registered, and any special requirements of the Port Authorities at the ports of loading and discharge.

1.1.6 The Regulations for classification and the assignment of class notations are given in *Pt 1, Ch 2 Classification Regulations* to which reference should be made.

1.2 Application

1.2.1 Single skin and double skin bulk carriers with length, L , greater than or equal to 90 m with structural configuration as shown in *Figure 7.1.1 CSR-BC Applicability* are defined as ‘CSR Bulk Carriers’ and are to comply with *Pt 4, Ch 7, 1.4 Class notation for CSR bulk carriers*.

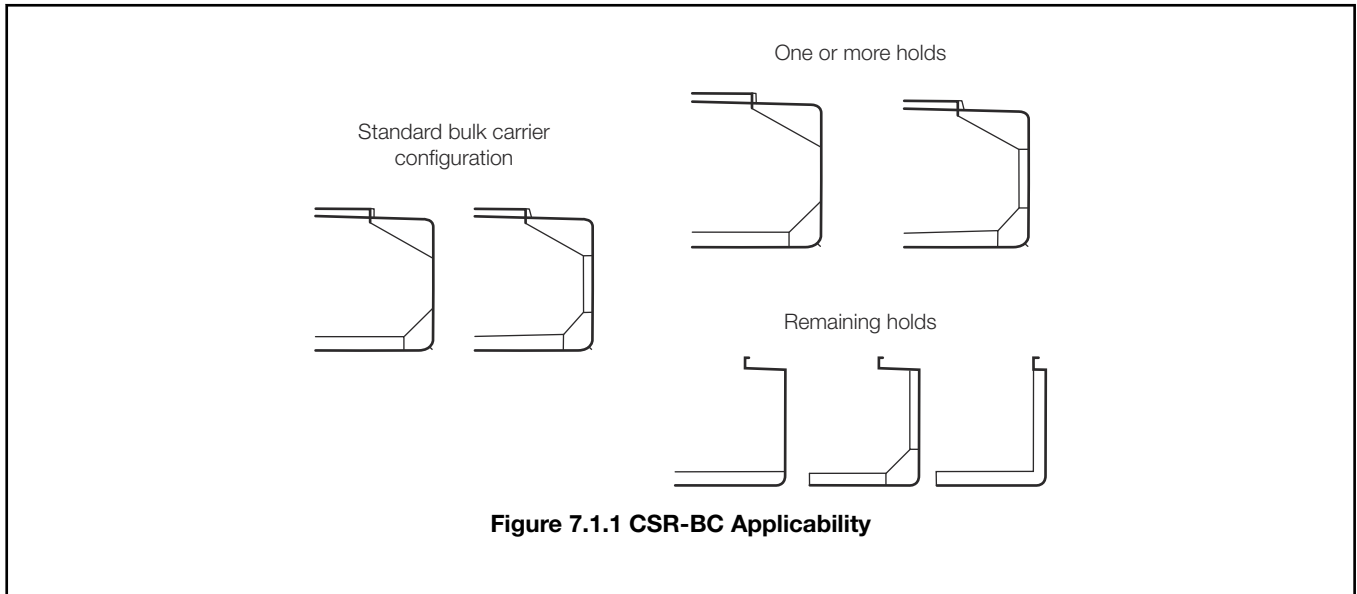

Figure 7.1.1 CSR-BC Applicability

1.2.2 Single skin and double skin bulk carriers other than those described in *Pt 4, Ch 7, 1.2 Application 1.2.1* are defined as ‘Non- CSR Bulk Carriers’ and are to comply with *Pt 4, Ch 7, 1.5 Class notation for non-CSR bulk carriers*.

1.3 General class notations

1.3.1 Class notations applicable to CSR bulk carriers are defined as follows:

- **CSR**

Identifies the bulk carrier as being compliant with the *IACS Common Structural Rules for Bulk Carriers and Oil Tankers (CSR)*;

- **ESP**

Identifies the bulk carrier as being subject to an Enhanced Survey Programme as detailed in *Pt 1, Ch 3, 3 Intermediate Surveys - Hull and machinery requirements* and *Pt 1, Ch 3, 6 Special Survey - Bulk carriers - Hull requirements*, see also *Pt 1, Ch 2, 2.3 Class notations (hull) 2.3.12*.

1.3.2 Class notations applicable to non-CSR bulk carriers are defined as follows:

- **Strengthened for heavy cargoes**

For bulk carriers with scantlings complying with *Pt 4, Ch 7, 8.2 Carriage of heavy cargoes*;

- **ESP**

Identifies the bulk carrier as being subject to an Enhanced Survey Programme as detailed in *Pt 1, Ch 3, 3 Intermediate Surveys - Hull and machinery requirements* and *Pt 1, Ch 3, 6 Special Survey - Bulk carriers - Hull requirements*, see also *Pt 1, Ch 2, 2.3 Class notations (hull) 2.3.12*;

- **ESN**

Identifies the bulk carrier as having been assessed for enhanced survivability with respect to flooding. Scantlings and arrangements are to comply with *Pt 4, Ch 7, 3.1 General 3.1.2*, *Pt 4, Ch 7, 8.8 Allowable hold loading in the flooded condition* and *Pt 4, Ch 7, 10.4 Vertically corrugated transverse watertight bulkheads – Application and definitions*.

1.4 Class notation for CSR bulk carriers

1.4.1 In general, CSR bulk carriers less than 150 m in length are to comply with the requirements of *Pt 4, Ch 7, 1.6 Information required for CSR bulk carriers, Pt 3, Ch 2 Materials* and the *IACS Common Structural Rules (CSR)* and will be eligible for one of the following mandatory class notations:

- (a) **100A1 bulk carrier, CSR, any holds may be empty, ESP.** This class notation is normally assigned to a ship designed to carry dry bulk cargoes of cargo density 1,0 tonne/m³ and above, with an approved arrangement of loaded holds such that any hold may be empty at the full loaded draught.
- (b) **100A1 bulk carrier, CSR, hold, nos. 1, 2 ... may be empty, ESP.** This class notation is normally assigned to a ship designed to carry dry bulk cargoes of cargo density 1,0 tonne/m³ and above with specified holds empty at maximum draught.
- (c) **100A1 bulk carrier, CSR, ESP.** This class notation will be assigned to a ship designed to carry dry bulk cargoes of cargo density less than 1,0 tonne/m³.

1.4.2 In general, CSR bulk carriers equal to or greater than 150 m in length are to comply with the requirements of *Pt 4, Ch 7, 1.6 Information required for CSR bulk carriers, Pt 3, Ch 2 Materials* and the *IACS Common Structural Rules (CSR)* and will be eligible for one of the following mandatory class notations:

- (a) **100A1 bulk carrier, CSR, BC-A, hold, nos. 1, 2 ... may be empty, GRAB [X] ESP.** This class will be assigned for bulk carriers designed to carry dry bulk cargoes of cargo density 1,0 tonne/m³ and above with specified holds empty at maximum draught.
- (b) **100A1 bulk carrier, CSR, BC-B, GRAB [X], ESP.** This class will be assigned for bulk carriers designed to carry dry bulk cargoes of cargo density 1,0 tonne/m³ and above with all cargo holds loaded.
- (c) **100A1 bulk carrier, CSR, BC-C, ESP.** This class will be assigned for bulk carriers designed to carry dry bulk cargoes of cargo density less than 1,0 tonne/m³ with all cargo holds loaded.

1.4.3 The following additional notations and annotations are to be provided giving further detailed description of limitations to be observed during operation as a consequence of the design loading condition applied during the design.

- **Notations:**

- (a) **(maximum cargo density (in tonnes/m³))** For notations **BC-A** and **BC-B** if the maximum cargo density is less than 3,0 tonnes/m³,

(no MP) For all notations when the vessel has not been designed for loading and unloading in multiple ports in accordance with the conditions specified in *IACS Common Structural Rules (CSR)*, Pt 1, Ch 4, Sec 8,4.2.2:

GRAB [X] where the net thickness of inner bottom, lower strake of hopper tank sloping plate and transverse lower stool plating comply with *IACS Common Structural Rules (CSR)*, Pt 2, Ch 1, 6 for **BC-A** and **BC-B**, see *IACS Common Structural Rules (CSR)*, Pt 1, Ch 1, Sec 1,3.2.1;

- **Annotations:**

(allowed combination of specified empty holds). For notation **BC-A**.

1.4.4 The 'Construction Monitoring' (CM) procedures detailed in the *ShipRight Procedures Manual*, published by LR, are mandatory for bulk carriers greater than 190 m in length.

1.4.5 Optional notations indicating compliance with specific requirements of *Pt 4, Ch 7, 3 Longitudinal strength* to *Pt 4, Ch 7, 14 Forecastles* on a voluntary basis may also be assigned.

1.5 Class notation for non-CSR bulk carriers

1.5.1 In general, non-CSR Bulk Carriers are to comply with the requirements of *Pt 4, Ch 7, 1.5 Class notation for non-CSR bulk carriers 1.5.2* to *Pt 4, Ch 7, 1.5 Class notation for non-CSR bulk carriers 1.5.7* and will be eligible for one of the following mandatory class notations:

- (a) **100A1 bulk carrier, ESP.**
- (b) **100A1 bulk carrier, strengthened for heavy cargoes, ESP.** This class notation will be assigned to a ship when the double bottom structure has been specially strengthened in accordance with the requirements of *Table 7.8.1 Strengthening for heavy cargo requirements*.
- (c) **100A1 bulk carrier, strengthened for heavy cargoes, hold, nos. 1, 2 ... may be empty, ESP.** This class notation is normally assigned to a ship which has been specially strengthened for heavy cargoes, see *Pt 4, Ch 7, 1.5 Class notation for*

non-CSR bulk carriers 1.5.1, so as to enable the ship to be fully loaded with an approved arrangement of empty holds, see also *Pt 4, Ch 7, 1.5 Class notation for non-CSR bulk carriers 1.5.7* and *Pt 4, Ch 7, 1.4 Class notation for CSR bulk carriers 1.4.3*.

- (d) **100A1 bulk carrier, strengthened for heavy cargoes, any holds may be empty, ESP.** This class notation is normally assigned to a ship which has been specially strengthened for heavy and ore cargoes, with an approved arrangement of loaded holds such that any hold may be empty at the full loaded draught.

1.5.2 Plans and information are to be submitted in accordance with *Pt 4, Ch 7, 1.7 Information required for non-CSR bulk carriers*.

1.5.3 Requirements are also given for special strengthening for heavy cargoes, see *Pt 4, Ch 7, 8.2 Carriage of heavy cargoes*.

1.5.4 The scantlings and arrangements of the cargo region are to be as specified in this Chapter in *Pt 4, Ch 7, 2 Materials and protection to Pt 4, Ch 7, 14 Forecastles*. The requirements are intended to cover the midship region, but also apply, with suitable modification, to the taper regions forward and aft in way of cargo spaces.

1.5.5 The 'Structural Design Assessment' (**SDA**), 'Fatigue Design Assessment' (**FDA**) and 'Construction Monitoring' (**CM**) procedures detailed in the *ShipRight Procedures Manual*, published by LR, are mandatory for non-CSR bulk carriers greater than 190 m in length and for other non-CSR bulk carriers of abnormal hull form, or of unusual structural configuration or complexity see *Pt 4, Ch 7, 1.1 General 1.1.5* and *Pt 4, Ch 7, 11 Direct calculation*.

1.5.6 Where the class notation referred to in *Pt 4, Ch 7, 1.5 Class notation for non-CSR bulk carriers 1.5.1* is assigned such that any hold may be empty at the full draught the following items are to be considered and the corresponding requirements complied with:

- (a) Longitudinal strength calculations are to be carried out for all the operational fully loaded, non-homogeneous, part loaded, heavy cargo conditions, and these conditions included in the approved Loading Manual, see *Pt 4, Ch 7, 3 Longitudinal strength*. Envelopes of the still water bending moments and the shear forces covering these conditions are also to be submitted.
- (b) The double bottom structure in each hold is to satisfy the requirements of *Pt 4, Ch 7, 8.4 Ships to be classed '100A1 bulk carrier, strengthened for heavy cargoes, any hold may be empty, ESP'*.
- (c) The arrangement and scantlings of cross-deck structure between the upper deck cargo hatchways, see *Pt 4, Ch 7, 4.1 General 4.1.2*.
- (d) Transverse bulkheads in holds, see *Pt 4, Ch 7, 10.1 General 10.1.4*.
- (e) For main cargo hatchway openings the requirements of *Pt 4, Ch 7, 4.3 Main cargo hatchway openings 4.3.1* are to be complied with.

1.5.7 Where appropriate, other cargoes or particular loading arrangements will be included in the class notation. When the class notation referred to in *Pt 4, Ch 7, 1.5 Class notation for non-CSR bulk carriers 1.5.1* is to be assigned for other combinations of empty and loaded holds, for example where it is the intention to load fully any two adjoining holds with adjacent holds empty in sea-going or short voyage conditions, the longitudinal and local strength aspects will be specially considered, see also *Pt 4, Ch 7, 4.1 General 4.1.2*. In addition, permissible weights of cargo in each hold or pair of adjacent holds, plotted against ship's draught likely to be incurred, are to be included in the ship's approved Loading Manual.

1.5.8 The scantlings of structural items may be determined by direct calculation.

1.5.9 The additional requirements for bulk carriers for the alternate carriage of oil cargo and dry bulk cargo are given in *Pt 4, Ch 9, 11 Ships for alternate carriage of oil cargo and dry bulk cargo*. When complying with the requirements of this Chapter, such ships may be excluded from all requirements and notations pertaining to vessels with length, *L*, greater than or equal to 150 m. The requirements of *Pt 4, Ch 7, 1.5 Class notation for non-CSR bulk carriers 1.5.5* are however to be complied with.

1.6 Information required for CSR bulk carriers

1.6.1 In addition to the plans and documents required by the CSR the following are to be submitted:

- Ice strengthening.
- Freeboard plan or equivalent showing freeboards and items relative to the conditions of assignment.
- In addition the supporting calculations given in *Pt 3, Ch 1, 5.2 Plans and supporting calculations 5.2.3* are to be submitted.

1.7 Information required for non-CSR bulk carriers

1.7.1 In addition to the information and plans required by *Pt 3, Ch 1, 5 Information required*, the following are to be submitted:

- Cargo loadings on decks, hatchways and inner bottom if these are to be in excess of Rule, see *Pt 3, Ch 3, 5 Design loading*.
- The maximum pressure head in service on tanks, also details of any double bottom tanks interconnected with hopper and topside tanks.
- Details of the proposed depths of any partial fillings where water ballast or liquid cargo is intended to be carried in the holds.
- Details of loading arrangements where combinations of empty and loaded holds are envisaged, and where it is the intention to load fully any two adjoining holds with adjacent holds empty in sea-going or short voyage conditions.

1.7.2 Additional information required for bulk carriers of length, L , 150 m or above:

- The bulk cargo density to be used in the design homogeneous loading condition at scantling draught with all holds, including hatchways, being 100 per cent full.
- The maximum bulk cargo density the ship is designed to carry.
- The maximum bulk cargo weight to be carried in each hold.
- Tables or curves indicating the change of cargo hold volume as a function of height above moulded baseline.

1.8 Symbols and definitions

1.8.1 The following symbols and definitions are applicable to this chapter unless otherwise stated: L , B , D , T as defined in *Pt 3, Ch 1, 6 Definitions*

k_L, k = higher tensile steel factor, see *Pt 3, Ch 2, 1 Materials of construction*

l = overall length of stiffening member, in metres, see *Pt 3, Ch 3, 3 Structural idealisation*

l_e = effective length of stiffening member, in metres, see *Pt 3, Ch 3, 3 Structural idealisation*

s = spacing of secondary stiffeners, in mm

t = thickness of plating, in mm

C = stowage rate, in $m^3/tonne$, as defined in *Pt 3, Ch 3, 5 Design loading*

I = inertia of stiffening member, in cm^4 , see *Pt 3, Ch 3, 3 Structural idealisation*

M_H = the actual cargo mass in a cargo hold corresponding to a homogeneously loaded condition at maximum draught

M_{Full} = the cargo mass in a cargo hold corresponding to cargo with virtual density (homogenous mass/hold cubic capacity, minimum $1,0 \text{ tonne}/m^3$) filled to the top of the hatch coaming. M_{Full} is in no case to be less than M_H

M_{HD} = the maximum cargo mass allowed to be carried in a cargo hold according to design Loading conditions with specified holds empty at maximum draught

$R = \sin \theta$

S = spacing, or mean spacing, of primary members, in metres

Z = section modulus of stiffening member, in cm^3 , see *Pt 3, Ch 3, 3 Structural idealisation*

ρ = relative density (specific gravity) of liquid carried in a tank, and is not to be taken less than 1,025

θ = roll angle, in degrees

$$\sin \theta = \left(0,45 + 0,1 \frac{L}{B} \right) \left(0,54 - \frac{L}{1270} \right)$$

■ Section 2 Materials and protection

2.1 Materials and grades of steel

2.1.1 Materials and grades of steel are to comply with the requirements of *Pt 3, Ch 2 Materials*.

2.2 Protection of steelwork

2.2.1 For the protection of steelwork, in addition to the requirements specified in *Pt 4, Ch 1, 2 Materials and protection* and *Pt 3, Ch 2, 3 Corrosion protection* the requirements of *Pt 4, Ch 7, 2.2 Protection of steelwork 2.2.2* are to be complied with.

2.2.2 All internal and external surfaces of hatch coamings and hatch covers, and all internal surfaces of the cargo holds, except where excluded below, are to have an efficient protective coating (epoxy coating or equivalent) applied in accordance with the manufacturer's recommendations. In the selection of coating, due consideration is to be given to the intended cargo conditions in service. Areas which may remain uncoated are:

- (a) The inner bottom plating.
- (b) The hopper tank sloping plating between the intersection with the inner bottom plating and a line approximately 300 mm below the toe of the side shell frame end brackets.

2.2.3 For the notation '**strengthened for regular discharge by heavy grabs**', see *Pt 3, Ch 9, 7 Bottom strengthening for loading and unloading aground*.

■ Section 3 Longitudinal strength

3.1 General

3.1.1 Longitudinal strength calculations are to be made in accordance with the requirements given in *Pt 3, Ch 4 Longitudinal Strength* and *Pt 4, Ch 7, 1.5 Class notation for non-CSR bulk carriers 1.5.6* and *Pt 4, Ch 7, 1.5 Class notation for non-CSR bulk carriers 1.5.7* where appropriate.

3.1.2 Longitudinal strength calculations for the flooded conditions defined in *Pt 4, Ch 7, 3.2 Hull vertical bending stresses for flooded conditions* to *Pt 4, Ch 7, 3.4 Flooded conditions* are to be applied for bulk carriers which satisfy all of the following criteria:

- Single skin construction, or double skin construction where any part of the longitudinal bulkhead is located within B/5 or 11,5 m, whichever is less, inboard from the ship's side at right angles to the centreline at the assigned summer load line.
- Length, *L*, of 150 m or above.
- Intended for the carriage of cargoes having bulk densities of 1,0 tonne/m³ or above.

3.2 Hull vertical bending stresses for flooded conditions

3.2.1 The maximum hull vertical bending stresses in the flooded condition at deck, σ_{Df} , and keel, σ_{Bf} , for use in *Pt 3, Ch 4 Longitudinal Strength* are given by the following, using the appropriate combination of bending moments to give sagging and hogging stresses:

$$\sigma_{Df} = \frac{|M_{sf} + 0,8M_w| \times 10^{-3}}{Z_D} \text{ N/mm}^2 (\text{kgf/mm}^2)$$

$$\sigma_{Bf} = \frac{|M_{sf} + 0,8M_w| \times 10^{-3}}{Z_B} \text{ N/mm}^2 (\text{kgf/mm}^2)$$

where

M_{sf} = maximum still water bending moment in the flooded condition, in kN m (tonne-f m), at the section under consideration, see *Pt 4, Ch 7, 3.4 Flooded conditions*

where

M_w = design hull vertical wave bending moment, in kN m (tonne-f m), as defined in Pt 3, Ch 4, 5 *Hull bending strength* at the section under consideration

Z_D, Z_B = actual hull section moduli, in m³, at strength deck and keel respectively, at the section under consideration.

3.2.2 The maximum values of σ_{Df} and σ_{Bf} are to be used in Pt 3, Ch 4 *Longitudinal Strength*.

3.3 Shear stresses for flooded conditions

3.3.1 The shear stress, τ_{Af} , in the flooded condition to be used in Pt 3, Ch 4, 6 *Hull shear strength*, is to be taken as:

$$\tau_{Af} = 100Az \frac{|Q_{sf}| + |0,8Q_w|}{I \delta_i} \text{ N/mm}^2$$

$$\left(\tau_{Af} = 10,2Az \frac{|Q_{sf}| + |0,8Q_w|}{I \delta_i} \text{ kgf/mm}^2 \right)$$

where

Az = the first moment, in cm³, about the neutral axis, of the area of the effective longitudinal members between the vertical level under consideration and the vertical extremity of the effective longitudinal members, taken at the section under consideration

Q_{sf} = maximum hull still water shear force, in kN (tonne-f), in the flooded condition at the section under consideration

Q_w = design hull wave shear force, in kN (tonne-f), as defined in Pt 3, Ch 4, 6.3 *Design wave shear force* at the section under consideration

I = moment of inertia of the hull about the horizontal neutral axis, in cm⁴, at the longitudinal section under consideration

δ_i = defined in Pt 3, Ch 4, 6.5 *Permissible still water shear force*.

3.4 Flooded conditions

3.4.1 For the relevant loading conditions specified in Pt 3, Ch 4, 5.3 *Design still water bending moments* and Pt 3, Ch 4, 5.4 *Minimum hull section modulus*, each cargo hold is to be considered individually flooded up to the equilibrium waterline. The shear forces and still water bending moments are to be calculated for the most severe flooded conditions which will significantly load the ship's structure. Harbour conditions, docking conditions afloat, loading and unloading transitory conditions in port and loading conditions encountered during ballast water exchange need not be considered.

3.4.2 In calculating the weight of ingressed water into the cargo hold under consideration, the permeabilities and bulk densities given in Table 7.3.1 *Permeability and bulk density factors* are to be used.

Table 7.3.1 Permeability and bulk density factors

Hold condition	Permeability (see Note 1)	Bulk density (tonne/m ³)
Empty cargo space	0,95	-
Volume left in loaded cargo spaces above any cargo	0,95	-
Iron ore cargo	0,3 (see Note 2)	3,0

Cement	0,3 (see Note 2)	1,3
<p>Note 1. Bulk cargo permeability is defined as the ratio of the voids within the cargo mass to the volume occupied by the cargo.</p> <p>Note 2. More specific information relating to the bulk cargo may be used where available, but permeabilities are not to be less than those given above.</p> <p>Note 3. For packed cargo, the actual density of the cargo is to be used with a permeability of zero.</p>		

3.4.3 In calculating the strength of the ship's structure in the flooded condition it is to be assumed that the ship's structure will remain fully effective in resisting the applied loads.

■ *Section 4*
Deck structure

4.1 General

4.1.1 Longitudinal framing is, in general, to be adopted outside line of openings. The arrangement of structure between hatches is to be such as to ensure continuity of the main deck structure to resist athwartship forces, and transverse stiffening is to be arranged. For and aft knuckles in cross deck strip plating between hatches should be arranged close to longitudinal girders or supported by brackets.

4.1.2 In the case of large bulk carriers with narrow deck strips between hatchways, or where it is the intention to load any two adjoining holds with adjacent holds fully empty for a sea-going condition or for bulk carriers to be classed 'any hold may be empty', the cross deck scantlings will be specially considered.

4.1.3 The requirements of *Pt 4, Ch 1, 4 Deck structure* are to be applied, together with the requirements of this Section.

4.1.4 The *Shipright FDA Procedure, Structural Detail Design Guide (SDDG)*, indicates recommended structural design configurations in critical areas, for the deck structure outside the line of openings and between hatches.

4.2 Deck plating

4.2.1 Where the difference between the thickness of plating inside and outside the line of main hatches exceeds 12 mm, a transitional plate of thickness equivalent to the mean of the adjacent plate thicknesses is to be fitted. The plate thickness outside the line of hatches is to be continued inboard between hatches beyond the end of the hatch corner curvature, to ensure that the chamfered plating is clear of the corner tangent point.

4.3 Main cargo hatchway openings

4.3.1 The following requirements apply to bulk carriers with vertically corrugated transverse bulkheads in cargo holds having one or more of the following characteristics:

- (a) $B \geq 40$ m
- (b) $\frac{b}{w} \geq 2,2$

b = breadth of deck opening

w = width of cross deck strip

B = moulded breadth of ship

(c) A structural arrangement where the hatch side coaming and deck opening are arranged inboard of the topside tank.

(d) All bulk carriers to be classed 100A1 bulk carrier, strengthened for heavy cargoes, any hold may be empty, ESP.

4.3.2 The corners of main cargo hatchways in the strength deck are to be rounded with a radius not less than $\frac{1}{20}$ of the breadth of the opening, with a maximum radius of 1000 mm.

4.3.3 Insert plates are to be fitted at the corners having a thickness not less than 25 per cent greater than the adjacent deck thickness outside the line of openings, with a minimum increase of 5 mm, see also *Pt 4, Ch 7, 4.3 Main cargo hatchway openings 4.3.4*.

The corner inserts are to be extended transversely into the cross deck plating for a minimum distance equal to $0,075b$, where b , is the breadth of deck opening.

4.3.4 For the extreme corners of the end hatchways of the cargo region furthest from amidships the thickness of the corner insert plates is to be not less than 60 per cent greater than the adjacent deck thickness outside the line of openings.

4.4 Deck supporting structure

4.4.1 For the scantlings of deck longitudinals and transverses in way of topside tanks, see *Pt 4, Ch 7, 7.4 Shell and deck structure* and *Pt 4, Ch 7, 7.5 Primary supporting structure*, respectively.

■ Section 5 **Shell envelope plating**

5.1 General

5.1.1 Longitudinal framing is, in general, to be adopted at the bottom, but special consideration will be given to proposals for transverse framing in this region. The side shell may be longitudinally or transversely framed.

5.1.2 The requirements of *Pt 4, Ch 1, 5 Shell envelope plating* are to be applied together with the requirements of this Section.

5.2 Bottom shell

5.2.1 The thickness of the bottom shell plating below loaded holds may be required to be increased for local strength considerations.

5.3 Side shell

5.3.1 The thickness of the side shell plating may be required to be increased for shear forces to satisfy the requirements of *Pt 4, Ch 7, 3.2 Hull vertical bending stresses for flooded conditions 3.2.1*.

5.3.2 The thickness of the side shell plating located between the hopper and topside tanks of single skin bulk carriers is to be not less than:

$$t = \sqrt{L} \text{ mm}$$

■ Section 6 **Shell envelope framing**

6.1 Longitudinal stiffening

6.1.1 Side frames of all single skin bulk carriers with a hopper are to comply with *Pt 4, Ch 7, 6.2 Transverse stiffening* and *Pt 4, Ch 7, 6.3 Primary supporting structure*.

6.1.2 Side frames and end brackets of all double skin bulk carriers are to comply with *Pt 4, Ch 1, 6 Shell envelope framing*.

6.1.3 Side frames and end brackets of other structural configurations will be specially considered.

6.1.4 The end connections for the longitudinal stiffening are to satisfy the requirements of *Pt 3, Ch 10, 3 Secondary member end connections*, see also *Pt 4, Ch 7, 7.6 Structural details 7.6.1* and *Pt 4, Ch 7, 9.7 Structural details 9.7.1*.

6.1.5 The arrangements at the intersections of continuous secondary and primary members are to satisfy the requirements of *Pt 3, Ch 10, 5.2 Arrangements at intersections of continuous secondary and primary members* and *Pt 4, Ch 1, 6.2 Longitudinal stiffening*.

6.2 Transverse stiffening

6.2.1 The modulus and inertia of main and topside tank frames in the midship region are to comply with the requirements given in *Table 7.6.1 Shell framing*. Arrangements of main frames in holds in association with web frames are not recommended in view of the vulnerability to cargo handling damage. Where such web frames are proposed the arrangements and scantlings will be specially considered.

6.2.2 Main frames in the cargo and ballast holds are to have a web thickness not less than:

(a) In general:

$$t_{\min} = 7 + 0,03L \text{ mm,}$$

or 13 mm whichever is the lesser

(b) In the foremost hold:

$$t_{\min} = 1,15 (7 + 0,03L) \text{ mm,}$$

or 15 mm whichever is the lesser

where L is the Rule length, in metres.

6.2.3 The web depth to thickness ratio of the frames is not to be greater than:

$60\sqrt{k}$, for symmetric sections

$50\sqrt{k}$, for asymmetric sections

The breadth to thickness ratio of the flange outstand is not to be greater than:

$$10\sqrt{k}$$

6.2.4 The upper and lower end brackets of the main frames in the cargo and ballast holds are to satisfy the requirements of *Pt 4, Ch 7, 6.2 Transverse stiffening 6.2.5 to Pt 4, Ch 7, 6.2 Transverse stiffening 6.2.14* inclusive, based on the mild steel section modulus Z in cm^3 , derived from *Table 7.6.1 Shell framing*, or the equivalent mild steel section modulus for higher tensile steel frames.

6.2.5 The lengths of the arms of the brackets, measured as shown in *Figure 7.6.1 Diagrammatic arrangement of end brackets*, are not to be less than:

(a) Frame connection to hopper tank.

Athwartship arm:

$$\text{Dry cargo hold } l_a = 32,43\sqrt{Z} \text{ mm}$$

$$\text{Ballast hold } l_a = 32,43(\sqrt{Z} - 7,5) \text{ mm}$$

Vertical arm:

$$\text{Dry cargo hold } l_v = 27,6\sqrt{Z} \text{ mm}$$

$$\text{Ballast hold } l_v = 27,6(\sqrt{Z} - 9,0) \text{ mm}$$

(b) Frame connection to topside tank

Athwartship arm:

$$\text{Dry cargo hold } l_a = 30,0\sqrt{Z} \text{ mm}$$

$$\text{Ballast hold } l_a = 30,0(\sqrt{Z} - 9,0) \text{ mm}$$

Vertical arm:

$$\text{Dry cargo hold } l_v = 26,85\sqrt{Z} \text{ mm}$$

$$\text{Ballast hold } l_v = 26,85(\sqrt{Z} - 11,0) \text{ mm}$$

In no case are the bracket arm lengths to be taken less than $0,125H$, where H is as defined in *Table 7.6.1 Shell framing*.

Table 7.6.1 Shell framing

Location	Modulus, in cm ³	Inertia, in cm ⁴
(1) Main frames in dry cargo holds	$Z = 3,50skh_{T1} H^2 \times 10^{-3}$	$I = \frac{3,2}{k}HZ$
(2) Main frames in cargo holds used for water ballast	The greater of the following: (a) $Z = 1,15 \times$ modulus given in (1) (b) $Z = 6,7skh_4 H^2 \times 10^{-3}$	$I = \frac{3,2}{k}HZ$
(3) Transverse frames in topside wing tanks	The greater of the following: (a) $1,15 \times Z$ as given in location (1) of <i>Table 1.6.3 Shell framing (transverse)</i> (b) As required by <i>Pt 4, Ch 7, 7.3 Bulkhead stiffeners 7.3.1</i> for the sloped bulkhead stiffeners	$I = \frac{3,2}{k}HZ$
Symbols		
<p>D, T, s, k = as defined in <i>Pt 4, Ch 7, 1.7 Information required for non-CSR bulk carriers 1.7.1</i></p> <p>h_{T1} = head, in metres, at middle of <i>H</i></p> <p>= $C_W \left(1 - \frac{h_6}{D-T}\right) F_\lambda$ in metres, for frames where the mid-length of frame is above the summer load waterline,</p> <p>= $\left(1 - \frac{h_6}{D-T}\right)$ is not to be taken less than 0,7</p> <p>= $(h_6 + C_w \left(1 - \frac{h_6}{2T}\right)) F_\lambda$ in metres, where the mid-length of frame is below the summer load waterline</p> <p>h₄ = head, in metres, measured from the middle of <i>H</i> to the deck at side, or half the distance from the middle of <i>H</i> to the top of the overflow, whichever is greater.</p> <p>h₆ = vertical distance in metres, from the summer load waterline at draught <i>T</i> to the mid-length of <i>H</i></p> <p>C_w = a wave head, in metres</p> <p>= $7,71 \times 10^{-2} L e^{-0,0044L}$</p> <p>= where e = base of natural logarithms 2,7183</p> <p>F_λ = 1,0 for $L \leq 200$ m</p> <p>= $(1,0 + 0,0023 (L - 200))$ for $L > 200$ m</p> <p>H = length overall of frame, in metres, but is to be taken not less than 2,5 m</p>		

6.2.6 The section modulus of the frame and bracket or integral bracket, and associated shell plating at the location marked *Z_a* in *Figure 7.6.1 Diagrammatic arrangement of end brackets* is to be not less than 2,0*Z*.

In addition, the minimum depth of the frame and bracket or integral bracket at the location indicated in *Figure 7.6.1 Diagrammatic arrangement of end brackets* is to be not less than 1,5*d*.

6.2.7 The upper and lower integral or separate brackets are to have a web thickness not less than the as built web thickness of the side frame. In addition, the lower bracket thickness is to be not less than:

$$t = t_{\min} + 2 \text{ mm, where } t_{\min} \text{ is derived from Pt 4, Ch 7, 6.2 Transverse stiffening 6.2.2}$$

The toes of the brackets are to be designed to avoid notch effects by making the upper and lower toes concave or otherwise tapering them off, see also Pt 3, Ch 10, 5.1 Continuity and alignment 5.1.7.

6.2.8 Except as indicated in Pt 4, Ch 7, 6.2 Transverse stiffening 6.2.9, frames are to be fabricated symmetrical sections with integral upper and lower brackets.

The side frame face plate is to be curved (not knuckled) at the connection with the end brackets. The radius of curvature, r , is to be not less than:

$$r = \frac{0,4b_f^2}{t_f} \text{ mm}$$

where

b_f = breadth of the bracket face plate, in mm

t_f = thickness of the bracket face plate, in mm

The brackets are to be arranged with soft toes and the frame section face bar tapered symmetrically to the toes with a taper rate not exceeding 1 in 3. Where the free edge of the bracket is hollowed out, it is to be stiffened or increased in size to ensure that the section modulus of the bracket through the throat is not less than that of the required straight edged bracket.

6.2.9 In ships of length, L , less than 190 m, mild steel fabricated frames may be asymmetric and fitted with separate brackets. Brackets are to be arranged with soft toes. The free edges of the brackets are to be stiffened as follows:

(a) Where a flange is fitted, its breadth, b_f , is to be not less than:

$$b_f = 40 \left(1 + \frac{Z}{1000} \right) \text{ mm}$$

or 50 mm, whichever is the greater

The flange is to be tapered at the ends with a taper rate not exceeding 1 in 3.

(b) Where the edge is stiffened by a welded face flat, the cross-sectional area of the face flat is to be not less than:

(i) $0,009 b_f t \text{ cm}^2$ for offset edge stiffening

(ii) $0,014 b_f t \text{ cm}^2$ for symmetrically placed stiffening

where

t = web thickness of bracket, in mm

The face plate is to be tapered at the ends with a taper rate not exceeding 1 in 3.

6.2.10 For mild steel construction with separate brackets where the frames are lapped on to the bracket, the length of the overlap is to be adequate to provide for the required area of welding to achieve equivalent strength.

6.2.11 Double continuous welding is to be adopted for the connections of frames and brackets to side shell, hopper and topside tank plating and web to face plates. For this purpose, the following weld factors are to be adopted:

- 0,44 in Zone 'a' and
- 0,40 in Zone 'b', see Figure 7.6.1 Diagrammatic arrangement of end brackets.

Where the hull form is such that an effective fillet weld cannot be made, edge preparation of the web of the frame and bracket may be required, in order to ensure the required efficiency of the weld connection.

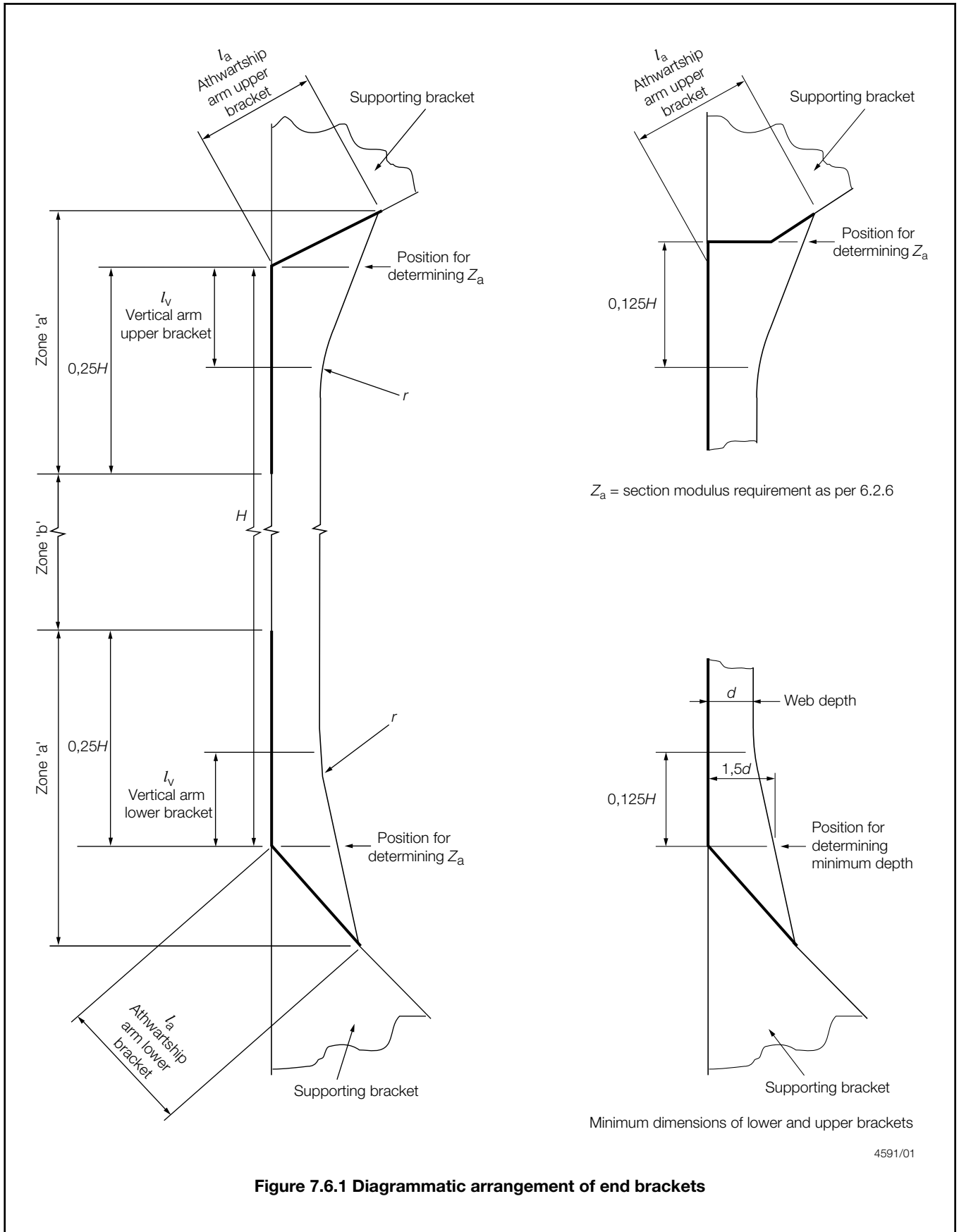

Figure 7.6.1 Diagrammatic arrangement of end brackets

4591/01

6.2.12 Continuity of the frames is to be maintained by supporting brackets, see *Figure 7.6.2 Supporting brackets in topside and hopper tanks*, in the topside and hopper tanks. The design of end connections and their supporting structure is to be such as to provide adequate resistance to rotation and displacement of the joint. For this purpose, in the hopper and topside tanks, the thickness of the supporting brackets (which must align with the hold main frame brackets) is to be not less than the following:

(a) Lower brackets (in hopper tank):

$$t = t_{\min} + 0,5 \text{ mm, where } t_{\min} \text{ is derived from Pt 4, Ch 7, 6.2 Transverse stiffening 6.2.2 or}$$

$$t = 9,0 \text{ mm}$$

whichever is the greater.

(b) Upper brackets (in topside tank):

$$t = t_{\min}, \text{ where } t_{\min} \text{ is derived from Pt 4, Ch 7, 6.2 Transverse stiffening 6.2.2 or}$$

$$t = 9,0 \text{ mm}$$

whichever is the greater.

The size and arrangement of stiffening of the supporting brackets will be specially considered. Where the toe of the hold frame bracket is situated on or in close proximity to the first longitudinal from the shell of the hopper or topside tank sloped bulkheads, the supporting brackets are to be extended to the next longitudinal. This extension is to be achieved by enlarging the supporting bracket or by fitting an intercostal flat bar stiffener the same depth as the longitudinal and connected to the webs of the longitudinals.

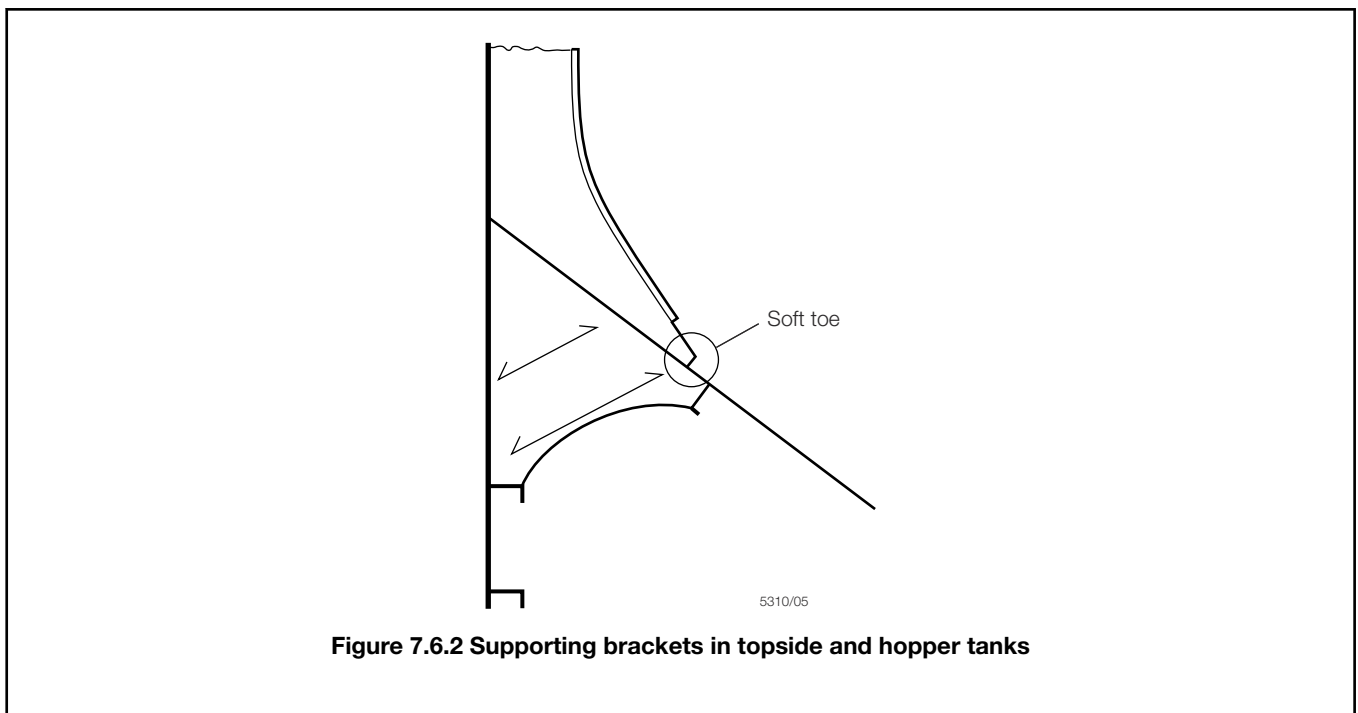

6.2.13 The requirements are to be maintained throughout the cargo hold region. However, in the forward and aft cargo holds where the shape becomes finer because of the ship form, increased requirements may be necessary and each case will be specially considered.

6.2.14 In way of the foremost hold, side frames of asymmetric section are to be effectively supported by intercostal brackets, see *Figure 7.6.3 Typical arrangement of intercostal brackets supporting asymmetric side shell frames in No. 1 hold*.

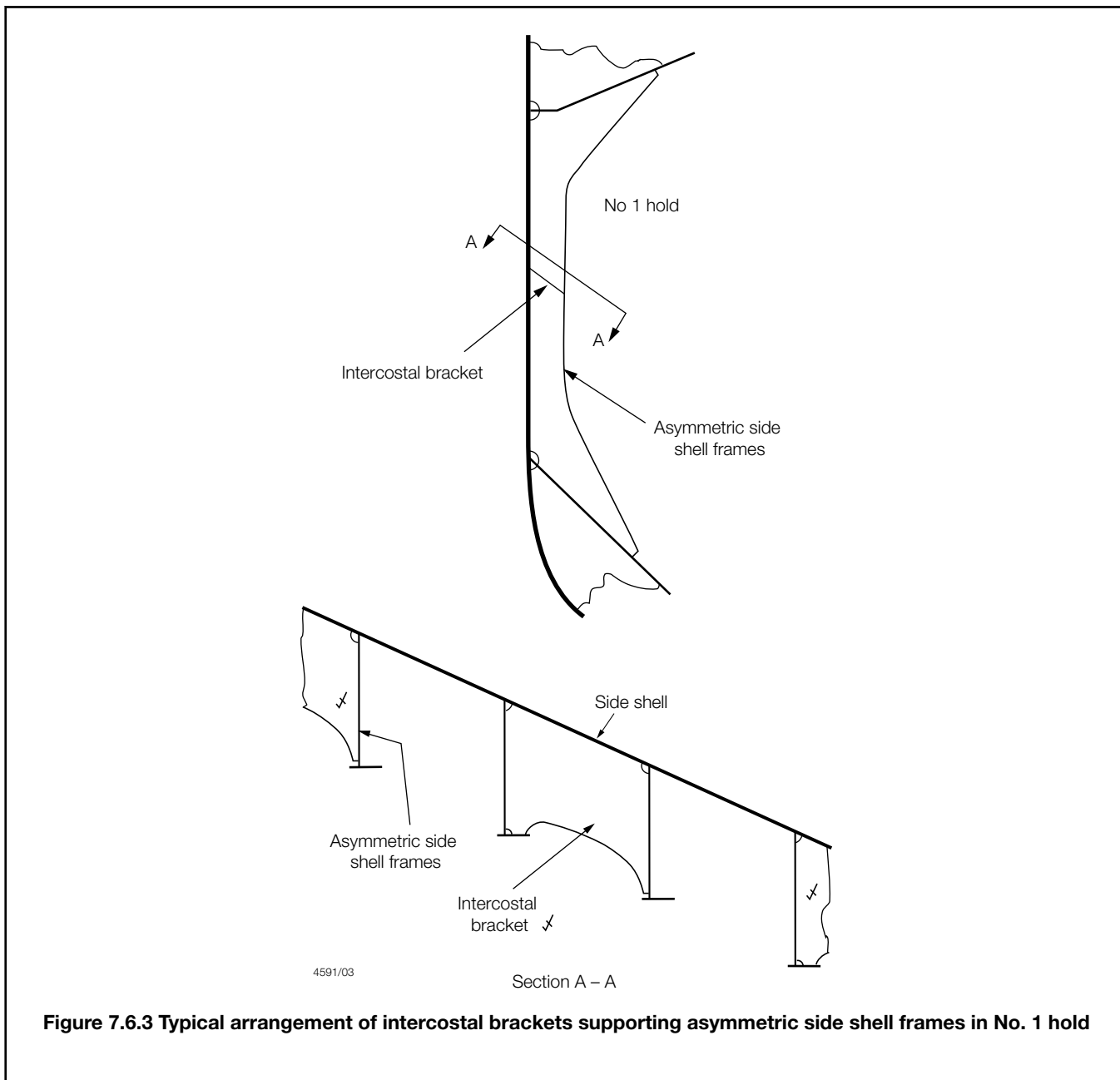

Figure 7.6.3 Typical arrangement of intercostal brackets supporting asymmetric side shell frames in No. 1 hold

6.2.15 The hold side shell frame adjacent to the collision bulkhead is to be suitably strengthened. As an alternative, at least two supporting structures are to be fitted which align with the forepeak stringers or flats, see Figure 7.6.4 Hold frame supporting structures at fore end of No. 1 cargo hold. The supporting structures are to have adequate cross-sectional shear resisting area at their connections to the hold frame.

6.2.16 Detail design guidelines for connection of side shell frames to hopper and topside tank plating are shown in the Shipright FDA Procedure, Structural Detail Design Guide (SDDG).

6.3 Primary supporting structure

6.3.1 For the requirements for primary supporting structure, see Pt 4, Ch 7, 7.5 Primary supporting structure and Pt 4, Ch 7, 9.6 Primary supporting structure.

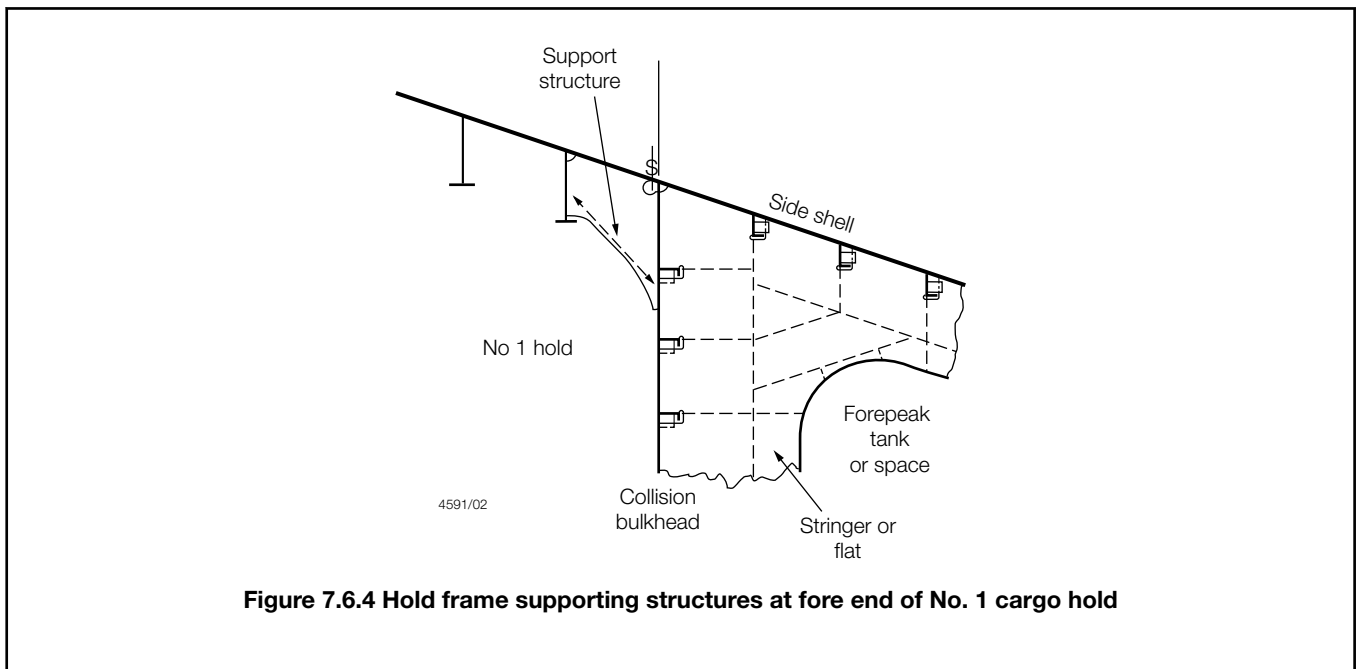

Figure 7.6.4 Hold frame supporting structures at fore end of No. 1 cargo hold

■ **Section 7**
Topside tank structure

7.1 General

7.1.1 Requirements are given in this Section for longitudinal or transverse framing in the topside tank, but, in general, the deck is to be longitudinally framed. The sloped bulkhead is to be of plane construction with the associated stiffening arranged inside or outside the tank.

7.1.2 The buckling requirements of *Pt 3, Ch 4, 7 Hull buckling strength* are also to be satisfied.

7.1.3 Recommended examples of structural design configurations around the transverse ring web of the topside tank can be seen in the *ShipRight FDA Procedure, Structural Detail Design Guide (SDDG)*.

7.2 Bulkhead plating

7.2.1 The thickness of the sloped bulkhead, tank end bulkhead, and diaphragm, if fitted, is to be the greater of the following:

- (a) For watertight bulkheads, the thickness, t , as derived from *Table 1.9.1 Watertight and deep tank bulkhead scantlings* in *Pt 4, Ch 1 General Cargo Ships* for a deep tank bulkhead using a head, h_4 , in metres, determined as follows:

$$h_4 = h_o \cos\theta + Rb_1 \text{ or}$$

= the greater of the distance from a point one-third of the height of the plate above its lower edge to the top of the tank, or half the distance to the top of the overflow

whichever is the greater, or

- (b) $t = 7.5 \text{ mm}$

In no case, however, is the thickness of the sloped bulkhead and diaphragm to be taken less than:

- (i) $t = 0,012s \text{ mm}$, or

$$t = 0,012s \sqrt{\frac{F_D}{k_D}} \text{ mm}$$

whichever is the greater

where

k_D = the higher tensile steel factor equal to k_L value for deck material

F_D = as defined in Pt 3, Ch 4, 5.7 Local reduction factors

R = as defined in Pt 4, Ch 7, 1.8 Symbols and definitions 1.8.1

h_o = the vertical distance, in metres, from a point one third of the height of the plate from the lower edge to the highest point of the tank excluding hatchway

b_1 = the larger horizontal distance, in metres, from the tank corner at top of tank either side to point of plate under consideration.

7.2.2 The thickness of the top strake of the sloped bulkhead, including the vertical plate attached to deck, may be required to be increased to form an effective girder below the deck. In general, this plate is to be not less in thickness than 60 per cent of the thickness of the deck plate outside the line of openings nor less than:

(a) $t = 0,018s$ mm, or

(b) $t = 0,018s \sqrt{\frac{F_D}{k_D}}$ mm

(a) whichever is the greater.

7.2.3 The thickness of the transverse wash bulkhead, where fitted, is to be not less than:

$t = 0,012s$ mm or 7,5 mm

= whichever is the greater.

7.3 Bulkhead stiffeners

7.3.1 The section modulus of longitudinal or transverse stiffeners on the sloped bulkhead or watertight diaphragms, if fitted, is to be not less than:

$$Z = 0,01skh_4 l_e^2 \text{ cm}^3$$

where

$$h_4 = h_o \cos\theta + Rb_1$$

= the greater of the distance, in metres, from the middle of the effective length to the top of the tank, or half the distance to the top of the overflow, or

= 1,5 m

= whichever is the greatest

R = as defined in Pt 4, Ch 7, 1.7 Information required for non-CSR bulk carriers 1.7.1

h_o = the vertical distance, in metres, from the mid-point of span of the stiffener to the highest point of the tank excluding hatchway

b_1 = the larger horizontal distance, in metres, from the tank corner at top of tank, either side to midpoint of span.

7.3.2 Where the bulkhead stiffening is fitted on the hold side of the sloped bulkhead, suitable arrangements are to be made to prevent tripping.

7.3.3 The scantlings of stiffeners on tank end bulkheads are to be not less than those given in Table 1.9.1 Watertight and deep tank bulkhead scantlings of Pt 4, Ch 1 General Cargo Ships for deep tanks, using h as defined in Pt 4, Ch 7, 7.3 Bulkhead stiffeners 7.3.1.

7.3.4 The section modulus of stiffeners of non-watertight fore and aft diaphragms, or transverse wash bulkheads is to be not less than 50 per cent of that required by Pt 4, Ch 7, 7.3 Bulkhead stiffeners 7.3.3. The stiffeners are to be bracketed at both ends.

7.3.5 Tank end bulkheads are generally to be in line with the main hold bulkheads.

7.4 Shell and deck structure

7.4.1 The scantlings of shell and deck longitudinals are to comply with *Pt 4, Ch 7, 7.3 Bulkhead stiffeners 7.3.1*. The scantlings must also satisfy the requirements of *Pt 4, Ch 1 General Cargo Ships, see also Pt 4, Ch 7, 7.6 Structural details 7.6.1*.

7.4.2 The scantlings of side shell frames are to comply with *Pt 4, Ch 7, 6.2 Transverse stiffening*.

7.5 Primary supporting structure

7.5.1 The section modulus and inertia of deck, shell and bulkhead transverses or stringers are to be not less than:

$$Z = 7,5 k S h l^2_e \text{ cm}^3$$

$$I = \frac{2,5}{k} l_e Z \text{ cm}^4$$

using h as defined in *Pt 4, Ch 7, 7.3 Bulkhead stiffeners 7.3.1*. The scantlings of shell and deck members must also satisfy the requirements of *Pt 4, Ch 1 General Cargo Ships* for dry cargo holds.

7.5.2 Primary transverse members are, in general, to be spaced not more than 3,8 m apart where the length, L , is 100 m or less, and $(0,006L + 3,2)$ m apart for lengths greater than 100 m.

7.5.3 Transverses are to be arranged in line with the primary structure at ends of hatchways, or equivalent scarfing arranged. Where the sloped bulkhead or side shell is transversely framed, arrangements are to be made to ensure effective continuity at the ends of the deck transverse.

7.5.4 Where non-watertight transverse diaphragms are arranged instead of open transverses, the thickness of plating is to be in accordance with *Pt 4, Ch 7, 7.2 Bulkhead plating 7.2.3*. The diaphragms are to be efficiently stiffened.

7.6 Structural details

7.6.1 Bracket/diaphragm connections at the bottom of the topside tank are to be of sufficient size and thickness to provide effective rigidity, and care is to be taken to ensure alignment with brackets at the heads of the side frames in the holds, *see also Pt 4, Ch 7, 6.2 Transverse stiffening 6.2.12*. The shell and sloped bulkhead longitudinals supporting the diaphragms are to be derived using the span taken between transverses.

7.6.2 For ships where $L \geq 300$ m a fore and aft diaphragm extending vertically from the deck to the sloping plating of the topside tank is to be arranged at about the half-width of the tank.

7.6.3 Where longitudinal framing is fitted to the side shell, a bracket may be required in way of a rounded gunwale, approximately halfway between transverses and extending to the adjacent shell and deck longitudinal.

■ Section 8

Double bottom structure**8.1 General**

8.1.1 The double bottom is, in general, to be longitudinally framed, but special consideration will be given to proposals for a transverse framing system.

8.1.2 The requirements of *Pt 4, Ch 1, 8 Double bottom structure* are to be applied, together with the requirements of this Section, *see also Pt 4, Ch 7, 2.2 Protection of steelwork 2.2.3*.

8.1.3 Where the double bottom tanks are interconnected with double skin side tanks or combined hopper and top-side tanks, the double bottom scantlings are also to satisfy the requirements of *Table 7.8.1 Strengthening for heavy cargo requirements (3)(c), (3)(d), (4)(c) and (4)(d)* for ballast holds and (3)(c) and (4)(c) in way of dry cargo holds, *see also Pt 4, Ch 1, 6.2 Longitudinal stiffening*.

8.1.4 The requirements given in *Pt 4, Ch 7, 8.8 Allowable hold loading in the flooded condition* are to be applied to bulk carriers which satisfy the following criteria:

- Single skin construction, or double skin construction where any part of the longitudinal bulkhead is located within $B/5$ or 11,5 m, whichever is less, inboard from the ship's side at right angles to the centreline at the assigned summer load line.

- Length, L , of 150 m or above.
- Intended for the carriage of cargoes having bulk densities of 1,0 tonne/m³ or above.

8.1.5 For all bulk carriers where bulk cargoes are discharged by grabs the maximum recommended unladen weight of the grab corresponding to the approved inner bottom plating thickness is to be calculated using the following formulae:

$$P = \left(\frac{s}{k}\right)^2 \frac{10^d}{1,775} \text{ tonnes}$$

where:

$$d = \frac{40,875(t - 1,5)\sqrt{k} + 344,5}{s} - 5,7633$$

P = unladen grab weight, in tonnes

s = spacing of inner bottom longitudinal, in mm

k = higher tensile steel factor as defined in *Pt 4, Ch 7, 1.8 Symbols and definitions 1.8.1*

t = thickness of inner bottom plating, in mm

The maximum recommended unladen weight of the grab rounded up to the next tonne above, is to be recorded in the Loading Manual (see also *Pt 3, Ch 4, 8.2 Loading Manual 8.2.4*), and does not preclude the use of heavier grabs. It is intended as an indication to the Builders, Owners and operators of the increased risk of local damage and the possibility of accelerated diminution of the plating thickness if grabs heavier than this are used regularly to discharge cargo.

8.1.6 Detail design guidelines for stiffeners connecting inner bottom and bottom longitudinals are shown in the *ShipRight FDA Procedure, Structural Detail Design Guide (SDDG)*.

Table 7.8.1 Strengthening for heavy cargo requirements

Symbols	Item	Requirement
<p>L, l_e, D, T, s, S, k, Z and t as defined in Pt 4, Ch 7, 1.8 Symbols and definitions 1.8.1</p> <p>$C_1 =$ a factor varying from 1,0 at $\frac{D}{2}$ to $\frac{75}{225 - 150F_B}$ at base line of ship</p> <p>$C =$ stowage rate, in m³/tonne, and is defined as the volume of the hold excluding the volume contained within the depth of the cargo hatchway divided by the weight of cargo stowed in the hold. The value is not to be taken greater than 0,865</p> <p>F_B as defined in Pt 3, Ch 4, 5.7 Local reduction factors</p> <p>R and θ as defined in Pt 4, Ch 7, 1.8 Symbols and definitions 1.8.1</p> <p>$H =$ height from tank top, at position under consideration, to deck at side amidships, in metres</p> <p>$Y_1 =$ distance from $\frac{D}{2}$ to tank top, in metres</p> <p>$h_0 =$ for plating and stiffeners the vertical distance, in metres, from the inner bottom to the highest point of the tank excluding hatchway</p> <p>$b_1 =$ the larger horizontal distance, in metres, from the tank corner at top of tank either side to the point of plate or stiffener under consideration</p>	(1) Double bottom floors	The spacing of floors, generally, is not to exceed 2,5 m. Scantlings are to comply with the requirements of Pt 4, Ch 1, 8.5 Floors
	(2) Double bottom side girders	The spacing of side girders, generally, is not to exceed 3,7 m. Scantlings are to comply with the requirements of Pt 4, Ch 1, 8.3 Girders
	(3) Inner bottom plating, see Note 3	<p>The thickness of the inner bottom plating in the holds is to be not less than required by the greatest of the following:</p> <p>(a)</p> $t = 0,00136(s + 660)\sqrt[4]{k^2 LT} + 5mm,$ <p>or</p> <p>(b) $t = 0,00455s\sqrt{\frac{Hk}{C}}$ mm, or</p> <p>(c) Where the double bottom tanks are interconnected with double skin side tanks or combined hopper and topside tanks the scantlings are also to satisfy the requirements for deep tanks in Table 1.9.1 Watertight and deep tank bulkhead scantlings in Chapter 1, with the load head $h_4 = h_0 \cos \theta + Rb_1$ m</p> <p>(d) In way of ballast holds the scantlings are also to satisfy the requirements for deep tanks in Table 1.9.1 Watertight and deep tank bulkhead scantlings in Pt 4, Ch 1 General Cargo Ships, with the load head h_4, in metres, measured to the deck at centre, but see also Pt 3, Ch 9, 7 Bottom strengthening for loading and unloading aground if protection against heavy grabs is desired.</p>
	(4) Inner bottom longitudinals see Notes 1 and 2	<p>The section modulus of inner bottom longitudinals is to be not less than the greatest of the following:</p> <p>(a) $Z = 85$ per cent of the Rule value for bottom longitudinals as given in Table 1.6.2 (b) Shell framing (longitudinal) Pt 4, Ch 1 General Cargo Ships, or</p> $(b) Z = \frac{0,0083sl^2 e^{HC_1k}}{\left(1 - 0,233\frac{Y_1}{D}\right)C} \text{ cm}^3 \text{ or}$ <p>(c) Where the double bottom tanks are interconnected with double skin side tanks or combined hopper and topside tanks $Z = 0,0073skh_4 l_e^2$ cm³ where $h_4 = h_0 \cos \theta + Rb_1$ m. Z is not to be less than the requirements for deep tanks in Table 1.9.1 Watertight and deep tank bulkhead scantlings in Pt 4, Ch 1 General Cargo Ships, with the load head h_4, in metres, measured to the highest point of the topside tank, or side tank, or</p> <p>(d) In way of ballast holds the section modulus of the longitudinals is to be not less than required for deep tanks in Table 1.9.1 Watertight and deep tank bulkhead scantlings in Pt 4, Ch 1 General Cargo Ships, with the load head h_4, in metres, measured to the deck at centre</p>

Note 1. If plate girders are fitted alternatively with built or rolled sections, the section modulus as given in (4)(b) may be reduced by 10 per cent.

Note 2. Consideration will be given to the fitting of struts in way of double bottom tanks in ships with homogeneous loading. The arrangement and scantlings are, in general, to be confirmed by direct calculation.

Note 3. See also Pt 4, Ch 7, 8.1 General 8.1.5 for the maximum recommended unladen weight of the grab corresponding to the approved

8.2 Carriage of heavy cargoes

8.2.1 When the notation 'strengthened for heavy cargoes' is to be assigned, the requirements of *Table 7.8.1 Strengthening for heavy cargo requirements* are to be complied with.

8.3 Carriage of heavy cargoes with specified or alternate holds empty

8.3.1 For ships strengthened for heavy cargoes and having a class notation permitting specified or alternate holds to be empty, the requirements of *Pt 4, Ch 7, 8.2 Carriage of heavy cargoes 8.2.1* are to be complied with. In addition the scantlings and arrangements of the primary structure are to be confirmed by additional calculations, see *Pt 4, Ch 7, 11.1 Application*.

8.4 Ships to be classed '100A1 bulk carrier, strengthened for heavy cargoes, any hold may be empty, ESP'

8.4.1 For ships to be classed '100A1 bulk carrier, strengthened for heavy cargoes, any hold may be empty, ESP', the requirements of *Pt 4, Ch 7, 8.2 Carriage of heavy cargoes 8.2.1* and *Pt 4, Ch 7, 8.3 Carriage of heavy cargoes with specified or alternate holds empty 8.3.1* are to be complied with. In addition the value for *C*, the stowage rate in m³/tonne, as defined in *Table 7.8.1 Strengthening for heavy cargo requirements*, is not to be taken greater than 0,60 for each hold.

8.5 Ballast ducts

8.5.1 Where ballast ducts are arranged in lieu of suction and/or filling pipes, the scantlings will be approved as suitable for a specified equivalent static head of water. This head must not be exceeded in service, and details of methods to ensure this are to be submitted. The continuity of the floors is to be maintained in way of the ducts.

8.6 Structural details in way of double bottom tank and hopper tank knuckle

8.6.1 In all dry holds where the double bottom tank and hopper tank knuckle is of radiused construction and the floor spacing is 2,5 m or greater brackets shown as in *Figure 7.8.1 Intermediate brackets at knuckle* are to be arranged mid-length between floors in way of the intersection. The brackets are to be attached to the adjacent inner bottom and hopper longitudinal. The thickness of the brackets is to be in accordance with *Pt 4, Ch 1, 8.5 Floors 8.5.3* but need not exceed 15 mm. This requirement does not apply where the double bottom tank and hopper tank knuckle is of welded construction.

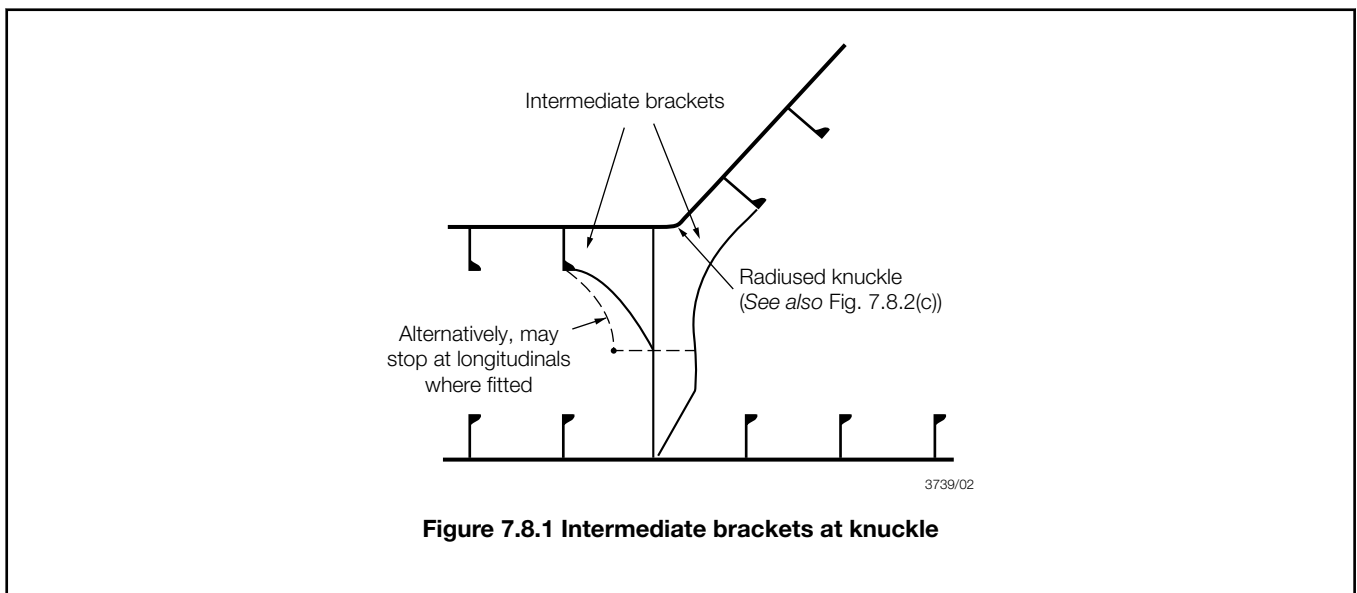

Figure 7.8.1 Intermediate brackets at knuckle

8.6.2 In way of floodable holds, two intermediate bracket arrangements, as shown in *Figure 7.8.1 Intermediate brackets at knuckle*, are to be provided in all cases where the hopper to double bottom knuckle is radiused and are, in general, to be located at each frame space. Where the double bottom tank and hopper tank knuckle is of welded construction, a single intermediate bracket arrangement, as shown in *Figure 7.8.1 Intermediate brackets at knuckle*, is to be provided only when the floor spacing is greater than 2,5 m.

8.6.3 The connections at the intersection are to be as follows:

-
- (a) Where of welded construction the corner scallops in floors and transverses are to be omitted, or closed by welded collars where arranged for purposes of construction. In such cases to ensure satisfactory welding of the collars the radius of the scallops should not be less than 150 mm, see *Figure 7.8.2 Connection at intersection of double bottom and hopper*. Alternatively the scallop may be retained on the hopper tank side provided gusset plates are arranged in line with the inner bottom plating, see *Figure 7.8.2 Connection at intersection of double bottom and hopper*.
- (b) Where of radiused construction the corner scallops are to be omitted, and full penetration welding is to be arranged locally for the connection to the inner bottom plating. The centre of the flange is not to be greater than 70 mm from the side girder, see *Figure 7.8.2 Connection at intersection of double bottom and hopper*.

8.6.4 Detail design guidelines for the connection of hopper tank sloping plating to inner bottom plating are shown in the *ShipRight FDA Procedure, Structural Detail Design Guide (SDDG)*.

8.7 Combined double bottom/hopper tank and topside tank

8.7.1 Where a double bottom/hopper tank is interconnected with a topside tank the dimensions of the connecting trunks or pipes, and the air/overflow pipe(s) and the type of closing appliance are to comply with the requirements of *Pt 5, Ch 13, 12 Air, overflow and sounding pipes*.

8.8 Allowable hold loading in the flooded condition

8.8.1 The requirements of this sub-Section are to be applied as defined in *Pt 4, Ch 7, 8.1 General 8.1.4*.

8.8.2 The maximum load which may be carried in each cargo hold in combination with flood water is to be determined for the most severe homogeneous, non-homogeneous and packed cargo conditions contained in the Loading Manual. The maximum density of cargo intended to be carried in each condition is to be used.

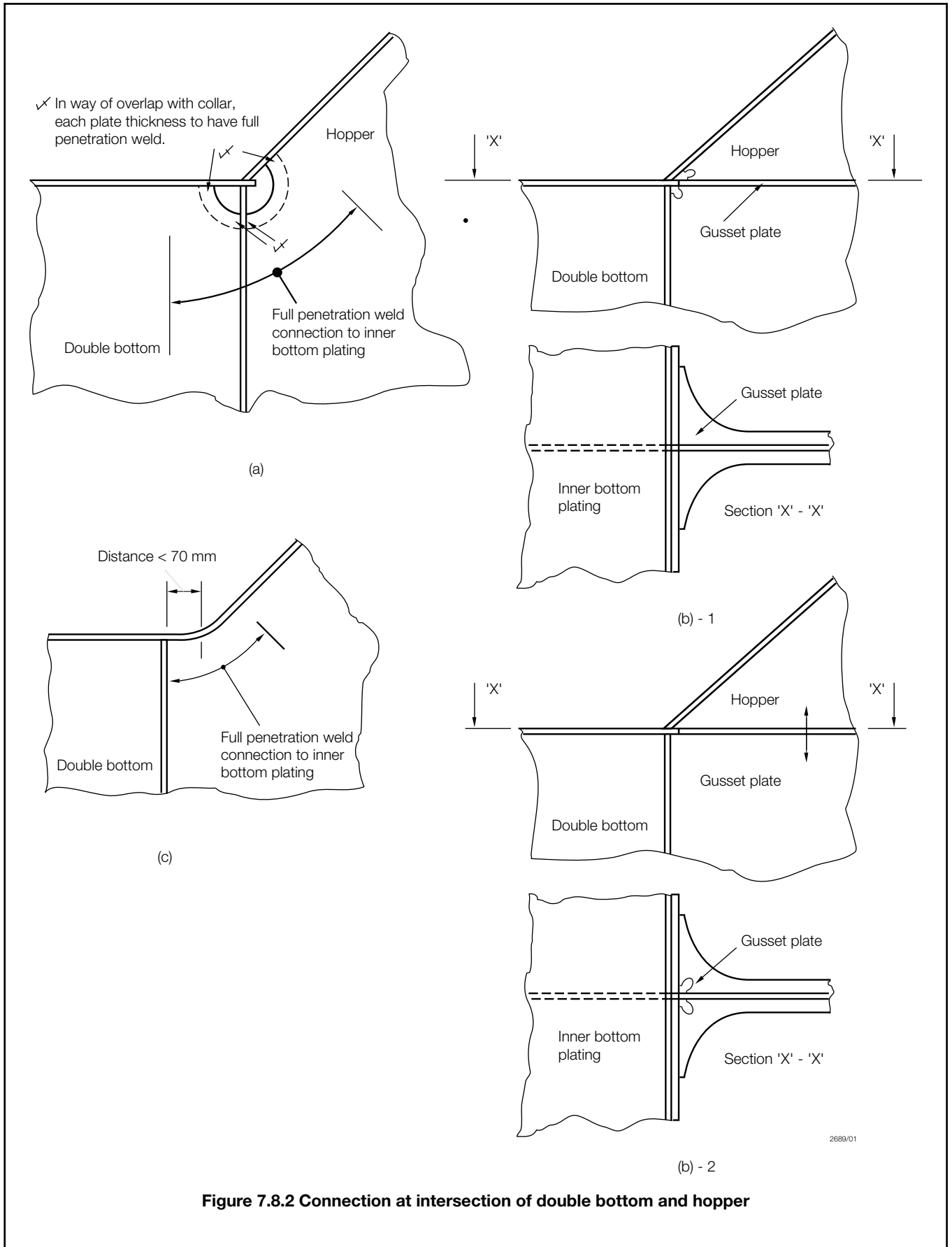

Figure 7.8.2 Connection at intersection of double bottom and hopper

8.8.3 The ship is to be assumed immersed to the draught, T_F , in metres, in way of the flooded cargo hold under consideration. The flooding head, h_f , see *Figure 7.8.3 Loading*, is to be taken as the distance, in metres, measured vertically with the ship in the upright position, from the inner bottom to position, d_f , in metres, from the baseline given by:

- (a) In general:
 - (i) $d_f = D$ for the foremost hold
 - (ii) $d_f = 0,9D$ for other holds
- (b) For ships less than 50 000 tonnes deadweight with Type B freeboard:
 - (i) $d_f = 0,95D$ for the foremost hold
 - (ii) $d_f = 0,85D$ for other holds

where

D = distance, in metres, from the baseline to the freeboard deck at side amidships.

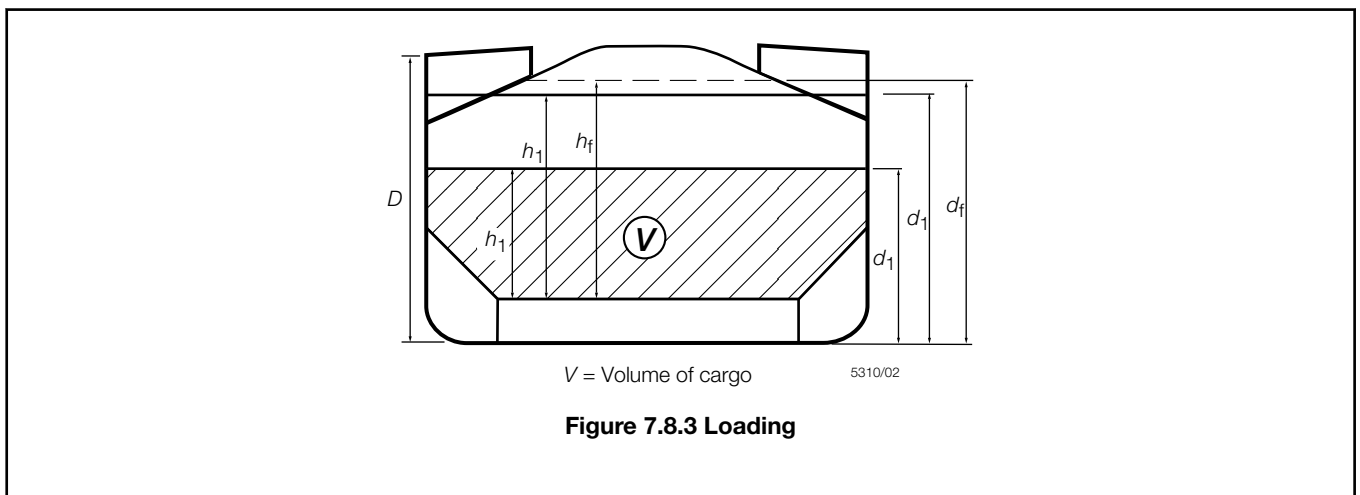

8.8.4 For this application, the double bottom is defined as the structure bounded by the transverse bulkhead lower stools (or bulkhead plating if no lower stools are fitted) and the hopper sides. The floors and girders immediately in way of these structures are excluded.

8.8.5 The determination of shear strength required for the permissible load assessment in *Pt 4, Ch 7, 8.8 Allowable hold loading in the flooded condition 8.8.9*, is to be performed using the net plate thickness, t_{net} , for the floors and girders:

$$t_{net} = t - t_c$$

where

t = as built thickness, in mm

t_c = thickness deduction for corrosion, in mm, generally to be taken as 2,5 mm.

8.8.6 Shear capacity of the double bottom is defined as the sum of the shear strengths for:

- (a) all the floors adjacent to both hoppers, less one half the strength of the floors adjacent to each lower stool (or transverse bulkhead if no lower stool is fitted), see *Figure 7.8.4 Double bottom structure*, and
- (b) all the girders adjacent to the lower stools (or transverse bulkheads if no lower stool is fitted).

Where a girder or floor terminates without direct attachment to the boundary stool or hopper side girder, its shear capacity is to include only that for the effectively connected end.

8.8.7 The shear strengths, S_{f1} , of floors adjacent to hoppers, and S_{f2} , of floors in way of openings in bays nearest to the hoppers, are as follows:

$$S_{f1} = 0,001 A_f \tau_p / \eta_1 \text{ kN (tonne-f)}$$

$$S_{f2} = 0,001 A_{f,h} \tau_p / \eta_2 \text{ kN (tonne-f)}$$

where

A_f = net sectional area, in mm², of floor panel adjacent to hopper

$A_{f,h}$ = net sectional area, in mm², of floor panel in way of opening in the bay closest to hopper

$$\eta_1 = 1,10$$

$$\eta_2 = 1,20 \text{ generally}$$

= 1,10 where appropriate reinforcement is fitted in way of the opening

σ_0 = specified minimum yield stress, in N/mm² (kgf/mm²)

τ_p = permissible shear stress, to be taken equal to the lesser of:

$$\tau_0 = \frac{\sigma_0}{\sqrt{3}} \text{ N/mm}^2 \text{ (kgf/mm}^2\text{) and}$$

$$\tau_c = \frac{162 \sigma_0^{0,6}}{(s_1/t_{net})^{0,8}} \text{ N/mm}^2$$

$$(\tau_c = \frac{65 \sigma_0^{0,6}}{(s_1/t_{net})^{0,8}} \text{ kgf/mm}^2)$$

where

s_1 = spacing of stiffening members, in mm, for the panel under consideration

t_{net} = net thickness, in mm, of the panel under consideration.

For floors adjacent to the stools (or bulkhead plating if no lower stools are fitted), τ_p may be taken as $\frac{\sigma_0}{\sqrt{3}}$ N/mm² (kgf/mm²).

8.8.8 The shear strengths S_{g1} , of girders adjacent to transverse bulkhead lower stools (or transverse bulkheads if no lower stools are fitted), and S_{g2} , of girders in way of the largest openings in bays nearest to the lower stools (or transverse bulkheads if no lower stools are fitted), are as follows:

$$S_{g1} = 0,001 A_g \tau_p / \eta_1 \text{ kN (tonne-f)}$$

$$S_{g2} = 0,001 A_{g,h} \tau_p / \eta_2 \text{ kN (tonne-f)}$$

where

A_g = net sectional area, in mm², of the girder adjacent to transverse bulkhead lower stool (or transverse bulkhead, if no lower stool is fitted)

$A_{g,h}$ = net sectional area, in mm², of the girder in way of the largest openings in the bays closest to the transverse bulkhead lower stool (or transverse bulkhead if no lower stool is fitted)

$$\eta_1 = 1,10$$

$$\eta_2 = 1,15 \text{ generally}$$

= 1,10 where appropriate reinforcement is fitted in way of the opening.

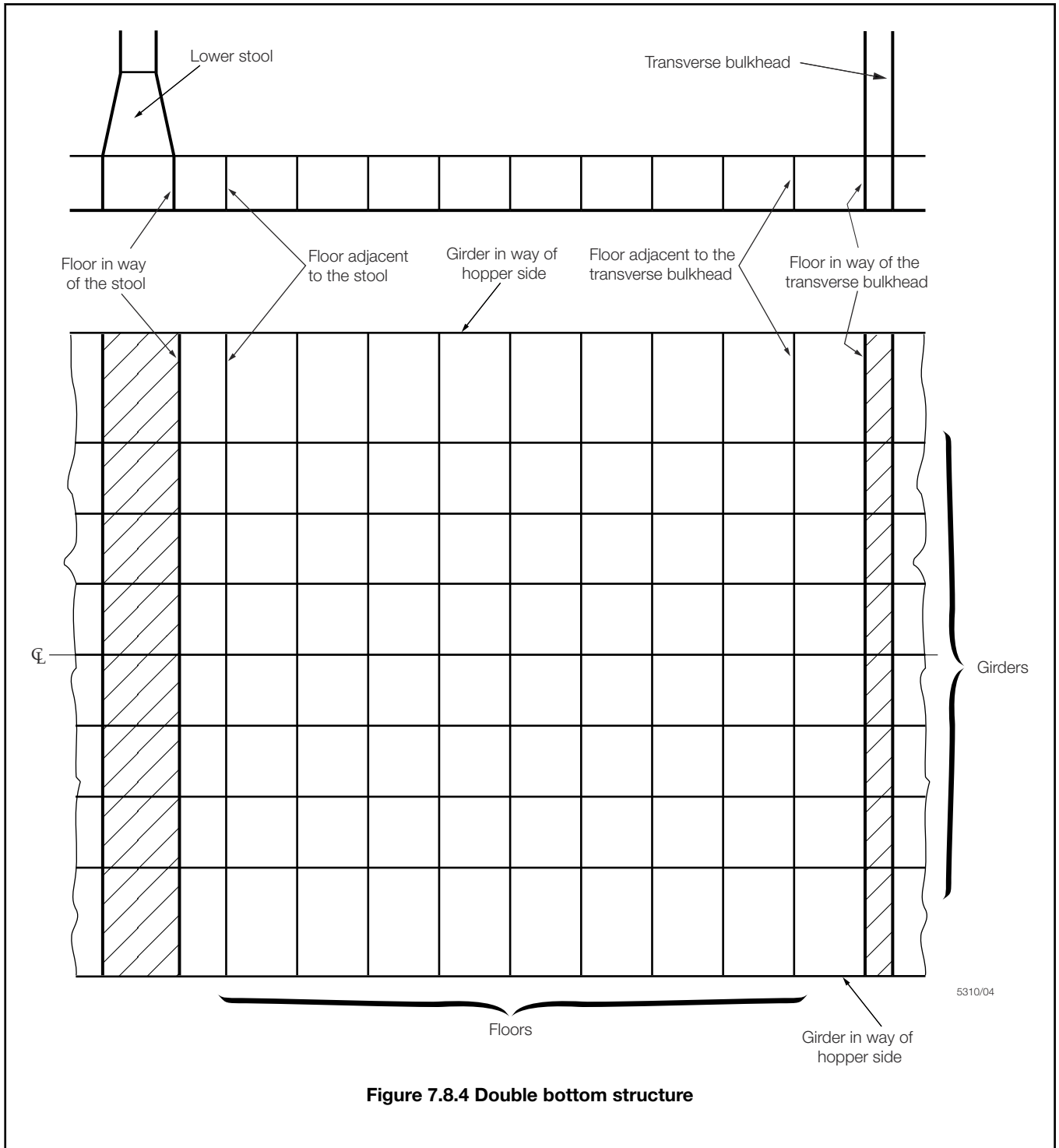

Figure 7.8.4 Double bottom structure

8.8.9 The permissible cargo hold loading, W_p , is given by:

$$W_p = g \rho_c V / F_c \text{ kN}$$

$$(W_p = \rho_c V / F_c \text{ tonne-f})$$

where

d_f, D = as defined in Pt 4, Ch 7, 8.8 Allowable hold loading in the flooded condition 8.8.3

where

g = gravitational constant, 9,81 m/sec²

h_f = flooding head, in metres, as defined in Pt 4, Ch 7, 8.8 Allowable hold loading in the flooded condition 8.8.3

$h_1 = \frac{X}{\rho_c g}$ where Y is in kN/m²

$(h_1 = \frac{X}{\rho_c}$ where Y is in tonne-f/m²)

n = number of floors between transverse bulkhead lower stools or transverse bulkheads, if no lower stools are fitted

s = spacing, in metres, of double bottom longitudinals adjacent to hoppers

$$A_{DB,e} = \left[\begin{array}{c} n \\ \Sigma \\ i=1 \end{array} \right] S_i (B_{DB} - s)$$

$$A_{DB,h} = \left[\begin{array}{c} n \\ \Sigma \\ i=1 \end{array} \right] S_i B_{DB,i}$$

B_{DB} = breadth of double bottom, in metres, between hoppers see Figure 7.8.5 Double bottom breadth

$B_{DB,h}$ = distance, in metres, between openings see Figure 7.8.5 Double bottom breadth

$B_{DB,i} = (B_{DB} - s)$ for floors where shear strength is given by S_{f1}

= $B_{DB,h}$ for floors where shear strength is given by S_{f2}

C_e = shear capacity of the double bottom, in kN (tonne- f), as defined in Pt 4, Ch 7, 8.8 Allowable hold loading in the flooded condition 8.8.6, considering for each floor, the shear strength S_{f1} , see Pt 4, Ch 7, 8.8 Allowable hold loading in the flooded condition 8.8.7, and for each girder, the lesser of the shear strengths S_{g1} and S_{g2} , see Pt 4, Ch 7, 8.8 Allowable hold loading in the flooded condition 8.8.8

C_h = shear capacity of the double bottom, in kN (tonne- f), as defined in Pt 4, Ch 7, 8.8 Allowable hold loading in the flooded condition 8.8.6, considering for each floor, the lesser of the shear strengths S_{f1} and S_{f2} , see Pt 4, Ch 7, 8.8 Allowable hold loading in the flooded condition 8.8.7, and for each girder, the lesser of the shear strengths S_{g1} and S_{g2} , see Pt 4, Ch 7, 8.8 Allowable hold loading in the flooded condition 8.8.8

$F_c = 1,1$ in general

= 1,05 for steel mill products

S_i = spacing of i th floor, in metres

$T_F = d_f - 0,1D$

V = volume, in m³, occupied by cargo at a level h_1

X = the lesser of X_1 and X_2 for bulk cargoes and

$X = X_1$ for steel mill products

where

$$X_1 = \frac{Y + \rho g (T_F - h_f)}{1 + \left(\frac{\rho}{\rho_c}\right) (\mu - 1)}$$

where Y is in kN/m²

where

$$X_1 = \frac{Y + \rho (T_F - h_f)}{1 + \left(\frac{\rho}{\rho_c}\right)(\mu - 1)}$$

where Y is in tonne-f/m²

$$X_2 = Y + \rho g (T_F - h_f \mu)$$

where Y is in kN/m²

$$X_2 = Y + \rho (T_F - h_f \mu)$$

where Y is in tonne-f/m²

Y = the lesser of Y₁ and Y₂ given by:

$$Y_1 = \frac{C_h}{A_{DB,h}}$$

$$Y_2 = \frac{C_e}{A_{DB,e}}$$

μ = permeability of cargo but need not exceed 0,3

= 0,0 for steel mill products

ρ = density of sea water, 1,025 tonne/m³

ρ_c = cargo density, in tonne/m³ (bulk density for bulk cargoes and actual cargo density for steel mill products).

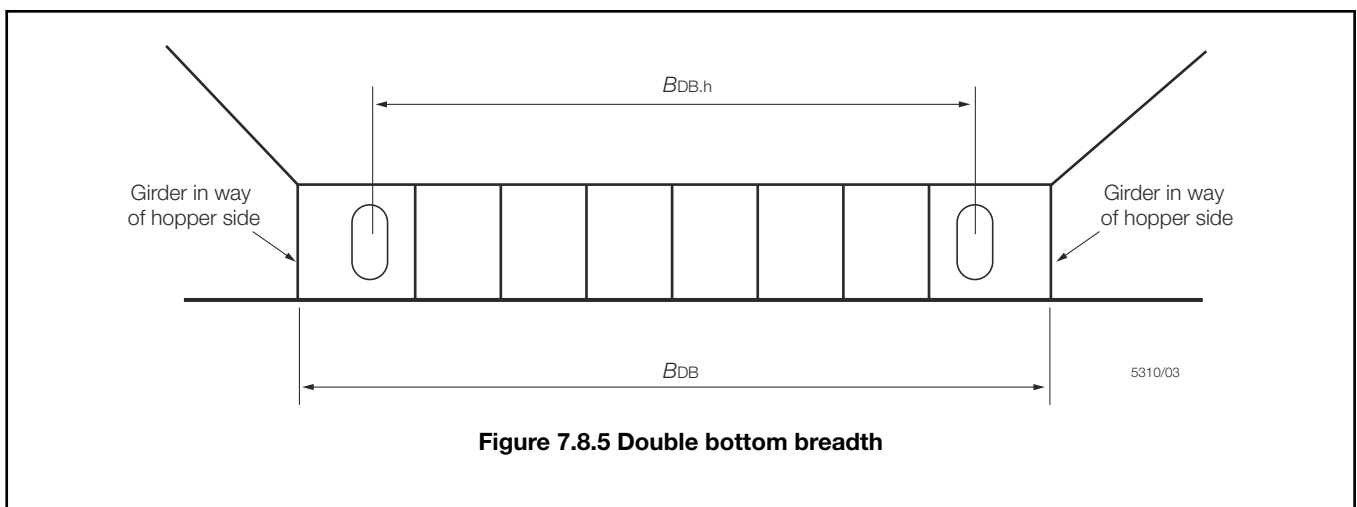

■ **Section 9**
Hopper side tank structure

9.1 General

9.1.1 Provision is made in this Section for longitudinal framing of the hopper side tank, but proposals for transverse framing will be specially considered.

9.1.2 Where oil cargoes are carried the scantlings of the sloped bulkhead are to comply with the requirements of Pt 4, Ch 7, 10.2 Bulkheads supported by stools.

9.1.3 For ships to be classed '**100A1 bulk carrier, strengthened for heavy cargoes, any hold may be empty, ESP**', the requirements of Pt 4, Ch 7, 9.2 Sloped bulkhead plating, Pt 4, Ch 7, 9.3 Sloped bulkhead stiffeners and Pt 4, Ch 7, 9.6 Primary supporting structure are to be complied with. In addition the value for C, the stowage rate in m³/tonne, as defined in Table 7.8.1 Strengthening for heavy cargo requirements, is not be taken greater than 0,60 for each hold.

9.1.4 The buckling requirements of *Pt 3, Ch 4, 7 Hull buckling strength* are also to be satisfied.

9.1.5 The *ShipRight FDA Procedure, Structural Detail Design Guide (SDDG)*, indicates recommended details of structural design configurations around the transverse ring web of the hopper tank.

9.2 Sloped bulkhead plating

9.2.1 The thickness of the sloped bulkhead plating is to be as required by *Pt 4, Ch 1, 8.4 Inner bottom plating and stiffening 8.4.1* but based on actual spacing of sloped bulkhead stiffeners.

9.2.2 Where the ship is regularly discharged by grabs and the optional notation for heavy grabs is not desired (see *Pt 3, Ch 9, 7 Bottom strengthening for loading and unloading aground*), the increase in thickness, as required by *Pt 4, Ch 1, 2.2 Protection of steelwork*, is to be tapered from the inner bottom knuckle to nil at the top corner of the tank.

9.2.3 Where a 'strengthened for heavy cargo notation' is desired, in addition to *Pt 4, Ch 7, 9.2 Sloped bulkhead plating 9.2.2* the thickness of the sloped bulkhead plating is also to comply with the requirements of *Table 7.8.1 Strengthening for heavy cargo requirements (3)(b)* using the actual spacing of stiffeners and with H , in metres, measured vertically from a point one third of each plate width from its lower edge to the upper deck at side.

9.2.4 Where the hopper tanks are interconnected with the topside tanks, or in way of ballast holds, the plating is also to comply with the requirements of *Table 7.8.1 Strengthening for heavy cargo requirements (3)(c) and (3)(d)*, whichever is appropriate.

9.3 Sloped bulkhead stiffeners

9.3.1 The scantlings of sloped bulkhead stiffeners are to be as required for inner bottom longitudinals, see *Pt 4, Ch 7, 8 Double bottom structure*. In ships strengthened for heavy cargoes, the scantlings of the stiffeners are to be derived from *Table 7.8.1 Strengthening for heavy cargo requirements* using a head for heavy cargo measured vertically from the mid-point of the effective length to the underside of the topside tank sloped bulkhead. Where the hopper tanks are interconnected with the topside tanks, or in way of ballast holds, the scantlings of the stiffeners are also to comply with the requirements of *Table 7.8.1 Strengthening for heavy cargo requirements (4)(c) and (4)(d)*, whichever is appropriate. For higher tensile steel longitudinals the requirements of *Pt 4, Ch 1, 6.2 Longitudinal stiffening 6.2.3* are to be complied with where applicable, see also *Pt 4, Ch 7, 9.7 Structural details 9.7.1*.

9.4 Shell and bilge stiffeners

9.4.1 The scantlings of the shell and bilge longitudinals are to comply with the requirements of *Pt 4, Ch 1, 6 Shell envelope framing*.

9.5 Tank end bulkheads

9.5.1 The scantlings of tank end bulkheads are to comply with the requirements for deep tanks in *Table 1.9.1 Watertight and deep tank bulkhead scantlings*. Where the hopper tanks are interconnected with the topside tanks, the scantlings are to be derived, using the load head h_4 , in metres, from *Table 7.8.1 Strengthening for heavy cargo requirements (3)(c) and (4)(c)*, as appropriate.

9.6 Primary supporting structure

9.6.1 Transverses supporting longitudinal stiffening are to comply with the requirements of *Table 7.9.1 Hopper tank primary structure*, and are to be in line with the double bottom floors.

9.7 Structural details

9.7.1 Bracket/diaphragms at the top of the hopper tank are to be of sufficient size and thickness to provide effective rigidity, and care is to be taken to ensure alignment with brackets at the bottom of the side frames in the holds. The shell and sloped bulkhead longitudinals supporting the diaphragms are to be derived using the span taken between transverses, see also *Pt 4, Ch 7, 6.2 Transverse stiffening 6.2.11*.

Table 7.9.1 Hopper tank primary structure

Item	Modulus, in cm ³	Inertia, in cm ⁴
(1) Bottom and side shell transverses	$Z = 11,71\rho kSh_l e^2$	$I = \frac{2,5}{k}l_e Z$
(2) Sloped bulkhead transverses	The greater of: (a) $Z = 11,71\rho kSh_1 l_e^2$ (b) $Z = 6,6 \frac{kSH_H l_e^2}{C} \tan$	$I = \frac{2,5}{k}l_e Z$ $I = \frac{1,85}{k}l_e Z$
Symbols		
<p>S, k, I_e, Z, l, ρ = as defined in Pt 4, Ch 7, 1.7 Information required for non-CSR bulk carriers 1.7.1</p> <p>h = distance, in metres, from the mid-point of the effective length to the upper deck at side</p> <p>h₁ = the greater of the distance, in metres, from the midpoint of the effective length to the top of the tank or half the distance, in metres, to the top of the overflow, or in way of cargo oil or ballast holds: the distance from the tank top to the deck at centre, or where the hopper tank is interconnected with the topside tank: the load head h₄, as derived from Table 7.8.1 Strengthening for heavy cargo requirements(4)(c), whichever is the greatest</p> <p>C = stowage rate, in m³/tonne, as defined in Table 7.8.1 Strengthening for heavy cargo requirements. For bulk carriers without the notation 'strengthened for heavy cargoes', the value to be used is 1,39 m³/tonne. For bulk carriers with the notation 'strengthened for heavy cargoes', the actual stowage rate is to be used, but the value is not to be taken greater than 0,865 m³/tonne.</p> <p>H_H = distance, in metres, measured vertically from the mid-point of the effective length to the underside of the topside tank sloped bulkhead</p>		

■ **Section 10**
Bulkheads

10.1 General

10.1.1 The requirements of Pt 4, Ch 1, 9 Bulkheads are to be applied, together with the requirements of this Section.

10.1.2 Where vertically corrugated transverse watertight bulkheads are fitted, the scantlings and arrangements are also to satisfy the requirements of Pt 4, Ch 7, 10.4 Vertically corrugated transverse watertight bulkheads – Application and definitions. Other transverse watertight bulkhead types will be specially considered.

10.1.3 In way of ballast holds, the scantlings are to satisfy the requirements of Table 1.9.1 Watertight and deep tank bulkhead scantlings in Pt 4, Ch 1 General Cargo Ships for deep tanks with the load head, h₄, in metres, taken to the deck at centre. This includes the scantlings of vertically corrugated and double plate transverse bulkheads supported by stools. In addition, the thickness of corrugations is to be not less than given by Pt 4, Ch 7, 10.5 Vertically corrugated transverse watertight bulkheads – Scantling assessment 10.5.8 for watertight corrugated bulkheads. Alternatively, the scantlings may be based on direct calculations which are to be submitted.

10.1.4 All bulk carriers to be classed **'100A1 bulk carrier, strengthened for heavy cargoes, any hold may be empty, ESP'** are to be arranged with top and bottom stools. The requirements of Pt 4, Ch 7, 10.2 Bulkheads supported by stools are to be complied with as appropriate.

10.2 Bulkheads supported by stools

10.2.1 The stools are to be reinforced with plate diaphragms or deep webs, and in bottom stools the diaphragms are to be aligned with double bottom side girders. Continuity is also to be maintained between the diaphragms and the bulkhead corrugations for 90° corrugations.

10.2.2 The sloping plate of bottom stools is to be aligned with double bottom floors. Particular attention is to be given to the through thickness properties of the inner bottom plating and continuity at the connection to the inner bottom, and to the through thickness properties of the bottom stool shelf plate, see *Ch 3, 8 Plates with specified through thickness properties of the Rules for the Manufacture, Testing and Certification of Materials* regarding requirements for plates with specified through thickness properties.

10.2.3 An efficient system of reinforcement is to be arranged in line with the hold transverse bulkheads or bulkhead stools at the intersection with the sloped plating of the hopper and topside tanks. The reinforcement fitted in the tanks is to consist of girders or intercostal bulb plate or equivalent stiffeners fitted between, and connected to, the sloped bulkhead longitudinals.

10.2.4 The shelf plates of the bulkhead stools are to be arranged to align with the longitudinals in the hopper and topside tanks. Where sloping shelf plates are fitted to stools, suitable scarfing is to be arranged in way of the connections of the stools to the adjoining structures.

10.2.5 The *ShipRight FDA Procedure, Structural Detail Design Guide (SDDG)*, indicates recommended structural design configurations in the critical areas of the lower stool and of the upper boundaries.

10.3 Structural details in way of holds confined to dry cargoes

10.3.1 In dry cargo holds where transverse bulkheads are arranged without bottom stools, the stiffeners and brackets of plane bulkheads, and rectangular corrugations of corrugated bulkheads, are to be aligned with floors and inner bottom longitudinals. In the case of non-rectangular corrugations, the flanges are to be aligned with floors, but consideration will be given to the fitting of a substantial transverse girder in place of one of the floors.

10.3.2 Where transverse corrugated bulkheads are arranged without top stools, transverse beams are to be arranged under the deck in way.

10.4 Vertically corrugated transverse watertight bulkheads – Application and definitions

10.4.1 Where corrugated transverse watertight bulkheads are fitted, the scantlings are to be determined in accordance with the following requirements.

10.4.2 For ships of length, L , 190 m or above, the vertically corrugated transverse bulkheads are to be fitted with a bottom stool and, generally, with a top stool below the deck. The requirements of *Pt 4, Ch 7, 10.6 Vertically corrugated transverse bulkheads – Support structure at ends* are to be complied with as appropriate.

10.4.3 The loads to be considered as acting on the bulkheads are those given by the combination of cargo loads with those induced by the flooding of one hold adjacent to the bulkhead under consideration. The most severe combinations of cargo induced loads and flooding loads are to be used for the determination of the scantlings of each bulkhead, depending on the specified design loading conditions:

- (a) homogeneous loading conditions,
- (b) non-homogeneous loading conditions (excluding part loading conditions associated with multi-port loading and unloading),
- (c) packed cargo conditions (such as steel mill products).

The individual flooding of loaded and empty holds is to be considered, but the pressure used in the assessment is not to be less than that obtained for flood water alone. Holds containing packed cargo are to be treated as empty holds.

10.4.4 The cargo surface is to be taken as horizontal and at a distance d_1 , in metres, from the base line, see *Figure 7.10.1 Cargo hold dimensions*, where d_1 is calculated taking into account the cargo properties and the hold dimensions. Unless the ship is designed to carry only cargo of bulk density greater than or equal to 1,78 tonne/m³ in non-homogeneous loading conditions, the maximum mass of cargo which may be carried in the hold is to be taken as filling that hold to the upper deck level at centreline. A permeability, μ , of 0,3 and angle of repose, ψ , of 35° is to be assumed for this application.

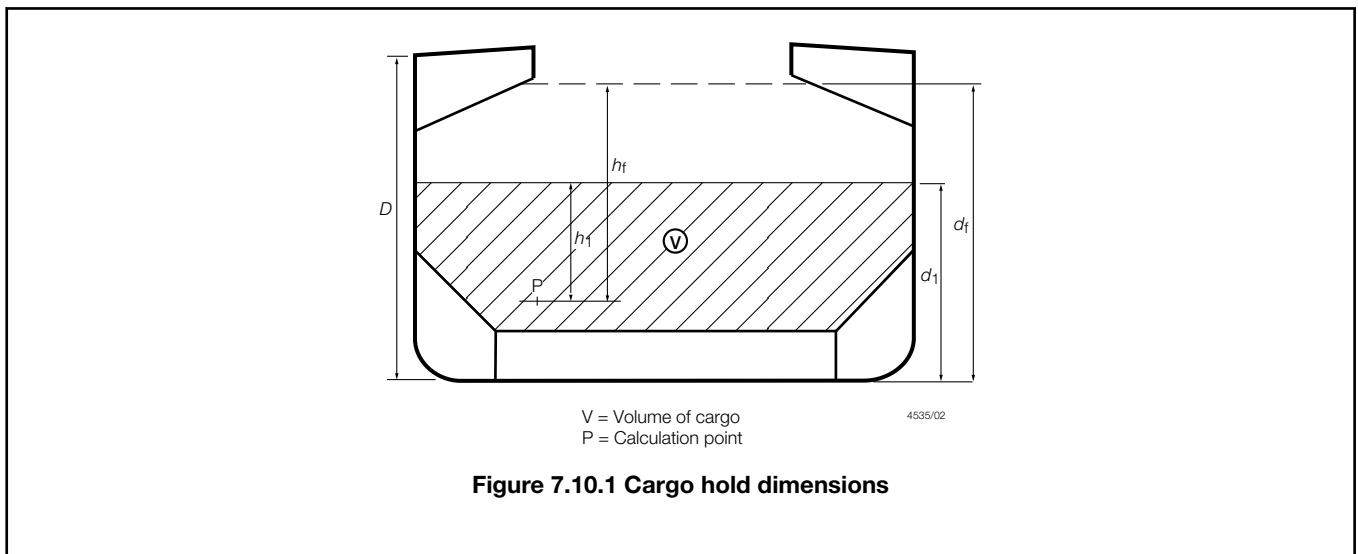

10.4.5 An homogeneous load condition is defined as one where the ratio between the highest and the lowest filling levels, d_1 , in adjacent holds does not exceed 1,20. For this purpose, where a loading condition includes cargoes of different densities, equivalent filling levels are to be calculated for all holds on the basis of a single reference value of cargo density, which can be the minimum to be carried.

10.4.6 The permeability, μ , may be taken as 0,3 for ore, coal and cement cargoes. The bulk density and angle of repose, ψ , may generally be taken as 3,0 tonne/m³ and 35° respectively for iron ore and 1,3 tonne/m³ and 25° respectively for cement.

10.4.7 The flooding head, h_f , see *Figure 7.10.1 Cargo hold dimensions*, is the distance, in metres, measured vertically with the ship in the upright position, from the location P, under consideration, to a position d_f , in metres, from the base line as given in *Table 7.10.1 Flooding head*.

10.4.8 In considering a flooded hold, the total load is to be taken as that of the cargo and flood water at the appropriate permeability. Where there is empty volume above the top of the cargo, this is to be taken as flooded to the level of the flooding head.

10.4.9 Corrugations may be constructed of flanged plates or fabricated from separate flange and web plates, which may be of different thicknesses. The corrugation angle is to be not less than 55°, see *Figure 7.10.2 Dimensions of bulkhead corrugation angles*.

10.4.10 The term net plate thickness is used to describe the calculated minimum thickness of plating of the web, t_w , or flange, t_f . The plate thickness to be fitted is the net plate thickness plus a corrosion addition of 3,5 mm.

10.5 Vertically corrugated transverse watertight bulkheads – Scantling assessment

10.5.1 The bending moment M , in kNm (tonne-f m), for the bulkhead corrugations is given by:

$$M = \frac{Fl}{8}$$

where

l = span of the corrugation, in metres, to be measured between the internal ends of the bulkhead upper and lower stools in way of the neutral axis of the corrugations or, where no stools are fitted, from inner bottom to deck, see *Figure 7.10.2 Dimensions of bulkhead corrugation angles* and *Figure 7.10.3 Scantling assessment*. The lower end of the upper stool is not to be taken greater than a distance from the deck at the centreline equal to:

- = 3 times the depth of the corrugation, in general, or
- = 2 times the depth of the corrugation, for rectangular stools

F = resultant force, in kN (tonne-f), see *Table 7.10.3 Resultant pressure and force*.

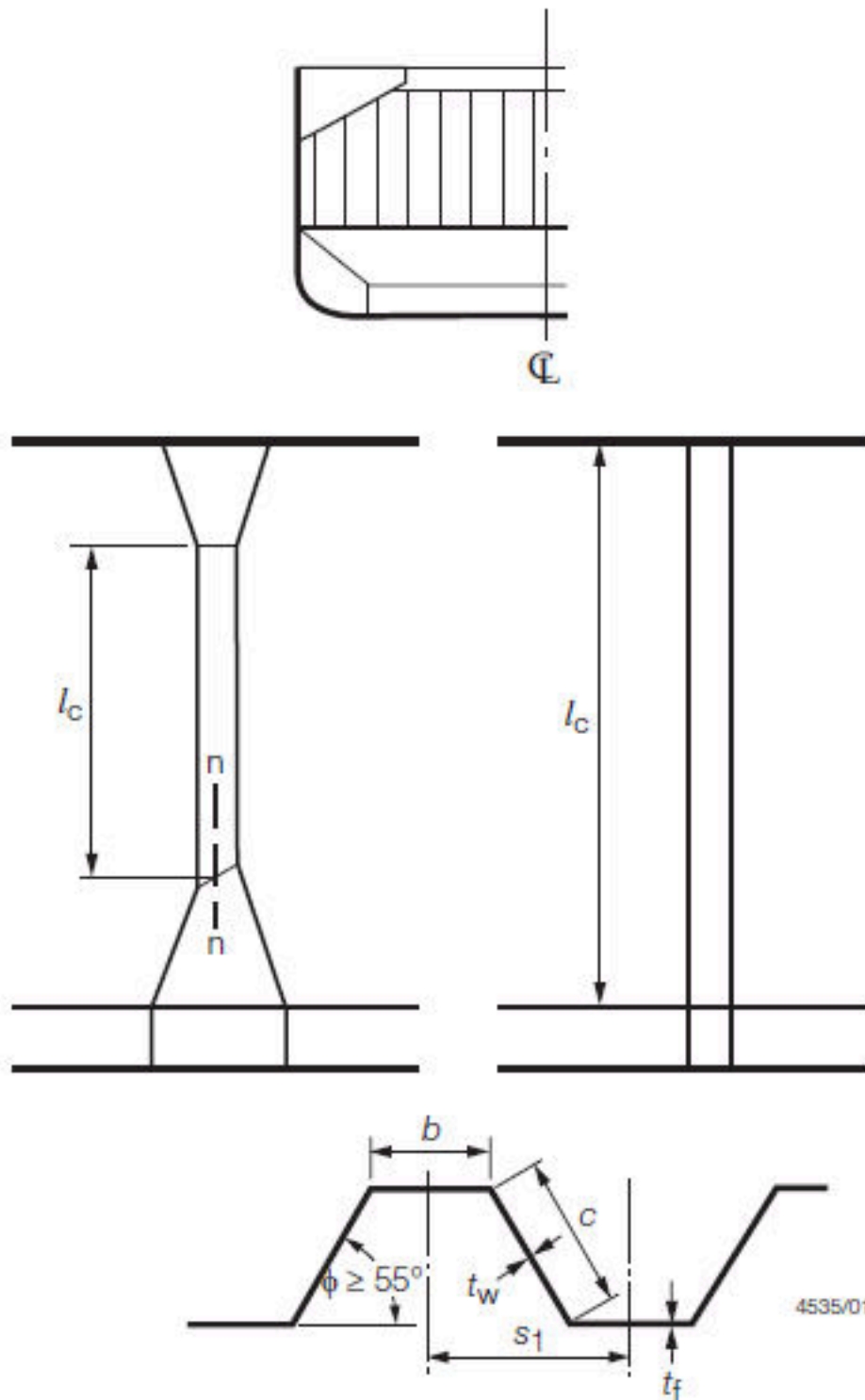

n = neutral axis of the corrugations
 s = $\max (b; c)$

Figure 7.10.2 Dimensions of bulkhead corrugation angles

10.5.2 The shear force, Q , in kN (tonne-f) at the lower end of the bulkhead corrugation is given by:

$$Q = 0,8F$$

where F is defined in Pt 4, Ch 7, 10.5 Vertically corrugated transverse watertight bulkheads – Scantling assessment 10.5.1.

Table 7.10.1 Flooding head

Item	Bulkhead location	Bulk carriers with Type B freeboard and deadweight < 50 000 tonnes	Other bulk carriers
I ⁽¹⁾	Between holds 1 and 2	$d_f = 0,95D$	$d_f = D$
	Elsewhere	$d_f = 0,85D$	$d_f = 0,9D$
II ⁽¹⁾	Between holds 1 and 2	$d_f = 0,9D$	$d_f = 0,95D$
	Elsewhere	$d_f = 0,8D$	$d_f = 0,85D$

Note 1. Item **II** is to be used for non-homogeneous loading conditions where the bulk cargo density is less than 1,78 tonne/m³. Otherwise, Item **I** is to be used.

Note 2. D = distance, in metres, from the base line to the freeboard deck at side amidships, see Fig 7.10.1.

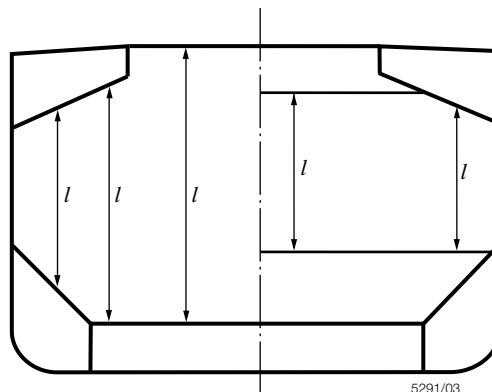

Figure 7.10.3 Scantling assessment

10.5.3 The section modulus of the corrugations is to be calculated using net plate thicknesses. At the lower end, the following requirements apply:

- (a) An effective width of compression flange, b_{ef} , not greater than given in Pt 4, Ch 7, 10.5 Vertically corrugated transverse watertight bulkheads – Scantling assessment 10.5.7, is to be used.
- (b) Where corrugation webs are not supported by local brackets below the shelf plate (or below the inner bottom if no lower stool is fitted), they are to be assumed 30 per cent effective in bending. Otherwise, the full area of web plates may be used, see also Pt 4, Ch 7, 10.5 Vertically corrugated transverse watertight bulkheads – Scantling assessment 10.5.3.
- (c) Where effective shedder plates are fitted, see Figure 7.10.4 Symmetric shedder plates and Figure 7.10.5 Asymmetric shedder plates, the net area of the corrugation flange plates, in cm², may be increased by the lesser of:

$$2,5b\sqrt{(t_f t_{sh})} \text{ and } 2,5b t_f$$

where

b = width of corrugation flange, in metres, see *Figure 7.10.2 Dimensions of bulkhead corrugation angles*

t_f = net flange plate thickness, in mm

t_{sh} = net shedder plate thickness, in mm

A shedder plate is considered effective when it:

- is not knuckled; and
 - is welded to the corrugations and the lower stool shelf plate by one-side penetration welds or equivalent; and
 - has a minimum slope of 45° and lower edges in line with the stool side plating; and
 - has a thickness not less than 0,75 times the thickness of the corrugation flanges; and
 - has material properties at least equal to those of the corrugation flanges.
- (d) Where effective gusset plates are fitted, see *Figure 7.10.6 Symmetric gusset/shedder plates* and *Figure 7.10.7 Asymmetric gusset/shedder plates* the net area of the corrugation flange plates, in cm², may be increased by:

$$7 h_g t_f$$

where

h_g = height of the gusset plate, in metres, but is not to be taken greater than $\frac{10}{7} s_{gu}$

t_f = net flange plate thickness, in mm

s_{gu} = width of the gusset plate, in metres

A gusset plate is considered effective when it:

- is fitted in combination with an effective shedder plate as defined in *Pt 4, Ch 7, 10.5 Vertically corrugated transverse watertight bulkheads – Scantling assessment 10.5.3*; and
 - has height not less than half the flange plate width; and
 - is fitted in line with the stool side plating; and
 - has thickness and material properties at least equal to those of the flanges; and
 - is welded to the top of the lower stool by full penetration welds and to the corrugations and shedder plates by one-side penetration welds or equivalent.
- (e) Where the corrugation is welded to a sloping stool shelf plate, set at an angle of not less than 45° to the horizontal, the corrugation webs may be taken as fully effective in bending. Where the slope is less than 45°, the effectiveness is to be assessed by linear interpolation between fully effective at 45° and the appropriate value from *Pt 4, Ch 7, 10.5 Vertically corrugated transverse watertight bulkheads – Scantling assessment 10.5.3* at 0°. Where effective gusset plates are also fitted, the area of the flange plates may be increased in accordance with *Pt 4, Ch 7, 10.5 Vertically corrugated transverse watertight bulkheads – Scantling assessment 10.5.3*. No increase is permitted in the case where shedder plates are fitted without gussets.

Table 7.10.2 Bulkhead pressure and force

Item	Pressure, kN/m ² (tonne-f/m ²)	Force, kN (tonne-f)
(1) In non-flooded bulk cargo holds	$p_c = g \rho_c h_1 \tan^2 \theta$ $(p_c = \rho_c h_1 \tan^2 \theta)$	$F_c = 0,5 \rho_c g s_1 (d_1 - h_{DB} - h_{LS})^2 \tan^2 \theta$ $(F_c = 0,5 \rho_c s_1 (d_1 - h_{DB} - h_{LS})^2 \tan^2 \theta)$

Bulk Carriers

Part 4, Chapter 7

Section 10

<p>(2) In flooded bulk cargo holds, when $d_f \geq d_1$</p> <p>(a) For positions between d_1 and d_f from base line</p> <p>(b) For positions at a distance lower than d_f from base line</p>	<p>$\rho_{cf} = g\rho h_f$</p> <p>$(\rho_{cf} = \rho h_f)$</p> <p>$\rho_{cf} = g(\rho h_f + (\rho_c - \rho(1-\mu))h_1 \tan^2 \theta)$</p> <p>$(\rho_{cf} = (\rho h_f + (\rho_c - \rho(1-\mu))h_1 \tan^2 \theta))$</p>	<p>$F_{cf} = 0,5s_1(\rho g(d_f - d_1)^2 + (\rho g(d_f - d_1) + \rho_{le})(d_1 - h_{DB-h_{LS}}))$</p> <p>$(F_{cf} = 0,5s_1(\rho(d_f - d_1)^2 + (\rho(d_f - d_1) + \rho_{le})(d_1 - h_{DB-h_{LS}})))$</p>
<p>(3) In flooded bulk cargo holds, when $d_f < d_1$</p> <p>(a) For positions between d_1 and d_f from base line</p> <p>(b) For positions at a distance lower than d_f from base line</p>	<p>$\rho_{cf} = g\rho_c h_1 \tan^2 \theta$</p> <p>$(\rho_{cf} = \rho_c h_1 \tan^2 \theta)$</p> <p>$\rho_{cf} = g(\rho h_f + (\rho_c h_1 - \rho(1-\mu)h_f) \tan^2 \theta)$</p> <p>$(\rho_{cf} = (\rho h_f + (\rho_c h_1 - \rho(1-\mu)h_f) \tan^2 \theta))$</p>	<p>$F_{cf} = 0,5s_1(\rho_c g(d_1 - d_f)^2 \tan^2 \theta + (\rho_c g(d_1 - d_f) \tan^2 \theta + \rho_{le})(d_f - h_{DB-h_{LS}}))$</p> <p>$(F_{cf} = 0,5s_1(\rho_c(d_1 - d_f)^2 \tan^2 \theta + (\rho_c(d_1 - d_f) \tan^2 \theta + \rho_{le})(d_f - h_{DB-h_{LS}})))$</p>
<p>(4) In flooded empty holds</p>	<p>$\rho_f = g\rho h_f$</p> <p>$(\rho_f = \rho h_f)$</p>	<p>$F_f = 0,5s_1 \rho g(d_f - h_{DB-h_{LS}})^2$</p> <p>$(F_f = 0,5s_1 \rho(d_f - h_{DB-h_{LS}})^2)$</p>

Symbols
<p>d_1 see Pt 4, Ch 7, 10.4 Vertically corrugated transverse watertight bulkheads – Application and definitions 10.4.7</p> <p>d_1 = vertical distance, in metres, from the base line to the top of the cargo, see Figure 7.10.1 Cargo hold dimensions</p> <p>g = gravitational constant, 9,81 m/sec²</p> <p>h_{DB} = height of double bottom, in metres</p> <p>h_f = flooding head, see Pt 4, Ch 7, 10.4 Vertically corrugated transverse watertight bulkheads – Application and definitions 10.4.7</p> <p>h_{LS} = mean height of lower stool, in metres</p> <p>h_1 = vertical distance, in metres, from the calculation point to the top of the cargo, see Figure 7.10.1 Cargo hold dimensions</p> <p>p_c, p_{cf}, p_f = pressure on the bulkhead at the point under consideration, in kN/m² (tonne-f/m²)</p> <p>p_{le} = pressure at the lower end of the corrugation, in kN/m² (tonne-f/m²)</p> <p>s_1 = spacing of the corrugations, in metres, see Figure 7.10.2 Dimensions of bulkhead corrugation angles</p> <p>ρ = density of sea water = 1,025 tonne/m³</p> <p>ρ_c = bulk cargo density, in tonne/m³</p> <p>θ = 45° - ($\psi/2$)</p> <p>ψ = angle of repose of the cargo, in degrees</p> <p>μ = permeability of cargo, see Pt 4, Ch 7, 10.4 Vertically corrugated transverse watertight bulkheads – Application and definitions 10.4.6</p>

Table 7.10.3 Resultant pressure and force

Loading condition	Resultant pressure kN/m ² (tonne-f/m ²)	Resultant force kN (tonne-f)
Homogeneous	$p_r = p_{cf} - 0,8p_c$	$F = F_{cf} - 0,8F_c$
Non-homogeneous	$p_r = p_{cf}$	$F = F_{cf}$
Flood water alone (adjacent holds empty)	$p_r = p_f$	$F = F_f$
NOTE		
For symbols, see Table 7.10.2.		

10.5.4 The section modulus of corrugations at cross-sections other than the lower end is to be calculated with fully effective webs and an effective compression flange width, b_{ef} not greater than given in Pt 4, Ch 7, 10.5 Vertically corrugated transverse watertight bulkheads – Scantling assessment 10.5.7.

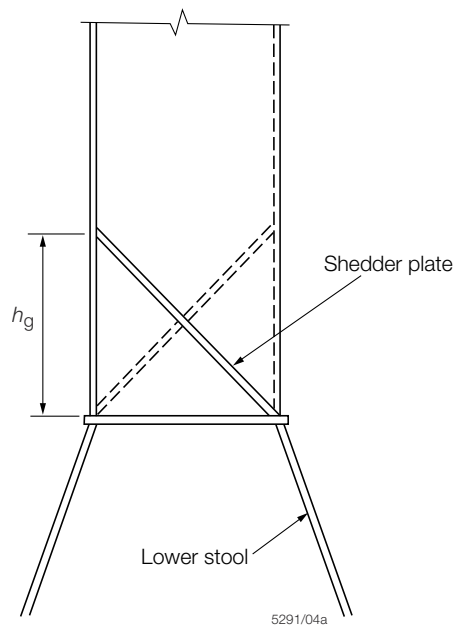

Figure 7.10.4 Symmetric shedder plates

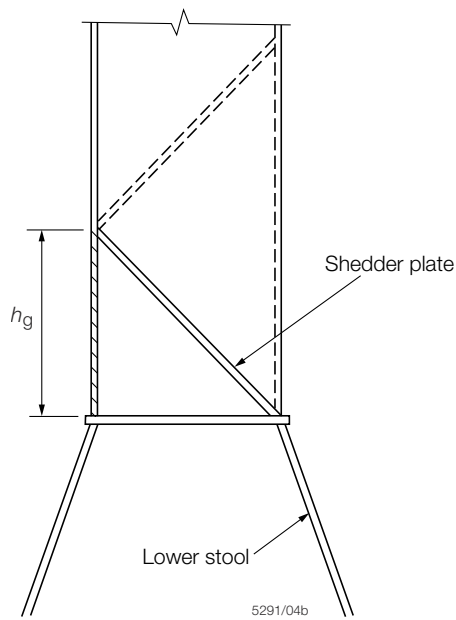

Figure 7.10.5 Asymmetric shedder plates

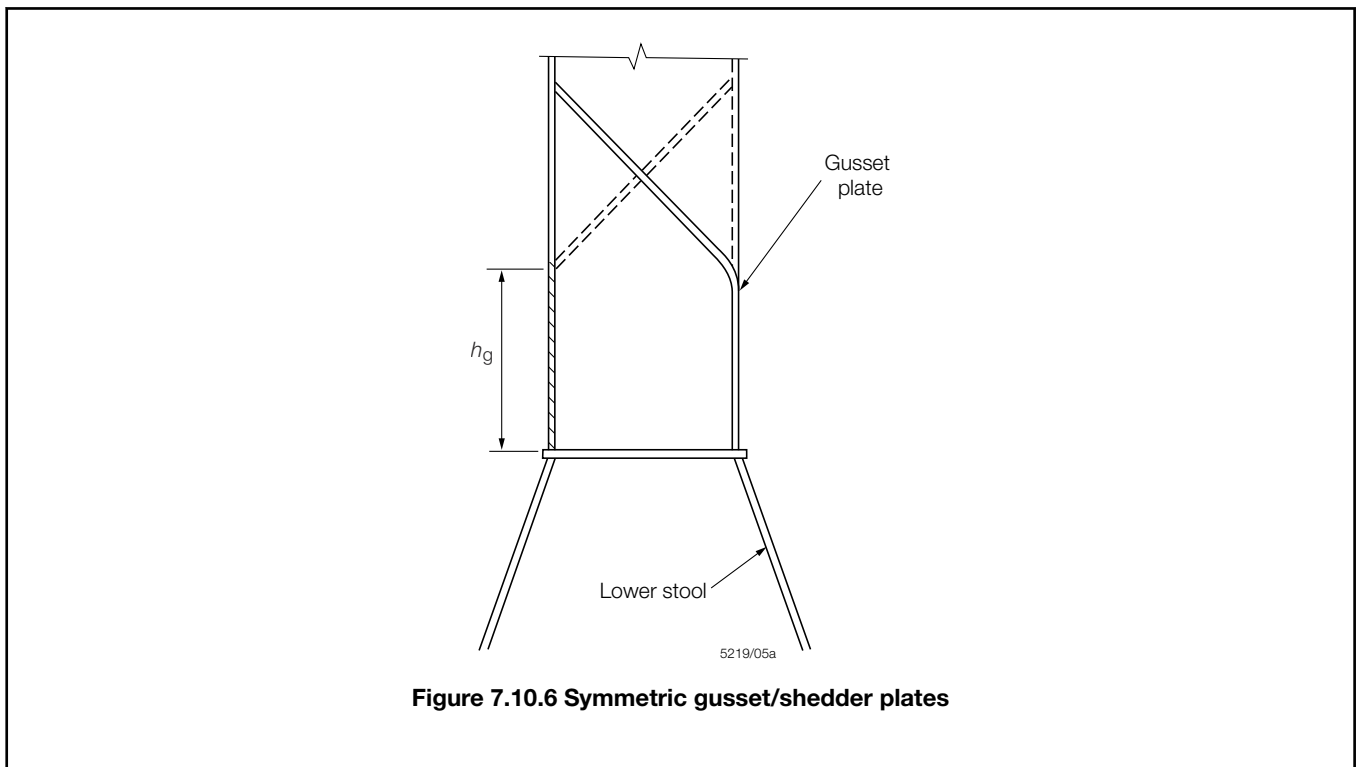

Figure 7.10.6 Symmetric gusset/shedder plates

10.5.5 The bending capacity of the bulkhead corrugations is to comply with the following relationship:

$$\frac{1000M}{0,5Z_{le} \sigma_{p,le} + Z_m \sigma_{p,m}} \leq 0,95$$

where

M = bending moment, in kNm (tonne-f m), see Pt 4, Ch 7, 10.5 Vertically corrugated transverse watertight bulkheads – Scantling assessment 10.5.1

Z_{le} = section modulus at the lower end of the corrugations, in cm³

Z_m = section modulus at mid-span of the corrugations, in cm³

$\sigma_{p,le}$ = permissible bending stress at the lower end of the corrugations, in N/mm² (kgf/mm²)

$\sigma_{p,m}$ = permissible bending stress at mid-span of the corrugations, in N/mm² (kgf/mm²)

In the above expression Z_{le} , in cm³, is not to be taken greater than Z'_{le} where

$$Z'_{le} = Z_g + \left(\frac{1000 Q h_g - 0,5 h_g^2 s_1 p_g}{\sigma_{p,le}} \right)$$

and Z_m is not to exceed the lesser of $1,15Z_{le}$ and $1,15Z'_{le}$

where

h_g = height of the gusset plate, in metres

p_g = resultant pressure calculated in way of the middle of the shedder or gusset plates as appropriate, in kN/m² (tonne- f/m²)

s_1 = spacing of the corrugations, in metres

Q = shear force, in kN (tonne-f), see Pt 4, Ch 7, 10.5 Vertically corrugated transverse watertight bulkheads – Scantling assessment 10.5.2

where

Z_g = section modulus of the corrugations in way of the upper end of shedder or gusset plates as appropriate, in cm^3 .

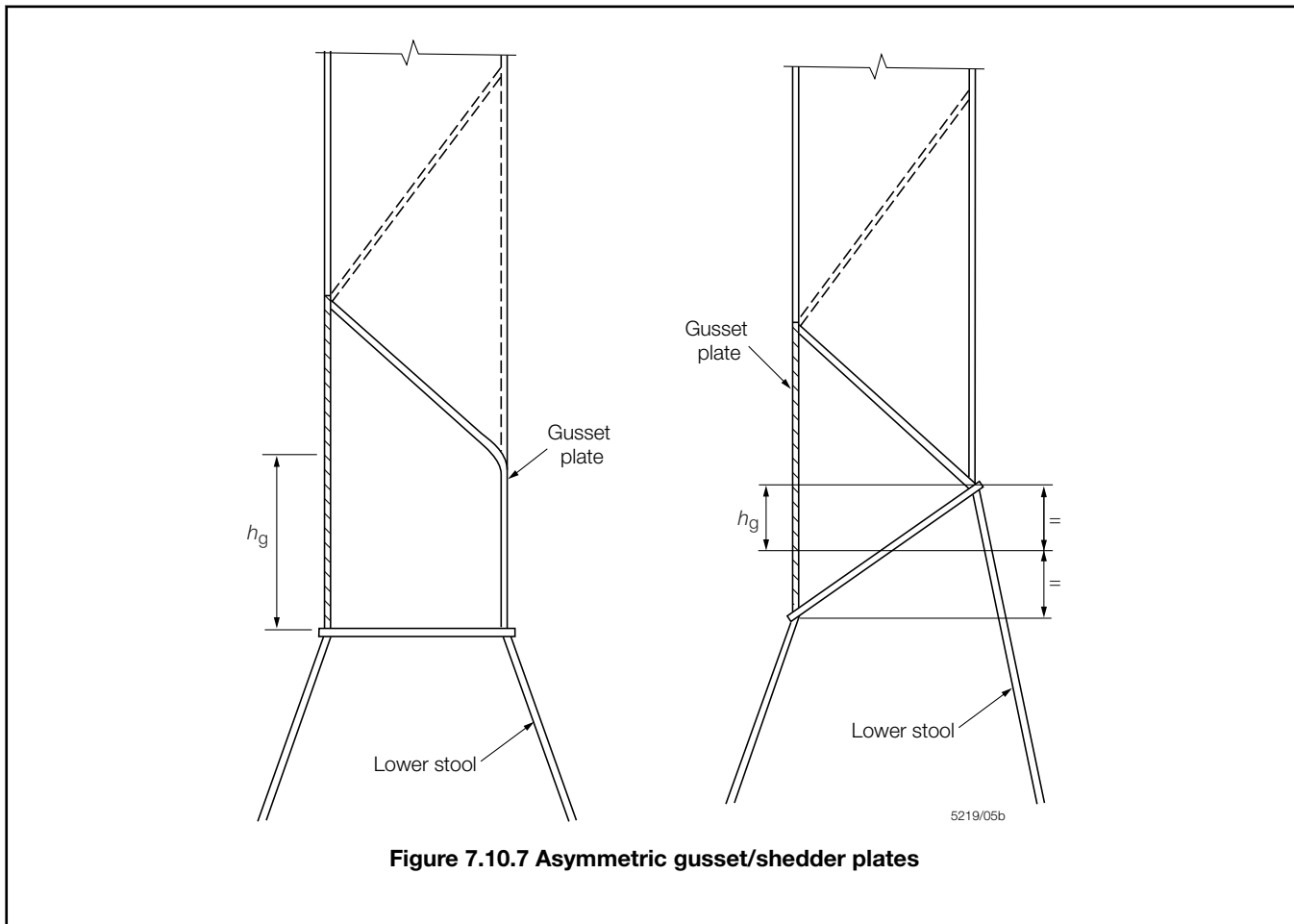

Figure 7.10.7 Asymmetric gusset/shedder plates

10.5.6 The applied shear stress, in N/mm^2 (kgf/mm^2), is determined by dividing the shear force derived from Pt 4, Ch 7, 10.5 Vertically corrugated transverse watertight bulkheads – Scantling assessment 10.5.2 by the shear area of the corrugation, calculated using the net plate thickness. The shear area is to be reduced to account for non-perpendicularity between the corrugation webs and flanges. In general, the reduced area may be obtained by multiplying the web sectional area by $\sin \phi$, where ϕ is the angle between the web and the flange, see Figure 7.10.2 Dimensions of bulkhead corrugation angles. The applied shear stress is not to exceed the permissible shear stress or the shear buckling stress given in Table 7.10.4 Permissible shear and buckling stresses.

Table 7.10.4 Permissible shear and buckling stresses

Bending, N/mm^2 (kgf/mm^2)	Shear, N/mm^2 (kgf/mm^2)	Shear buckling, N/mm^2 (kgf/mm^2)

$\sigma_p = \sigma_0$	$\tau_p = 0,5\sigma_0$	$\tau_{cr} = \tau_E$ when $\tau_E \leq \frac{\tau_0}{2}$ $= \tau_0 \left(1 - \frac{\tau_0}{4\tau_E}\right)$ when $\tau_E \leq \frac{\tau_0}{2}$
Symbols		
<p>b = width of corrugation flange, in metres, see <i>Figure 7.10.2 Dimensions of bulkhead corrugation angles</i></p> <p>c = width of corrugation web, in metres, see <i>Figure 7.10.2 Dimensions of bulkhead corrugation angles</i></p> <p>t_f = net flange plate thickness, in mm</p> <p>t_w = web plate net thickness, in mm</p> <p>E = modulus of elasticity = 206 000 N/mm² (21000 kgf/mm²)</p> <p>σ_0 = specified minimum yield stress, in N/mm² (kgf/mm²)</p> <p>$\tau_E = 5,706 E (t_w/1000c)^2$ N/mm² (kgf/mm²)</p> <p>$\tau_0 = \frac{\sigma_0}{\sqrt{3}}$ N/mm² (kgf/mm²)</p>		

10.5.7 The width of the compression flange, in metres, to be used for calculating the effective modulus is:

$$b_{ef} = C_{ef}b$$

where

$$= C_{ef} = \frac{2,25}{\beta} - \frac{1,25}{\beta^2} \quad \text{for } \beta > 1,25$$

$$C_{ef} = 1,0 \quad \text{for } \beta \leq 1,25$$

$$\beta = 10^3 \left(\frac{b}{t_f}\right) \sqrt{\frac{\sigma_0}{E}}$$

Other symbols are as defined in *Table 7.10.4 Permissible shear and buckling stresses*.

10.5.8 The corrugation flange and web local net plate thickness are not to be less than:

$$t = 14,9s_w \sqrt{1,05 \frac{p_r}{\sigma_0}} \text{ mm}$$

where

s_w = plate width, in metres, to be taken equal to the width of the corrugation flange or web, whichever is the greater

p_r = resultant pressure, in kN/m² (tonne-f/m²), as defined in *Table 7.10.3 Resultant pressure and force*, at the lower edge of each strake of plating. The net thickness of the lowest strake is to be determined using the resultant pressure at the top of the lower stool, (or at the inner bottom, if no lower stool is fitted), or at the top of the shedders, if effective shedder or gusset and shedder plates are fitted

σ_0 = specified minimum yield stress of the material, in N/mm² (kgf/mm²).

10.5.9 For built-up corrugations, where the thickness of the flange and of the web are different, the net thickness of the narrower plating is to be not less than:

$$t_n = 14,9s_n \sqrt{1,05 \frac{p_r}{\sigma_0}} \text{ mm}$$

where

s_n = width of the narrower plating, in metres.

The net thickness, in mm, of the wider plating is not to be taken less than the greater of:

$$t_{wp} = 14,9s_w \sqrt{1,05 \frac{p_r}{\sigma_0}} \text{ mm or}$$

$$t_{wp} = \sqrt{\frac{462s_w^2 p_r}{\sigma_0} - t_{np}^2} \text{ mm}$$

where

$t_{np} \leq$ actual net thickness of the narrower plating but not greater than:

$$14,9s_w \sqrt{1,05 \frac{p_r}{\sigma_0}} \text{ mm}$$

10.5.10 The required thickness of plating is the net thickness plus the corrosion addition given in *Pt 4, Ch 7, 10.4 Vertically corrugated transverse watertight bulkheads – Application and definitions 10.4.10*.

10.5.11 Scantlings required to meet the bending and shear strength requirements at the lower end of the bulkhead corrugation are to be maintained for a distance of $0,15l$ from the lower end, where l is as defined in *Pt 4, Ch 7, 10.5 Vertically corrugated transverse watertight bulkheads – Scantling assessment 10.5.1*. Scantlings required to meet the bending requirements at mid-height are to be maintained to a location no greater than $0,3l$ from the top of the corrugation. The section modulus of the remaining upper part of the corrugation is to be not less than $0,75$ times that required for the middle part, corrected for differences in yield stress.

10.6 Vertically corrugated transverse bulkheads – Support structure at ends

10.6.1 The requirements of *Pt 4, Ch 7, 10.2 Bulkheads supported by stools* are to be complied with as applicable, together with the following.

10.6.2 Lower stool:

- (a) The height of the lower stool is generally to be not less than three times the depth of the corrugations.
- (b) The thickness and steel grade of the stool shelf plate are to be not less than those required for the bulkhead plating above.
- (c) The thickness and steel grade of the upper portion of vertical or sloping stool side plating, within the depth equal to the corrugation flange width from the stool top, are to be not less than the flange plate thickness and steel grade needed to meet the bulkhead requirements at the lower end of the corrugation.
- (d) The thickness of the stool side plating and the section modulus of the stool side stiffeners are to be not less than those required by *Pt 4, Ch 1, 9 Bulkheads* for a plane transverse bulkhead and stiffeners using the greater of the pressures determined from the head, h_4 , in *Table 1.9.1 Watertight and deep tank bulkhead scantlings* and the expressions given in *Table 7.10.2 Bulkhead pressure and force*.
- (e) The ends of stool side vertical stiffeners are to be attached to brackets at the upper and lower ends of the stool.
- (f) The width of the shelf plate is to be in accordance with *Figure 7.10.8 Width of shelf plate*.
- (g) The stool bottom is to have a width not less than $2,5$ times the mean depth of the corrugation.
- (h) Scallops in the brackets and diaphragms in way of connections to the stool shelf plate are to be avoided.
- (i) Where corrugations are terminated on the bottom stool, corrugations are to be connected to the stool top plate by full penetration welds. The stool side plating is to be connected to the stool top plate and the inner bottom plating by either full penetration or partial penetration welds, see *Figure 7.10.9 Partial penetration welding*. The supporting floors are to be connected to the inner bottom by either full penetration or partial penetration welds.

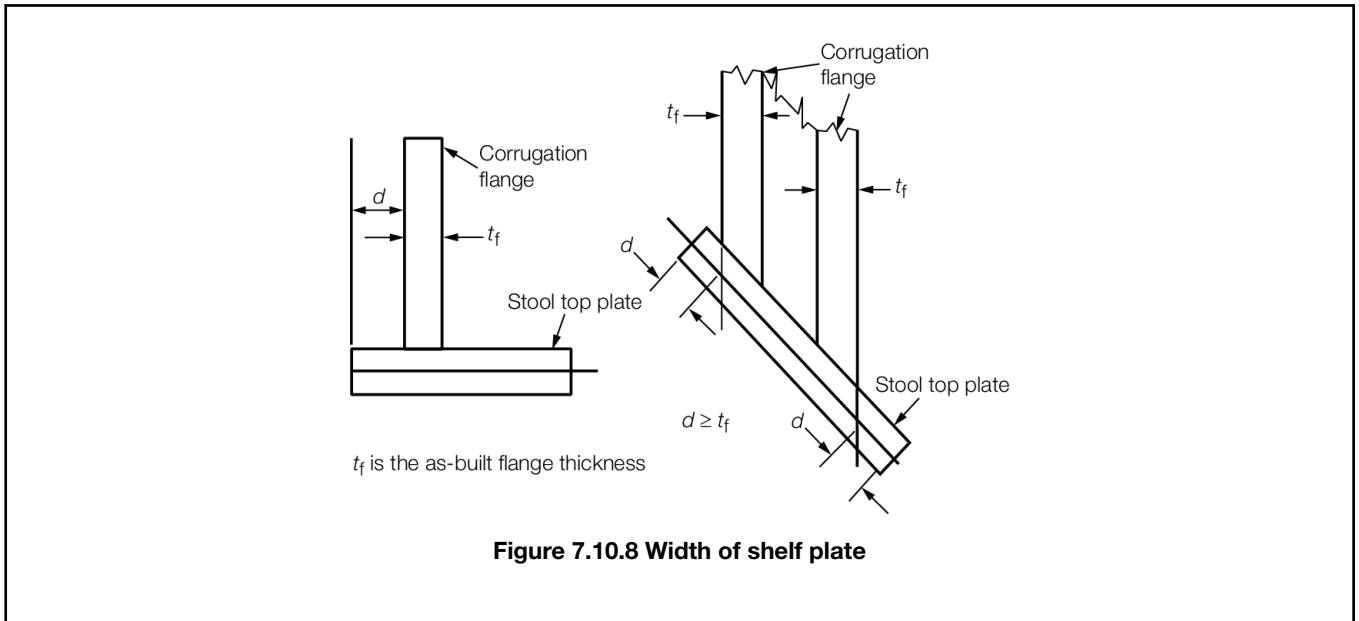

10.6.3 **Upper stool:**

- (a) The upper stool, where fitted, is to have a height generally between two and three times the depth of corrugations.
- (b) Rectangular stools are to have a height generally equal to twice the depth of corrugations, measured from the deck level and at hatch side girder.
- (c) The upper stool is to be properly supported by girders or deep brackets between the adjacent hatch-end beams.
- (d) The width of the shelf plate is generally to be the same as that of the lower stool shelf plate.
- (e) The upper end of a non-rectangular stool is to have a width not less than twice the depth of corrugations.
- (f) The thickness and steel grade of the shelf plate are to be the same as those of the bulkhead plating below.
- (g) The thickness of the lower portion of stool side plating is to be not less than 80 per cent of that required for the upper part of the bulkhead plating where the same materials are used.
- (h) The thickness of the stool side plating and the section modulus of the stool side stiffeners are to be not less than those required by Ch 1,9 for plane transverse bulkheads and stiffeners using the greater of the pressures determined from the head, h_4 , in *Table 1.9.1 Watertight and deep tank bulkhead scantlings* and the expressions given in *Table 7.10.2 Bulkhead pressure and force*.
- (i) Where vertical stiffening is fitted, the ends of stool side stiffeners are to be attached to brackets at the upper and lower end of the stool.
- (j) Diaphragms are to be fitted inside the stool, in line with, and effectively attached to, longitudinal deck girders extending to the hatch end coaming girders for effective support of the corrugated bulkhead.
- (k) Scallops in the brackets and diaphragms in way of the connection to the stool shelf plate are to be avoided.

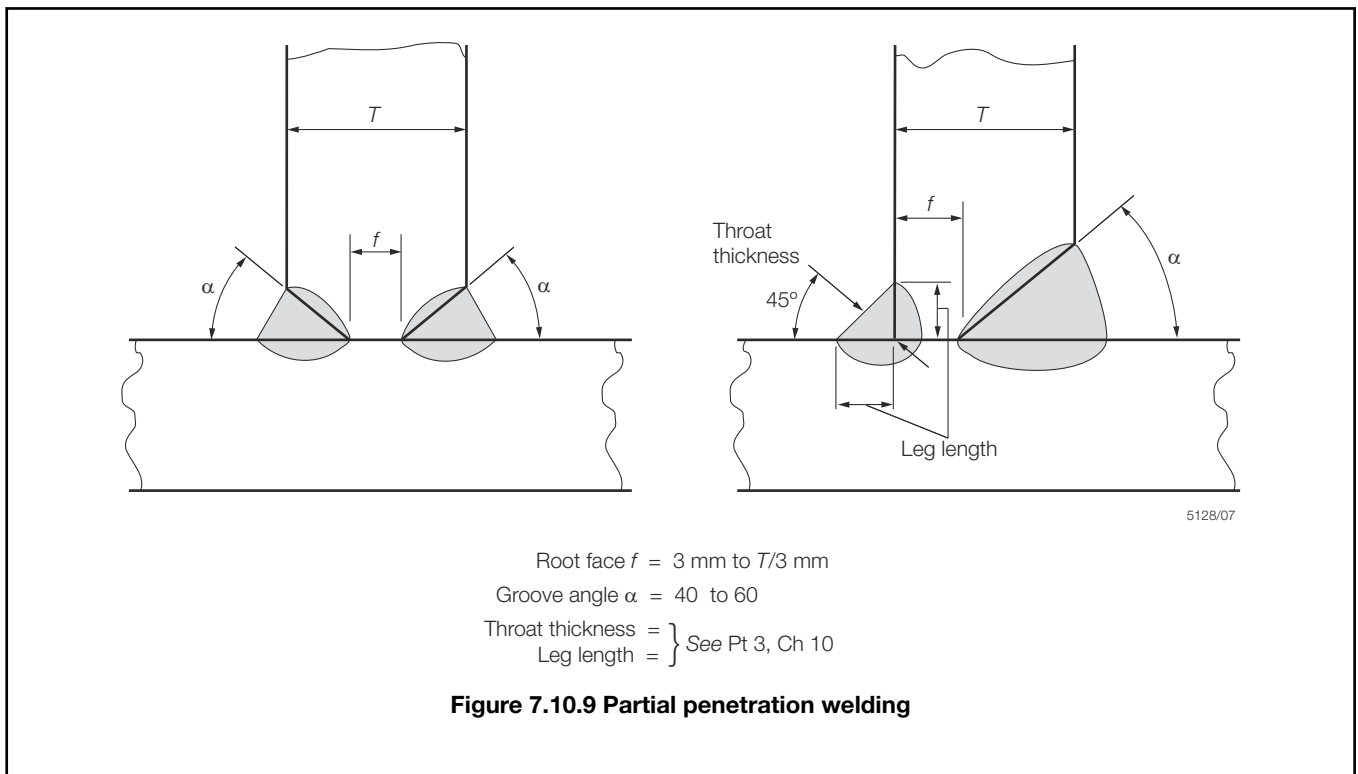

10.6.4 If no upper stool is fitted, two transverse reinforced beams are to be fitted in line with the corrugation flanges.

10.6.5 If no bottom stool is fitted, the corrugation flanges are to be in line with the supporting floors. Corrugations are to be connected to the inner bottom plating by full penetration welds. The thickness and steel grades of the supporting floors are to be at least equal to those provided for the corrugation flanges. The plating of supporting floors is to be connected to the inner bottom by either full penetration or deep penetration welds, see Figure 7.10.9 Partial penetration welding. The cut-outs for connections of the inner bottom longitudinals to double bottom floors are to be closed by collar plates. The supporting floors are to be connected to each other by suitably designed shear plates.

10.6.6 Stool side plating is to align with the corrugation flanges. Stool side vertical stiffeners and their brackets in the lower stool are to align with the inner bottom longitudinals to provide appropriate load transmission between these stiffening members. The lower stool side plating is not to be knuckled.

10.6.7 The design of local details is to take into account the transfer of the bulkhead forces and moments to the boundary structures and particularly to the double bottom and cross-deck structures.

■ **Section 11**
Direct calculation

11.1 Application

11.1.1 Direct calculations are to be employed in derivation of scantlings where required by the preceding Sections of this Chapter or by related provisions included in Pt 3 Ship Structures (General).

11.1.2 Direct calculation methods are also generally to be used where additional calculations are required by the Rules in respect of unusual structural arrangements.

11.2 Procedures

11.2.1 For details of LR's direct calculation procedures see Pt 3, Ch 1, 2 Direct calculations. For requirements concerning use of other calculation procedures, see Pt 3, Ch 1, 3 Equivalents.

■ **Section 12**
Steel hatch covers

12.1 General

12.1.1 These requirements apply to hatch covers on exposed decks in Position 1, see Pt 3, Ch 1, 6.5 Position 1 and Position 2 6.5.1, and are in addition to the following requirements:

- (a) Pt 3, Ch 11, 4.2 Steel covers – Clamped and gasketed 4.2.14, Pt 3, Ch 11, 4.2 Steel covers – Clamped and gasketed 4.2.16, Pt 3, Ch 11, 4.2 Steel covers – Clamped and gasketed 4.2.17, Pt 3, Ch 11, 4.2 Steel covers – Clamped and gasketed 4.2.25, Pt 3, Ch 11, 4.2 Steel covers – Clamped and gasketed 4.2.27, and Pt 3, Ch 11, 4.2 Steel covers – Clamped and gasketed 4.2.29.
- (b) Pt 3, Ch 11, 4.2 Steel covers – Clamped and gasketed 4.2.5 for the vertical weather pressure load case and cargo load, if carried on the hatch covers.

Note When cargo is carried on the hatch covers, Pt 3, Ch 11, 4.2 Steel covers – Clamped and gasketed 4.2.8 to Pt 3, Ch 11, 4.2 Steel covers – Clamped and gasketed 4.2.10 are also to be complied with. Cargo loads are to be in accordance with Pt 3, Ch 11, 2.3 Load model 2.3.4 and Pt 3, Ch 11, 2.3 Load model 2.3.5. Pt 4, Ch 8, 11.2 Direct calculations is to be considered for compliance with Pt 3, Ch 11, 2.4 Allowable stress and deflection 2.4.1, Pt 3, Ch 11, 2.4 Allowable stress and deflection 2.4.2, Pt 3, Ch 11, 2.5 Local net plate thickness 2.5.1, Pt 3, Ch 11, 2.8 Net scantling of secondary stiffeners 2.8.1, Pt 3, Ch 11, 2.8 Net scantling of secondary stiffeners 2.8.4, Pt 3, Ch 11, 2.8 Net scantling of secondary stiffeners 2.8.5, Pt 3, Ch 11, 2.9 Net scantling of primary supporting members 2.9.1 and Pt 3, Ch 11, 2.9 Net scantling of primary supporting members 2.9.2. The vertical weather design load needs not to be combined with the cargo load.

- (c) For hatch covers subject to wheel loading or helicopter landing, Pt 3, Ch 9, 3 Decks loaded by wheeled vehicles and Pt 3, Ch 9, 5 Helicopter landing areas are to be complied with.

12.1.2 The net plate thickness, t_{net} , is the calculated minimum thickness of the plating and stiffeners. The required thickness is the net thickness plus a corrosion addition, t_c , given in Table 7.12.1 Corrosion addition t_c .

Table 7.12.1 Corrosion addition t_c

Hatch cover type		t_c , in mm
(a)	Single skin	2,0
(b)	Pontoon (double skin)	
	(i) for the top and bottom plating	2,0
	(ii) for the internal structures	1,5

12.1.3 Material for the hatch covers is to be steel according to the requirements for ship's hull.

12.2 Stiffener arrangement

12.2.1 The secondary stiffeners and primary supporting members of the hatch covers are to be continuous over the breadth and length of the hatch covers, as far as practical. When this is impractical, sniped end connections are not to be used and appropriate arrangements are to be adopted to ensure sufficient load carrying capacity.

12.2.2 The spacing of primary supporting members parallel to the direction of secondary stiffeners is not to exceed $\frac{1}{3}$ of the span of primary supporting members.

12.3 Closing arrangements

12.3.1 Panel hatch covers are to be secured by appropriate devices (bolts, wedges or similar) suitably spaced alongside the coamings and between cover elements.

12.3.2 Arrangement and spacing are to be determined with due attention to the effectiveness for weather-tightness, depending upon the type and the size of the hatch cover, as well as on the stiffness of the cover edges between the securing devices.

12.3.3 The net sectional area of each securing device is not to be less than:

$$A = 1,4 a/f \text{ cm}^2$$

where

a = spacing in m of securing devices, not being taken less than 2 m

$$f = (\sigma_Y/235)^e$$

σ_Y = specified minimum upper yield stress in N/mm² of the steel used for fabrication, not to be taken greater than 70 per cent of the ultimate tensile strength

$$e = 0,75 \text{ for } \sigma_Y > 235$$

$$= 1,0 \text{ for } \sigma_Y \leq 235$$

12.3.4 Rods or bolts are to have a net diameter not less than 19 mm for hatchways exceeding 5 m² in area.

12.3.5 Between cover and coaming and at cross-joints, a packing line force sufficient to obtain weathertightness is to be maintained by the securing devices. For packing line forces exceeding 5 N/mm, the cross section area is to be increased in direct proportion. The packing line force is to be specified.

12.3.6 The cover edge stiffness is to be sufficient to maintain adequate sealing pressure between securing devices. The moment of inertia, I , of edge elements is not to be less than:

$$I = 6\rho a^4 \text{ cm}^4$$

where

ρ = packing line pressure in N/mm, minimum 5 N/mm

a = spacing in m of securing devices.

12.3.7 Securing devices are to be of reliable construction and securely attached to the hatchway coamings, decks or covers. Individual securing devices on each cover are to have approximately the same stiffness characteristics.

12.3.8 Where rod cleats are fitted, resilient washers or cushions are to be incorporated.

12.3.9 Where hydraulic cleating is adopted, a positive means is to be provided to ensure that it remains mechanically locked in the closed position in the event of failure of the hydraulic system.

12.3.10 Hatch covers are to be effectively secured, by means of stoppers, against transverse and longitudinal forces (acting on the forward end) arising from a pressure of 175 kN/m².

12.3.11 The equivalent stress:

- in stoppers and their supporting structures; and
- calculated in the throat of the stopper welds; is not to exceed the allowable value of $0,8\sigma_Y$.

12.4 Load model

12.4.1 The pressure, p , in kN/m², acting on the hatch covers is given by:

- (a) For ships of length 100 m or greater, for hatchways located on the freeboard deck, p is to be the greater of 34,3 or the following:

$$p = 34,3 + \frac{p_{FP} - 34,3}{0,25} \left(0,25 - \frac{x}{L}\right)$$

Where a hatchway is located in position 1 and at least one superstructure standard height higher than the freeboard deck, the pressure p may be 34,3 kN/m².

- (b) For ships less than 100 m in length, for hatchways located at the freeboard deck, p is to be the greater of $0,195L + 14,9$ or the following:

$$p = 15,8 + \frac{L}{3} \left(1 - \frac{5}{3} \frac{x}{L}\right) - 3,6 \frac{x}{L}$$

Where two or more panels are connected by hinges, each individual panel is to be considered separately.

where

p_{FP} = pressure at the forward perpendicular

$$= 49,1 + (L - 100) a$$

a = 0,0726 for type B freeboard ships

= 0,356 for ships with reduced freeboard

L = Freeboard length, in metres, as defined in *Regulation 3 - Definitions of terms used in the Annexes of Annex I to the 1966 Load Line Convention as modified by the Protocol of 1988*, to be taken not greater than 340 m

x = distance, in metres, of the mid length of the hatch cover under examination from the forward end of L .

- (c) For weather deck covers for holds which may be flooded and used as ballast tanks and holds in OBO, ore or oil and similar types of ship, the pressure p , in kN/m², due to the internal load for a member and position under consideration is to be taken as:

$$p = 5,53Y \sin q \text{ kN/m}^2$$

where

$$\sin q = \left(0,45 + \frac{L}{10B} \right) \left(0,54 - \frac{L}{1270} \right)$$

q = roll angle, in degrees, but need not exceed 25° and is not to be taken as less than 22°

Y = transverse distance, in metres, from the side coaming at the coaming top to the member and position under consideration. Both sides of roll are to be considered.

In way of holds for oil cargo, a load equivalent to the inert gas pressure is to be applied over the full breadth of the cover and added to the load corresponding to the liquid pressure. However, where the rolling angle has been determined by direct calculations, the load may be derived accordingly.

12.5 Allowable stress

12.5.1 The normal and shear stresses calculated for the net section hatch cover structures are not to exceed the values given in *Table 7.12.2 Permissible stresses*.

Table 7.12.2 Permissible stresses

Failure mode	Permissible stress, in N/mm ² (kgf/mm ²)	
Bending	σ_a	= 0,80 σ_F
Shear	τ_a	= 0,46 σ_F
Symbols		
σ_F = minimum upper yield stress, in N/mm ² (kgf/mm ²)		

12.5.2 The normal stress in compression of the attached flange of primary supporting members is not to exceed 0,8 times the critical buckling stress of the structure according to the buckling check as given in *Pt 4, Ch 7, 12.10 Hatch cover plating, Pt 4, Ch 7, 12.11 Hatch cover secondary stiffeners and Pt 4, Ch 7, 12.12 Web panels of hatch cover primary supporting members*.

12.5.3 The stresses in hatch covers that are designed as a grillage of longitudinal and transverse primary supporting members are to be determined by a grillage or a FE analysis. When such an analysis is used the secondary stiffeners are not to be included in the attached flange area of the primary members.

12.5.4 When calculating the stresses σ and τ as defined in *Table 7.12.2 Permissible stresses*, the net scantlings are to be used.

12.6 Effective cross-sectional area of panel flanges for primary supporting members

12.6.1 The effective flange area, A_f , in cm^2 , of the attached plating, to be considered for the yielding and buckling checks of primary supporting members, when calculated by means of a beam or grillage model, is obtained as the sum of the effective flange areas of each side of the girder web as appropriate:

$$A_f = \sum_{nf} (10b_{ef}t)$$

where

nf = 2 if attached plate flange extends on both sides of girder web

= 1 if attached plate flange extends on one side of girder web only

t = net thickness of considered attached plate, in mm

b_{ef} = effective breadth of attached plate flange on each side of girder web, in metres

= b_p , but not to be taken greater than $0,165l$

b_p = half distance between the considered primary supporting member and the adjacent one, in metres

l = span of primary supporting members, in metres.

12.7 Local net plate thickness

12.7.1 The local net plate thickness of the hatch cover top plating is to be not less than:

$$t = F_p 15,8s \sqrt{\frac{p}{0,95 \sigma_F}}$$

or 1 per cent of the spacing of the stiffeners or 6 mm, whichever is greater

where

F_p = factor for combined membrane and bending response

= 1,50 in general

= $1,90\sigma/\sigma_a$, where $\sigma/\sigma_a \geq 0,8$, for the attached plate flange of primary supporting members

s = stiffener spacing, in metres

p = pressure, in kN/m^2 , as defined in *Pt 4, Ch 7, 12.4 Load model*

σ = as defined in *Pt 4, Ch 7, 12.9 Net scantlings of primary supporting members*

σ_a = as defined in *Pt 4, Ch 7, 12.5 Allowable stress*.

12.7.2 For double skin hatch covers, when the lower plating is taken into account as a strength member of the hatch cover, the local net plate thickness of the hatch cover bottom plating is to be not less than:

$$t = 6,5s \text{ mm, or}$$

$$t = 5,0 \text{ mm, whichever is the greater}$$

where

s = stiffener spacing, in metres.

12.8 Net scantlings of secondary stiffeners

12.8.1 The required minimum section modulus, Z , in cm^3 , of secondary stiffeners of the hatch cover top plate, based on stiffener net member thickness, is given by:

$$Z = \frac{1000l^2 s p}{12 \sigma_a}$$

where

l = secondary stiffener span, in metres, to be taken as the spacing, in metres, of primary supporting members or the distance between a primary supporting member and the edge support, as applicable. When brackets are fitted at both ends of all secondary stiffener spans, the secondary stiffener span may be reduced by an amount equal to $\frac{2}{3}$ of the minimum bracket arm length, but not greater than 10 per cent of the gross span, for each bracket

s = secondary stiffener spacing, in metres

p = pressure, in kN/m², as defined in Pt 4, Ch 7, 12.4 Load model

σ_a = as defined in Pt 4, Ch 7, 12.5 Allowable stress.

12.8.2 The net section modulus of the secondary stiffeners is to be determined based on an attached plate width assumed equal to the stiffener spacing.

12.9 Net scantlings of primary supporting members

12.9.1 The section modulus and web thickness of primary supporting members, based on member net thickness, are to be such that the normal stress σ in both flanges and the shear stress τ , in the web, do not exceed the allowable values σ_a and τ_a , respectively, defined in Pt 4, Ch 7, 12.5 Allowable stress.

12.9.2 The breadth of the primary supporting member flange is to be not less than 40 per cent of their depth for laterally unsupported spans greater than 3,0 m. Tripping brackets attached to the flange may be considered as a lateral support for primary supporting members.

12.9.3 The flange outstand is not to exceed 15 times the flange thickness.

12.10 Hatch cover plating

12.10.1 The compressive stress, σ , in N/mm², in the hatch cover plate panels, induced by the bending of primary supporting members parallel to the direction of secondary stiffeners, is not to exceed 0,8 times the critical buckling stress σ_{C1} , to be evaluated as defined below:

$$\begin{aligned} \sigma_{C1} &= \sigma_{E1} && \text{when } \sigma_{E1} \leq \sigma_F/2 \\ &= \sigma_F [1 - \sigma_F/(4\sigma_{E1})] && \text{when } \sigma_{E1} > \sigma_F/2 \end{aligned}$$

where

σ_F = minimum upper yield stress, in N/mm², of the material

$$\sigma_{E1} = 3,6 E \left(\frac{t}{1000_s} \right)^2$$

E = modulus of elasticity, in N/mm²

= 2,06 x 10⁵ for steel

t = net thickness, in mm, of plate panel

s = spacing of secondary stiffeners, in metres

12.10.2 The mean compressive stress σ in each of the hatch cover plate panels, induced by the bending of primary supporting members perpendicular to the direction of secondary stiffeners, is not to exceed 0,8 times the critical buckling stress σ_{C2} , to be evaluated as defined below:

$$\begin{aligned} \sigma_{C2} &= \sigma_{E2} && \text{when } \sigma_{E2} \leq \sigma_F/2 \\ &= \sigma_F [1 - \sigma_F/(4\sigma_{E2})] && \text{when } \sigma_{E2} > \sigma_F/2 \end{aligned}$$

where

σ_F = minimum upper yield stress, in N/mm², of the material

$$\sigma_{E2} = 0,9m E \left(\frac{t}{1000s_s} \right)^2$$

$$m = c \left[1 + \left(\frac{s_s}{l_s} \right)^2 \right]^2 \frac{2,1}{\psi + 1,1}$$

E = modulus of elasticity, in N/mm²

= 2,06 x 10⁵ for steel

t = net thickness of plate panel, in mm

s_s = length of the shorter side of the plate panel, in metres

l_s = length of the longer side of the plate panel, in metres

Ψ = ratio between smallest and largest compressive stress

c = 1,3 when plating is stiffened by primary supporting members

= 1,21 when plating is stiffened by secondary stiffeners of angle or T type

= 1,1 when plating is stiffened by secondary stiffeners of bulb type

= 1,05 when plating is stiffened by flat bar.

12.10.3 The biaxial compressive stress in the hatch cover panels, when calculated by means of FEM shell element model, is to comply with Pt 3, Ch 11, 2.11 *Buckling strength of hatch cover structures 2.11.2*, using $S = 1,25$.

12.11 Hatch cover secondary stiffeners

12.11.1 The compressive stress σ , in N/mm², in the top flange of secondary stiffeners, induced by the bending of primary supporting members parallel to the direction of secondary stiffeners, is not to exceed 0,8 times the critical buckling stress σ_{CS} , to be evaluated as defined below:

$$\begin{aligned} \sigma_{CS} &= \sigma_{ES} && \text{when } \sigma_{ES} \leq \sigma_F/2 \\ &= \sigma_F [1 - \sigma_F/(4\sigma_{ES})] && \text{when } \sigma_{ES} > \sigma_F/2 \end{aligned}$$

where

σ_F = minimum upper yield stress, in N/mm², of the material

σ_{ES} = ideal elastic buckling stress, in N/mm², of the secondary stiffener

= minimum between σ_{E3} and σ_{E4}

$$\sigma_{E3} = 0,001E I_a/(A l^2)$$

E = modulus of elasticity, in N/mm²

= 2,06 x 10⁵ for steel

I_a = moment of inertia of the secondary stiffener, including a top flange equal to the spacing of secondary stiffeners, in cm⁴

A = cross-sectional area of the secondary stiffener, including a top flange equal to the spacing of secondary stiffeners, in cm²

l = span of the secondary stiffener, in metres

$$\sigma_{E4} = \frac{\pi^2 E I_w}{10^4 I_p l^2} \left(m^2 + \frac{K}{m^2} \right) + 0,385 E \frac{I_t}{I_p}$$

where

$$K = \frac{C l^4}{\pi^4 E I_w} 10^6 \quad m$$

m = number of half waves, given in *Table 7.12.3 Number of half waves*

I_w = sectorial moment of inertia (warping constant) of the secondary stiffener about its connection with the plating, in cm^6

$$= \frac{h_w^3 t_w^3}{36} 10^{-6} \text{ for flat bar secondary stiffeners}$$

$$= \frac{t_f b_f^3 h_w^2}{12} 10^{-6} \text{ 'Tee' secondary stiffeners}$$

$$= \frac{b_f h_w^2}{12(b_f + h_w)^2} [t_f(b_f^2 + 2b_f h_w + 4h_w^2) + 3t_w b_f h_w] 10^{-6}$$

= for angles and bulb secondary stiffeners

I_p = polar moment of inertia of the secondary stiffener about its connection with the plating, in cm^4

$$= \frac{h_w^3 t_w}{3} 10^{-4} \text{ for flat bar secondary stiffeners}$$

$$= \left(\frac{h_w^3 t_w}{3} + h_w^2 b_f t_f \right) 10^{-4}$$

= for flanged secondary stiffeners

I_t = St.Venant's moment of inertia of the secondary stiffener without top flange, in cm^4

$$= \frac{h_w^3 t_w}{3} 10^{-4} \text{ for flat secondary stiffeners}$$

$$= \frac{1}{3} \left[h_w t_w^3 + b_f t_f^3 \left(1 - 0,63 \frac{t_f}{b_f} \right) \right] 10^{-4}$$

= for flanged secondary stiffeners

h_w, t_w = height and net thickness of the secondary stiffener, respectively, in mm

b_f, t_f = width and net thickness of the secondary stiffener bottom flange, respectively, in mm

s = spacing of secondary stiffeners, in metres

C = spring stiffness exerted by the hatch cover top plating

$$= \frac{k_p E t_p^3}{3s \left[1 + \frac{1,33k_p h_w t_p^3}{1000s^3} \right]} 10^{-3}$$

k_p = $1 - \eta_p$ to be taken not less than zero; for flanged secondary stiffeners, k_p need not be taken less than 0,1

$$\eta_p = \frac{\sigma}{\sigma_{E1}}$$

σ = as defined in *Pt 4, Ch 7, 12.9 Net scantlings of primary supporting members*

σ_{E1} = as defined in *Pt 4, Ch 7, 12.10 Hatch cover plating*

where

t_p = net thickness of the hatch cover plate panel, in mm.

Table 7.12.3 Number of half waves

K	m
$0 < K < 4$	1
$4 < K < 36$	2
$36 < K < 144$	3
$(m - 1)^2 m^2 < K \leq m^2 (m + 1)^2$	m

12.11.2 For flat bar secondary stiffeners and buckling stiffeners, the ratio h/t_w is to be not greater than $15k^{0,5}$

where

h, t_w = height and net thickness of the stiffener, respectively

$$k = 235/\sigma_F$$

σ_F = minimum upper yield stress, in N/mm², of the material.

12.12 Web panels of hatch cover primary supporting members

12.12.1 This check is to be carried out for the web panels of primary supporting members formed by web stiffeners or by the crossing with other primary supporting members, the face plate (or the bottom cover plate) or the attached top cover plate.

12.12.2 The shear stress τ in the hatch cover primary supporting members web panels is not to exceed 0,8 times the critical buckling stress τ_C , to be evaluated as defined below:

$$\begin{aligned} \tau_C &= \tau_E && \text{when } \tau_E \leq \tau_F/2 \\ &= \tau_F [1 - \tau_F/(4\tau_E)] && \text{when } \tau_E > \tau_F/2 \end{aligned}$$

where

σ_F = minimum upper yield stress of the material, in N/mm²

$$\tau_F = \frac{\sigma_F}{\sqrt{3}}$$

$$\tau_E = 0,9k_t E \left(\frac{t_{pr,n}}{1000d} \right)^2$$

E = modulus of elasticity, in N/mm²
= 2,06 x 10⁵ for steel

$t_{pr,n}$ = net thickness of primary supporting member, in mm

$$k_t = 5,35 + 4,0/(a/d)^2$$

a = greater dimension of web panel of primary supporting member, in metres

d = smaller dimension of web panel of primary supporting member, in metres.

12.12.3 For primary supporting members parallel to the direction of secondary stiffeners, the actual dimensions of the panels are to be considered.

12.12.4 For primary supporting members perpendicular to the direction of secondary stiffeners or for hatch covers built without secondary stiffeners, a presumed square panel of dimension d is to be taken for the determination of the stress τ_C . In such a case, the average shear stress τ between the values calculated at the ends of this panel is to be considered.

12.13 Deflection limit and connections between hatch cover panel

12.13.1 Load bearing connections between the hatch cover panels are to be fitted with the purpose of restricting the relative vertical displacements.

12.13.2 The vertical deflection of primary supporting members is to be not more than $0,0056l$, where l is the greatest span of primary supporting members.

■ *Section 13*
Hatch coamings

13.1 General

13.1.1 The height and construction of forward and side hatch coamings are to comply with the following requirements. All hatch coamings are to comply with the requirements of *Pt 3, Ch 11, 5.1 General 5.1.1, Pt 3, Ch 11, 5.1 General 5.1.3, Pt 3, Ch 11, 5.2 Construction 5.2.1, Pt 3, Ch 11, 5.2 Construction 5.2.2, Pt 3, Ch 11, 5.2 Construction 5.2.4 to Pt 3, Ch 11, 5.2 Construction 5.2.12, Pt 3, Ch 11, 5.2 Construction 5.2.16 to Pt 3, Ch 11, 5.2 Construction 5.2.18 and Pt 3, Ch 11, 5.4 Rest bars in hatchways 5.4.1.*

13.1.2 For the structure of hatch coamings and coaming stays, the corrosion addition t_c is to be 1,5 mm.

13.1.3 Material for the hatch coamings is to be steel according to the requirements for the ship's hull.

13.1.4 The secondary stiffeners of the hatch coamings are to be continuous over the breadth and length of the hatch coamings.

13.2 Load model

13.2.1 The pressure p_{coam} , on hatch coamings is to be taken as 220 kN/m².

13.3 Local net plate thickness

13.3.1 The local net plate thickness, t , in mm, of the hatch coaming plating is to be the greater of 9,5 mm or the following:

$$t = 14,9s \sqrt{\frac{p_{\text{coam}}}{\sigma_{\text{a,coam}}}} S_{\text{coam}}$$

where

s = secondary stiffener spacing, in metres

P_{coam} = pressure, in kN/m², as defined in *Pt 4, Ch 7, 13.2 Load model 13.2.1*

S_{coam} = safety factor to be taken equal to 1,15

$\sigma_{\text{a,coam}}$ = $0,95\sigma_F$.

σ_F = minimum upper yield stress, in N/mm², of the material.

13.4 Net scantlings of longitudinal and transverse secondary stiffeners

13.4.1 The required section modulus, Z , in cm³, of the longitudinal or transverse secondary stiffeners of the hatch coamings, based on net member thickness, is given by:

$$Z = \frac{1000S_{\text{coam}} l^2 s p_{\text{coam}}}{m c_p \sigma_{\text{a,coam}}}$$

where

m = 16 in general

= 12 for the end spans of stiffeners sniped at the coaming corners

where

S_{coam} = safety factor to be taken equal to 1,15

l = span of secondary stiffeners, in metres

s = spacing of secondary stiffeners, in metres

p_{coam} = pressure in kN/m² as defined in *Pt 4, Ch 7, 13.2 Load model 13.2.1*

C_p = ratio of the plastic section modulus to the elastic section modulus of the secondary stiffeners with an attached plate breadth equal to 40t, where t is the plate net thickness, in mm

= 1,16 in the absence of more precise evaluation

$\sigma_{\text{a,coam}}$ = 0,95 σ_F

σ_F = minimum upper yield stress, in N/mm², of the material.

13.5 Net scantlings of coaming stays

13.5.1 The required minimum section modulus, Z , in cm³, and web thickness, t_w , in mm of coaming stays designed as beams with flange connected to the deck or sniped and fitted with a bracket (see *Figure 7.13.1 Typical coaming stays, Type A and B*) at their connection with the deck, based on member net thickness, are given by:

$$Z = \frac{1000H_c^2 s p_{\text{coam}}}{2 \sigma_{\text{a,coam}}}$$

$$t_w = \frac{1000H_c s p_{\text{coam}}}{h \tau_{\text{a,coam}}}$$

where

H_C = stay height, in metres

s = stay spacing, in metres

h = stay depth at the connection with the deck, in mm

p_{coam} = pressure, in kN/m², as defined in *Pt 4, Ch 7, 13.2 Load model 13.2.1*

$\sigma_{\text{a,coam}}$ = 0,95 σ_F

$t_{\text{a,coam}}$ = 0,5 σ_F

σ_F = minimum upper yield stress, in N/mm², of the material.

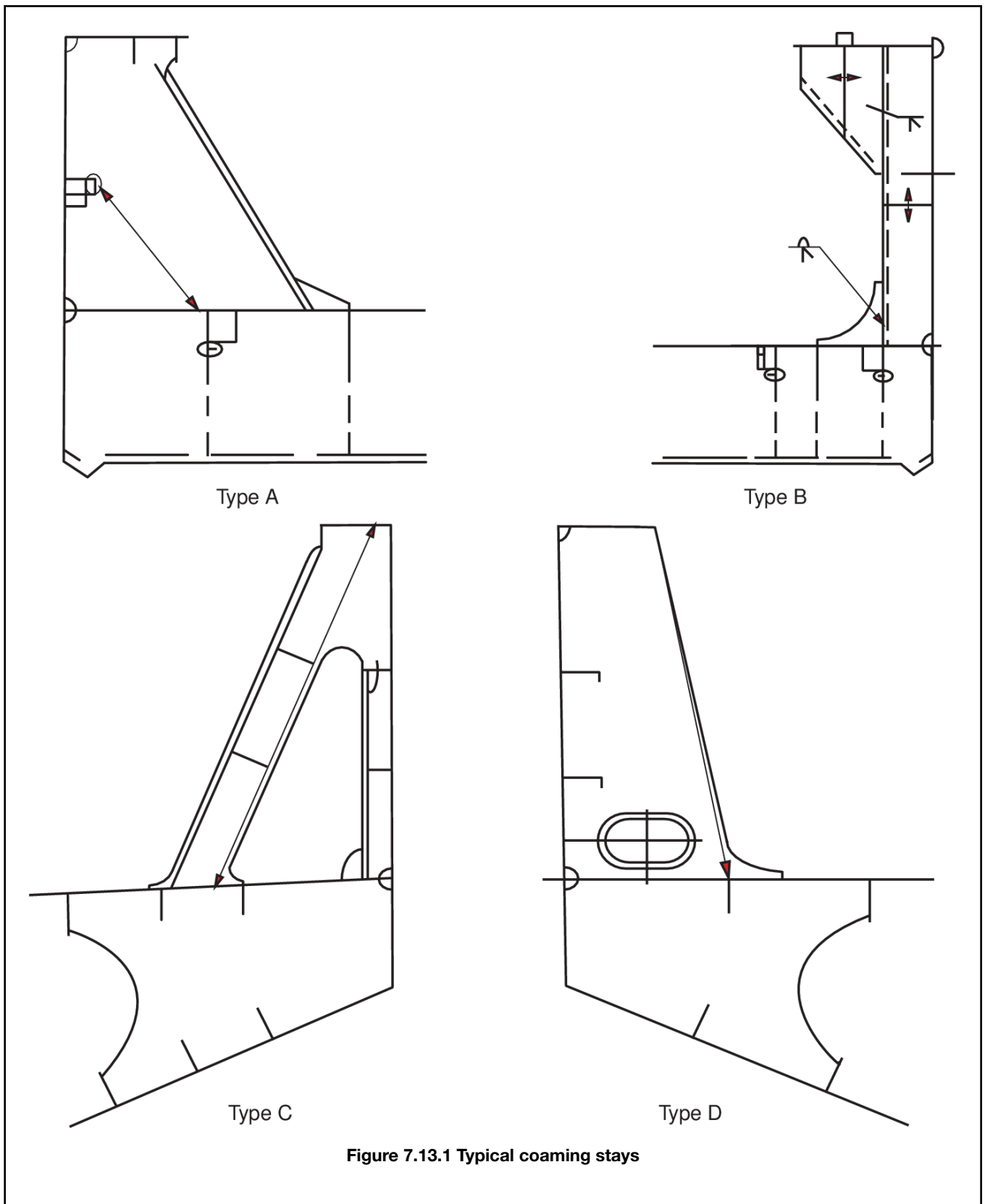

13.5.2 For calculating the section modulus of coaming stays, their face plate area is to be taken into account only when it is welded with full penetration welds to the deck plating and adequate underdeck structure is fitted to support the stresses transmitted by it.

13.5.3 For other designs of coaming stays, such as those shown in *Figure 7.13.1 Typical coaming stays Type C and D*, the stress levels in 12.5 apply and are to be checked at the highest stressed locations.

13.6 Local details

13.6.1 The design of local details is to comply with *Pt 3, Ch 11, 5 Hatch coamings* for the purpose of transferring the pressures on the hatch covers to the hatch coamings and, through them, to the deck structures below. Hatch coamings and supporting structures are to be adequately stiffened to accommodate the loading from hatch covers, in longitudinal, transverse and vertical directions.

13.6.2 Underdeck structures are to be checked against the load transmitted by the stays, adopting the same allowable stresses specified in *Pt 4, Ch 7, 13.5 Net scantlings of coaming stays 13.5.1*.

13.6.3 Double continuous welding is to be adopted for the connections of stay webs with deck plating and the weld throat is to be not less than $0,44t_w$, where t_w is the gross thickness of the stay web.

13.6.4 Toes of stay webs are to be connected to the deck plating with deep penetration double bevel welds extending over a distance not less than 15 per cent of the stay width.

■ **Section 14
Forecastles**

14.1 Arrangement

14.1.1 An enclosed forecastle is to be fitted on the freeboard deck.

14.1.2 The aft bulkhead of the forecastle is to be fitted in way or aft of the forward bulkhead in the foremost cargo hold. See *Figure 7.14.1 Forecastle arrangement*. However, if this requirement hinders hatch cover operation, the aft bulkhead of the forecastle may be fitted forward of the forward bulkhead of the foremost cargo hold provided the forecastle length is not less than 7 per cent of ship length abaft the forward perpendicular where the ship length and forward perpendicular are defined in the *International Convention on Load Lines 1966* and its Protocol of 1988.

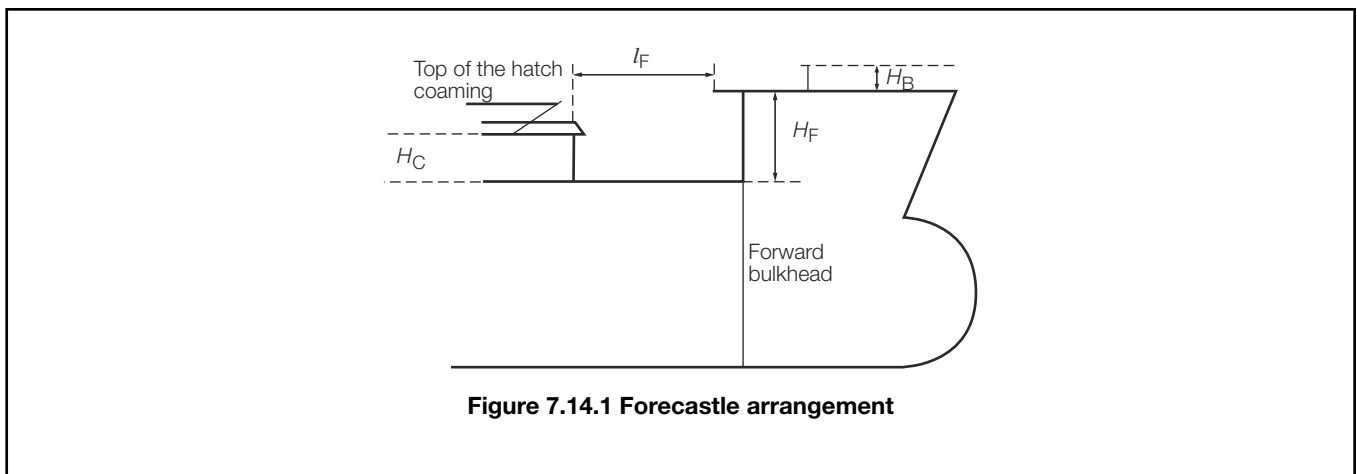

Figure 7.14.1 Forecastle arrangement

14.1.3 The forecastle height H_F , in metres, above the main deck is to be not less than the greater of:

- the standard height of a superstructure as specified in the *Load Lines, 1966/1988 - International Convention on Load Lines, 1966, as Amended by the Protocol of 1988* ; or
- $H_C + 0,5$ m

where

H_C = the height, in metres, of the forward transverse hatch coaming of cargo hold No.1.

14.1.4 All points of the aft edge of the forecastle deck are to be located at a distance:

$$l_f < 5\sqrt{(H_F - H_C)}$$

from the hatch coaming, see *Figure 7.14.1 Forecastle arrangement*.

14.1.5 A breakwater is not to be fitted on the forecastle deck with the purpose of protecting the hatch coaming or hatch covers. If fitted for other purposes, it is to be located such that its upper edge at centre line is not less than:

$$H_B / \tan 20^\circ$$

forward of the aft edge of the forecastle deck.

where

H_B = the height, in metres, of the breakwater above the forecastle, see *Figure 7.14.1 Forecastle arrangement*.

14.2 Construction

14.2.1 The construction of the forecastle is to comply with the requirements of *Pt 3, Ch 8, 4 Forecastles*.

Section

- 1 **General**
- 2 **Materials**
- 3 **Longitudinal strength**
- 4 **Deck structure**
- 5 **Shell envelope plating**
- 6 **Shell envelope framing**
- 7 **Double bottom structure**
- 8 **Longitudinal bulkheads**
- 9 **Transverse bulkheads**
- 10 **Hatch coamings and support for hatch covers**
- 11 **Hatch covers**
- 12 **Strengthening for wave impact loads**
- 13 **Container stowage systems**
- 14 **Direct calculation**
- 15 **Requirements for ships with large deck openings**

■ *Section 1*
General

1.1 Application and definitions

1.1.1 A **container ship** is defined as a ship designed exclusively for the carriage of containers in holds and on deck. Containers in holds are normally stowed within cellular guide systems.

1.1.2 The term 'narrow side structures' applies where the breadth of hatch opening exceeds 90 per cent of the breadth of the ship.

1.1.3 Other terms used to describe the various structural components of container ships are generally indicated in Lloyd's Register's (hereinafter referred to as 'LR') ShipRight FDA Procedure, *Structural Detail Design Guide*.

1.1.4 Scantlings and arrangements of container ships are to be as required by *Pt 4, Ch 1 General Cargo Ships*, except as otherwise indicated in this Chapter.

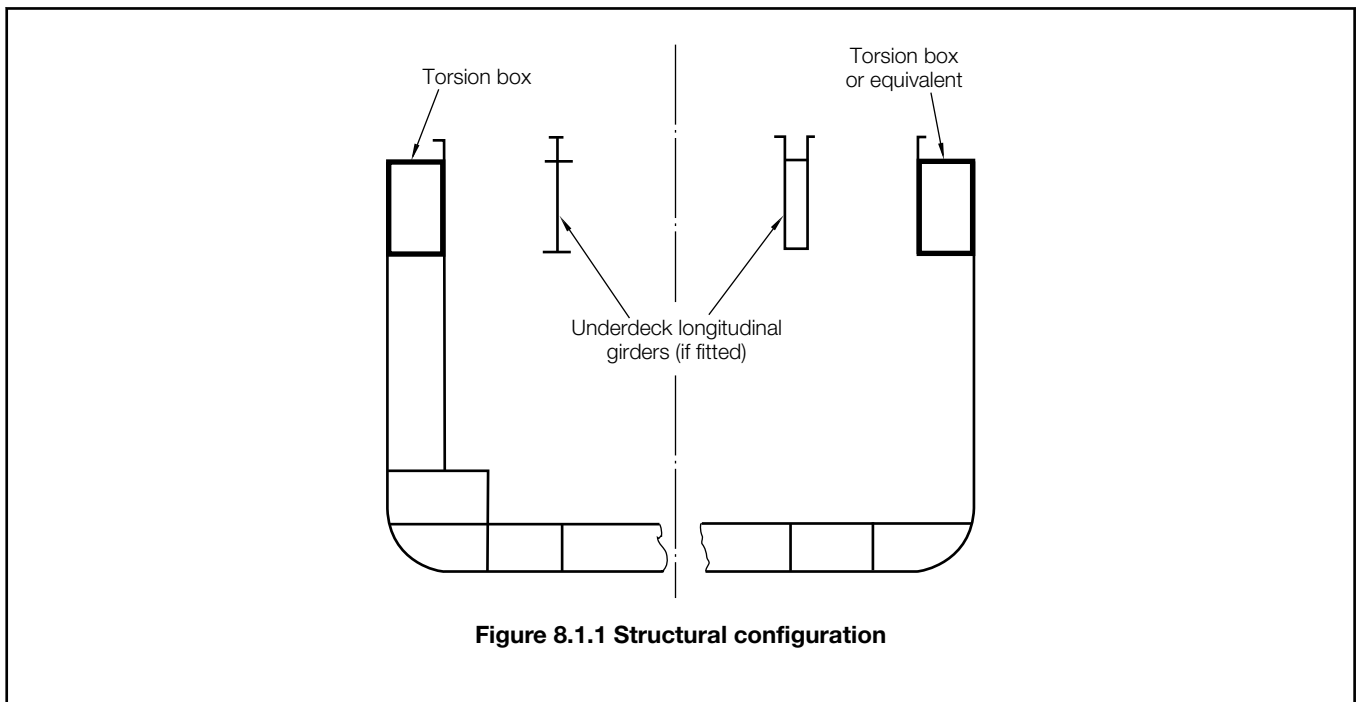

1.2 Structural configuration

1.2.1 *Figure 8.1.1 Structural configuration* shows the typical structural configuration of a container ship covered by the requirements of this Chapter. The typical configuration includes:

- (a) An efficient torsion box girder or equivalent structure at the topsides comprising strength deck, side shell, inner skin and a second deck. The space within the torsion box is often utilised as an underdeck access passageway.
- (b) Single or double skin side construction with or without bilge box.
- (c) Double bottom.
- (d) Continuous or discontinuous hatch coamings.
- (e) Optional continuous deck girders to support hatch covers.

1.2.2 For container ships which do not conform to the above configuration, the application of this Chapter will be specially considered

1.3 Class notations

1.3.1 In general, ships complying with the requirements of this Chapter will be eligible to be classed **100A1 Container Ship**.

1.3.2 LR 'ShipRight Procedures' for the hull construction of ships are detailed in *Pt 3, Ch 16 ShipRight Procedures for the Design, Construction and Lifetime Care of Ships* and the associated notations and descriptive notes are given in *Pt 1, Ch 2, 2.2 Character symbols*.

1.3.3 The ShipRight notation **SDA** (Structural Design Assessment) and subsequently **CM** (Construction Monitoring) are mandatory for container ships with a beam greater than 32 m or where the type, size and structural configuration demand, including container ships with narrow side structures, abnormal hull form or unusual structural configuration or complexity.

1.3.4 For large container ships, the effects of whipping and springing on the structural integrity are to be addressed. The ShipRight notations **WDA** (Whipping Design Assessment) and **FDA SPR** (Springing Fatigue Assessment) are mandatory for ships that meet the application criteria specified in *Pt 4, Ch 8, 14.3 Procedures for verification of structural response due to whipping, springing and fatigue*, see also *Table 8.14.1 Summary of direct calculation analysis requirements for container ships*.

1.3.5 The ShipRight notations **SDA, FDA, FDA SPR, WDA** may be applied on a voluntary basis. In which case all the requirements of the relevant procedures and supporting procedures are to be applied.

1.4 Information required

1.4.1 In addition to the information and plans required by *Pt 3, Ch 1, 5 Information required*, the following are to be submitted:

- (a) Details of overlap arrangement of steps in decks and longitudinal bulkheads.
- (b) Details of outline stowage arrangement of containers.
- (c) Details of design container stack weights.
- (d) Details of cell guides and supporting structure indicating the position of guides relative to hatch corners, and attachment to structural members.
- (e) Details of reinforcement to structure in way of container corners/supports.
- (f) Details of reinforcement to structure in way of lashing bridges where fitted.
- (g) Details showing the location of all openings in decks within the cargo holds.
- (h) Details of longitudinal girders supporting hatch coamings where fitted.

1.5 Symbols and definitions

1.5.1 The following symbols and definitions are applicable to this Chapter unless otherwise stated:

L , L_{pp} , B , D , T , V , C_b as defined in *Pt 3, Ch 1, 6 Definitions*

e = base of natural logarithms, 2,7183

k_L , k = higher tensile steel factor, see *Pt 3, Ch 2, 1 Materials of construction*

s = spacing of secondary stiffeners, in mm

s_1 = spacing of secondary stiffeners, but is not to be taken less than $470 + 1,67L$ mm

t = thickness of plating, in mm

L_1 = L but need not be taken greater than 190 m.

■ Section 2 Materials

2.1 Materials

2.1.1 Materials are to comply with *Pt 3, Ch 2 Materials*.

2.1.2 Attention is drawn to the specific requirements for container ship hatch corners in *Table 2.2.1 Buckling factors of safety*, λ , Note 1 in *Pt 3, Ch 2 Materials*.

2.2 Protection of steelwork

2.2.1 In addition to the requirements of *Pt 3, Ch 2, 3 Corrosion protection* the requirements of *Pt 4, Ch 1, 2.2 Protection of steelwork 2.2.3* may also be applied.

2.3 Requirements for use of thick steel plates

2.3.1 This Section provides the requirements for crack arrest design to reduce the risk of brittle fractures in container ships where thick steel plates are applied for longitudinal structural members within the cargo hold region.

2.3.2 This Section is to be applied to container ships where the steel plates for longitudinal structural members exceed a thickness of 50 mm but are not greater than 100 mm. Special consideration is required for plates with a thickness exceeding 100 mm.

2.3.3 This Section applies to plates having specified minimum yield strength of 355, 390 and 460 N/mm². Steels and weldments are to comply with the toughness requirements of *Ch 3 Rolled Steel Plates, Strip, Sections and Bars, Ch 11 Approval*

of *Welding Consumables* and *Ch 12 Welding Qualifications* of the *Rules for the Manufacture, Testing and Certification of Materials* (hereinafter referred to as the *Rules for Materials*).

2.3.4 The approach in this Section generally applies to the erection block-to-block joints. Appropriate measures are to be considered to prevent large scale fracture of the hull girder in anticipation of the following:

- (a) Crack initiation in the block-to-block butt weld joint in either the hatch side coaming or upper deck. Crack propagates along the butt weld joint without deviation.
- (b) Crack initiation in the block-to-block butt weld joint in either the hatch side coaming or upper deck. Crack propagates away from the butt weld joint running into base metal.
- (c) Crack initiation in any welded joint, for example in way of attachment welds, and deviates away from the butt weld joint running into base metal.

2.3.5 The detailed arrangements for crack arrest design are to be submitted for approval.

2.3.6 Where Measure 1 is required in *Table 8.2.1 Preventative measures to be used in design and construction for thick steel plates*, 100 per cent ultrasonic testing in accordance with *Ch 13, 2.12 Non-destructive examination of welds* of the *Rules for Materials*, both application and acceptance criteria, is to be carried out on all block-to-block butt joints of all upper flange longitudinal structural members in the cargo hold region. Upper flange longitudinal structural members include the topmost strakes of the inner hull/bulkhead, the sheer strake, main deck, coaming plate, coaming top plate, and all attached longitudinal stiffeners. These members are defined in *Figure 8.2.1 Upper flange longitudinal structural members*.

Table 8.2.1 Preventative measures to be used in design and construction for thick steel plates

Nominal yield strength (N/mm ²)	Thickness (mm)	Measure		
		1	2 (see Note 1)	3 (see Note 1)
355	50 < t ≤ 85	Not required	Not required	Not required
	85 < t ≤ 100	Required	Not required	Not required
390	50 < t ≤ 85	Required	Not required	Not required
	85 < t ≤ 100	Required	Required (see Note 2)	Required
460	50 < t ≤ 85	Required	Required (see Note 2)	Required
	85 < t ≤ 100	Required	Required (see Note 2)	Required

Key to measures:

Measure 1: This measure is mandatory where 'Required' is shown, see *Pt 4, Ch 8, 2.3 Requirements for use of thick steel plates 2.3.6*.

Measure 2: Design based on crack arrest, see *Pt 4, Ch 8, 2.3 Requirements for use of thick steel plates 2.3.7* and *Pt 4, Ch 8, 2.3 Requirements for use of thick steel plates 2.3.8*.

Measure 3: Design based on crack initiation, see *Pt 4, Ch 8, 2.3 Requirements for use of thick steel plates 2.3.12*.

Note 1 Measure 2 or Measure 3 is to be applied where 'Required' is shown.

Note 2 Brittle crack arrest steel to be applied for upper deck along the cargo hold region to prevent crack propagation from the coaming into lower structure.

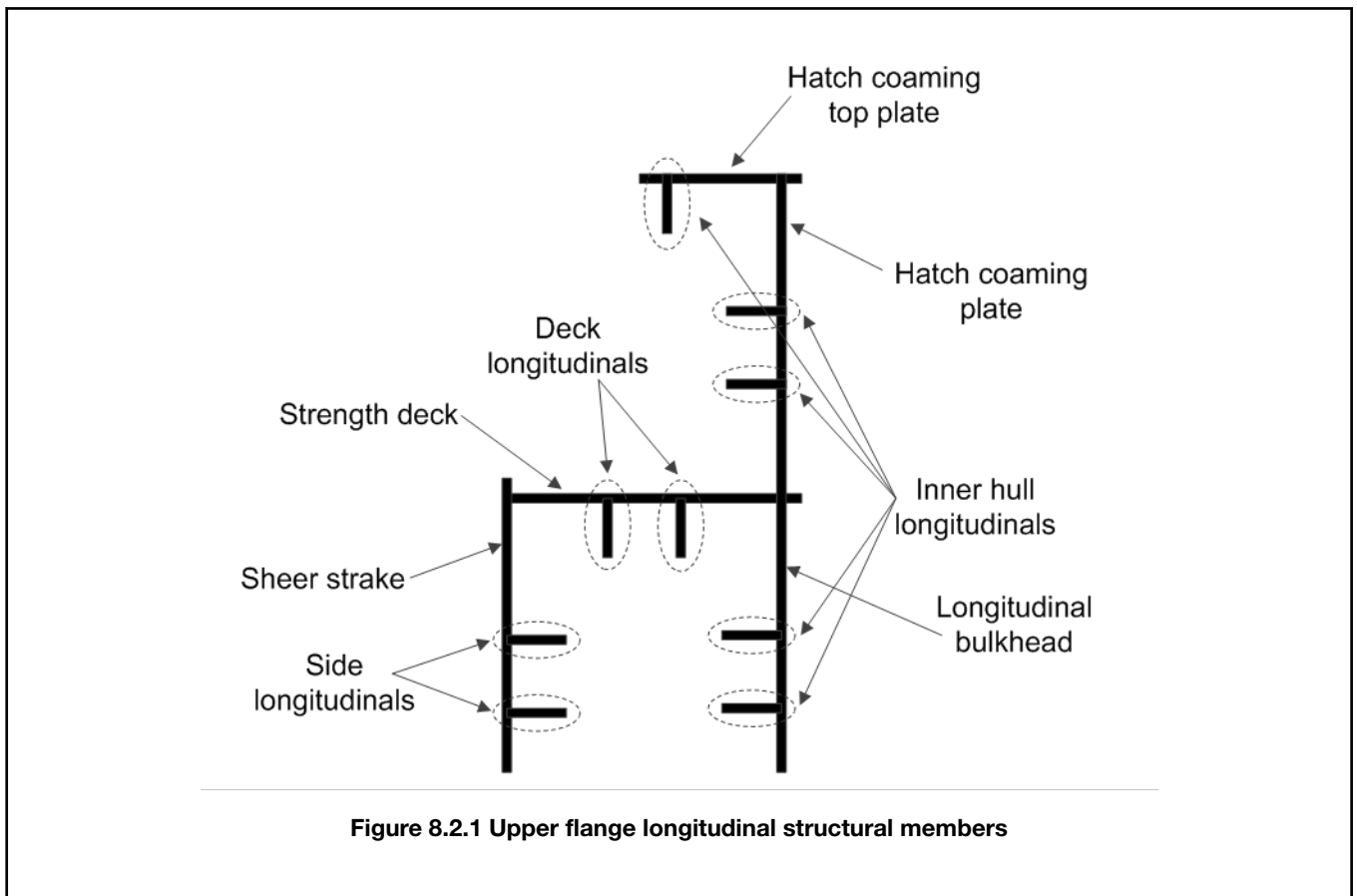

2.3.7 The following are considered to be acceptable examples of brittle crack arrest design for the case given in Pt 4, Ch 8, 2.3 Requirements for use of thick steel plates 2.3.4 and Pt 4, Ch 8, 2.3 Requirements for use of thick steel plates 2.3.4:

- (a) Where the block-to-block butt welds of the hatch side coaming and those of the upper deck are staggered, this offset is to be greater than or equal to 300 mm. This offset distance is defined in Figure 8.2.2 Minimum offset between block-to-block butt welds of the hatch side coaming and those of the upper deck staggered. Brittle crack arrest steel, as defined in Pt 4, Ch 8, 2.3 Requirements for use of thick steel plates 2.3.9, is to be provided for the hatch side coaming.
- (b) Where crack arrest holes are provided in way of the block-to-block butt welds at the region where the hatch side coaming weld meets the deck weld, see Figure 8.2.3 Crack arrest hole in way of the block-to-block butt weld at the region where hatch side coaming weld meets the deck weld, the corners of the crack arrest holes located where the hatch side coaming joints meet the deck weld are to be specially assessed for fatigue strength. The fatigue strength is also to be assessed at the location where the block-to-block butt weld intersects the crack arrest hole. Brittle crack arrest steel, as defined in Pt 4, Ch 8, 2.3 Requirements for use of thick steel plates 2.3.9, is to be provided for the hatch side coaming.
- (c) Where higher crack arrest steel insert plates such as SUF (Surface Layer with Ultra-Fine grain) steel or equivalent, or weld metal inserts with high crack arrest toughness properties are provided in way of the block-to-block butt welds at the region where hatch side coaming weld meets the deck weld. Brittle crack arrest steel, as defined in Pt 4, Ch 8, 2.3 Requirements for use of thick steel plates 2.3.9, is to be provided for the hatch side coaming.

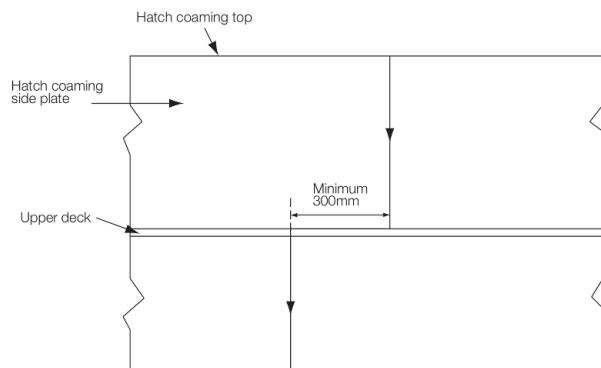

Figure 8.2.2 Minimum offset between block-to-block butt welds of the hatch side coaming and those of the upper deck staggered

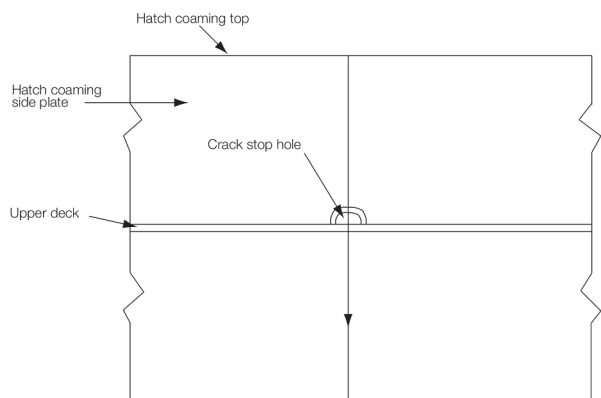

Figure 8.2.3 Crack arrest hole in way of the block-to-block butt weld at the region where hatch side coaming weld meets the deck weld

2.3.8 For the case given in Pt 4, Ch 8, 2.3 Requirements for use of thick steel plates 2.3.4, brittle crack arrest steel, as defined in Pt 4, Ch 8, 2.3 Requirements for use of thick steel plates 2.3.9, is to be used for the upper deck along the cargo hold region to arrest a brittle crack initiating from the coaming plate and propagating into the structure below.

2.3.9 Brittle crack arrest steel is to be in accordance with the Rules for Materials, Ch 3, 3 Higher strength steels for ship and other structural applications.

2.3.10 Where higher crack arrest steel or weld inserts are proposed, as given in Pt 4, Ch 8, 2.3 Requirements for use of thick steel plates 2.3.7, the specific properties or grades of material are to be agreed with LR.

2.3.11 As an alternative to Pt 4, Ch 8, 2.3 Requirements for use of thick steel plates 2.3.7, consideration may be given to the use of crack arrest steel in all the structural parts of the hatch coaming top, hatch coamings, upper deck and first strake below the upper deck.

2.3.12 As an alternative to crack arrest design, design based on crack initiation may be considered. Design based on this approach aims to prevent any defect from propagating into a brittle fracture by ensuring that no defect exists above a calculated

size in the weld either during construction or subsequently in service. This size is determined by way of an Engineering Critical Assessment (ECA) which must be carried out and submitted to LR prior to construction. The ECA will determine the minimum acceptable defect size from both fatigue crack growth and fracture mechanics calculations. The detectability of such a defect in the structure will also need to be proven to LR. This can only be achieved through assessment of the non-destructive examination techniques and procedures to be applied. It is anticipated that, for this approach to be successful, the application of advanced NDT, such as the Time of Flight Diffraction (TOFD) Technique, will be necessary. The approach will also need to include a programme of non-destructive testing during the lifetime of the ship to ensure that growth of a defect does not exceed the limits of the ECA.

2.3.13 *Table 8.2.1 Preventative measures to be used in design and construction for thick steel plates* summarises a selection of measures aimed at mitigating the risk of uncontrolled brittle fracture in way of deck and hatch coaming structure. A range of thicknesses is shown for the different strength grades of steel; where the maximum as-built thickness falls within this range, measures are to be selected as shown in the Table. If the as-built thickness of the hatch coaming structure is below the values contained in the Table, then additional measures are not necessary.

■ **Section 3**
Longitudinal strength

3.1 General

3.1.1 Longitudinal strength calculations are to be carried out in accordance with *Pt 4, Ch 8, 3.2 Longitudinal strength* and *Pt 4, Ch 8, 3.3 Combined longitudinal and torsional strength 3.3.1*

3.1.2 Alternatively the values and distributions of wave induced loads may be derived by direct calculation in accordance with LR's *ShipRight Procedure Guidance Notes on the Assessment of Global Design Loads of Large Container Ships and Other Ships Prone to Whipping and Springing*.

3.1.3 For ships of abnormal hull form, or for ships of unusual structural configuration or complexity, the values and distributions of wave induced loads are to be agreed with LR. LR may decide to mandate the application of the ShipRight notations; **SDA, FDA, FDA SPR** or **WDA**.

3.2 Longitudinal strength

3.2.1 Longitudinal strength calculations are to be made in accordance with the requirements of *Pt 3, Ch 4 Longitudinal Strength* and the additional notes contained in this Section and *Pt 4, Ch 8, 14 Direct calculation*.

3.2.2 The design vertical wave bending moments and design wave shear forces are to be determined in accordance with *Pt 4, Ch 2, 2.4 Design vertical wave bending moments* and *Pt 4, Ch 2, 2.5 Design wave shear force* and are to be used in *Pt 3, Ch 4 Longitudinal Strength*.

3.2.3 The values of sagging f_S and hogging f_H correction factors due to non-linear effects of the hull shape are to be derived by non-linear ship motion analysis based on equivalent design sea state methods where the following condition applies:

- (a) $L > 300$ m and one or more of
 - (i) $|f_{fS}| > 1,4$ or
 - (ii) $RA_{BF} > 0,2$ or
 - (iii) $RA_{BFU} > 0,2$

where

- (a) f_{fS} and f_{fH} = are defined in *Pt 4, Ch 2, 2.4 Design vertical wave bending moments 2.4.1*

RA_{BF} = is the bow flare area ratio for the lower region just above the still waterline

$$= \left(\frac{A_{BF}}{0,1LB_{WL}} \right)$$

- (b) RA_{BFU} = is the bow flare area ratio for the upper region near the deck

$$= \begin{pmatrix} A_{BFU} \\ 0, 1LB_{WL} \end{pmatrix}$$

A_{BF}, B_{WL} = are defined in Pt 4, Ch 2, 2.4 Design vertical wave bending moments 2.4.1

A_{BFU} = is the bow flare area in m² for the region from a waterline of $T_{C,U}$ to $T_{C,2U}$, calculated in the same way as A_{BF} see Pt 4, Ch 2, 2.4 Design vertical wave bending moments 2.4.1

$T_{C,2U}$ = $T + C_1$ m or the local deck edge height if this is lower

C_1 = is defined in Table 4.5.1 Superstructures and deckhouses on forecastle deck in Pt 3, Ch 4 Longitudinal Strength

The methodology to calculate the non-linear ship motion wave loads is given in LR's ShipRight Procedure *Guidance Notes on the Assessment of Global Design Loads of Large Container Ships and Other Ships Prone to Whipping and Springing*.

3.3 Combined longitudinal and torsional strength

- (a) The strength of the ship to resist a combination of longitudinal and torsional loads is to be determined in accordance with Pt 4, Ch 8, 15.1 Application.

Section 4 Deck structure

4.1 General

- 4.1.1 The requirements of Pt 4, Ch 1, 4 Deck structure are to be complied with as modified by this Section.
- 4.1.2 The strength deck is to be longitudinally framed throughout the region of container holds for ships where $L \geq 100$ m.
- 4.1.3 Lower decks/side stringers are to be efficiently scarfed into the machinery space, and the fore end and aft end structure.
- 4.1.4 The ShipRight FDA Procedure, *Structural Detail Design Guide (SDDG)*, indicates recommended examples of structural design configurations in critical areas of deck structures.

4.2 Primary supporting structure

4.2.1 Where decks form part of the primary support structures described in Pt 4, Ch 8, 6.2 Side shell primary supporting structure and Pt 4, Ch 8, 9.2 Transverse watertight/non-watertight bulkhead primary supporting structure the scantlings of the decks are to be verified by direct calculation procedures in accordance with Pt 4, Ch 8, 14.2 Procedures for verification of primary structure scantlings.

4.3 Deck plating and stiffeners

4.3.1 Strength/weather deck scantlings outside the line of hatch openings are to satisfy the requirements of Pt 4, Ch 8, 3 Longitudinal strength and Pt 4, Ch 8, 4.2 Primary supporting structure, and are to be not less than required by Pt 4, Ch 1, 4.2 Deck plating and Pt 4, Ch 1, 4.3 Deck stiffening.

4.3.2 Within the cargo holds, strength/weather/second deck scantlings inside the line of hatch openings are to satisfy the requirements of Pt 4, Ch 8, 3 Longitudinal strength, Pt 4, Ch 8, 4.2 Primary supporting structure and Pt 4, Ch 8, 4.4 Cross decks.

4.3.3 Other deck scantlings are to satisfy the requirements of Pt 4, Ch 8, 3 Longitudinal strength, Pt 4, Ch 8, 4.2 Primary supporting structure and Pt 4, Ch 1, 4 Deck structure as appropriate.

4.4 Cross decks

4.4.1 The width and scantlings of cross-deck strips are to satisfy the requirements of Pt 4, Ch 8, 4.2 Primary supporting structure. The thickness, t , of cross-deck strips is to comply with the requirements of Table 8.4.1 Cross deck plating.

Table 8.4.1 Cross deck plating

Location	Minimum thickness, in mm
At strength deck	The greater of the following: (a) $t = 0,012s_1$ (b) $t = 10 + 0,01L_1$
At second deck	The greater of the following: (a) $t = 0,012s_1$ but need not exceed 12 (b) $t = 8,0$
Symbols	
s_1 and L_1 as defined in Pt 4, Ch 8, 1.5 Symbols and definitions 1.5.1.	

4.4.2 The thickness may require to be increased locally in way of access openings.

4.4.3 Where the difference between the thickness of plating inside and outside the line of main hatchway openings exceeds 25 mm, a single transition plate is to be fitted at the end of the cross deck strip. The thickness of the transition plate is to be equal to the mean of the adjacent plate thicknesses.

4.4.4 The scantlings of cross-deck stiffeners are to comply with Pt 4, Ch 1, 4 Deck structure.

4.4.5 For initial design purposes the width of the cross deck strips, w , forming a transverse bulkhead top box (or equivalent) can be estimated according to the following formula:

$$w = 32,5B + 400, \text{ or } 1000 \text{ mm, whichever is the greater}$$

where B is given in Pt 4, Ch 8, 1.5 Symbols and definitions 1.5.1.

4.5 Deck openings

4.5.1 The corners of main hatchway openings are generally to be rounded. However, corners with negative radii, or parabolic or elliptic profiles will be specially considered.

4.5.2 The design of hold corners including deck thickness and corner profile is to comply with either Pt 4, Ch 8, 4.5 Deck openings 4.5.3 or Pt 4, Ch 8, 4.5 Deck openings 4.5.4.

4.5.3 The design of hatch corners is to be verified by direct calculations, see Pt 4, Ch 8, 14.1 Procedures for calculation of combined longitudinal and torsional strength 14.1.1.

4.5.4 Alternatively, where the design of hatch corners has not been verified by direct calculations:

- (a) The outboard radius of main hatchway openings at strength deck level is, in general, to be not less than 35 per cent of the width of the cross-deck strip indicated in Pt 4, Ch 8, 4.4 Cross decks 4.4.5 with a minimum of 300 mm.
- (b) The radius of the hatch corners of the main hatchway openings adjacent to the engine room is to be made as large as practicable, with a radius of approximately $40B$ mm.
- (c) Insert plates at main hatch corners are to have an increased thickness above the adjacent plating outside the line of hatchways of 15 per cent in way of the container holds, and 25 per cent in container holds at engine room bulkheads. The minimum increase is to be not less than 4,0 mm, nor need exceed 7,0 mm, and the minimum fore and aft extent is to be 1,0 m from the edge of the openings.

4.6 Local reinforcement

4.6.1 Attention is to be paid to structural continuity, and abrupt changes of shape, section or plate thickness are to be avoided, particularly in highly stressed areas. Arrangements in way of openings are to be such as to minimise the creation of stress concentrations.

4.6.2 In general, large access openings are not to be arranged in the strength deck outside the line of main hatchways in the region of container holds.

4.6.3 Small openings, such as those for ventilation pipes or scuppers, are to be kept clear of hold corners, ends of longitudinal hatch coamings, ends of cross-deck strips and other critical locations.

4.7 Support for container corner seats

4.7.1 In general, local stiffening is to be fitted under seats for container supports.

4.7.2 The design of attachments to the strength deck is to minimise the effects of stress concentration, and consideration is to be given to the strength and grade of welding consumable used, see, *Ch 13, 2.2 Welding consumables 2.2.2* of the *Rules for the Manufacture, Testing and Certification of Materials, July 2015* (hereinafter referred to as the Rules for Materials).

4.7.3 The strength of support arrangements is to be verified in accordance with *Pt 3, Ch 14, 4 Ship structure*.

4.7.4 Doubler plates are not to be utilised in connections subject to tensile loads.

■ Section 5 **Shell envelope plating**

5.1 General

5.1.1 The requirements of *Pt 4, Ch 1, 5 Shell envelope plating* are to be applied, together with the requirements of this Section.

5.1.2 The bottom shell is, in general, to be longitudinally framed for ships where $L \geq 100$ m.

5.1.3 The side shell may be longitudinal or transversely framed, except in way of the topside torsion box which is, in general, to be longitudinally framed.

5.2 Bottom shell and bilge

5.2.1 The thickness of the bottom shell plating is to satisfy the requirements of *Pt 4, Ch 8, 3 Longitudinal strength* and *Pt 4, Ch 8, 7.2 Double bottom primary supporting structure* and is to be not less than required by *Pt 4, Ch 1, 5.3 Bottom shell and bilge*.

5.2.2 In regions where transverse framing is adopted, particularly towards the end of the ship, the buckling stability of the plating will be specially considered.

5.3 Side shell and sheerstrake

5.3.1 The thickness of the side shell and sheerstrake plating is to satisfy the requirements of *Pt 4, Ch 8, 3 Longitudinal strength* and *Pt 4, Ch 8, 6.2 Side shell primary supporting structure* and is to be not less than required by *Pt 4, Ch 1, 5.4 Side shell*.

5.3.2 At positions where high shear forces are present, local increases in thickness may be required.

5.3.3 The difference in thickness between the sheerstrake and shell plating below is not to exceed 25 mm.

■ Section 6 **Shell envelope framing**

6.1 General

6.1.1 The requirements of *Pt 4, Ch 1, 6 Shell envelope framing* are to be applied, together with the requirements of this Section.

6.1.2 The ShipRight FDA Procedure, *Structural Detail Design Guide (SDDG)* indicates recommended examples of configurations for end connections of shell envelope longitudinals.

6.2 Side shell primary supporting structure

6.2.1 A primary supporting structure for side shell envelope framing is to be provided of either single or double skin construction. This normally consists of a combination of vertical transverse webs and horizontal side stringers/decks.

6.2.2 Transverse webs supporting side shell envelope framing are to be arranged in line with the floors in the double bottom to ensure continuity of transverse strength.

6.2.3 The scantlings of double skin primary structure, including thickness of side shell envelope plating, are to be verified by direct calculations in accordance with *Pt 4, Ch 8, 14.2 Procedures for verification of primary structure scantlings*.

6.2.4 The scantlings of single skin primary structure are to comply with *Pt 4, Ch 1, 6.4 Primary supporting structure*. Alternatively the scantlings are to be verified by direct calculations in accordance with *Pt 4, Ch 8, 14.2 Procedures for verification of primary structure scantlings*.

6.3 Side stringers in double skin construction

6.3.1 The scantlings of side stringers are to satisfy the requirements of *Pt 4, Ch 8, 3 Longitudinal strength*, *Pt 4, Ch 8, 6.2 Side shell primary supporting structure* and *Pt 4, Ch 8, 6.5 Minimum thickness of transverse webs/side stringers in double skin construction*.

6.3.2 In addition, the scantlings of watertight side stringers are to satisfy the requirements of *Pt 4, Ch 1, 9 Bulkheads*.

6.4 Transverse webs in double skin construction

6.4.1 The scantlings of transverse webs are to satisfy the requirements of *Pt 4, Ch 8, 6.2 Side shell primary supporting structure* and *Pt 4, Ch 8, 6.5 Minimum thickness of transverse webs/side stringers in double skin construction*.

6.4.2 Transverse webs are to be efficiently stiffened, and the thickness increased locally where necessary on account of high shear stress.

6.4.3 Where, towards the end of the ship, the width of transverse webs reduces from that assumed in the direct calculations, the thickness may require to be increased locally.

6.5 Minimum thickness of transverse webs/side stringers in double skin construction

6.5.1 Transverse webs and side stringers are to have a thickness, t , not less than:

$$t = 7,5 + 0,015L \text{ or } 9 \text{ mm, whichever is the lesser.}$$

■ *Section 7*
Double bottom structure

7.1 General

7.1.1 The double bottom is, in general, to be longitudinally framed for ships where $L \geq 100$ m.

7.1.2 Longitudinally framed double bottoms are to comply with *Pt 4, Ch 1, 8.2 General* and the contents of this Section.

7.1.3 Transversely framed double bottoms are to comply with *Pt 4, Ch 1, 8 Double bottom structure*.

7.1.4 The ShipRight FDA Procedure, *Structural Detail Design Guide (SDDG)*, indicates recommended examples of structural design configurations in critical areas of the double bottom.

7.2 Double bottom primary supporting structure

7.2.1 The primary supporting structure formed by the double bottom comprises inner bottom plating, floors, longitudinal girders and bottom shell plating.

7.2.2 The scantlings of this primary structure are to be verified by direct calculations in accordance with *Pt 4, Ch 8, 14.2 Procedures for verification of primary structure scantlings*.

7.2.3 Where, towards the end of the ship, the depth of double bottom structure webs is reduced from that assumed in the direct calculations, the thickness may require to be increased locally.

7.2.4 Where mid-hold or quarter-length-of-hold supports for the double bottom structure are arranged, these are to take the form of an efficiently stiffened transverse box or open section structure, see *Pt 4, Ch 8, 9.4 Transverse non-watertight mid-hold bulkheads*.

7.3 Inner bottom plating and stiffening

7.3.1 The scantlings of the inner bottom are to satisfy the requirements of *Pt 4, Ch 8, 3 Longitudinal strength* and *Pt 4, Ch 8, 7.2 Double bottom primary supporting structure* and are to be not less than required by *Pt 4, Ch 1, 8.4 Inner bottom plating and stiffening* as modified by this sub-Section.

7.3.2 The requirements of *Pt 4, Ch 1, 8.4 Inner bottom plating and stiffening 8.4.2* need not be applied to container ships.

7.3.3 In applying *Pt 4, Ch 1, 8.4 Inner bottom plating and stiffening 8.4.5*, the Rule value of bottom longitudinals may be calculated assuming $F_{sb} = 1,05$.

7.4 Girders

7.4.1 Girders are, in general, to be arranged under container corner seatings.

7.4.2 The scantlings of watertight centreline/side girders are to satisfy the requirements of *Pt 4, Ch 8, 3 Longitudinal strength* and *Pt 4, Ch 8, 7.2 Double bottom primary supporting structure* and are to be not less than required by *Pt 4, Ch 1, 8.3 Girders*.

7.4.3 The scantlings of non-watertight centreline/side girders are to satisfy the requirements of *Pt 4, Ch 8, 3 Longitudinal strength* and *Pt 4, Ch 8, 7.2 Double bottom primary supporting structure*.

7.4.4 For double bottoms having a depth greater than 1,6 m, additional longitudinal stiffening may have to be introduced in order to ensure the buckling stability of the girders.

7.5 Floors

7.5.1 Plate floors are to be fitted under watertight bulkheads, non-watertight bulkheads/mid-hold supports, under container corners at hold quarter length locations and at other locations to ensure that the maximum spacing does not, in general, exceed 3,8 m. Proposals for floor spacings greater than 3,8 m are to be supported by direct calculations agreed with LR.

7.5.2 The scantlings of watertight floors are to satisfy the requirements of *Pt 4, Ch 8, 7.2 Double bottom primary supporting structure* and are to be not less than required by *Pt 4, Ch 1, 8.5 Floors*.

7.5.3 The thickness, t , of non-watertight floors is to satisfy the requirements of 7.2 and is to be not less than:

$$t = 6 + 0,03L \text{ or } 12 \text{ mm, whichever is the lesser.}$$

7.5.4 Non-watertight floor stiffeners are to be fitted at approximately the same spacing as the bottom longitudinals. The scantlings are to satisfy the requirements of *Pt 3, Ch 10 Welding and Structural Details*.

7.5.5 Docking brackets, or equivalent, are to be fitted in accordance with *Pt 4, Ch 1, 8.5 Floors 8.5.3*.

7.6 Support for containers

7.6.1 In general, local stiffening is to be fitted to double bottom floors or girders under container corner seatings in order to ensure the effective transmission of load.

7.6.2 Such stiffening normally takes the form of additional brackets with suitable extensions to adjacent stiffening members. The scantlings of the adjacent stiffening members may require to be increased depending on the arrangements proposed.

7.6.3 Attention is drawn to the benefit of direct support in order to minimise the effect of eccentric loading on the support brackets.

7.6.4 The scantlings of these arrangements may be determined utilising simple beam models to verify the shear and bending strength. Based on static container loads, the stresses induced in the structure are not to exceed the permissible values stated in *Table 8.7.1 Permissible stress values*. Alternative more complex assessment methods are to be agreed with LR.

7.6.5 In general, doubling members or equivalent structures are to be attached to the inner bottom to distribute the load from container corners into the supporting structure. Doubler plates are to have well-rounded corners.

Table 8.7.1 Permissible stress values

	Permissible stress, N/mm ² (kgf/mm ²)
Normal stress (bending, tension, compression)	0,67σ ₀
Shear stress	0,4σ ₀
Combined stress	0,86σ ₀
Symbols	
σ ₀ = specified minimum yield stress, in N/mm ² (kgf/mm ²)	

■ **Section 8**
Longitudinal bulkheads

8.1 General

- 8.1.1 The requirements of *Pt 4, Ch 1, 9 Bulkheads* are to be applied, together with the requirements of this Section.
- 8.1.2 Longitudinal bulkheads may be transversely or longitudinally framed, except in way of the topside torsion box which is, in general, to be longitudinally framed.
- 8.1.3 Longitudinal bulkheads are to be maintained continuous in way of the machinery space where this is situated between container holds and as far forward and aft as practicable.
- 8.1.4 The scarfing arrangements in way of the steps are to be sufficient to ensure an efficient overlap of the inner skin bulkheads.
- 8.1.5 The ShipRight FDA Procedure, *Structural Detail Design Guide (SDDG)*, indicates recommended examples of structural design configurations in critical areas of the double side skin structures.

8.2 Side shell primary supporting structure

8.2.1 Where the longitudinal bulkhead forms the inner skin of the side shell primary supporting structure the thickness of longitudinal bulkhead plating is to be verified by direct calculations as described in *Pt 4, Ch 8, 14.2 Procedures for verification of primary structure scantlings*.

8.3 Plating and stiffeners

- 8.3.1 The scantlings of longitudinal bulkheads are to satisfy the requirements of *Pt 4, Ch 8, 3 Longitudinal strength* and *Pt 4, Ch 8, 8.2 Side shell primary supporting structure* and are to be not less than required by *Pt 4, Ch 1, 9 Bulkheads*.
- 8.3.2 Openings in the upper parts of longitudinal bulkheads are to have shapes which minimise stress concentrations and are to be framed to ensure adequate buckling stability.
- 8.3.3 The difference in thickness between the top strake and the bulkhead plating below is not to exceed 25 mm.

8.4 Support for container corner seats

- 8.4.1 Where direct support for 20 ft containers by the longitudinal bulkhead is required at the mid length of a cell arranged for 40 ft containers, adequate stiffening is to be fitted in order to ensure the effective transmission of load.
- 8.4.2 The strength of these arrangements is to be verified in accordance with *Pt 3, Ch 14, 4 Ship structure*.

■ Section 9

Transverse bulkheads

9.1 General

9.1.1 The requirements of *Pt 4, Ch 1, 9 Bulkheads* are to be applied, together with the requirements of this Section.

9.1.2 Watertight transverse bulkheads may be vertically or horizontally framed.

9.1.3 The ShipRight FDA Procedure, *Structural Detail Design Guide (SDDG)*, indicates recommended examples of structural design configurations in critical areas of transverse bulkhead structures.

9.2 Transverse watertight/non-watertight bulkhead primary supporting structure

9.2.1 The primary supporting structure of transverse bulkheads normally comprises a grillage of vertical webs and horizontal stringers/decks.

9.2.2 Vertical webs are to be fitted in line with double bottom girders.

9.2.3 The scantlings of transverse bulkhead primary structure including bulkhead plating are to be verified by direct calculations as described in *Pt 4, Ch 8, 14.2 Procedures for verification of primary structure scantlings*.

9.2.4 The scantlings are to be adequate for the static and dynamic loads imposed on the structure by the container stowage arrangements.

9.3 Transverse watertight bulkheads

9.3.1 The thickness of the transverse bulkhead plating is to satisfy the requirements of *Pt 4, Ch 8, 9.2 Transverse watertight/non-watertight bulkhead primary supporting structure* and is to be not less than required by *Pt 4, Ch 1, 9.2 Watertight and deep tank bulkheads* for watertight bulkheads.

9.3.2 In general, a transverse box structure or equivalent is to be arranged at upper deck level.

9.3.3 In certain cases, a transverse box structure at the inner bottom may also be required.

9.4 Transverse non-watertight mid-hold bulkheads

9.4.1 Where non-watertight bulkheads are arranged in conjunction with the double bottom mid-hold support, a transverse box is to be arranged at strength deck level.

9.4.2 Non-watertight bulkhead scantlings are to satisfy the requirements of *Pt 4, Ch 8, 9.2 Transverse watertight/non-watertight bulkhead primary supporting structure* and *Pt 4, Ch 1, 4.4 Deck supporting structure* for a non-watertight pillar bulkhead.

■ Section 10

Hatch coamings and support for hatch covers

10.1 Hatch coamings

10.1.1 Scantlings of hatch coamings are to comply with *Pt 3, Ch 11, 5 Hatch coamings* in addition to the requirements of this Section.

10.1.2 Continuous side coamings are to be effectively scarfed into the deckhouse structure or gradually tapered at ends, as applicable. The scantlings are also to satisfy the requirements of *Pt 4, Ch 8, 3 Longitudinal strength*.

10.1.3 The scantlings of transverse hatch coamings forming part of a transverse bulkhead top box are also to satisfy the requirements of *Pt 4, Ch 8, 9.2 Transverse watertight/non-watertight bulkhead primary supporting structure*.

10.1.4 The ShipRight FDA Procedure, *Structural Detail Design Guide (SDDG)*, indicates examples of recommended structural design configurations in critical areas of the hatch side coamings.

10.2 Support for inboard edges of hatch covers by girders

10.2.1 Where longitudinal underdeck girders are fitted at deck level to support the hatch covers the requirements of this sub-Section are to be complied with.

10.2.2 The girders may take the form of open or closed box sections and these should align with webs on the transverse bulkheads to form a continuous ring structure.

10.2.3 The girders are, in general, to be continuous throughout the container hold area, including the engine room where this is situated between container holds.

10.2.4 Special attention is to be given to the intersection of the girders with transverse box girders and the integration into the fore end, aft end and machinery space structures.

10.2.5 Where girders are integrated into the cross-deck strips, inserts plates with integral gussets are to be incorporated. The inserts are to have a thickness not less than that of the girder top and bottom plates, as appropriate. The radius of main hatchway openings in way of ends of hatch girders at upper deck level is, in general, to be not less than 20 per cent of the width of the cross-deck strip indicated in Pt 4, Ch 8, 4.4 Cross decks 4.4.5 with a minimum of 250 mm.

10.2.6 Scantlings of girders are to comply with the requirements of Pt 4, Ch 1, 4 Deck structure.

10.3 Support for hatch cover fittings

10.3.1 The width of hatch coaming top plates is to be suitable to accommodate the hatch covers and associated fittings.

10.3.2 Local stiffening is to be fitted below hatch cover supporting devices and in some cases the thickness of the coaming in way may need to be increased, (see also Pt 3, Ch 11, 4.2 Steel covers – Clamped and gasketed 4.2.3 and Pt 3, Ch 11, 5.2 Construction 5.2.12).

■ Section 11 Hatch covers

11.1 General

11.1.1 The requirements of Pt 3, Ch 11 Closing Arrangements for Shell, Deck and Bulkheads are to be complied with in addition to the requirements of this Section.

11.1.2 The primary structure of hatch covers normally consists of an arrangement of deep beams and girders including hatch cover top plating.

11.1.3 For hatch covers subjected to point loads from containers, the primary structure scantlings are to be verified by direct calculation in accordance with Pt 4, Ch 8, 11.2 Direct calculations.

11.1.4 Local stiffening is to be arranged below container corners. The substructures of container foundations are to be designed for cargo and container loads according to Pt 3, Ch 11, 2.3 Load model, applying the permissible stresses according to Pt 3, Ch 11, 2.4 Allowable stress and deflection 2.4.1.

11.2 Direct calculations

11.2.1 Direct calculations are to be based on 2D or 3D finite element analysis. Simplified boundary constraints may be applied in the modelling, provided this does not compromise the overall structural response.

11.2.2 Where containers are stowed on hatch covers, the following loads due to heave, pitch, and the ship's rolling motion are to be considered, see Figure 8.11.1 Forces due to container loads:

$$A_z = 9,81 \frac{M}{2} (1 + a_v) \left(0,45 - 0,42 \frac{h_m}{b} \right) \text{ kN}$$

$$B_z = 9,81 \frac{M}{2} (1 + a_v) \left(0,45 + 0,42 \frac{h_m}{b} \right) \text{ kN}$$

$$B_y = 2,4M \text{ kN}$$

The loads due to single forces resulting from heave and pitch are also to be considered, as defined in *Pt 3, Ch 11, 2.3 Load model 2.3.5*, where

a_v = acceleration addition according to *Pt 3, Ch 11, 2.3 Load model 2.3.4*

b = distance between foot points, in metres

h_m = designed height of centre of gravity of stack above hatch cover supports, in metres

A_z, B_z = support forces in z-direction at the forward and aft stack corners, in kN

B_y = support force in y-direction at the forward and aft stack corners, in kN

M = maximum designed mass of container stack, in t .

For M and h_m , it is recommended to apply those values which are used for the calculations of cargo securing (container lashing). If different assumptions are made for M and h_m , the designer is to ensure that, in the calculation model, the hatch cover structure is not loaded by less than those values recommended.

When the strength of the hatch cover structure is assessed by FE analysis according to the ShipRight procedure *Assessment of Steel Hatch Covers using Finite Element Analysis*, h_m may be taken as the designed height of centre of gravity of stack above the hatch cover top plate. Values of M and h_m applied for the assessment of hatch cover strength are to be shown in the drawings of the hatch covers.

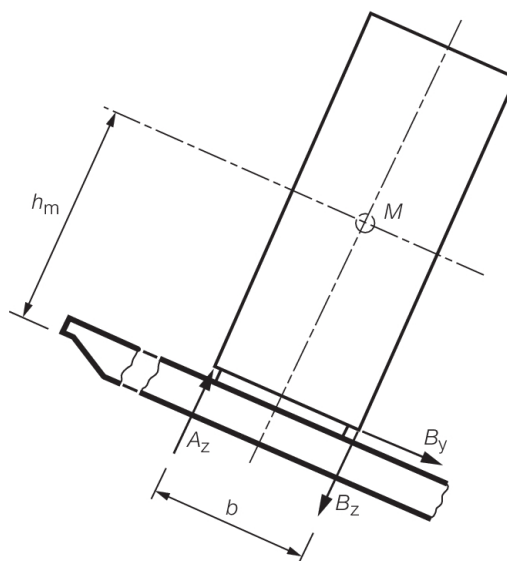

Figure 8.11.1 Forces due to container loads

11.2.3 The forces acting on hatch covers when container stacks are secured to lashing bridges or carried in cell guides will be specially considered.

11.2.4 A load case with partial non-homogeneous loading is also to be considered, e.g. where specified container stack places are empty. This may be evaluated using a simplified approach, where the hatch cover is loaded without the outermost stacks, see *Figure 8.11.2 Partial loading of a container hatch cover*.

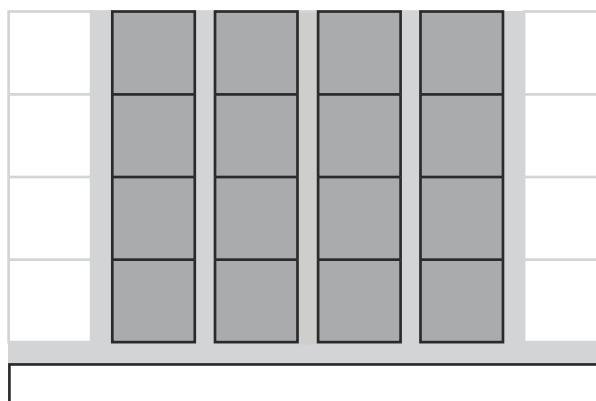

Figure 8.11.2 Partial loading of a container hatch cover

11.2.5 The securing devices of hatch covers, onto which cargo is to be lashed, are to be designed for the lifting forces resulting from loads according to Pt 4, Ch 8, 11.2 Direct calculations 11.2.2, see Figure 8.11.3 Lifting forces at a hatch cover. Unsymmetrical loadings, which may occur in practice, are to be considered. Under these loadings, the equivalent stress in the securing devices is not to exceed:

$$\sigma_v = \frac{150}{k_1} \text{ in N/mm}^2$$

Special consideration may be given for the omission of antilifting devices for non-weathertight hatch covers.

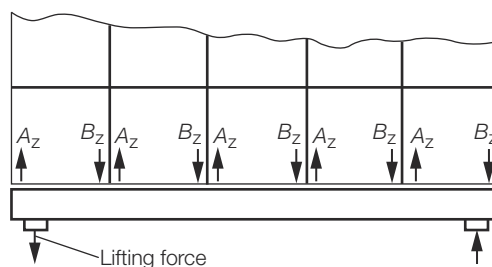

Figure 8.11.3 Lifting forces at a hatch cover

11.2.6 Where hatch covers are arranged for carrying containers and mixed stowage is allowed, i.e. a 40' container stowed on top of two 20' containers, particular attention is to be paid to the deflections of hatch covers. Furthermore, the possible contact of deflected hatch covers with in-hold cargo is to be considered.

11.3 Dispensation of weathertight gaskets

11.3.1 For hatch covers of cargo holds solely for the transport of containers, upon request by the Owners and subject to compliance with the requirements of this Section, the fitting of weathertight gaskets according to Pt 3, Ch 11, 4.4 Packing material may be dispensed with.

11.3.2 The hatchway coamings are not to be less than 600 mm in height.

11.3.3 The exposed deck on which the hatch covers are located is situated above a depth $H(x)$. $H(x)$ is to be shown to comply with the following criteria:

$$H(x) = \geq T_{fb} + f_b + h, \text{ in metres}$$

where

T_{fb} = draught, in metres, corresponding to the assigned summer load line

f_b = minimum required freeboard, in metres, determined in accordance with ICLL Reg. 28 as modified by further regulations, as applicable

$$h = 4,6 \text{ m for } \frac{x}{L} \leq 0,75$$

$$= 6,9 \text{ m for } \frac{x}{L} > 0,75$$

11.3.4 Labyrinths, gutter bars or equivalents are to be fitted proximate to the edges of each panel in way of the coamings. The clear profile of these openings is to be kept as small as possible.

11.3.5 Where a hatch is covered by several hatch cover panels, the clear opening of the gap in between the panels is to be not wider than 50 mm.

11.3.6 The labyrinths and gaps between hatch cover panels shall be considered as unprotected openings with respect to the requirements of intact and damage stability calculations.

11.3.7 Bilge alarms are to be provided in each hold fitted with non-weather-tight covers.

11.3.8 Furthermore, Chapter 3 of IMO MSC/Circular.1087 – Guidelines for Partially Weather-tight Hatchway Covers on board Containerships – (Adopted on 18 June 2003) is to be referred to concerning the stowage and segregation of containers containing dangerous goods.

11.4 Omission of hatch covers

11.4.1 Proposals for the omission of hatch covers will be specially considered. Such proposals are to include details, established by model tests or alternative means, of the quantity of water likely to ingress the cargo holds under the worst sea-going and weather conditions, and the means by which it is to be efficiently and safely discharged. The proposals will also require to be agreed by the National Authority in order that an exemption from the Load Line Convention requirements for hatch covers may be obtained.

■ **Section 12**
Strengthening for wave impact loads

12.1 General

12.1.1 The scantlings of plating, stiffeners of forward and after portions of the hull are to be increased for protection against bow flare and wave impact pressure in accordance with Pt 4, Ch 2, 4.3 Strengthening for wave impact loads and Pt 4, Ch 2, 5.2 Strengthening for wave impact loads.

12.1.2 The scantlings of the primary support structure are to be adequate to resist the application of the Rule slamming load, P_{bf} , as defined in Pt 4, Ch 2, 4.2 Bow flare and wave impact pressures 4.2.1, over an area A_{sl} , as shown in Figure 2.5.2 Mean spacing between primary members, S_{cm} , and the extents of wave impact pressure g_{bfh} and g_{bfv} in Pt 4, Ch 2 Ferries, Roll On-Roll Off Ships and Passenger Ships. The loaded area, A_{sl} , is a rectangle with a horizontal extent, g_{bfh} , and vertical extent, g_{bfv} , taken as follows:

$$g_{bfh} = 4 \text{ m}$$

$$g_{bfv} = \frac{8}{\sin \beta_p \sqrt{8K_{bf}}} \text{ m}$$

where

K_{bf} and β_p are given in Pt 4, Ch 2, 4.2 Bow flare and wave impact pressures 4.2.1.

12.1.3 To satisfy *Pt 4, Ch 8, 12.1 General 12.1.2*, the scantlings of web frames supporting side longitudinals or side stringers supporting transverse frames are to comply with the following:

(a) Section modulus not to be less than:

$$Z = 3,75f_{rpc} \gamma_Z k h_s q v l_e^2 \text{ cm}^3$$

(b) Web area not to be less than:

$$A = 0,20f_{rpc} \gamma_A k h_s q v l_e \text{ cm}^2$$

= where

h_s = wave impact head, in metres, as defined in *Pt 4, Ch 2, 4.3 Strengthening for wave impact loads 4.3.2*.

= and

$$f_{rpc} = \frac{P}{3,05V^3}$$

$$= \left(\frac{H}{2,27V^3} \right)$$

P = is the maximum propulsion shaft power in kW for which the machinery is classed, see *Pt 5, Ch 1, 3 Operating conditions*

H = is the maximum propulsion shaft power in HP for which the machinery is classed, see *Pt 5, Ch 1, 3 Operating conditions*

V = is the speed, in knots as defined in *Pt 3, Ch 1, 6 Definitions*

= γ_A and γ_Z are strength factors dependent on the load position:

= for $q < 1$: $\gamma_A = q^3 - 2q^2 + 2$ and $\gamma_Z = 3q^3 - 8q^2 + 6q$

= for $q = 1$: $\gamma_A = 1$, $\gamma_Z = 1$

$$q = \frac{u}{l_e} \text{ but } \leq 1$$

= for web frames

u = is the minimum of g_{biv} or l_e

v = is the minimum of g_{bth} or S_{cm}

= for side stringers

u = is the minimum of g_{bth} or l_e

v = is the minimum of g_{biv} or S_{cm}

l_e = is the effective length of the primary member, in metres

S_{cm} = is the mean spacing between primary members along the plating, in metres, see *Figure 2.5.2 Mean spacing between primary members, S_{cm} , and the extents of wave impact pressure g_{bth} and g_{biv} in Pt 4, Ch 2 Ferries, Roll On-Roll Off Ships and Passenger Ships*

= g_{biv} and g_{bth} are defined in *Pt 4, Ch 8, 12.1 General 12.1.2*

(c) Web plating is to be adequately stiffened to resist shear buckling as required by *Table 8.12.1 Critical shear buckling stress for web plating of primary support structure*.

Table 8.12.1 Critical shear buckling stress for web plating of primary support structure

$\tau_A \leq \tau_{CRB}$ where $\tau_{CRB} = \tau_E \text{ N/mm}^2 \text{ (kgf/mm}^2\text{)} \quad \text{when } \tau_E \leq \frac{\tau_0}{2}$ $\tau_{CRB} = \tau_0 \left(1 - \frac{\tau_0}{4 \tau_E}\right) \text{ N/mm}^2 \text{ (kgf/mm}^2\text{)} \quad \text{when } \tau_E > \frac{\tau_0}{2}$ where $\tau_E = 3,6 \left[1,335 + \left(\frac{s}{1000S}\right)^2\right] E \left(\frac{\tau_p}{s}\right)^2 \text{ N/mm}^2 \text{ (kgf/mm}^2\text{)}$
Symbols
<p>τ_A = design shear stress for the web panel in N/mm² (kgf/mm²) corresponding to the worst combination of application of the slamming load P_{bf} on the patch area A_{sl}</p> <p>τ_{CRB} = critical buckling stress in shear, N/mm² (kgf/mm²) corrected for yielding effects</p> <p>$\tau_0 = \frac{\sigma_0}{\sqrt{3}}$</p> <p>$\sigma_0$ = specified minimum yield stress, in N/mm² (kgf/mm²)</p> <p>τ_E = elastic critical buckling stress in shear, in N/mm² (kgf/mm²)</p> <p>s = length of longer panel edge, in mm (generally the spacing of web stiffeners)</p> <p>S = length of smaller panel edge, in metres (generally the web depth)</p> <p>E = modulus of elasticity, in N/mm² (kgf/mm²) = 206000 N/mm² (21000 kgf/mm²) for steel</p> <p>τ_p = as built thickness of primary member web plating, in mm</p>

■ *Section 13*
Container stowage systems

13.1 Cell guide systems

13.1.1 Where cell guide systems are fitted to support containers in holds or on deck, they are to comply with the requirements of Pt 3, Ch 14, 7 Container securing arrangements for stowage using cell guides.

13.2 Stowage on decks/hatch covers

13.2.1 Strength of support structures for pads/pedestals under container corners, lashing equipment and lashing bridges is to comply with *Pt 3, Ch 14, 4 Ship structure*.

13.3 Ergonomic container lashing

13.3.1 A ship designed to carry containers that is provided with safe access and securing arrangements in accordance with the *Provisional Rules for Ergonomic Container Lashing, December 2014* will be eligible to be assigned the special features notation **ECL** (Ergonomic Container Lashing), with supplementary descriptor.

■ Section 14

Direct calculation**14.1 Procedures for calculation of combined longitudinal and torsional strength**

14.1.1 For container ships as defined in *Pt 4, Ch 8, 1.3 Class notations 1.3.3*, longitudinal strength calculations are to be made in accordance with Parts A and B of LR's ShipRight SDA Procedure for container ships, see also *Table 8.14.1 Summary of direct calculation analysis requirements for container ships*

14.1.2 The global, primary and local structure scantlings are to be assessed using the vertical and horizontal wave bending moments and shear forces and torsional wave moments derived using non-linear ship motion analysis based on equivalent design sea state methods where one or more of the following conditions applies:

- (a) $B > 60$ m
- (b) $L > 425$ m

The methodology to calculate the non-linear ship motion wave loads is given in LR's ShipRight Procedure *Guidance Notes on the Assessment of Global Design Loads of Large Container Ships and Other Ships Prone to Whipping and Springing*.

14.2 Procedures for verification of primary structure scantlings

14.2.1 For container ships as defined in *Pt 4, Ch 8, 1.3 Class notations 1.3.3*, the strength of the ship's primary structure scantlings of double bottom, side and transverse bulkheads is to be assessed in accordance with Part C of LR's ShipRight SDA Procedure for container ships. The wave loads to be applied in this assessment are to be calculated in accordance with *Pt 4, Ch 8, 3.2 Longitudinal strength*.

14.2.2 For other container ships the method for analysis of primary structure of double bottom, side structure and transverse bulkheads is to be agreed with LR.

14.3 Procedures for verification of structural response due to whipping, springing and fatigue

14.3.1 The ShipRight notation **WDA** is mandatory for container ships when one or more of the following conditions applies, and where the ultimate strength of the hull girder is assessed against the extreme wave bending moments including whipping and wave impact loads in accordance with LR's ShipRight Procedure *Guidance Notes on the Assessment of Global Design Loads of Large Container Ships and Other Ships Prone to Whipping and Springing*:

- (a) $L > 350$ m
- (b) $L > 300$ m and one or more of
 - (i) $|f_{\text{fs}}| > 1,4$ or
 - (ii) $RA_{\text{BF}} > 0,2$ or
 - (iii) $RA_{\text{BFU}} > 0,2$
- (c) Use of HT47 or above for the deck or hatch side coaming
- (d) Use of HT36 or above for the bottom shell

Where

f_{fs} = is defined in *Pt 4, Ch 2, 2.4 Design vertical wave bending moments 2.4.1*

RA_{BF} and RA_{BFU} = are defined in Pt 4, Ch 8, 3.2 Longitudinal strength 3.2.3

See Table 8.14.1 Summary of direct calculation analysis requirements for container ships.

Table 8.14.1 Summary of direct calculation analysis requirements for container ships

Rule requirement See Note 1	Rule reference	ShipRight notation	Application criteria. If any of the following criteria apply then the appropriate analysis is required					
			Length criteria	Any of $ f_{IS} > 1,4$ or $RA_{BF} > 0,2$ or $RA_{BFU} > 0,2$	$f_c > f_{sp}$	Deck or hatch side coaming steel grade \geq HT47	Bottom steel grade \geq HT36	Breadth criteria
LR's ShipRight SDA Procedure for container ships	Pt 4, Ch 8, 1.3 Class notations 1.3.3	SDA	—	—	—	—	—	$B > 32$
Non-linear ship motion analysis to calculate hogging and sagging factors	Pt 4, Ch 8, 3.2 Longitudinal strength 3.2.3	—	—	$L > 300$	—	—	—	—
Non-linear ship motion analysis to calculate combined vertical, horizontal and torsional loads	Pt 4, Ch 8, 14.1 Procedures for calculation of combined longitudinal and torsional strength 14.1.2	—	$L > 425$	—	—	—	—	$B > 60$
Fatigue assessment	Pt 4, Ch 8, 14.3 Procedures for verification of structural response due to whipping, springing and fatigue 14.3.2	FDA (see Note 3)	$L > 350$	—	$L > 250$	Yes	Yes	—
Whipping assessment	Pt 4, Ch 8, 14.3 Procedures for verification of structural response due to whipping, springing and fatigue 14.3.1	WDA	$L > 350$	$L > 300$	—	Yes	Yes	—

Springing assessment See Note 2	<i>Pt 4, Ch 8, 14.3 Procedures for verification of structural response due to whipping, springing and fatigue 14.3.2</i>	FDA SPR	$L > 350$	—	$L > 250$	Yes	Yes	—
<p>Note 1 The stated rule requirements may be deemed applicable to ships that do not meet the application criteria but where the structural configuration is such as to necessitate them.</p> <p>Note 2 The results of the springing assessment may also need a fatigue assessment procedure to be undertaken.</p> <p>Note 3 If ShipRight notation FDA is to be assigned, the requirements of LR's ShipRight FDA procedure are to be complied with; this may require calculations additional to those implied by <i>Pt 4, Ch 8, 14.3 Procedures for verification of structural response due to whipping, springing and fatigue 14.3.2</i>.</p>								

14.3.2 The ShipRight notation **FDA SPR** is mandatory for container ships when one or more of the following conditions applies, and where the fatigue performance of the hull girder taking into account the effects from springing, is assessed in accordance with LR's ShipRight Procedure *Guidance Notes on the Assessment of Global Design Loads of Large Container Ships and Other Ships Prone to Whipping and Springing*:

- (a) $L > 350$ m
- (b) $L > 250$ m and $f_c > f_{sp}$
- (c) Use of HT47 or above for the deck or hatch side coaming
- (d) Use of HT36 or above for the bottom shell

Where

(a) f_c = is a wave encounter frequency at which it is expected that springing will become important

$$= \frac{1,4}{2\pi} \left(1 + \frac{1,4V}{2g} \right) \text{Hz}$$

f_{sp} = is the natural frequency of the 2 node hull girder vertical bending mode in Hz. This can be very approximately calculated as:

$$= \left(\frac{1,1}{\pi L^2} \right) \sqrt{\frac{EI10^5}{1,8BT_d C_b}} \text{Hz}$$

V = speed in knots as defined in *Pt 3, Ch 1, 6.1 Principal particulars 6.1.10*

E = Young's modulus in N/mm²

= 206000 N/mm² for steel

I = is the midship moment of inertia in m⁴, see *Pt 3, Ch 4 Longitudinal Strength*

T_d = is the design (normal standard operating) draught, in metres.

C_b , L , and B are given in *Pt 3, Ch 1, 6 Definitions*.

The fatigue assessment is to be carried out in accordance with LR's ShipRight Procedure *Guidance Notes on the Assessment of Global Design Loads of Large Container Ships and Other Ships Prone to Whipping and Springing*, which also makes reference to LR's ShipRight FDA procedures.

■ *Section 15*
Requirements for ships with large deck openings

15.1 Application

15.1.1 The combined stresses due to vertical bending moment, horizontal bending moment and torque are to be calculated as described in this Section.

15.2 Symbols and definitions

15.2.1 The following symbols and definitions are applicable to this Section unless otherwise stated:

Z_Y = actual hull section modulus about the transverse neutral axis at the position considered, in m^3

Z_Z = actual hull section modulus about the vertical neutral axis at the position considered, in m^3

ε = shear centre distance below baseline, may be taken as the maximum shear centre distance below baseline of the ship in the midship region, in metres. ε is taken as positive where the shear centre is below the baseline

M_S = design still water bending moment at the section under consideration, in kN m (tonne-f-m)

σ_C = combined stress at the position considered.

15.3 Design loadings

15.3.1 The design vertical wave bending moments, M_{WC1} and M_{WC2} , at any position along the ship is defined as:

$$M_{WC1} = 0,0505C_0 C_{31} L^2 B (C_b + 0,7) \text{ kN m}$$

$$= (0,0052 C_0 C_{31} L^2 B (C_b + 0,7) \text{ tonne-f-m})$$

$$M_{WC2} = 0,0505C_0 C_{32} L^2 B (C_b + 0,7) \text{ kN m}$$

$$= (0,0052 C_0 C_{32} L^2 B (C_b + 0,7) \text{ tonne-f-m})$$

C_{31}, C_{32} = vertical wave bending moment distribution coefficients depending on the longitudinal position from A.P. as defined in *Table 8.15.1 Distribution of wave bending moments*

$$C_0 = 11,65 \left(0,6 + 0,0942 \left(\frac{L}{100} - 1 \right) \right)$$

L, B, C_b are given in *Pt 3, Ch 1, 6 Definitions*.

The sign convention is given in *Figure 8.15.1 Sign conventions for hull girder loads*

Table 8.15.1 Distribution of wave bending moments

Position		C_{31}	C_{32}
Station	0 (A.P.)	0,000	0,000
	1	0,062	0,018
	2	0,158	0,017
	3	0,305	-0,008
	4	0,460	-0,058
	5	0,611	-0,137

6	0,732	-0,235
7	0,817	-0,350
8	0,850	-0,458
9	0,836	-0,548
10 (mid – L_{pp})	0,780	-0,607
11	0,683	-0,615
12	0,555	-0,571
13	0,415	-0,498
14	0,275	-0,404
15	0,165	-0,302
16	0,085	-0,208
17	0,041	-0,132
18	0,022	-0,074
19	0,010	-0,028
20 (F.P.)	0,000	-0,000

Note Intermediate values are to be determined by linear interpolation.

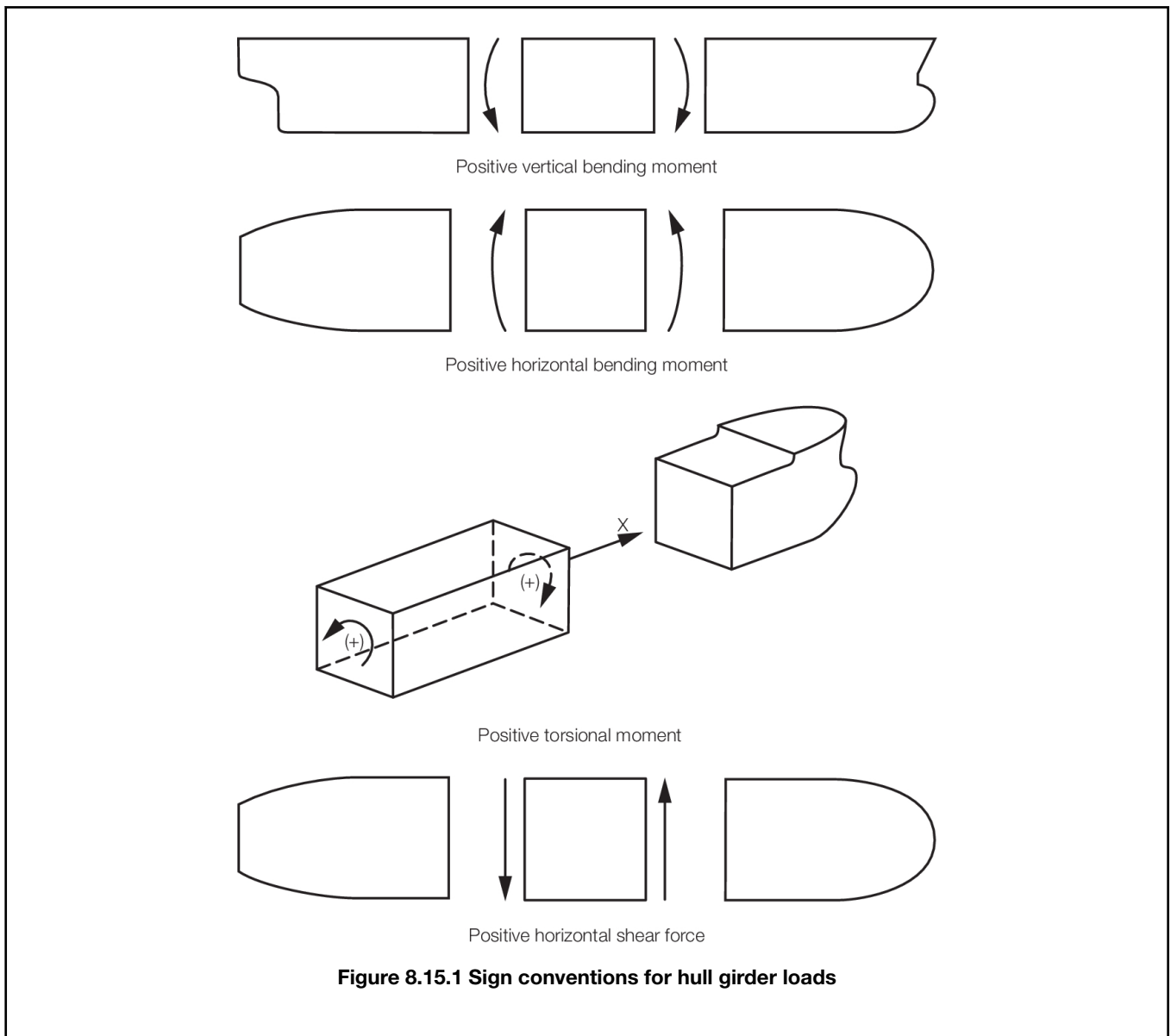

15.3.2 The design horizontal wave bending moments, M_{HC1} and M_{HC2} , at any position along the ship are defined as:

$$M_{HC1} = 0,2063C_0 C_{41} L^2 T (C_b + 0,7) \text{ kN m}$$

$$= (0,0210C_0 C_{41} L^2 T (C_b + 0,7) \text{ tonne-f-m})$$

$$M_{HC2} = 0,2063C_0 C_{42} L^2 T (C_b + 0,7) \text{ kN m}$$

$$= (0,0210C_0 C_{42} L^2 T (C_b + 0,7) \text{ tonne-f-m})$$

C_{41}, C_{42} = horizontal wave bending moment distribution coefficients depending on the longitudinal position from A.P. as defined in *Table 8.15.2 Distribution of horizontal wave bending moments and hydrodynamic torques*

C_0 is defined in Pt 4, Ch 8, 15.3 Design loadings 15.3.1

L, T, C_b are given in Pt 3, Ch 1, 6 Definitions.

The sign convention is given in *Figure 8.15.1 Sign conventions for hull girder loads*.

Table 8.15.2 Distribution of horizontal wave bending moments and hydrodynamic torques

Position	C_{41}	C_{42}	C_{51}	C_{52}	K_{31}	K_{32}
Station 0 (A.P.)	0,000	0,000	0,000	0,000	0,000	0,000
1	-0,016	0,010	-0,289	0,235	0,101	-0,113
2	-0,046	0,046	-0,456	0,525	0,211	-0,304
3	-0,097	0,119	-0,455	0,754	0,276	-0,486
4	-0,154	0,228	-0,342	0,910	0,277	-0,659
5	-0,208	0,369	-0,184	0,988	0,214	-0,804
6	-0,242	0,533	-0,022	1,000	0,089	-0,860
7	-0,247	0,699	0,169	0,944	-0,083	-0,801
8	-0,217	0,846	0,323	0,851	-0,268	-0,662
9	-0,153	0,948	0,439	0,727	-0,422	-0,404
10 (mid - L_{pp})	-0,072	0,997	0,522	0,585	-0,485	-0,090
11	0,014	0,985	0,562	0,443	-0,447	0,232
12	0,087	0,915	0,544	0,288	-0,338	0,483
13	0,136	0,802	0,472	0,111	-0,227	0,734
14	0,158	0,657	0,260	-0,011	-0,094	0,913
15	0,151	0,502	-0,074	-0,121	0,067	0,998
16	0,123	0,349	-0,366	-0,082	0,185	0,952
17	0,083	0,214	-0,385	0,039	0,245	0,821
18	0,043	0,106	-0,198	0,062	0,220	0,627
19	0,013	0,034	-0,075	0,052	0,133	0,326
20 (F.P.)	0,000	0,000	0,000	0,000	0,000	0,000

Note Intermediate values are to be determined by linear interpolation.

15.3.3 The design hydrodynamic torques, M_{WTC1} and M_{WTC2} , at any position along the ship are defined as:

$$M_{WTC1} = M_{WTCB1} + M_{WTCQ1}$$

$$M_{WTCB1} = 0,0728C_0 C_{51} L B^2 (C_b + 0,7) \text{ kN m}$$

$$= (0,0074C_0 C_{51} L B^2 (C_b + 0,7) \text{ tonne-f-m})$$

$$M_{WTCQ1} = -(0,65T + \varepsilon) Q_{HC1} \text{ kN m (tonne-f-m)}$$

$$M_{WTC2} = M_{WTCB2} + M_{WTCQ2}$$

$$M_{WTCB2} = 0,0728C_0 C_{52} L B^2 (C_b + 0,7) \text{ kN m}$$

$$= (0,0074C_0 C_{52} L B^2 (C_b + 0,7) \text{ tonne-f-m})$$

$$M_{WTCQ2} = -(0,65T + \varepsilon) Q_{HC2} \text{ kN m (tonne-f-m)}$$

C_{51} , C_{52} = hydrodynamic torque distribution coefficients depending on the longitudinal position from A.P. as defined in Table 8.15.2 Distribution of horizontal wave bending moments and hydrodynamic torques

C_0 is defined in Pt 4, Ch 8, 15.3 Design loadings 15.3.1

$$Q_{HC1} = 0,8683C_0 K_{31} L T (C_b + 0,7) \text{ kN}$$

$$= (0,0886C_0 K_{31} L T (C_b + 0,7) \text{ tonne-f})$$

$$Q_{HC2} = 0,8683C_0 K_{32} L T (C_b + 0,7) \text{ kN}$$

$$= (0,0886C_0 K_{32} L T (C_b + 0,7) \text{ tonne-f})$$

K_{31}, K_{32} = horizontal wave shear force distribution coefficients depending on the longitudinal position from A.P. as defined in Table 8.15.2 Distribution of horizontal wave bending moments and hydrodynamic torques

L, B, T, C_b , are given in Pt 3, Ch 1, 6 Definitions.

ϵ is given in Pt 4, Ch 8, 15.2 Symbols and definitions 15.2.1

The sign convention is given in Figure 8.15.1 Sign conventions for hull girder loads.

15.3.4 The design value of static cargo torque, M_{STC} , at any position along the ship is defined as:

$$M_{STC} = 15,7C_6 B (\eta_s \eta_t + 0,7N_{sd} N_{td}) \text{ kNm}$$

$$= (1,6C_6 B (\eta_s \eta_t + 0,7N_{sd} N_{td}) \text{ tonne-f/m})$$

η_s = the maximum number of stacks of containers over the breadth of the cargo hold

η_t = the maximum number of tiers of containers in the cargo hold amidships, excluding containers above the main deck or on the hatch covers

C_6 = distribution coefficient depending on the length, L_{pp} , as defined in Table 8.15.3 Static cargo torque distribution factor

N_{sd} = the maximum number of stacks of containers over the breadth, B , on hatch covers or above the main deck

N_{td} = the number of tiers of containers on hatch covers or above the main deck amidships, excluding containers in cargo holds

B is given in Pt 3, Ch 1, 6 Definitions.

Table 8.15.3 Static cargo torque distribution factor

Position	Factor C_6
Station 0 (A.P.)	0,0
5	1,0
15	1,0
20 (F.P.)	0,0
Note Intermediate values are to be determined by linear interpolation.	

15.4 Combined stress

15.4.1 Combined stress calculations are to be carried out at least at the following positions along the length of the ship:

- (a) At the forward and aft ends of the engine room.
- (b) At the forward and aft ends of the deck-house for multi-island designs.
- (c) At the forward and aft transverse bulkhead positions of each cargo bay.

- (d) At the forward and aft transverse bulkhead of fuel oil deep tanks.
- (e) At any other sections where there are significant changes in cross-section properties.

15.4.2 The combined stress, σ_c , is to be less than the permissible stress given in *Table 8.15.4 Permissible stress*. σ_c is to be taken as the greatest magnitude of the following stresses:

$$\sigma_{c1} = \sqrt{(\sigma_1 - (1-f)\sigma_{WC1})^2 + (\sigma_2 - (1-f)\sigma_{WC2})^2} + \sigma_{SC} + |\sigma_{STC}|$$

$$\sigma_{c2} = -\sqrt{(\sigma_1 - (1-f)\sigma_{WC1})^2 + (\sigma_2 - (1-f)\sigma_{WC2})^2} + \sigma_{SC} + |\sigma_{STC}|$$

$$\sigma'_{c1} = \sqrt{(\sigma'_1 - (1-f)\sigma_{WC1})^2 + (\sigma'_2 - (1-f)\sigma_{WC2})^2} + \sigma_{SC} - |\sigma_{STC}|$$

$$\sigma'_{c2} = -\sqrt{(\sigma'_1 - (1-f)\sigma_{WC1})^2 + (\sigma'_2 + (1-f)\sigma_{WC2})^2} + \sigma_{SC} - |\sigma_{STC}|$$

where

$$\sigma_1 = \sigma_{WC1} + \sigma_{HC1} + \sigma_{WTC1}$$

$$\sigma_2 = \sigma_{WC2} + \sigma_{HC2} + \sigma_{WTC2}$$

$$\sigma'_1 = \sigma_{WC1} - \sigma_{HC1} - \sigma_{WTC1}$$

$$\sigma'_2 = \sigma_{WC2} - \sigma_{HC2} - \sigma_{WTC2}$$

For σ_{c1}

$$f = |f_{fH}| \text{ if } M_{WC} \geq 0, f = |f_{fS}| \text{ if } M_{WC} < 0$$

$$f = |f_{fH}| \text{ if } M_{WC} \leq 0, f = |f_{fS}| \text{ if } M_{WC} > 0$$

where

$$M_{WC} = M_{WC1} \frac{\sigma_1}{\sqrt{\sigma_1^2 + \sigma_2^2}} + M_{WC2} \frac{\sigma_2}{\sqrt{\sigma_1^2 + \sigma_2^2}}$$

For σ'_{c1}

$$f = |f_{fH}| \text{ if } M_{WC}' \geq 0, f = |f_{fS}| \text{ if } M_{WC}' < 0$$

For σ'_{c2}

$$f = |f_{fH}| \text{ if } M_{WC}' \leq 0, f = |f_{fS}| \text{ if } M_{WC}' > 0$$

where

$$M_{WC}' = M_{WC1} \frac{\sigma'_1}{\sqrt{\sigma'_1^2 + \sigma'_2^2}} + M_{WC2} \frac{\sigma'_2}{\sqrt{\sigma'_1^2 + \sigma'_2^2}}$$

σ_{SC} = longitudinal stress due to hogging or sagging design still water bending moment M_s

$\sigma_{WC1}, \sigma_{WC2}$ = longitudinal stress due to vertical wave bending moments

$\sigma_{HC1}, \sigma_{HC2}$ = longitudinal stress due to horizontal wave bending moments

σ_{STC} = longitudinal warping stress due to static cargo torque

$\sigma_{WTC1}, \sigma_{WTC2}$ = longitudinal warping stress due to hydrodynamic torques

f_{fH}, f_{fS} = hogging and sagging vertical bending moment correction factors calculated in accordance with Pt 4, Ch 2, 2.4 Design vertical wave bending moments and Pt 4, Ch 2, 3.2 Deck plating 3.2.3

M_{WC1}, M_{WC2} = vertical bending moments defined in Pt 4, Ch 8, 15.3 Design loadings 15.3.1 at the longitudinal position considered

other symbols are as defined in Pt 4, Ch 8, 15.3 Design loadings and Pt 4, Ch 8, 15.4 Combined stress.

15.4.3 For ships with a beam greater than 32 m, longitudinal stresses are to be calculated using a finite element model of the entire hull in accordance with Part A of the LR's ShipRight SDA procedure for container ships.

15.4.4 For ships with a beam less than or equal to 32 m, the longitudinal stresses may be obtained as follows:

$$\sigma_{SC} = \frac{M_s}{Z_y} \times 10^{-3} \text{ N/mm}^2 (\text{kgf/mm}^2)$$

$$\sigma_{WC} = \frac{M_{WC}}{Z_y} \times 10^{-3} \text{ N/mm}^2 (\text{kgf/mm}^2)$$

$$\sigma_{HC1} = C \frac{M_{HC1}}{Z_z} \times 10^{-3} \text{ N/mm}^2 (\text{kgf/mm}^2)$$

$$\sigma_{HC2} = C \frac{M_{HC2}}{Z_z} \times 10^{-3} \text{ N/mm}^2 (\text{kgf/mm}^2)$$

$\sigma_{WTC1}, \sigma_{WTC2}$ and σ_{STC} are to be evaluated by approved calculation procedures.

C_7 = coefficient for shear lag depending on vertical location of the point under consideration

= 0,6 at inboard edge of strength deck

= 1,0 at base line

= intermediate positions by interpolation

Z_y and Z_z are given in Pt 4, Ch 8, 15.2 Symbols and definitions 15.2.1.

15.4.5 At each section the stresses are to be calculated on the port and starboard sides, at:

- (a) the inboard edge of the strength deck;
- (b) the point on the bilge where the combined stress is greatest; and
- (c) the top of continuous hatch coaming (where fitted).

15.4.6 Where the ship's length is greater than 425 m or the ship's beam is greater than 60 m, the vertical wave bending moments, horizontal wave bending moments and hydrodynamic torques are to be obtained from a direct calculation method. Alternatively, the hull stresses may be obtained using a probabilistic approach response-based analysis method considering the ship's responses in wave environment. The analysis method is to be agreed with LR.

15.5 Permissible stress

15.5.1 The maximum tensile or compressive combined stress σ_c at any position along the length is not to be more than indicated in Table 8.15.4 Permissible stress.

Table 8.15.4 Permissible stress

Position	Permissible combined stress, N/mm ² (kgf/mm ²)
Top of continuous hatch coaming	$\sigma_c = \frac{175}{k_L} \left(\frac{17,84}{k_L} \right)$
Elsewhere	$\sigma_c = \frac{157}{k_L} \left(\frac{16,0}{k_L} \right)$

15.5.2 The assessment of combined stress may conveniently be presented in the form of combined stress diagrams as indicated in *Figure 8.15.2 Combined stress diagram for deck - Oblique sea*.

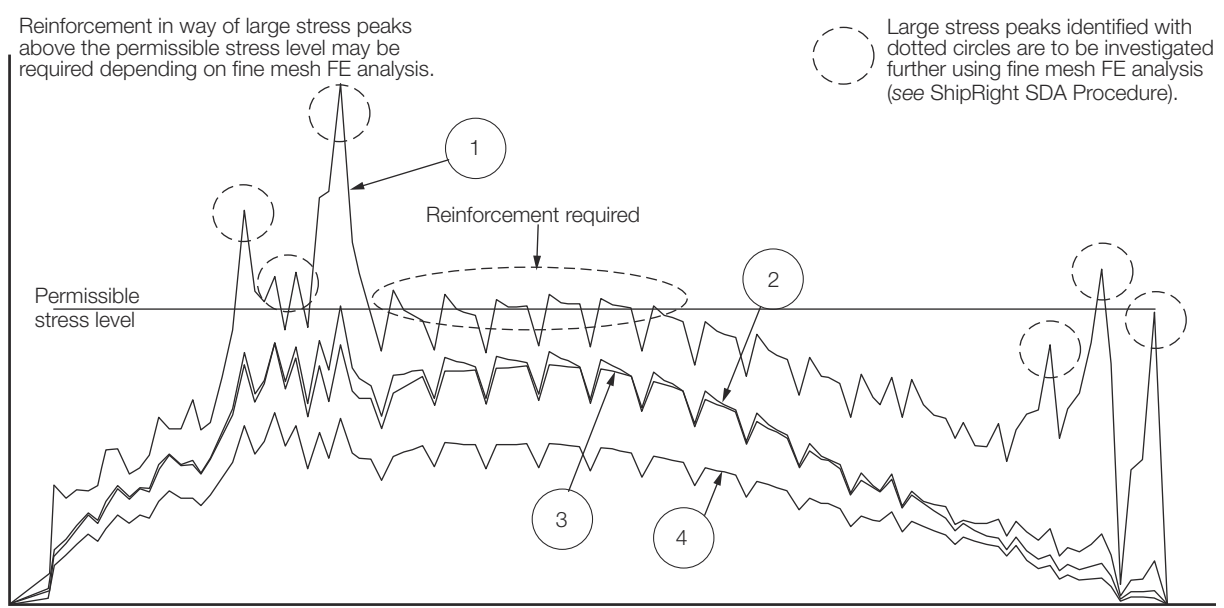

- (a) Longitudinal stress distributions at top of hatch coaming showing contributions from:
- 1) still water bending moment + vertical wave bending moment + static cargo torque + horizontal wave bending moment and hydrodynamic torque
 - 2) still water bending moment + vertical wave bending moment + static cargo torque
 - 3) still water bending moment + vertical wave bending moment
 - 4) still water bending moment

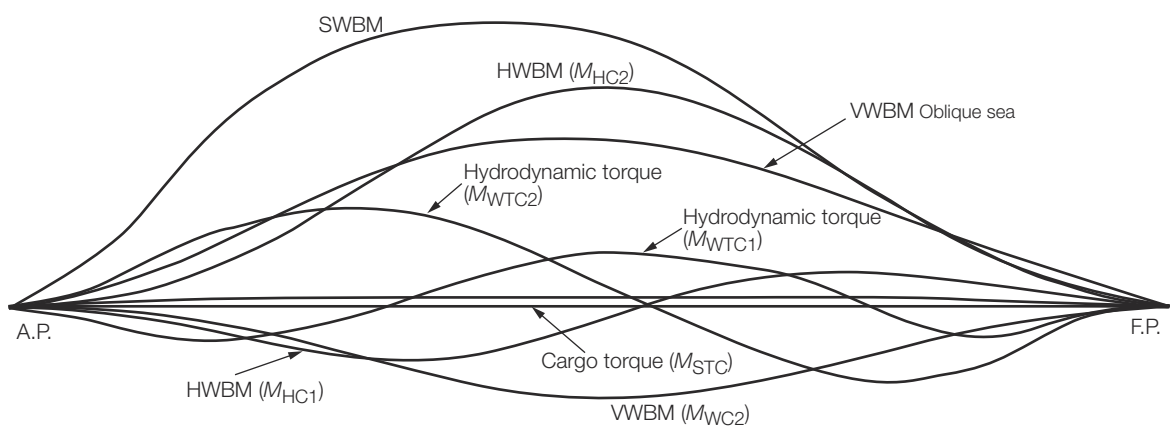
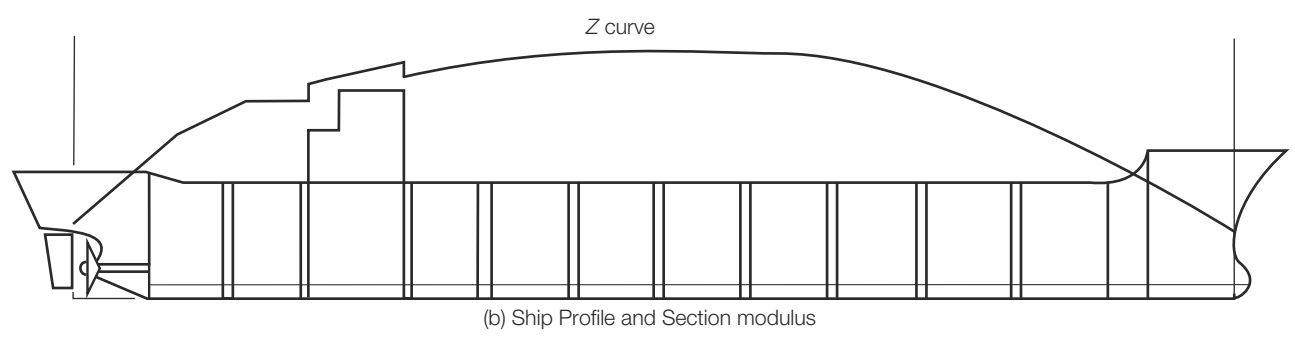

(c) Oblique Sea longitudinal distribution of vertical and horizontal bending moments and torques

- NOTES
1. These diagrams are for illustration only and are not to scale.
 2. A similar diagram is to be prepared for the bottom structure.

Figure 8.15.2 Combined stress diagram for deck - Oblique sea

Section

- 1 **General**
- 2 **Materials and protection**
- 3 **Longitudinal strength**
- 4 **Hull envelope plating**
- 5 **Hull framing**
- 6 **Inner hull, inner bottom and longitudinal oiltight bulkheads**
- 7 **Transverse oiltight bulkheads**
- 8 **Non-oiltight bulkheads**
- 9 **Primary members supporting longitudinal framing**
- 10 **Construction details and minimum thickness**
- 11 **Ships for alternate carriage of oil cargo and dry bulk cargo**
- 12 **Cargo temperatures**
- 13 **Access arrangements and closing appliances**
- 14 **Direct calculations**

■ Section 1 General

1.1 General

1.1.1 This Chapter applies primarily to the arrangements and scantlings within the cargo tank region of sea-going tankers having integral cargo tanks, for the carriage of oil having a flash point not exceeding 60°C (closed-cup test), in association with the class notation indicated in *Pt 4, Ch 9, 1.3 Class notation and applicable Rules for CSR Double Hull Oil Tankers 1.3.1* or *Pt 4, Ch 9, 1.4 Class notation and applicable Rules for non-CSR Double Hull Oil Tankers 1.4.1*. Except as indicated in *Pt 4, Ch 9, 1.1 General 1.1.2, Pt 4, Ch 9, 1.1 General 1.1.3* and *Pt 4, Ch 9, 1.1 General 1.1.4*, the cargo spaces are to be bounded by side and bottom dedicated water ballast tanks or void spaces constituting a double hull for the ship, see *Table 9.1.1 Cargo tank boundary requirements*.

1.1.2 Double side tanks may be dispensed with for tankers of less than 5000 tonnes deadweight where each cargo tank capacity does not exceed 700 m³, see *Table 9.1.1 Cargo tank boundary requirements*.

1.1.3 Double bottom tanks may be dispensed with for tankers of 5000 tonnes deadweight or greater subject to compliance with the requirements of *Pt 4, Ch 9, 1.2 Application and ship arrangement 1.2.18*.

1.1.4 Double bottoms and double sides may be dispensed with for vessels less than 600 tonnes deadweight, see *Table 9.1.1 Cargo tank boundary requirements*.

1.1.5 Where only oils having flash points exceeding 60°C are to be carried, the Rule requirements and class notation will be modified accordingly the additional class notation 'F.P. exceeding 60°C' will be entered in the *Register Book*.

1.1.6 Oil cargoes listed in *Table 9.1.2 Oil cargoes suitable for carriage in oil tankers, see Note 1* are those which are generally envisaged as being carried in ships classed in accordance with this Chapter.

1.1.7 The scantlings and arrangements of tankers intended for cargoes other than oil will be specially considered in relation to the characteristics of the cargo, and the class notation will be modified accordingly. A full list of such cargoes for a particular ship, with special requirements as applicable, can be provided by Lloyd's Register (hereinafter referred to as 'LR') on application. Chemical cargoes listed in *Chapter 18 of the Rules and Regulations for the Construction and Classification of Ships for the*

Double Hull Oil Tankers

Part 4, Chapter 9

Section 1

Carriage of Liquid Chemicals in Bulk (hereinafter referred to as the Rules for Ships of Liquid Chemicals) may be carried in ships for which the arrangements, scantlings and materials comply with the requirements of that Chapter. Special consideration will also be given to the carriage of cargoes with a relative density greater than 1,025, see also Pt 4, Ch 9, 1.3 Class notation and applicable Rules for CSR Double Hull Oil Tankers and Pt 4, Ch 9, 1.4 Class notation and applicable Rules for non-CSR Double Hull Oil Tankers.

1.1.8 The Regulations for classification and assignment of the above notations and other notations, as appropriate to the arrangements, scantlings and service are provided for in Pt 1, Ch 2, 2 Character of classification and class notations.

Table 9.1.1 Cargo tank boundary requirements

Deadweight (DWT) tonnes	Minimum double side width (d_s) metres	Minimum double bottom depth (d_b) metres
DWT \geq 5000	$d_s = 0,5 + \frac{DWT}{20\,000}$ or $d_s = 2,0$ whichever is the lesser, but not less than 1,0	$d_b = \frac{B}{15}$ or $d_b = 2,0$ whichever is the lesser, but not less than 1,0
600 \leq DWT < 5000	$d_s = 0,4 + \frac{2,4DWT}{20\,000}$ or $d_s = 0,76$ whichever is the greater, see Note 2	$d_b = \frac{B}{15}$ or $d_b = 0,76$ whichever is the greater,
DWT < 600	$d_s = 0$	$d_b = 0$
<p>Note 1. The symbols <i>DWT</i>, d_s and d_b are defined in 1.5.</p> <p>Note 2. Where each cargo tank capacity does not exceed 700 m³, the value of d_s is taken as 0 and the inner bottom line is to run parallel to the line of the midship flat of bottom as shown in Figure 9.1.2 Cargo tank boundary lines for oil tankers having double bottom arrangement (See) .</p> <p>Note 3. Where the double bottom tank is fitted, the centre girder depth is to be not less than as required by Pt 4, Ch 9, 9.3 Girders and floors in double bottom 9.3.3.</p>		

Table 9.1.2 Oil cargoes suitable for carriage in oil tankers, see Note 1

Asphalt solutions (see Note 2)	Gasoline Blending Stocks
Blending Stocks	Alkylates – fuel
Roofers Flux	Reformats
Straight Run Residue	Polymer – fuel
Oils	Gasolines
Clarified	Casinghead (natural)
Crude Oil	Automotive
Mixtures containing crude oil	Aviation Straight Run
Diesel Oil	Fuel Oil No. 1 (Kerosene)
Fuel Oil No. 4	Fuel Oil No. 1-D
Fuel Oil No. 5	Fuel Oil No. 2
Fuel Oil No. 6	Fuel Oil No. 2-D

Residual Fuel Oil	
Road Oil	Jet Fuels
Transformer Oil	JP-1 (Kerosene)
Lubricating Oils and Blending Stocks	JP-3 JP-4
Mineral Oil	JP-5 (Kerosene, Heavy)
Motor Oil	Turbo Fuel
Penetrating Oil	Kerosene
Spindle Oil	Mineral Spirit
Turbine Oil	
	Naphtha (see Note 3)
Distillates	Solvent
Straight Run	Petroleum
Flashed Feed Stocks	Heartcut Distillate Oil
Gas Oil	
Cracked	
<p>Note 1. This list of oils is taken from Appendix 1 to Annex 1 of the MARPOL Convention. Special consideration will be given to the carriage of oil cargoes not included in the above list.</p> <p>Note 2. Asphalt solutions, see Chapter 18 of the Rules for Ships for Liquid Chemicals.</p> <p>Note 3. For naphtha coal tar and naphthalene molten, see Chapter 17 of the Rules for Ships for Liquid Chemicals.</p>	

1.2 Application and ship arrangement

1.2.1 Double hull tankers with length, L , greater than or equal to 150 m with structural configuration as shown in Table 9.1.3 Structural arrangement are defined as 'CSR Oil Tankers' and are to comply with Pt 4, Ch 9, 1.3 Class notation and applicable Rules for CSR Double Hull Oil Tankers.

1.2.2 The applicable Rules for double hull tankers with length, L , greater than or equal to 150 m of unusual hull form or structural arrangements will be specially considered.

1.2.3 Double hull tankers with length, L , less than 150 m are defined as 'Non-CSR Oil Tankers' and are to comply with Pt 4, Ch 9, 1.4 Class notation and applicable Rules for non-CSR Double Hull Oil Tankers.

1.2.4 Any dry tanks, or tanks intended for water ballast and thus empty in the loaded condition, are to be so arranged that they cannot be used for any other purpose.

1.2.5 Cofferdams are to be provided at the forward and after ends of the oil cargo spaces; cofferdams are to be at least 760 mm in length and are to cover the whole area of the end bulkheads of the cargo spaces.

1.2.6 A pump-room, fuel oil bunker or water ballast tank will be accepted in lieu of a cofferdam.

Double Hull Oil Tankers

Part 4, Chapter 9

Section 1

Table 9.1.3 Structural arrangement

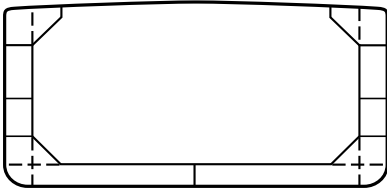
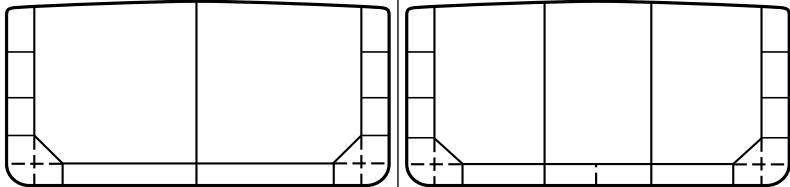
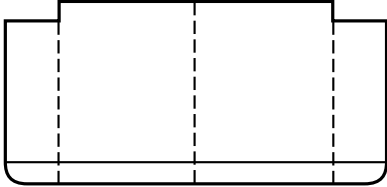
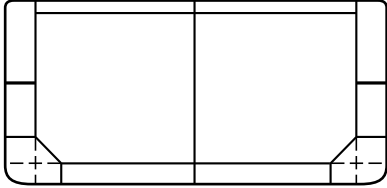
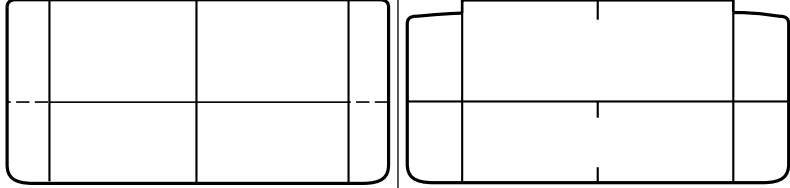
Arrangement	Typical configuration	L < 150	L ≥ 150
No longitudinal bulkhead		Non CSR	CSR (specially considered)
One or two longitudinal bulkhead(s)		Non CSR	CSR
Trunk deck in association with longitudinal bulkhead(s) (see Ch 10,6)		Non CSR	CSR
Double deck in association with a centreline bulkhead		Non CSR	CSR (specially considered)
Mid-deck in association with a centreline bulkhead or centreline girders		Non CSR	CSR (specially considered)

1.2.7 Where the lower portion of the pump-room is recessed into the machinery space, the height of the recess is not, in general, to exceed one-third of the moulded depth above the keel, see also Pt 5, Ch 15, 1 General requirements.

1.2.8 Where a compartment or tank, such as a fore peak tank, forms a cofferdam, access is to be from the open deck. Alternatively, any space through which it is necessary to pass in order to obtain access is to conform to the requirements of Pt 6, Ch 2, 14 Electrical equipment for use in explosive gas atmospheres or in the presence of combustible dusts. Oil engine or electrically driven pumps are not to be sited in the space containing the access to such cofferdams.

1.2.9 A cofferdam is also to be arranged between a cargo oil tank and accommodation spaces, and between cargo oil tanks and spaces containing electrical equipment, other than spaces where the only items of electrical equipment are lighting fittings complying with Pt 6, Ch 2, 14 Electrical equipment for use in explosive gas atmospheres or in the presence of combustible dusts. Where a corner to corner situation occurs, protection may be formed by a diagonal plate across the corner. The scantlings and testing arrangements are to comply with Rule requirements for cofferdam bulkheads, and arrangements are to be made to enable the space to be filled with water ballast to assist in gas freeing, see also Pt 5, Ch 15, 3 Cargo handling system. Suitable corrosion protection, drainage and gas-freeing arrangements are to be provided to such spaces.

1.2.10 Passages or tunnels passing through, or adjacent to, a cargo oil tank and not separated from it by a cofferdam, are to be provided with mechanical ventilation, and any access is to be from the open deck.

1.2.11 Arrangements are to be provided to enable double bottom and vertical wing tanks to be filled with water ballast to assist in gas freeing these tanks, see Pt 5, Ch 15, 3 Cargo handling system.

- 1.2.12 Fittings within cargo tanks and pump-rooms are to be securely fastened to the structure.
- 1.2.13 Accommodation, control and service spaces are to be located clear of the cargo tank region such that a single failure of deck or bulkhead will not allow cargo fumes into these spaces. Navigation positions, where fitted above the cargo tank region, are to be separated from the cargo tank deck by means of an open space with a height of at least 2,0 m.
- 1.2.14 Where spill retention flats are fitted at the sides of the weather deck, separate arrangements are to be provided for freeing the deck of oil and water respectively, see also Pt 3, Ch 10, 5.1 Continuity and alignment 5.1.1.
- 1.2.15 Alternative arrangements which are proposed as being equivalent to the Rules will receive individual consideration, taking into account any relevant National Authority requirements.
- 1.2.16 Reference should also be made to the relevant Regulations of the *International Convention for the Safety of Life at Sea, 1974* and applicable amendments.
- 1.2.17 Cargo spaces are to be bounded by double bottom and double side tanks or void spaces such that the distance between the cargo tank boundary and the shell plating is not less than that given in *Table 9.1.1 Cargo tank boundary requirements* and *Figure 9.1.1 Cargo tank boundary lines for oil tankers having double bottom and double side tank arrangements* (See *Table 9.1.1 Cargo tank boundary requirements*), except as otherwise specified in Pt 4, Ch 9, 1.2 Application and ship arrangement 1.2.18 and Pt 4, Ch 9, 1.2 Application and ship arrangement 1.2.19. Cargo or fuel oil are not to be carried in double bottom or double side tanks.
- 1.2.18 Where $DWT \geq 5000$ tonnes, double bottom tanks as required by Pt 4, Ch 9, 1.2 Application and ship arrangement 1.2.17 may be dispensed with, provided the following requirements are complied with:
- (a) The cargo height, h_c , in contact with the bottom shell plating is to be not greater than:
- $$h_c = \frac{1,025T_m - 10,2P_v}{1,1\rho}$$
- where the symbols are defined in Pt 4, Ch 9, 1.6 Information required for CSR Double Hull Oil Tankers.
- (b) Where a mid-deck dividing the cargo oil tanks into upper and lower spaces is arranged, it is to be located at a height of not less than the lesser of $\frac{B}{6}$ or 6 m, but not more than $0,6D$, above the base line.
- (c) Below a level $1,5d_b$ above the base line, the cargo tank boundary line may be vertical down to the bottom shell plating as shown in *Figure 9.1.3 Cargo tank boundary lines for oil tankers having mid-deck arrangement* (See Pt 4, Ch 9, 1.2 Application and ship arrangement 1.2.18).
- 1.2.19 Alternative arrangements which are equivalent to Pt 4, Ch 9, 1.2 Application and ship arrangement 1.2.17 will receive individual consideration, taking into account any relevant National Authority requirements.
- 1.2.20 The length of each cargo tank is not to exceed 10 m or the appropriate value obtained from *Table 9.1.4 Permissible length of cargo tanks*, see Pt 4, Ch 9, 1.2 Application and ship arrangement 1.2.20, whichever is the greater.
- 1.2.21 Where $DWT \geq 5000$ tonnes, the cargo pump-room shall be provided with a double bottom such that at any cross-section the depth of each double bottom tank or space shall be such that the distance d_c , as defined in 1.5, is not less than the lesser of $\frac{B}{15}$ m and 2 m
- d_c is in no case to be less than 1 m.
- In the case of cargo pump-rooms whose bottom plate is located above the base line by at least the minimum height required, there will be no need for a double bottom construction in way of the cargo pump-room.
- 1.2.22 Notwithstanding the requirements of Pt 4, Ch 9, 1.2 Application and ship arrangement 1.2.21, above, where the flooding of the cargo pump-room would not render the ballast or cargo pumping system inoperative, a double bottom need not be fitted.

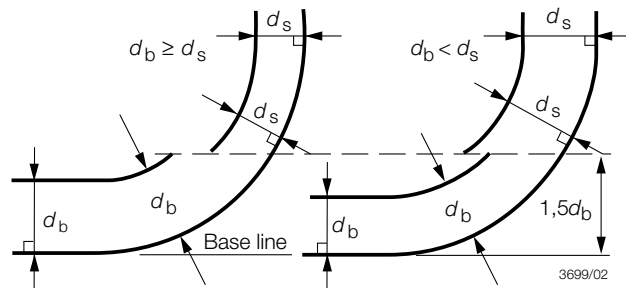

Figure 9.1.1 Cargo tank boundary lines for oil tankers having double bottom and double side tank arrangements (See Table 9.1.1 Cargo tank boundary requirements)

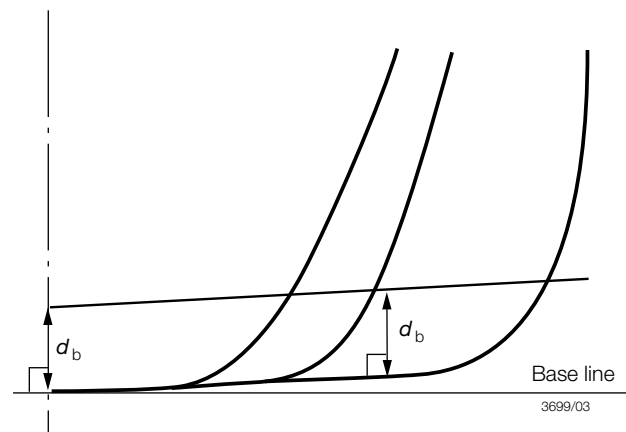

Figure 9.1.2 Cargo tank boundary lines for oil tankers having double bottom arrangement (See Table 9.1.1 Cargo tank boundary requirements)

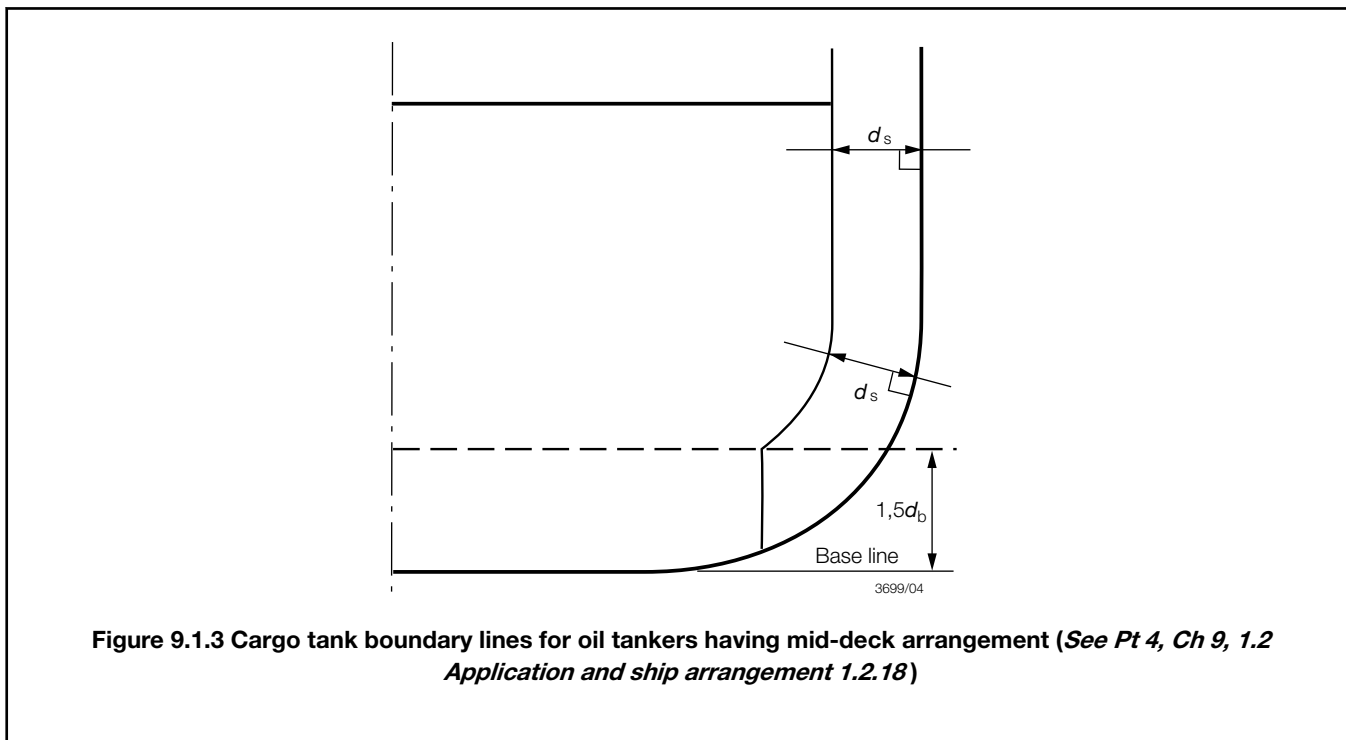

Figure 9.1.3 Cargo tank boundary lines for oil tankers having mid-deck arrangement (See Pt 4, Ch 9, 1.2 Application and ship arrangement 1.2.18)

Table 9.1.4 Permissible length of cargo tanks, see Pt 4, Ch 9, 1.2 Application and ship arrangement 1.2.20

Number of longitudinal bulkheads inside cargo tanks		One (on centreline)	Two	Three (one on centreline)	Where no longitudinal bulkhead is arranged or where longitudinal bulkheads are perforated across breadth of cargo tanks
Length of wing cargo tank		$\left(0,25 \frac{b_i}{B} + 0,15\right) L_L$	$0,2L_L$	$0,2L_L$	$\left(0,5 \frac{b_i}{B} + 0,1\right) L_L$
Length of centre tank	$b_i \geq 0,2B$	—	$0,2L_L$	$0,2L_L$ port and starboard	or
	$b_i \geq 0,2B$	—	$\left(0,5 \frac{b_i}{B} + 0,1\right) L_L$	$\left(0,25 \frac{b_i}{B} + 0,15\right) L_L$ port and starboard	$0,2L_L$ whichever is the lesser

Note The symbols L_L , B and b_i are defined in Pt 4, Ch 9, 1.5 General definitions and symbols.

1.3 Class notation and applicable Rules for CSR Double Hull Oil Tankers

1.3.1 In general, CSR Double Hull Oil Tankers are to comply with Pt 4, Ch 9, 1.3 Class notation and applicable Rules for CSR Double Hull Oil Tankers 1.3.2 to Pt 4, Ch 9, 1.3 Class notation and applicable Rules for CSR Double Hull Oil Tankers 1.3.7 and the IACS Common Structural Rules for Bulk Carriers and Oil Tankers (CSR) for the draught required and will be eligible to be classed **100A1 Double Hull Oil Tanker CSR, ESP**.

1.3.2 Class notations applicable to CSR double hull oil tankers are defined as follows:

- **CSR**

Identifies the double hull oil tanker as being compliant with the IACS Common Structural Rules (CSR)

- **ESP**

Identifies the double hull oil tanker as being subject to an Enhanced Survey Programme as detailed in *Pt 1, Ch 3, 3 Intermediate Surveys - Hull and machinery requirements* and *Pt 1, Ch 3, 7 Special Survey - Oil tankers (including ore/oil ships and ore/bulk/oil ships) - Hull requirements*, see also *Pt 1, Ch 2, 2.3 Class notations (hull) 2.3.12*.

1.3.3 Materials are to comply with the *Rules for the Manufacture, Testing and Certification of Materials* (hereinafter referred to as the Rules for Materials). Corrosion protection is to comply with *Pt 3, Ch 2, 3 Corrosion protection* and *Ch 15 Corrosion Prevention* of the Rules for Materials.

1.3.4 The rudder and rudder stock are to comply with *Pt 3, Ch 13, 2 Rudders*.

1.3.5 Ice strengthening is to be in accordance with *Pt 8 Rules for Ice and Cold Operations*.

1.3.6 The 'Construction Monitoring' (CM) procedures detailed in the *ShipRight Procedures Manual*, published by LR, are mandatory for oil tankers greater than 190 m in length and for other tankers of abnormal hull form, or of unusual structural configuration or complexity.

1.3.7 The 'ShipRight Procedures' for the hull construction of ships are detailed in *Pt 3, Ch 16 ShipRight Procedures for the Design, Construction and Lifetime Care of Ships* and the classification notations and descriptive notes associated with these procedures are given in *Pt 1, Ch 2, 2 Character of classification and class notations*.

1.4 Class notation and applicable Rules for non-CSR Double Hull Oil Tankers

1.4.1 In general, non-CSR Double Hull Oil Tankers are to comply with *Pt 4, Ch 9, 1.4 Class notation and applicable Rules for non-CSR Double Hull Oil Tankers 1.4.2 to Pt 4, Ch 9, 1.4 Class notation and applicable Rules for non-CSR Double Hull Oil Tankers 1.4.7* for the draught required and will be eligible to be classed **100A1 Double Hull Oil Tanker, ESP**.

1.4.2 The notation **ESP** serves to identify the ship as being subject to an Enhanced Survey Programme as detailed in *Pt 1, Ch 3, 3 Intermediate Surveys - Hull and machinery requirements* and *Pt 1, Ch 3, 7 Special Survey - Oil tankers (including ore/oil ships and ore/bulk/oil ships) - Hull requirements*, see also *Pt 1, Ch 2, 2.3 Class notations (hull) 2.3.12*.

1.4.3 At the Owner's request, the notation **MARPOL 20.1.3** may be appended to the notation **100A1 Double Hull Oil Tanker** for vessels not meeting the minimum double side width (d_s) requirements of *Table 9.1.1 Cargo tank boundary requirements* but which comply with MARPOL Annex I, Regulation 20.1.3.

1.4.4 At the Owners request, the notation **MARPOL 21.1.2** may be appended to the notation **100A1 Double Hull Oil Tanker** for vessels of less than 5000 tonnes deadweight which have a double hull in accordance with MARPOL Annex I, Regulation 21.1.2.

1.4.5 Where the length of the ship is greater than 190 m, or where the structural arrangements are considered such as to necessitate it, the scantlings of the primary supporting structure are to be assessed by direct calculation and the ShipRight notations **SDA, FDA** and **CM** are mandatory, see *Pt 4, Ch 9, 1.4 Class notation and applicable Rules for non-CSR Double Hull Oil Tankers 1.4.5* and *Pt 4, Ch 9, 14 Direct calculations*.

1.4.6 The 'ShipRight Procedures' for the hull construction of ships are detailed in *Pt 3, Ch 16 ShipRight Procedures for the Design, Construction and Lifetime Care of Ships* and the classification notations and descriptive notes associated with these procedures are given in *Pt 1, Ch 2, 2 Character of classification and class notations*.

1.4.7 The disposition of transverse bulkheads is to comply with the requirements of *Pt 3, Ch 3, 4 Bulkhead requirements*, as applicable to ships with machinery located aft.

1.4.8 Arrangements and scantlings forward and aft of the cargo tank region are to comply with *Pt 3, Ch 5 Fore End Structure, Pt 3, Ch 6 Aft End Structure* and *Pt 3, Ch 7 Machinery Spaces*. The remaining requirements of Part 3 are also to be complied with as appropriate to the intended arrangements.

1.4.9 Arrangements pertaining to gangways, bulwarks and rails are to comply with the requirements of *Pt 3, Ch 8 Superstructures, Deckhouses and Bulwarks*.

1.4.10 The structural configurations may include one or more of the arrangements shown in *Table 9.1.3 Structural arrangement*. These provisions do not preclude the fitting of additional bulkheads or the perforation of longitudinal bulkheads.

1.4.11 The bottom shell, inner bottom and deck are generally to be framed longitudinally in the cargo tank region where the ship length, L , exceeds 75 m. However, consideration will be given to alternative proposals for ships of special design.

1.4.12 The side shell, inner hull bulkheads and longitudinal bulkheads are generally to be longitudinally framed where the ship length, L , exceeds 150 m, but alternative proposals, taking account of resistance to buckling, will be considered.

- 1.4.13 Where the side shell is longitudinally framed, the inner hull bulkheads are to be similarly constructed.
- 1.4.14 Provided the ship length, L , does not exceed 200 m the longitudinal bulkheads may be horizontally corrugated. Vertically corrugated centreline bulkheads may also be considered on the basis of direct calculations.
- 1.4.15 In general, the primary member scantlings will require to be determined by direct calculation, see also *Table 9.1.3 Structural arrangement*.
- 1.4.16 Alternative arrangements, which are proposed as being equivalent to the Rules, will receive individual consideration. Particular attention is to be paid to deflection of members and to the ability of the structure to resist buckling. Where necessary, additional calculations will be required.
- 1.4.17 For additional requirements for single hull oil tankers, see *Pt 4, Ch 10 Single Hull Oil Tankers*.
- 1.4.18 The scantlings of structural items may be determined by direct calculation.

1.5 General definitions and symbols

1.5.1 The following symbols and definitions are applicable to this chapter unless otherwise stated:

L, L_L, B, D, T as defined in *Pt 3, Ch 1, 6 Definitions*.

d_c = the height between the ship's base line and the bottom of the cargo pump-room, in metres

DWT = deadweight, in tonnes, at the summer load waterline

b = the width of plating supported by the primary or secondary member, in metres or mm respectively

b_e = the effective width, in metres, of end brackets as determined from *Pt 3, Ch 3, 3 Structural idealisation*

b_l = minimum distance from side shell to inner hull/outer longitudinal bulkhead of the tank in question measured inboard at right angles to the centreline at the summer load waterline, in metres, see *Table 9.1.4 Permissible length of cargo tanks, see Pt 4, Ch 9, 1.5 General definitions and symbols*

d_b = the distance, in metres, between the bottom of the cargo tanks and the moulded line of the bottom shell plating measured at right angles to the bottom shell plating as shown in *Table 9.1.1 Cargo tank boundary requirements* and *Table 9.1.2 Oil cargoes suitable for carriage in oil tankers, see Note 1*

d_s = the distance, in metres, between the cargo tank boundary and the moulded line of the side shell plating measured at any cross-section at right angles to the side shell as shown in *Figure 9.1.1 Cargo tank boundary lines for oil tankers having double bottom and double side tank arrangements (See Table 9.1.1 Cargo tank boundary requirements)* and *Figure 9.1.3 Cargo tank boundary lines for oil tankers having mid-deck arrangement (See Pt 4, Ch 9, 1.5 General definitions and symbols)*

h = the load height applied to the item under consideration, in metres

k_L, k = higher tensile steel factors. For the determination of these factors, see *Pt 3, Ch 2, 1 Materials of construction*. For mild steel, k_L, k may be taken as 1,0

l_e = effective length, in metres, of the primary or secondary member, measured between effective span points. For determination of span points, see *Pt 3, Ch 3, 3 Structural idealisation*

s = spacing of secondary members, in mm

t = thickness of plating, in mm

I = the moment of inertia, in cm^4 , of a primary or secondary member, in association with an effective width of attached plating determined in accordance with *Pt 3, Ch 3, 3 Structural idealisation*

L_1 = length of ship, in metres, but need not be taken greater than 190 m

P_v = pressure/vacuum relief valve positive setting, in bar

T_m = minimum operating moulded draught of the ship at amidships under any expected cargo loading condition, in metres

Z = the section modulus, in cm^3 , of the primary or secondary member, in association with an effective width of attached plating determined in accordance with Pt 3, Ch 3, 3 Structural idealisation

ρ = maximum cargo density, in t/m^3 .

1.5.2 Where symbols not defined in Pt 4, Ch 9, 1.5 General definitions and symbols 1.5.1 are used these are defined at the head of the Section concerned.

1.5.3 For oil tankers of double hull configuration the main structural and spatial terminology within the cargo length, as used in this Chapter, is shown in Figure 9.1.4 Structural and spatial terminology.

1.5.4 The expression 'primary member' as used in this Chapter is defined as a girder, floor, transverse, vertical web, stringer, cross-tie or buttress. 'Secondary members' are supporting members other than primary members.

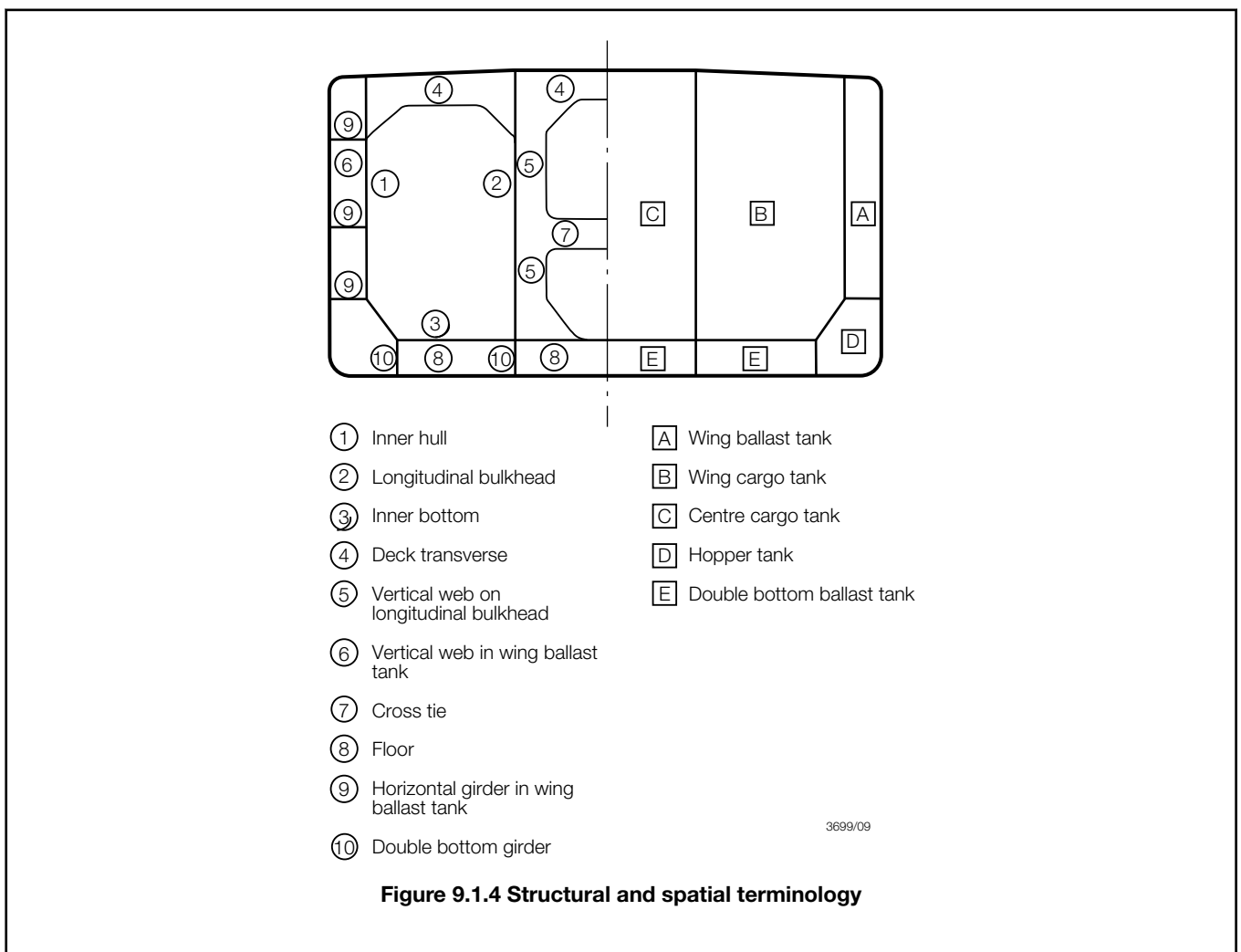

1.6 Information required for CSR Double Hull Oil Tankers

1.6.1 In addition to the plans required by IACS Common Structural Rules (CSR) the following additional plans and information is to be submitted:

- Rudder, stock and tiller;
- Ice Strengthening.
- Freeboard plan or equivalent showing freeboards and items relative to the conditions of assignment.

1.7 Information required for Non-CSR Double Hull Oil Tankers

1.7.1 In addition to the plans required by *Pt 3, Ch 1, 5 Information required*, plans showing the connections for all longitudinals and other framing members and arrangements at intersections of transverse and longitudinal framing are also to be submitted.

1.7.2 Any dry tanks, or tanks for water ballast only, are to be indicated on the principal structural and arrangement plans.

1.7.3 The information required by *Pt 3, Ch 4, 4 Information required* is to be forwarded as soon as possible and preferably when the midship section is submitted.

1.7.4 A docking plan is to be submitted for consideration of strength requirements in association with the intended docking condition.

1.7.5 A plan showing the location of all openings in the deck is to be submitted. Where it is intended to provide holes in the deck for staging wires, these holes are also to be shown. Full particulars of the proposed closing arrangements for all deck openings are to be submitted.

1.7.6 Information is required indicating the equipment provided for the acceptable means of access to meet the minimum requirements for Close-up Surveys, see also *Pt 4, Ch 9, 13.2 Access to spaces in the cargo area 13.2.8, Pt 4, Ch 9, 13.2 Access to spaces in the cargo area 13.2.9* and *Pt 1, Ch 3, 7 Special Survey - Oil tankers (including ore/oil ships and ore/bulk/oil ships) - Hull requirements*.

1.7.7 A diagrammatic plan verifying compliance with the requirements of *Pt 4, Ch 9, 1.2 Application and ship arrangement 1.2.17* or *Pt 4, Ch 9, 1.2 Application and ship arrangement 1.2.18* as appropriate is to be submitted.

■ *Section 2* **Materials and protection**

2.1 General

2.1.1 Materials, grades of steel and protection of materials are to comply with the requirements of *Pt 3, Ch 2 Materials* and the *Rules for the Manufacture, Testing and Certification of Materials, July 2015*.

2.2 Corrosion protection coatings for salt-water ballast spaces

2.2.1 The requirements of *Pt 3, Ch 2, 3.6 Application of coatings and alternative means of protection* and *Ch 15 Corrosion Prevention* of the Rules for Materials are to be complied with.

2.3 Aluminium structure, fittings and paint

2.3.1 Aluminium may, under certain circumstances give rise to incendive sparking on impact with steel, the following requirements are therefore to be complied with:

- (a) Aluminium fittings in tanks used for the carriage of oil and in cofferdams and pump-rooms are to be avoided wherever possible.
- (b) Where fitted, aluminium fittings, units and supports, in tanks used for the carriage of oil, cofferdams and pump-rooms are to satisfy the requirements specified in *Pt 3, Ch 2, 3 Corrosion protection* for aluminium anodes.
- (c) The danger of mistaking aluminium anodes for zinc anodes must be emphasised. This gives rise to increased hazard if aluminium anodes are inadvertently fitted in unsuitable locations.
- (d) The underside of heavy portable aluminium structures such as gangways, etc. is to be protected by means of hard plastic or wood cover in order to avoid the creation of smears when dragged or rubbed across steel, which if subsequently struck, may create an incendive spark. It is recommended that such protection be permanently and securely attached to the structures.

2.3.2 For permissible locations of aluminium anodes, see *Pt 3, Ch 2, 3.4 Aluminium and magnesium anodes*.

2.3.3 Paint containing aluminium should not be used in positions where cargo vapours may accumulate unless it has been shown by appropriate tests that the paint to be used does not increase the incendive sparking hazard. Tests need not be performed for coatings containing less than 10 per cent aluminium by weight.

2.4 Other materials

2.4.1 The suitability of coatings and their compatibility with intended cargoes are the responsibility of the Builder and the Owner. LR will, however, require the confirmation of the coating manufacturers that coatings which are used to protect the cargo tank structure are in order for the list of defined cargoes. A copy of the coating manufacturer's product resistance list is to be placed on board.

2.4.2 Attention is drawn to the requirements of *Pt 3, Ch 11, 7.1 Materials 7.1.4* in respect of compatibility of cargoes and hatch packing materials. The packing material is to be resistant to both the liquids and vapours to which it is exposed.

2.4.3 Some plastics and rubbers are unsuitable for certain cargoes other than oil. In such cases the manufacturer's advice should be sought.

2.4.4 Some materials or their alloys are unsuitable for certain cargoes other than oil. Where such cargoes are to be carried, the use of these materials is not permitted in locations where they may come into contact with the cargo or its vapours, see also *Pt 4, Ch 9, 1.1 General 1.1.7*.

■ Section 3 Longitudinal strength

3.1 General

3.1.1 The longitudinal strength standard is to comply with the relevant requirements of *Pt 3, Ch 4 Longitudinal Strength*.

3.1.2 The readout points for loading instruments, fitted in accordance with the requirements of *Pt 3, Ch 4, 8.3 Loading instrument*, are to be positioned at the transverse bulkheads. In general, except when the instrument calculates the maximum values between readout points, the spacing of readout points within the cargo tank length is not to exceed five per cent of the ship length with intermediate points arranged between bulkheads as necessary.

3.2 Symbols

3.2.1 The symbols used in this Section are defined in *Pt 4, Ch 9, 1.5 General definitions and symbols*.

3.3 Loading conditions

3.3.1 The loading conditions which are to be included in the Loading Manual and examined for longitudinal strength are given in *Pt 3, Ch 4, 5 Hull bending strength*.

3.3.2 The Loading Manual is to contain the calculated still water bending moments and shear forces for the conditions proposed and the maximum permissible values calculated in accordance with *Pt 3, Ch 4 Longitudinal Strength*.

3.3.3 The strengthening of bottom forward derived in accordance with the requirements of *Pt 3, Ch 5, 1 General* is to be based on the minimum draught forward obtained using segregated ballast tanks only, without recourse to ballasting of cargo tanks.

3.3.4 Where bottom forward strengthening has not been arranged, at least one ballast departure and one ballast arrival condition providing for a forward draught of at least $0,045L$ is to be included in the Loading Manual, see also *Pt 3, Ch 5, 1.5 Strengthening of bottom forward*.

3.3.5 Where part-load conditions are proposed with a forward draught less than that for which the bottom forward arrangements and scantlings have been approved, the Loading Manual is to provide for the addition of ballast in segregated ballast tanks only as necessary to attain the required draught in heavy weather.

3.3.6 Conditions which provide for wing and centre cargo tanks abreast to be filled, with adjacent wing and centre cargo tanks empty, should, in general, be avoided. Similarly, conditions which provide for differential loading of port and starboard wing cargo tanks with centre cargo tanks empty should also be avoided. Where such conditions are contemplated, they will be subject to special consideration which may involve additional calculation in respect of the resultant effects on transverse strength and centre tank cross-tie.

3.3.7 Where a double bottom tank is omitted in accordance with *Pt 4, Ch 9, 1.3 Class notation and applicable Rules for CSR Double Hull Oil Tankers 1.3.7* a minimum operating draught T_m is to be indicated on the midship section plan, the Loading Manual and Loading Instrument.

3.3.8 Tanks intended for water ballast are to be indicated in the Loading Manual.

3.3.9 Where loading conditions having partially filled tanks are contemplated, attention is drawn to the need to ensure that the scantlings of the boundary bulkheads are capable of withstanding the loads imposed by the movement of liquid in the tanks, see *Pt 4, Ch 9, 6.1 General 6.1.2, Pt 4, Ch 9, 7.1 General 7.1.2 and Pt 4, Ch 9, 14.2 Procedures 14.2.2.*

■ **Section 4**
Hull envelope plating

4.1 General

4.1.1 The thickness of hull envelope plating amidships is to be as necessary to comply with the hull section modulus, shear strength and buckling requirements of *Pt 3, Ch 4 Longitudinal Strength*, but is to be not less than as shown in *Table 9.4.1 Hull envelope plating - minimum thickness, in mm* for the parts itemised in *Figure 9.4.1 Hull envelope plating - Itemisation of parts* (See *Table 9.4.1 Hull envelope plating - minimum thickness, in mm*). Panel stability is also to be confirmed by direct calculation taking account of shear stress and direct stresses derived from both transverse and longitudinal strength investigation.

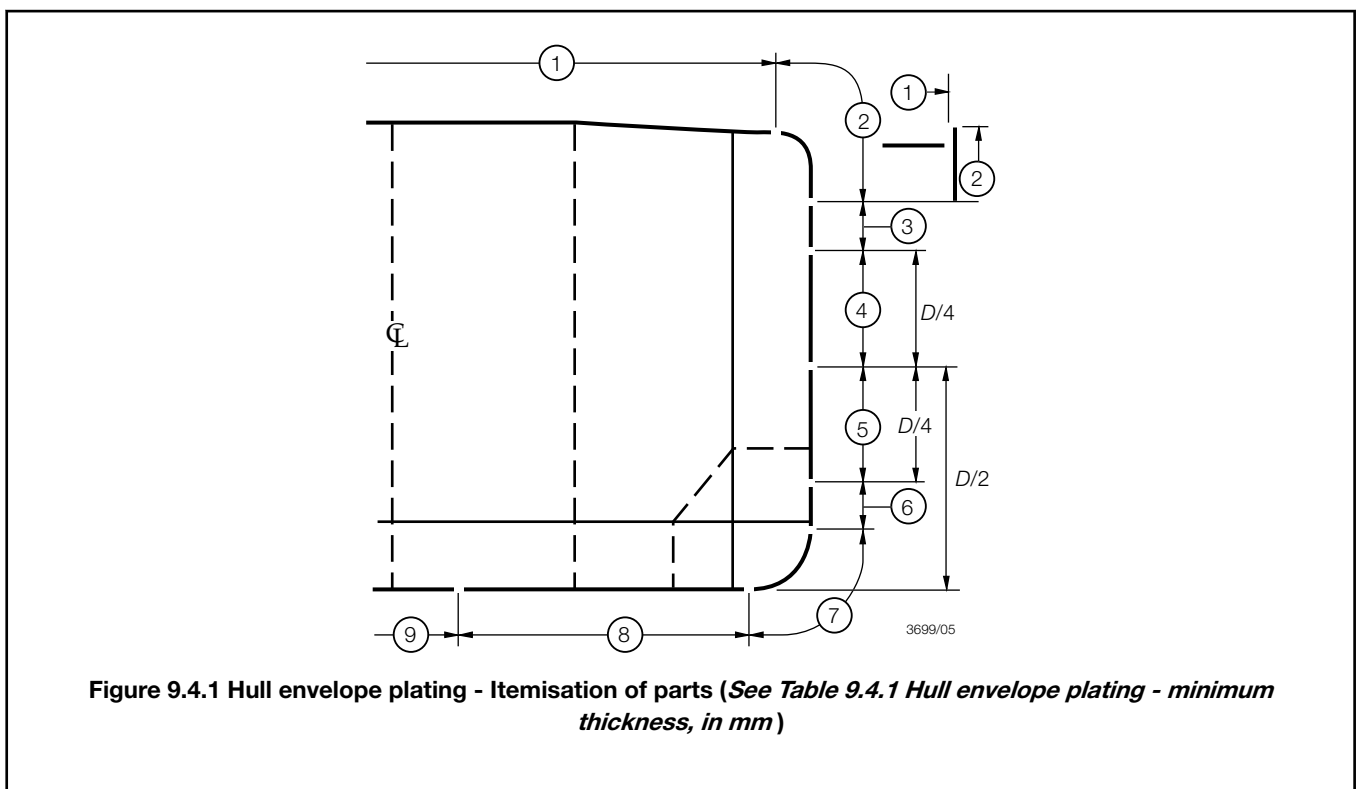

Figure 9.4.1 Hull envelope plating - Itemisation of parts (See Table 9.4.1 Hull envelope plating - minimum thickness, in mm)

4.1.2 For requirements in respect of structural details, bilge keels, attachments, etc. see *Pt 3, Ch 10 Welding and Structural Details*. In addition the *ShipRight FDA Procedure, Structural Detail Design Guide* (SDDG), indicates recommended structural design configurations for double hull tanker structural details to assess and improve the relative fatigue life performance of the details in critical areas.

4.2 Symbols

4.2.1 The symbols used in this Section are defined as follows:

$$F_D, F_B = \text{as defined in } Pt\ 3, Ch\ 4, 5.7\ \text{Local reduction factors}$$

$$F_M = \text{the greater of } F_D \text{ or } F_B$$

$$J = 1720,5 \sqrt{\frac{1 - \frac{1}{\alpha}}{\sigma_o}} \text{ for } \alpha \leq 2$$

$$\left(J = 549,3 \sqrt{\frac{1 - \frac{1}{\alpha}}{\sigma_o}} \text{ for } \alpha \leq 2 \right)$$

$$J = 860,7 \sqrt{\frac{\alpha}{\sigma_o}} \text{ for } \alpha > 2$$

$$\left(J = 274,8 \sqrt{\frac{\alpha}{\sigma_o}} \text{ for } \alpha > 2 \right)$$

s = spacing, in mm, of longitudinals or transverse frames. Except where indicated in the text, s is not to be taken less than:

$$470 + \frac{L}{0,6} \text{ mm}$$

or 700 mm whichever is the lesser. For limitations in end regions, see Pt 3, Ch 5, 3 Shell envelope plating and Pt 4, Ch 6, 3 Longitudinal strength

C_w = a wave head, in metres

$$= 7,71 \times 10^{-2} L e^{-0,0044L}$$

where

e = base of natural logarithms 2,7183

R_B = bilge radius, in mm, as defined in Table 1.5.2 Bottom shell and bilge plating in Pt 4, Ch 1 General Cargo Ships

S = overall span of frame, in mm, measured between deck and bottom support points or to, or between, stringers, where fitted

T₁ = *T* but to be taken not less than 0,05*L* m

$$\alpha = \frac{\sigma_o}{\sigma_c}$$

σ_c = maximum compressive hull vertical bending stress, in N/mm² (kgf/mm²) given by σ_D and σ_B as defined in Pt 3, Ch 4, 5.6 Permissible hull vertical bending stresses 5.6.1 as appropriate

= For ships of normal design, not exceeding 90 metres in length, the value of maximum compressive hull vertical bending stress may be determined as follows:

= at strength deck

$$= \sigma_D = 654LB \frac{Z_{\min}}{Z_D} \sigma \times 10^{-6} \text{ N/mm}^2 \text{ (kgf/mm}^2\text{)}$$

= at keel

$$= \sigma_B = 654LB \frac{Z_{\min}}{Z_B} \sigma \times 10^{-6} \text{ N/mm}^2 \text{ (kgf/mm}^2\text{)}$$

= where *Z_{min}*, *Z_D*, *Z_B* and *σ* are in accordance with Pt 3, Ch 4, 5 Hull bending strength

σ_o = specified minimum yield stress, in N/mm² (kgf/mm²)

h_{T1} = *T* + *C_w* m but need not be taken greater than 1,36*T*

h_{T2} = *T* + 0,5*C_w* m but need not be taken greater than 1,2*T*

= For longitudinally framed bottom and bilge plating *T* is to be taken as *T₁*

Other symbols are defined in Pt 4, Ch 9, 1.5 General definitions and symbols.

Table 9.4.1 Hull envelope plating - minimum thickness, in mm

Longitudinally framed	Item	Item No. see Fig. 9.4.1	Transversely framed, see Pt 4, Ch 9, 1.3 Class notation and applicable Rules for CSR Double Hull Oil Tankers for limits of application
$t = \frac{s}{j} + 2,0$ see Note 1	Deck	1	see Pt 4, Ch 9, 1.3 Class notation and applicable Rules for CSR Double Hull Oil Tankers
$t = \frac{s}{j} + 2,0$ or $t = 0,0042s\sqrt{h_{T1}k}$ whichever is the greater see Note 1	Sheerstrake and gunwale	2	$t = \frac{0,00085s}{1 + (\frac{s}{S})^2} (0,083L_1 + 10) \sqrt{\frac{F_D}{k_L}}$ see Note 6 or $t = 0,0042s\sqrt{h_{T1}k}$ whichever is the greater see Note 1
$t = 0,001s (0,059L_1 + \gamma) \sqrt{\frac{F_D}{k_L}}$ see Notes 6 and 7 or $t = 0,0042s\sqrt{h_{T1}k}$ whichever is the greater see Note 1	Side shell above mid- depth	3	$t = \frac{0,00085s}{1 + (\frac{s}{S})^2} (0,083L_1 + 10) \sqrt{\frac{F_D}{k_L}}$ see Notes 6 & 7 or $t = 0,0042s\sqrt{h_{T1}k}$ whichever is the greater see Note 1
		4	$t = 0,001s (0,059L_1 + \gamma) \sqrt{\frac{F_M}{k_L}}$ see Notes 6 and 7 or $t = 0,0051s\sqrt{h_{T1}k}$ whichever is the greater see Note 1
$t = 0,001s (0,059L_1 + \gamma) \sqrt{\frac{F_B}{k_L}}$ see Notes 6 and 7 But not less than: (a) $t = 0,0042s\sqrt{h_{T1}k}$ at mid-depth Intermediate thickness by interpolation (b) $t = 0,0054s\sqrt{\frac{h_{T2}k}{2 - F_B}}$ Intermediate thickness by interpolation at upper turn of bilge See Notes 1 and 2	Side shell below mid- depth	5	$t = \frac{0,00085s}{1 + (\frac{s}{S})^2} (0,083L_1 + 10) \sqrt{\frac{F_B}{k_L}}$ see Notes 2, 6 and 7 or $t = 0,0056s\sqrt{\frac{h_{T2}k}{1,8 - F_B}}$ whichever is the greater see Note 1
		6	$t = \frac{0,00085s}{1 + (\frac{s}{S})^2} (0,083L_1 + 10) \sqrt{\frac{F_B}{k_L}}$ see Notes 2, 6 and 7 or $t = 0,0056s\sqrt{\frac{h_{T2}k}{1,8 - F_B}}$ whichever is the greater see Note 1
$t = \frac{s}{j} + 2,0$ or $t = 0,0052s\sqrt{\frac{h_{T2}k}{1,8 - F_B}}$ mm whichever is the greater see Note 1	Bilge (see Note 4)	7	$t = \frac{0,00085s}{1 + (\frac{s}{S})^2} (0,083L_1 + 10) \sqrt{\frac{F_B}{k_L}}$ see Notes 6 and 7 or $t = 0,0063s\sqrt{\frac{h_{T2}k}{1,8 - F_B}}$ mm whichever is the greater see Note 1
	Bottom shell	8	see Pt 4, Ch 9, 1.3 Class notation and applicable Rules for CSR Double Hull Oil Tankers
As for item 8, +2mm, but need not exceed $25\sqrt{k}$ mm	Keel	9	see Pt 4, Ch 9, 1.3 Class notation and applicable Rules for CSR Double Hull Oil Tankers

Note 1. The thickness is also to satisfy the buckling requirements of Pt 3, Ch 4, 7 Hull buckling strength.

Note 2. The thickness of side shell plating need not exceed that which would be required for the bottom shell using the spacing of the side shell longitudinals.

Note 3. In no case is the plating thickness to be less than the cargo tank minimum value given in *Pt 4, Ch 9, 10 Construction details and minimum thickness*, or the basic shell end thickness for taper given in *Pt 3, Ch 5 Fore End Structure* and *Pt 3, Ch 6 Aft End Structure*.

Note 4. See also *Pt 4, Ch 9, 4.6 Bilge plating 4.6.2* concerning plating thickness where longitudinal framing is fitted at bottom and side, but omitted in way of bilge.

Note 5. Keel thickness is in no case to be less than that of the adjacent bottom shell plating.

Note 6. Where separate maximum sagging and hogging still water bending moments are assigned, F_D may be based on the sagging moment and F_B on the hogging moment.

Note 7. Outside the Rule minimum region of higher tensile steel as defined in *Pt 3, Ch 3, 2.6 Vertical extent of higher tensile steel 2.6.1* the value of k_L may be taken as 1,0.

4.3 Deck plating

4.3.1 The midship thickness of deck plating is to be maintained for 0,4L amidships and tapered outside this region in association with the deck longitudinals in accordance with *Pt 4, Ch 9, 5.5 Deck longitudinals outside 0,4L amidships*. The midship thickness may, however, be required over an increased extent if it is shown to be necessary by the bending moment curves. Where partial filling of the tanks is contemplated the deck plating is also to comply with the requirements of *Pt 4, Ch 9, 6.1 General 6.1.2*.

4.3.2 For ships not exceeding 200 m in length, the deck thickness outside 0,4L amidships is to be not less than $\frac{s}{80}$ at any point within the cargo tank region. For lengths of 250 m and over, the thickness is to be not less than $\frac{s}{70}$. Intermediate values are to be obtained by interpolation. For the purpose of this paragraph, the minimum value of s given in *Pt 4, Ch 9, 4.2 Symbols 4.2.1* is not to be applied.

4.3.3 The plating thickness outside 0,4L amidships is to be not less than:

$$t = \frac{s}{J} + 2,0 \text{ mm}$$

where

J = is defined in *Pt 4, Ch 9, 4.2 Symbols 4.2.1* using σ_o of the plating at the location under consideration.

4.4 Sheerstrake

4.4.1 The midship sheerstrake thickness is to be maintained for 0,4L amidships and tapered outside this region as provided for in *Pt 3, Ch 5 Fore End Structure* and *Pt 3, Ch 6 Aft End Structure*. In the taper region, however, the sheerstrake thickness need not exceed the adjacent deck or shell thickness, whichever is the greater.

4.4.2 The width of sheerstrake for 0,4L amidships is to be not less than that required by *Table 2.2.1 Material classes and grades*.

4.4.3 Where a rounded sheerstrake is incorporated, the radius is not, in general, to be less than 15 times the thickness. The radius is to be made by careful cold rolling or bending.

4.5 Shell plating

4.5.1 The midship thicknesses of side and bottom shell plating are to be maintained for 0,4L amidships and tapered outside this region as provided for in *Pt 3, Ch 5 Fore End Structure* and *Pt 3, Ch 6 Aft End Structure*. The midship thicknesses may be required over an increased extent if it is shown to be necessary by the bending moment or shear force curves.

4.5.2 The requirements of *Pt 3, Ch 5 Fore End Structure* are to be complied with in respect of the thickness of bottom shell forward.

4.6 Bilge plating

4.6.1 The midship thickness of the bilge plating is to be maintained for $0,4L$ amidships and tapered outside this region as provided for in *Pt 3, Ch 5 Fore End Structure* and *Pt 3, Ch 6 Aft End Structure*.

4.6.2 Where longitudinal bottom and side framing is adopted, but longitudinals are omitted between the upper and lower extremities of the bilge radius, the bilge thickness is to be not less than $\frac{R_B F_B}{165k_L}$ in addition to the required minimum thickness derived from *Table 9.4.1 Hull envelope plating - minimum thickness, in mm*. The spacing of transverse supports associated with such an arrangement is to comply with the requirements of *Pt 4, Ch 9, 5.4 Bilge longitudinals and brackets*.

4.6.3 Where bilge longitudinals are omitted, the plating thickness outside $0,4L$ amidships will be considered in relation to the support derived from the hull form and internal stiffening arrangements. Due regard will be taken of the possibility of increased loading in the forward region.

4.7 Keel

4.7.1 The midship keel thickness is to be maintained throughout the cargo tank region, except as required by *Table 9.4.1 Hull envelope plating - minimum thickness, in mm*, Note 5.

4.7.2 The width of the keel over the cargo tank region is to be not less than:

$70B$ mm but need not exceed 1800 mm and is to be not less than 750 mm.

4.8 Taper of higher tensile steel

4.8.1 Where higher tensile steel is used amidships and mild steel at the ends, the thickness of bottom shell, bilge and sheerstrake is to be tapered as provided for in *Pt 3, Ch 3 Structural Design*, *Pt 3, Ch 5 Fore End Structure* and *Pt 3, Ch 6 Aft End Structure*.

4.8.2 Higher tensile steel deck plating is to be tapered in association with attached longitudinals as provided for in *Pt 4, Ch 9, 5.5 Deck longitudinals outside $0,4L$ amidships*.

4.9 Thicknesses at ends of erections

4.9.1 The deck plating thickness at the poop front is to extend into the poop for a distance at least equal to one-third of the breadth, B .

4.9.2 If the poop front extends to within $0,25L$ of amidships, the sheerstrake and the stringer plate at the break are to be increased by 20 per cent. No increase is required if the poop front is $0,3L$ from amidships or greater. The increase at intermediate lengths is to be obtained by interpolation and is to be applied to the tapered thickness of the sheerstrake and stringer plate.

4.9.3 Where the poop extends to within $0,3L$ of amidships and the enclosed machinery opening extends to within $\frac{B}{3}$ of the poop front and has a width exceeding one half of the breadth of the ship at the poop front, the thickness of deck plating may require to be increased. The forward corners of the casing opening are to be well rounded.

4.10 Deck openings

4.10.1 Openings in the deck are to be kept to the minimum number consistent with operational requirements.

4.10.2 Plate panels in which openings are cut are to be adequately stiffened, where necessary, against compression and shear buckling.

4.10.3 The corners of all openings are to be well rounded, and the edges smooth.

4.10.4 Where the stress concentration factor in way of the opening exceeds 2,4, edge reinforcement is generally to be fitted. This is normally to be in the form of a spigot of adequate dimensions, but alternative arrangements will be considered.

4.10.5 Alternatively, the shape of the opening is to be such that a stress concentration factor of 2,4 is not exceeded.

4.10.6 In this respect, reinforcement will not, in general, be required in way of:

- (a) elliptical openings having their major axis fore and aft and ratios of length to breadth not less than 2 to 1, or
- (b) openings of other shapes, provided it has been shown by suitable tests that the stress concentration factor does not exceed 2,4.

4.10.7 Circular openings of diameter up to 325 mm will also be accepted, provided that they are situated at such a distance from any other opening that there is an intervening width of plating of not less than five times the diameter of the smaller of the two openings.

4.10.8 Where within 0,4L amidships deck openings have a total breadth or shadow area breadth in one transverse section that exceeds the limitation given in *Pt 3, Ch 3, 3.4 Calculation of hull section modulus 3.4.4* and *Pt 3, Ch 3, 3.4 Calculation of hull section modulus 3.4.5*, compensation will be required to restore the excess. This is generally to be arranged by increasing the deck plate thickness, but other proposals will be considered.

4.10.9 Where a deck longitudinal is cut in way of an opening, within 0,4L amidships, compensation is to be arranged to ensure full continuity of area.

4.10.10 The area of any edge reinforcement which may be required is not to be taken into account in determining the required sectional area of compensation unless such reinforcement is designed to absorb the loadings from cut longitudinals in way of opening.

4.10.11 Increased scantlings and/or compensation may also be required for large openings outside 0,5L amidships, or where openings are close to breaks of superstructure or other areas of high stress in any location on the ship.

4.10.12 Where small diameter threaded openings for staging wires are arranged on the upper deck, they are to be located clear of the other openings and similar areas of stress concentration. Care is to be taken to ensure a gradual transition at the thread ends and the edges of the holes are to be smooth. The closing arrangements are to be as required by *Pt 4, Ch 9, 13 Access arrangements and closing appliances*.

4.11 Shell openings

4.11.1 Sea inlets in pump-rooms situated within 0,4L amidships, are, if practicable, to be fitted clear of the bilge radius. All openings are to be arranged so as to minimise discontinuity of transverse frames, longitudinals or bilge keels. Compensation is to be provided for all openings within 0,4L amidships and may also be required for openings in the vicinity of the poop front. The compensation should, if possible, take the form of an insert plate rather than a doubler.

4.11.2 If openings are not circular or oval, the corners are to be rounded with as large a radius as practicable.

4.12 Superstructures

4.12.1 The thickness of plating forming the deck and sides of forecastles and poops is to be as required by *Pt 3, Ch 5 Fore End Structure, Pt 3, Ch 6 Aft End Structure* and *Pt 3, Ch 8 Superstructures, Deckhouses and Bulwarks*.

■ *Section 5* **Hull framing**

5.1 General

5.1.1 In the cargo tank region, the scantlings of deck, bottom and side longitudinals, and of transverse side framing, where fitted, are to be in accordance with the requirements of this Section.

5.1.2 Longitudinal and transverse framing members outside the cargo tank region are to comply with the requirements of *Pt 3, Ch 5, 4 Shell envelope framing, Pt 3, Ch 6, 4 Shell envelope framing* and *Pt 3, Ch 7 Machinery Spaces*, as appropriate to their location.

5.1.3 Outside the cargo tank region the structure is to be scarfed into the end structure as provided for in *Pt 3, Ch 5 Fore End Structure, Pt 3, Ch 6 Aft End Structure* and *Pt 3, Ch 7 Machinery Spaces*.

5.2 Symbols

5.2.1 The symbols used in this Section are defined as follows:

b_f = the width of the face plate, in mm, of the side longitudinal under consideration, see *Figure 9.5.1*
Definition of b_f and b_{f1}

b_{f1} = the minimum distance, in mm, from the edge of the face plate of the side longitudinal under consideration to the centre of the web plate, see *Figure 9.5.1 Definition of b_f and b_{f1}*

b_1 = the value as defined in *Table 9.5.3 Determination of b_1*

$$c_1 = \frac{60}{225 - 165F_D} \text{ at deck}$$

$$= 1,0 \text{ at } \frac{D}{2}$$

$$= \frac{75}{225 - 150F_B} \text{ at base line of ship}$$

intermediate values of c_1 by interpolation

$$c_2 = \frac{165}{345 - 180F_D} \text{ at deck}$$

$$= 1,0 \text{ at } \frac{D}{2}$$

$$= \frac{165}{345 - 180F_B} \text{ at base line of ship}$$

intermediate values of c_2 by interpolation

d_w = depth of web, in mm

h = distance of longitudinal below deck at side, in metres. For deck longitudinals, $h = 0$

h_o = the distance, in metres, from the mid-point of span of the stiffener to the highest point of tank, excluding hatchway

$h_1 = \left(h_o + \frac{D_1}{8} \right)$, but in no case to be taken less than $\frac{L_1}{56}$ m or $(0,01L_1 + 0,7)$ m, whichever is the greater, and need not be taken greater than $\left(0,75D + \frac{D_1}{8} \right)$ for bottom longitudinals

h_2 = distance, in metres, from mid-point of span of transverse side frame to deck at side measured at mid-length of tank, but to be taken not less than 2,5 m

$h_3 = h_o + Rb_1$, but need not be taken greater than $(0,75D + Rb_1)$ for bottom longitudinals

l_e = effective length, in metres, of longitudinals measured between span points, but to be taken not less than 1,5 m in double bottom and 2,5 m elsewhere. For determination of span points, see *Pt 3, Ch 3, 3 Structural idealisation*.

t_f = thickness of flange, in mm

t_s = thickness of the bilge shell plating, in mm

t_w = thickness of web, in mm

$D1 = D$, in metres, but is to be taken not less than 10 and need not be taken greater than 16

$F_B =$ as defined in *Pt 3, Ch 4, 5.7 Local reduction factors*

F_D = as defined in Pt 3, Ch 4, 5.7 Local reduction factors

F_1 = a factor determined from Table 9.5.1 Values of F1

F_2 = a factor determined from Table 9.5.2 Values of F2

$R = \sin\theta$

= where θ is the roll angle, in degrees

$$= \text{and } \sin \theta = \left(0,45 + 0,1\frac{L}{B}\right)\left(0,54 - \frac{L}{1270}\right)$$

R_B = bilge radius, in mm, as defined in Table 1.5.2 Bottom shell and bilge plating in Pt 4, Ch 1 General Cargo Ships

Other symbols are defined in Pt 4, Ch 9, 1.5 General definitions and symbols

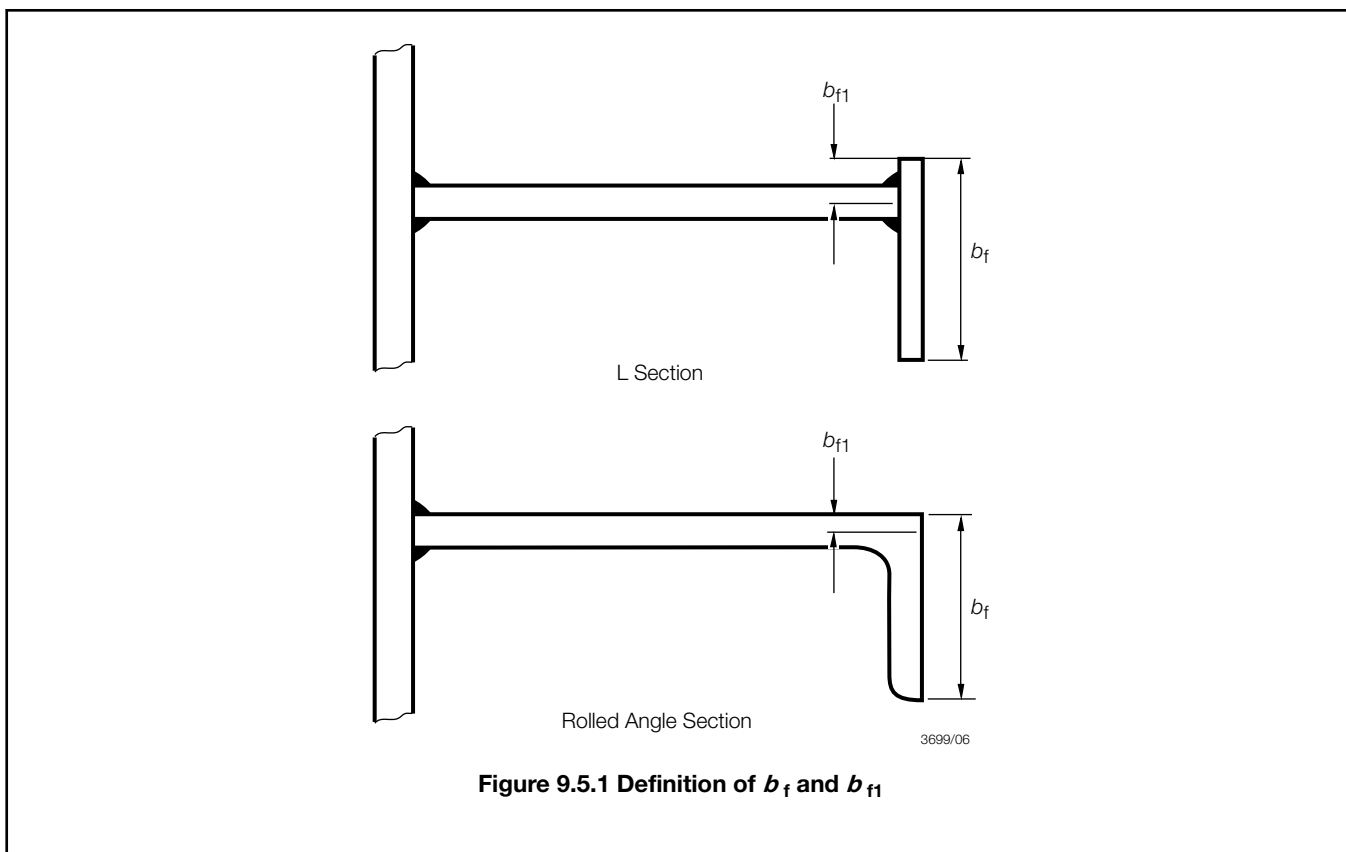

Figure 9.5.1 Definition of b_f and b_{f1}

5.3 Deck, side and bottom longitudinals

5.3.1 The modulus of longitudinals within the cargo tank region, except as provided for in Pt 4, Ch 9, 5.3 Deck, side and bottom longitudinals 5.3.2 and Pt 4, Ch 9, 5.5 Deck longitudinals outside 0,4L amidships is to be not less than the greater of the following:

- (a) $Z = 0,056s kh_1 l_e^2 F_1 F_s \text{ cm}^3$, or
- (b) $Z = 0,0051s kh_3 l_e^2 F_2 \text{ cm}^3$

where F_1 and F_2 values are as given in Table 9.5.1 Values of F1 and Table 9.5.2 Values of F2 and F_s is a fatigue factor to be taken as follows:

$$F_s = \frac{1,1}{k} \left[1 - \frac{2b_{f1}}{b_f} (1 - k) \right] \text{ at } 0,6D \text{ above the base line}$$

= 1,0 at upper deck at side and at the base line, intermediate values by linear interpolation

For flat bars and bulb plates $\frac{b_{f1}}{b_f}$ may be taken as 0,5

The modulus of side longitudinals need not exceed that of a bottom longitudinal having the same spacing and configuration.

Table 9.5.1 Values of F_1

Item	F_1
Deck longitudinals and side longitudinals above $\frac{D}{2}$	$\frac{Dc_1}{4D + 20h}$
Side longitudinal and bottom longitudinals below $\frac{D}{2}$	$\frac{Dc_1}{25D - 20h}$
NOTE Minimum $F_1 = 0,12$	

Table 9.5.2 Values of F_2

Item	F_2
Deck longitudinals and side longitudinals above $\frac{D}{2}$	$\frac{Dc_2}{D + 2,18h}$
Side longitudinal and bottom longitudinals below $\frac{D}{2}$	$\frac{Dc_2}{3,18D - 2,18h}$
NOTE Minimum $F_2 = 0,73$	

5.3.2 The modulus of bottom longitudinals is to satisfy the requirements of *Pt 4, Ch 9, 5.3 Deck, side and bottom longitudinals 5.3.1 or Table 1.6.1 (a) Shell framing (longitudinal)(3) in Pt 4, Ch 1 General Cargo Ships*, whichever is the greater.

5.3.3 The section modulus given is that of the longitudinal and associated plating, for the extent of the associated plating, see *Pt 3, Ch 3, 3.2 Geometric properties of section 3.2.3*. The webs and flanges are to comply with the minimum thickness requirements of *Pt 4, Ch 9, 10 Construction details and minimum thickness*.

5.3.4 Where the spacing of transverses exceeds 5,5 m, the scantlings of side and bottom longitudinals in way of bulkheads and primary members, including end connections, are to be verified by direct calculation.

5.3.5 The side and bottom longitudinal scantlings derived from *Pt 4, Ch 9, 5.3 Deck, side and bottom longitudinals 5.3.1 and Pt 4, Ch 9, 5.3 Deck, side and bottom longitudinals 5.3.2*, using the midship thickness of plating, are to extend throughout the cargo tanks. Where the shell plating is inclined at an angle to the horizontal longitudinal axis of greater than 10°, the span of the longitudinals is to be measured along the member. Where the shell plating is inclined at an angle to the vertical axis of greater than 10°, the spacing of longitudinals is to be measured along the chord between members. Where the angle of attachment of side longitudinals clear of amidships varies by 20° or more from a line normal to the plane of the shell, the properties of the section are to be determined about an axis parallel to the attached plating. Angles of slope greater than 40° are to be avoided.

5.3.6 Fabricated longitudinals having the face plate welded to the underside of the web, leaving the edge of the web exposed, are not recommended for shell, inner hull or longitudinal bulkhead longitudinals. Where it is proposed to fit such sections, a symmetrical arrangement of connection to transverse members is to be incorporated. This can be achieved by fitting backing brackets on the opposite side of the transverse web or bulkhead. The primary member web stiffener and backing bracket are to be lapped to the longitudinal. Recommended examples of such backing structure can be seen in the *ShipRight FDA Procedure, Structural Detail Design Guide (SDDG)*.

5.3.7 Where partial filling of the tanks is also contemplated the deck longitudinals are to comply with the requirements of *Pt 4, Ch 9, 6.1 General 6.1.2*.

5.3.8 Stiffeners and brackets on vertical webs in wing ballast tanks, where fitted on one side and connected to higher tensile steel longitudinals between the base line and 0,8D above the base line, are to have their heels well radiused to reduce stress concentrations. Where a symmetrical arrangement is fitted, i.e. bracket or stiffening on both sides, and they are connected to higher tensile steel longitudinals, the toes of the stiffeners or brackets are to be well radiused. Alternative arrangements will be considered if supported by appropriate fatigue life assessment calculations.

5.3.9 Where higher tensile steel side longitudinals pass through transverse bulkheads in the cargo area, well radiused brackets of the same material are to be fitted on both the fore and after side of the connection between the upper turn of bilge and 0,8D above the base line. Particular attention should be given to ensuring the alignment of these brackets. Alternative arrangements will be considered if supported by appropriate fatigue life assessment calculations.

Table 9.5.3 Determination of b_1

Item No.	Structural arrangement	Location	Value of b_1 , metres
1	Where wing and double bottom ballast tanks port and starboard are interconnected	(a) Bottom longitudinals	The greater horizontal distance from ship side to the longitudinal
		(b) Side longitudinals	Breadth of ship
		(c) Deck longitudinals	(i) In way of cargo tanks and inboard ballast tanks, the greater horizontal distance from tank corner at top of tank to longitudinal, either side (ii) In way of wing ballast tanks, the greater horizontal distance from ship side to longitudinal, either side
2	Where wing ballast tanks port and starboard are separate	(a) Bottom longitudinals	The horizontal distance from ship side to longitudinal
		(b) Side longitudinals	Width of wing ballast tank

5.4 Bilge longitudinals and brackets

5.4.1 The scantlings of bilge longitudinals are to be graduated between those required for the bottom and lowest side longitudinals.

5.4.2 Where bilge longitudinals are omitted, the spacing of transverses or equivalent bilge brackets must not exceed:

$$8 \times 10^6 \frac{t_s^2}{DR_B} \sqrt{\frac{t_s}{R_B}} \text{ mm}$$

Where no intermediate brackets are fitted between transverses, the spacing between the two outermost bottom longitudinals and between the two lowest side longitudinals is not to exceed one-third of the bilge radius or 40 times the local shell thickness, whichever is the greater.

5.4.3 Attention is drawn to *Pt 4, Ch 9, 4.6 Bilge plating 4.6.2* and *Pt 4, Ch 9, 4.6 Bilge plating 4.6.3* concerning bilge plating thickness where longitudinals are omitted.

5.5 Deck longitudinals outside 0,4L amidships

5.5.1 Within the cargo tank region, deck longitudinals may be gradually tapered outside 0,4L amidships in association with the deck plating, on the basis of area and modulus. For the requirements, see *Pt 3, Ch 3, 2.5 Taper requirements for hull envelope* and *Table 3.2.1 Taper requirements for hull envelope*, see also *Pt 4, Ch 9, 5.3 Deck, side and bottom longitudinals 5.3.5*.

5.5.2 The midship spacing of longitudinals is, in general, to be maintained throughout the cargo tank region. The plating thickness and longitudinal depth and thickness are not to be increased at any point in the direction of the taper of area towards the ends of the ship, other than as may be required for compensation for openings. Changes of longitudinal section are, in general, to be avoided.

5.5.3 Attention is also drawn to *Pt 4, Ch 9, 5.3 Deck, side and bottom longitudinals 5.3.3*, which is to be complied with, where necessary, by maintaining a constant deck plating thickness in way of the ends of the cargo tank region.

5.5.4 Where the spacing of transverses in cargo tanks is not constant and variations in longitudinal scantlings are contemplated to suit differing spans, individual consideration will be given to the taper arrangements.

5.6 Stability of longitudinals

5.6.1 The lateral and torsional stability of longitudinals together with web and flange buckling criteria are to be verified in accordance with *Pt 3, Ch 4, 7 Hull buckling strength*.

5.6.2 In addition, the following requirements are to be satisfied:

(a) Flat bar longitudinal

(i) when continuous at bulkheads

$$\frac{d_w}{t_w} \leq 18\sqrt{k_L}$$

(ii) when non-continuous at bulkheads

$$\frac{d_w}{t_w} \leq 15\sqrt{k_L}$$

(b) Built sections

(i)
$$\frac{d_w}{t_w} \leq 60\sqrt{k_L}$$

(ii)
$$\frac{b_f}{t_f} \leq 15$$
 for asymmetric sections

(iii)
$$\frac{b_f}{t_f} \leq 30$$
 for symmetric sections.

5.7 Connections of longitudinals

5.7.1 Connections of longitudinals to bulkheads are to provide adequate fixity and continuity of longitudinal strength. See also the *ShipRight FDA Procedure, Structural Detail Design Guide (SDDG)*, for recommended design details in critical areas.

5.7.2 Where the length of the ship exceeds 150 m, the longitudinals within 0,1D of the bottom and deck are to be continuous through the transverse bulkheads. Higher tensile steel longitudinals are to be continuous irrespective of ship length. Alternative arrangements will be individually considered.

5.7.3 Longitudinals are to be connected to transverse primary members as required by *Pt 3, Ch 10, 5.2 Arrangements at intersections of continuous secondary and primary members*.

5.8 Openings in longitudinals

5.8.1 In general, closely spaced scallops are not permitted in longitudinals within the range of cargo tanks except in way of ballast pipe suction, reinforcement in these areas will be specially considered.

5.8.2 Small air and drain holes, cut-outs at erection butts and similar widely spaced openings are, in general, to be not less than 200 mm clear of the toes of end brackets, intersections with primary supporting members and other areas of high stress. All openings are to be well rounded with smooth edges.

5.8.3 Drain holes in higher tensile steel longitudinals attached to higher tensile steel plating are to be elliptical in shape or of equivalent design to minimise stress concentrations. The opening is generally to be located clear of the welded connection to the plating, but where a flush opening is essential for drainage the weld connection is to end in a soft toe.

5.8.4 Small circular air holes may be arranged in higher tensile steel deck longitudinals.

5.8.5 Isolated openings spaced greater than 1 metre apart need not be taken into account in calculating the section modulus of the longitudinal, provided that the depth does not exceed 10 per cent of the web depth, or 75 mm, whichever is the greater, but in no case more than 25 per cent of the depth of the longitudinal.

5.8.6 Where the depths given in *Pt 4, Ch 9, 5.8 Openings in longitudinals 5.8.5* are exceeded, the arrangements are to be such as will minimise resultant stress concentration.

5.9 Transverse side frames

5.9.1 For limits of application of transverse side framing, see *Pt 4, Ch 9, 1.3 Class notation and applicable Rules for CSR Double Hull Oil Tankers*.

5.9.2 The section modulus of transverse side frames is to be not less than:

$$Z = 0,01025ksh_2 l_e^2 \text{ cm}^3, \text{ where side webs are fitted};$$

or

$$Z = 0,012ksh_2 l_e^2 \text{ cm}^3, \text{ where side webs are not fitted}.$$

5.9.3 The size of the frame is to be governed by the maximum modulus derived from the appropriate formula in *Pt 4, Ch 9, 5.9 Transverse side frames 5.9.2*, and is to be maintained for the full depth of the ship.

5.9.4 The section modulus given is that of the frame and associated side shell plating. The frame is to comply with the minimum thickness requirements of *Pt 4, Ch 9, 10 Construction details and minimum thickness*.

5.9.5 The inertia of transverse side frames is to be not less than:

$$\text{In the forward } 0,15L: I = 3,5I_e Z \text{ cm}^4$$

$$\text{Elsewhere: } I = 3,2I_e Z \text{ cm}^4.$$

■ Section 6

Inner hull, inner bottom and longitudinal oiltight bulkheads

6.1 General

6.1.1 The inner hull, inner bottom and longitudinal bulkheads are generally to be longitudinally framed. Longitudinal bulkheads may be plane or horizontally corrugated. Centreline longitudinal bulkheads may also be vertically corrugated, see *Pt 4, Ch 9, 1.4 Class notation and applicable Rules for non-CSR Double Hull Oil Tankers 1.4.14*. Scantlings of inner hull and longitudinal oiltight bulkheads are to be in accordance with *Table 9.6.1 Inner hull and longitudinal oiltight bulkhead scantlings* and panel stability is also to be confirmed from primary structure direct calculations. The calculation is to take account of the shear stress and direct stresses derived from both the transverse and longitudinal strength investigations.

Table 9.6.1 Inner hull and longitudinal oiltight bulkhead scantlings

Item	Horizontally stiffened/Vertically stiffened
(1) Plating thicknesses including corrugations (mm) See Notes 1 and 7	(a) Within 0,1D of the deck: $t = t_0$ (b) Within 0,1D of the bottom shell: $t = \frac{t_0}{\sqrt{2 - F_B}}$ (but not less than t_1) (c) Elsewhere: $t = t_1$ see Note 6 (d) But not less than $t = 0,0009s (0,059L_{1+7})$
(2) Stiffener modulus (cm ³) See Notes 3 and 4	(a) Horizontally stiffened: (i) $Z = 0,056kh_2 s l_e^2 F_1$ whichever is the greater (ii) $Z = 0,0051kh_4 s l_e^2 F_2$ whichever is the greater (b) Vertically stiffened: $Z = 0,0067ks l_e^2 h_5$
(3) Corrugation properties See Note 7	(a) Modulus (cm ³): $Z = 0,0085ph s l_e^2 k$ (b) Inertia (cm ⁴): $I = 0,032ph s l_e^3$

Note 1. The plating thicknesses are not to be less than as necessary to comply with the buckling requirements of Pt 3, Ch 4, 7 Hull buckling strength.

Note 2. The section modulus given by the formula is that of the stiffener and associated plating or of the corrugation over pitch, p .

Note 3. For vertical stiffeners, the ratio of web depth to web thickness is not to exceed $60\sqrt{k}$ for stiffeners with flanges or face plates, and $18\sqrt{k}$ for flat bars. Horizontal stiffeners are to comply with Pt 4, Ch 9, 5.6 Stability of longitudinals.

Note 4. The minimum thickness criteria given in Pt 4, Ch 9, 10 Construction details and minimum thickness are also to be complied with and the stiffener web thickness is to be sufficient to withstand the imposed shear forces.

Note 5. The minimum moment of inertia represented by item 3(b) of the Table is not to be reduced on account of higher tensile steel being incorporated.

Note 6. In applying item 1(c) of the Table, it is necessary to calculate values of t_0 for plate panels within 0,4D each side of mid-depth, take the minimum value, t_m , and then determine value of t_1 .

Note 7. For vertically corrugated centreline longitudinal bulkheads see also Table 1.9.2 in Pt 4, Ch 1 General Cargo Ships for deep tanks.

6.1.2 Where tanks are intended to be partially filled, the scantlings and structural arrangements of the boundary bulkheads are to be capable of withstanding the loads imposed by the movement of liquid in the tanks. The magnitude of the predicted loadings, together with the scantling calculations, may require to be submitted.

6.2 Symbols

6.2.1 The symbols used in this Section are defined as follows:

b_1 = the greater horizontal distance, in metres, from a point one third of the height of the strake above its lower edge or mid-point of the stiffener span, to the corners at the top of the tank on either side.

Where the angle α is less than $\left(32,5 - \frac{L}{20}\right)$ degrees, the distance is measured to the widest point of the tank, see *Figure 9.6.1 Illustration of b_1 determination*.

α = angle, in degrees, as indicated in *Figure 9.6.1 Illustration of b_1 determination*.

$$c_1 = \frac{60}{225 - 165F_D} \text{ at deck}$$

$$= 1,0 \text{ at } \frac{D}{2}$$

$$= \frac{75}{225 - 150F_B} \text{ at base line of ship}$$

intermediate values of c_1 by interpolation

$$c_2 = \frac{165}{345 - 180F_D} \text{ at deck}$$

$$= 1,0 \text{ at } \frac{D}{2}$$

$$= \frac{165}{345 - 180F_B} \text{ at base line of ship}$$

intermediate values of c_2 by interpolation

h = load height, in metres measured vertically as follows:

(a) For bulkhead plating, the distance from a point one third of the height of the plate panel above its lower edge to the highest point of the tank, excluding hatchway

(b) for bulkhead stiffeners or corrugations, the distance from the mid-point of span of the stiffener or corrugation to the highest point of the tank, excluding hatchway

$$h_1 = \left(h + \frac{D_1}{8}\right), \text{ but not less than } 0,72(h + Rb_1)$$

$$h_2 = \left(h + \frac{D_1}{8}\right), \text{ in metres, but in no case to be taken less than } \frac{L_1}{56} \text{ m or } (0,01L_1 + 0,7) \text{ m, whichever is the greater}$$

h_3 = distance of longitudinal below deck at side, in metres, but is not to be less than 0

$$h_4 = h + Rb_1$$

$$h_5 = h_2 \text{ but is to be not less than } 0,55h_4$$

l_e = effective length, in metres, of longitudinals measured between span points, but is not to be taken less than 2,5 m. For determination of span points, see *Pt 3, Ch 3, 3 Structural idealisation*

p = pitch of symmetrical corrugations, in mm

s = spacing, in mm, of bulkhead stiffeners for plane bulkheads. In case of symmetrical corrugations, s is to be taken as b or c in *Figure 3.3.1 Corrugation dimensions* in *Pt 3, Ch 3 Structural Design*, whichever is the greater

$$t_0 = 0,005s \sqrt{kh_1}$$

$$t_1 = t_0 \left(0,84 + 0,16 \left(\frac{t_m}{t_0} \right)^2 \right)$$

t_m = minimum value of t_0 within $0,4D$ each side of mid-depth of bulkhead

D_1 = D , in metres, but is to be taken not less than 10 and need not be taken greater than 16

F_B = as defined in Pt 3, Ch 4, 5.7 Local reduction factors

F_D = as defined in Pt 3, Ch 4, 5.7 Local reduction factors

F_1 = a factor determined from Table 9.6.2 Values of F_1

F_2 = a factor determined from Table 9.6.3 Values of F_2

$$R = \sin \theta$$

where θ is the roll angle, in degrees

$$\text{and } \sin \theta = \left(0,45 + 0,1 \frac{L}{B} \right) \left(0,54 - \frac{L}{1270} \right)$$

Other symbols are defined in Pt 4, Ch 9, 1.5 General definitions and symbols.

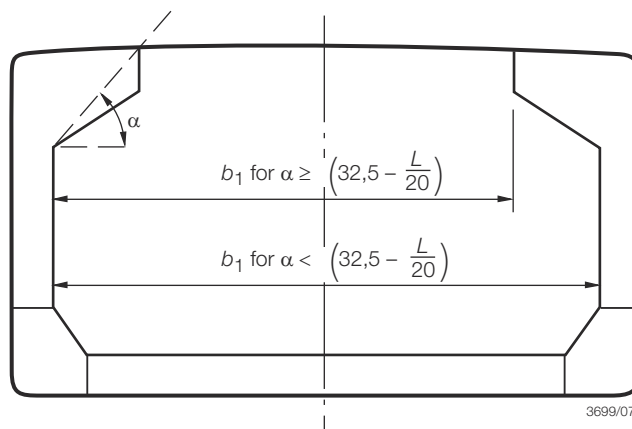

Figure 9.6.1 Illustration of b_1 determination

Table 9.6.2 Values of F_1

Longitudinal bulkhead longitudinals	F_1
Above $\frac{D}{2}$	$\frac{Dc_1}{4D + 20h_3}$
Below $\frac{D}{2}$	$\frac{Dc_1}{25D - 20h_3}$
Note Minimum $F_1 = 0,12$	

Table 9.6.3 Values of F_2

Longitudinal bulkhead longitudinals	F_2
Above $\frac{D}{2}$	$\frac{Dc_2}{D + 2,18h_3}$
Below $\frac{D}{2}$	$\frac{Dc_2}{3,18D - 2,18h_3}$
Note Minimum $F_2 = 0,73$	

6.3 Inner hull and longitudinal bulkheads

6.3.1 Inner hull and longitudinal bulkheads are to extend as far forward and aft as practicable and are to be effectively scarfed into the adjoining structure.

6.3.2 Longitudinal bulkheads only may be perforated provided suitable account is taken of the applied shear forces. Proposals to fit perforated longitudinal bulkheads in cargo tanks will be individually considered. See also Pt 4, Ch 9, 7.1 General concerning penetration of pump-room, cofferdam and cargo tank bulkheads.

6.3.3 The thickness of inner hull and longitudinal bulkhead plating required by Table 9.6.1 Inner hull and longitudinal oiltight bulkhead scantlings is to be maintained throughout the cargo tank length, with the exception of item (1)(a) which may be gradually tapered outside 0,4L amidships to cargo tank minimum thickness or as required by item (1)(c), whichever is the greater, at 0,075L from the ends.

6.3.4 The bulkhead plating thicknesses throughout the cargo tank length are to be increased as necessary to attain compliance with the shear strength requirements of Pt 3, Ch 4, 6 Hull shear strength .

6.3.5 For conditions which provide for wing and centre cargo tanks abreast to be filled, with adjacent cargo tanks fore and aft empty, the thickness of longitudinal bulkheads is to comply with the requirements of Pt 4, Ch 9, 8.3 Scantlings 8.3.2 and Pt 4, Ch 9, 8.3 Scantlings 8.3.2, see also Pt 4, Ch 9, 3.3 Loading conditions 3.3.6.

6.3.6 Where bulkheads are penetrated by cargo or ballast piping, the structural arrangements in way are to be capable of withstanding the loads imparted to the bulkheads by the hydraulic forces in the pipes. The requirements for cargo and ballast piping is given in Pt 5, Ch 15, 2.5 Air and sounding pipes and Pt 5, Ch 15, 3 Cargo handling system.

6.3.7 Openings in horizontal stiffeners are to comply with the requirements of Pt 4, Ch 9, 5.8 Openings in longitudinals.

6.4 Longitudinal corrugated bulkheads

6.4.1 Where horizontally corrugated bulkheads are adopted the angle of corrugation is to be not less than 40°.

6.4.2 In ships exceeding 150 m in length the upper and lower strakes of the longitudinal bulkhead are to be plane for a distance of 0,1D from the deck and bottom.

6.4.3 Corrugations are to be aligned, and stiffening arrangements on plane members are to be arranged to give adequate support in way of flanges of abutting corrugations. Where both the longitudinal and transverse bulkheads are horizontally corrugated, the arrangements at intersections are to be designed to facilitate attachment and maintain continuity.

6.4.4 Where asymmetrical girders or webs are fitted to corrugated bulkheads, the angle of corrugation is not to exceed 60°.

6.5 Inner bottom

6.5.1 The inner bottom is to be longitudinally framed and the inner bottom plating thickness is to be not less than the greater of:

(a) $t = \frac{t_0}{\sqrt{2 - F_B}}$ mm , or

(b) deep tank requirements of Table 1.9.1 Watertight and deep tank bulkhead scantlings in Pt 4, Ch 1 General Cargo Ships.

6.5.2 The section modulus of inner bottom longitudinals is to be in accordance with *Table 9.6.1 Inner hull and longitudinal oiltight bulkhead scantlings* or deep tank requirements of *Table 1.9.1 Watertight and deep tank bulkhead scantlings* in *Pt 4, Ch 1 General Cargo Ships*, whichever is the greater, and the unsupported span may extend to the spacing between plate floors.

6.5.3 Buckling resistance to longitudinal and transverse stresses in the inner bottom is to be confirmed by direct calculation, see also *Pt 3, Ch 4, 7 Hull buckling strength*.

6.5.4 Transverse continuity of inner bottom is to be maintained outboard of inner hull, see *Pt 4, Ch 9, 6.6 Hopper side tank*
6.6.3. Recommended details are shown in the *ShipRight FDA Procedure, Structural Detail Design Guide (SDDG)*.

6.5.5 Particular attention is to be given to the through thickness properties and continuity at the connection of bulkhead stools to the inner bottom. For requirements for plates with specified through thickness properties, see *Ch 3, 8 Plates with specified through thickness properties* of the Rules for Materials.

6.5.6 Connection of inner bottom longitudinals to plate floor is to satisfy the requirements given in *Pt 3, Ch 10, 5.2 Arrangements at intersections of continuous secondary and primary members*.

6.6 Hopper side tank

6.6.1 Where a hopper side tank is fitted the sloping bulkhead plating and attached longitudinals are to be as required by *Table 9.6.1 Inner hull and longitudinal oiltight bulkhead scantlings*.

6.6.2 A transverse is to be arranged in the hopper tank in line with each double bottom plate floor, to ensure continuity of transverse strength.

6.6.3 Particular attention is to be paid to the continuity of the inner bottom plating into the hopper side tank. Scarfing brackets are to be fitted in the hopper in line with the inner bottom at each transverse. These brackets are to be arranged each side of the transverse.

6.6.4 Knuckles in the hopper tank plating are to be supported by side girders and stringers or by a deep longitudinal.

6.6.5 Detail design guidelines for connections in way of hopper tank knuckles are shown in the *ShipRight FDA Procedure, Structural Detail Design Guide (SDDG)*.

6.7 Connections

6.7.1 Horizontal and vertical stiffeners are to be connected to supporting primary members as required by *Pt 3, Ch 10, 5.2 Arrangements at intersections of continuous secondary and primary members*.

6.7.2 Stiffeners are to be bracketed or otherwise efficiently connected at their ends to provide adequate fixity, as required by *Pt 3, Ch 10 Welding and Structural Details*.

6.7.3 Connections of horizontal stiffeners to transverse bulkheads are to provide adequate fixity and continuity of longitudinal strength. Horizontal stiffeners are to be continuous through bulkheads as required by *Pt 4, Ch 9, 5.7 Connections of longitudinals*, for longitudinals.

6.7.4 Where inner hulls, longitudinal and transverse bulkheads are horizontally stiffened, consideration will be given to the stability of the arrangements at intersections. Additional calculations may be required.

■ Section 7 **Transverse oiltight bulkheads**

7.1 General

7.1.1 Transverse oiltight bulkheads may be plane or with corrugations arranged horizontally or vertically. Scantlings are to be in accordance with *Table 9.7.1 Transverse oiltight bulkhead scantlings*, except as otherwise provided for in this Section. The arrangement of stiffening is to be such as will efficiently support loads transmitted by end connections of inner hull, longitudinal bulkhead, shell and deck longitudinals. The thickness of bulkhead plating is also to be confirmed by direct calculation in respect of panel stability. The calculation is to take account of the shear stresses and direct stresses derived from both the transverse and longitudinal strength investigations.

7.1.2 Where tanks are intended to be partially filled, the scantlings and structural arrangements of the boundary bulkheads are to be capable of withstanding the loads imposed by the movement of liquid in the tanks. The magnitude of the predicted loadings, together with the scantling calculations, may require to be submitted.

7.1.3 The scantlings of water ballast tank and cofferdam bulkheads not forming the boundary of a cargo tank are to be as required by *Pt 4, Ch 1, 9 Bulkheads* for deep tanks. Where the bulkheads are boundaries of 'U' shaped tanks, the scantlings are also to be confirmed by the requirements of this Section.

Table 9.7.1 Transverse oiltight bulkhead scantlings

Item	Horizontally stiffened	Vertically stiffened
(1) Plating thickness (mm)	$t = 0,0044sf \sqrt{kh_1}$	
(a) Generally, including corrugations see also item 3		
(b) But not less than:		
For the upper $\frac{3}{4}$ of the bulkhead see Note 5	$t = \frac{a}{(95 + 20\frac{a}{b})\sqrt{k}}$	$t = \frac{a}{(85 + 30(\frac{a}{b})^2)\sqrt{k}}$
For the lower $\frac{1}{4}$ of the bulkhead see Note 5	$t = \frac{a}{(80 + 20\frac{a}{b})\sqrt{k}}$	$t = \frac{a}{(73 + 27(\frac{a}{b})^2)\sqrt{k}}$
(2) Stiffener modulus (cm ³)	$Z = 0,0067ks S_1^2 h_2$	
(3) Corrugation properties		
(a) Modulus (cm ³)	$Z = 0,0085ph_2 e^2 k$	
(b) Inertia (cm ⁴) see Note 4	$I = 0,032ph_2 e^3$	
<p>Note 1. The section modulus given by the formula is that of the stiffeners and associated plating or of the corrugation over pitch p.</p> <p>Note 2. The ratio of web depth to web thickness is not to exceed $60 \sqrt{k}$ for stiffeners with flanges or face plates and $18 \sqrt{k}$ for flat bars.</p> <p>Note 3. The minimum thickness criteria given in <i>Pt 4, Ch 9, 10 Construction details and minimum thickness</i> are also to be complied with, and the stiffener web thickness is to be sufficient to withstand the imposed shear forces.</p> <p>Note 4. The minimum moment of inertia required by item 3(b) of the Table is not to be reduced on account of higher tensile steel being incorporated.</p> <p>Note 5. For vertically corrugated bulkheads see <i>Table 1.9.2 Symmetrical corrugations and double plate bulkheads (additional requirements)</i> in <i>Pt 4, Ch 1 General Cargo Ships</i> for deep tanks.</p>		

7.1.4 Where the pump-room acts as a cofferdam, a bulkhead which does not form part of the boundary of a cargo tank or a fuel oil bunker may be of watertight bulkhead scantlings in accordance with the requirements of *Pt 4, Ch 1, 9 Bulkheads* provided that an inert gas system is fitted in the cargo tanks, and the corresponding notation provided for in *Pt 1, Ch 2, 2 Character of classification and class notations* is assigned.

7.1.5 Where penetration of the cofferdam or pump-room bulkheads is permitted by the Rules, the integrity of the bulkhead is to be maintained, see also *Pt 5, Ch 13, 2 Construction and installation, Pt 5, Ch 15, 3 Cargo handling system* and *Pt 6, Ch 2, 14 Electrical equipment for use in explosive gas atmospheres or in the presence of combustible dusts*.

7.1.6 Where bulkheads are penetrated by cargo or ballast piping, the structural arrangements in way are to be capable of withstanding the loads imparted to the bulkheads by the hydraulic forces in the pipes.

7.1.7 Special consideration will be given to any proposals to fit permanent repair/maintenance access openings with oiltight covers in cargo tank bulkheads. Attention is drawn to the existence of National Authority Regulations concerning load line and oil outflow aspects of such arrangements.

7.2 Symbols

7.2.1 The symbols used in this Section are defined as follows:

a = the lesser dimension of an unstiffened plate panel, in mm

b = the greater dimension of an unstiffened plate panel, in mm

b_1 = the greater horizontal distance, in metres, from the centre of the plate panel or mid-point of the stiffener span to the corners at the top of the tank on either side.

$$f = 1,1 - \frac{s}{2500S_1} \text{ but not to be taken greater than } 1,0$$

h = load height, in metres measured vertically as follows:

- (a) for bulkhead plating, the distance from a point one-third of the height of the plate panel above its lower edge to the highest point of the tank, excluding hatchway
- (b) for bulkhead stiffeners or corrugations, the distance from the mid-point of span of the stiffener or corrugation to the highest point of the tank, excluding hatchway

$$h_1 = h + \frac{D_1}{8} \text{ but not less than } 0,72 (h + Rb_1)$$

$$h_2 = h + \frac{D_1}{8} \text{ but not less than } 0,55 (h + Rb_1)$$

p = pitch of symmetrical corrugations, in mm

s = spacing, in mm, of bulkhead stiffeners or the breadth, in mm, of flange or web, whichever is the greater, of symmetrical corrugations

$D_1 = D$, in metres, but is to be taken not less than 10 and need not be taken greater than 16

$R = \sin\theta$

where θ is the roll angle, in degrees

$$\text{and } \sin \theta = \left(0,45 + 0,1 \frac{L}{B}\right) \left(0,54 - \frac{L}{1270}\right)$$

S_1 = spacing of primary members, in metres. For the span at top, span may be reduced by the depth of deck longitudinal.

Other symbols are defined in *Pt 4, Ch 9, 1.5 General definitions and symbols*

7.3 Corrugated bulkheads

7.3.1 Where corrugated bulkheads are adopted the angle of corrugation is to be not less than 40°, see *Figure 3.3.1 Corrugation dimensions in Pt 3, Ch 3 Structural Design*.

7.3.2 Where transverse bulkheads are vertically corrugated, adequate resistance to transverse compressive forces is to be provided by horizontal stringers or equivalent.

7.3.3 Where transverse bulkheads are horizontally corrugated, the span of the corrugations should not, in general, exceed 5,0 m. Consideration is to be given to providing an efficient connection between the corrugations and the inner hull and longitudinal bulkhead stiffeners including local reinforcement where necessary.

7.3.4 Corrugations are to be aligned and stiffening arrangements on plane members are to be arranged to give adequate support in way of flanges of abutting corrugations. Where both the longitudinal and transverse bulkheads are horizontally corrugated, the arrangements at intersections are to be designed to facilitate attachment and maintain continuity.

7.3.5 Where asymmetrical girders or webs are fitted to corrugated bulkheads, the angle of corrugation is not to exceed 60°.

7.3.6 Where corrugated bulkheads on stools are adopted, attention is to be paid to the design of end connection. The arrangements are to be in accordance with the requirements of *Pt 4, Ch 9, 7.4 Bulkheads supported by stools*.

7.3.7 Where vertically corrugated bulkheads are proposed without stools both flanges are to be adequately supported at deck and inner bottom. Proposals will be specially considered. Particular attention is to be given to the through thickness properties of the inner bottom plating and continuity at the connection to the inner bottom. For the requirements for plates with specified through thickness properties, see *Ch 3, 8 Plates with specified through thickness properties* of the Rules for Materials.

7.4 Bulkheads supported by stools

7.4.1 The scantlings of vertically corrugated and double plate bulkheads supported by stools are generally to be confirmed by direct calculations which are to be submitted.

7.4.2 In addition the scantlings are to be determined in accordance with the requirements of *Pt 4, Ch 1, 9.2 Watertight and deep tank bulkheads 9.2.1* for deep tank bulkheads with the load head h_4 , in metres, measured to the highest point of the tank, excluding hatchway, but is not to be taken less than $0,44 (h_4 + Rb_1)$.

7.4.3 The sloping stool plate thickness adjacent to the corrugation is to be not less than the thickness of the corrugation flange at mid span as required by *Pt 4, Ch 9, 7.4 Bulkheads supported by stools 7.4.1* and *Pt 4, Ch 9, 7.4 Bulkheads supported by stools 7.4.2*. Where the plate thickness is increased locally, the vertical extent is to be not less than the width of the flange of the corrugation.

7.4.4 The stools are to be reinforced with plate diaphragms or deep webs, and in bottom stools the diaphragms are to be aligned with double bottom side girders. Continuity is also to be maintained between the diaphragms and the webs of bulkhead corrugations as far as practicable.

7.4.5 Additional double bottom girders are to be arranged extending at least to the first plate floor adjacent to the bulkhead each side and, in general, are to be spaced not more than 3,8 m apart.

7.4.6 The sloping plate of bottom stools is to be aligned with double bottom floors. Particular attention is to be given to the through thickness properties of the inner bottom plating and continuity at the connection to the inner bottom, and to the through thickness properties of the bottom stool shelf plate. For requirements for plates with specified through thickness properties see *Ch 3, 8 Plates with specified through thickness properties* of the Rules for Materials.

7.4.7 An efficient system of reinforcement is to be arranged in line with the tank transverse bulkheads or bulkhead stools at the intersection with the sloped plating of the double bottom hopper tanks and topside tanks. The reinforcement fitted in the tanks is to consist of girders or intercostal bulb plate or equivalent stiffeners fitted between and connected to the sloped bulkhead longitudinals.

7.4.8 The shelf plates of the bulkhead stools are to be arranged to align with the longitudinals in the double bottom hopper tank and topside tanks. Where sloping shelf plates are fitted to stools suitable scarfing is to be arranged in way of the connections of the stools to the adjoining structures.

7.4.9 The arrangement of stools and adjacent structure common with the cargo tank is to be designed to avoid pockets in which gas could collect.

7.5 Connections

7.5.1 Horizontal and vertical stiffeners are to be connected to supporting primary members as required by *Pt 3, Ch 10, 5.2 Arrangements at intersections of continuous secondary and primary members*.

7.5.2 Stiffeners are to be bracketed or otherwise efficiently connected at their ends to provide adequate fixity.

7.5.3 Arrangements and scantlings of end brackets for vertical stiffeners are to be as required by *Pt 3, Ch 10 Welding and Structural Details*.

7.5.4 Horizontal stiffener end brackets are generally to satisfy the requirements of *Pt 3, Ch 10 Welding and Structural Details*. However, the length of the bracket arm at the side shell, inner hull and longitudinal bulkhead longitudinals is, in general, not to exceed the depth of the longitudinal. In order to provide the necessary weld connection, consideration may require to be given to fitting brackets on both sides of the bulkhead or to welding the stiffener to the longitudinal. The arrangements are also to be such as to maintain transverse continuity at intersections. Examples can be seen in the *ShipRight FDA Procedure, Structural Detail Design Guide*, (SDDG), published by LR.

■ Section 8 Non-oiltight bulkheads

8.1 General

8.1.1 The requirements of this Section are applicable to longitudinal and transverse wash bulkheads, where fitted. Proposals to fit perforated longitudinal bulkheads in cargo tanks will be individually considered, *see also Pt 4, Ch 9, 1.3 Class notation and applicable Rules for CSR Double Hull Oil Tankers.*

8.1.2 Wash bulkheads are generally to be of plane construction, horizontally or vertically stiffened, having an area of perforations not less than 10 per cent of the total area of the bulkhead. The perforations are to be so arranged that the efficiency of the bulkhead as a support is not impaired.

8.1.3 Where tanks are intended to be partially filled, the scantlings and structural arrangements of the wash bulkheads are to be capable of withstanding the loads imposed by the movement of liquid in the tanks. The magnitude of the predicted loads, together with the scantling calculations, may require to be submitted.

8.2 Symbols

8.2.1 The symbols used in this Section are defined as follows:

a = the horizontal length of the plate panel, in mm

a_T = the cross-sectional area of the vertical web on longitudinal bulkhead and associated bulkhead plating over one transverse space, in cm^2

b_I = half the distance, in metres, between members supporting floors as shown in *Figure 9.8.1 Horizontal girder*

b_L = half the distance, in metres, between members supporting horizontal girder, adjacent to the bulkhead under consideration, as shown in *Figure 9.8.1 Horizontal girder*

b_T = overall breadth of tank, in metres

$D_I = D$, in metres, but is to be taken not less than 10 and need not be taken greater than 16

D_L = the depth of the longitudinal bulkhead, including double bottom girder, in metres

d_L = the distance, in metres, from the top of the longitudinal bulkhead to the centre of the plate panel under consideration and need not be taken greater than the distance to the bracket toe of the double bottom transverse primary member

h = the distance, in metres, from the centre of the load on the horizontal girder to $\frac{D_I}{8}$ m above the highest point of the tank, excluding the hatchway

d_H = the mean depth of horizontal girders at the longitudinal bulkhead, in metres, including the depth of the end brackets as shown in *Figure 9.8.1 Horizontal girder*

l_G = the distance, in metres, from the horizontal girders to the adjacent horizontal primary member below

$$t_3 = \frac{(Q_{SL} + Q_{SW})}{D_L \tau} \text{ mm}$$

Q_S, Q_W = as defined in *Pt 3, Ch 4, 6.1 Symbols*

$$\tau = \frac{110}{k_L} \text{ N/mm}^2 \quad \left(\frac{11,2}{k_L} \text{ kgf/mm}^2 \right)$$

Q_{SL} = the maximum still water shear force on the longitudinal bulkhead, in kN (tonne-f), of the loading condition in question.

= Where two longitudinal bulkheads are fitted, Q_{SL} may be taken as:

$$= Q_{SL} = 0,34Q_S$$

= Where one longitudinal bulkhead is fitted, Q_{SL} may be taken as:

$$= Q_{SL} = 0,40Q_S$$

= Q_{SL} may also be derived by direct calculation to determine the distribution of shear force between the shell, inner hull and longitudinal bulkheads.

Q_{SW} = design wave shear force on the longitudinal bulkhead, in kN (tonne-f).

= Where two longitudinal bulkheads are fitted, Q_{SW} may be taken as:

$$= Q_{SW} = 0,20Q_w$$

= Where one longitudinal bulkhead is fitted, Q_{SW} may be taken as:

$$= Q_{SW} = 0,28Q_w$$

l_T = overall length of tank, in metres

$$F_d = W_h S b_i \frac{d_L}{D_L}$$

l_b = the distance between the transverse bulkheads (oiltight or non-oiltight) adjacent to the bulkhead under consideration, in metres

S = spacing of the double bottom transverse primary members, in metres

T_p = the maximum operating draught of ship, in metres, where the tank with non-oiltight bulkhead is empty.

$$W_h = T_p + 0,023L e^{-0,0044L}$$

$$a = \frac{s}{a}, \text{ but not to be taken greater than } 1,0$$

Other symbols are defined in *Pt 4, Ch 9, 1.5 General definitions and symbols*.

8.3 Scantlings

8.3.1 The thickness of plating may be the compartment minimum, see *Pt 4, Ch 9, 10 Construction details and minimum thickness*, except as given in *Pt 4, Ch 9, 8.3 Scantlings 8.3.2* and *Pt 4, Ch 9, 8.3 Scantlings 8.3.4*.

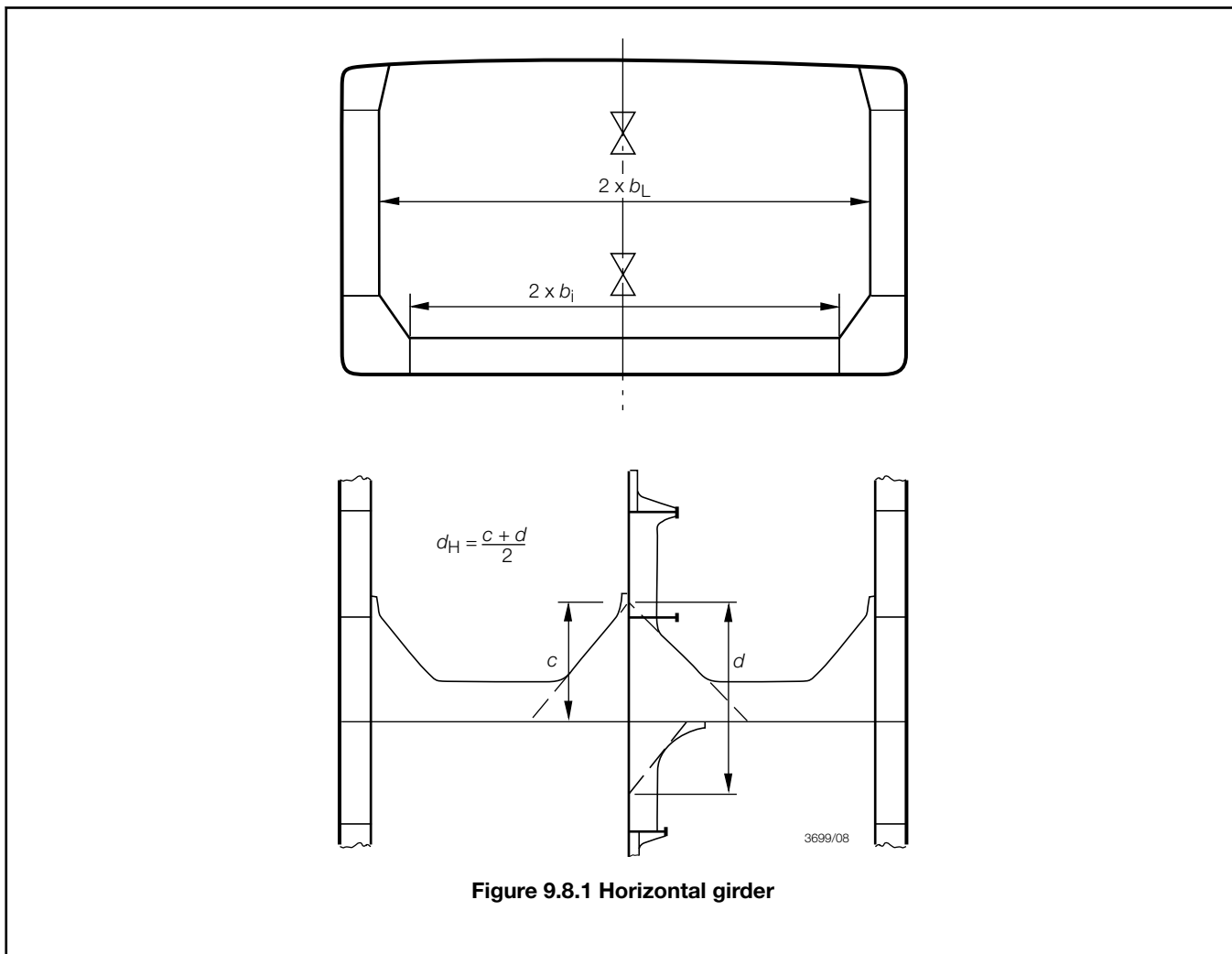

Figure 9.8.1 Horizontal girder

8.3.2 Where non-oiltight **longitudinal** wash bulkheads support a bottom primary member, the following additional requirements are to be met:

- (a) The area of perforation is to be not greater than 25 per cent of the total area of the bulkhead, and consideration is to be given to the disposition and geometry of the perforations so that the shear rigidity of the bulkhead is a maximum.
- (b) The net section area of the bulkhead is to be not less than $0,135 I_T b_T D$ cm².
- (c) The plating thickness is to comply with *Table 9.6.1 Inner hull and longitudinal oiltight bulkhead scantlings (1)(d)*.
- (d) The thickness of longitudinal bulkhead plating and web plating of the vertical web on longitudinal bulkhead is generally to be not less than:

$$t = 0,026 \frac{s}{1 + \alpha^2} \sqrt{\frac{F_d}{a_T}} \text{ mm}$$

- (e) The thickness of the longitudinal bulkheads supporting a transverse bulkhead horizontal girder is in general to be not less than:

$$(i) \quad t = \frac{0,0437 h l_G b_L k}{d_H} + \frac{0,892 t_3 k}{k_L} \text{ mm}$$

$$(ii) \quad t = 0,0011s(0,059L_1 + 7) \text{ mm}$$

whichever is the greater.

The thickness is also to satisfy the buckling requirements of *Pt 3, Ch 4, 7 Hull buckling strength*.

The increased thickness is to extend over the end bracket and buttress of the horizontal girder down to a distance of $0,5l_G$.

8.3.3 The section modulus of longitudinal wash bulkhead stiffeners is to be not less than, see also *Pt 3, Ch 4, 7 Hull buckling strength*:

$$Z = 0,0036 \left(0,54 - \frac{L}{1270} \right) b_T k_s S^2 \quad \text{cm}^3$$

8.3.4 Where non-oiltight **transverse** wash bulkheads support a primary fore and aft bottom centreline girder, the following additional requirements are to be met:

- (a) The area of perforation is to be not greater than 25 per cent of the total area of the bulkhead, and consideration is to be given to the disposition and geometry of the perforations so that the shear rigidity of the bulkhead is a maximum.
- (b) The net section area of the bulkhead is to be not less than $0,135 l_b b_T D \text{ cm}^2$.
- (c) The plating thickness is to comply with *Table 9.7.1 Transverse oiltight bulkhead scantlings*(1)(b). In no case is either panel dimension to exceed 180 times the thickness required by this sub-paragraph or by *Pt 4, Ch 9, 8.3 Scantlings 8.3.1*, whichever is the greater.

8.3.5 The section modulus of transverse wash bulkhead stiffeners is to be not less than:

$$Z = 0,1215 k_s l_e \frac{l_b}{2L} \quad \text{cm}^3$$

8.4 Connections

8.4.1 Stiffeners are to be bracketed or otherwise efficiently connected at their ends and to primary supporting members, in accordance with the requirements of *Pt 3, Ch 10 Welding and Structural Details*.

■ Section 9 Primary members supporting longitudinal framing

9.1 General

9.1.1 These requirements are applicable to ships having structural arrangements in accordance with *Pt 4, Ch 9, 1.4 Class notation and applicable Rules for non-CSR Double Hull Oil Tankers*.

9.1.2 The minimum thickness and constructional detail requirements of *Pt 4, Ch 9, 10 Construction details and minimum thickness* are also to be complied with.

9.1.3 The scantlings of primary members are, in general, to be determined from direct calculations carried out in accordance with the requirements of *Pt 4, Ch 9, 14 Direct calculations* or in accordance with the requirements of this Section or the relevant Sections of *Pt 4, Ch 10 Single Hull Oil Tankers*. The direct calculations are to be submitted with the plans for confirmatory purposes, see also *Pt 4, Ch 9, 1.4 Class notation and applicable Rules for non-CSR Double Hull Oil Tankers 1.4.5*.

9.2 Symbols

9.2.1 The symbols used in this Section are defined as follows:

b_{e1}, b_{e2} = effective end bracket leg length, in metres, at each end of the member, see *Pt 3, Ch 3, 3 Structural idealisation*

d_{DB} = Rule depth of centre girder, in mm

h_c = vertical distance from the centre of the cross-ties to deck at side amidships, in metres

h_s = distance between the lower span point of the vertical web and the moulded deck line at centreline, in metres

l_b = the distance, in metres, between the transverse bulkheads (oiltight or non-oiltight) adjacent to the bulkhead under consideration

l_c = one-half the vertical distance, in metres, between the centres of the adjacent cross-ties or between the centre of the adjacent cross-tie and the centre of the adjacent bottom or deck transverse, or double bottom, see *Figure 9.9.1 Wing tank construction*

s = spacing of transverses, in metres

A_c = cross sectional area of the cross-tie material which is continuous over the span of the cross-tie in cm^2

I_c = least moment of inertia of the cross-tie in cm^4

S_c = length of cross-tie, in metres, measured as follows:

(a) For centre tank cross-ties: S_c is the distance between the face plates of the vertical webs on the longitudinal bulkheads.

(b) For wing tank cross-ties: S_c is the distance between the face plate of the vertical web on the longitudinal bulkhead and the inner hull

S_s = span of the vertical web, in metres, and is to be measured between end span points, see *Figure 9.9.1 Wing tank construction*.

Other symbols are defined in *Pt 4, Ch 9, 1.5 General definitions and symbols*.

9.3 Girders and floors in double bottom

9.3.1 Girders are to be arranged at the centreline or duct keel, at the hopper side and in way of longitudinal bulkheads and bulkhead stools. Plate floors are to be arranged in way of transverse bulkheads and bulkhead stools.

9.3.2 In way of vertically corrugated transverse bulkheads supported by stools, additional girders are to be arranged extending at least to the first plate floor adjacent to the bulkhead each side and spaced not more than 3,8 m apart, see *Pt 4, Ch 9, 7.4 Bulkheads supported by stools 7.4.5*.

9.3.3 The centre girder is to have a depth of not less than that given by:

$$d_{DB} = 28B + 205\sqrt{T} \quad \text{mm}$$

The height of the double bottom is also to satisfy the requirements given in *Pt 4, Ch 9, 1.3 Class notation and applicable Rules for CSR Double Hull Oil Tankers*.

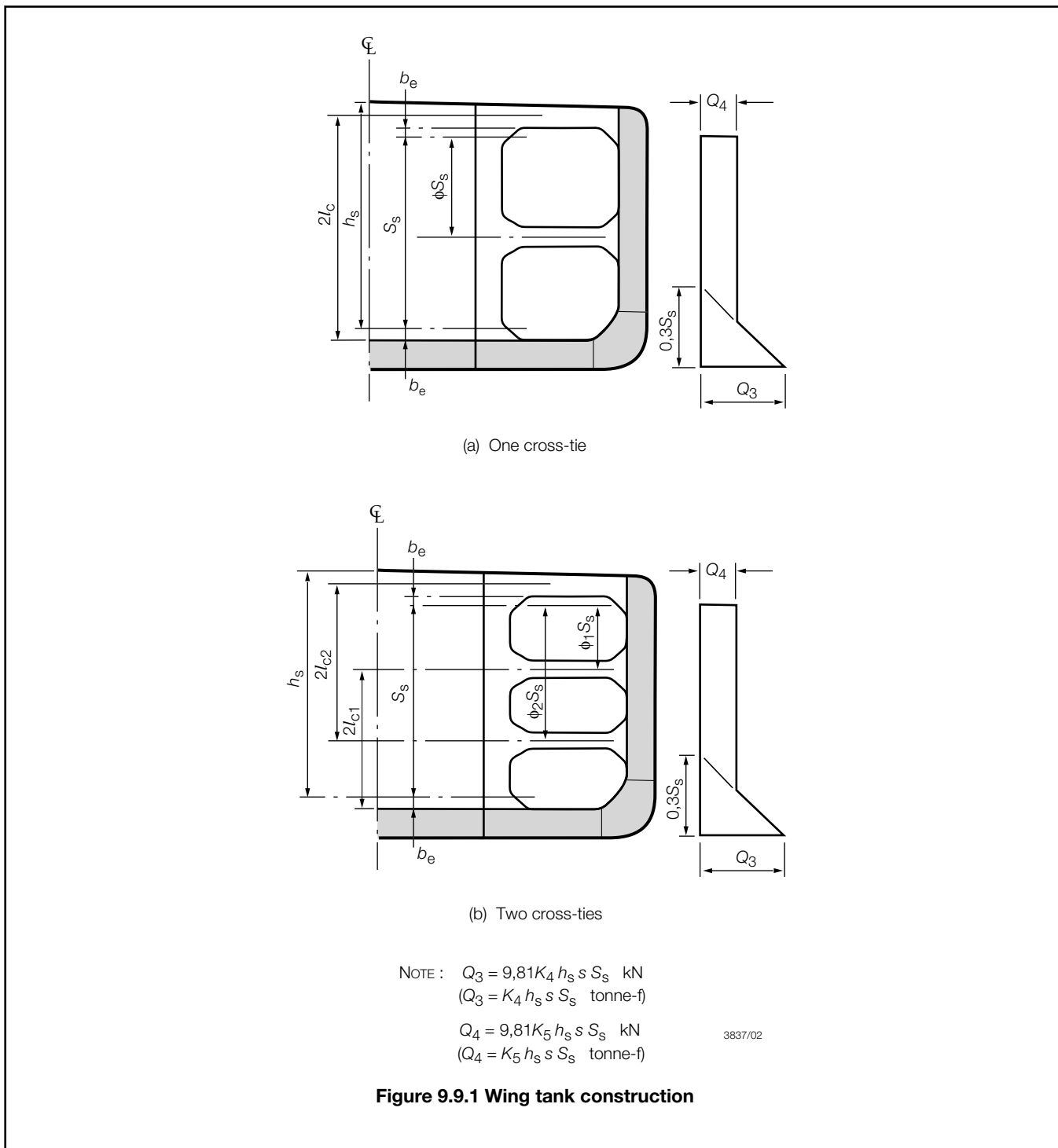

9.3.4 Thickness of floors and girders is to be confirmed by means of a direct calculation. Due account is to be taken of access and other openings. The minimum thickness however, is to be not less than that given by:

(a) Centre girder or duct keel:

$$t = (0,008d_{DB} + 1,0) \sqrt{k} \text{ mm}$$

(b) Floors and side girders:

$$t = (0,007d_{DB} + 1,0) \sqrt{k} \text{ mm but need not exceed } 12,0 \sqrt{k} \text{ mm.}$$

9.3.5 The scantlings of plating and stiffeners of longitudinal girders are not to be less than necessary to comply with the buckling requirements of Pt 3, Ch 4, 7 Hull buckling strength.

9.3.6 Floors and girders forming the boundaries of tanks are also to satisfy the requirements of tank bulkheads given in *Pt 4, Ch 1, 9 Bulkheads*.

9.3.7 Provision is to be made for the free passage of air and water from all parts of the tanks to the air pipes and suction, account being taken of the pumping rates required. Adequate access is also to be provided to all parts of the double bottom. The edges of all openings are to be smooth. The size of the opening should not, in general, exceed 50 per cent of the double bottom depth, unless edge reinforcement is provided. In way of ends of floors and fore and aft girders at transverse bulkheads, the number and size of openings are to be kept to a minimum, and the openings are to be circular or elliptical. Edge stiffening may be required in these positions.

9.3.8 For ships intended to load or unload while aground, see *Pt 3, Ch 9, 7 Bottom strengthening for loading and unloading aground*.

9.3.9 The structure of girders and duct keels is to be sufficient to withstand the forces imposed by dry-docking the ship, see also *Pt 4, Ch 9, 10.10 Double bottom girders in way of docking supports*.

9.4 Vertical webs and horizontal girders in wing ballast tanks and hopper spaces

9.4.1 The width of the double skin side structure is to comply with the requirements given in *Pt 4, Ch 9, 1.3 Class notation and applicable Rules for CSR Double Hull Oil Tankers*.

9.4.2 Vertical webs are to be arranged in line with the floors in the double bottom to ensure continuity of transverse strength.

9.4.3 A horizontal girder is to be arranged at the top of the hopper space and is to be located close to the knuckle between the hopper and inner hull. Where additional longitudinal girders are provided to satisfy access requirements in accordance with *Pt 4, Ch 9, 13.2 Access to spaces in the cargo area 13.2.8*, these are to be arranged in line with horizontal girders on the transverse bulkhead and wing tank cross-ties where these are fitted.

9.4.4 The scantlings of vertical webs and horizontal girders are to be determined by means of direct calculations and due account is to be taken of openings in the structure, see also the buckling requirements in *Pt 3, Ch 4, 7 Hull buckling strength for horizontal girders*.

9.4.5 Access openings are to be kept clear of other small openings and are to have smooth edges. Edge stiffening is also to be arranged in regions of high shear stress.

9.5 Deck transverses and girders

9.5.1 Deck transverses are to be arranged in line with the vertical webs at the side and vertical transverses at longitudinal bulkheads, where fitted, to ensure continuity of transverse structure.

9.5.2 Deck girders are to be supported at transverse bulkheads by vertical webs or equivalent.

9.5.3 The scantlings of deck transverses and girders are to be determined by means of direct calculations or, alternatively, in accordance with the requirements of *Pt 4, Ch 10, 2.8 Deck transverses* and *Pt 4, Ch 10, 2.9 Deck girders*.

9.6 Cross-ties

9.6.1 Cross-ties, where fitted, may be of plate or sectional material and are to have an area and least moment of inertia to satisfy the following:

$$A_c \geq \frac{0,765l_c h_c s k}{\left(1 - \frac{0,45S_c}{r\sqrt{k}}\right)} \text{ cm}^2$$

where

$$r = \sqrt{\frac{I_c}{A_c}} \text{ cm.}$$

(As a first approximation the area and inertia of the cross-tie may be calculated in accordance with *Pt 4, Ch 10, 2.10 Cross-ties 2.10.1*.)

9.6.2 The scantlings of the webs and flanges of cross-ties are also to be confirmed by means of direct calculation.

9.6.3 Design of end connections is to be such that the area of the welding, including vertical brackets, where fitted, is to be not less than the minimum cross-sectional area of the cross-tie derived from Pt 4, Ch 9, 9.6 Cross-ties 9.6.1. To achieve this, full penetration welding may be required and thickness of brackets may require further consideration. Attention is to be given to the full continuity of area of the backing structure on the vertical webs and within the wing ballast tank. Particular attention is also to be paid to the welding at the toes of all vertical end brackets on the cross-tie.

9.7 Primary members supporting oiltight bulkheads

9.7.1 The scantlings of primary members supporting oiltight bulkheads are, in general, to be determined by means of direct calculation, see also Pt 4, Ch 9, 9.7 Primary members supporting oiltight bulkheads 9.7.4 and Pt 4, Ch 9, 9.7 Primary members supporting oiltight bulkheads 9.7.5.

9.7.2 Alternatively, the scantlings of vertical webs and horizontal girders on transverse bulkheads are to be determined in accordance with the requirements of Pt 4, Ch 10, 4 Primary members supporting oiltight bulkheads

9.7.3 Where longitudinal oiltight bulkheads are fitted, vertical webs are to be arranged in line with the deck transverses and the double bottom floors. Particular attention is to be paid to the alignment of the bulkhead web end brackets with the double bottom floors.

9.7.4 The section modulus of vertical webs on longitudinal bulkheads in ships with one or two longitudinal bulkheads is to be not less than:

$$Z = K_3 s h_s S_s^2 k \text{ cm}^3$$

where K_3 is given in Table 9.9.1 Vertical web on longitudinal bulkhead coefficient.

Table 9.9.1 Vertical web on longitudinal bulkhead coefficient

Number of cross-ties	K_3	K_4	K_5	Range of application
1	2,16	0,455-0,316 ϕ	0,103	0,5 $\leq\phi\leq$ 0,7
2	1,88	0,441-0,267 ϕ_1	0,498 ϕ_2 -0,249	0,4 $\leq\phi_1\leq$ 0,5 0,65 $\leq\phi_2\leq$ 0,8

9.7.5 In ships with two longitudinal bulkheads, the net sectional area of the web at any section is not to be less than:

$$A = 0,12Q_x k \text{ cm}^2$$

$$\left(A = \frac{Q_x k}{0,85} \text{ cm}^2 \right)$$

where Q_x is calculated from shear force diagrams constructed as shown in Figure 9.9.1 Wing tank construction. For this purpose the values of K_4 and K_5 and the range of application are given in Table 9.9.1 Vertical web on longitudinal bulkhead coefficient.

9.7.6 The moment of inertia of vertical webs on longitudinal bulkheads is to be not less than:

$$I = \frac{7,5}{k} S_s Z \text{ cm}^4$$

9.7.7 Where horizontal girders and vertical webs on transverse bulkheads do not form part of a ring structure, they are to be arranged with substantial end brackets forming a buttress extending to the adjacent vertical web or transverse. The shear and combined stresses in the buttress arrangements are to be examined.

9.7.8 Where the cross-ties are omitted from the transverse ring in the wing or centre tanks adjacent to the transverse bulkhead, the design of the horizontal girder, end buttress and vertical webs is to take account of the loads imposed and the deflection of the structure.

9.7.9 Where, in ships exceeding 150 m in length, the longitudinal bulkhead is corrugated, the transverses are generally to be symmetrical on both sides of the bulkhead, and the scantlings may require to be increased to limit deflection.

9.8 Primary members supporting non-oiltight bulkheads

9.8.1 These requirements are applicable to primary members supporting non-oiltight transverse bulkheads. Where non-oiltight longitudinal bulkheads are proposed, the requirements for primary members will be individually considered.

9.8.2 Direct calculation procedures will generally be required where non-oiltight bulkhead primary members will interact with, or tend to support, the primary bottom, longitudinal bulkhead or side structure, and in other cases where warranted by structural design features. In general the section modulus of horizontal girders is to be not less than:

$$Z = 145kb l_e^2 \frac{l_b}{L} \text{ cm}^3$$

9.8.3 When determining the width of plating supported and the effective breadth for calculating the section modulus, no deduction is to be made on account of perforations.

■ Section 10 Construction details and minimum thickness

10.1 Symbols

10.1.1 The symbols used in this Section are defined as follows:

For the primary member:

d_w = depth of member web, in mm

s_t = spacing of tripping or docking brackets on the web of the member, in metres

t_w = thickness of member web, in mm

S_w = spacing of members, in metres

For the primary member web stiffener:

d = depth of web plate panel, in mm

l_s = span of stiffeners between effective support points, in metres

s = spacing of stiffeners on the web, in mm

A_s = cross-sectional area of the web stiffener and associated web plating, in cm²

I_s = moment of inertia of the web stiffener and associated web plating, in cm⁴

For the primary member end bracket, see *Figure 9.10.2 Primary member end brackets*:

d_b = arm length, in metres

l_b = effective length of the free edge, in metres

t_b = thickness of the end bracket plating, in mm

A_b = cross-sectional area of the end bracket edge stiffeners and associated plating, in cm²

I_b = moment of inertia of the end bracket edge stiffeners and associated plating, in cm⁴

Other symbols are defined in *Pt 4, Ch 9, 1.5 General definitions and symbols*.

10.2 Compartment minimum thickness

10.2.1 Within the cargo tank region, including wing ballast tanks and cofferdams at the ends of or between cargo tanks, the thickness of primary member webs and face plates, hull envelope and bulkhead plating is to be not less than:

$$t = 2,15L^{0,3} \text{ mm, or}$$

$$t = 7,5 \text{ mm}$$

whichever is the greater.

10.2.2 The minimum thickness of secondary members is to be determined as above, but need not exceed 11,0 mm.

10.2.3 In pump-rooms the minima apply to shell, deck, longitudinal bulkhead and associated longitudinals. For other items solely within the pump-room, including transverse bulkheads separating the adjacent machinery spaces from the pump-room, the minima may be reduced by 1,0 mm, subject to a lower limit of 7,5 mm.

10.2.4 Within the fore peak tank, minimum thicknesses are to be in accordance with *Pt 4, Ch 9, 10.2 Compartment minimum thickness 10.2.1* and *Pt 4, Ch 9, 10.2 Compartment minimum thickness 10.2.2* reduced by 1,0 mm but are to be not less than 7,5 mm.

10.3 Geometric properties and proportions of members

10.3.1 The depth of the web of any primary member is to be not less than 2,5 times the depth of the cut-outs for the passage of secondary members, except where compensation is arranged to provide satisfactory resistance to deflection and shear buckling in the web.

10.3.2 The area of material in the face plate of any primary member structure is not to exceed:

$$0,00667d_w t_w \text{ cm}^2$$

nor is it to be less than:

$$0,00417s_t d_w \text{ cm}^2.$$

10.3.3 The geometric properties of rolled stiffeners and built sections are to be calculated in association with an effective width of attached plating in accordance with *Pt 3, Ch 3, 3 Structural idealisation*.

10.4 Continuity of primary members

10.4.1 Primary members are to be so arranged as to ensure effective continuity of strength throughout the range of tank structure. Abrupt changes of depth or section are to be avoided. Where members abut on both sides of a bulkhead or on other members, arrangements are to be made to ensure that they are in alignment.

10.4.2 The members are to have adequate end fixity, lateral support and web stiffening, and the structure is to be arranged to minimise hard spots or other sources of stress concentration. Openings are to have well rounded corners and smooth edges and are to be located having regard to the stress distribution and buckling strength of the plate panel.

10.5 Primary member web plate stiffening

10.5.1 The webs of primary members are to be supported and stiffened in accordance with the following requirements, which are designated as requirements 'A', 'B', 'C', 'D' and 'E'. The application of these requirements is detailed in *Pt 4, Ch 9, 10.7 Application of stiffening requirements*, and the corresponding locations indicated in *Figure 9.10.1 Key to application requirements*. Where webs are slotted for the passage of secondary members, the web stiffeners are to be arranged to provide adequate support for the loads transmitted, see *Pt 3, Ch 10, 5.2 Arrangements at intersections of continuous secondary and primary members*. Where direct calculations are carried out in accordance with *Pt 4, Ch 9, 1.1 General 1.1.8* and *Pt 4, Ch 9, 14 Direct calculations*, other stiffening arrangements will be accepted subject to compliance with the maximum permissible stress and plate panel buckling criteria given in the *ShipRight SDA Procedure, Guidance Notes on Direct Calculations: Primary Structure of Tankers*.

10.5.2 Where higher tensile steel is used for the primary members, the maximum spacing of stiffeners given in this Section is to be multiplied by \sqrt{k} .

10.5.3 In addition to these stiffeners, tripping brackets as required by *Pt 4, Ch 9, 10.11 Lateral stability of primary members* are also to be fitted.

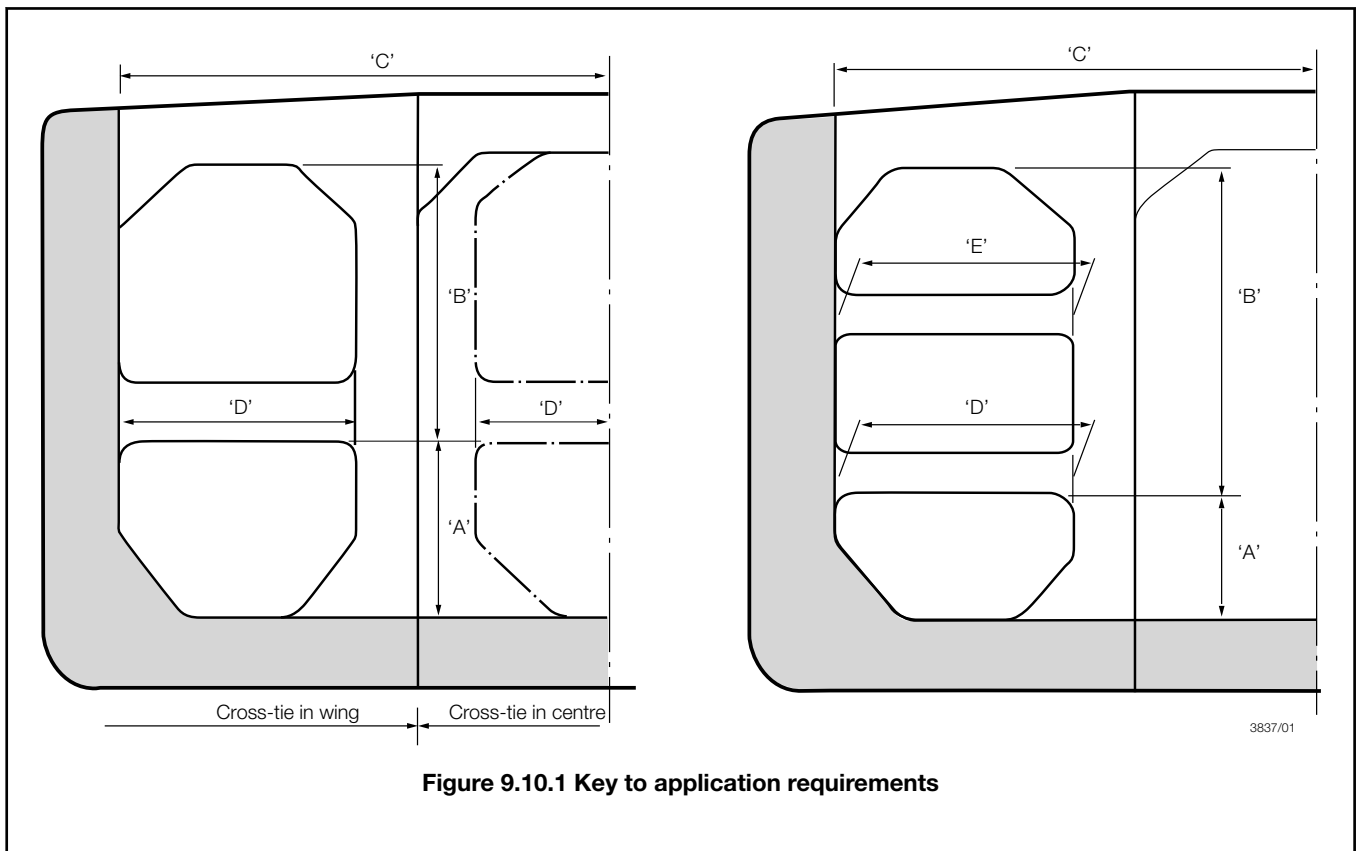

Figure 9.10.1 Key to application requirements

10.5.4 For requirement 'A' stiffening:

- (a) The thickness, t_w of the web is to be not less than $\frac{s}{80}$
- (b) Stiffening is generally to be fitted normal to the face plate of the member, but the stiffeners parallel to the face plate will be required when the web depth, d_w , exceeds a value, d_{max} which is to be taken as:

$$\text{for } s \leq 55t_w \quad d_{max} = 3s$$

$$\text{for } s > 55t_w \quad d_{max} = \frac{45st_w}{s - 40t_w}$$

- (c) Where stiffening parallel to the face plate is required, the distance from the face plate of the member to the nearest stiffener is not to exceed $65t_w$. Further stiffeners are to be fitted at similar spacing so that the distance between the last stiffener and the shell or bulkhead plating does not exceed d_{max} . In way of end brackets to transverse bulkhead primary structure, stiffeners are to be fitted normal to the face plate of the member so that web plate panel dimensions parallel to the face plate do not exceed $80t_w$.

10.5.5 For requirement 'B' stiffening:

- (a) The thickness, t_w of the web is to be not less than $\frac{s}{85}$
- (b) Stiffening is generally to be fitted normal to the face plate of the member, but stiffeners parallel to the face plate will be required when the web depth, d_w , exceeds a value d_{max} , which is to be taken as:

$$\text{for } s \leq 70t_w \quad d_{max} = 3s$$

$$\text{for } s > 70t_w \quad d_{max} = \frac{48st_w}{s - 54t_w}$$

- (c) Where stiffening parallel to the face plate is required, the distance from the face plate of the member to the nearest stiffener is not to exceed $80t_w$. Further stiffeners are to be fitted at similar spacing so that the distance between the last stiffener and the shell or bulkhead plating does not exceed d_{max} .

10.5.6 For requirement 'C' stiffening:

- (a) Stiffening is generally to be fitted normal to the face plate of the member in line with alternate secondary members, but stiffeners parallel to the face plate will be required, when the web depth, d_w exceeds a value, d_{max} which is to be taken as:

$$\text{for } s \leq 76t_w \quad d_{max} = 3s$$

$$\text{for } s > 76t_w \quad d_{max} = \frac{48st_w}{s - 60t_w}$$

- (b) Where stiffening parallel to the face plate is required, the distance from the face plate of the member to the nearest stiffener is not to exceed $90t_w$. Further stiffeners are to be fitted at similar spacing so that the distance between the last stiffener and the deck plating does not exceed d_{max} .

10.5.7 For requirement 'D' stiffening:

- (a) Stiffening parallel to the face plate will be required such that the distance between the stiffener and face plate, or between two stiffeners, does not exceed:

$$80t_w \text{ where } L \leq 90 \text{ m}$$

$$55t_w \text{ where } L \geq 190 \text{ m}$$

with intermediate values by interpolation.

- (b) Brackets are to be fitted to support the face plates and stiffeners.

10.5.8 For requirement 'E' stiffening:

- (a) Stiffening parallel to the face plate will be required such that the distance between the stiffener and face plate, or between two stiffeners, does not exceed:

$$85t_w \text{ where } L \leq 90 \text{ m}$$

$$60t_w \text{ where } L \geq 190 \text{ m}$$

with intermediate values by interpolation.

- (b) Brackets are to be fitted to support the face plates and stiffeners.

10.6 Inertia and dimensions of stiffeners

10.6.1 The moment of inertia is to be not less than:

- (a) For stiffeners normal to the primary member face plate:

$$I_s = pst_w^3 \times 10^{-4} \text{ cm}^4$$

Where t_w need not be greater than the values in *Table 9.10.1 Maximum web thickness for stiffener inertia* and p is to be obtained from *Table 9.10.2 Coefficients for stiffener inertia*.

- (b) For stiffeners parallel to the primary member face plate:

On transverses, webs and stringers

$$I_s = 2l_s^2 A_s \text{ cm}^4$$

On longitudinal deck, side and double bottom girders, see also *Pt 3, Ch 4, 7 Hull buckling strength*

$$I_s = 2,85l_s^2 A_s \text{ cm}^4$$

Table 9.10.1 Maximum web thickness for stiffener inertia

Requirement	Web thickness t_w , in mm
'A'	$\frac{s}{55}$
'B' and 'C'	$\frac{s}{70}$

`D'	$\frac{s}{80}$ where $L \leq 90\text{ m}$ $\frac{s}{55}$ where $L \leq 190\text{ m}$ Intermediate values by interpolation.
`E'	$\frac{s}{85}$ where $L \leq 90\text{ m}$ $\frac{s}{60}$ where $L \leq 190\text{ m}$ Intermediate values by interpolation.

10.6.2 Where stiffeners are fitted in both directions, the inertia of the stiffeners parallel to the face plate of the member is to be not less than that of the stiffeners fitted normally.

10.6.3 The depth of web stiffeners is to be not less than 75 mm.

10.6.4 Where flat bar stiffeners are used, the ratio of depth to thickness is not to exceed $18\sqrt{k}$.

10.7 Application of stiffening requirements

10.7.1 The requirements as detailed in *Pt 4, Ch 9, 10.5 Primary member web plate stiffening* and *Pt 4, Ch 9, 10.6 Inertia and dimensions of stiffeners* are to be applied in the following locations, see also *Figure 9.10.1 Key to application requirements*.

(a) For transverses at longitudinal bulkhead:

Requirement `A' stiffening is to extend at least as far as the lower surface of the lower cross-tie. Elsewhere, requirement `B' stiffening is to be fitted.

(b) For deck transverses:

Requirement `C' stiffening is to be fitted.

(c) For stringers and horizontal girders on bulkheads:

Requirement `A' stiffening is to extend for a distance from each end of 20 per cent of the span of the stringer or girder, but at least beyond the toes of the end brackets. Elsewhere, requirement `B' stiffening is to be fitted.

(d) For cross-ties:

Cross-ties are to be suitably stiffened to prevent buckling and twisting. Requirement `D' stiffening is to be fitted to the lower or to a single cross-tie. Requirement `E' stiffening is to be fitted to the upper cross-ties where two cross-ties are arranged.

(e) For shell stringers and vertical webs in fore peak:

Requirement `A' stiffening is to extend the full length of the member.

10.7.2 The application of stiffening requirements to transverse structures where no cross-ties are fitted and within double hull structures are to be based on the results of direct calculation and will be specially considered.

10.8 Stiffening of continuous longitudinal girders

10.8.1 The webs of continuous longitudinal deck and double bottom girders are to be stiffened longitudinally. Particular attention is to be given to the stiffening of docking girders, see also the buckling requirements in *Pt 3, Ch 4, 7 Hull buckling strength*.

Table 9.10.2 Coefficients for stiffener inertia

Aspect ratio of plate panel, $\frac{s}{d}$	1,0 or more	0,9	0,8	0,7	0,6	0,5	0,4	0,3 or less
p	1,5	2,1	2,9	4,2	6,1	9,2	14,6	30,0

Note 1. Intermediate values by interpolation.

Note 2. The depth of panel, d , used in calculating aspect ratio may be measured from the face of the secondary member to which the primary member web stiffener is attached.

10.8.2 The stiffeners on deck girders are to be spaced not more than $55t_w$ mm apart except in way of vertical webs and end brackets, where the spacing is not to exceed $45t_w$ mm. Alternatively, a combination of parallel stiffeners at $55t_w$ mm spacing and normal stiffeners at $45t_w$ mm spacing may be adopted. Particular attention is to be given to the stiffening of the docking girder.

10.8.3 The application of stiffening requirements to girders within double hull structures is to be based on the results of direct calculation, see also *Pt 4, Ch 9, 10.10 Double bottom girders in way of docking supports 10.10.1*.

10.8.4 The moment of inertia of the stiffeners is to comply with *Pt 4, Ch 9, 10.6 Inertia and dimensions of stiffeners*.

10.9 Stiffening of vertical webs on transverse bulkheads

10.9.1 Vertical webs are to be fitted with stiffeners parallel to the face plate of the web and spaced not more than $60t_w$ mm apart. Stiffeners normal to the face plate are to be fitted when a vertical web supports horizontal stiffeners on transverse bulkheads. The length of stiffener is to be sufficient to distribute the load transmitted, and the connection between web stiffener and bulkhead stiffener is to comply with the relevant requirements of *Pt 3, Ch 10, 5.2 Arrangements at intersections of continuous secondary and primary members*.

10.9.2 The moment of inertia of the stiffeners is to comply with *Pt 4, Ch 9, 10.6 Inertia and dimensions of stiffeners*.

10.10 Double bottom girders in way of docking supports

10.10.1 Additional vertical stiffeners may be required on the bottom panels of the girder to resist docking pressures.

10.11 Lateral stability of primary members

10.11.1 Tripping brackets are generally to be fitted close to the toes of end brackets, in way of cross-ties and elsewhere, so that the spacing between brackets does not exceed the lesser of 4,5 m or 15 times the width of the face plate (20 times in the case of deck transverses). Arrangements in way of the intersections of primary members are to be such as to prevent tripping. A closer spacing of brackets may be required to be adopted with asymmetrical face plates.

10.11.2 To maintain continuity of strength, substantial horizontal and vertical brackets are to be fitted to transverses or stringers at ends of cross-ties. Horizontal brackets are to be aligned with the cross-tie face plates, and vertical end brackets are to be aligned with the cross-tie web.

10.11.3 Wide face plates may require additional support between brackets.

10.11.4 In the fore peak tank, if the angle between the normal to the shell plating and the vertical webs exceeds 20° , tripping brackets are to be fitted at the toes of end brackets and elsewhere, such that their spacing does not exceed 3 m.

10.12 Openings in web plating

10.12.1 Where openings are cut in the webs of primary supporting members, the greatest dimension of the opening is not to exceed 20 per cent of the web depth. The openings are to be kept equidistant from the corners of notches for frames and stiffeners. In the case of webs supporting single skin structures the openings are to be located so that the edges are not less than 40 per cent of web depth from the face plate. Openings are to be suitably framed where required.

10.12.2 In way of cross-ties and their end connections lightening holes are not to be cut in horizontal girders on the ship's side and longitudinal bulkheads, in symmetrical webs nor in vertical webs on longitudinal bulkheads and wing ballast tanks.

10.12.3 Holes cut in primary longitudinal members within $0,1D$ of the deck and bottom are, in general, to be reinforced as required by *Pt 4, Ch 9, 4.10 Deck openings*. Access holes may be cut in deep transverses and girders with suitable compensation to provide satisfactory resistance to deflection and shear buckling in the web.

10.12.4 All holes are to have smooth edges and are to be kept well clear of notches and the toes of brackets.

10.12.5 Small air and drain holes cut in primary members are to be kept clear of the toes of brackets and are to be well rounded with smooth edges. Where holes are cut in primary longitudinal members in areas of high stress, or where primary members are of higher tensile steel, they are to be elliptical, or equivalent, to minimise stress concentration.

10.12.6 Where holes are cut for heating coils, the lower edge of the hole is to be not less than 100 mm from the inner bottom. Where large notches are cut in the transverses for the passage of longitudinal framing, adjacent to openings for heating coils, the longitudinal notches are to be collared. Examination of the buckling strength of the web plate panel between notches for longitudinals may be required.

10.13 Brackets connecting primary members

10.13.1 The arm length of brackets connecting primary supporting members should, in general, be not less than the depth of the member web, nor exceed 1,5 times the web depth. The two arms should be of approximately equal lengths.

10.13.2 In a ring system where the end bracket is integral with the webs of the members, and the face plate is carried continuously along the edges of the members and the bracket, the full area of the largest face plate is to be maintained to the mid-point of the bracket and gradually tapered to the smaller face plates. Butts in face plates are to be kept well clear of the toes of brackets. Where a wide face plate abuts on a narrower one, the taper is generally not to exceed 1 in 4. Where a thick face plate abuts against a thinner one, if the difference in thickness exceeds 3 mm, the taper on thickness is not to exceed 1 in 3.

10.13.3 The thickness of separate end brackets is generally to be not less than that of the thicker of the primary member webs being connected, but may be required to be increased locally at the toes. The bracket is to extend to adjacent tripping brackets, stiffeners or other support points. Bracket toes are to be well radiused. Where the bracket is attached to a corrugated bulkhead, suitable arrangements are to be made to dissipate the load at the bracket toe. Details of the welding to be used is way of toes separate brackets are to be submitted, see also Pt 3, Ch 10, 5.1 Continuity and alignment 5.1.7.

10.13.4 Brackets are to be fitted with suitable face plates and stiffeners. The maximum distance from the face plate to the first parallel stiffener is to be $30t_b$. Subsequent stiffeners lying parallel to the face may be spaced not more than $45t_b$ apart. The maximum arm length for an unstiffened triangular panel is $100t_b$, see Figure 9.10.2 Primary member end brackets. The depth of stiffeners is to be not less than 75 mm, and their moment of inertia is to comply with 10.6.

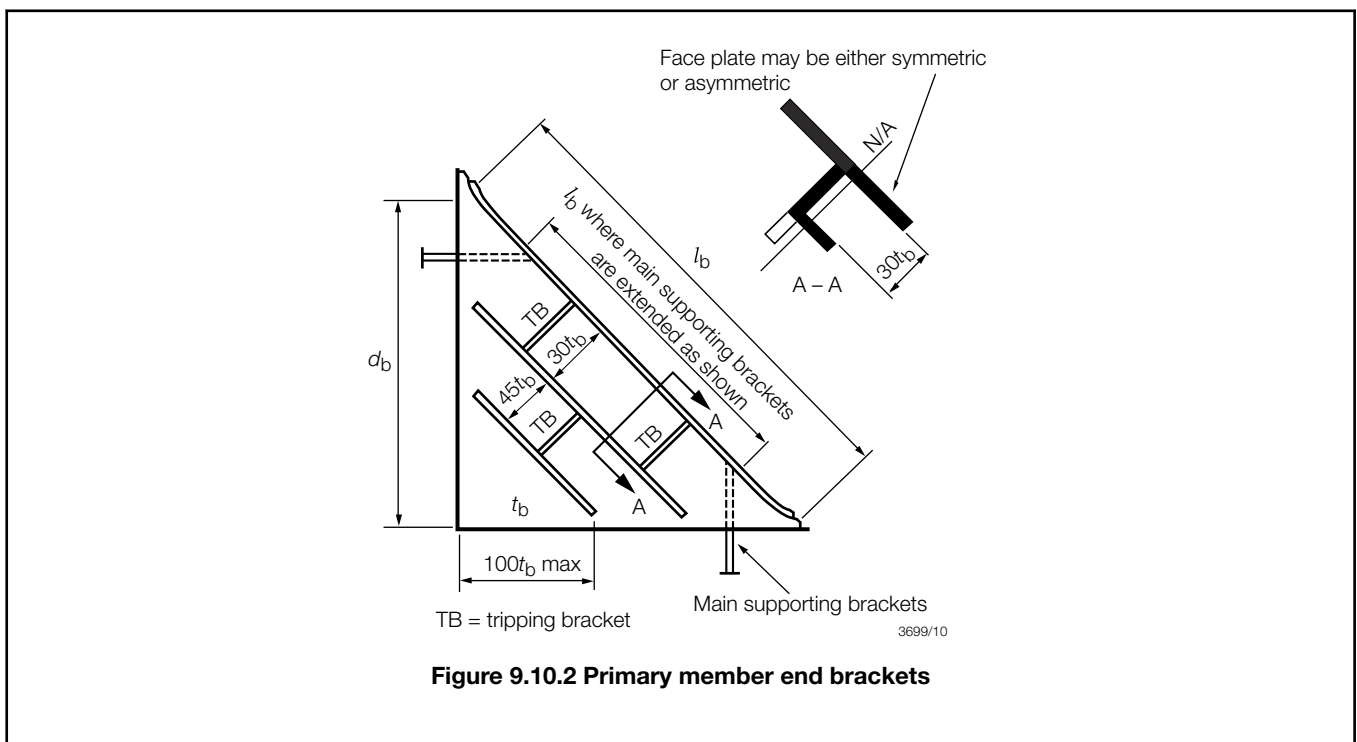

Figure 9.10.2 Primary member end brackets

10.13.5 The area of discontinuous face plates is generally to be about 80 per cent of the area of the face plates of the adjacent members. However, where the stiffener adjacent to the face plate is of increased size, consideration will be given to the face area required. In addition, the following expression is to be satisfied:

$$\sqrt{\frac{I_b}{A_b}} \geq 2 l_b$$

10.13.6 The ends of discontinuous face plates are to be well tapered. The taper may be 1 in 3, but where the width of the face plate exceeds 500 mm, a taper not less than 1 in 4 is generally to be adopted. Stiffeners adjacent to the face plate should be tapered 1 in 2, and other stiffeners may be cut at 45°.

10.13.7 Face plates and web stiffeners are to be suitably supported against tripping, see Figure 9.10.2 Primary member end brackets.

10.13.8 In the case of very large brackets with heavy face plates, it is recommended that the effective span, l_b , be reduced by extending the primary member main supporting brackets to provide lateral stability to the face plate, see Figure 9.10.2 Primary member end brackets.

10.14 Arrangements at intersections of continuous secondary and primary members

10.14.1 For details and connections of collars, see *Pt 3, Ch 10, 5.2 Arrangements at intersections of continuous secondary and primary members*.

■ Section 11
Ships for alternate carriage of oil cargo and dry bulk cargo**11.1 Application**

11.1.1 The requirements of this Section apply to ships intended to carry oil in bulk with a flash point not exceeding 60° (closed-cup test) or dry bulk cargo alternatively.

11.1.2 In addition to this Chapter the requirements of *Pt 4, Ch 7 Bulk Carriers* and *Pt 4, Ch 11 Ore Carriers* are also to be complied with as applicable. Particular attention is drawn to the minimum thickness requirements of *Pt 4, Ch 9, 10 Construction details and minimum thickness*.

11.2 Class notations

11.2.1 Ships complying with the requirement of this section will be eligible for one of the following class notations, as applicable.

- (a) **100A1 Oil or Bulk Carrier, ESP**
- (b) **100A1 Oil or Bulk Carrier strengthened for heavy cargoes, holds ... may be empty, ESP**
- (c) **100A1 Oil or Bulk Carrier strengthened for heavy cargoes, any hold may be empty, ESP**
- (d) **100A1 Ore or Oil Carrier, ESP.**

11.2.2 The notation **ESP** serves to identify the ship as being subject to an Enhanced Survey Programme as detailed in *Pt 1, Ch 3, 3 Intermediate Surveys - Hull and machinery requirements* and *Pt 1, Ch 3, 6 Special Survey - Bulk carriers - Hull requirements* and *Pt 1, Ch 3, 7 Special Survey - Oil tankers (including ore/oil ships and ore/bulk/oil ships) - Hull requirements*, see also *Pt 1, Ch 2, 2.3 Class notations (hull) 2.3.12*.

11.2.3 The above notations assume that dry cargoes and oil cargoes will not be carried simultaneously. However, oil may be retained in slop tanks when the ship is carrying dry cargo, provided that these tanks comply with the requirements of the Rules. Gas freeing, inerting, and isolating by approved arrangements of the remaining tanks and holds before loading ore or other dry cargoes is the responsibility of the Owner and is to be in accordance with National and Port Authority requirements.

11.2.4 The Regulations for classification and the assignment of class notations are given in *Pt 1, Ch 2 Classification Regulations* to which reference should be made.

11.3 Structural configuration and ship arrangement

11.3.1 The requirements contained in this Section apply to the following ship types:

- (a) Oil or bulk carrier with a basic structural configuration having a single deck hull and which includes, a double skin side structure, double bottom, hopper side tanks and topside tanks fitted below the upper deck. A typical cross-section is indicated in *Figure 9.11.1 Structural configuration*. However, consideration will be given to other arrangements on the basis of the requirements of this Section. The requirements of *Pt 4, Ch 7 Bulk Carriers* are to be applied.
- (b) Ore or oil carrier with a basic structural configuration having a single deck hull and which includes, a double skin side structure, two longitudinal bulkheads, and a double bottom throughout the centre hold and wing tanks. A typical cross-section is indicated in *Figure 9.11.1 Structural configuration*. The requirements of *Pt 4, Ch 11 Ore Carriers* are to be applied.

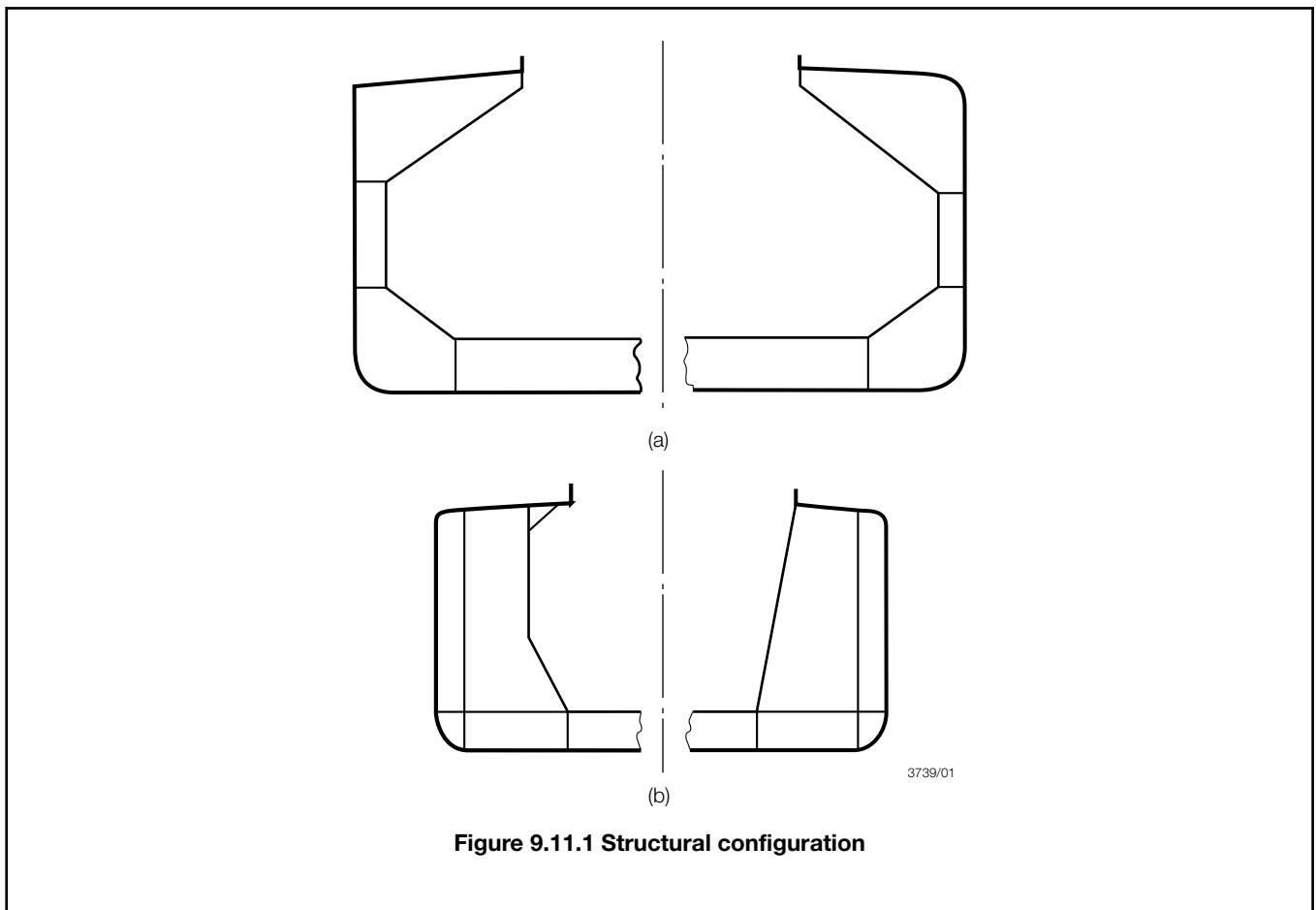

11.3.2 Where oil residues are to be retained on board, slop tanks of sufficient capacity to meet MARPOL requirements are to be provided and are to be separated from adjacent spaces by cofferdams which are to be capable of being flooded, except where the adjacent space is used as a pump-room, ballast tank, or a fuel oil bunker tank, *see also Pt 4, Ch 9, 1.2 Application and ship arrangement 1.2.2, Pt 5, Ch 15, 1.9 Non-sparking fans for hazardous areas and SOLAS Reg. II-2 Part D - Escape.*

11.3.3 Arrangements are to be provided for the mechanical ventilation of cargo spaces and any enclosed spaces adjacent to cargo spaces, *see Pt 5, Ch 15, 3 Cargo handling system.* Similar arrangements are to be provided for cargo oil ducts which are used as pipe tunnels when the ship is carrying dry cargo, *see also Pt 4, Ch 9, 11.3 Structural configuration and ship arrangement 11.3.5.*

11.3.4 Openings which may be used for cargo operations, for example in the bottom of topside tanks, are not permitted in bulkheads and decks separating oil cargo spaces from other spaces not designed and equipped for the carriage of oil cargoes unless such openings are equipped with alternative approved means to ensure equivalent integrity.

11.3.5 For the requirements of ducts for cargo oil lines below decks on ore or oil carriers, *see Pt 5, Ch 15, 3.3 Cargo piping system.*

11.3.6 For the requirements for access arrangements to pipe tunnels and spaces in the cargo area, *see Pt 4, Ch 9, 13 Access arrangements and closing appliances.*

11.4 Bulkheads in way of dry/oil cargo holds

11.4.1 In way of cargo oil holds, the scantlings of the cargo space boundaries are to comply with *Pt 4, Ch 9, 11.4 Bulkheads in way of dry/oil cargo holds 11.4.2 and Pt 4, Ch 9, 11.4 Bulkheads in way of dry/oil cargo holds 11.4.6.*

11.4.2 The scantlings of vertically corrugated and double plate transverse bulkheads supported by stools are to be determined in accordance with the requirements of *Pt 4, Ch 9, 7.4 Bulkheads supported by stools 7.4.1, Pt 4, Ch 9, 7.4 Bulkheads supported by stools 7.4.2 and Pt 4, Ch 7, 10.2 Bulkheads supported by stools.* In general, the bulkheads are to have stiffening or corrugations arranged vertically, supported by top and bottom end stools. Alternative arrangements will, however, be considered.

11.4.3 The longitudinal bulkheads including bulkhead forming inner hull, and the sloped bulkheads of the topside and double bottom tanks are to comply with *Pt 4, Ch 9, 6 Inner hull, inner bottom and longitudinal oiltight bulkheads*. However, in way of cargo holds b_1 is to be taken as the horizontal distance from the plate or longitudinal under consideration to the vertical projection of the hatch side furthest away from the bulkhead. For longitudinal framing the determination of the span point may be in accordance with *Pt 3, Ch 3, 3 Structural idealisation*. The scantlings of the sloped bulkhead of the double bottom hopper tanks in way of the dry cargo holds are to be not less than the requirements of *Pt 4, Ch 7, 9 Hopper side tank structure*.

11.4.4 The arrangement of stools and adjacent structure common with dry cargo holds is to be designed to avoid pockets in which gas could collect.

11.4.5 Where the form of construction used for transverse bulkheads in wing tanks is different from that used in centre holds, arrangements are to be made to ensure continuity of transverse strength through the longitudinal bulkhead.

11.4.6 Where partial filling of centre holds with liquid is contemplated, the scantlings and structural arrangements of the boundary bulkheads are to be capable of withstanding the loads imposed by the movement of liquid in the holds. The magnitude of the predicted loadings, together with the scantling calculations, may require to be submitted.

11.5 Bulkheads in wing tanks of ore or oil carriers

11.5.1 Oiltight bulkheads in wing tanks of ore or oil carriers, see *Pt 4, Ch 9, 11.3 Structural configuration and ship arrangement 11.3.1* are to comply with the requirements for transverse oiltight bulkhead plating, stiffening and primary structure given in *Pt 4, Ch 9, 7 Transverse oiltight bulkheads* and *Pt 4, Ch 9, 9 Primary members supporting longitudinal framing*.

11.5.2 Non-oiltight bulkheads in wing tanks are to comply with the requirements given in *Pt 4, Ch 9, 8 Non-oiltight bulkheads* and *Pt 4, Ch 9, 9 Primary members supporting longitudinal framing*. The bulkhead plating is to be suitably reinforced in way of double bottom scarfing arrangements and the ends of centre hold deck transverses. Openings in wing tank bulkheads are to be kept clear of these areas.

11.6 Cofferdam bulkheads

11.6.1 The scantlings of cofferdam bulkheads not forming the boundary of a cargo space are to be as required by *Pt 4, Ch 9, 7 Transverse oiltight bulkheads*.

11.7 Hatchways

11.7.1 The scantlings of the cargo hold hatch coamings are to comply with *Pt 3, Ch 11, 5 Hatch coamings* and the cargo hold hatch covers with *Pt 3, Ch 11, 2 Steel hatch covers* and *Pt 4, Ch 7, 12 Steel hatch covers*.

11.7.2 Where cargo holds are intended to be partly filled the hatch covers may require to be additionally strengthened, see also *Pt 4, Ch 9, 11.4 Bulkheads in way of dry/oil cargo holds 11.4.6*.

11.7.3 Slop tank hatches and cleaning openings are only permitted on open deck. Unless these openings are closed with a watertight bolted plate, the locking arrangements are to be under the control of a responsible officer.

11.8 Hatch coamings

11.8.1 The height and construction of hatch coamings are to comply with *Pt 3, Ch 11, 5 Hatch coamings* and *Pt 4, Ch 7, 13 Hatch coamings*.

■ Section 12

Cargo temperatures

12.1 General

12.1.1 This Section applies to the carriage of heated and low temperature cargoes in vessels having a structural configuration as shown in *Table 9.1.3 Structural arrangement* and *Figure 9.11.1 Structural configuration*.

12.2 Loading and carriage of heated cargoes

12.2.1 Where cargoes are to be loaded or carried at temperatures above 80°C, temperature distribution investigations and thermal stress calculations are to be submitted. These are to be carried out using the highest cargo temperature during any part of the voyage, including loading and unloading.

12.2.2 The calculations are to give the resultant stresses on the hull structure, based on a sea temperature of 0°C and an air temperature of 5°C. Any proposals for reinforcement of the hull structure and/or limitation of the still water bending moment for heated cargo conditions are to be submitted.

12.2.3 Submitted proposals are to take account of non-uniform loading patterns with resultant variations in temperature distribution, where applicable.

12.3 Low temperature cargoes

12.3.1 The hull structural and engineering systems permit cargoes to be loaded down to -10°C. For low temperature operations, see *Pt 8 Rules for Ice and Cold Operations* and the *Provisional Rules for the Winterisation of Ships, July 2015*.

■ Section 13**Access arrangements and closing appliances****13.1 General**

13.1.1 For requirements in respect of coamings and closing of deck openings, see *Pt 3, Ch 11, 7 Tanker access arrangements and closing appliances*.

13.1.2 Openings in cargo oil tanks are not to be located in enclosed spaces.

13.1.3 Ladders and platforms in cargo tanks, pump-rooms and cofferdams are to be securely fastened to the structure, see also *Pt 4, Ch 9, 2.3 Aluminium structure, fittings and paint*.

13.2 Access to spaces in the cargo area

13.2.1 Access to cofferdams, vertical wing and double bottom ballast tanks, cargo tanks and other spaces in the cargo area shall be direct from the open deck and such as to ensure their complete inspection. Access to double bottom tanks in way of cargo oil tanks, where wing ballast tanks are omitted, is to be provided by trunks from the exposed deck led down the bulkhead. Alternative proposals will, however, be considered provided the integrity of the inner bottom is maintained. Access to double bottom spaces may also be through a cargo pump-room, pump-room, deep cofferdam, pipe tunnel or similar compartments, subject to consideration of ventilation aspects.

13.2.2 Where a duct keel or pipe tunnel is fitted, and access is normally required for operational purposes, access is to be provided at each end and at least one other location at approximately mid-length. Access is to be directly from the exposed deck. Where an after access is to be provided from the pump-room to the duct keel, the access manhole from the pump-room to the duct keel is to be provided with an oiltight cover plate. Access is not to be via the engine room. Mechanical ventilation is to be provided and such spaces are to be adequately ventilated prior to entry. A notice-board is to be fitted at each entrance to the pipe tunnel stating that before any attempt is made to enter, the ventilating fan must have been in operation for an adequate period. In addition, the atmosphere in the tunnel is to be sampled by a reliable gas monitor, and where an inert gas system is fitted in cargo tanks, an oxygen monitor is to be provided.

13.2.3 In ships for the alternate carriage of oil cargo and dry bulk cargo where the boundary of a slop tank is part of a cargo pump-room bulkhead, any openings from the cargo pump-room to the double bottom, pipe tunnel or other enclosed space are to be provided with a gastight bolted cover.

13.2.4 Every double bottom space is to be provided with separate access without passing through other neighbouring double bottom spaces.

13.2.5 Where the tanks are of confined or cellular construction, two separate means of access from the weather deck are to be provided, one to be provided at either end of the tank space.

13.2.6 For access through horizontal openings, hatches or manholes, the dimensions are to be sufficient to allow a person wearing a self-contained air-breathing apparatus and protective equipment to ascend or descend any ladder without obstruction

and also to provide a clear opening to facilitate the hoisting of an injured person from the bottom of the space. The minimum clear opening is to be not less than 600 mm x 600 mm.

13.2.7 At least one horizontal access opening of 600 mm x 800 mm clear opening is to be fitted in each horizontal girder in the vertical wing ballast space and weather deck to assist in rescue operations.

13.2.8 For access through vertical openings, or manholes providing passage through the length and breadth of the space, the minimum clear opening is to be not less than 600 mm x 800 mm at a height of not more than 600 mm from the bottom shell plating unless gratings or other footholds are provided.

13.2.9 For oil tankers of less than 5000 tonnes DWT smaller dimensions may be approved by the National Administration concerned in special circumstances, if the ability to traverse such openings or to remove an injured person can be proved to the satisfaction of the Administration.

13.2.10 In double hull construction with the wing ballast tanks having restricted access through the vertical transverse webs, permanent arrangements are to be provided within the tanks to permit access for inspection at all heights in each bay. These arrangements which should comprise fixed platforms or other means are to provide sufficiently close access to carry out Close-Up Surveys as defined in *Pt 1, Ch 3, 7 Special Survey - Oil tankers (including ore/oil ships and ore/bulk/oil ships) - Hull requirements*, using limited portable equipment where appropriate. Details of these arrangements are to be submitted for approval.

13.2.11 On very large tankers it is recommended that consideration be given to providing permanent facilities for staging the interior of cargo tanks situated within the cargo tank region and of large tanks elsewhere. Suitable provisions would be:

- Staging which can be carried on board and utilised in any tank, including power-operated lift or platform systems.
- Enlargement of structural members to form permanent, safe platforms, e.g. bulkhead longitudinals widened to form stringers (in association with manholes through primary members).
- Provision of inspection/rest platforms at intervals down the length of access ladders.
- Provision of manholes in upper deck for access to staging in cargo tanks.

13.2.12 Attention is drawn to *Pt 4, Ch 9, 7.1 General 7.1.7*, concerning provision of manholes in transverse bulkheads.

■ Section 14 Direct calculations

14.1 Application

14.1.1 Direct calculations are to be carried out for the derivation of scantlings where they are required by the preceding Sections of this Chapter or by related provisions included in *Pt 3 Ship Structures (General)*.

14.1.2 Direct calculation methods are also generally to be used where additional calculations are required by the Rules in respect of unusual structural arrangements.

14.2 Procedures

14.2.1 For details of LR's direct calculation procedures, see *Pt 3, Ch 1, 2 Direct calculations*. For requirements concerning use of other calculation procedures, see *Pt 3, Ch 1, 3 Equivalents*.

14.2.2 Details of direct calculation procedures for determining the scantlings of boundary bulkheads for partially filled tanks are given in *ShipRight SDA procedure, Sloshing loads and Scantling Assessment*.

Section

- 1 **General**
- 2 **Primary members supporting longitudinal framing**
- 3 **Primary members supporting transverse side framing**
- 4 **Primary members supporting oiltight bulkheads**
- 5 **Primary members supporting non-oiltight bulkheads**
- 6 **Trunked construction**
- 7 **Construction details and minimum thickness**

■ Section 1 General

1.1 Application

1.1.1 The requirements specified in *Pt 4, Ch 9 Double Hull Oil Tankers* are applicable to small conventional single hull oil tankers where relevant, together with the additional requirements of this Chapter.

1.1.2 For tankers intended to load or unload whilst aground, see *Pt 3, Ch 9, 7 Bottom strengthening for loading and unloading aground*.

1.2 Class notations

1.2.1 Sea-going ships complying with the requirements of *Pt 4, Ch 9 Double Hull Oil Tankers*, where relevant, together with the additional requirements of this Chapter will be eligible to be classed **100A1 Oil Tanker, ESP**.

1.2.2 The Notation **ESP** serves to identify the ships as being subject to an Enhanced Survey Programme as detailed in *Pt 1, Ch 3, 3 Intermediate Surveys - Hull and machinery requirements* and *Pt 1, Ch 3, 7 Special Survey - Oil tankers (including ore/oil ships and ore/bulk/oil ships) - Hull requirements*, see also *Pt 1, Ch 2, 2 Character of classification and class notations*.

■ Section 2 Primary members supporting longitudinal framing

2.1 General

2.1.1 These requirements are applicable to the following structural arrangements for ships with two longitudinal bulkheads:

(a) Centre tank structure:

- (i) Primary supporting centreline girder between oiltight transverse bulkheads, in association with up to five transverses.
- (ii) Bottom transverses spanning between longitudinal bulkheads in association with a non-primary centreline docking girder.
- (iii) Double bottom.

(b) Wing tank structure:

- (i) Transverse ring structure consisting of bottom, side shell, longitudinal bulkhead and deck transverses and incorporating one cross-tie or no cross-ties in tankers not exceeding 75 m in length.
- (ii) Double bottom.

2.1.2 The requirements are also applicable to structural arrangements incorporating a single longitudinal bulkhead located on the ship's centreline without cross-ties, for tankers not exceeding 75 m in length.

2.1.3 The minimum thickness and constructional detail requirements of *Pt 4, Ch 10, 7 Construction details and minimum thickness* are to be complied with. Particular attention is to be paid to the design of end connections between primary members and buttresses. The shear and combined stress levels in these connections are to be examined and should be within the limits specified in *ShipRight SDA Procedure - Guidance Notes on Direct Calculations*.

2.2 Symbols

2.2.1 The symbols used in this Section are defined as follows:

b_{e1}, b_{e2} = effective end bracket leg length, in metres, at each end of the member, see *Pt 3, Ch 3, 3 Structural idealisation*

b_T = overall breadth of tank, in metres

h_b = $0,75D + 2,45$ m

h_c = vertical distance from the centre of the cross-tie to deck at side amidships, in metres

h_s = distance between the lower span point of the side transverse and the moulded deck line at side, in metres

l_c = one-half the vertical distance, in metres, between the cross tie and the centre of the adjacent bottom or deck transverse, or double bottom, see *Figure 10.2.3 Wing tank construction*

l_T = overall length of tank, in metres

s = spacing of transverses, in metres

A = net sectional area of the web including end bracket where applicable, in cm^2

I_G = moment of inertia of the girder, in cm^4

I_T = moment of inertia of the transverse, in cm^4

Q_x = shear force at the actual section under consideration, obtained from shear force diagrams constructed as indicated, in kN (tonne-f)

S_c = length of cross-tie between the face plates on the vertical transverse webs at the cross ties, in metres

S_G = span of girder, in metres, and is in no case to be taken less than $(l_T - 1,8s)$ metres

S_s = span of the side transverses, in metres, and is to be measured between end span points, see *Figure 10.2.3 Wing tank construction*

S_T = span of transverses, in metres

2.2.2 Other symbols are defined in *Pt 4, Ch 9, 1.6 Information required for CSR Double Hull Oil Tankers*.

2.3 Structural arrangements

2.3.1 The spacing of transverses is not to exceed 3,6 m.

2.3.2 Where a trunk is fitted, the scantlings of primary members are to be modified as required by *Pt 4, Ch 10, 6 Trunked construction*.

2.4 Bottom structure coefficients

2.4.1 Where a primary supporting bottom centreline girder is fitted, in a single bottom, the requirements for the girder and transverses may be derived using bending moment and shear force coefficients K_1 and K_2 determined from *Table 10.2.1 Bottom structure coefficients*. To obtain the coefficients, the following factors are required:

$$\alpha = \frac{l_T - S_G}{2S}$$

$$\beta = \frac{S^3_G I_T}{S^3_T I_G}$$

Initially, an estimated value of the ratio $\frac{I_T}{I_G}$ may be used, and an iterative process adopted to obtain the final required values.

2.4.2 Where bottom transverses are fitted in association with a non-primary centreline girder the coefficients for the transverse are to be taken as:

$$K_1 = 0,083$$

$$K_2 = 0,50$$

For the requirements for the non-primary girder, see Pt 4, Ch 10, 2.6 Bottom girders.

2.4.3 In ships with one longitudinal bulkhead, the coefficient for the bottom transverse is to be taken as:

(a) $K_1 = 0,177$.

2.5 Bottom transverses

2.5.1 The section modulus of bottom transverses is to be not less than:

$$Z = 62K_1 s h_b S_T k^2 \text{ cm}^3$$

2.5.2 In ships with two longitudinal bulkheads, the depth of the bottom transverse web plate is to be not less than $0,2S_T$ and the net sectional area of the web at any section, including vertical end connections, is to be not less than:

$$A = 0,12Q_x k \text{ cm}^2$$

$$\left(A = \frac{Q_x k}{0,85} \text{ cm}^2 \right)$$

where Q_x is calculated from shear force diagrams constructed as shown in Figure 10.2.1 Bottom transverses. For end connections, Q_x is to be determined by projection of the shear force diagram as indicated.

2.5.3 The moment of inertia of bottom transverses is to be not less than:

$$I = \frac{10,5}{k} S_T Z \text{ cm}^4$$

2.6 Bottom girders

2.6.1 The section modulus of the primary centreline bottom girder, where fitted, is to be not less than:

$$Z = 31K_1 b_T S_G h_b s k \text{ cm}^3$$

2.6.2 The net sectional area of the web at any section, including vertical end connections, is to be not less than:

$$A = 0,12Q_x k \text{ cm}^2$$

$$\left(A = \frac{Q_x k}{0,85} \text{ cm}^2 \right)$$

where Q_x is calculated from a shear force diagram constructed as shown in Figure 10.2.2 Bottom centreline girder. For end connections, Q_x is to be determined by projection of the shear force diagram as indicated.

2.6.3 In a single bottom the section modulus and web area of a non-primary centreline docking girder are to be not less than:

$$Z = 3,6b_T Ds^2 k \text{ cm}^3$$

$$A = 0,3b_T Ds k \text{ cm}^2$$

The scantlings of this girder may, however, be required to be increased, depending upon the docking condition and support arrangements, details of which are to be submitted. Consideration may be required to be given to restricting the level of ballast tank filling for docking purposes. The loads are to be specially considered when wing tanks are ballasted for docking.

2.6.4 Consideration will be given to alternative methods of stiffening in way of the keel blocks when accompanied by supporting calculations.

2.6.5 In way of the vertical centreline web and centreline supports to horizontal girders of transverse bulkheads, the docking girder is to be increased in depth and scantlings as necessary to provide an effective support.

2.7 Side transverses

2.7.1 The section modulus of side transverses in ships with one or two longitudinal bulkheads is to be not less than:

$$Z = K_3sh_sS_3k^2 \text{ cm}^3$$

where K_3 is given in Table 10.2.2 Side transverse coefficients.

Table 10.2.1 Bottom structure coefficients

(a) 1 GIRDER, 2 TRANSVERSES												
β	Girder											
	K_1						K_2					
	α						α					
	0,0	0,2	0,4	0,6	0,8	1,0	0,0	0,2	0,4	0,6	0,8	1,0
0,02	0,210	0,210	0,195	0,175	0,125	0,0	1,000	1,000	1,000	1,000	1,000	1,000
0,04	0,210	0,210	0,195	0,175	0,125	0,0	0,960	0,960	0,980	1,000	1,000	1,000
0,06	0,210	0,210	0,195	0,170	0,125	0,0	0,940	0,940	0,960	0,980	1,000	1,000
0,08	0,205	0,205	0,190	0,167	0,125	0,0	0,920	0,920	0,940	0,970	1,000	1,000
0,10	0,200	0,200	0,185	0,165	0,125	0,0	0,900	0,900	0,920	0,960	0,990	1,000
0,20	0,180	0,180	0,170	0,150	0,120	0,0	0,800	0,820	0,860	0,920	0,980	1,000
0,40	0,150	0,150	0,150	0,135	0,115	0,0	0,670	0,730	0,760	0,840	0,950	1,000
0,60	0,130	0,130	0,135	0,125	0,110	0,0	0,580	0,630	0,690	0,790	0,910	1,000
0,80	0,120	0,120	0,120	0,120	0,105	0,0	0,520	0,540	0,630	0,730	0,880	1,000
1,00	0,100	0,100	0,115	0,115	0,100	0,0	0,460	0,500	0,580	0,680	0,850	1,000
	Transverses											
0,02	0,022	0,022	0,022	0,022	0,021	0,020	0,255	0,255	0,255	0,255	0,250	0,250
0,04	0,023	0,023	0,023	0,022	0,021	0,020	0,263	0,263	0,257	0,255	0,250	0,250
0,06	0,025	0,025	0,023	0,022	0,021	0,020	0,265	0,265	0,263	0,260	0,250	0,250
0,08	0,026	0,026	0,024	0,023	0,021	0,020	0,270	0,270	0,267	0,260	0,253	0,250
0,10	0,027	0,027	0,025	0,023	0,022	0,020	0,275	0,275	0,270	0,263	0,255	0,250
0,20	0,033	0,033	0,029	0,026	0,023	0,020	0,300	0,300	0,285	0,272	0,257	0,250
0,40	0,041	0,041	0,036	0,032	0,025	0,020	0,330	0,330	0,307	0,287	0,265	0,250
0,60	0,047	0,047	0,041	0,036	0,026	0,020	0,355	0,355	0,325	0,302	0,273	0,250
0,80	0,051	0,051	0,045	0,038	0,028	0,020	0,370	0,370	0,342	0,315	0,278	0,250
1,00	0,054	0,054	0,048	0,041	0,030	0,020	0,385	0,385	0,355	0,327	0,285	0,250

Single Hull Oil Tankers

Part 4, Chapter 10

Section 2

(b) 1 GIRDER, 3 TRANSVERSES												
β	Girder											
	K_1						K_2					
	α						α					
	0,0	0,2	0,4	0,6	0,8	1,0	0,0	0,2	0,4	0,6	0,8	1,0
0,02	0,290	0,290	0,290	0,270	0,200	0,120	1,400	1,400	1,500	1,500	1,500	1,500
0,04	0,290	0,290	0,290	0,270	0,200	0,120	1,400	1,400	1,500	1,500	1,500	1,500
0,06	0,290	0,290	0,290	0,260	0,200	0,120	1,380	1,400	1,500	1,500	1,500	1,500
0,08	0,280	0,280	0,280	0,250	0,195	0,115	1,340	1,370	1,470	1,470	1,480	1,500
0,10	0,275	0,275	0,275	0,240	0,190	0,115	1,320	1,340	1,420	1,440	1,460	1,480
0,20	0,245	0,245	0,245	0,220	0,175	0,105	1,180	1,210	1,280	1,330	1,380	1,450
0,40	0,200	0,200	0,200	0,185	0,160	0,090	0,970	1,030	1,080	1,200	1,280	1,420
0,60	0,170	0,170	0,170	0,170	0,145	0,080	0,840	0,900	0,960	1,110	1,210	1,380
0,80	0,150	0,150	0,150	0,150	0,135	0,075	0,740	0,800	0,870	1,040	1,150	1,330
1,00	0,135	0,135	0,135	0,135	0,125	0,070	0,680	0,740	0,810	0,960	1,100	1,300
Transverses												
0,02	0,025	0,025	0,024	0,023	0,022	0,022	0,258	0,258	0,257	0,252	0,252	0,252
0,04	0,026	0,026	0,025	0,024	0,023	0,023	0,267	0,267	0,267	0,262	0,262	0,260
0,06	0,028	0,028	0,026	0,026	0,025	0,024	0,275	0,275	0,275	0,270	0,270	0,265
0,08	0,030	0,030	0,028	0,028	0,026	0,026	0,285	0,285	0,280	0,272	0,272	0,272
0,10	0,032	0,032	0,029	0,029	0,028	0,027	0,292	0,292	0,287	0,277	0,275	0,275
0,20	0,040	0,040	0,037	0,035	0,033	0,032	0,325	0,325	0,315	0,310	0,300	0,282
0,40	0,052	0,052	0,049	0,046	0,041	0,039	0,372	0,372	0,360	0,345	0,332	0,320
0,60	0,059	0,059	0,057	0,054	0,048	0,045	0,405	0,405	0,392	0,375	0,357	0,342
0,80	0,065	0,065	0,063	0,059	0,053	0,049	0,425	0,425	0,415	0,390	0,377	0,360
1,00	0,069	0,069	0,066	0,063	0,056	0,052	0,440	0,440	0,432	0,415	0,395	0,375

(c) 1 GIRDER, 4 TRANSVERSES												
β	Girder											
	K_1						K_2					
	α						α					
	0,0	0,2	0,4	0,6	0,8	1,0	0,0	0,2	0,4	0,6	0,8	1,0
0,02	0,370	0,350	0,330	0,315	0,275	0,215	1,890	1,890	1,920	1,940	1,960	1,990
0,04	0,370	0,350	0,330	0,315	0,275	0,215	1,870	1,870	1,900	1,930	1,940	1,960
0,06	0,360	0,350	0,330	0,310	0,270	0,205	1,820	1,820	1,870	1,890	1,920	1,940
0,08	0,350	0,340	0,320	0,300	0,260	0,200	1,760	1,800	1,820	1,840	1,880	1,920
0,10	0,340	0,330	0,315	0,290	0,255	0,195	1,700	1,750	1,790	1,830	1,860	1,900
0,20	0,300	0,300	0,275	0,260	0,230	0,180	1,500	1,580	1,630	1,700	1,780	1,820

Single Hull Oil Tankers

Part 4, Chapter 10

Section 2

0,40	0,240	0,240	0,230	0,220	0,200	0,155	1,240	1,300	1,400	1,540	1,620	1,700
0,60	0,200	0,200	0,200	0,200	0,175	0,135	1,060	1,120	1,250	1,400	1,500	1,600
0,80	0,175	0,175	0,175	0,175	0,165	0,120	0,940	1,000	1,150	1,270	1,420	1,520
1,00	0,150	0,150	0,150	0,150	0,150	0,105	0,850	0,920	1,050	1,200	1,340	1,460
Transverses												
0,02	0,025	0,025	0,024	0,024	0,023	0,023	0,255	0,255	0,255	0,255	0,253	0,250
0,04	0,027	0,026	0,026	0,025	0,025	0,024	0,272	0,270	0,268	0,266	0,260	0,255
0,06	0,029	0,029	0,028	0,027	0,026	0,025	0,282	0,280	0,275	0,272	0,270	0,263
0,08	0,031	0,031	0,030	0,028	0,028	0,027	0,292	0,287	0,285	0,280	0,275	0,270
0,10	0,033	0,033	0,032	0,030	0,029	0,028	0,300	0,295	0,290	0,285	0,280	0,275
0,20	0,042	0,041	0,039	0,037	0,035	0,033	0,335	0,325	0,320	0,313	0,307	0,300
0,40	0,053	0,051	0,050	0,047	0,044	0,041	0,380	0,372	0,362	0,352	0,342	0,330
0,60	0,061	0,059	0,057	0,054	0,050	0,047	0,412	0,405	0,387	0,376	0,365	0,355
0,80	0,066	0,065	0,062	0,058	0,054	0,051	0,435	0,425	0,412	0,400	0,382	0,370
1,00	0,070	0,068	0,065	0,062	0,058	0,055	0,450	0,437	0,427	0,412	0,395	0,385

(d) 1 GIRDER, 5 TRANSVERSES

β	Girder											
	K_1						K_2					
	α						α					
	0,0	0,2	0,4	0,6	0,8	1,0	0,0	0,2	0,4	0,6	0,8	1,0
0,02	0,455	0,440	0,410	0,380	0,345	0,300	2,330	2,350	2,370	2,400	2,420	2,450
0,04	0,445	0,430	0,410	0,380	0,345	0,300	2,310	2,340	2,360	2,380	2,410	2,440
0,06	0,430	0,415	0,395	0,370	0,340	0,295	2,250	2,290	2,300	2,340	2,380	2,400
0,08	0,415	0,400	0,385	0,365	0,330	0,290	2,180	2,230	2,280	2,290	2,340	2,360
0,10	0,400	0,390	0,375	0,355	0,320	0,280	2,110	2,170	2,200	2,240	2,300	2,320
0,20	0,345	0,340	0,330	0,315	0,285	0,250	1,840	1,920	2,000	2,040	2,130	2,180
0,40	0,270	0,265	0,265	0,265	0,235	0,200	1,500	1,600	1,700	1,790	1,900	1,970
0,60	0,220	0,220	0,220	0,220	0,200	0,165	1,280	1,380	1,500	1,610	1,650	1,840
0,80	0,185	0,185	0,185	0,185	0,175	0,140	1,140	1,230	1,370	1,500	1,620	1,740
1,00	0,165	0,165	0,165	0,165	0,160	0,125	1,040	1,140	1,280	1,420	1,540	1,650
Transverses												
0,02	0,025	0,025	0,025	0,024	0,024	0,023	0,265	0,265	0,263	0,260	0,257	0,255
0,04	0,028	0,028	0,028	0,027	0,026	0,025	0,280	0,280	0,275	0,270	0,267	0,265
0,06	0,031	0,031	0,030	0,029	0,028	0,027	0,290	0,287	0,284	0,280	0,277	0,275
0,08	0,034	0,034	0,033	0,032	0,031	0,030	0,303	0,300	0,295	0,290	0,287	0,283
0,10	0,037	0,036	0,036	0,034	0,033	0,032	0,312	0,309	0,305	0,300	0,297	0,292
0,20	0,046	0,046	0,045	0,043	0,043	0,041	0,352	0,349	0,343	0,337	0,330	0,325

0,40	0,060	0,058	0,057	0,055	0,054	0,053	0,405	0,402	0,393	0,383	0,378	0,375
0,60	0,068	0,067	0,065	0,064	0,063	0,061	0,435	0,432	0,426	0,417	0,412	0,407
0,80	0,073	0,072	0,071	0,069	0,068	0,067	0,455	0,452	0,446	0,440	0,436	0,432
1,00	0,077	0,076	0,074	0,073	0,071	0,070	0,470	0,467	0,461	0,455	0,450	0,445

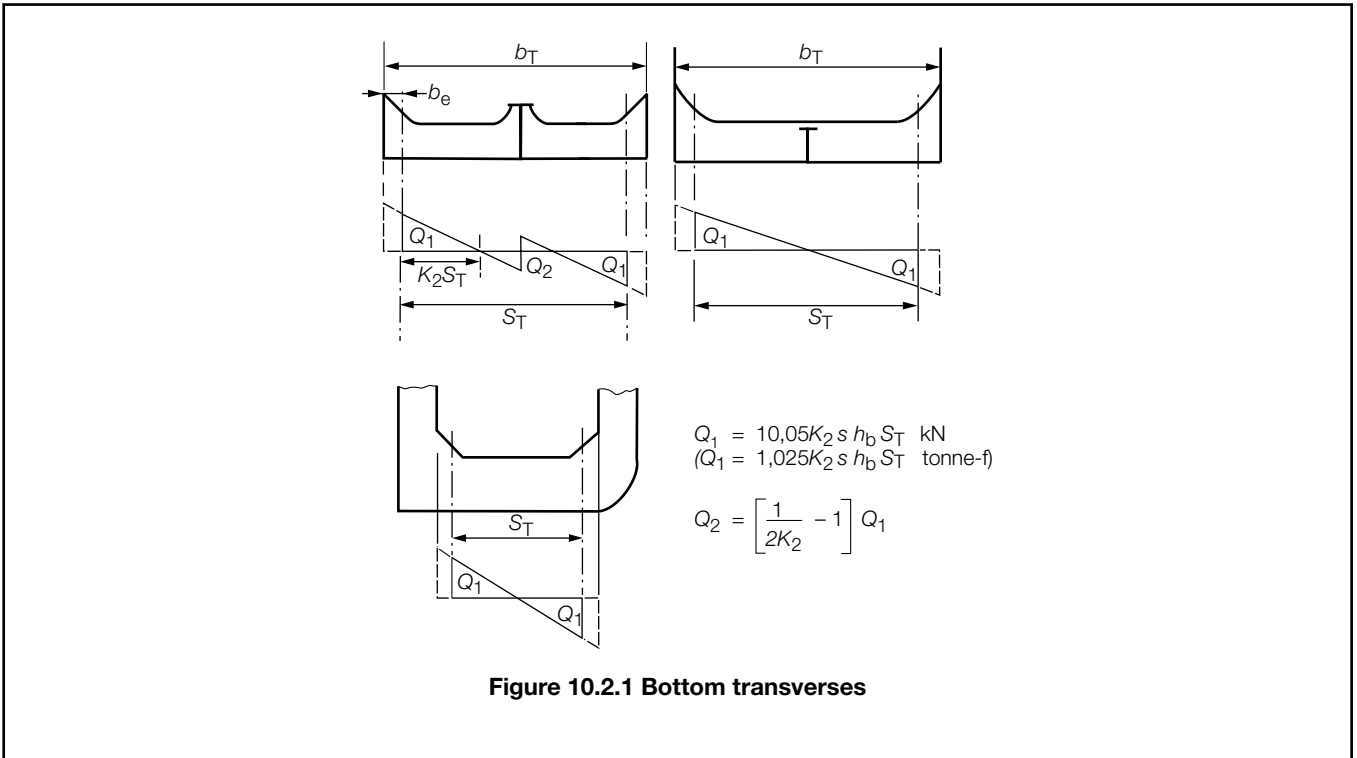
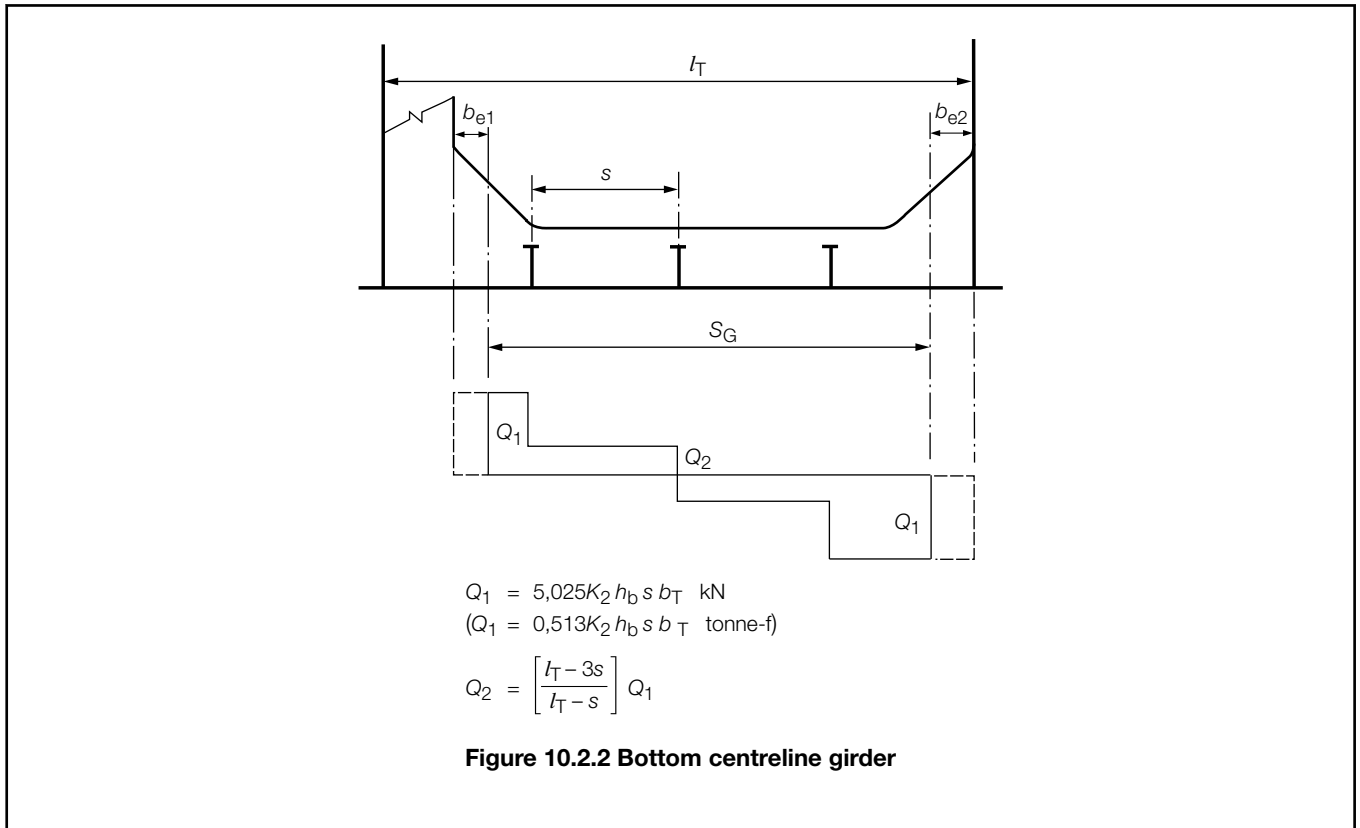

Figure 10.2.1 Bottom transverses



2.7.2 In ships with two longitudinal bulkheads, the net sectional area of the web at any section is to be not less than:

$$A = 0,12Q_x k \text{ cm}^2$$

$$\left(A = \frac{Q_x k}{0,85} \text{ cm}^2 \right)$$

where Q_x is calculated from shear force diagrams constructed as shown in *Figure 10.2.3 Wing tank construction*. For this purpose the values of K_4 and K_5 and the range of application is given in *Table 10.2.2 Side transverse coefficients*.

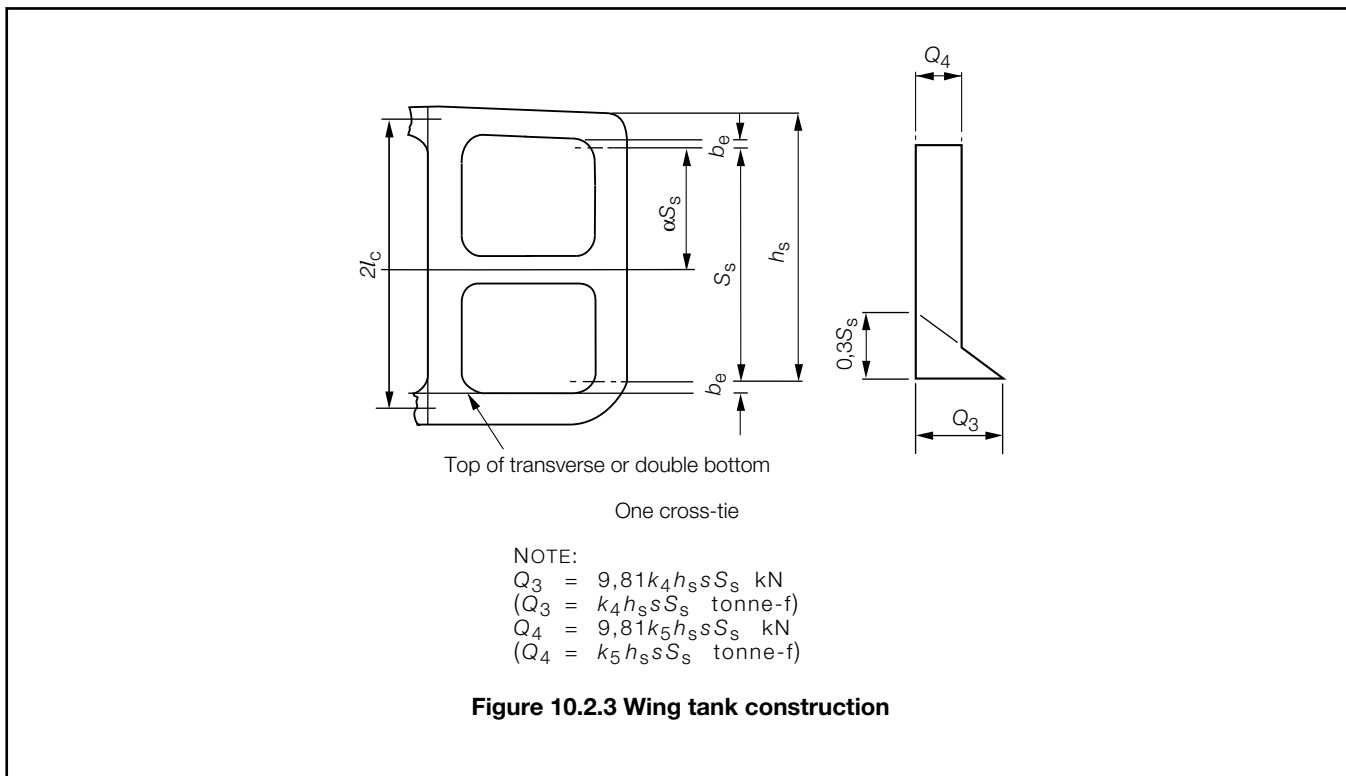

2.7.3 The moment of inertia of side transverses is to be not less than:

$$I = \frac{7,5}{k} S_s Z \text{ cm}^4.$$

2.8 Deck transverses

2.8.1 The section modulus of deck transverses is to be not less than:

$$Z = 53,75(0,0269sL + 0,8)(S_T + 1,83)k \text{ cm}^3$$

Where a continuous deck girder is fitted, the term S_T in the above formula is to be replaced by $\frac{S_T}{2}$.

Table 10.2.2 Side transverse coefficients

Number of cross-ties	K_3	K_4	K_5	Range of application
0	8	Not applicable		$L \leq 75$ m, see Pt 4, Ch 10, 2.3 Structural arrangements
1	2,16	0,455 - 0,316 α	0,103	0,5 $\leq \alpha \leq$ 0,7

2.8.2 The net sectional area of the web is to satisfy the requirements of Pt 4, Ch 10, 2.5 Bottom transverses 2.5.2 using a head, $h_b = \frac{L_1}{56}$ m.

2.8.3 The moment of inertia of the transverses is to be not less than:

$$I = \frac{7,5}{k} S_T Z \text{ cm}^4.$$

2.9 Deck girders

2.9.1 Where a continuous deck centreline girder supporting deck transverses is fitted, it is to have a section modulus not less than:

$$Z = 0,0476S_G^2 b_T \text{ cm}^3$$

2.9.2 The net sectional area of the web is to satisfy the requirements of *Pt 4, Ch 10, 2.6 Bottom girders 2.6.2* using a head, $h_b = \frac{L_1}{56}$ m.

2.9.3 In way of the vertical centreline web on transverse bulkheads, the continuous deck girder is to be increased in depth and scantlings as necessary to provide an effective support.

2.9.4 Where an intercostal deck girder is fitted, it is to have a depth not less than 50 per cent of the depth of the deck transverse and the area of the face flat is to be not less than that of the transverse.

2.9.5 In way of the vertical centreline web and centreline supports to horizontal girder on transverse bulkheads, the intercostal deck girder may be required to be increased in depth and scantlings to provide an effective support.

2.10 Cross-ties

2.10.1 Cross-ties, where fitted, may be of plate or sectional material and are to have an area and least moment of inertia not less than:

$$A = (64 + 1,035l_c h_c s)k \text{ cm}^2$$

$$I = 2,45l_c h_c s^2 \text{ cm}^4.$$

2.10.2 Design of end connections is to be such that the area of the welding, including vertical brackets, where fitted, is to be not less than the minimum cross-sectional area of the cross tie derived from *Pt 4, Ch 10, 2.10 Cross-ties 2.10.1*. To achieve this full penetration may be required and thickness of brackets may require further consideration. Attention is to be given to the full continuity of area of the backing structure on the transverses. Particular attention is also to be paid to the welding at the toes of all vertical end brackets on the cross-tie.

2.11 Double bottom girders and floors

2.11.1 The scantlings of girder and floors are to satisfy the requirements of *Pt 4, Ch 1, 8.3 Girders* and *Pt 4, Ch 1, 8.5 Floors* respectively for longitudinally framed ships.

■ **Section 3**
Primary members supporting transverse side framing

3.1 General

3.1.1 The requirements of this Section are applicable to side stringers and transverse webs associated with transverse framing.

3.1.2 The minimum thickness and constructional detail requirements of *Pt 4, Ch 10, 7 Construction details and minimum thickness* are to be complied with.

3.2 Symbols

3.2.1 The symbols used in this Section are defined as follows:

h_1 = head, in metres, from stringer to highest point of tank excluding hatchway, but not less than 2,5 m

Q_x = shear force at the actual section under consideration, obtained from shear force diagrams constructed as indicated, in kN (tonne-f)

S_1 = span, in metres, of the horizontal girder measured between span points, but to be taken not less than the lesser of $(1,2 + 0,02L)$ m or 3 m.

3.2.2 Other symbols are defined in *Pt 4, Ch 9, 1.6 Information required for CSR Double Hull Oil Tankers*.

3.3 Structural arrangements

3.3.1 Side shell stringers are to be fitted as required by *Table 10.3.1 Requirements for stringers*. Alternatively, the number of stringers may be derived by direct calculation, particular regard being given to secondary bending effects on the frames supported.

Table 10.3.1 Requirements for stringers

Ship depth, in metres	Number of stringers
$D \leq 6,0$	0
$6,0 < D \leq 7,5$	1
$7,5 < D \leq 11,0$	2

3.3.2 Where the spacing of bulkheads (oiltight or non-oiltight) exceeds 15 m, side transverses are to be fitted in line with each bottom transverse.

3.3.3 Where side transverses are not required, bottom transverses are to be adequately supported at the side shell and longitudinal bulkhead, and the lower side stringer is to be suitably buttressed from the bottom transverse.

3.3.4 Cross-ties, where fitted, are to comply with the requirements of 2.10 and are, in general, to be aligned with the stringers.

3.3.5 Where the ship is fitted with a trunk, the scantlings as given in this Section are to be modified as required by *Pt 4, Ch 10, 6 Trunked construction*.

3.4 Scantlings

3.4.1 The section modulus of side stringers is to be not less than:

$$Z = 10bh_1S_1k^2 \text{ cm}^3.$$

3.4.2 The net sectional area of the web at any section is to be not less than:

$$A = 0,12Q_xk \text{ cm}^2$$

$$\left(A = \frac{Q_xk}{0,85} \text{ cm}^2 \right)$$

where Q_x is calculated from a shear force diagram constructed using the shear force at the span point, Q_1 given by the following:

$$Q_1 = 5,03sh_1S_1 \text{ kN}$$

$$(Q_1 = 0,513sh_1S_1 \text{ tonne-f}).$$

3.4.3 The moment of inertia of the stringer is to be not less than:

$$I = S_1Z \frac{7,5}{k} \text{ cm}^4.$$

3.4.4 Where side transverses supporting side stringers are fitted, they are to have a section modulus not less than that required by *Pt 4, Ch 10, 2.7 Side transverses*. Where the side transverse does not support side stringers, the section modulus required by *Pt 4, Ch 10, 2.7 Side transverses* may be reduced by 20 per cent.

■ **Section 4**
Primary members supporting oiltight bulkheads

4.1 General

4.1.1 These requirements are applicable to ships having two longitudinal bulkheads, and to ships not exceeding 75 m in length having one longitudinal bulkhead located on the centreline of the ship.

4.1.2 The minimum thickness and construction detail requirements of *Pt 4, Ch 10, 7 Construction details and minimum thickness* are to be complied with. Particular attention is to be paid to the design of end connections between primary members and buttresses. Where considered necessary, the shear and combined stresses in the connections may require to be examined and the scantlings and stiffening increased.

4.2 Symbols

4.2.1 The symbols used in this Section are defined as follows:

h = the distance from the centre of the load on the member to a point 2,45 m above the highest point of the tank, excluding the hatchway, in metres

Q_x = shear force at the actual section under consideration, obtained from shear force diagrams constructed as indicated, in kN (tonne-f).

4.2.2 Other symbols are defined in *Pt 4, Ch 9, 1.6 Information required for CSR Double Hull Oil Tankers*.

4.3 Structural arrangements

4.3.1 Where horizontal girders and vertical webs do not form part of a ring structure, they are to be arranged with substantial end brackets forming a buttress extending to the adjacent vertical web or transverse.

4.3.2 Where the cross-ties are omitted from the transverse ring in the wing tank adjacent to the bulkhead, the design of the horizontal girder, of the end buttress and of the transverse is to take account of the loads imposed and the deflection of the structure.

4.3.3 The spacing of transverses on longitudinal bulkheads is not to exceed 3,6 m.

4.3.4 Where, on ships with transverse side framing, transverses are required by *Pt 4, Ch 10, 3 Primary members supporting transverse side framing*, vertical webs are also to be fitted in line on the longitudinal bulkhead. Where such vertical webs are not required the lower horizontal girder on the bulkhead is to be suitably buttressed from the bottom transverses.

4.4 Scantlings

4.4.1 The scantlings of vertical webs on longitudinal bulkheads are to be as required for side transverses by *Pt 4, Ch 10, 2 Primary members supporting longitudinal framing*.

4.4.2 The section modulus of vertical webs on transverse bulkheads and of horizontal girders is to be not less than:

$$Z = 8bhl^2_e k \text{ cm}^3.$$

4.4.3 The net sectional area of the web at any section is to be not less than:

$$A = 0,12Q_x k \text{ cm}^2$$

$$\left(A = \frac{Q_x k}{0,85} \text{ cm}^2 \right)$$

where Q_x is the shear force at the section. For the horizontal girders on ships with two longitudinal bulkheads, Q_x is calculated from shear force diagrams as shown in *Figure 10.4.1 Horizontal girders*. For end connections, Q_x is to be determined by projection of the shear force diagrams as indicated.

4.4.4 The moment of inertia of vertical webs and horizontal girders is to be not less than:

$$I = \frac{10,5}{k} l_e Z^2 \text{ cm}^4.$$

4.4.5 For the calculation of section modulus, the minimum span of horizontal girders on longitudinal bulkheads is to be taken as not less than the lesser of $(1,2 + 0,02L)$ m or 3 m.

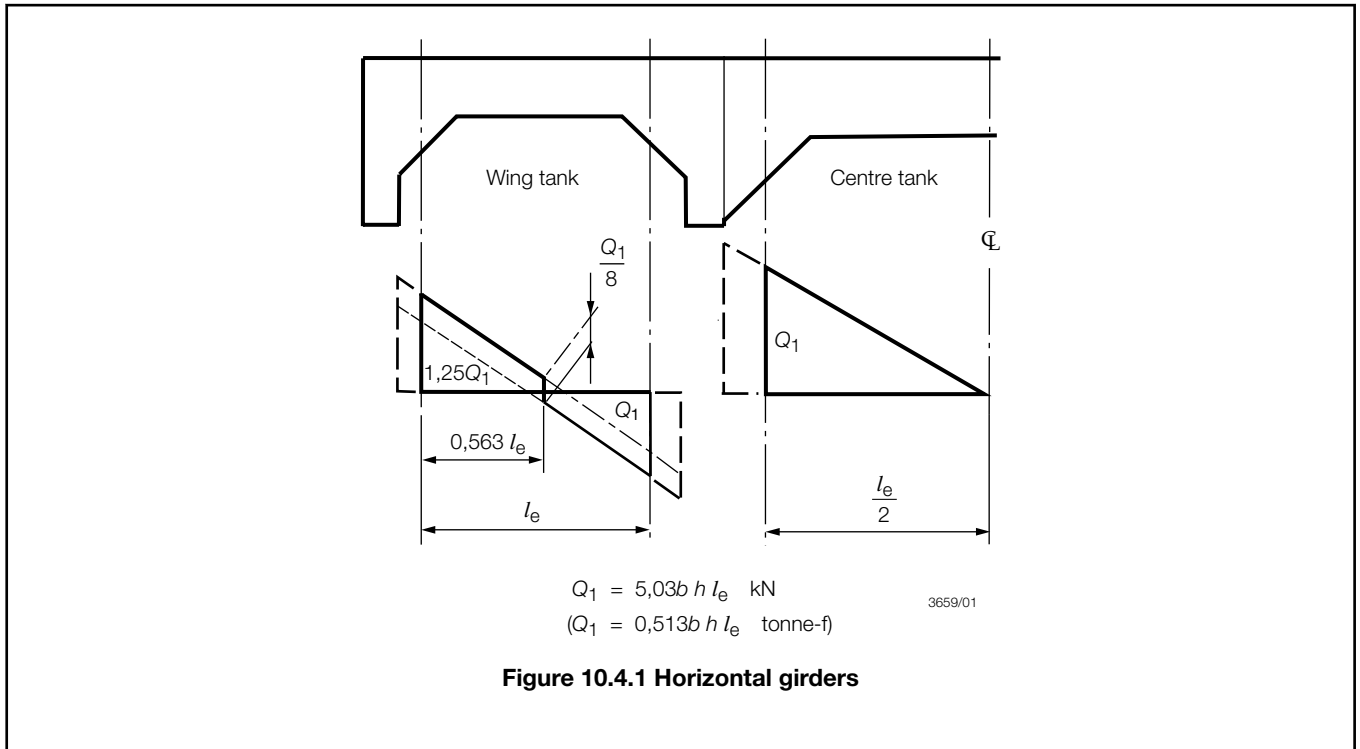

4.4.6 Where a trunk is fitted, the scantlings of primary members are to be modified as required by Pt 4, Ch 10, 6 Trunked construction.

■ **Section 5**
Primary members supporting non-oiltight bulkheads

5.1 General

5.1.1 These requirements are applicable to primary members supporting non-oiltight transverse bulkheads. Where non-oiltight longitudinal bulkheads are proposed, the requirements for the primary members will be individually considered.

5.1.2 The minimum thickness and constructional detail requirements of Pt 4, Ch 10, 7 Construction details and minimum thickness are to be complied with.

5.2 Symbols

5.2.1 The symbol, l_b , used in this Section is defined as follows:

l_b = the distance, in metres, between the transverse bulkheads (oiltight or non-oiltight) adjacent to the bulkhead under consideration.

5.2.2 Other symbols are defined in Pt 4, Ch 9, 1.6 Information required for CSR Double Hull Oil Tankers.

5.3 Direct calculations

5.3.1 Direct calculation procedures will generally be required where the non-oiltight bulkhead primary members will interact with, or tend to support, the primary bottom, longitudinal bulkhead or side structure, and in other cases where warranted by structural design features.

5.4 Scantlings and arrangements

5.4.1 The section modulus of vertical webs is to be not less than that required for a vertical web on an oiltight transverse bulkhead in the same position, see *Pt 4, Ch 10, 4 Primary members supporting oiltight bulkheads*, multiplied by the factor $\left(0,3 + 2\frac{l_b}{L}\right)$.

5.4.2 The section modulus of horizontal girders is to be not less than:

$$Z = 145kb l^2 \frac{l_b}{e L} \text{ cm}^3.$$

5.4.3 When determining the width of plating supported and the effective breadth for calculating the section modulus, no deduction is to be made on account of perforations.

■ **Section 6**
Trunked construction

6.1 General

6.1.1 The requirements of this Section are additional to those of *Pt 4, Ch 10, 1 General* to *Pt 4, Ch 10, 5 Primary members supporting non-oiltight bulkheads*.

6.1.2 Where a trunk is fitted it is to extend over the full length of the cargo tanks and is to be effectively scarfed into the main hull structure.

6.1.3 The minimum thickness and constructional detail requirements of *Pt 4, Ch 10, 7 Construction details and minimum thickness* are also to be complied with.

6.2 Symbols

6.2.1 The symbols used in this Section are defined as follows:

b_t = breadth of trunk, in metres

h_t = height of trunk, in metres, above the deck at the trunk side. Where the trunk top has excess camber, the value of h_t will be considered.

D_1 = equivalent depth of ship and is to be taken as:

$$D + 0,6\frac{b_t h_t}{B} \text{ where } \frac{b_t}{B} \leq 0,8 \text{ and}$$

$$D + h_t\left(2,6\frac{b_t}{B} - 1,6\right), \text{ where } \frac{b_t}{B} > 0,8$$

(see *Figure 10.6.1 Equivalent depth*).

6.2.2 Other symbols are defined in *Pt 4, Ch 9, 1.6 Information required for CSR Double Hull Oil Tankers*.

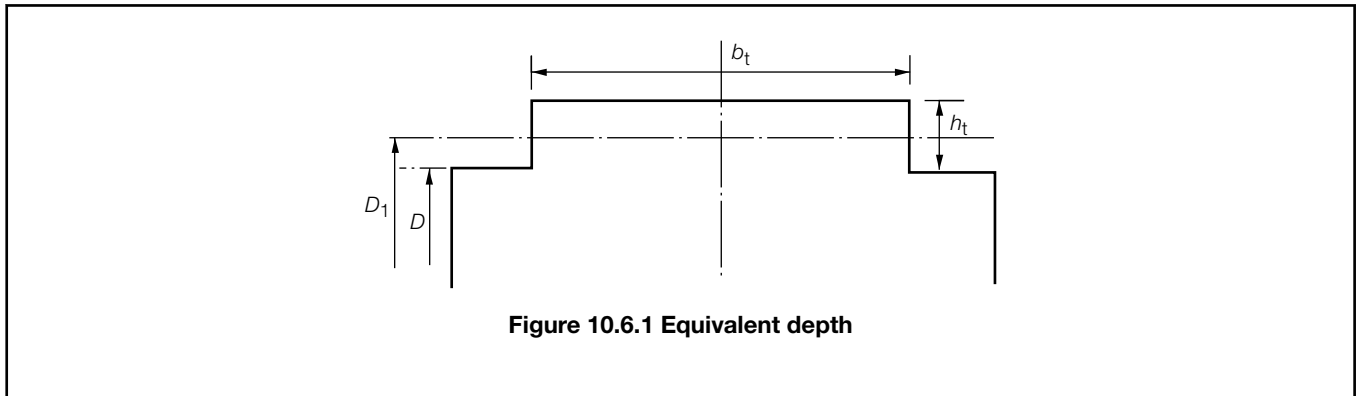

6.3 Structural arrangements

6.3.1 The trunk deck and sides are to be longitudinally framed, and the transverse primary members are to be aligned with the deck transverses.

6.3.2 Particular attention is to be given to the arrangements in way of the connection of the trunk side to the deck at side. The construction is to be such as to ensure adequate rigidity and continuity of strength.

6.3.3 Typical arrangements of primary structure are shown diagrammatically in *Figure 10.6.2 Primary structure*, which also indicates the effective spans to be used in the determination of scantlings.

6.3.4 Where the trunk primary stiffening is fitted externally, individual consideration will be given to the arrangement and scantlings.

6.3.5 Where longitudinal stiffening is fitted externally to the trunk, tripping brackets are to be fitted to maintain lateral stability in way of transverse bulkheads and elsewhere as necessary.

6.3.6 Extension brackets and web stiffeners or equivalent arrangements are to be provided at the forward and after ends of the trunk to ensure full continuity of strength from the trunk into hull and superstructures.

6.3.7 Where the carriage of heated cargoes is contemplated and, in particular, bituminous cargoes, special attention is to be given to the alignment of the scarfing arrangements and softening of the extension bracket toes at the trunk ends to alleviate the effects of thermal stressing.

6.4 Trunk scantlings

6.4.1 The thickness of the trunk top and side plating is to be not less than as required by *Pt 4, Ch 9, 4 Hull envelope plating* for hull envelope plating, the item numbers for these being as given in *Figure 10.6.3 Hull envelope plating - Itemisation of parts*.

6.4.2 The section modulus of trunk longitudinals is to be not less than as required by *Pt 4, Ch 9, 5 Hull framing* for deck longitudinals.

6.4.3 The section modulus and moment of inertia of the transverses is to be not less than as required by *Pt 4, Ch 10, 2.8 Deck transverses* for deck transverses.

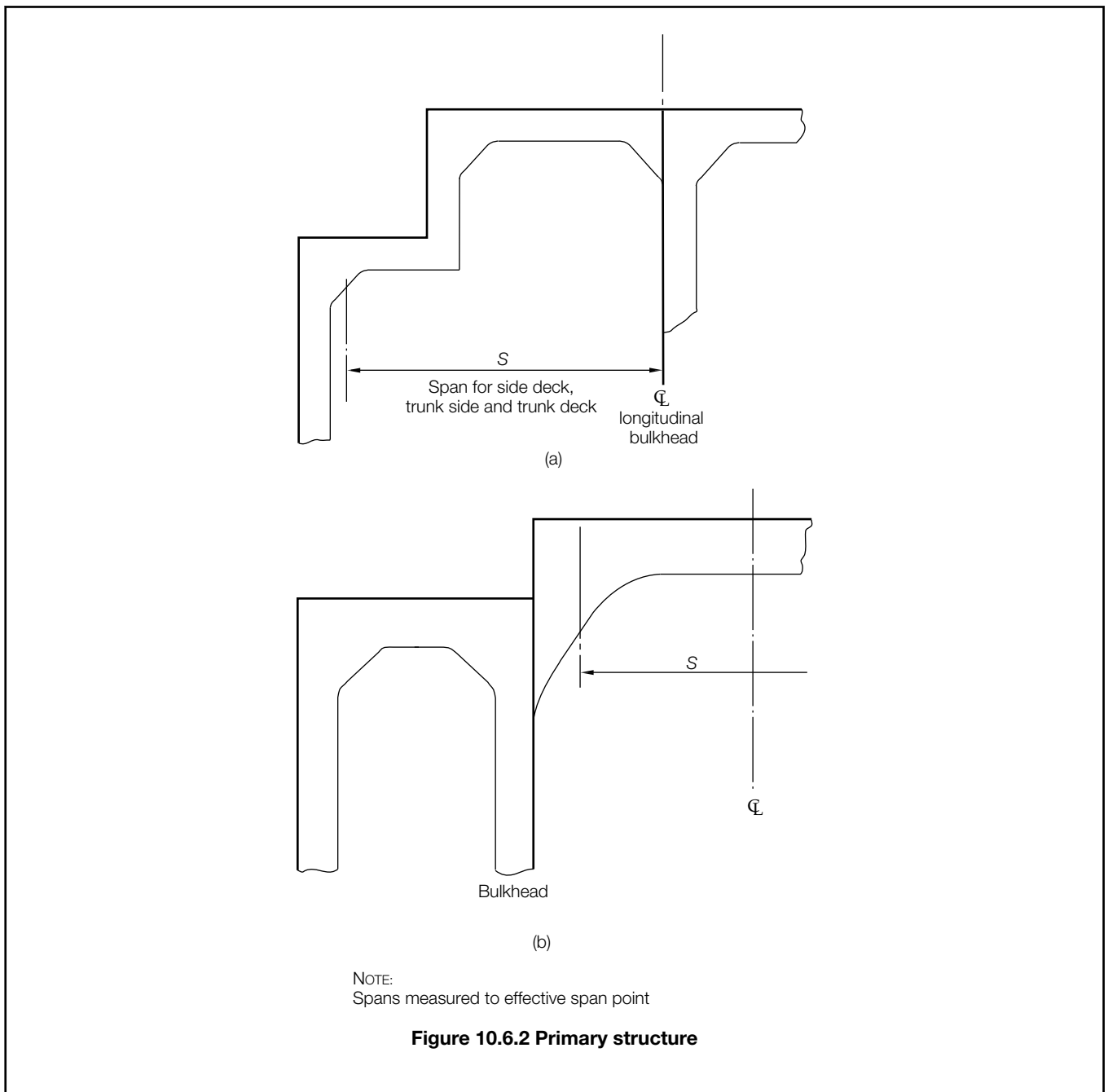

6.5 Modification to hull scantlings

6.5.1 The thickness of the deck plating outboard of the trunk side is to be that necessary to obtain the required hull section modulus, but is to be not less than that required by Pt 4, Ch 9, 4 Hull envelope plating multiplied by the factor

$$\frac{2BD}{2BD + b_t h_t}$$

6.5.2 The scantlings of the shell plating, framing, primary structure and bulkheads are to be determined on the basis of the equivalent ship depth D_1 , i.e. where the depth, D , enters into the calculation or structural arrangement it is to be replaced by D_1 .

6.5.3 The head to the deck at side is to be increased by $(D_1 - D)$.

6.5.4 The head to the highest point of the tank is to be replaced by the actual distance to the highest point of the tank, reduced by the amount $(D + h_t - D_1)$.

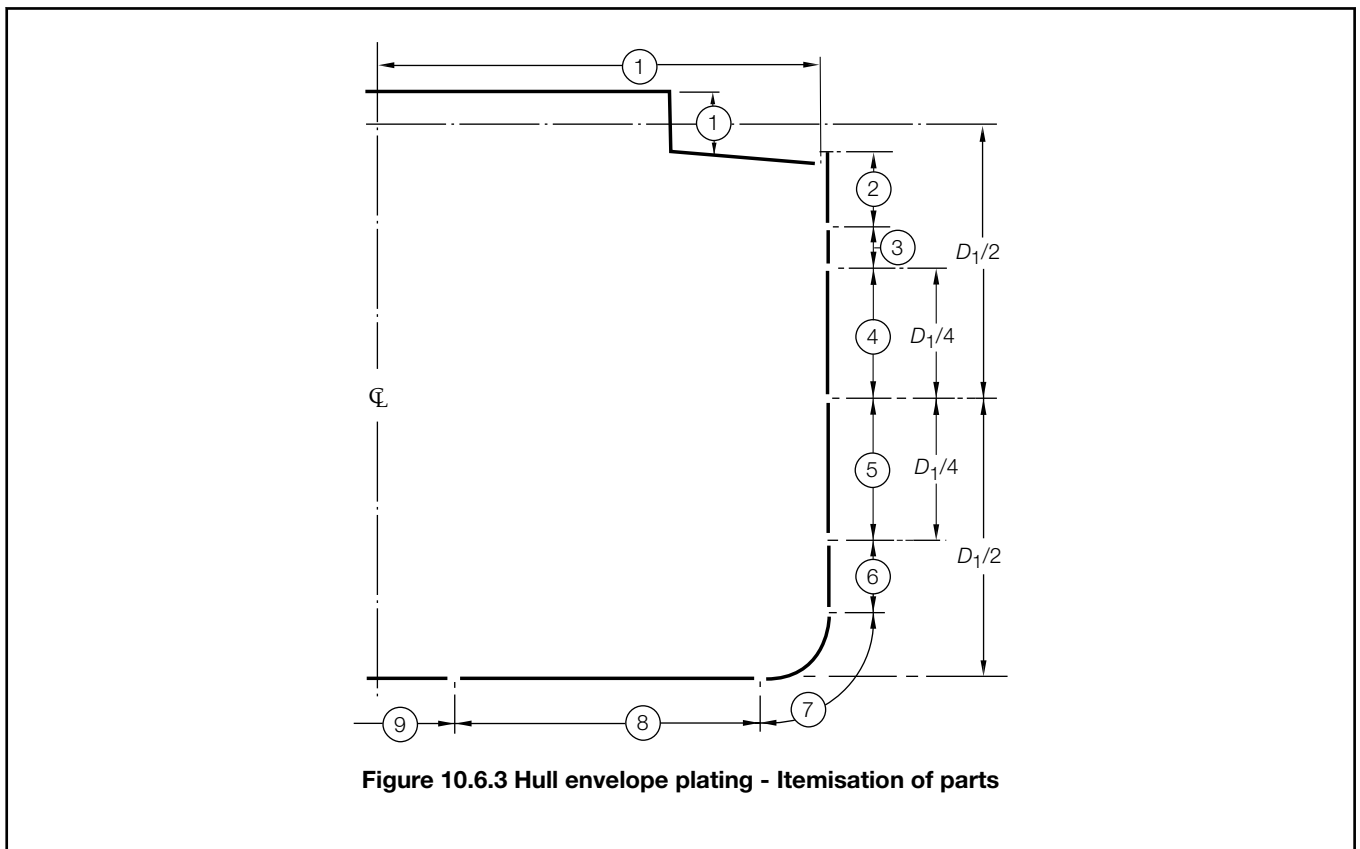

■ **Section 7**
Construction details and minimum thickness

7.1 Symbols

7.1.1 The symbols used in this Section are defined in *Pt 4, Ch 9, 10.1 Symbols*.

7.2 Compartment minimum thickness

7.2.1 The requirements of *Pt 4, Ch 9, 10.2 Compartment minimum thickness* are also applicable to small conventional single hull tankers.

7.3 Geometric properties and proportions of members

7.3.1 The depth of the web of any primary member is to be not less than 2,5 times the depth of the cut-outs for the passage of secondary members, except where compensation is arranged to provide satisfactory resistance to deflection and shear buckling in the web.

7.3.2 The area of material in the face plate of any primary member is not to exceed:

$$0,00667d_w t_w^2 \text{ cm}^2$$

nor is it to be less than:

$$0,0167s_t d_w^2 \text{ cm}^2 \text{ for the bottom centreline girder}$$

$$0,00417s_t d_w^2 \text{ cm}^2 \text{ elsewhere.}$$

7.3.3 The geometric properties of rolled stiffeners and built sections are to be calculated in association with an effective width of attached plating in accordance with *Pt 3, Ch 3, 3 Structural idealisation*.

7.4 Continuity of primary members

7.4.1 Primary members are to be so arranged as to ensure effective continuity of strength throughout the range of tank structure. Abrupt changes of depth or section are to be avoided. Where members abut on both sides of a bulkhead or on other members, arrangements are to be made to ensure that they are in alignment.

7.4.2 The members are to have adequate end fixity, lateral support and web stiffening, and the structure is to be arranged to minimize hard spots or other sources of stress concentration. Openings are to have well rounded corners and smooth edges and are to be located having regard to the stress distribution and buckling strength of the plate panel.

7.5 Primary member web plate stiffening

7.5.1 The webs of primary members are to be supported and stiffened in accordance with the following requirements, which are designated as requirements 'A', 'B', 'C' and 'D'. The application of these requirements is detailed in Pt 4, Ch 10, 7.5 Primary member web plate stiffening, and the corresponding locations indicated in Figure 10.7.1 Key to application requirements. Where webs are slotted for the passage of secondary members, the web stiffeners are to be arranged to provide adequate support for the loads transmitted, see Pt 3, Ch 10, 5.2 Arrangements at intersections of continuous secondary and primary members.

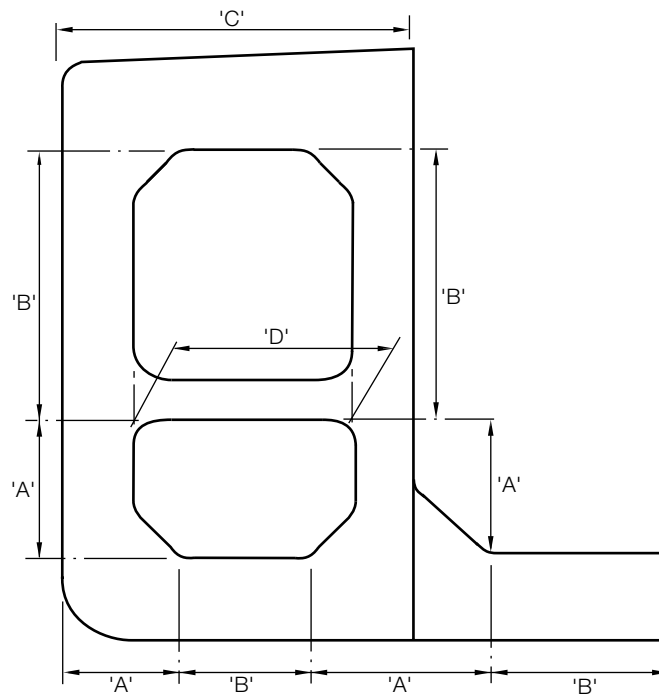

Figure 10.7.1 Key to application requirements

7.5.2 Where higher tensile steel is used for the primary members, the maximum spacing of stiffeners given in this Section is to be multiplied by \sqrt{k} .

7.5.3 In addition to these stiffeners, tripping brackets as required by Pt 4, Ch 9, 10.11 Lateral stability of primary members are also to be fitted.

7.5.4 For requirement 'A' stiffening:

- (a) The thickness, t_w of the web is to be not less than $\frac{s}{80}$
- (b) Stiffening is generally to be fitted normal to the face plate of the member, but the stiffeners parallel to the face plate will be required when the web depth, d_w , exceeds a value, d_{max} which is to be taken as:

$$fors \leq 55t_w \quad d_{max} = 3s$$

$$fors > 55t_w \quad d_{max} = \frac{45st_w}{s - 40t_w}$$

- (c) Where stiffening parallel to the face plate is required, the distance from the face plate of the member to the nearest stiffener is not to exceed $65t_w$. Further stiffeners are to be fitted at similar spacing so that the distance between the last stiffener and the shell or bulkhead plating does not exceed d_{max} . In way of end brackets to transverse bulkhead primary structure, stiffeners are to be fitted normal to the face plate of the member so that web plate panel dimensions parallel to the face plate do not exceed $80t_w$.

7.5.5 For requirement 'B' stiffening:

- (a) The thickness, t_w of the web is to be not less than $\frac{s}{85}$

- (b) Stiffening is generally to be fitted normal to the face plate of the member, but stiffeners parallel to the face plate will be required when the web depth, d_w , exceeds a value d_{max} , which is to be taken as:

$$fors \leq 70t_w \quad d_{max} = 3s$$

$$fors > 70t_w \quad d_{max} = \frac{48st_w}{s - 54t_w}$$

- (c) Where stiffening parallel to the face plate is required, the distance from the face plate of the member to the nearest stiffener is not to exceed $80t_w$. Further stiffeners are to be fitted at similar spacing so that the distance between the last stiffener and the shell or bulkhead plating does not exceed d_{max} .

7.5.6 For requirement 'C' stiffening:

- (a) Stiffening is generally to be fitted normal to the face plate of the member in line with alternate secondary members, but stiffeners parallel to the face plate will be required, when the web depth, d_w exceeds a value, d_{max} which is to be taken as:

$$fors \leq 76t_w \quad d_{max} = 3s$$

$$fors > 76t_w \quad d_{max} = \frac{48st_w}{s - 60t_w}$$

- (b) Where stiffening parallel to the face plate is required, the distance from the face plate of the member to the nearest stiffener is not to exceed $90t_w$. Further stiffeners are to be fitted at similar spacing so that the distance between the last stiffener and the deck plating does not exceed d_{max} .

7.5.7 For requirement 'D' stiffening:

- (a) Stiffening parallel to the face plate will be required such that the distance between the stiffener and face plate, or between two stiffeners, does not exceed:

$$80t_w \text{ where } L \leq 90 \text{ m}$$

$$55t_w \text{ where } L \geq 190 \text{ m}$$

with intermediate values by interpolation.

- (b) Brackets are to be fitted to support the face plates and stiffeners.

7.6 Inertia and dimensions of stiffeners

7.6.1 The moment of inertia is to be not less than:

- (a) For stiffeners normal to the primary member face plate:

$$I_s = pst_w^3 \times 10^{-4} \text{ cm}^4$$

Where t_w need not be greater than the values in *Table 10.7.1 Maximum web thickness for stiffener inertia* and p is to be obtained from *Table 10.7.2 Coefficient for stiffener inertia*.

- (b) For stiffeners parallel to the primary member face plate:

On transverses, webs and stringers

$$I_s = 2l_s A_s^2 \text{ cm}^4$$

On longitudinal deck and bottom girders

$$I_s = 2,85I_s A_s^2 \text{ cm}^4.$$

Table 10.7.1 Maximum web thickness for stiffener inertia

Requirement	Web thickness t_w , in mm
'A'	$\frac{s}{55}$
'B' and 'C'	$\frac{s}{70}$
'D'	$\frac{s}{80}$ where $L \leq 90m$, see Note $\frac{s}{60}$ where $L \leq 190m$, see Note
Note Intermediate values by interpolation	

7.6.2 Where stiffeners are fitted in both directions, the inertia of the stiffeners parallel to the face plate of the member is to be not less than that of the stiffeners fitted normally.

7.6.3 The depth of web stiffeners is to be not less than 75 mm.

7.6.4 Where flat bar stiffeners are used, the ratio of depth to thickness is not to exceed $18\sqrt{k}$.

Table 10.7.2 Coefficient for stiffener inertia

Aspect ratio of plate panel, $\frac{s}{d}$	1,0 or more	0,9	0,8	0,7	0,6	0,5	0,4	0,3 or less
ρ	1,5	2,1	2,9	4,2	6,1	9,2	14,6	30,0
Note 1. Intermediate values by interpolation.								
Note 2. The depth of panel, d , used in calculating aspect ratio may be measured from the face of the secondary member to which the primary member web stiffener is attached.								

7.7 Application of stiffening requirements

7.7.1 The requirements as detailed in Pt 4, Ch 10, 7.5 Primary member web plate stiffening and Pt 4, Ch 10, 7.6 Inertia and dimensions of stiffeners are to be applied in the following locations, see also Figure 10.7.1 Key to application requirements.

(a) For bottom transverses:

In the centre tank requirement 'A' stiffening is to extend for 20 per cent of the breadth of the tank from the longitudinal bulkhead, but at least beyond the toe of the end bracket. In the wing tank, requirement 'A' stiffening is to extend at least as far as the toes of the end brackets from the longitudinal bulkhead and the shell. Elsewhere, requirement 'B' stiffening is to be fitted.

(b) For transverses at side shell and longitudinal bulkhead:

Requirement 'A' stiffening is to extend at least as far as the lower surface of the lower cross-tie. Elsewhere, requirement 'B' stiffening is to be fitted.

(c) For deck transverses:

Requirement 'C' stiffening is to be fitted.

(d) For stringers and horizontal girders:

Requirement 'A' stiffening is to extend for a distance from each end of 20 per cent of the span of the stringer or girder, but at least beyond the toes of the end brackets. Elsewhere, requirement 'B' stiffening is to be fitted.

(e) For cross-ties:

Cross-ties are to be suitably stiffened to prevent buckling and twisting. Requirement 'D' stiffening is to be fitted.

(f) For shell stringers and vertical webs in fore peak:

Requirement 'A' stiffening is to extend the full length of the member.

7.7.2 The application of stiffening requirements to transverse wing structures in wing tanks where no cross-ties are fitted is to be based on the results of direct calculation and will be specially considered.

7.8 Stiffening of continuous longitudinal girders

7.8.1 The webs of continuous longitudinal deck and bottom girders are to be stiffened parallel to the girder face plate.

7.8.2 The stiffeners are to be spaced not more than $55t_w$ mm apart except in way of vertical webs and end brackets, where the spacing is not to exceed $45t_w$ mm. Alternatively, a combination of parallel stiffeners at $55t_w$ mm spacing and normal stiffeners at $45t_w$ mm spacing may be adopted. Particular attention is to be given to the stiffening of the docking girder.

7.8.3 The moment of inertia of stiffeners is to comply with *Pt 4, Ch 10, 7.6 Inertia and dimensions of stiffeners*.

7.9 Stiffening of vertical webs on transverse bulkheads

7.9.1 Vertical webs are to be fitted with stiffeners parallel to the face plate of the web and spaced not more than $60t_w$ mm apart. Stiffeners normal to the face plate are to be fitted when a vertical web supports horizontal stiffeners on transverse bulkheads. The length of stiffener is to be sufficient to distribute the load transmitted, and the connection between web stiffener and bulkhead stiffener is to comply with the relevant requirements of *Pt 3, Ch 10, 5.2 Arrangements at intersections of continuous secondary and primary members*.

7.9.2 The moment of inertia of the stiffeners is to comply with *Pt 4, Ch 10, 7.6 Inertia and dimensions of stiffeners*.

7.10 Docking brackets on bottom centreline girder

7.10.1 Stiffened docking brackets are to be fitted on both sides of the bottom centreline girder, midway between transverses, and are to be connected to a suitable bottom shell longitudinal. The bracket on one side is to be connected to the face plate of the girder but the other may be stopped at a suitable horizontal stiffener.

7.10.2 Additional vertical stiffeners may be required on the bottom panels of the girder to resist docking pressures.

7.11 Lateral stability of primary members

7.11.1 Tripping brackets are generally to be fitted close to the toes of end brackets, in way of cross-ties and elsewhere, so that the spacing between brackets does not exceed the lesser of 4,5 m or 15 times the width of the face plate (20 times in the case of deck transverses). Arrangements in way of the intersections of primary members are to be such as to prevent tripping. A closer spacing of brackets may be required to be adopted with asymmetrical face plates.

7.11.2 To maintain continuity of strength, substantial horizontal and vertical brackets are to be fitted to transverses or stringers at ends of cross-ties. Horizontal brackets are to be aligned with the cross-tie face plates, and vertical end brackets are to be aligned with the cross-tie web.

7.11.3 Tripping brackets are to be connected to the face plate of the bottom transverses. Elsewhere, other than for docking girders, the bracket is to be connected to the face plate whenever the unsupported width of the latter exceeds 150 mm. Where the width of symmetrically placed face plates exceeds 400 mm, a small bracket is to be fitted opposite, and in line with, the tripping bracket. Equivalent support arrangements are to be provided for cross-tie face plates. Particular attention is to be paid to the support of continuous face plates in way of the radius at toes of brackets.

7.11.4 Wide face plates may require additional support between brackets.

7.11.5 In the fore peak tank, if the angle to the normal of the shell plating and the vertical webs exceeds 20° , double tripping brackets are to be fitted to the web at about midspan, but in no case greater than 3,0 m apart.

7.12 Openings in web plating

7.12.1 Where openings are cut in the webs of primary supporting members, the greatest dimension of the opening is not to exceed 20 per cent of the web depth. The opening is to be located so that the edges are not less than 40 per cent of the web depth from the face, and are equidistant from the corners of notches for frames or stiffeners. Openings are to be suitably framed where required.

7.12.2 Lightening holes are not to be cut in horizontal girders on the ship's side and longitudinal bulkheads, in symmetrical webs nor in side transverses and vertical webs in way of cross-ties and their end connections.

7.12.3 Holes cut in primary longitudinal members within $0,1D$ of the deck and bottom are, in general, to be reinforced as required by *Pt 4, Ch 9, 4.10 Deck openings*. Access holes may be cut in deep transverses and girders with suitable compensation to provide satisfactory resistance to deflection and shear buckling in the web.

7.12.4 All holes are to have smooth edges and are to be kept well clear of notches and the toes of brackets.

7.12.5 Small air and drain holes cut in primary members are to be kept clear of the toes of brackets and are to be well rounded with smooth edges. Where holes are cut in primary longitudinal members of higher tensile steel, they are to be elliptical or equivalent to minimize stress concentration.

7.12.6 Where holes are cut for heating coils, the lower edge of the hole is to be not less than 100 mm from the inside of the shell plating. Where large notches are cut in the transverses for the passage of longitudinal framing, adjacent to openings for heating coils, the longitudinal notches are to be collared. Examination of the buckling strength of the web plate panel between notches for longitudinals may be required.

7.13 Brackets connecting primary members

7.13.1 The requirements of *Pt 4, Ch 9, 10.13 Brackets connecting primary members* are also applicable to small conventional single hull tankers.

7.14 Arrangements at intersections of continuous secondary and primary members

7.14.1 For details and connections of collars, see *Pt 3, Ch 10, 5.2 Arrangements at intersections of continuous secondary and primary members*.

Section

- 1 **General**
 - 2 **Materials and protection**
 - 3 **Longitudinal strength**
 - 4 **Hull envelope plating**
 - 5 **Hull framing**
 - 6 **Double bottom construction**
 - 7 **Longitudinal bulkheads**
 - 8 **Transverse bulkheads**
 - 9 **Primary structure in wing tanks**
 - 10 **Direct calculations**
 - 11 **Forecastles**
 - 12 **Single pass loading**
-

■ *Section 1*
General

1.1 Application

1.1.1 This Chapter applies to the arrangements and scantlings within the cargo region of sea-going ore carriers, intended for the carriage of ore in centre holds.

1.1.2 The requirements of *Pt 4, Ch 9 Double Hull Oil Tankers* are to be applied to ore carriers, except as required by the provisions of this Chapter.

1.1.3 The scantlings of structural items may be determined by direct calculation. Where the length of the ship exceeds 150 m, the scantlings of the primary supporting structure and the fatigue performance of structural details are to be assessed in accordance with the relevant ShipRight procedures, see *Pt 4, Ch 11, 1.3 Class notation 1.3.3*. In such cases, the calculations are to be submitted for approval.

1.1.4 The additional requirements for ore-carriers for the alternate carriage of oil cargo and dry bulk cargo are given in *Pt 4, Ch 9, 11 Ships for alternate carriage of oil cargo and dry bulk cargo*.

1.1.5 Ore carriers with a deadweight greater than 200 000 tonnes are to comply with the requirements of Section 12 for single pass loading.

1.2 Structural configuration and ship arrangement

1.2.1 The requirements contained in the Chapter apply to single deck ships with machinery aft, having two longitudinal bulkheads and a double bottom throughout the centre hold. A typical cross-section is indicated in *Figure 11.1.1 Typical cross-section*.

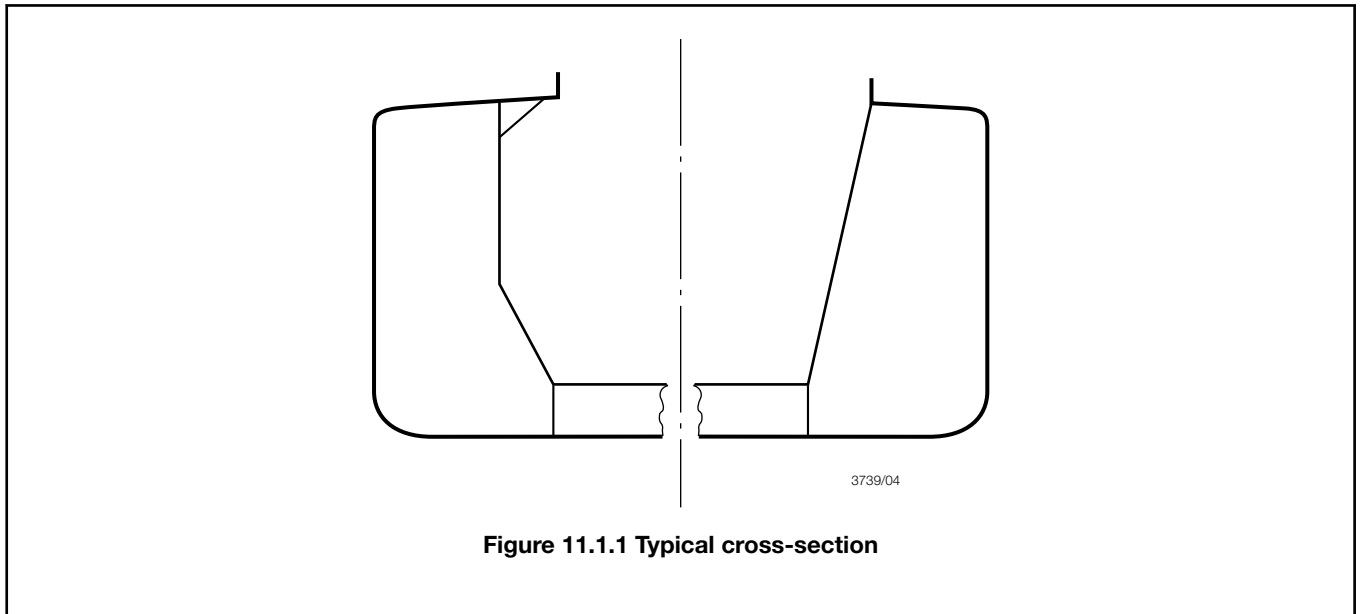

1.2.2 The bottom, and the deck outside the line of ore hatchways, are to be framed longitudinally within the cargo region. The side shell and longitudinal bulkheads are generally to be framed longitudinally where the length of the ship exceeds 150 m, but alternative proposals will be specially considered. Inside the line of openings, the deck is to be transversely framed.

1.3 Class notation

1.3.1 Sea-going ships complying with the requirements of this Chapter and other relevant Rule requirements for the draught required will be eligible to be classed **100A1 ore carrier, ESP**.

1.3.2 The notation **ESP** serves to identify the ship as being subject to an Enhanced Survey Programme as detailed in *Pt 1, Ch 3, 3 Intermediate Surveys - Hull and machinery requirements* and *Pt 1, Ch 3, 6 Special Survey - Bulk carriers - Hull requirements*, see also *Pt 1, Ch 2, 2.3 Class notations (hull) 2.3.12*.

1.3.3 The ShipRight 'Structural Design Assessment' (SDA), 'Fatigue Design Assessment' (FDA) and 'Construction Monitoring' (CM) procedures are mandatory for ships with length, L , exceeding 150 m and for ships of abnormal hull-form, or of unusual structural configuration or complexity, see *Pt 4, Ch 11, 10 Direct calculations*.

1.3.4 The Regulations for classification and the assignment of class notations are given in *Pt 1, Ch 2, 2 Character of classification and class notations*.

1.4 Symbols and definitions

1.4.1 The following symbols and definitions are applicable to this Chapter unless otherwise stated:

L, B, D, T as defined in *Pt 3, Ch 1, 6 Definitions*.

b = the width of plating supported by the primary member, in metres or mm

h = the load head, in metres, applied to the item under consideration

k = higher tensile steel factor. For the determination of this factor, see *Pt 3, Ch 2, 1 Materials of construction*. For mild steel k may be taken as 1,0

l_e = effective length of primary or secondary member, in metres, see *Pt 3, Ch 3, 3 Structural idealisation*.

s = spacing, in mm, of secondary members

Z = the section modulus, in cm^3 , of the primary or secondary member, in association with an effective width of attached plating determined in accordance with *Pt 3, Ch 3, 3 Structural idealisation*.

1.4.2 The expression 'primary member' as used in this Chapter is defined as a girder, transverse, vertical web, stringer, cross-tie, buttress or double bottom floor. 'Secondary members' are supporting members other than primary members.

■ *Section 2*
Materials and protection

2.1 Materials and grades of steel

2.1.1 Materials, grades of steel and protection of materials are to comply with the requirements of *Pt 3, Ch 2 Materials*, and the *Rules for the Manufacture, Testing and Certification of Materials, July 2015*.

2.2 Corrosion protection coating for salt-water ballast spaces

2.2.1 The requirements of *Pt 3, Ch 2, 3.6 Application of coatings and alternative means of protection* and *Ch 15 Corrosion Prevention* of the Rules for Materials are to be complied with.

■ *Section 3*
Longitudinal strength

3.1 General

3.1.1 The longitudinal strength standard is to comply with the relevant requirements of *Pt 3, Ch 4 Longitudinal Strength*.

3.1.2 For ships of length ≥ 150 m, with holds where any part of the longitudinal bulkhead is located within $B/5$ or 11,5 m, whichever is less, inboard from the ship's side at right angles to the centreline at the assigned summer load line, the requirements of *Pt 4, Ch 7, 3 Longitudinal strength* are also to be applied.

■ *Section 4*
Hull envelope plating

4.1 General

4.1.1 The requirements for hull envelope plating as given for oil tankers in *Pt 4, Ch 9, 4 Hull envelope plating* are to be applied, except as provided for in this Section.

4.2 Deck plating in way of ore hatchways

4.2.1 The arrangement and scantlings of deck plating inside the line of ore hatchways and in way of ore hatchway corners are to be in accordance with the requirements for bulk carriers given in *Pt 4, Ch 7, 4 Deck structure*.

4.3 Hatchways

4.3.1 The scantlings of the cargo hold hatch covers are to comply with *Pt 3, Ch 11, 2 Steel hatch covers* and *Pt 4, Ch 7, 12 Steel hatch covers*.

4.4 Hatch coamings

4.4.1 The height and construction of hatch coamings are to comply with *Pt 4, Ch 7, 13 Hatch coamings*.

4.4.2 Wire rope grooving in way of cargo hold openings is to be prevented by fitting suitable protection, such as halfround bars, on the hatch side girders (upper portion of top-side tank plates), hatch end beams, and the upper portion of hatch coamings.

■ Section 5 Hull framing

5.1 General

5.1.1 The framing requirements given for oil tankers in *Pt 4, Ch 9, 5 Hull framing* are to be applied, except as provided for in this Section.

5.1.2 Lateral buckling of longitudinal and transverse ordinary stiffeners is to be assessed in the following areas in association with a factor of safety of not less than 1,15 (allowable utilisation factor to be reduced by at least $1/1,15 = 0,87$). Details are to be submitted:

- hatchway coaming;
- inner bottom;
- sloped stiffened panel of topside tanks (if any);
- longitudinal bulkhead;
- top stool and bottom stool of transverse bulkhead (if any) and
- stiffened transverse bulkhead (if any).

5.2 Symbols

5.2.1 The symbols used in this Section are defined as follows:

h = load height, in metres, on the weather deck for primary and secondary members between ore hatchways

= 1,8 for secondary members forward of $0,075L$ from F.P.

= $4,2 + 2,04E$ for primary members forward of $0,075L$ from F.P.

= 1,5 between $0,075L$ and $0,12L$ from F.P.

= $1,2 + 2,04E$ elsewhere

= where $E = \frac{0,0914 + 0,003L}{D - T} - 0,15$ but not to be greater than 0,147

K_1 = 1,6 in the forward $0,12L$

= 1,06 elsewhere

K_2 = 0,00054 in the forward $0,075L$

= 0,00033 elsewhere.

5.2.2 Other symbols are defined in *Pt 4, Ch 11, 1.4 Symbols and definitions*.

5.3 Bottom longitudinals in double bottom tanks

5.3.1 The section modulus of bottom longitudinals in the double bottom in the centre hold is to satisfy the requirements of *Table 1.6.2 (b) Shell framing (longitudinal)* in Chapter 1.

5.3.2 In general, the span of longitudinals in the double bottom in the centre hold is not to exceed 2,5 m or $0,01L$, whichever is the greater, and the span in the wing tanks is not to exceed the greater of 3,6 m or $0,02L$.

5.4 Deck structure in way of centre hold

5.4.1 Where the hatch coamings are situated inboard of the longitudinal bulkhead, the deck between the two is to be fitted with suitably supported longitudinals complying with *Pt 4, Ch 9, 5 Hull framing*.

5.5 Primary and secondary members inside line of ore hatchways

5.5.1 The section modulus of secondary members between hatches is to be not less than:

$$Z = k (K_1 TD + K_2 hB I_e^2 s) \text{ cm}^3$$

but need not exceed twice the value given by the second term within the brackets in the formula.

5.5.2 The section modulus of primary members between hatches is to be not less than:

$$Z = 5,46kbh I_e^2 \text{ cm}^3$$

Forward of 0,075L from the forward perpendicular, the depth of the primary member is to be not less than twice that of the secondary member supported.

5.5.3 Particular attention is to be paid to the scarfing of deck beams into the structure outside the line of openings. Substantial brackets or equivalent arrangements are to be provided.

■ Section 6 Double bottom construction

6.1 General

6.1.1 The double bottom depth and scantlings are to be as required by *Pt 4, Ch 7, 8 Double bottom structure* for the double bottom structure of a bulk carrier to which the notation 'strengthened for heavy cargoes' is to be assigned. However, where *Pt 4, Ch 11, 3.1 General 3.1.2* is not applicable, the requirements of *Pt 4, Ch 7, 8.8 Allowable hold loading in the flooded condition* need not be applied. The required depth of double bottom and scantlings of double bottom structure are to be verified by direct calculation. The calculation is to be submitted.

6.1.2 Where the proposed depth of double bottom exceeds 1,5 times the Rule minimum depth given in *Pt 4, Ch 1, 8 Double bottom structure*, the scantlings of the floors and girders may be required to be increased to ensure adequate resistance to buckling.

6.1.3 The thickness of inner bottom plating in the cargo hold is to be not less than required by *Pt 4, Ch 7, 8 Double bottom structure* for ships having the notation '**strengthened for heavy cargoes**'.

6.1.4 For all vessels intended to be unloaded by grabs, the thickness of inner bottom plating is to meet the requirements of *Pt 3, Ch 9, 8.2 Inner bottom plating 8.2.1* for a maximum design grab weight specified and recorded in the Loading Manual. For vessels of deadweight >200 000 tonnes, the design grab weight is not to be less than 25 tonnes.

6.1.5 Where the requirements of *Pt 4, Ch 11, 6.1 General 6.1.4* are met the descriptive note '**holds suitable for unloading by grabs**' may be employed. Where the design grab weight is 25 tonnes or more the notation '**strengthened for regular discharge by heavy grabs**' may be assigned.

6.2 Arrangement

6.2.1 In way of the cargo hold a centreline girder is to be fitted and side girders spaced not more than 3,8 m apart are generally to be arranged in way of transverse bulkheads. The side girders are to extend at least to the first plate floor adjacent to the bulkhead each side. The outboard side girder is to be continuous, forming the lower part of the longitudinal bulkhead.

6.2.2 Plate floors are to be fitted in line with each transverse in the wing tanks and in way of transverse bulkhead stools. Additional floors are to be so arranged that the spacing of floors does not exceed 2,5 m or 0,01L, whichever is the greater.

6.2.3 Attention is to be given to structural continuity and alignment between double bottom structure and transverses in wing tanks, see also *Pt 4, Ch 11, 9.2 Scarfing of double bottom*.

6.2.4 Alternative arrangements will be considered on the basis of the results of direct calculations.

■ Section 7
Longitudinal bulkheads

7.1 General

7.1.1 The requirements for longitudinal oiltight bulkheads given in *Pt 4, Ch 9, 6 Inner hull, inner bottom and longitudinal oiltight bulkheads* and *Pt 4, Ch 9, 9 Primary members supporting longitudinal framing* are to be applied, together with the additional requirements of this Section.

7.1.2 Longitudinal bulkhead scantlings are to be additionally assessed against ore loading in accordance with *Table 11.7.1 Longitudinal and transverse bulkhead scantlings for ore loading*.

Table 11.7.1 Longitudinal and transverse bulkhead scantlings for ore loading

Item	Longitudinal and transverse bulkhead
Plate thickness including corrugations (mm)	$t = 0,004sf \sqrt{\frac{K_c H k}{C}} + 3,5 \text{ mm}$
Modulus of rolled and built stiffeners, and symmetrical corrugations (cm ³)	$Z = \frac{s k K_c H l_e^2}{22C \gamma (\omega_1 + \omega_2 + 2)} \text{ cm}^3$
Symbols	
<p>= s, S, k, l as defined in <i>Pt 4, Ch 1, 1.5 Symbols and definitions 1.5.1</i></p> <p>f = 1,1 – s/2500S but not to be taken greater than 1,0</p> <p>l_e = effective length of stiffening member, in metres, and for bulkhead stiffeners, to be taken as $l - e_1 - e_2$</p> <p>γ = 1,4 for rolled or built sections and double plate bulkheads</p> <p>= 1,6 for flat bars</p> <p>= 1,1 for symmetrical corrugations of deep tank bulkheads</p> <p>= 1,0 for symmetrical corrugations of watertight bulkheads</p> <p>ω, e = as defined in <i>Table 1.9.3 Bulkhead end constraint factors</i> in Chapter 1, see also <i>Figure 1.9.1 End connections</i>. Where applicable the value of M_2 is to be taken as</p> $= \frac{K_c H s l^2}{22C}$ <p>K_c = ore pressure coefficient, to be taken as $\cos^2 \alpha + (1 - \sin \psi) \sin^2 \alpha$ for inner side (hopper tank, transverse and longitudinal bulkheads, lower stool, vertical upper stool, etc.), and where:</p> <p>K_c = 0 for top side tank, upper deck and sloped upper stool</p> <p>α = angle, in degrees, between panel considered and the horizontal plane</p> <p>ψ = assumed angle of repose, in degrees, of bulk cargo (considered drained and removed); in the absence of more precise evaluation to be taken as $\psi = 35^\circ$ for iron ore</p> <p>H = height, from position under consideration to deck at side amidships, in metres</p> <p>C = stowage rate, in m³/tonne, as defined in <i>Pt 3, Ch 3, 5.2 Symbols</i>. For vessels where <i>Pt 4, Ch 11, 1.1 Application 1.1.5</i> is applicable, C is to include the cargo overshoot specified in <i>Pt 4, Ch 11, 12.4 Cargo loading conditions for design assessment 12.4.1</i></p>	

7.1.3 Longitudinal bulkheads on ore carriers are to be plane with rolled or fabricated longitudinal stiffeners. The bulkhead may be sloped to form a hopper shape in the lower part of the hold or over its full depth.

7.1.4 Where the upper part of the bulkhead is vertical and the lower part sloped to form a hopper shape, the thickness of the bulkhead plating in way of the knuckle may be required to be increased to resist transverse compressive buckling stresses. The knuckle is to be arranged in way of a longitudinal.

7.1.5 The thickness of the lowest strake of sloped bulkhead plating is also to comply with inner bottom requirements as given in *Pt 4, Ch 11, 6.1 General 6.1.3*. Where this provision results in an increase in thickness, the latter may be gradually tapered above the lowest strake to the required longitudinal bulkhead thickness at the position of the knuckle, or at a point one third of the depth of the bulkhead above the inner bottom, whichever is the lower.

■ *Section 8* **Transverse bulkheads**

8.1 General

8.1.1 Where the form of construction used for transverse bulkheads in wing tanks is different from that used in centre holds, arrangements are to be made to ensure continuity of transverse strength through the longitudinal bulkhead.

8.2 Transverse watertight bulkheads in wing tanks

8.2.1 The requirements for transverse bulkhead plating, stiffening and primary structure given in *Pt 4, Ch 1, 9 Bulkheads* for deep tank bulkheads are to be applied.

8.3 Transverse watertight bulkheads in centre holds

8.3.1 Scantlings are to comply with *Pt 4, Ch 1, 9 Bulkheads* and assessed against ore loading in accordance with *Table 11.7.1 Longitudinal and transverse bulkhead scantlings for ore loading*. Transverse corrugated bulkhead scantlings may be determined by direct calculations but are not to be less than required by the watertight bulkhead requirements of *Pt 4, Ch 1, 9 Bulkheads*.

8.3.2 For ships where the requirements of *Pt 4, Ch 11, 3.1 General 3.1.2* are applicable, the requirements for transverse hold bulkheads given for the carriage of dry bulk cargoes in *Pt 4, Ch 7, 10 Bulkheads* are also to be applied.

8.3.3 In general, the bulkheads are to have stiffening or corrugations arranged vertically, supported by top and bottom end stools. Alternative arrangements will, however, be considered.

8.3.4 Where inner bottom plating is increased as required by *Pt 4, Ch 11, 6.1 General 6.1.4*, the lower part of the transverse bulkhead should also be increased in accordance with *Pt 3, Ch 9, 8.4 Transverse bulkhead plating 8.4.1*.

8.4 Non-watertight bulkheads

8.4.1 Non-watertight bulkheads in wing tanks are to comply with the requirements given in *Pt 4, Ch 9, 8 Non-oiltight bulkheads* and *Pt 4, Ch 9, 9.8 Primary members supporting non-oiltight bulkheads*.

8.4.2 The bulkhead plating is to be suitably reinforced in way of double bottom scarfing arrangements and the ends of centre hold deck transverses. Openings in wing tank bulkheads are to be kept clear of these areas.

■ *Section 9* **Primary structure in wing tanks**

9.1 General

9.1.1 The primary structure in the wing tanks is to comply with the requirements given in *Pt 4, Ch 9, 9 Primary members supporting longitudinal framing*.

9.2 Scarfing of double bottom

9.2.1 The inner bottom plating is to be extended into the wing tank in the form of a horizontal diaphragm, arranged to ensure a smooth structural transition in way of transverse primary members and to maintain longitudinal continuity. The diaphragms are to be of sufficient width to provide effective scarfing of the inner bottom into the wing tank structure.

9.2.2 Floors intermediate between transverses are to be backed in the wing tanks by substantial vertical brackets extending transversely over at least three bottom longitudinal spaces and vertically to a sufficient height above the horizontal diaphragms to provide effective support for the double bottom structure.

■ *Section 10*
Direct calculations

10.1 Application

10.1.1 Direct calculations are to be employed in the derivation of scantlings where required by the preceding Sections of this Chapter or by related provisions included in *Pt 3 Ship Structures (General)*.

10.1.2 Direct calculation methods are also generally to be used where additional calculations are required by the Rules in respect of unusual arrangements.

10.1.3 For complex structural arrangements, e.g. a double plate transverse bulkhead with stool in a centre hold, associated with plane wing tank bulkheads supported by stringers and buttresses, an investigation of bottom primary structure over a full cargo hold length and three-dimensional analysis of the transverse bulkhead structure will generally be required, taking account of applied longitudinal hull bending effects.

10.1.4 The cross-deck structure is to be verified as being capable of supporting transverse compressive stresses resulting from lightship weight, deadweight, hydrostatic and wave loads. For ore carriers that are designed to operate with an asymmetrical loading condition, or large ore carriers with $B \geq 40$ m or $b/w \geq 2,2$, the wave loads should take account of hydrodynamic torque in an oblique sea. The cross-deck structure is to comprise the hatch coamings and beams, the plating and attached stiffeners and the upper stool. Non-corrugated bulkhead plating may also be included

= where

B = moulded breadth, in metres

b = breadth of the deck hatch openings, in metres

w = width of the cross-deck strip between hatchways, in metres.

10.2 Procedures

10.2.1 For details of Lloyd's Register's direct calculation procedures, see *Pt 3, Ch 1, 2 Direct calculations*. For requirements concerning use of other calculation procedures, see *Pt 3, Ch 1, 3 Equivalentents*.

10.2.2 Where appropriate to the structural configuration, the direct calculation procedures for tanker primary structure, see *Pt 4, Ch 9, 14 Direct calculations*, will be adapted for application to ore carriers.

■ *Section 11*
Forecastles

11.1 General

11.1.1 A forecastle is to be fitted in accordance with the requirements of *Pt 4, Ch 7, 14 Forecastles*.

■ Section 12 Single pass loading

12.1 Scope and application

12.1.1 The requirements of this Section are to be applied to all ore carriers with a deadweight greater than 200 000 tonnes. The requirements are for single pass loading where the maximum permissible cargo intake per cargo hold may be loaded in a single loading pour.

12.2 Information required

12.2.1 In addition to the plans required for submission by *Pt 3, Ch 1, 5.2 Plans and supporting calculations* and as detailed in the applicable Chapters, the following information is also to be submitted:

- (a) Maximum permissible cargo in each cargo hold.
- (b) Cargo mass curves for a single and adjacent hold loadings taking into account the cargo overshoot defined in *Pt 4, Ch 11, 12.4 Cargo loading conditions for design assessment 12.4.1*.
- (c) One or more cargo loading sequences intended for single pass loading, see *Pt 4, Ch 11, 12.2 Information required 12.2.2*.
- (d) Details of ballast and deballast piping arrangements and pumping capacity.
- (e) Specification of loading computer.

12.2.2 The cargo loading sequences as required by *Pt 4, Ch 11, 12.2 Information required 12.2.1* are to include the following:

- (a) Start and end times of each cargo pour and the intended loading rate.
- (b) Start and end times of each deballasting operation and the intended discharge rate.
- (c) Intermediate points (in time) during pours and between pours. In general, the interval between intermediate points is not to be greater than 1 hour.
- (d) The ship's loading condition, including the ship's draughts at the fore and aft perpendiculars, amount of cargo in each hold and amount of ballast in each tank, and the still water bending moments and shear forces, are to be provided for each point (in time) of the loading operation specified in *Pt 4, Ch 11, 12.2 Information required 12.2.2, Pt 4, Ch 11, 12.2 Information required 12.2.2 and Pt 4, Ch 11, 12.2 Information required 12.2.2*.

12.3 Definitions

12.3.1 **Pour.** A pour is defined by the start and finish of loading of a cargo hold. A pour finishes when the loading equipment changes position to a new cargo hold.

12.3.2 **Overshooting.** Overshooting is to be taken as the consequence of mistiming the loading of cargo, resulting in cargo overloading.

12.4 Cargo loading conditions for design assessment

12.4.1 For the purpose of the design assessment, the following conditions are assumed:

- (a) Cargo loading and deballasting operations are coordinated, with the deballast capacity and arrangement of the vessel designed to accommodate the specified loading sequences.
- (b) The cargo is distributed symmetrically in a hold space.
- (c) Deballasting is carried out for each pair of symmetrical port and starboard tanks simultaneously, so that each pair of symmetrical port and starboard ballast tanks contain equal amounts of water ballast throughout deballasting operations.
- (d) To improve deballasting and stripping, the trim of the ship is to be, in general, by the stern throughout the cargo loading operation.
- (e) A cargo overshoot per cargo hold is taken as 10 per cent of the maximum permissible hold cargo mass or 3000 tonnes, whichever is the lesser, but not less than 5 per cent of the maximum permissible hold cargo weight, in any case. A higher cargo overshoot may be specially considered.
- (f) Loading more than one cargo hold simultaneously in a single pass, i.e. simultaneous filling of two or more holds, will be specially considered. The specific loading conditions are to be submitted for appraisal in addition to the condition(s) for standard single-pass loading.

12.5 Design assessment

12.5.1 The following criteria are to be complied with in all cargo loading sequences:

- (a) Still water bending moment and shear force are within the allowable limits.
- (b) Single hold loading is within the allowable hold mass curve.
- (c) Two adjacent holds loading are within the allowable hold mass curve.

12.5.2 Arrangements and scantlings of local stiffeners and plating within the cargo hold region are to comply with *Pt 4, Ch 11, 1 General* to *Pt 4, Ch 11, 11 Forecastles* with consideration of the maximum permissible cargo mass per hold in the loading manual and the cargo overshoot specified in *Pt 4, Ch 11, 12.4 Cargo loading conditions for design assessment 12.4.1*.

12.5.3 The primary structure and plating within the cargo hold region are to be assessed in accordance with the *ShipRight SDA Procedure for Ore Carriers*.

12.6 Ballast arrangements

12.6.1 The deballasting capacity of the vessel, including arrangement of ballast tanks, pumps and relevant piping system, is to be sufficient for the loading operations as agreed in the approved loading plan.

12.6.2 A smaller diameter stripping system with separate main and branch lines may need to be provided in order to achieve the required deballasting capacity.

12.7 Loading manual

12.7.1 All loading sequences of single pass loading, maximum loading rates and ballast pumping details are to be submitted for approval and included in the Loading Manual. Loading conditions at intermediate points as described in *Pt 4, Ch 11, 12.2 Information required 12.2.2* need not be included in the Loading Manual.

12.8 Loading computer

12.8.1 The ship is to be installed with sensors for remote measurement of water ballast, fuel oil and ship's draughts.

12.8.2 In addition, it is recommended that an interface with the onboard loading computer, connecting to the installed sensors detailed in *Pt 4, Ch 11, 12.8 Loading computer 12.8.1*, is to be provided to check the ship's condition during loading and unloading.

Section

-
- 1 **General**
 - 2 **Longitudinal strength**
 - 3 **Deck structure**
 - 4 **Shell envelope plating**
 - 5 **Shell envelope framing**
 - 6 **Bottom structure**
 - 7 **Bottom strengthening for operating aground**
 - 8 **Spoil space and well structure**
 - 9 **Watertight bulkheads**
 - 10 **Exposed casings**
 - 11 **Dredging machinery seats and dredging gear**
 - 12 **Ladder wells**
 - 13 **Fenders**
 - 14 **Rudders**
 - 15 **Spoil space weirs and overflows**
 - 16 **Scuppers and sanitary discharges and side scuttles**
 - 17 **Split hopper dredgers and barges**
 - 18 **Direct calculations**
-

■ *Section 1*
General

1.1 Application

1.1.1 This Chapter applies, in general, to manned or unmanned self-propelled or non-self-propelled ships defined as follows:

- (a) Dredgers designed to operate wholly or generally for the purpose of raising spoil such as mud, silt, gravel, clay, sand or similar substances, general rubbish or ore, minerals, etc. for the bed of the sea, rivers, lakes, canals or harbours, etc. The dredged material may be placed in suitably designed holds or similar spaces within the ship.
- (b) Hopper dredgers, designed to raise spoil, as described in *Pt 4, Ch 12, 1.1 Application 1.1.1*, and so arranged that the dredged material may be placed in one or more hoppers within the ship. For the purpose of this definition, a hopper is a hold or other space designed to carry dredged spoil and also arranged to enable such spoil to be discharged through doors or valves in the bottom of the ship. Spaces arranged to be unloaded by means of conveyor belts, suction pipes or similar gear are not to be regarded as hoppers unless adequate bottom doors or valves are also fitted.
- (c) Split hopper dredgers, which are designed similarly to that described in *Pt 4, Ch 12, 1.1 Application 1.1.1* but arranged such that the spoil is discharged through the bottom of the ship by means of the split hull being separated using hinges and actuating devices.
- (d) Reclamation craft, reclamation ships, etc. which work in a manner similar to dredgers but draw their spoil from dredging craft and discharge it ashore.
- (e) Hopper barges designed to carry spoil or dredged material in hoppers within the ship. For the definition of a hopper, see *Pt 4, Ch 12, 1.1 Application 1.1.1*.

(f) Split hopper barges, which are designed similarly to that described in *Pt 4, Ch 12, 1.1 Application 1.1.1* but arranged such that the spoil is discharged through the bottom of the ship by means of the split hull being separated using hinges and actuating devices.

1.1.2 The scantlings and arrangements are to be as required by *Pt 4, Ch 1 General Cargo Ships*, except as otherwise specified in this Chapter.

1.1.3 Where bottom dump doors or valves are fitted, hatch covers are not required. Proposals for the omission of hatch covers where bottom dump doors or valves are not fitted will be specially considered.

1.1.4 Ships which have their machinery placed on a shallow raft, rather than within a hull, will have their scantlings specially considered. Dredgers which resemble drilling rigs, or similar offshore structures, in their design or mode of operation will be considered under the Rules for such structures.

1.1.5 Ships of unusual form or proportions, or intended for unusual dredging methods, will receive individual consideration on the basis of the general standards of the Rules.

1.1.6 The requirements provide for transverse and longitudinal framing of the structure. In general, the midship region scantlings are to extend over the full length of hoppers and holds. The extent is to be not less than 0,4L amidships, and may need to be increased if the design and loading conditions of a particular ship result in its maximum bending moment occurring other than at amidships.

1.2 Stability

1.2.1 Attention is drawn to the thixotropic properties of certain types of dredged material which, as a result of the ship's motions, can cause the spoil to shift within spoil spaces, resulting in undesirable changes in trim or angles of heel. This can be particularly dangerous in ships with closed top spaces.

1.3 Class notations

1.3.1 In general, ships complying with the requirements of this Chapter will be eligible for one of the following classes:

- (a) **100A1 dredger**. This class will be assigned to ships as defined in *Pt 4, Ch 12, 1.1 Application 1.1.1*.
- (b) **100A1 hopper dredger**. This class will be assigned to ships as defined in *Pt 4, Ch 12, 1.1 Application 1.1.1*.
- (c) **100A1 split hopper dredger**. This class will be assigned to ships as defined in *Pt 4, Ch 12, 1.1 Application 1.1.1*.
- (d) **100A1 reclamation craft**. This class will be assigned to ships as defined in *Pt 4, Ch 12, 1.1 Application 1.1.1*.
- (e) **100A1 hopper barge**. This class will be assigned to ships as defined in *Pt 4, Ch 12, 1.1 Application 1.1.1*.
- (f) **100A1 split hopper barge**. This class will be assigned to ships as defined in *Pt 4, Ch 12, 1.1 Application 1.1.1*.

1.3.2 The class notations will be assigned to ships based on the following:

- (a) The class notations in *Pt 4, Ch 12, 1.3 Class notations 1.3.1* will be assigned to ships which are intended to make unrestricted sea-going voyages, either as part of their work or while transferring from one work area to another as part of their normal operations and have also been designed to perform dredging operations in defined dredging service areas.
- (b) Where dredger types listed in *Pt 4, Ch 12, 1.3 Class notations 1.3.1*, *Pt 4, Ch 12, 1.3 Class notations 1.3.1* and *Pt 4, Ch 12, 1.3 Class notations 1.3.1* perform dredging operations at reduced freeboards, resulting in a dredging draught (T_m) greater than the summer draught and without a dredging service area restriction, the class notation will be extended as follows: **'dredging draught T_m of ... metres in sea states with $H_s < \dots$ metres'** and will be subject to special requirements of National Authorities, see *Pt 4, Ch 12, 1.6 Requirements for dredgers operating at reduced freeboards 1.6.1*.
- (c) Where dredger types listed in *Pt 4, Ch 12, 1.3 Class notations 1.3.1*, *Pt 4, Ch 12, 1.3 Class notations 1.3.1* and *Pt 4, Ch 12, 1.3 Class notations 1.3.1* perform dredging operations at reduced freeboards, resulting in a dredging draught (T_m) greater than the summer draught but with a dredging service area limited to within 21 nautical miles from shore, the class notation will be extended as follows: **'dredging within 21 miles from shore at a dredging draught T_m of ... metres'** and will be subject to special requirements of National Authorities, see *Pt 4, Ch 12, 1.6 Requirements for dredgers operating at reduced freeboards 1.6.1* and *Pt 4, Ch 12, 1.6 Requirements for dredgers operating at reduced freeboards 1.6.2*.
- (d) Where requested, the assignment of more than one dredging draught may be considered, i.e. **'dredging at draught $T_{m1} \dots$ '** and **'dredging at draught $T_{m2} \dots$ '**, etc. provided agreement is obtained from the National Authorities and the applicable requirements of this Chapter are complied with.

1.3.3 Ships intended to be operated only in suitable areas or conditions which have been agreed by the Committee, as defined in *Pt 1, Ch 2, 2.3 Class notations (hull) 2.3.6*, *Pt 1, Ch 2, 2.3 Class notations (hull) 2.3.7*, *Pt 1, Ch 2, 2.3 Class notations (hull) 2.3.8* and *Pt 1, Ch 2, 2.3 Class notations (hull) 2.3.10*, will receive individual consideration on the basis of the Rules with

respect to the environmental conditions agreed for the design basis and approval. In particular, dredgers complying with the requirements of this Chapter and *Pt 3, Ch 13, 7 Equipment* for the reduced equipment requirements, will be eligible to be classed:

(a) **A1 dredger protected waters service**, see *Pt 1, Ch 2, 2.3 Class notations (hull) 2.3.6*, or

100A1 dredger with service restriction notation.

whichever is applicable. Hopper dredgers, split hopper dredgers, reclamation craft, hopper barges and split hopper barges would be considered similarly.

1.3.4 Where a ship complying with the requirements of this Chapter has the bottom structure additionally strengthened for operating aground in accordance with *Pt 4, Ch 12, 7 Bottom strengthening for operating aground*, it will be eligible for the special feature notation 'bottom strengthened for operating aground'.

1.3.5 In addition to the above notations, an appropriate descriptive note may be entered in the *Register Book* indicating the type of dredging or reclamation craft (see *Pt 1, Ch 2, 2.6 Class notations (refrigerated cargo installations (RMC), controlled atmosphere (CA) systems and carriage of refrigerated containers (CRC)) 2.6.1*), e.g. 'trailing suction dredger', 'cutter suction dredger', 'bucket dredger', 'grab dredger', 'dipper dredger', 'self-discharging sand dredger', etc.

1.3.6 The Regulations for classification and assignment of class notations are given in *Pt 1, Ch 2 Classification Regulations* to which reference should be made.

1.4 Information required

1.4.1 In addition to the information and plans required by *Pt 3, Ch 1, 5 Information required* details of the following are to be submitted:

- Sections through hoppers, wells, pump-rooms and dredging machinery spaces.
- Hopper, hold and well bulkheads and associated weirs.
- Scarfing arrangements at hopper, hold and well ends.
- Hinges, actuating and locking arrangements, together with supporting structure, weld connection details and calculations of design forces for split hull separation devices.
- Deckhouse and deckhouse support structure.
- Outline arrangement and main scantlings of 'A' frames, gantries, positioning spuds, hopper doors and similar items, the strength and integrity of which directly affect the hull structure of the vessel. Support structure in way of 'A' frames, positioning spuds and other dredging structures. Seats of dredging machinery and pumps. If dredging equipment is stored during voyages, plans of any special arrangements for dismantling, storage and reassembly. Sufficient particulars of static and dynamic loading for these items are to accompany the details to enable verification of the strength and effectiveness of the supporting ship structure.
- A full set of stability data which is to be placed on board the ship, see *Pt 1, Ch 2, 3 Surveys - General*.
- Calculations of hull girder still water bending moment and shear force where applicable, see *Pt 4, Ch 12, 2.1 General 2.1.1*, for the proposed loading conditions, including densities of spoil. When the still water bending moment and block coefficient are being calculated, any water within spoil spaces should be regarded as added weight, whilst that in dredging ladder wells and spud wells should be regarded as lost buoyancy.

1.5 Symbols

1.5.1 The following symbols and definitions are applicable to this Chapter unless otherwise stated:

B = breadth, in metres, defined as the greatest moulded breadth excluding any localised bulge on the hull associated with the attachment or handling of the dredging gear

C_b = the moulded block coefficient at draught T but is to be taken as not less than 0,6. The block coefficient is to be determined using the length, L . Spoil spaces should be regarded as added weight, whilst dredging ladder wells and spud wells should be regarded as lost buoyancy

C_{bm} = the moulded block coefficient at the dredging draught T_m , but is to be taken as not less than 0,6. The block coefficient is to be determined using length, L . Spoil spaces should be regarded as added weight, whilst dredging ladder wells and spud wells should be regarded as lost buoyancy

D = moulded depth, in metres, to the uppermost continuous deck

L = Rule length, in metres, as defined in *Pt 3, Ch 1, 6 Definitions* for ships classed for unrestricted service. For ships classed **A1 protected waters service** where the load waterline is not required to be determined by the International Load Line Convention method, the length is to be measured on the deepest waterline at which the ship is designed to operate. On sea-going vessels with unusual stern arrangement, or with unusual bow arrangement associated with a dredging draught in excess of the summer load line draught, the length, L , will be specially considered

M_s = design still water bending moment, in kNm (tonne-f m), at draught, T , or less

\overline{M}_s = maximum permissible still water bending moment, in kNm (tonne-f m), at draught, T , or less

M_{sm} = design still water bending moment, in kNm (tonne-f m), under dredging conditions at draught, T_m

\overline{M}_{sm} = maximum permissible still water bending moment, in kNm (tonne-f m), under dredging conditions at draught, T_m

M_w = design hull vertical wave bending moment amidships, in kN m (tonne-f m), see *Pt 4, Ch 12, 2.4 Design vertical wave bending moments 2.4.1*

T = summer draught, in metres, as established by the method described in the International Load Line Convention, measured from top of keel amidships

T_m = maximum dredging draught, in metres, at which the ship is designed to operate. It is to be measured amidships from the top of keel and is to be taken not less than T , see *Pt 4, Ch 12, 15.1 General 15.1.4*

ρ = relative density (specific gravity) which, in general, is to be taken not less than 1,86, or as derived from the stowage rate of spoil. This stowage rate of dredged spoil is to be determined from the maximum spoil weight at dredging draught and volume of spoil space up to the sill of the uppermost overflow weir. The value used in the calculations of scantlings is to be clearly marked on the relevant plans

Hogging bending moments are positive.

1.5.2 For symbols not defined in this Chapter, see *Pt 4, Ch 1 General Cargo Ships*.

1.6 Requirements for dredgers operating at reduced freeboards

1.6.1 Requirements of IMO DR 68 *Guidelines for the Operation of Dredgers at Reduced Freeboards* are to be complied with.

1.6.2 The dredger is to be of a self discharging type and equipped with bottom valves. When the ship is operating at a reduced freeboard, i.e. 1/2 or 1/3 of its summer freeboard, the capacity of these bottom valves, or a part thereof, is to be sufficient to obtain the summer freeboard by discharging the appropriate amount of cargo within 8 minutes (IMO DR 68 refers).

1.6.3 Where the class notation '**dredging draft T_m of ... metres in sea states with $H_s < \dots$ metres**' is assigned, the Master is to be provided with suitable information on the actual situation of the sea conditions and the forecast in terms of significant wave heights.

■ Section 2 Longitudinal strength

2.1 General

2.1.1 Longitudinal strength calculations are to be made in accordance with the relevant requirements given in *Pt 3, Ch 4 Longitudinal Strength*, except as indicated in this Section.

2.2 Loading conditions

2.2.1 Details are to be submitted of the following loading conditions for examination of longitudinal strength:

- (a) Homogeneous load conditions (including details of densities of spoil) for both departure and arrival at draught, T , and maximum dredging draught, T_m , where this exceeds T , see also Pt 4, Ch 12, 15.1 General 15.1.4.
- (b) Part loaded conditions (including details of densities of spoil) and ballast conditions for both departure and arrival.
- (c) Any specified non-homogeneous load conditions.

2.2.2 If any dredging equipment has to be unshipped, lowered or otherwise specially arranged or stowed before the ship proceeds on a sea-going voyage, this fact is to be indicated on the longitudinal strength information required to be submitted and is also to be clearly stated in the final Loading Manual supplied to the ship.

2.2.3 For loading conditions, and any other preparations required to permit ships with a notation specifying some service limitation to undertake a sea-going voyage, either from port or building to service area or from one service area to another, see Pt 1, Ch 2, 1 Conditions for classification.

2.2.4 Where a ship is arranged with two spoil spaces account is to be taken in the calculation of the still water bending moment of either one of these spaces being empty, unless such loading is specifically precluded in the Loading Manual supplied to the ship.

2.2.5 The requirements of Pt 3, Ch 4, 8.3 Loading instrument regarding loading instruments are not applicable to dredging and reclamation craft.

2.3 Hull bending strength

2.3.1 Hull bending strength standards are to comply with the relevant requirements of Pt 3, Ch 4 Longitudinal Strength, taking account of the contents of Pt 4, Ch 12, 2.4 Design vertical wave bending moments and Pt 4, Ch 12, 2.5 Permissible still water bending moment for dredging conditions.

2.3.2 For split hopper dredgers or barges, due account is to be taken of the lateral forces and moments on each half hull which are exerted by the pressure of the spoil and dynamic wave loading, see Pt 4, Ch 12, 17.2 Hull bending strength.

2.4 Design vertical wave bending moments

2.4.1 The design vertical wave bending moment at amidships, M_w , is to be determined from Pt 3, Ch 4, 5.2 Design vertical wave bending moments with the ship service factor, f_1 , given in Table 12.2.1 Ship service factors f_1 and f_{wd} .

Table 12.2.1 Ship service factors f_1 and f_{wd}

Class Notation	f_1	f_{wd}
+ 100A1... , dredging draught T_m of ... metres in sea states with $H_s < \dots$ metres	1,00	f_{uds}
+100 A1... , dredging within 21 miles from shore at a dredging draught T_m of ... metres	0,75	0,60
+A1... , Protected waters service	0,65	0,35
Symbols		
$f_{uds} = 2,2H_s L^{-0,48}$, not to be taken less than 0,35 nor greater than 1 $H_s =$ significant wave height for the dredging operations at the considered dredging draught T_m		
Note The wave reduction factors may only be used for dredgers complying with the applicable requirements of Pt 4, Ch 12, 1.6 Requirements for dredgers operating at reduced freeboards 1.6.1.		

2.4.2 The design hull vertical wave bending moment at amidships for dredging conditions, M_{wd} , where draught T_m is greater than T , is given by the following expression:

$$M_{wd} = f_{wd} f_2 M_{wo}$$

where

M_{wo} is determined from Pt 3, Ch 4, 5.2 Design vertical wave bending moments, using C_{bm} in place of C_b

f_2 is given in Pt 3, Ch 4, 5.2 Design vertical wave bending moments

f_1 and f_{wd} are defined in Table 12.2.1 Ship service factors f_1 and f_{wd} .

2.5 Permissible still water bending moment for dredging conditions

2.5.1 The maximum permissible still water bending moment, \overline{M}_{sm} , for dredging conditions where draught T_m exceeds T is not to exceed:

$$|\overline{M}_{sm}| = |\overline{M}_s + f_1 f_2 M_{wo} - M_{wd}| \quad kNm(\text{tonne} - fm)$$

where M_{wd} is defined in Pt 4, Ch 12, 2.4 Design vertical wave bending moments 2.4.2.

Where applicable, the relevant loading conditions are to be included in the final Loading Manual, see Pt 4, Ch 12, 15.1 General 15.1.4 and Pt 3, Ch 4, 8.1 General.

2.6 Calculation of hull section modulus

2.6.1 The hull midship section modulus is to be calculated in accordance with the requirements of Pt 3, Ch 3, 3.4 Calculation of hull section modulus taking account of Pt 4, Ch 12, 2.6 Calculation of hull section modulus 2.6.2 and Pt 4, Ch 12, 2.6 Calculation of hull section modulus 2.6.3. See also Pt 4, Ch 12, 17.1 Symbols and definitions for split hull arrangements.

2.6.2 Centreline box keels within the hopper spaces may normally be regarded as 100 per cent effective provided that they are effectively scarfed to the vertical keels or equivalent structure at each end of the hopper spaces.

2.6.3 Where a long superstructure or deckhouse is fitted extending within the midship region, the requirements for longitudinal strength in the hull and erection will be specially considered.

2.7 Hull shear strength

2.7.1 Special attention is to be paid to the actual shear forces at the spoil space end bulkheads. The inclusion of the effective thickness of longitudinal bulkheads, centre box keel plating and other longitudinal material at these positions, will be considered in relation to the arrangement of structure proposed.

2.7.2 For ships classed **A1 protected waters service**, see Pt 4, Ch 12, 4.6 Side shell 4.6.1.

2.7.3 The vertical wave shear forces, Q_w , are to be calculated in accordance with Pt 3, Ch 4, 6 Hull shear strength. In dredging conditions, where the dredging draught T_m is greater than T , K_2 may be taken as f_{wd} .

■ Section 3 Deck structure

3.1 Deck plating

3.1.1 Dredgers, hopper dredgers and hopper barges classed for unrestricted service are to have the minimum thicknesses required by Pt 4, Ch 1, 4 Deck structure increased by 2 mm for those areas of the strength deck outside line of openings which are exposed to the weather.

3.1.2 Ships classed **100A1 extended protected waters service** are to have the minimum thicknesses required by Pt 4, Ch 1, 4 Deck structure for all strength deck plating outside line of openings. The minimum value of s , used in the formulae, may be taken as 550 mm.

3.1.3 Ships classed **A1 protected waters service** may have the minimum thicknesses as given in Pt 4, Ch 1, 4 Deck structure for all strength deck plating outside line of openings reduced by 1 mm, with an overall minimum of 5 mm. The minimum value of s , used in the formulae, may be taken as 550 mm.

3.1.4 Strength deck plating within the line of openings in the midship region, and for 0,075L from the ends, is to have a thickness not less than:

$$t = 0,01s \text{ mm}$$

3.1.5 The deck plating thickness and supporting structure may be required to be reinforced in those areas of deck which are liable to be subjected to regular, heavy, impact loads such as could occur when maintaining or inspecting large items of dredging gear, etc. It is recommended that consideration be given to increasing the plating thickness in these areas to:

$$t = 0,02s \text{ mm}$$

= with a minimum

$$t = 10 \text{ mm}$$

3.2 Deck stiffening

3.2.1 The scantlings of deck beams or longitudinals are to comply with the requirements of *Pt 4, Ch 1, 4.3 Deck stiffening*.

3.3 Deck supporting structure

3.3.1 The scantlings of the deck supporting structure are to comply with the requirements of *Pt 4, Ch 1, 4.4 Deck supporting structure*.

■ Section 4 Shell envelope plating

4.1 Keel

4.1.1 On ships over 50 m in length, where there is a centreline well, or where hopper doors are fitted on the ship's centreline, i.e. where no centreline box keel is fitted in a hopper, a keel strake is to be fitted on each side of the well or hopper door opening, dependent upon the proposed docking arrangements for the ship. The width of each keel strake is to be not less than half that required for a centreline keel nor less than 400 mm. The thickness of each keel strake is to be not less than the thickness required for a centreline keel in *Pt 4, Ch 1, 5.2 Keel*.

4.2 Bottom shell

4.2.1 The minimum thickness of bottom shell plating amidships on hopper dredgers and hopper barges classed for unrestricted service is to be 15 per cent greater than that required by *Pt 4, Ch 1, 5.3 Bottom shell and bilge*. The thickness of bottom shell plating on ships classed **A1 protected waters service** is to be not less than:

$$t = (5sL\sqrt{D} \times 10^{-5} + 5) \text{ mm}$$

or that required for *Pt 4, Ch 1, 5.3 Bottom shell and bilge*, whichever is the lesser, but with an overall minimum thickness of 6 mm.

4.2.2 Where hoppers extend outside $0,4L$ amidships, the thicknesses required for the bottom shell amidships are to be maintained for at least two frame spaces beyond the ends of the hoppers before being tapered to the end thicknesses.

4.3 Operating aground

4.3.1 For ships intended to operate aground, see *Pt 4, Ch 12, 7 Bottom strengthening for operating aground*.

4.4 Bottom openings

4.4.1 The corners of hopper door openings and of bucket and ladder wells are generally to be parabolic or elliptical on all ships where L is greater than 50 m, and should generally be rounded on smaller ships. On ships where L is greater than 90 m, the arrangement of hopper and well corners within $0,5L$ amidships should generally be as required for deck hatch corners. The sealing arrangements for hopper doors may lie within the line of the corners, provided that the construction is such as to avoid high stress concentrations in the structure.

4.5 Ships with chines

4.5.1 On ships arranged with two chines each side, the bilge plating should generally be calculated from the bottom plating formulae. On hard chine ships, flanged chines will not generally be approved, but where a chine is formed by knuckling the shell

plating, the radius of curvature, measured on the inside of the plate, is to be not less than 10 times the plate thickness. Where a solid round chine bar is fitted, the bar diameter is to be not less than 50 mm or three times the thickness of the thickest abutting plate, whichever is the greater. Where welded chines are used, the welding is to be built up as necessary to ensure that the shell plating thickness is maintained across the weld.

4.6 Side shell

4.6.1 The thickness of the side shell is to be in accordance with *Pt 4, Ch 1, 5.4 Side shell*. On ships classed **A1 protected waters service** the thickness of the side shell throughout, including at ends, may be reduced by 20 per cent from that required by *Pt 4, Ch 1, 5.4 Side shell* and *Pt 3, Ch 5 Fore End Structure* and *Pt 3, Ch 6 Aft End Structure* as appropriate, provided that the combined shear stress does not exceed 110 N/mm² (11,2 kgf/mm²).

4.6.2 Where high compressive loads occur in the sheerstrake, the thickness may be required to be increased to minimise the likelihood of buckling.

4.7 Swim ends

4.7.1 The plating of swim ends is to have a thickness not less than that required for the bottom shell up to the waterline at draught *T*, see also *Table 12.7.1 Bottom strengthening for operating aground*. It is to have a thickness not less than that required for side shell in the areas more than 1,0 m above the waterline at draught *T_m*. In intermediate areas the thickness may be tapered from the bottom to the side shell requirements.

■ Section 5 Shell envelope framing

5.1 Longitudinal stiffening

5.1.1 The scantlings of bottom and side shell longitudinals are to comply with the requirements given in *Table 12.5.1 Longitudinal stiffening*.

5.1.2 For ships intended to operate aground, see *Pt 4, Ch 12, 7 Bottom strengthening for operating aground*.

5.2 Transverse stiffening

5.2.1 For bottom structure with transverse framing, see *Pt 4, Ch 12, 6 Bottom structure*.

5.2.2 For ships intended to operate aground, see *Pt 4, Ch 12, 7 Bottom strengthening for operating aground*.

5.2.3 The scantlings of side frames amidships are to be in accordance with *Pt 4, Ch 1, 6 Shell envelope framing* for ships classed for unrestricted service or **100A1 extended protected waters service**. The modulus of side frames may be reduced by eight per cent for ships classed **A1 protected waters service**.

5.3 Primary supporting structure at sides

5.3.1 The spacing of transverses supporting side longitudinals is generally to be in accordance with *Pt 4, Ch 1, 6.4 Primary supporting structure*, but is not to exceed 4,0 m.

5.3.2 Transverses supporting side longitudinals are to comply with the requirements of *Pt 4, Ch 1, 6.4 Primary supporting structure*, except for ships classed with a service restriction notation and all ships classed **A1 protected waters service**, where the requirements are given in *Table 12.5.2 Primary supporting structure at sides*.

5.3.3 In way of transverse framing, web frames may be required in way of hopper cross members. Alternative arrangements may be submitted for consideration.

5.3.4 The end connections of side transverses and web frames to deck and bottom transverses abreast of spoil spaces are to be arranged to prevent shear buckling of the members' webs.

5.3.5 For wash bulkheads fitted in lieu of web frames abreast spoil spaces, see *Pt 4, Ch 12, 8.3 Spoil space and well boundaries 8.3.6*.

Table 12.5.1 Longitudinal stiffening

Position of longitudinals	Modulus
(1) Bottom	$Z = \frac{l_e^2 s H k c}{K_1} \text{ cm}^3$ <p>where</p> <p>l_e = effective span of longitudinals, in metres, and is to be taken as not less than 1,85m except as provided for in Pt 4, Ch 12, 6.3 <i>Single bottoms longitudinally framed</i> 6.3.1</p> <p>= In way of single bottoms</p> <p>$H = D$</p> <p>= In way of double bottoms</p> <p>$H = D$ on ships classed 100A1 or 100A1 extended protected waters service</p> <p>= T_m for ships classed A1 protected waters service</p> <p>a factor varying from 1,0 at $\frac{D}{2}$ to $\frac{2060}{3620 - 1560F_B}$ at bottom,</p> <p>c = intermediate values by interpolation. For ships with hogging still water bending moments in loaded conditions and for split hull vessels, $c = 1,0$</p> <p>F_B = as defined in Pt 3, Ch 4, 5.1 <i>Symbols</i></p> <p>K_1 = 120 on ships classed 100A1 or 100A1 extended protected waters service</p> <p>= 150 on ships classed A1 protected waters service</p> <p>k = higher tensile steel factor, see Pt 3, Ch 2, 1 <i>Materials of construction</i></p>
(2) Side shell	<p>(a) For ships classed 100A1 or 100A1 extended protected waters service</p> <p>The minimum modulus of side longitudinals is to be in accordance with Pt 4, Ch 1, 6.2 <i>Longitudinal stiffening</i>.</p> <p>(b) For ships classed A1 protected waters service</p> <p>The modulus required by (a) and reduced by 5 per cent</p>
(3) Bilge	<p>The scantlings of bilge longitudinals are to be graduated between those required for the bottom longitudinals and the lowest side longitudinals</p>

Table 12.5.2 Primary supporting structure at sides

Symbols	Item	Requirement
<p>$h =$ vertical distance from mid-point of span to deck at side, in metres</p> <p>$l_e =$ effective length of supporting member, in metres, see Pt 3, Ch 3, 3 Structural idealisation</p> <p>$I =$ moment of inertia of supporting member, in cm^4, see Pt 3, Ch 3, 3 Structural idealisation</p> <p>$S =$ spacing, or mean spacing, of supporting member, in metres</p> <p>$Z =$ section modulus of supporting member, in cm^3, see Pt 3, Ch 3, 3 Structural idealisation</p>	<p>Transverses supporting side longitudinals amidships</p>	<p>All ships classed 100A1 extended protected waters service: $Z = 9,5Shl_e^2\text{cm}^3$</p> <hr/> <p>All ships classed A1 protected waters service: $Z = 9,0Shl_e^2\text{cm}^3$</p>
	<p>Transverses and web frames supporting side longitudinals abreast of spoil spaces</p>	<p>Inertia of not less than: $I = 2,5l_e Z \text{cm}^4$</p>

■ **Section 6**
Bottom structure

6.1 General

6.1.1 This Section provides for longitudinal or transverse framing of the bottom structure of ships with single or double bottoms.

6.1.2 For ships intended to operate aground, see Pt 4, Ch 12, 7 Bottom strengthening for operating aground.

6.2 Single bottoms transversely framed

6.2.1 The scantlings of single bottom floors, extending for the full width of the ship, are to be in accordance with Pt 4, Ch 1, 7 Single bottom structure irrespective of the length of the ship. Floors below dredging pumps or similar items which could induce large concentrated loads or large dynamic forces, may be required to be of increased strength. Floors may be recessed locally in way of dredging pumps, etc. provided that suitable compensation is arranged.

6.2.2 The spacing of intercostals and longitudinal side girders is to be such as to ensure continuity of strength at bulkheads, ends of spoil spaces and wells and at ends of machinery seats so far as practicable, see also Pt 4, Ch 1, 7 Single bottom structure. An intercostal is to be fitted in the buoyancy space abreast hopper openings when the distance between the hopper opening and the ship's side exceeds 4,0 m.

6.2.3 Abreast of dredging wells and spoil spaces the minimum depth of floor at its inboard end is to be not less than:

$$d_w = 20(B + l_e + 2T_m) \text{ mm}$$

The thickness of the web and area of the face plate are to be as required by Pt 4, Ch 1, 7.2 Girders and floors.

6.3 Single bottoms longitudinally framed

6.3.1 The spacing of transverses is to be in accordance with Pt 4, Ch 12, 5.3 Primary supporting structure at sides 5.3.1, and are to be supplemented by the following arrangements of brackets:

- (a) On the ship's centreline, or on each side of dredging wells where there is no structure on the centreline, the brackets are to be spaced not more than 1,25 m apart and are to extend outboard to the first longitudinal, port and starboard. The longitudinals supported by the brackets may be calculated using a nominal transverse spacing of 1,6 m.
- (b) On ships where the side are transversely framed, the brackets are to be fitted at every frame and are to extend inboard to the first longitudinal on the flat of bottom. This longitudinal is to be based on a span equal to the spacing of the transverses.

(c) The thickness of these intermediate brackets is to be not less than:

$$t = (0,25B + 1,85\sqrt{T_m}) \text{ mm}$$

6.3.2 In areas of high shear loading, the thickness and stiffening of the web plates on transverses, etc. may have to be increased. The depth of transverses is to be not less than 2,5 times the depth of the slot for the bottom longitudinals, and thickness of the web plates is to be not less than 8 mm.

6.3.3 Bottom transverses in spoil space side buoyancy tanks in way of cross-ties are to have a depth, d , of not less than:

$$d = 28B + 205\sqrt{T_m} \text{ mm}$$

Their arrangement, scantlings and end connections are to be such as to provide proper continuity of strength across the ship. The transverses are to be fitted with stiffeners in way of every shell longitudinal. The stiffeners should, in general, be equivalent to flat bars with a depth one-eighth of the transverse at that point and a thickness not less than the thickness of the transverse.

6.4 Double bottom - General

6.4.1 Self-propelled dredgers and reclamation ships of more than 500 tons gross and intended for International voyages are to be provided with a double bottom extending from the collision bulkhead to the after peak bulkhead, as far as this is practicable and compatible with the design and proper working of the ship.

6.4.2 A double bottom need not be fitted in way of watertight compartments used exclusively for the carriage of liquids provided the safety of the ship, in the event of bottom damage, is not thereby impaired.

6.4.3 The double bottom may, however, be interrupted locally, or fitted with wells in way of dredging pumps and other equipment. Where such openings are large, their scantlings and arrangements will be specially considered.

6.4.4 The scantlings are to be in accordance with *Pt 4, Ch 1, 8 Double bottom structure* except for the following:

- (a) The Rule thickness of centre girders may be reduced by 2,0 mm on ships classed **A1 protected waters service**.
- (b) The Rule thickness of side girders may be reduced by 1,0 mm on ships classed **100A1 extended protected waters service**.
- (c) The scantlings of floors, longitudinals and plating supporting the bottom of spaces intended to carry spoil are to be determined in accordance with *Pt 4, Ch 12, 8 Spoil space and well structure*.

6.5 Double bottom with transverse framing

6.5.1 Plate floors may be fitted at every frame or may be spaced not more than 3,0 m apart with the shell and inner bottom plating between these floors supported by bracket floors. However, plate floors are to be fitted at every frame in the following areas:

- (a) As required for *Pt 4, Ch 1, 8.5 Floors*.
- (b) Below spaces from which dredged material will be discharged by grabs.
- (c) In main propulsion and dredging machinery rooms and in peak tanks.
- (d) For three frame spaces at ends of spoil spaces and dredging wells.

6.6 Double bottom with longitudinal framing

6.6.1 In locations other than below spaces intended for dredged spoil the section modulus of inner bottom longitudinals is to be not less than:

$$Z = \frac{l_e^2 e s H k c}{K_1} \text{ cm}^3$$

where

l_e = effective span of longitudinals, in metres, and is to be taken as not less than 1,85 m

s = spacing of longitudinals, in mm

H = height, in metres, from the tank top to the deck at side, (but need not exceed T_m on ships classed **A1 protected waters service**)

c = as defined in *Table 12.5.1 Longitudinal stiffening*

where

$K_1 = 120$ in machinery spaces on ships classed **100A1**

= 150 otherwise.

k = higher tensile steel factor, see *Pt 3, Ch 2, 1 Materials of construction*.

6.6.2 The section modulus of longitudinals below spaces intended for dredged spoil is to comply with the requirements of *Pt 4, Ch 12, 8.3 Spoil space and well boundaries 8.3.7*.

6.6.3 The spacing of transverses is generally to be as for dry cargo ships but is not to exceed 4,0 m. Below main dredging machinery the transverses are generally to be spaced not more than 1,0 m apart.

6.6.4 The ends of longitudinal girders under dredging machinery are to be tapered off or efficiently scarfed into other longitudinal structural items.

■ Section 7 Bottom strengthening for operating aground

7.1 Application

7.1.1 The scantlings of bottom structure are to comply with the requirements given in *Table 12.7.1 Bottom strengthening for operating aground*.

7.1.2 Unless otherwise specified by the Owner, it should be assumed that non-self-propelled dredging and reclamation craft are to operate aground.

Table 12.7.1 Bottom strengthening for operating aground

Item	Requirement	
The following requirements are to be applied to the bottom structure upon which the ship is likely to be supported whilst aground		
(1) Bottom shell, keel and swim end plating	Thickness to be increased by 20% over the minimum requirements of <i>Pt 4, Ch 1, 5 Shell envelope plating</i> , with a minimum of 8 mm	
(2) Bottom longitudinals	Scantlings as required by <i>Table 12.5.1 Longitudinal stiffening(1)</i> taking $K_1 = 74$ and $c = 1,0$	
(3) Bilge longitudinals (where fitted)	Scantlings to be the same as bottom longitudinals	
	Transverse framing	Longitudinal framing
(4) Primary stiffening in way of single bottoms, see Notes 1 and 2	(a) Floors to be fitted at every frame with vertical stiffeners spaced, in general, not more than 1,25 m apart (b) Side girders to be spaced not more than 2,2 m apart and intermediate 100 mm x 10 mm bulb plate longitudinals, or equivalent, fitted	(a) The spacing of transverses or floors is, in general, not to exceed 2,5 m outboard of wells or 1,85 m elsewhere (b) The panel size nearest the shell plating of web plates of transverses or floors is, in general, not to exceed $80t \times 80t$ where t is the actual web thickness (c) Side girders to be spaced not more than 2,2 m apart

(5) Primary stiffening in way of double bottoms, see Notes 1 and 2	<p>(a) Plate floors are to be fitted at every frame with vertical stiffeners spaced, in general, not more than 1,25 m apart</p> <p>(b) Side girders to be spaced not more than 2,5 m apart and intermediate 100 mm x 10 mm bulb plate longitudinals, or equivalent, fitted</p> <p>(c) Where the span of floors between a hopper space and the ship's side exceeds 3,75 m, a longitudinal girder is to be fitted</p>	<p>(a) The spacing of plate floors is, in general, not to exceed 1,85 m</p> <p>(b) Side girders to be spaced not more than 2,5 m apart</p>
<p>Note 1. The scantlings of floors, girders and transverses are to be determined in accordance with the requirements of <i>Pt 4, Ch 12, 6 Bottom structure</i>.</p> <p>Note 2. The number and size of holes in floors, girder and transverses are to be kept to a minimum, see <i>Pt 4, Ch 1, 8 Double bottom structure</i>.</p>		

■ **Section 8**
Spoil space and well structure

8.1 Symbols and definitions

8.1.1 The symbols used in this Section are defined as follows:

ρ_{ef} = effective specific gravity to be taken, as defined in *Table 12.8.1 Effective specific gravity*

h = load head, in metres, measured vertically as follows:

- (a) For plating, the distance from a point one-third of the height of the plate above its lower edge to the sill of the uppermost overflow weir.
- (b) For stiffeners or girders, the distance from the middle of the effective length to the sill of the uppermost overflow weir.

l_e = effective length of stiffening members, in metres, see *Pt 3, Ch 3, 3 Structural idealisation*

s = spacing of stiffeners, in mm

t = plate thickness, in mm

A_1 = cross-sectional area of flange or stiffener, in cm², including coaming plating.

Table 12.8.1 Effective specific gravity

Effective specific gravity less than or equal to 1,4	Effective specific gravity greater than 1,4	
$\rho \leq 1,4$	$\rho > 1,4$	
	for vertical boundaries	for boundaries which have an angle, α with the horizontal plane
$\rho_{ef} = \rho$	$\rho_{ef} = 1,4$	$\rho_{ef} = 1,4 + (\rho - 1,4) (\cos \alpha)^2$

8.1.2 Other symbols are defined in *Pt 4, Ch 12, 1.5 Symbols 1.5.1*.

8.2 General

8.2.1 This Section provides for:

- (a) horizontally and vertically stiffened boundary bulkheads to hoppers, and holds intended for dredged spoil, to ladder wells and to spud wells,
- (b) protection against flooding in the event of the ladder well or adjacent bottom plating being damaged by objects dredged up by bucket dredgers, and
- (c) continuity of transverse strength in spoil spaces and wing tanks abreast of spoil spaces.

8.2.2 As an alternative to the requirements of this section regarding primary structure, scantlings may be derived on the basis of direct calculation methods, see *Pt 4, Ch 12, 18 Direct calculations*.

8.2.3 **Continuity of strength.** Arrangements are to be made to ensure continuity of strength at the ends of longitudinal and well side bulkheads. In general, the design should be such that the bulkheads are connected to bottom and deck girders by means of large, suitably shaped brackets arranged to give a good stress flow at their junctions with both the girders and the bulkheads.

8.2.4 **Ladder well cofferdams.** Ladder wells of trailing suction dredgers are to be isolated from the remainder of the dredger's structure by local cofferdams at least 600 mm wide, or are to be otherwise protected to prevent serious flooding due to the well side plating being breached by the ladder structure should this be damaged in service. Ladder wells of bucket dredgers are to be isolated by cofferdams, the extent and widths of which are to be sufficient to contain any damage to the well side bulkheads or bottom shell plating that could result from the impact of large objects brought up in the dredge buckets. In way of the buckets the cofferdam may be extended outboard in the form of a local watertight double bottom.

8.3 Spoil space and well boundaries

8.3.1 The plating thickness of spoil space boundaries is to be not less than the following:

$$t = 0,0046s f \sqrt{k h \rho_{ef}} + 3,0 \text{ mm, or}$$

$$t = 8,5 \text{ mm, whichever is the greater}$$

In the case of grab dredgers the minimum thickness is to be 10 mm. These thickness requirements also apply to the plating of watertight box keels and inner bottom plating. The value of ρ_{ef} used in the calculations and the height(s) of the overflow weir(s) are to be clearly shown on the midship section plan.

8.3.2 Attention is drawn to the high rate of wear that can occur on spoil space boundaries, and it is recommended that an additional corrosion allowance of 3,0 mm be added on areas subject to particularly onerous conditions. Where such an allowance is added, the fact is to be marked on the relevant plans.

8.3.3 The thickness of plating forming the sides and ends of bucket ladder wells is to be not less than:

$$t = (0,0055s \sqrt{T_m} + 3,0) \text{ mm}$$

In no case, however, is the side plating to have a thickness less than 12 mm nor is the well end plating to have a thickness less than 8,5 mm. Plating forming the boundaries of suction pipe ladder wells is generally to be as required for shell plating. Corrosion allowance on well end plating below bucket ladders may be 2,0 mm.

8.3.4 The thickness of spoil space and ladder well bulkheads may be required to be increased where high shear forces are present.

8.3.5 Bulkheads forming the boundaries of spud wells are to be of increased strength. Each case will be considered on its merits, but in general such bulkheads should have a thickness of not less than 12 mm.

8.3.6 Where non-watertight bulkheads are fitted in the side buoyancy tanks, the thickness of the plating is to be not less than:

(a) $t = 6,5 \text{ mm, or}$

(b) $t = (5,35 + 0,024L) \text{ mm,}$

whichever is the greater. Where the bulkhead is in the form of a wash bulkhead, the openings should be so arranged that, in general, the distance from lightening holes to any slots cut to accommodate side shell or bulkhead longitudinals is at least equal to 1,5 times the depth of the slot. The edges of large openings are to be stiffened.

8.3.7 The section modulus of framing on spoil space boundaries is to be not less than:

$$Z = \frac{0,0113 \rho_{ef} s h l_e^2 k c}{\gamma} \text{ cm}^3$$

where

c = as defined in *Pt 4, Ch 12, 8.3 Spoil space and well boundaries 8.3.7* for longitudinal framing

= 1,0 for transverse framing

γ = 1,4 for rolled or built sections

= 1,6 for flat bars.

ρ_{ef} = effective specific gravity, see *Pt 4, Ch 12, 8.1 Symbols and definitions 8.1.1*

k = higher tensile steel factor, see *Pt 3, Ch 2, 1 Materials of construction*

The section modulus of longitudinals below $\frac{D}{2}$ is to be taken not less than the value obtained at $\frac{D}{2}$.

Table 12.8.2 Definition of c for longitudinal framing

Symbols	Location	c , see Note 2
F_B as defined in <i>Pt 3, Ch 4, 5.1 Symbols</i>	$0,8D$ $\frac{D}{2}$ and above	1,0
	At $\frac{D}{2}$	0,85
	$0,2D$ above base (see Note 1)	$\frac{550}{1590 - 1040F_B}$
	Base line (see Note 1)	$\frac{2060}{3620 - 1560F_B}$
Note 1. For ships with hogging still water bending moments in loaded conditions and for split hull vessels, $c = 1,0$.		
Note 2. Intermediate values are to be calculated by linear interpolation.		

8.3.8 The section modulus of stiffeners bounding wells and deep tanks is to satisfy the requirements of *Pt 4, Ch 1, 9.2 Watertight and deep tank bulkheads*.

8.3.9 For non-watertight bulkheads, the modulus of the stiffeners may be 50 per cent of that required for intact bulkheads. The stiffeners are to be bracketed at top and bottom.

8.3.10 Structure supporting spud well plating and bulkheads below, and in way of, 'A' frames and dredging machinery supports, is to be of substantial construction, account being taken of the dynamic loads likely to occur with the dredging machinery in operation.

8.3.11 Horizontal girders supporting stiffeners on spoil space and ladder well boundaries are, in general, to have scantlings as required by *Pt 4, Ch 1, 9.2 Watertight and deep tank bulkheads* for deep tanks, with ρ and h as defined in *Pt 4, Ch 12, 1.5 Symbols 1.5.1* and *Pt 4, Ch 12, 8.1 Symbols and definitions 8.1.1* respectively and with span, l_e for horizontal girders supporting vertical stiffeners on longitudinal bulkheads, measured between bulkhead bracket and bulkhead bracket, i.e. ignoring any struts which may be fitted between spoil space girder and shell stringer. Alternatively, the section modulus of these horizontal girders may be reduced by 40 per cent from the formula value if struts are fitted on alternate frames between the spoil space girder and a shell stringer. These struts should generally be horizontal and are to have a sectional area as required for pillars by *Pt 4, Ch 1, 4.4 Deck supporting structure* with ρ as defined in *Pt 4, Ch 1, 1.5 Symbols and definitions 1.5.1* and h measured from the inboard end of the strut to the height defined in *Pt 4, Ch 12, 8.1 Symbols and definitions 8.1.1*. Web frames and girders are to have scantlings as required by *Pt 4, Ch 1 General Cargo Ships*, with ρ and h as defined in *Pt 4, Ch 12, 1.5 Symbols 1.5.1* and *Pt 4, Ch 12, 8.1 Symbols and definitions 8.1.1* respectively.

8.4 Cross members

8.4.1 Cross-members are to be fitted within the hopper space in line with the bottom and side shell transverses and with the bulkheads in the side buoyancy spaces. Where the spacing between the cross-members exceeds 4 m, the scantlings of all primary members contributing to the continuity of the transverse strength in the spoil space are to be verified by direct calculations, *see also Pt 3, Ch 1, 2.2 Submission of direct calculations*. Where a box keel is fitted on the centreline, webs are to be fitted within the box keel to ensure proper continuity of strength across the ship in way of the hopper cross-member. The webs required within centreline watertight box keels may have a thickness 3,5 mm less than that required for the hopper cross-members with which they are associated, but their minimum thickness is to be not less than 6,5 mm.

8.4.2 The upper edge of the hopper lower cross-members should, in general, be a height of not less than $\frac{D}{4}$ above the keel in ships with the number 100 in their character of classification. The lower edge should be as low as practicable after allowing for the proper design of hopper doors, suction passages, etc. Lower cross-members may be fabricated from flat plate suitably stiffened or may take the form of a hollow box, generally of triangular cross-section.

8.4.3 The scantlings of box-type cross-members should be determined from the requirements for hopper bulkheads where applicable. When flat plate lower cross-members are fitted, the thickness of the web is to be not less than:

$$t = (0,7B + 3) \text{ mm or } 8,5 \text{ mm}$$

whichever is the greater.

8.4.4 The cross-sectional area of the cross-member web after deducting access openings, lightening holes, etc. is to be not less than:

$$A = 6h_w S_M \text{ cm}^2$$

where

h_w = height, in metres, of the uppermost hopper overflow weir above the keel

S_M = spacing of the cross-member webs, in metres.

8.4.5 The upper edge of the cross-member is to be stiffened by means of a tube having an outside diameter not less than:

$$\delta = 30 / s \text{ mm}$$

where

l_s = span, in metres, of the upper edge of the cross-member (to the centreline box girder if fitted), and a thickness equal to the minimum required cross-tie web thickness, or by an equivalent flange or structure. The lower edge of the cross-member is also to be suitably stiffened.

8.4.6 The cross-member web is to be fitted with stiffeners, spaced not more than $80t$ mm apart having a modulus of not less than:

$$Z = 0,04s l_e^2 \text{ cm}^3.$$

8.4.7 The transverse strength of primary structural members, such as upper and lower cross members and wing tank bulkheads, forming transverse ring systems are to be verified by direct calculations, e.g. finite element calculations on the basis of loads arising from hydrostatic, wave, spoil pressure and loadings on closing appliances of bottom openings. The stresses are in general not to exceed the following values:

Bending + axial stress (σ_b) 130/k N/mm²

Shear stress (T) 70/k N/mm²

Combined stress 180/k N/mm²

= where

k = higher tensile steel factor, *see Pt 3, Ch 2, 1 Materials of construction*.

8.5 Pillars within hoppers

8.5.1 Pillars are generally to comply with the requirements of *Pt 4, Ch 1, 4.4 Deck supporting structure*, account being taken of the maximum forces that can be applied by rams or other gear fitted for the purpose of activating hopper doors or valves.

8.6 Continuous coamings

8.6.1 Continuous coamings are to have a plate thickness of not less than 8,5 mm. A minimum thickness of 10 mm is recommended for coamings on grab dredgers. Where the depth of the coaming exceeds $80t$, the plating is to be stiffened by one or more horizontal members so spaced that the width of the upper panel of plating does not exceed $65t$ and the width(s) of the lower panel(s) do(es) not exceed $80t$.

8.6.2 Where the coaming is stiffened with flat bar members, the members are to have a breadth not less than $0,04S_s$ and a thickness not less than 0,05 times their breadth, or 8,5 mm, whichever is the greater. They are to have a minimum inertia of:

$$I = 2S_s^2 A_1 \text{ cm}^4$$

where

= A_1 and I include the coaming plating for mid-panel above to mid-panel below the stiffener, and

S_s = spacing of the brackets required by this sub-Section, in metres.

= Where stiffeners other than flat bars are used, they are to have at least the same minimum thickness and inertia as required for flat bars.

8.6.3 The upper edge of the coaming is to be stiffened by a fabricated flange, box girder or equivalent structure having a width not less than $0,05S_s$ and an inertia not less than:

$$I = 2,86S_s^2 A_1 \text{ cm}^4$$

where

= A_1 and I include the coaming plating down to mid-panel below

= The thickness and/or attachments of the stiffening member are to be such as to minimise any likelihood of local instability under compression loading.

8.6.4 The coamings are to be supported by substantial brackets spaced generally not more than 3,0 m apart where the coamings have a height of more than 600 mm, nor more than 2,5 m where the coamings have a height of more than 1,0 m but on longitudinally framed ships the brackets are to be arranged in way of each deck transverse. Additional brackets may be required in way of the ends of hopper upper cross-ties, especially those which themselves support hopper door operating rams or similar equipment.

8.6.5 The ends of continuous coamings are to be well scarfed into the ship's structure at the ends of spoil spaces. Unless longitudinal deckhouse bulkheads are fitted in this area, the coamings are to be extended beyond the end of the spoil space opening for a distance of at least one frame space, or 1,5 times the coaming height, whichever is the greater.

■ Section 9 Watertight bulkheads

9.1 Arrangements of bulkheads

9.1.1 The number of watertight bulkheads is to be not less than that required for dry cargo ships, see *Pt 3, Ch 3, 4 Bulkhead requirements*. Their positioning is to be such that one extends the full width of the ship at each end of the spoil spaces, see also *Pt 4, Ch 12, 8.2 General*. Proposals to dispense with one or more of the watertight bulkheads in that part of the ship in way of spoil spaces may be submitted for consideration. In particular, watertight bulkheads need not be fitted within spoil spaces and an increased spacing of bulkheads in the spaces abreast of spoil spaces will generally be accepted provided that:

- (a) Suitable structural compensation is arranged; and
- (b) the stability is checked in the damaged condition.

■ Section 10**Exposed casings****10.1 Scantlings and access**

10.1.1 Exposed casings on ships classed **A1 protected waters service** are to have scantlings as required for deckhouses on dry cargo ships classed **100A1**. On ships classed **100A1**, where T_m equals or exceeds the draught corresponding to a Type 'B-60' ship freeboard, direct access is not permitted to the machinery spaces (including dredging pump-rooms) from the freeboard deck. Doors may be fitted in exposed casing bulkheads, provided that they lead to a space which is of equivalent strength to the casing and is separated from the machinery space by a second watertight door.

■ Section 11**Dredging machinery seats and dredging gear****11.1 Dredging machinery seats**

11.1.1 The seats supporting the main dredging machinery are to be at least as substantial as those required for the main propulsion machinery for dry cargo ships, see *Pt 3, Ch 7, 6 Engine seatings*. Continuity between the longitudinal and transverse members of main engine seats and the ship's bottom structure is to be arranged where practicable. Where floors are cut away below dredging pumps, they are to be fitted with face bars, and special care is to be taken to minimise stress-raising details and to ensure good workmanship.

11.2 Dredging gear

11.2.1 Where masts or derrick posts support dredging gear which will be subjected to vibration or other dynamic loads in addition to its true weight, this must be taken into account in the calculations. The dynamic multiplier should be taken between two and three according to the type of machinery and gear used.

■ Section 12**Ladder wells****12.1 Transverse strength at deck**

12.1.1 Where ladder wells are incorporated so that the length of the well exceeds 1,5 times the width of the deck remaining on each side of the well, the portions of the ship on each side of the well are to be adequately cross-connected in the region of their free ends, unless the design of the ship renders this impracticable, in which case alternative arrangements are to be made to avoid high stress concentrations at the inboard end of the well.

■ Section 13**Fenders****13.1 Fenders and reinforcement in way**

13.1.1 Dredgers designed to work in conjunction with hopper barges are to be fitted with permanent rubbing strakes or fenders extending down to their lowest normal operating waterline. On transversely framed vessels it is recommended that the side structure in way of the lower edge of the fender be reinforced by a stringer and/or cross-ties. It is recommended that, where wooden fenders are fitted to dredgers operating in tropical sea-water, the fenders be cut just above the deepest working waterline and a gap be left sufficient to prevent water soaking up into the fenders.

■ Section 14
Rudders**14.1 Rudders on bucket dredgers**

14.1.1 Where bucket dredgers are arranged with bucket ladders at their stern, the ship's rudders are to be kept well clear of the buckets to minimise the likelihood of damage to the rudders by large objects which may be dredged up. For rudder calculations, see Pt 3, Ch 13 Ship Control Systems.

■ Section 15
Spoil space weirs and overflows**15.1 General**

15.1.1 All spoil spaces are to be arranged to allow the safe and efficient overboard discharge of excess water in all weather conditions in which the ship is classed to operate. In ships over 90 m in length and in all ships classed for unrestricted service the spoil space overflows are to be arranged via enclosed overflow trunks so designed as to keep the decks of the ship clear of spoil and water.

15.1.2 In general, bulwarks are not to be fitted in way of open top spoil spaces on dredging and reclamation craft.

15.1.3 Where a ship operates at the maximum draught that could be assigned in accordance with the *International Convention on Load Lines, 1966*, the overflow arrangements fitted should ensure that when the spoil space is loaded, this draught is not exceeded.

15.1.4 Where a hopper dredger having releasing arrangements for cargo dumping, e.g. bottom doors, etc. is permitted by an Administration to be assigned a freeboard less than that which could be assigned by the *International Convention on Load Lines, 1966*:

- (a) The structural strength and bending moments are to be acceptable for the deeper draught indicated, and
- (b) the dredger is to be operated in a zone of operation and in such weather conditions as are considered appropriate.

15.1.5 Adequate arrangements are to be fitted to prevent overloading under any condition of loading having due regard to trim. The size and position of the overflows are to be confirmed by a loading trial, which is to be carried out when the spoil space is loaded with dredgings of the same density as is likely to be loaded in service.

15.1.6 The cutting of overflow discharge trunk openings in the sheerstrake is to be avoided wherever practicable. In ships over 70 m in length, spoil space overflow discharge trunk openings are not to be cut within 800 mm of the upper edge of the sheerstrake. They are to have corner radii of not less than 150 mm, and suitable compensation is to be arranged. In no case is a discharge trunk to pierce the sheerstrake in way of discontinuities such as breaks of superstructure.

■ Section 16
Scuppers and sanitary discharges and side scuttles**16.1 General**

16.1.1 In all areas where mechanical damage might be likely, all side scuttles, scuppers and discharges, including their valves, controls and indicators, are to be well protected. Consideration is to be given to the likelihood of impact damage to scuttles and discharges due to barges coming alongside, and to scuppers becoming blocked by sand or other spoil which may spill onto the decks or other areas being drained.

16.1.2 Consideration will be given to requests for relaxation of requirements relating to scuttles, scuppers and discharges on ships classed **A1 protected waters service**.

■ *Section 17*

Split hopper dredgers and barges

17.1 Symbols and definitions

17.1.1 The symbols used in this Section are defined as follows:

H = height of spoil above base line, in metres

H_s = depth of hopper seal, in metres

L_h = length of hopper well, in metres

M_H = design horizontal bending moment in hopper side wall, in kN m (tonne-f m). A moment giving rise to tensile stress in the side shell is to be taken as positive

P = net pressure per metre ship length resulting from the spoil pressure and the hydrostatic load, see *Figure 12.17.2 Split hopper dredger*

$$= 4,9 (\rho (H - H_s)^2 - 1,025 (T - H_s)^2) \text{ kN/m}$$

$$= (0,5 (\rho (H - H_s)^2 - 1,025 (T - H_s)^2) \text{ tonne-f/m})$$

S_h = span between the centres of hinges, in metres

17.1.2 Other symbols are defined in *Pt 4, Ch 12, 1.5 Symbols 1.5.1*.

17.2 Hull bending strength

17.2.1 The modulus of the cross-section of the vessel is to be not less than that required by *Pt 4, Ch 12, 2.3 Hull bending strength 2.3.1*. In addition, the combined stress σ_c , at any point on the cross-section of one half hull, is not to exceed the permissible combined stress σ given in *Pt 3, Ch 4, 5.5 Permissible still water bending moments*. The combined stress at any point on the cross-section is to be determined from the following expression:

$$\sigma_c = \left(\frac{M_N}{Z_N} + \frac{M_p}{Z_p} \right) \times 10^{-3} \text{ N/mm}^2 \text{ (kgf/mm}^2\text{)}$$

where

$$M_N = \pm M_V \cos \varphi \pm M_H \sin \varphi \text{ kN m (tonne-f m)}$$

$$M_p = \pm M_H \cos \varphi \pm M_V \sin \varphi \text{ kN m (tonne-f m)}$$

$$M_V = \pm 0,5 (M_s + M_w) \text{ kN m (tonne-f m)}$$

where the still water bending moments hogging and sagging are to be combined with the appropriate wave bending moment to give a total moment, M_V , hogging (positive) and sagging (negative)

M_w is defined in *Pt 4, Ch 12, 1.5 Symbols 1.5.1*.

$$f_1 = \text{ship service factor, see Table 12.2.1 Ship service factors } f_1 \text{ and } f_{wd}$$

$$M_H = 0,125PL_h(2S_h - L_h) \pm M_L \text{ kN m (tonne-f m)}$$

$$M_L = 0,286 f_1 L^2 B \text{ kN m (} 0,029 f_1 L^2 B \text{ tonne-f m)}$$

$$P = 4,9(\rho(H - H_s)^2 - 1,025 (T - H_s)^2) \text{ kN m}$$

$$= (0,5(\rho(H - H_s)^2 - 1,025 (T - H_s)^2) \text{ tonne-f m)}$$

Account is to be taken of the sign of individual bending moment component in the determination of M_N , M_p , M_V and M_H

I_{NN} = second moment of area of the section of one half hull for all longitudinal continuous material above principal axis NN, in m^4

I_{PP} = second moment of area of the section of one half hull for all longitudinal continuous material about principal axis PP, in m^4

$Z_P = \frac{I_{PP}}{y_P}$ in m^3 , the modulus of section to a point y_P m, from the principal axis PP

$Z_N = \frac{I_{NN}}{y_N}$ in m^3 , the modulus of section to a point y_N m, from the principal axis NN

φ = angle of rotation of the principal axis NN with respect to the global horizontal axis YY, in degrees

See also Figure 12.17.1 *Split hulled vessels*.

17.2.2 The combined stress for dredging conditions where draught T_m exceeds T , is not to exceed the permissible combined stress, σ_c obtained from Pt 4, Ch 12, 17.2 Hull bending strength 17.2.1.

The combined stress is to be obtained from the expression for σ_c given in Pt 4, Ch 12, 17.2 Hull bending strength 17.2.1, substituting the following expression of M_V :

$$M_V = \pm 0,5 (M_{sm} + M_{wd}) \text{ kN m (tonne-f m)}$$

where

$M_{wd} = 0,56 f_2 M_{wo}$ and M_{wo} is determined from Pt 3, Ch 4, 5.2 Design vertical wave bending moments, using C_{bm} in place of C_b and f_2 is given in Pt 3, Ch 4, 5.2 Design vertical wave bending moments.

17.3 Separation arrangements

17.3.1 Hinges, actuating and locking devices provided to facilitate separation of the split hulls to discharge spoil are to be of efficient design and of adequate strength and scantlings to ensure safe discharge operations. Hydraulic rams or other actuating devices are to have sufficient power to ensure controlled opening operations and to achieve closing of the hulls in all anticipated weather conditions.

17.3.2 Locking devices are to be of a suitable design and strength to ensure that accidental separation of the hulls cannot occur due to ship motions and vibrations.

17.3.3 Hinge pin gudgeons are to be efficiently connected to the hull structure by means of brackets or equivalent and effectively integrated with local structure which is to be suitably reinforced. Suitable reinforcement is to be fitted to local hull structure in way of anchorages for rams and locking devices to ensure efficient transmission of loading from these devices into the hull.

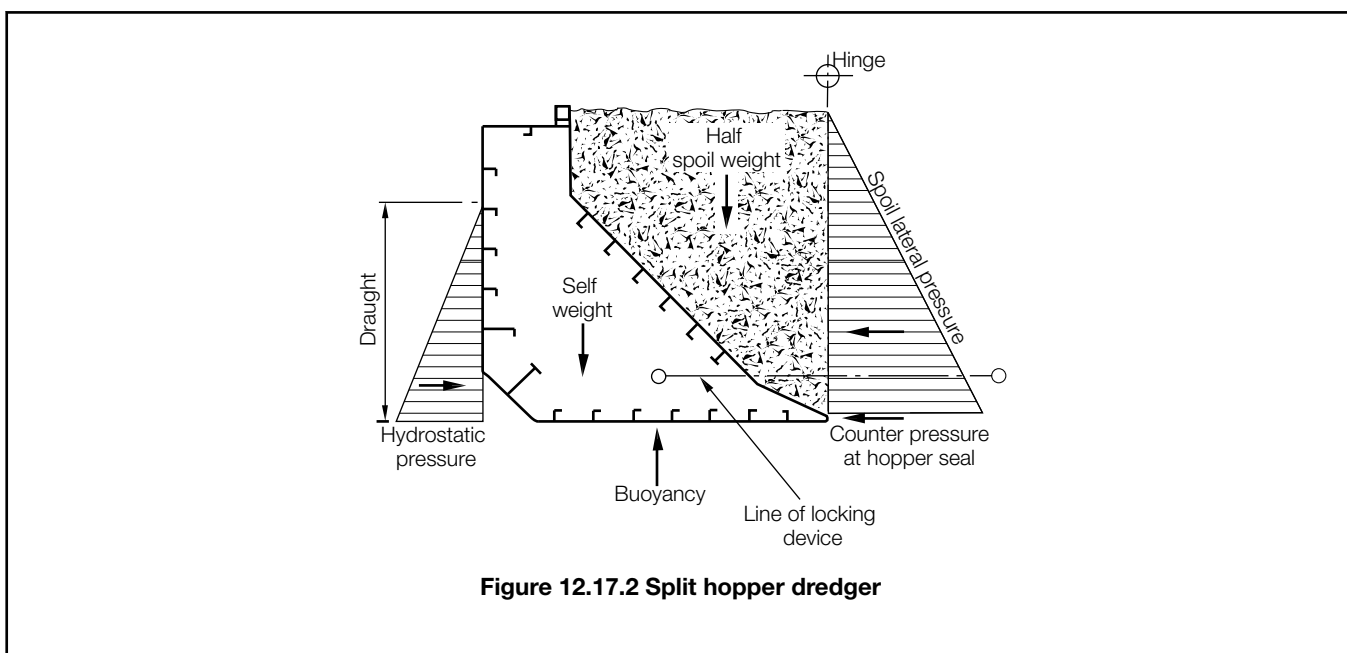
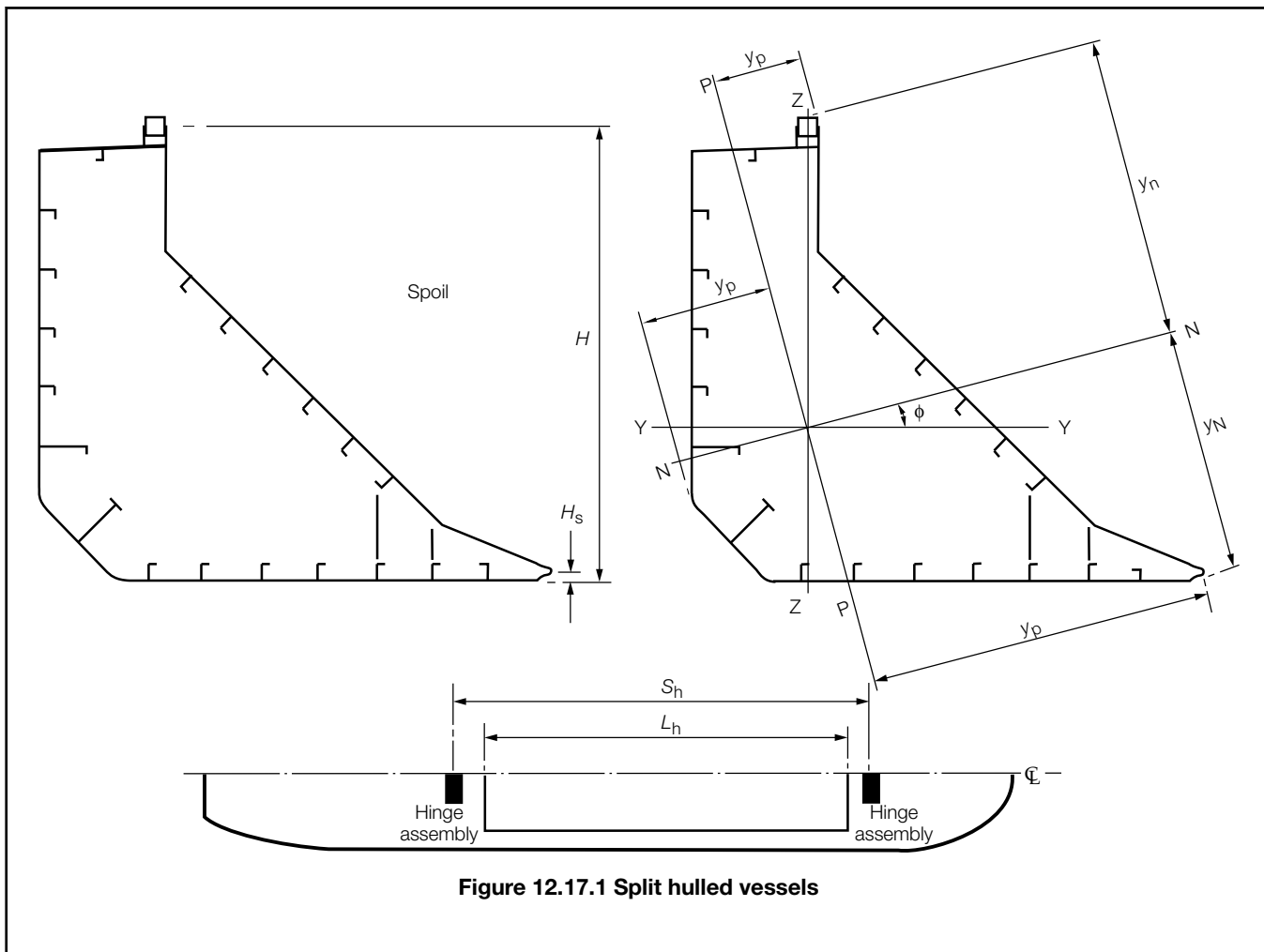

17.3.4 The forces acting on hinges, actuating mechanisms and locking devices are to be determined by direct calculations based on the maximum combination of loading which can be expected in any service condition. In general, this will require the resolution of the static and dynamic systems of force acting on the hulls taking due account of the relative locations of hinges, actuating mechanisms and locking devices. *Figure 12.17.2 Split hopper dredger* illustrates a typical arrangement of hinges and mechanisms together with associated static loads. In general, one half of the load acting on one half hull may be assumed to act on the forward hinge assembly and one half on the after hinge assembly.

17.4 Hinge pins

17.4.1 The diameter of the hinge pins is to be determined using the maximum resultant shear force acting on the pin cross-section in conjunction with an average shear stress not exceeding $\frac{62}{k} \text{ N/mm}^2 \left(\frac{6,3}{k} \text{ kgf/mm}^2 \right)$.

In no case is the diameter of the hinge pin to be less than that calculated from the following expression:

$$D_p = 20 \sqrt{\frac{L^{0,5} B D k}{n}} \text{ mm}$$

where

k = higher tensile steel factor, see *Pt 3, Ch 2, 1 Materials of construction*

n = the number of pin cross-sections resisting shear forces

and L , B and D are defined in *Pt 4, Ch 12, 1.5 Symbols 1.5.1*.

17.4.2 Where arrangements are such that hinge pins are subjected to significant bending, the diameter of the pins will be specially considered.

■ Section 18

Direct calculations

18.1 Application

18.1.1 Direct calculations may be used to assess the scantlings of primary structure in spoil spaces and adjacent structure.

18.1.2 Direct calculations may be required to be submitted in respect of unusual structural arrangements.

18.2 Procedures

18.2.1 Methods applied for direct calculations of scantlings will be given individual consideration dependent on the particular structural configuration, see also *Pt 3, Ch 1, 3.1 Alternative arrangements and scantlings*.

CLASSIFICATION		
PART	1	REGULATIONS
PART	2	RULES FOR THE MANUFACTURE, TESTING AND CERTIFICATION OF MATERIALS
PART	3	SHIP STRUCTURES (GENERAL)
PART	4	SHIP STRUCTURES (SHIP TYPES)

PART	5	MAIN AND AUXILIARY MACHINERY
		CHAPTER 1 GENERAL REQUIREMENTS FOR THE DESIGN AND CONSTRUCTION OF MACHINERY
		CHAPTER 2 RECIPROCATING INTERNAL COMBUSTION ENGINES
		CHAPTER 3 STEAM TURBINES
		CHAPTER 4 GAS TURBINES
		CHAPTER 5 GEARING
		CHAPTER 6 MAIN PROPULSION SHAFTING
		CHAPTER 7 PROPELLERS
		CHAPTER 8 SHAFT VIBRATION AND ALIGNMENT
		CHAPTER 9 PODDED PROPULSION UNITS
		CHAPTER 10 STEAM RAISING PLANT AND ASSOCIATED PRESSURE VESSELS
		CHAPTER 11 OTHER PRESSURE VESSELS
		CHAPTER 12 PIPING DESIGN REQUIREMENTS
		CHAPTER 13 SHIP PIPING SYSTEMS
		CHAPTER 14 MACHINERY PIPING SYSTEMS
		CHAPTER 15 PIPING SYSTEMS FOR OIL TANKERS
		CHAPTER 16 WATER JET SYSTEMS
		CHAPTER 17 REQUIREMENTS FOR FUSION WELDING OF PRESSURE VESSELS AND PIPING
		CHAPTER 18 INTEGRATED PROPULSION SYSTEMS
		CHAPTER 19 STEERING ARRANGEMENTS
		CHAPTER 20 AZIMUTH THRUSTERS
		CHAPTER 21 REQUIREMENTS FOR CONDITION MONITORING SYSTEMS AND MACHINERY CONDITION-BASED MAINTENANCE SYSTEMS
		CHAPTER 22 PROPULSION AND STEERING MACHINERY REDUNDANCY
		CHAPTER 23 SAFE RETURN TO PORT AND ORDERLY EVACUATION AND ABANDONMENT IN PASSENGER SHIPS
		CHAPTER 24 EMISSIONS ABATEMENT PLANT FOR COMBUSTION MACHINERY
		CHAPTER 25 BALLAST WATER TREATMENT SYSTEM AND INSTALLATION
PART	6	CONTROL, ELECTRICAL, REFRIGERATION AND FIRE
PART	7	OTHER SHIP TYPES AND SYSTEMS
PART	8	RULES FOR ICE AND COLD OPERATIONS

Section

	Scope
1	General
2	Plans and particulars
3	Operating conditions
4	Machinery room arrangements
5	Trials
6	Quality Assurance Scheme for Machinery
7	Spare gear for machinery installations

■ Scope

The Chapters in this Part cover the construction and installation of main propulsion and auxiliary machinery systems, together with their associated equipment, boilers, pressure vessels, pumping and piping arrangements and steering gear fitted in classed ships.

■ Section 1 General

1.1 Machinery to be constructed under survey

1.1.1 In ships built under Special Survey, all important units of equipment are to be surveyed at the manufacturer's works. The workmanship is to be to the Surveyor's satisfaction and the Surveyor is to be satisfied that the components are suitable for the intended purpose and duty. Examples of such units are:

- Main propulsion engines including their associated gearing, flexible couplings, scavenge blowers and superchargers.
- Boilers supplying steam for propulsion or for services essential for the safety or the operation of the ship at sea, including superheaters, economisers, desuperheaters, steam heated steam generators and steam receivers. All other boilers having working pressures exceeding 3,4 bar (3,5 kgf/cm²), and having heating surfaces greater than 4,65 m².
- Auxiliary engines which are the source of power for services essential for safety or for the operation of the ship at sea.
- Steering machinery.
- Athwartship thrust units, their prime movers and control mechanisms.
- All pumps necessary for the operation of main propulsion and essential machinery, e.g. boiler feed, cooling water circulating, condensate extraction, fuel oil and lubricating oil pumps.
- All heat exchangers necessary for the operation of main propulsion and essential machinery, e.g. air, water and lubricating oil coolers, fuel oil and feed water heaters, de-aerators and condensers, evaporators and distiller units.
- Air compressors, air receivers and other pressure vessels necessary for the operation of main propulsion and essential machinery. Any other unfired pressure vessels for which plans are required to be submitted as detailed in *Pt 5, Ch 11, 1.6 Plans*.
- All pumps essential for safety of the ship, e.g. fire, bilge and ballast pumps.
- Valves and other components intended for installation in pressure piping systems having working pressures exceeding 7 bar.
- Alarm and control equipment as detailed in *Pt 6, Ch 1 Control Engineering Systems*.
- Electrical equipment and electrical propelling machinery as detailed in *Pt 6, Ch 2 Electrical Engineering*.

General Requirements for the Design and Construction of Machinery

Part 5, Chapter 1 Section 2

1.2 Survey for classification

1.2.1 The Surveyors are to examine and test the materials and workmanship from the commencement of work until the final test of the machinery under full power working conditions. Any defects, etc. are to be indicated as early as possible. On completion, the Surveyors will submit a report and if this is found to be satisfactory by the Committee a certificate will be granted and an appropriate notation will be assigned in accordance with *Pt 1, Ch 2 Classification Regulations*.

1.3 Alternative system of inspection

1.3.1 Where items of machinery are manufactured as individual or series produced units the Committee will be prepared to give consideration to the adoption of a survey procedure based on quality assurance concepts utilising regular and systematic audits of the approved manufacturing and quality control processes and procedures as an alternative to the direct survey of individual items.

1.3.2 In order to obtain approval, the requirements of *Pt 5, Ch 1, 6 Quality Assurance Scheme for Machinery* are to be complied with.

1.4 Departures from the Rules

1.4.1 Where it is proposed to depart from the requirements of the Rules, the Committee will be prepared to give consideration to the circumstances of any special case.

1.4.2 Any novelty in the construction of the machinery, boilers or pressure vessels is to be reported to the Committee.

■ Section 2 Plans and particulars

2.1 Plans

2.1.1 Before the work is commenced, plans in triplicate of all machinery items, as detailed in the Chapters giving the requirements for individual systems, are to be submitted for consideration. The particulars of the machinery, including power ratings, grade(s) of fuel and design calculations, where applicable, necessary to verify the design, are also to be submitted. Any subsequent modifications are subject to approval before being put into operation. It will not be necessary for plans and particulars to be submitted for each ship, provided the basis plans for the engine size and type have previously been approved as meeting the requirements of these Rules. Any alterations to basis design materials or manufacturing procedure are to be re-submitted for consideration.

2.2 Materials

2.2.1 The materials used in the construction are to be manufactured and tested in accordance with the requirements of the *Rules for the Manufacture, Testing and Certification of Materials, July 2015*. Materials for which provision is not made therein may be accepted, provided that they comply with an approved specification and such tests as may be considered necessary.

2.2.2 Materials used in the construction of machinery and its installation are not to contain asbestos.

2.3 Welding

2.3.1 Welding consumables, plant and equipment are to be in accordance with the requirements specified in *Ch 13, 1.8 Welding equipment and welding consumables* of the Rules for Materials.

2.3.2 Welding procedures and welder qualifications are to be tested and qualified in accordance with the requirements specified in *Ch 12 Welding Qualifications* of the Rules for Materials.

2.3.3 Production weld tests are to be carried out where specified in the subsequent Chapters of these Rules.

2.3.4 All finished welds are to be subjected to non-destructive examination in accordance with the requirements specified in *Ch 13, 2.12 Non-destructive examination of welds* of the Rules for Materials and or the requirements specified in the subsequent chapters of these Rules.

■ Section 3

Operating conditions

3.1 Availability for operation

3.1.1 The design and arrangement are to be such that the machinery can be started and controlled on board ship, without external aid, so that the operating conditions can be maintained under all circumstances.

3.1.2 Machinery is to be capable of operating at defined power ratings with a range of fuel grades specified by the engine, boiler or machinery manufacturer and agreed by the Owner/Operator.

3.1.3 Machinery is to be capable of operating satisfactorily in accordance with the manufacturer's stated operating conditions within an operational profile specified for the ship by the Owner/Operator and agreed by the manufacturer/system designer.

3.2 Fuel

3.2.1 The flash point (closed cup test) of fuel oil for use in ships classed for unrestricted service is, in general, to be not less than 60°C.

3.2.2 For emergency generator engines, fuel having a flash point of not less than 43°C may be used.

3.2.3 Fuels with flash points lower than 60°C, but not less than 43°C unless specially approved, may be used in ships intended for service restricted to geographical limits where it can be ensured that the temperature of the machinery and boiler spaces will always be 10°C below the flash point of the fuel. In such cases, safety precautions and the arrangements for storage and pumping will be specially considered.

3.2.4 The use of fuel having a lower flash point than specified in *Pt 5, Ch 1, 3.2 Fuel 3.2.1* to *Pt 5, Ch 1, 3.2 Fuel 3.2.3* as applicable may be permitted provided that such fuel is not stored in any machinery space and the arrangements for the complete installation are specially approved.

3.2.5 For engines operating on 'boil-off' vapours from the cargo, see Lloyd's Register's (hereinafter referred to as 'LR') *Rules for Ships for Liquefied Gases*.

3.3 Power ratings

3.3.1 In the Chapters where the dimensions of any particular component are determined from shaft power, P , in kW (H , in shp), and revolutions per minute, R , the values to be used are to be derived from the following:

- For main propelling machinery, the maximum shaft power and corresponding revolutions per minute giving the maximum torque for which the machinery is to be classed.
- For auxiliary machinery, the maximum continuous shaft power and corresponding revolutions per minute which will be used in service.

3.4 Definitions

3.4.1 Main propulsion engines and turbines are defined as those which drive main propelling machinery directly or indirectly through mechanical shafting and which may also drive electrical generators to provide power for auxiliary services. Auxiliary engines and turbines are defined as those coupled to electrical generators which provide power for auxiliary services, for electrical main propulsion motors or a combination of both.

3.4.2 Units and formulae included in the Rules are shown in SI units followed by metric units in brackets, where appropriate.

3.4.3 Where the metric version of shaft power, i.e. (shp), appears in the Rules, 1 shp is equivalent to 75 kgf m/s or 0,735 kW.

3.4.4 Pressure gauges may be calibrated in bar, where:

$$1 \text{ bar} = 0,1 \text{ N/mm}^2 = 1,02 \text{ kgf/cm}^2.$$

3.5 Ambient reference conditions

3.5.1 The rating for classification purposes of main and essential auxiliary machinery intended for installation in sea-going ships to be classed for unrestricted (geographical) service is to be based on a total barometric pressure of 1000 mb, an engine room ambient temperature or suction air temperature of 45°C, a relative humidity of 60 per cent and sea-water temperature or,

General Requirements for the Design and Construction of Machinery

Part 5, Chapter 1 Section 3

where applicable, the temperature of the charge air coolant at the inlet of 32°C. The equipment manufacturer is not expected to provide simulated ambient reference conditions at a test bed.

3.5.2 In the case of a ship to be classed for restricted service, the rating is to be suitable for the temperature conditions associated with the geographical limits of the restricted service, see *Pt 1, Ch 2 Classification Regulations*.

3.6 Ambient operating conditions

3.6.1 Main and essential auxiliary machinery and equipment is to be capable of operating satisfactorily under the conditions shown in *Table 1.3.1 Ambient operating conditions*.

3.6.2 Where it is intended to allow for operation in ambient temperatures outside those shown in *Table 1.3.1 Ambient operating conditions*, the permissible temperatures and associated periods of time are to be specified and details are to be submitted for consideration. Propelling and essential auxiliary machinery, see *Pt 1, Ch 2, 2.8 Descriptive notes 2.8.1*, is to retain a continuous level of functional capability under these conditions and any level of degraded performance is to be defined. Operation under these circumstances is not to be the cause of damage to equipment in the system and is additionally to be acceptable to the National Authority of the country in which the ship is to be registered.

Table 1.3.1 Ambient operating conditions

Air		
Installations, Components	Location, arrangement	Temperature range (°C)
Machinery and electrical installations	In enclosed spaces	0 to +45, see Note 1
	On machinery component, boilers. In spaces subject to higher and lower temperatures	According to specific local conditions, see Note 2
	On the open deck	-25 to +45, see Note 1
Water		
Coolant		Temperature (°C)
Sea-water or charge air coolant inlet to charge air cooler		-2 to +32, see Notes 1 and 3
<p>Note 1. For ships intended to be classed for restricted service, a deviation from the temperatures stated may be considered.</p> <p>Note 2. Details of local environmental conditions are stated in Annex B of IEC 60092: <i>Electrical installations in ships – Part 101: Definitions and general requirements</i>.</p> <p>Note 3. Charge air cooling arrangements utilising re-circulated cooling to maintain temperatures in a different range are accepted where the machinery and equipment operation is not degraded with a primary supply of cooling in the temperature range stated in this Table.</p>		

3.7 Inclination of ship

3.7.1 Main and essential auxiliary machinery is to operate satisfactorily under the conditions as shown in *Table 1.3.2 Inclination of ship*.

3.7.2 Any proposal to deviate from the angles given in *Table 1.3.2 Inclination of ship* will be specially considered taking into account the type, size and service conditions of the ship.

3.7.3 The dynamic angles of inclination in *Table 1.3.2 Inclination of ship* may be exceeded in certain circumstances dependent upon ship type and operation. The Shipbuilder is, therefore, to ensure that the machinery is capable of operating under these angles of inclination.

Table 1.3.2 Inclination of ship

Installations, components	Angle of inclination, degrees, see Note 1			
	Athwartships		Fore-and-aft	
	Static	Dynamic	Static	Dynamic

General Requirements for the Design and Construction of Machinery

Part 5, Chapter 1 Section 3

Main and auxiliary machinery essential to the propulsion and safety of the ship	15	22,5	5 see Note 2	7,5
Emergency machinery and equipment fitted in accordance with Statutory Requirements	22,5 see Note 3	22,5 see Note 3	10	10
<p>Note 1. Athwartships and fore-and-aft inclinations may occur simultaneously.</p> <p>Note 2. Where the length of the ship exceeds 100 m, the fore-and-aft static angle of inclination may be taken as:</p> $\frac{500}{L} \text{ degrees}$ <p>where L = length of ship, in metres.</p> <p>Note 3. In ships for the carriage of liquefied gas and of liquid chemicals the emergency machinery and equipment fitted in accordance with Statutory Requirements is also to remain operable with the ship flooded to a final athwartships inclination to a maximum angle of 30°.</p>				

3.8 Power conditions for generator sets

3.8.1 Auxiliary engines coupled to electrical generators are to be capable under service conditions of developing continuously the power to drive the generators at full rated output (kW) and in the case of oil engines and gas turbines, of developing for a short period (15 minutes) an overload power of not less than 10 per cent, *see Pt 6, Ch 2, 8.2 Hazard identification and assessment*. In the case of oil engines, they are to be tested at works trials at an overload power of 10 per cent for a period of 30 minutes, *see Table 2.11.1 Scope of works trials for engines in Pt 5, Ch 2 Reciprocating Internal Combustion Engines*.

3.8.2 Engine builders are to satisfy the Surveyors by tests on individual engines that the above requirements, as applicable, can be complied with, due account being taken of the difference between the temperatures under test conditions and those referred to in *Pt 5, Ch 1, 3.5 Ambient reference conditions*. Alternatively, where it is not practicable to test the engine/generator set as a unit, type tests (e.g. against a brake) representing a particular size and range of engines may be accepted. With oil engines and gas turbines any fuel stop fitted is to be set to permit the short period overload power of not less than 10 per cent above full rated output (kW) being developed.

3.9 Astern power

3.9.1 Sufficient astern power is to be provided to maintain control of the ship in all normal circumstances.

3.9.2 Astern turbines are to be capable of maintaining in free route astern 70 per cent of the ahead revolutions, corresponding to the maximum propulsion shaft power for which the machinery is to be classed, for a period of at least 30 minutes without undue heating of the ahead turbines and condensers.

3.10 Machinery interlocks

3.10.1 Interlocks are to be provided to prevent any operation of engines or turbines under conditions that could hazard the machinery and personnel. These are to include 'turning gear engaged', 'low lubricating oil pressure', where oil pressure is essential for the prevention of damage during start up, 'shaft brake engaged' and where machinery is not available due to maintenance or repairs. The interlock system is to be arranged to be 'fail safe'.

3.10.2 Where machinery is provided with manual turning gear, warning devices or notices may be provided as an alternative to interlocks as required by *Pt 5, Ch 1, 3.10 Machinery interlocks 3.10.1*.

■ Section 4

Machinery room arrangements

4.1 Accessibility

4.1.1 Accessibility, for attendance and maintenance purposes, is to be provided for machinery plants.

4.2 Machinery fastenings

4.2.1 Bedplates, thrust seatings and other fastenings are to be of robust construction, and the machinery is to be securely fixed to the ship's structure to the satisfaction of the Surveyor.

4.3 Resilient mountings

4.3.1 The dynamic angles of inclination in *Table 1.3.2 Inclination of ship* may be exceeded in certain circumstances dependent upon ship type and operation. The Shipbuilder is, therefore, to ensure that the vibration levels of flexible pipe connections, shaft couplings and mounts remain within the limits specified by the component manufacturer for the conditions of maximum dynamic inclinations to be expected during service, start-stop operation and the natural frequencies of the system. Due account is to be taken of any creep that may be inherent in the mount.

4.3.2 Anti-collision chocks are to be fitted together with positive means to ensure that manufacturers' limits are not exceeded. Suitable means are to be provided to accommodate the propeller thrust.

4.3.3 A plan showing the arrangement of the machinery together with documentary evidence of the foregoing is to be submitted.

4.4 Ventilation

4.4.1 All spaces including engine and cargo pump spaces, where flammable or toxic gases or vapours may accumulate, are to be provided with adequate ventilation under all conditions.

4.4.2 Machinery spaces of category A shall be adequately ventilated so as to ensure that when machinery or boilers therein are operating at full power in all weather conditions, including heavy weather, a sufficient supply of air is maintained to the spaces for the safety and comfort of personnel and the operation of the machinery. Any other machinery space shall be adequately ventilated, as appropriate for the purpose of that machinery space.

4.5 Fire protection

4.5.1 All surfaces of machinery where the surface temperature may exceed 220°C and where impingement of flammable liquids may occur are to be effectively shielded to prevent ignition. Where insulation covering these surfaces is oil-absorbing or may permit penetration of oil, the insulation is to be encased in steel or equivalent.

4.6 Means of escape

4.6.1 For means of escape from machinery spaces, see SOLAS 1974 as amended Regulation II-2/ 4.1 *Means of escape on passenger ships* or 4.2 *Means of escape on cargo ships*, as applicable.

4.7 Communications

4.7.1 Two independent means of communication are to be provided between the bridge and engine room control station from which the engines are normally controlled, see also Pt 6, Ch 1, 2 *Essential features for control, alarm and safety systems*.

4.7.2 One of these means is to visually indicate the order and response, both at the engine room control station and on the bridge.

4.7.3 At least one means of communication is to be provided between the bridge and any other control position(s) from which the propulsion machinery may be controlled.

4.8 Category A machinery spaces

4.8.1 'Machinery spaces of Category A' are those spaces and trunks to such spaces which contain:

-
- (a) internal combustion machinery used for main propulsion; or
 - (b) internal combustion machinery used for purposes other than main propulsion where such machinery has in the aggregate a total power output of not less than 375 kW; or
 - (c) any oil-fired boiler or fuel oil unit.
-

■ Section 5 Trials

5.1 Inspection

5.1.1 Tests of components and trials of machinery, as detailed in the Chapters giving the requirements for individual systems, are to be carried out to the satisfaction of the Surveyors.

5.2 Sea trials

5.2.1 For all types of installation, the sea trials are to be of sufficient duration, and carried out under normal manoeuvring conditions, to prove the machinery under power. The trials are also to demonstrate that any vibration which may occur within the operating speed range is acceptable.

5.2.2 The trials are to include demonstrations of the following:

- (a) The adequacy of the starting arrangements to provide the required number of starts of the main engines.
- (b) The ability of the machinery to reverse the direction of thrust of the propeller in sufficient time, under normal manoeuvring conditions, and so bring the ship to rest from maximum service speed. Results of the trials to be recorded.
- (c) In turbine installations, the ability to permit astern running at 70 per cent of the full power ahead revolutions without adverse effects. This astern trial need only be of 15 minutes' duration, but may be extended to 30 minutes at the Surveyor's discretion.

5.2.3 Where controllable pitch propellers are fitted, the free route astern trial is to be carried out with the propeller blades set in the full pitch astern position. Where emergency manual pitch setting facilities are provided, their operation is to be demonstrated to the satisfaction of the Surveyors.

5.2.4 In geared installations, prior to full power sea trials, the gear teeth are to be suitably coated to demonstrate the contact markings, and on conclusion of the sea trials all gears are to be opened up sufficiently to permit the Surveyors to make an inspection of the teeth. The marking is to indicate freedom from hard bearing, particularly towards the ends of the teeth, including both ends of each helix where applicable. The contact is to be not less than that required by *Pt 5, Ch 5, 4.2 Accuracy of gear cutting and alignment* or *Pt 5, Ch 5, 5.2 Meshing tests*, as applicable.

5.2.5 The following information is to be available on board for the use of the master and designated personnel:

- The results of trials to determine stopping times, ship headings and distance;
- For ships having multiple propellers, the results of trials to determine the ability to navigate and manoeuvre with one or more propellers inoperative.
- For ships having a single propulsor driven by multiple engines or electric motors, the results of trials to determine the ability to navigate and manoeuvre with the largest engine or electric motor inoperative.

5.2.6 Where the ship is provided with supplementary means for manoeuvring or stopping, the effectiveness of such means are to be demonstrated and recorded as referred to in *Pt 5, Ch 1, 5.2 Sea trials 5.2.5*.

5.2.7 The stopping distance achieved when ship is initially proceeding ahead with a speed of at least 90 per cent of the ship's speed corresponding to 85 per cent of the maximum rated propulsion power should not exceed 15 ship lengths after the astern order has been given. However, if the displacement of the ship makes this criterion impracticable then in no case should the stopping distance exceed 20 ship lengths.

5.2.8 All trials are to be to the Surveyor's satisfaction.

■ Section 6

Quality Assurance Scheme for Machinery

6.1 General

6.1.1 The Quality Assurance Scheme for Machinery (QAM Scheme) is an alternative to direct survey and certification of machinery components and equipment required by the Rules. Under the QAM Scheme LR will consider the extent to which manufacturing processes and control procedures ensure conformity of that machinery to Rules, technical specifications and any other applicable standards or codes.

6.1.2 This QAM Scheme is applicable to items manufactured under closely controlled conditions. The products for which the QAM Scheme is applicable are provided in LR's ShipRight Procedure *Approval of a Manufacturer according to the Quality Assurance Scheme for Machinery*.

6.1.3 The QAM Scheme does not reduce the test requirements to be carried out in accordance with LR's Rules.

6.2 Definitions

6.2.1 The following definitions apply in the context of this Section:

6.2.2 QAM Scheme audit

An audit, conducted by LR at the manufacturer's, or their supplier's or subcontractor's, works, of their products and/or processes, which may include direct survey, in order to provide confidence that products are manufactured, tested and inspected in accordance with LR's Rules. Periodicity of surveillance audits is as agreed in the QAM Scheme Certification Schedule, see LR's ShipRight Procedure *Approval of a Manufacturer according to the Quality Assurance Scheme for Machinery*.

6.2.3 Assessment

A review, conducted by LR, of evidence gained through a number of sources, such as documentation, submitted by the manufacturer, supplier or subcontractor, and regular QAM Scheme audit reports, in order to verify that products are manufactured, tested and inspected in accordance with the Rules.

6.2.4 Manufacturer

A company who contracts to supply components or equipment products to a customer or user and applies for approval under the QAM Scheme.

6.2.5 Supplier

A company who contracts to supply materials, components or equipment products to the Manufacturer applying for approval under the QAM Scheme.

6.2.6 Sub-contractor

A company who contracts to deliver a service to a supplier or manufacturer under the agreed QAM Scheme arrangements.

6.3 QAM Scheme Arrangements

6.3.1 A manufacturer may apply to be approved under the QAM Scheme where the following requirements are met:

- (a) The manufacturer has a quality management system which has been certified as meeting the requirements of ISO 9001, or industry-specific equivalent standard, by a certification body accredited by a member of the International Accreditation Forum and recognised by LR.
- (b) The manufacturer has processes in place suitable for the products to be certified under the QAM Scheme.
- (c) The manufacturer has a satisfactory and documented history of quality performance in the supply of products for which certification under the QAM Scheme is requested.

6.3.2 The scope and arrangements for survey, identification and certification of products covered by the QAM Scheme are to be agreed with LR and will be detailed in a Scheme Certification Schedule. Survey will be based on a technical audit approach, focussing on product realisation. Direct survey may also be used where it is considered appropriate to do so.

6.3.3 The QAM Scheme procedures given in LR's ShipRight Procedure *Approval of a Manufacturer according to the Quality Assurance Scheme for Machinery* are to be complied with.

6.3.4 Where LR is satisfied that the manufacturer meets all of the requirements of the QAM Scheme, and that it is appropriate for the products being manufactured, LR will issue the manufacturer with a QAM Scheme Certificate which will list products covered.

6.3.5 LR reserves the right to carry out unscheduled audits, with appropriate notice, at the manufacturer's works or their suppliers' and sub-contractors' works.

6.3.6 Once every three years, a full re-certification assessment of QAM Scheme compliance, including an audit of the manufacturer's works, will be conducted by LR.

6.3.7 The manufacturer is to advise LR of changes to the product, processes, suppliers or subcontractors which would affect compliance with the QAM Scheme or LR's Rules. Any deviations from the approved plans or specifications are to be reported to LR and written approval obtained prior to dispatch of the items.

6.3.8 Where it is considered that the manufacturer no longer meets the approval requirements for the QAM Scheme, the QAM Scheme Certificate will be suspended. In these circumstances, the manufacturer will be notified in writing of LR's reasons for suspension of the scheme and the manufacturer will revert to direct survey and issue of LR certificates.

6.3.9 **QAM Scheme product certificates** Where the manufacturer is approved according to the QAM Scheme, they will be entitled to issue 'QAM Scheme product certificates'. These certificates are to clearly detail the product being certified and are to be validated by an authorised representative of the manufacturer. The certificates are to be countersigned by LR to certify that the Rule requirements for that product are being met.

6.4 Acceptance of purchased materials, components and equipment

6.4.1 The manufacturer is to establish and maintain procedures and controls to ensure compliance with LR's requirements for certification of products from its suppliers. The manufacturer is to ensure that purchased products that are required to be certified in accordance with *Ch 3 Rolled Steel Plates, Strip, Sections and Bars* to *Ch 10 Equipment for Mooring and Anchoring* of the Rules for Materials are made at works which have been approved by LR for the type and grade of product being supplied. The manufacturer's system for control of purchased products is to be based on one or a combination of the following alternatives:

- (a) Product certification by LR at the supplier's works in accordance with the requirements of the Rules.
- (b) Product certification by a supplier separately approved by LR under the QAM Scheme or other LR Quality Scheme covering those products.
- (c) Product certification by the manufacturer in accordance with quality processes for control of suppliers of purchased products included within the scope of the manufacturer's QAM Scheme approval. These quality schemes are to ensure compliance with Rule requirements for the purchased products.

6.4.2 Manufacturers' certificates issued under the QAM Scheme

Where the manufacturer's system for control of purchased products from suppliers is based on paragraph *Pt 5, Ch 1, 6.4 Acceptance of purchased materials, components and equipment 6.4.1* and Surveyors have confirmed that LR Rules are being satisfied, in lieu of LR Certificates for purchased products, the manufacturer will be permitted to accept 'Manufacturers' certificates issued under the QAM Scheme'. The certificates must bear the QAM Scheme mark and the following statement:

"This certificate is issued under the arrangements authorised by Lloyd's Register (operating entity, e.g. EMEA) in accordance with the requirements of the Quality Assurance Scheme for Machinery and Scheme number, QAM....."

■ Section 7

Spare gear for machinery installations

7.1 Application

7.1.1 Adequate spare parts for the propelling and essential auxiliary machinery, together with the necessary tools for maintenance and repair, are to be readily available for use.

7.1.2 The spare parts to be supplied and their location is to be the responsibility of the Owner, but they must take into account the design and arrangement of the machinery and the intended service and operation of the ship. Account must also be taken of the recommendations of the manufacturers and any applicable statutory requirement of the country of registration of the ship.

7.2 Guidance for spare parts

7.2.1 For general guidance purposes, spare parts for main and auxiliary machinery installations are shown in the LR's *Spare Gear Guidance* located on Class Direct.

Section

	Scope
1	Plans and particulars
2	Materials and Components
3	Design
4	Electronically controlled engines
5	Construction and welded structures
6	Turning gear
7	Control and monitoring of main, auxiliary and emergency engines
8	Piping
9	Starting arrangements
10	Safety arrangements
11	Factory Acceptance Test and Shipboard Trials of Internal Combustion Engines
12	Turbochargers
13	Air compressors
14	Type testing – General
	Cross-references

**Scope**

Engines providing power for services essential to the safety of the vessel are to be constructed under survey and in accordance with the requirements of this Chapter (see also *Pt 1, Ch 2, 2.4 Class notations (machinery) 2.4.1*).

The requirements of this Chapter are applicable to reciprocating internal combustion engines operating on liquid, gas or dual fuel for main propulsion and essential auxiliary services (hereinafter referred to as engines). *Pt 5, Ch 2, 3 Design* is not applicable to auxiliary engines having powers of less than 110 kW.

For the purposes of this Chapter engine type, expressed by the manufacturer/licensor's designation, is defined by:

- (a) the bore and stroke;
- (b) the method of injection (i.e. direct injection, indirect injection, pilot injection);
- (c) the fuel pump and injection system (independent line to fuel oil valve, common rail);
- (d) the valve and injection operation (by cams or electronically controlled);
- (e) the fuel(s) used (liquid, dual-fuel, gaseous, etc.);
- (f) the working cycle (4-stroke, 2-stroke);
- (g) the gas exchange (naturally aspirated, turbocharged, etc.);
- (h) the method of turbocharging (pulsating system, constant pressure system);
- (i) the charging air cooling system (with or without intercooler, number of stages);
- (j) cylinder arrangement (in-line, vee, etc.);
- (k) the maximum continuous power per cylinder (or maximum continuous brake mean effective pressure) at maximum continuous speed;
- (l) the manufacturer and type of governor (and control system if applicable) fitted.

A complete engine includes the control system, turbocharger(s) and all ancillary systems and equipment referred to in this Chapter that are used for operation of the engine for which there are rule requirements; this includes systems allowing the use of different fuel types.

Arrangements for dual fuel engines will be specially considered.

Primary exhaust gas emissions abatement plant (where fitted) is to meet the requirements of this Chapter; additionally, it is to meet the requirements of *Pt 5, Ch 24 Emissions Abatement Plant for Combustion Machinery*. Where secondary exhaust gas emissions abatement systems are fitted to engines, they are to meet the requirements of *Pt 5, Ch 24 Emissions Abatement Plant for Combustion Machinery*.

■ Section 1 Plans and particulars

1.1 Approval process

1.1.1 Approval of an engine type will be granted following:

- (a) satisfactory design appraisal
- (b) satisfactory type testing (see *Pt 5, Ch 2, 14.1 Engines*).

Note Approval of the engine type is not to be confused with LR Type Approval; LR Type Approval is explained in *Pt 1, Ch 2, 5.1 LR Type Approval – Marine Applications*.

1.1.2 Each complete engine, as defined in the scope, intended for installation on an LR Classed vessel, is to have an LR Engine Certificate.

1.1.3 For the first engine of a type the approval process and the engine certification process may be performed simultaneously.

1.1.4 To apply for an LR Engine Certificate, the following are to be submitted:

- (a) a list of all documents identified in the 'for information' and 'for appraisal' columns of *Table 2.1.1 Plans and particulars to be submitted for appraisal* with the relevant drawing numbers and revision status. This list is to cross-reference the approved plans previously submitted in accordance with *Pt 5, Ch 2, 1.1 Approval process 1.1.1* and identify any plans that have been modified.
- (b) where there is a licensor/licensee arrangement the list required by 1.1.4(a) is to cross-reference the drawings submitted by the designer in accordance with *Pt 5, Ch 2, 1.1 Approval process 1.1.1*. This list is to identify all changes where the approved design has been modified by the licensee. Where the licensee proposes design modifications to components, a statement is to be made confirming the licensor's acceptance of the proposed changes. If designer/licensor's acceptance is not confirmed, the engine is to be regarded as a different type and is subject to the complete appraisal and type testing process.
- (c) all documents with changes from the approved design are to be submitted for review/appraisal.

In all cases the complete set of endorsed documents and the list referenced in *Pt 5, Ch 2, 1.1 Approval process 1.1.4*, which are to be provided by the manufacturer, will be required by the Surveyor(s) attending the manufacturer's works. Where a licensee/licensor arrangement is in place, this set of documents may be a combination of licensor and licensee documents.

1.1.5 An LR Engine Certificate is issued upon satisfactory completion of engine assembly, with associated component testing (see *Pt 5, Ch 2, 2 Materials and Components*) and factory acceptance testing (see *Pt 5, Ch 2, 11 Factory Acceptance Test and Shipboard Trials of Internal Combustion Engines*). An alternative method of engine certification is available to manufacturers approved under the Quality Assurance Scheme for Machinery (QAM). See *Pt 5, Ch 1, 6 Quality Assurance Scheme for Machinery*.

1.1.6 For appraisal of emergency diesel-generators and turbochargers additional submissions are required. See *Pt 5, Ch 2, 1.2 Submission requirements 1.2.3* and *Pt 5, Ch 2, 1.2 Submission requirements 1.2.4* as applicable.

1.1.7 Where required Materials and Components are to be manufactured, tested and certified at a manufacturer approved by LR in accordance with the *Rules for the Manufacture, Testing and Certification of Materials* (hereinafter referred to as Rules for Materials), see *Pt 5, Ch 2, 2 Materials and Components*.

1.2 Submission requirements

Table 2.1.1 Plans and particulars to be submitted for appraisal

Document	For information (X indicates reason for submission)	For appraisal
Engine particulars (LR Form 2073 with general engine and ancillaries information, Project Guide, Marine Installation Manual) ¹	X	
Material specifications of principal components with information on non-destructive material tests and pressure tests		X
Engine cross-section	X	
Engine longitudinal section	X	
Engine frames, welding drawings ^{2,3}		X
Main engine foundation and holding down and securing arrangements	X (metal chocks)	X (non-metallic chocks)
Bedplate and crankcase of cast design	X	
Bedplate and crankcase of welded design, with welding details and welding instructions ^{2,3}		X
Bedplate/oil sump welding drawings ²		X
Thrust bearing assembly ⁴	X	
Thrust shaft or intermediate shaft (if integral with engine)		X
Thrust bearing bedplate of welded design, with welding details and welding instructions ²		X
Frame ³ , framebox ³ and gearcase of cast construction	X	
Tie rod	X	
Connecting rod, assembly ⁵	X	
Crosshead, assembly ⁵	X	
Piston rod, assembly ⁵	X	
Piston, assembly ⁵	X	
Piston head	X	
Cylinder jacket/ block of cast construction ³	X	
Cylinder cover, assembly ⁵	X	
Cylinder liner	X	
Counterweights (if not integral with crankshaft), including fastening	X	
Crankshaft, details (for each crankthrow)		X
Crankshaft, assembly (for each crankthrow)		X
Crankshaft calculations (see Pt 5, Ch 2, 3 Design)	X	
Camshaft drive, assembly ⁵	X	
Flywheel or turning-wheel	X	
Shaft coupling interface arrangement including dimensions and material details		X
Details of shielding and insulation of exhaust pipes and other parts operating at an elevated temperature, which might be impinged by flammable fluid(s) as a result of a system failure	X	

Schematic layout or other equivalent documents for the engine: ⁶		
• Starting and control air systems		X
• Fuel system		X
• Lubricating oil system		X
• Cooling water system		X
• Hydraulic systems		X
• Engine control and safety system		X
High pressure fuel injection pump assembly	X	
High pressure parts for fuel oil injection system ⁷		X
Shielding arrangements for high pressure piping - fuel, hydraulic & flammable oils (see Pt 5, Ch 2, 8.1 Fuel oil, hydraulic and high pressure oil systems 8.1.4)		X
Fastening arrangements for main bearings	X	
Fastening arrangements for cylinder heads and exhaust valve (two stroke design)	X	
Fastening arrangements for connecting rods	X	
Vibration dampers/detuners and moment compensators	X	
Construction and arrangement of vibration dampers	X	
Details of mechanical joints of piping systems		X
Oil mist detection and/or alternative arrangements		X
Construction of accumulators (common rail) for electronically controlled engine		X
Construction of common accumulators (common rail) for electronically controlled engine		X
Construction of accumulators for hydraulic oil and fuel oil		X
Arrangement and details of the crankcase explosion relief valve where applicable (see Pt 5, Ch 2, 10 Safety arrangements)		X
Calculation results for crankcase explosion relief valves (see Pt 5, Ch 2, 10 Safety arrangements)		X
Construction and arrangements of hydraulic systems for actuation of sub-systems:		
• Control valves, high-pressure pumps, pipes and accumulators	X	
• Drive for high pressure pumps	X	
• Valve bodies, if applicable	X	
For engine control, alarm monitoring and safety systems, the plans and information required by Pt 5, Ch 2, 1.2 Submission requirements 1.2.2 ⁸		X
Diesel generator test results that state the engine maximum load steps which satisfy the quality of power supply requirements specified in Pt 6, Ch 2, 1.7 Design and construction		X

Planned operating profiles for the vessel at sea and during manoeuvring as agreed with the Operators		X
List of sub-contractors for main parts	X	
Operation and service manuals ⁹	X	
Risk-based analysis (for engine control system) ¹⁰	X	
Test program resulting from risk-based analysis (for engine control system) ¹⁰	X	
Production specifications for castings and welding procedures	X	
Evidence of quality control system for engine design, production and in-service maintenance ^{5, 11}	X	
Type approval certification for environmental tests of control components ¹²	X	
Details of the engine type test program and the type test report ¹³		X
Engine test schedule (FAT & shipboard trials, see Pt 5, Ch 2, 1.2 Submission requirements 1.2.1)		X
Documentation verifying compliance with inclination limits (see Pt 5, Ch 1, 3.7 Inclination of ship)		X
Combustion pressure-displacement relationship		X

<p>Plans and details for dead ship condition starting arrangements, <i>see Pt 5, Ch 2, 9.1 Dead ship condition starting arrangements</i></p>	<p>X</p>
<p>Note 1. LR Form 2073 will be supplied on application. Note that the turbochargers, if required to be type approved, are to have plans and particulars submitted as detailed in <i>Pt 5, Ch 2, 1.2 Submission requirements 1.2.4.</i></p> <p>Note 2. For approval of materials and weld procedure specifications. The weld procedure specification is to include details of pre- and post-weld heat treatment, weld consumables and fit-up conditions.</p> <p>Note 3. For each cylinder for which dimensions and details differ.</p> <p>Note 4. If integral with engine and not integrated in the bedplate.</p> <p>Note 5. Including identification of components to ensure traceability in accordance with the Rules for Materials.</p> <p>Note 6. Details of the system so far as supplied by the engine manufacturer such as: main dimensions, operating media and maximum working pressures.</p> <p>Note 7. The documentation to contain specifications for pressures, pipe dimensions and materials.</p> <p>Note 8. The submission is to include a general overview of the operating principles, supported by schematics explaining the functionality of individual systems and sub-systems. The information is to relate to the engine capability and functionality under defined operating and emergency conditions such as recovery from a failure or malfunction, with particular reference to the functioning of programmable electronic systems and any sub-systems. The information is also to indicate if the engine has different modes of operation, such as to limit exhaust gas emissions and/or to run under an economic fuel consumption mode or any other mode that is electronically controlled.</p> <p>Note 9. Operational manuals are to contain maintenance requirements (servicing and repair) including details of any special tools and gauges that are to be used with their fitting/settings together with any test requirements on completion of maintenance. They are to include a description of each system's particulars and include reference to the functioning of sub-systems.</p> <p>Note 10. Where engines rely on hydraulic, pneumatic or electronic control of fuel injection and/or valves, the risk-based analysis is to address the mechanical, pressure containing, electrical, electronic and programmable electronic systems and arrangements that support the operation of the engine. It is to demonstrate that failure of the control system will not result in the operation of the engine being degraded beyond acceptable performance criteria for the engine and that suitable risk mitigation has been achieved in accordance with <i>Pt 5, Ch 2, 4.2 Risk-based analysis.</i> The risk-based analysis will not be explicitly approved by LR.</p> <p>Note 11. Including quality plan for sourcing, traceability, design, installation and testing of all components used in the fuel and hydraulic oil systems installed with the engine</p> <p>Note 12. Tests are to demonstrate the ability of the control, protection and safety equipment to function as intended under the specified testing conditions as per Lloyd's Register Type Approval Test Specification Number 1.</p> <p>Note 13. The type test report may be submitted shortly after the conclusion of the type test. For electronically controlled engines evidence of type testing of the engine with the programmable electronic system, or a proposed factory acceptance test plan at the engine builders with the programmable electronic system functioning, is to be submitted to verify the functionality and behaviour under normal operating and fault conditions of the programmable electronic control system.</p>	

1.2.1 A schedule of testing at engine builders, pre-sea trial commissioning and sea trials is to be submitted. The test schedules are to identify all modes of engine operation and the sea trials are to include typical port manoeuvres under the intended engine operating modes. The schedule is to include:

- (a) testing and trials to demonstrate that the engine is capable of operating as described in *Table 2.1.1 Plans and particulars to be submitted for appraisal*, Note 8;
- (b) tests to verify that the response of the complete mechanical, hydraulic, electrical and electronic system is as predicted for the intended operational modes; and
- (c) testing required to verify the conclusions of the risk-based analysis.

The scope of these tests is to be agreed with LR based on the risk-based analysis.

1.2.2 In addition to the applicable plans and particulars required by *Pt 6, Ch 1, 1.2 Documentation required for design review* the following information for control, alarm, monitoring and safety systems relating to the operation of an electronically controlled engine is to be submitted:

- (a) Engine configuration details, *see Pt 5, Ch 2, 4.3 Control engineering systems 4.3.2.*
 - (i) Local and remote means to carry out system configuration.

- (ii) Engine builder procedures for undertaking configuring.
- (iii) Roles and responsibilities for configuration (e.g. Engine builder, engine packager, system integrator or other nominated party) with accompanying schedule.
- (iv) Configurable settings and parameters (including those not to be modified from a default value).
- (v) Configuration for propulsion, auxiliary or emergency engine application.
- (b) Software quality plans, including configuration management documents.
- (c) Software safety evidence.
- (d) Software assessment inspection report.

Configuration records are to be maintained and are to be made available to the Surveyor at testing and trials and on request in accordance with *Pt 6, Ch 1, 1.1 General 1.1.4* and *Pt 6, Ch 1, 7.1 General 7.1.3*.

1.2.3 Emergency diesel-generator engine plans, information and test schedules, required for design appraisal, are to be in accordance with *Pt 6, Ch 1 Control Engineering Systems*.

1.2.4 For turbochargers, the following plans and particulars are to be submitted for information:

- (a) Cross-sectional drawing with principal dimensions and materials of housing components for containment evaluation.
- (b) Drawings of the housing and rotating parts including details of blade fixing.
- (c) Material specifications (chemical composition and mechanical properties) of all parts mentioned in (b) above including details of the material and quality control system to be used for these parts.
- (d) Welding details and welding procedure of above mentioned parts, if applicable.
- (e) Documentation of containment in the event of disc fracture, see *Pt 5, Ch 2, 12.5 Containment*.
- (f) Type test reports.
- (g) Operational data and limitations, i.e.:
 - Maximum permissible operating speed (rpm)
 - Alarm level for over-speed
 - Maximum permissible exhaust gas temperature before turbine
 - Alarm level for exhaust gas temperature before turbine
 - Minimum lubrication oil inlet pressure
 - Lubrication oil inlet pressure low alarm set point
 - Maximum lubrication oil outlet temperature
 - Lubrication oil outlet temperature high alarm set point
 - Maximum permissible vibration levels, i.e. self- and externally generated vibration (Alarm levels may be equal to permissible limits but are not to be reached when operating the engine at 110 per cent power or at any approved intermittent overload beyond 110 per cent.)
- (h) Arrangement of lubrication system, all variants within a range.
- (i) A list of main current suppliers and subcontractors for rotating parts and an operation and maintenance manual.
- (j) Documentation* of safe torque transmission when the disc is connected to the shaft by an interference fit, see *Pt 5, Ch 2, 12.6 Disk-Shaft shrinkage fit*.
- (k) Information on expected lifespan, considering creep, low cycle fatigue and high cycle fatigue.
- (l) Operation and maintenance manuals*. Note: * Applicable to two sizes in a generic range of turbochargers.

1.2.5 Where considered necessary Lloyd's Register (hereinafter referred to as 'LR') may require additional documentation to be submitted.

1.2.6 The following information is to be submitted to LR for acceptance of oil mist detection equipment and alarm arrangements:

- (a) Description of oil mist detection equipment and system including alarms.
- (b) Copy of the test house report in accordance with the requirements of Test Specification No. 4 See also *Pt 5, Ch 2, 14.4 Crankcase oil mist detection system*.
- (c) Schematic layout of engine oil mist detection arrangements showing location of detectors/sensors and piping arrangements and dimensions.
- (d) Maintenance and test manual which is to include the following information:
 - (i) Intended use of equipment and its operation;

- (ii) Functionality tests to demonstrate that the equipment is operational and that any faults can be identified and corrective actions notified;
- (iii) Maintenance routines and spare parts recommendations;
- (iv) Limit setting and instructions for safe limit levels; and
- (v) Where necessary, details of configurations in which the equipment is and is not to be used.

■ Section 2 Materials and Components

2.1 Crankshaft Materials

2.1.1 The specified minimum tensile strength of castings and forgings for crankshafts is to be selected within the following general limits:

- (a) Carbon and carbon-manganese steel castings –
400 to 550 N/mm²
- (b) Carbon and carbon-manganese steel forgings (normalised and tempered) -
400 to 600 N/mm²
- (c) Carbon and carbon-manganese steel forgings (quenched and tempered) -
not exceeding 700 N/mm²
- (d) Alloy steel castings -
not exceeding 700 N/mm²
- (e) Alloy steel forgings -
not exceeding 1000 N/mm²
- (f) Spheroidal or nodular graphite iron castings -
370 to 800 N/mm².

Table 2.2.1 Test and certification requirements for engine components

Part	Materials Tests				Component Tests		LR Component Certification
	Material Properties (1)	Surface Inspection (2)	Ultrasonic Inspection	LR Material Certification (3)	Hydraulic testing (5)	Visual inspection	
					(All Engines)		
Steel castings for welded bedplates	All	All	All	a	-	fit-up + post-welding	X
Steel forgings for welded bedplates	All	-	-	a	-	fit-up + post-welding	X
Plates for welded bedplates, frames and entablatures	All	-	-	a (4)	-	fit-up + post-welding	X
Bearing transverse girders	All	All	All	a	-	V	X

Reciprocating Internal Combustion Engines

Part 5, Chapter 2

Section 2

Crankcases, welded or cast	All	-	-	a (4)	-	V	X
Welded frame box	All	All	All	b (4)	-	fit-up + post-welding	X
Engine block	>400kW/ cylinder	-	-	a	1,5p	V	X
Cylinder block	All	-	-	a	1,5p	V	X
Welded cylinder frames	All	All	All	a (4)	-	fit-up + post-welding	X
Tie rod	All	Bore>400mm (6)	-	b	-	-	-
Bolts and studs for cylinder covers, crossheads, main bearings, tie rods and connecting rod bearings	Bore >300mm	Bore>400mm	Bore>400mm	c	-	V	-
Cylinder liner	Bore >300mm	-	-	a	7,0 bar	-	X
Cylinder cover	Bore >300mm	Bore>400mm	All see Note 17	a	7,0 bar see Note 7	V	X
Turbocharger, shaft & rotor	Bore >300mm			c	-	V	X
Turbocharger casing	(11)	(11)	(11)	c	G (8)	V	X
Crankshaft	All	All	All	a	-	V+D	X
Crankshaft coupling	Main propulsion	-	-	a	-	V+D	X
flange (non-integral)	bore>400mm	-	-	-	-	-	
Semi-built crankshaft (Crankthrow, forged main journal and journals with flange)	All	All	All	a	-	V+D	X
Connecting rod assembly	All	All	Bore >400mm	a	-	V+D	X
Crankshaft coupling bolts	Bore >400mm	Bore >400mm	Bore >400mm	c	-	V+D	X

Reciprocating Internal Combustion Engines

Part 5, Chapter 2

Section 2

Crosshead	Bore >400mm	Bore >400mm	Bore >400mm	a	-	V	X
Piston rod, if applicable	Bore >400mm	Bore >400mm	Bore >400mm	a	-	V	X
Piston crown (steel)	Bore >400mm	Bore >400mm	All	a	7,0 bar (7)	V	X
Steel gear wheels for camshaft drives	Bore >400mm	Bore >400mm	-	b	-	-	-
High pressure fuel injection system - valve, pipe, pump body (pressure side) (10)	All	-	-	a	Lesser of 1,5p or p +300 bar (9)	V	X
Coolers, both sides (12)	-	-	-	-	G	V	(13)
Accumulator of common rail fuel or servo oil system	Accumulators with a capacity >0,5 l	-	-	-	1,5p	-	X
Bearings for main, crosshead, and crankpin (14)	>800kW/cylinder	-	>800kW/cylinder	c	-	V+D	-
Piping, pumps, actuators, etc. for hydraulic systems, if applicable	All	-	All (Welds)	(15)	1,5p	V	(13)
Engine driven pumps - oil, water, fuel, bilge	-	-	-	(15)	G	-	X
Cylinder jacket cooling space (16)	-	-	-	-	G	-	-
Exhaust pipe cooling space	-	-	-	-	G	-	-
Exhaust valve cooling space	-	-	-	-	G	-	-

Air compressor inc. cylinders, covers, intercoolers & after coolers (12)	Calculated crankpin $\geq 50\text{mm}$	-	-	c	Air side: 1,5p Water side: G	-		X
<p>SYMBOLS:</p> <p>Bore dimensions refer to engine cylinder bores G = Pressure test at greater of 4,0 bar or 1,5p D = Dimensional inspection, including surface condition</p> <p>ρ = Max. working pressure of item concerned V = Visual examination of accessible surfaces X = LR Component Certification required by Surveyor (11)</p>								
<p>Note 1. Material properties include chemical composition and mechanical properties, and also surface treatment such as surface hardening (hardness, depth and extent), peening and rolling (extent and applied force). All required material tests are to be carried out in accordance with the relevant Chapters of the Rules for Materials.</p> <p>Note 2. Magnetic particle testing is to be carried out on Ferro-magnetic materials, liquid penetrant testing is only to be carried out on non-ferritic materials. Visual examination alone is not considered sufficient.</p> <p>Note 3. The certificate type required refers to the Rules for Materials <i>Ch 1, 3.1 General 3.1.3</i>.</p> <p>Note 4. Where welding is carried out, welding procedures and welder qualifications are to be carried out in accordance with the Rules for Materials <i>Ch 12 Welding Qualifications</i>.</p> <p>Note 5. Hydraulic testing is applied on the water/oil side of the component. The full lengths of cooling spaces are to be tested where applicable. Tests are to be witnessed by the Surveyor and an LR Test Certificate will be issued.</p> <p>Note 6. Magnetic particle testing of tie rods may be confined to the threaded portions and the adjacent material over a length equal to that of the thread.</p> <p>Note 7. For forged steel cylinder covers and piston crowns alternative testing methods may be specially considered. Where the piston rod seals the piston crown cooling space, it is to be tested after assembly.</p> <p>Note 8. Hydraulic testing of the cooling space. Turbocharger air coolers need only be tested on the water side.</p> <p>Note 9. Where components are subjected to an autofrettage process approved by LR, the component pressure test may be omitted. The assembled system containing such components is to be shown, where practicable, to be pressure-tight as required for hydraulic systems.</p> <p>Note 10. Pumps used in jerk or times pump systems need only have the assembled high pressure containing components hydraulically tested.</p> <p>Note 11. Dependent upon specific application.</p> <p>Note 12. Material and component certification for accumulators or coolers which are classed as pressure vessels are dependent on the operating pressure and temperature see <i>Pt 5, Ch 11, 1.5 Classification of fusion welded pressure vessels & Pt 5, Ch 11, 1.7 Materials</i>.</p> <p>Note 13. LR component certification required where the component is necessary for the operation of main propulsion or auxiliary engines which are the source of power for services essential for safety or for the operation of the ship at sea.</p> <p>Note 14. Ultrasonic testing required to prove full contact between basic material and bearing metal; only chemical properties required for materials testing.</p> <p>Note 15. Material certification requirements for pumps and piping components are dependent on the operating pressure and temperature, see <i>Pt 5, Ch 12, 1.5 Design temperature and Pt 5, Ch 12, 1.6 Classes of pipes</i>.</p> <p>Note 16. Where it is more practical to test the assembled engine (i.e. for engines with a multiple cylinder engine block), a leak test at working pressure may be accepted.</p> <p>Note 17. Cylinder covers manufactured from spheroidal or nodular graphite iron castings may not be suitable for ultrasonic NDE, depending upon the grain size and geometry. An alternative NDE procedure is to be agreed with LR.</p>								

2.1.2 Where it is proposed to use alloy castings, micro alloyed or alloy steel forgings or iron castings, details of the chemical composition, heat treatment and mechanical properties are to be submitted for approval.

2.2 Material test and inspections

2.2.1 Materials and components for engines are to be manufactured, tested and certified as indicated in *Table 2.2.1 Test and certification requirements for engine components* and in accordance with the relevant requirements of the Rules for Materials.

2.2.2 For components of novel design special consideration will be given to the acceptability of material properties and non-destructive testing requirements. For components and materials not specified in *Table 2.2.1 Test and certification requirements for engine components*, consideration will be given by LR upon submission and review of their full details.

2.2.3 With reference to *Table 2.2.1 Test and certification requirements for engine components*, certification is to be in accordance with Rules for Materials, *Ch 1, 3.1 General* and of the type as specified in *Table 2.2.1 Test and certification requirements for engine components*.

2.2.4 The certificate is to be in accordance with the Rules for Materials *Ch 1, 3.1 General 3.1.3* where the manufacturer or material supplier operates an approved LR Quality Scheme.

2.2.5 The manufacturer is not exempted from responsibility for any relevant tests and inspections of those parts for which documentation is not explicitly requested by LR.

2.3 Hydraulic tests

2.3.1 In general, items are to be tested by hydraulic pressure as indicated in *Table 2.2.1 Test and certification requirements for engine components*. Where design features are such that modifications to the test requirements shown in *Table 2.2.1 Test and certification requirements for engine components* are necessary, alternative proposals for hydraulic tests are to be submitted for special consideration.

2.3.2 Where a manufacturer has demonstrated to LR that they have an acceptable quality management system, a manufacturer's hydraulic test certificate may be accepted for engine driven pumps as detailed in *Table 2.2.1 Test and certification requirements for engine components*. Recognition and acceptance of the works quality control processes can be by one of the following routes:

- (a) Approval under the LR Quality Assurance Scheme for Machinery (QAM).
- (b) Approval of an alternative quality scheme recognised by LR.

2.4 Alignment gauges

2.4.1 All main and auxiliary oil engines exceeding 220 kW (300 shp) are to be provided with an alignment gauge which may be either a bridge wear-down gauge, or a micro-meter clock gauge for use between the crankwebs. Only one micrometer clock gauge need be supplied for each ship provided the gauge is suitable for use on all engines.

2.5 Autofrettage

2.5.1 Manufacturers who carry out autofrettage to enhance the fatigue life of components are to be approved by LR.

2.5.2 LR certificates are to be issued provided the attending Surveyors are satisfied that the required process parameters and associated QA processes have been applied.

■ **Section 3**
Design

3.1 Scope

3.1.1 The formulae given in this Section are applicable to solid, or semi-built crankshafts, having a main support bearing adjacent to each crankpin, and are intended to be applied to a single crankthrow analysed by the static determinate method.

3.1.2 Alternative methods, including a fully documented stress analysis, will be specially considered.

3.1.3 Calculations are to be carried out for the maximum continuous power rating for all intended operating conditions.

3.1.4 Designs of crankshafts not included in this scope will be subject to special consideration.

3.1.5 *Pt 5, Ch 2, 3 Design* is not applicable to auxiliary engines having powers of less than 110 kW.

3.2 Information to be submitted

3.2.1 In addition to detailed dimensioned plans, the following information is required to be submitted:

- Engine type — 4SCSA/2SCSA/in-line/vee.
- Output power at maximum continuous rating (MCR), in kW.
- Output speed at maximum continuous power, in rpm.
- Maximum cylinder pressure, in bar g.
- Mean indicated pressure, in bar g.
- Cylinder air inlet pressure, in bar g.
- Digitised gas pressure/crank angle cycle for MCR.
- Maximum pressure/speed relationship.
- Compression ratio.
- Vee angle and firing interval (if applicable), in degrees.
- Firing order numbered from driving end, see *Figure 2.3.1 Designation of cylinders*.
- Cylinder diameter, in mm.
- Piston stroke, in mm.
- Mass of connecting rod (including bearings), in kg.
- Centre of gravity of connecting rod from large end centre, in mm.
- Radius of gyration of connecting rod, in mm.
- Length of connecting rod between bearing centres, in mm.
- Mass of single crankweb (indicate if webs either side of pin are of different mass values), in kg.
- Centre of gravity of crankweb mass from shaft axis, in mm.
- Mass of counterweights fitted (for complete crankshaft) indicate positions fitted, in kg.
- Centre of gravity of counterweights (for complete crankshaft) measured from shaft axis, in mm.
- Mass of piston (including piston rod and crosshead where applicable), in kg.
- All individual reciprocating masses acting on one crank, in kg.
- Material specification(s).
- Specified minimum UTS, in N/mm².
- Specified minimum yield strength, in N/mm².
- Method of manufacture.
- Details of fatigue enhancement process (if applicable).
- For semi-built crankshafts — minimum and maximum diametral interference, in mm.

3.3 Symbols

3.3.1 For the purposes of this Chapter the following symbols apply, see also *Figure 2.3.2 Crank dimensions necessary for the calculation of stress concentration factors*:

h = radial thickness of web, in mm

k_e = bending stress factor

B = transverse breadth of web, in mm

D_p, D_j = outside diameter of pin or main journal, in mm

D_{pi}, D_{ji} = internal diameter of pin or main journal, in mm

D_s = shrink diameter of main journal in web, in mm

d_o = diameter of radial oil bore in crankpin, in mm

F = alternating force at the web centreline, in N

K_1 = fatigue enhancement factor due to manufacturing process

K_2 = fatigue enhancement factor due to surface treatment

M_b = alternating bending moment at web centreline, in N-mm (NOTE: alternating is taken to be ½ range value)

M_{BON} = alternating bending moment calculated at the outlet of crankpin oil bore

M_p, M_j = undercut of fillet radius into web measured from web face, in mm

R_p, R_j = fillet radius at junction of web and pin or journal, in mm

S = stroke, in mm

T = axial thickness of web, in mm

T_a = alternating torsional moment at crankpin or crank journal, in N-mm (NOTE: alternating is taken to be ½ range value)

U = pin overlap

$$= \frac{(D_p + D_j - S)}{2} \text{ mm}$$

α_B = bending stress concentration factor for crankpin

α_T = torsional stress concentration factor for crankpin

β_B = bending stress concentration factor for main journal

β_Q = direct shear stress concentration factor for main journal

β_T = torsional stress concentration factor for main journal

γ_B = bending stress concentration factor for radially drilled oil hole in the crankpin

γ_T = torsional stress concentration factor for radially drilled oil hole in the crankpin

σ_{ax} = alternating axial stress, in N/mm²

σ_b = alternating bending stress, in N/mm²

σ_{BON} = alternating bending stress in the outlet of the oil bore, in N/mm²

σ_p, σ_j = maximum bending stress in pin and main journal taking into account stress raisers, in N/mm²

σ_{BO} = maximum bending stress in the outlet of the oil bore, in N/mm²

σ_Q = alternating direct stress, in N/mm²

σ_u = specified minimum UTS of material, in N/mm²

σ_y = specified minimum yield stress of material, in N/mm²

τ_a = alternating torsional stress, in N/mm²

τ_p, τ_j = maximum torsional stress in pin and main journals taking into account stress raisers, in N/mm²

τ_{tob} = maximum torsional stress in outlet of crankpin oil bore taking into account stress raisers, in N/mm².

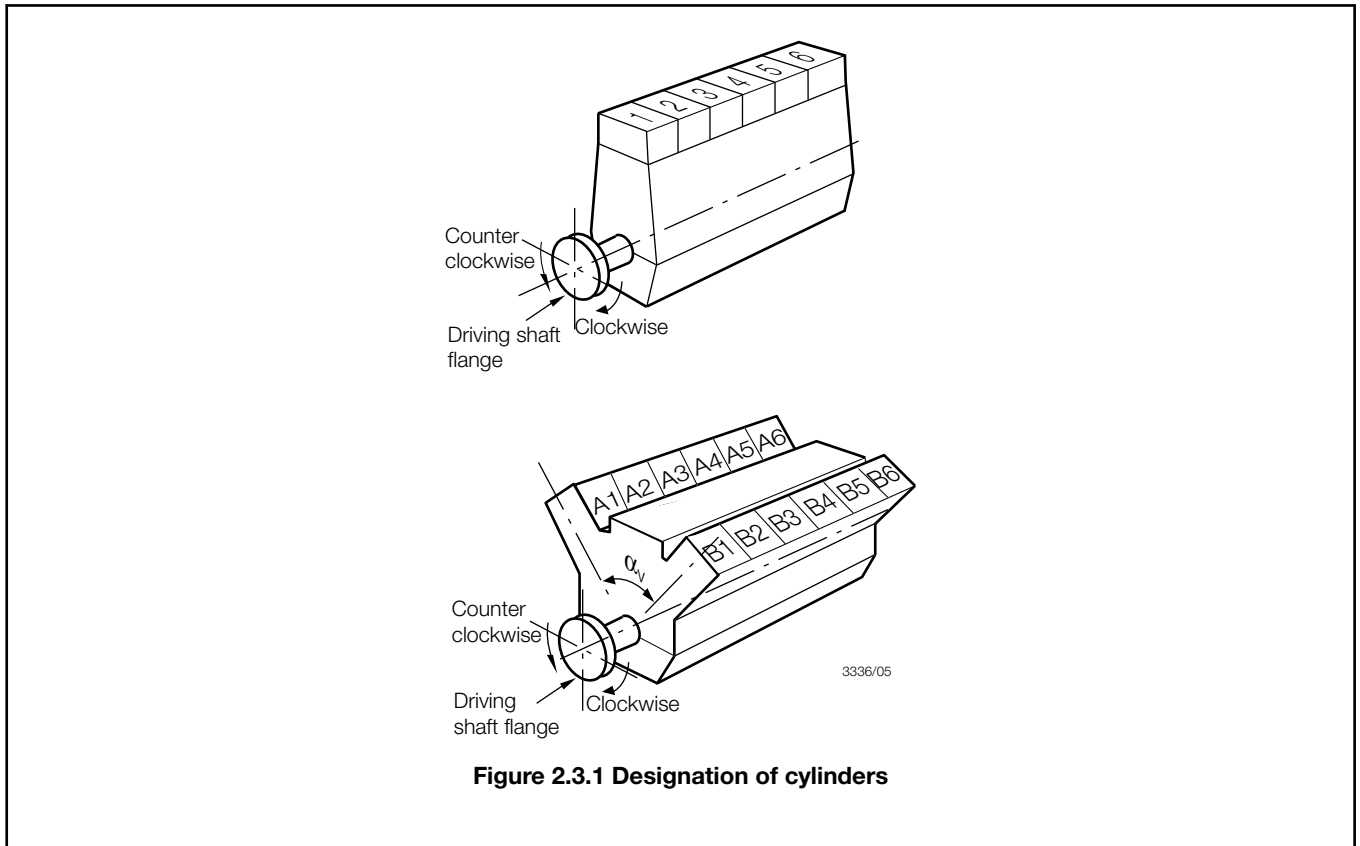

3.4 Stress concentration factors

3.4.1 **Geometric factors.** Crankshaft variables to be used in calculating the geometric stress concentrations together with their limits of applicability are shown in *Table 2.3.1 Crankshaft variables*.

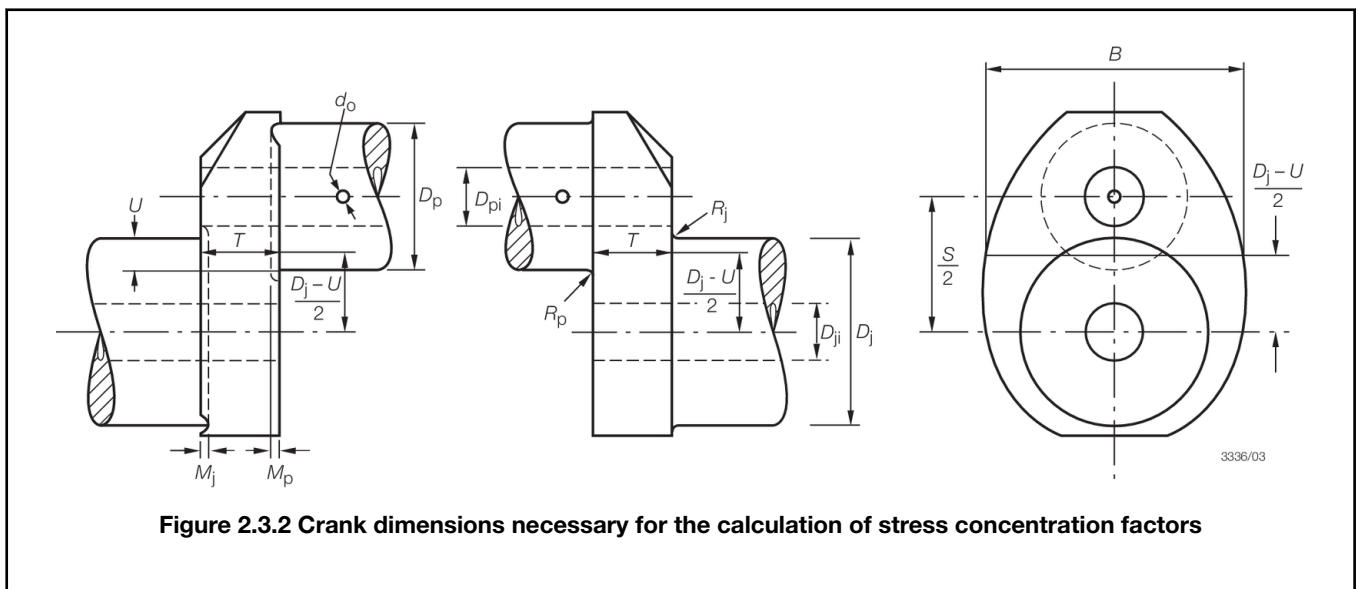

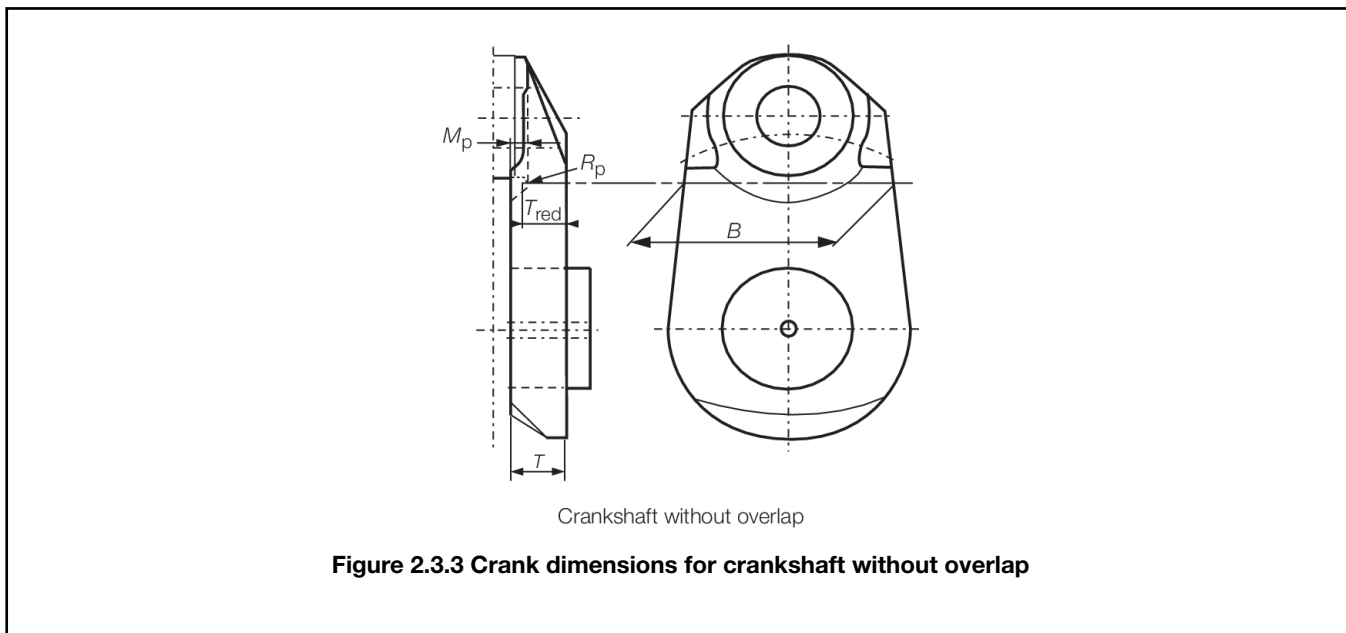

Figure 2.3.3 Crank dimensions for crankshaft without overlap

3.4.2 Crankpin stress concentration factors:

- Bending

$$\alpha_B = 2,70 f(ut) \cdot f(t) \cdot f(b) \cdot f(r) \cdot f(dp) \cdot f(dj) \cdot f(rec)$$

where

$$f(ut) = 1,52 - 4,1t + 11,2t^2 - 13,6t^3 + 6,07t^4 - u(1,86 - 8,26t + 18,2t^2 - 18,5t^3 + 6,93t^4) - u^2(3,84 - 25,0t + 70,6t^2 - 87,0t^3 + 39,2t^4)$$

$$f(t) = 2,18t^{0,717}$$

$$f(b) = 0,684 - 0,0077b + 0,147b^2$$

$$f(r) = 0,208r_p^{(-0,523)}$$

$$f(dp) = 1 + 0,315(d_p) - 1,52(d_p)^2 + 2,41(d_p)^3$$

$$f(dj) = 1 + 0,27d_j - 1,02(d_j)^2 + 0,531(d_j)^3$$

$$f(rec) = 1 + (m_p + m_j)(1,8 + 3,2u)$$

= valid only between $u = -0,5$ and $0,5$

- Torsion

$$\alpha_T = 0,8 f(ru) \cdot f(b) \cdot f(t)$$

where

$$f(ru) = r_p^{-(0,22 + 0,1u)}$$

$$f(b) = 7,9 - 10,65b + 5,35b^2 - 0,857b^3$$

$$f(t) = t^{(-0,145)}$$

3.4.3 Crank journal stress concentration factors (not applicable to semi-built crankshafts):

- Bending

$$\beta_B = 2,71 f_B(ut) \cdot f_B(t) \cdot f_B(b) \cdot f_B(r) \cdot f_B(dj) \cdot f_B(dp) \cdot f(rec)$$

where

$$f_B(u) = 1,2 - 0,5t + 0,32t^2 - u(0,80 - 1,15t + 0,55t^2) - u^2(2,16 - 2,33t + 1,26t^2)$$

$$f_B(t) = 2,24t^{0,755}$$

$$f_B(b) = 0,562 + 0,12b + 0,118b^2$$

$$f_B(r) = 0,191r_{jB}^{(-0,557)}$$

$$f_B(d_j) = 1 - 0,644d_j + 1,23(d_j)^2$$

$$f_B(dp) = 1 - 0,19d_p + 0,0073(d_p)^2$$

$$f(\text{rec}) = 1 + (m_p + m_j)(1,8 + 3,2u)$$

= valid only between $u = -0,5$ and $0,5$.

- Direct shear

$$\beta_Q = 3,01f_Q(u) \cdot f_Q(t) \cdot f_Q(b) \cdot f_Q(r) \cdot f_Q(dp) \cdot f(\text{rec})$$

where

$$f_Q(u) = 1,08 + 0,88u - 1,52u^2$$

$$f_Q(t) = \frac{t}{0,0637 + 0,937t}$$

$$f_Q(b) = b - 0,5$$

$$f_Q(r) = 0,533r_{jB}^{(-0,204)}$$

$$f_Q(dp) = 1 - 1,19d_p + 1,74(d_p)^2$$

$$f(\text{rec}) = 1 + (m_p + m_j)(1,8 + 3,2u)$$

= valid only between $u = -0,5$ and $0,5$.

- Torsion

where

$$\beta_T = 0,8f(ru) \cdot f(b) \cdot f(t)$$

$$f(ru) = r_{jT}^{-(0,22 + 0,1u)}$$

$$f(b) = 7,9 - 10,65b + 5,35b^2 - 0,857b^3$$

$$f(t) = t^{(-0,145)}$$

Table 2.3.1 Crankshaft variables

Variable	Range	
	Lower	Upper
$b = B/D_p$	1,10	2,20
$d_j = \frac{D_{j\pi}}{D_p}$	0,00	0,80
$d_p = \frac{D_{pi}}{D_p}$	0,00	0,80

$m_j = M_j/D_p$	0,00	r_{jB}
$m_p = M_p/D_p$	0,00	r_p
$r_{jB} = R_j/D_p$	0,03	0,13
$r_{jT} = R_j/D_j$	0,03	0,13
$r_p = R_p/D_p$	0,03	0,13
$t = T/D_p$	0,20	0,80
$t = T_{red}/D_p$ see Note 3	0,20	0,80
$d = d_o/D_p$	0,00	0,20
$u = U/D_p$ see Note 2		0,50
<p>Note 1 Where variables fall outside the range, alternative methods are to be used and full details submitted for consideration.</p> <p>Note 2 A lower limit of u can be extended down to large negative values provided that: (i) If calculated $f(\text{rec}) < 1$ then the factor $f(\text{rec})$ is not to be considered ($f(\text{rec}) = 1$) (ii) If $u < -0,5$ then $f(\text{ut})$ and $f(\text{ru})$ are to be evaluated replacing actual value of u by $-0,5$.</p> <p>Note 3. For crankshafts without overlap see also Pt 5, Ch 2, 3.4 Stress concentration factors 3.4.6.</p>		

3.4.4 Crankpin oil bore stress concentration factors for radially drilled oil holes:

- Bending

$$\gamma_B = 3 - 5,88 \cdot \frac{d_o}{D_p} + 34,6 \cdot \left(\frac{d_o}{D_p}\right)^2$$

- Torsion

$$\gamma_T = 4 - 6 \cdot \frac{d_o}{D_p} + 30 \cdot \left(\frac{d_o}{D_p}\right)^2$$

3.4.5 Where experimental measurements of the stress concentrations are available these may be used. The full documented analysis of the experimental measurements is to be submitted for consideration.

3.4.6 In the case of semi-built crankshafts when $M_p > R_p$ the web thickness is to be taken as:

$T_{red} = T - (M_p - R_p)$ and the web width B is to be taken in way of the crankpin fillet radius centre see *Figure 2.3.2 Crank dimensions necessary for the calculation of stress concentration factors.*

3.5 Nominal stresses

3.5.1 The nominal alternating bending stress, σ_b , is to be calculated from the maximum and minimum bending moment at the web centreline taking into account all forces being applied to the crank throw in one working cycle with the crank throw simply supported at the mid length of the main journals.

3.5.2 Nominal bending stresses are referred to the web bending modulus.

3.5.3 Nominal alternating bending stress:

$$\sigma_b = \pm \frac{M_b}{Z_{web}} k_e \text{ N/mm}^2$$

$$Z_{web} = \frac{BT^2}{6} \text{ mm}^3$$

$$k_e = 0,8 \text{ for crosshead engines}$$

$$= 1,0 \text{ for trunk piston engines.}$$

3.5.4 Nominal alternating bending stress in the outlet of the crankpin oil bore:

$$\sigma_{BON} = \pm \frac{M_{BON}}{Z_{crankpin}}$$

where

M_{BON} is taken as the $\frac{1}{2}$ range value $M_{BON} = \pm \frac{1}{2} (M_{BOmax} - M_{BOmin})$

and

$$M_{BO} = (M_{BTO} \cos\psi + M_{BRO} \sin\psi), \text{ see Figure 2.3.4 Crankpin section through the oil bore}$$

The two relevant bending moments are taken in the crankpin cross-section through the oil bore.

M_{BRO} = bending moment of the radial component of the connecting-rod force

M_{BTO} = bending moment of the tangential component of the connecting-rod force

$$Z_{crankpin} = \frac{\pi}{32} \frac{D^4 - d^4}{D} Z_{crankpin} \text{ related to the cross-section of axially bored crankpin.}$$

3.5.5 The nominal direct shear stress in the web for the purpose of assessing the main journal is to be added algebraically to the bending stress, using the alternating forces which have been used in deriving M_b in *Pt 5, Ch 2, 3.5 Nominal stresses 3.5.3.*

3.5.6 Nominal stress is referred to the web cross-section area or the pin cross-section area as applicable.

3.5.7 Nominal alternating direct shear stress:

$$\sigma_Q = \pm \frac{F}{A_{web}} k_e \text{ N/mm}^2.$$

where

$$A_{web} = BT \text{ mm}^2$$

3.5.8 The nominal alternating torsional stress, τ_a , is to be taken into consideration. The value is to be derived from forced-damped vibration calculations of the complete dynamic system. Alternative methods will be given consideration. The engine designer is to advise the maximum level of alternating vibratory stress that is permitted.

3.5.9 The results of torsional vibration calculations for the full dynamic system, carried out in accordance with *Pt 5, Ch 8, 2.2 Particulars to be submitted*, are to be submitted.

3.5.10 Nominal alternating torsional stress:

$$\tau_a = \pm \frac{T_a}{Z_T} \text{ N/mm}^2$$

where

Z_T = torsional modulus of crankpin and main journal

$$= \frac{\pi}{16} \left[\frac{(D^4 - d^4)}{D} \right] \text{ mm}^3$$

D = outside diameter of crankpin or main journal, in mm

d = inside diameter of crankpin or main journal, in mm

τ_a is to be ascertained from assessment of the torsional vibration calculations where the maximum and minimum torques are determined for every mass point of the complete dynamic system and for the entire speed range by means of a harmonic synthesis of the forced vibrations from the 1st order up to and including the 15th order for 2-stroke cycle engines and from the 0,5th order up to and including the 12th order for 4-stroke cycle engines. Whilst doing so, allowance must be made for the damping that exists in the system and for unfavourable conditions (misfiring in one of the cylinders when no combustion occurs but only compression cycle). The speed step calculation shall be selected in such a way that any resonance found in the operational speed range of the engine shall be detected.

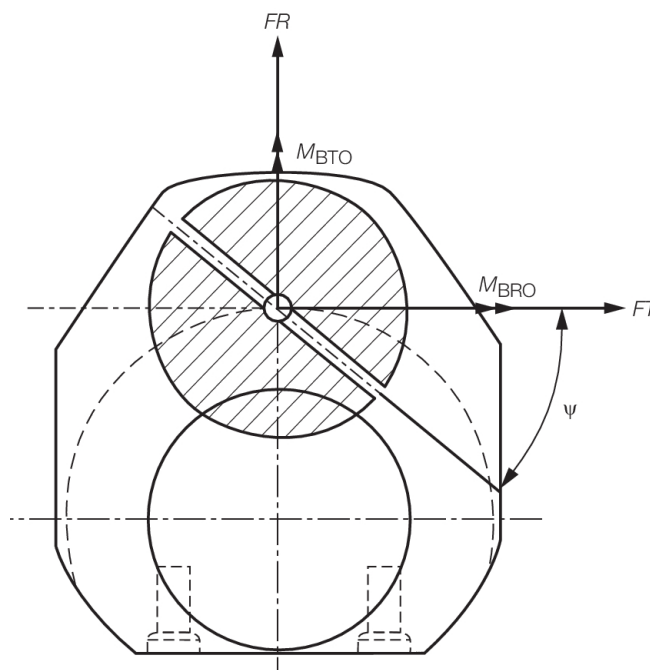

Figure 2.3.4 Crankpin section through the oil bore

3.5.11 For the purpose of the crankshaft assessment, the nominal alternating torsional stress considered in calculations is to be the highest calculated value, according to the method described in Pt 5, Ch 2, 3.5 Nominal stresses 3.5.9, occurring at the most torsionally loaded mass point of the crankshaft system.

3.5.12 The approval of the crankshaft will be based on the installation having the largest nominal alternating torsional stress (but not exceeding the maximum figure specified by the engine manufacturer). For each installation it is to be ensured by calculation that the maximum approved nominal alternating torsional stress is not exceeded.

3.5.13 In addition to the bending stress, σ_b , the axial vibratory stress, σ_{ax} , is to be taken into consideration, for crosshead type engines. For trunk type engines, $\sigma_{ax} = 0$. The value is to be derived from forced-damped vibration calculations of the complete

dynamic system. Alternative methods will be given consideration. The engine designer is to advise the maximum level of alternating vibratory stress that is permitted. The corresponding crankshaft free-end deflection is also to be stated.

3.6 Maximum stress levels

3.6.1 Crankpin fillet.

- Maximum alternating bending stress:

$$\sigma_p = \alpha_B (\sigma_b + \sigma_{ax}) \text{ N/mm}^2$$

where

α_B = bending stress concentration, see Pt 5, Ch 2, 3.4 Stress concentration factors 3.4.2

- Maximum alternating torsional stress:

$$\tau_p = \alpha_T \tau_a \text{ N/mm}^2$$

where

α_T = torsional stress concentration, see Pt 5, Ch 2, 3.4 Stress concentration factors 3.4.2

τ_a = nominal alternating torsional stress in crankpin N/mm²

3.6.2 Outlet of crankpin oil bore

- Maximum alternating bending stress:

$$\sigma_{BO} = \gamma_B (\sigma_{BON} + \sigma_{ax}) \text{ N/mm}^2$$

where

γ_B = bending stress concentration factor, see Pt 5, Ch 2, 3.4 Stress concentration factors 3.4.4

- Maximum alternating torsional stress:

$$\tau_{tob} = \gamma_T \tau_a \text{ N/mm}^2$$

where

γ_T = torsional stress concentration factor, see Pt 5, Ch 2, 3.4 Stress concentration factors 3.4.4

τ_a = nominal alternating torsional stress in crankpin N/mm².

3.6.3 Crank journal fillet (not applicable to semi-built crankshafts).

- Maximum alternating bending stress:

$$\sigma_j = \beta_B (\sigma_b + \sigma_{ax}) + \beta_Q \sigma_Q \text{ N/mm}^2$$

where

β_B = bending stress concentration, see Pt 5, Ch 2, 3.4 Stress concentration factors 3.4.3

β_Q = direct stress concentration, see Pt 5, Ch 2, 3.4 Stress concentration factors 3.4.3

- Maximum alternating torsional stress:

$$\tau_j = \beta_T \tau_a \text{ N/mm}^2$$

where

β_T = torsional stress concentration, see Pt 5, Ch 2, 3.4 Stress concentration factors 3.4.3

τ_a = nominal alternating torsional stress in main journal N/mm².

3.7 Equivalent alternating stress

3.7.1 Equivalent alternating stress of the crankpin, σ_{ep} , or crank journal σ_{ej} , is defined as:

$$\sigma_{ep}, \sigma_{ej} = \sqrt{(\sigma + 10)^2 + 3\tau^2} \text{ N/mm}^2$$

where

$$\sigma = \sigma_p \text{ or } \sigma_j \text{ N/mm}^2$$

$$\tau = \tau_p \text{ or } \tau_j \text{ N/mm}^2.$$

3.7.2 Equivalent alternating stress for the outlet of the crankpin oil bore σ_{eob} , is defined as:

$$\sigma_{eob} = \pm \frac{1}{3} \sigma_{bo} \left[1 + 2\sqrt{1 + \frac{9}{4} \left(\frac{\tau_{to}}{\sigma_{bo}} \right)^2} \right] \text{ N/mm}^2$$

3.8 Fatigue strength

3.8.1 The fatigue strength of a crankshaft is based upon the crankpin and crank journal as follows:

$$\sigma_{fp} = K_1 K_2 (0,42 \sigma_u + 39,3) \left(0,264 + 1,073 D_p^{-0,2} + \frac{785 - \sigma_u}{4900} + \frac{196}{\sigma_u} \sqrt{\frac{1}{R_p}} \right)$$

To calculate the fatigue strength in the oil bore area, replace R_p with $\frac{1}{2}d_o$ and σ_{fp} with σ_{fob} .

$$\sigma_{fj} = K_1 K_2 (0,42 \sigma_u + 39,3) \left(0,264 + 1,073 D_j^{-0,2} + \frac{785 - \sigma_u}{4900} + \frac{196}{\sigma_u} \sqrt{\frac{1}{R_j}} \right)$$

where

σ_u = UTS of crankpin or crank journal as appropriate

K_1 = fatigue endurance factor appropriate to the manufacturing process

= 1,05 for continuous grain-flow (CGF) or die-forged

= 1,0 for freeform forged (without CGF)

= 0,93 for cast steel manufactured using a LR approved cold rolling process

K_2 = fatigue enhancement factor for surface treatment.

These treatments are to be applied to the fillet radii

A value for K_2 will be assigned upon application by the engine designers. Full details of the process, together with the results of full scale fatigue tests will be required to be submitted for consideration. Alternatively, the following values may be taken (surface hardened zone to include fillet radii):

$K_2 = 1,15$ for induction hardened

= 1,25 for nitrided

Where a value of K_1 or K_2 greater than unity is to be applied then details of the manufacturing process are to be submitted.

3.9 Acceptability criteria

3.9.1 The acceptability factor, Q , is to be greater than 1,15:

$$Q = \frac{\sigma_f}{\sigma_e} \text{ for crankpin, journal and the outlet of crankpin oil bore}$$

where

$$\sigma_f = \sigma_{fp} \text{ OR } \sigma_{fj} \text{ OR } \sigma_{fob}$$

$$\sigma_e = \sigma_{ep} \text{ OR } \sigma_{ej} \text{ OR } \sigma_{eob}$$

3.10 Oil hole

3.10.1 The junction of the oil hole with the crankpin or main journal surface is to be formed with an adequate radius and smooth surface finish down to a minimum depth equal to 1,5 times the oil bore diameter.

3.10.2 Fatigue strength calculations or alternatively fatigue test results may be required to demonstrate acceptability.

3.10.3 When journal diameter is equal or larger than the crankpin diameter, the outlets of main journal oil bores are to be formed in a similar way to the crankpin oil bores, otherwise separate fatigue strength calculations or, alternatively, fatigue test results may be required.

3.11 Shrink fit of semi-built crankshafts

3.11.1 The maximum permissible internal diameter in the journal pin is to be calculated in accordance with the following formula:

$$D_{ji} = D_s \sqrt{1 - \frac{4000 F_o S M_{\max}}{\mu \pi D_s^2 L_s \sigma_{yj}}}$$

where the symbols are as defined in Pt 5, Ch 2, 3.11 Shrink fit of semi-built crankshafts 3.11.7.

3.11.2 When Pt 5, Ch 2, 3.11 Shrink fit of semi-built crankshafts 3.11.1 cannot be complied with, then Pt 5, Ch 2, 3.11 Shrink fit of semi-built crankshafts 3.11.7 is not applicable. In such cases δ_{min} and δ_{max} are to be established from FEM calculations.

3.11.3 The following formulae are applicable to crankshafts assembled by shrinking main journals into the crankwebs.

3.11.4 In general, the radius of transition, R_j , between the main journal diameter, D_j , and the shrink diameter, D_s , is to be not less than $0,015D_j$ or $0,5(D_s - D_j)$.

3.11.5 The distance, y , between the underside of the pin and the shrink diameter should be greater than $0,05D_s$.

3.11.6 Deviations from these parameters will be specially considered.

3.11.7 The proposed diametral interference is to be within the following limits, see also Figure 2.3.5 Crank throw of semi-built crankshaft:

The minimum required diametral interference is to be taken as the greater of:

$$\delta_{\min} = \frac{12,156 \times 10^6 (FoS) P}{TD_s \mu E} \frac{1}{R} (1 + C) \frac{k^2 - l^2}{(k^2 - 1)(1 - l^2)} \text{ mm}$$

or

$$\delta_{\min} = \frac{\sigma_y D_s}{E} \text{ mm}$$

where

h = minimum radial thickness of the web around the diameter D_s , mm

$$k = \frac{D_o}{D_s}$$

$$l = \frac{D_{ji}}{D_s}$$

C = ratio of torsional vibratory torque to the mean transmitted torque at the P/R rating being considered

D_o = $D_s + 2h$, in mm

D_s = shrink diameter, in mm

where

E = Young's modulus of elasticity of crankshaft material, in N/mm²

FoS = Factor of Safety against rotational slippage to be taken as 2,0. A value less than 2,0 may be used where documented by experiments to demonstrate acceptability

P = output power, in kW

R = speed at associated power, in rpm

T = crankweb thickness, in mm

μ = coefficient of static friction to be taken as 0,2 for degreased surfaces. A value greater than 0,2 may be used where documented by experiments to demonstrate acceptability

σ_{yj} = minimum yield strength of material for journal pin

M_{max} = absolute maximum value of the torque taking *Pt 5, Ch 8, 2 Torsional vibration* into consideration

L_s = length of shrink fit, in mm

= Maximum diametral interference, δ_{max} , is not to be greater than:

$$\delta_{max} = \frac{\sigma_y D_s}{E} + \frac{0,8 D_s}{1000} \text{ mm.}$$

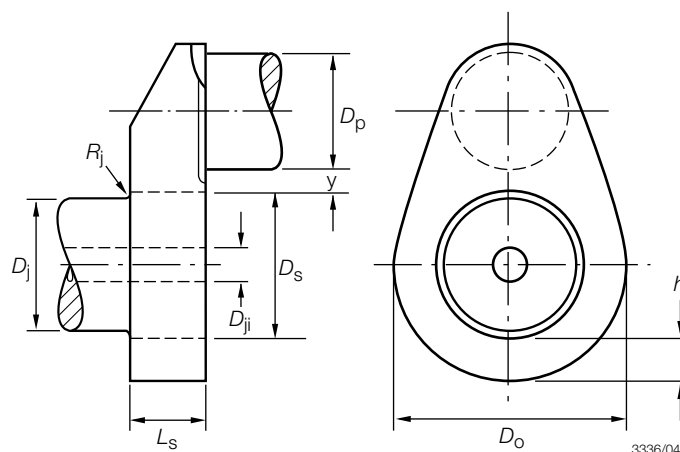

Figure 2.3.5 Crank throw of semi-built crankshaft

3.11.8 Reference marks are to be provided on the outer junction of the crankwebs with the journals.

3.12 Alternative method for calculation of stress concentration factors

3.12.1 LR will give consideration to crankshaft design using an alternative method given in LR's *ShipRight procedures for alternative method for calculation of stress concentration factors in the web fillet radii of crankshafts by utilising Finite Element*.

■ Section 4 Electronically controlled engines

4.1 General

4.1.1 The requirements of this Section are applicable to engines for propulsion, auxiliary or emergency power purposes with programmable electronic systems implemented and used to control fuel injection timing and duration, and which may also control combustion air or exhaust systems. The requirements of this Section also apply to programmable electronic systems used to control other functions (e.g. starting and control air, cylinder lubrication etc.) where essential for the operation of the engine.

4.1.2 These engines may be of the crosshead or trunk piston type. They generally have no direct camshaft driven fuel systems, but have common rail fuel/hydraulic arrangements and may have hydraulic actuating systems for the functioning of the exhaust systems.

4.1.3 The operation of these engines relies on the effective monitoring of a number of parameters such as crank angle, engine speed, temperatures and pressures using programmable electronic systems to provide the services essential for the operation of the engine such as fuel injection, air inlet, exhaust and speed control.

4.1.4 Details of proposals to deviate from the requirements of this Section are to be submitted and will be considered on the basis of a technical justification produced by the Enginebuilder.

4.1.5 Each engine is to be configured for the specified performance and is to satisfy the relevant requirements for propulsion, auxiliary or emergency engines.

4.1.6 During the life of the engine details, of any proposed changes to control, alarm, monitoring or safety systems which may affect safety and the reliable operation of the engine are to be submitted to LR for approval.

4.2 Risk-based analysis

4.2.1 An analysis is to be carried out in accordance with relevant standards acceptable to LR to demonstrate compliance with the applicable requirements of this sub-Section appropriate to the engine application. The analysis is to be a risk-based consideration of engine operation and ship and personnel safety, and is to demonstrate adequate risk mitigation through fault tolerance and/or reliability in accordance with the specified criteria in *Pt 5, Ch 2, 4.2 Risk-based analysis 4.2.2 to Pt 5, Ch 2, 4.2 Risk-based analysis 4.2.4* relevant to the engine application.

4.2.2 For ships with a single main propulsion engine, a Failure Mode and Effects Analysis (FMEA), or alternative recognised analysis of system reliability, is to be carried out and is to demonstrate that an electronic control system failure:

- (a) will not result in the loss of the ability to provide the services essential for the operation of the engine, see *Pt 6, Ch 1, 2.5 Control systems, general requirements 2.5.7* and *Pt 6, Ch 1, 2.13 Programmable electronic systems - Additional requirements for essential services and safety critical systems 2.13.2*;
- (b) will not affect the normal operation of the services essential for the operation of the engine other than those services dependent upon the failed part, see *Pt 6, Ch 1, 2.14 Programmable electronic systems - Additional requirements for integrated systems 2.14.4* and *Pt 6, Ch 1, 2.14 Programmable electronic systems - Additional requirements for integrated systems 2.14.5*; and
- (c) will not leave either the engine, or any equipment or machinery associated with the engine, or the ship in an unsafe condition, see *Pt 6, Ch 1, 2.3 Alarm systems, general requirements 2.3.13*, *Pt 6, Ch 1, 2.4 Safety systems, general requirements 2.4.5*, *Pt 6, Ch 1, 2.5 Control systems, general requirements 2.5.3*, *Pt 6, Ch 1, 2.10 Programmable electronic systems - General requirements 2.10.3*, *Pt 6, Ch 1, 2.10 Programmable electronic systems - General requirements 2.10.4* and *Pt 6, Ch 1, 2.14 Programmable electronic systems - Additional requirements for integrated systems 2.14.5*.

4.2.3 A risk-based analysis is to be carried out for:

- (a) main engines on ships with multiple main engines or other means of providing propulsion power; and/or
- (b) auxiliary engines intended to drive electric generators forming the ship's main source of electrical power or otherwise providing power for essential services.

The analysis is to demonstrate that adequate hazard mitigation has been incorporated in electronically controlled engine systems or the overall ship installation with respect to personnel safety and providing propulsion power and/or power for essential services for the safety of the ship. Arrangements satisfying the criteria of *Pt 5, Ch 2, 4.2 Risk-based analysis 4.2.2 to Pt 5, Ch 2, 4.2 Risk-based analysis 4.2.2* will also be acceptable.

4.2.4 For engines for emergency power purposes, a risk-based analysis is to be carried out to demonstrate that the design incorporates adequate hazard mitigation such that the likelihood of an electronic control system failure resulting in the loss of the ability to provide emergency power when required has been reduced to a level considered acceptable by LR and that means are provided to detect failures and permit personnel to restore engine availability to operate on demand. Failures which would result in engine failure and/or damage or loss of availability are to be identified and the report is to include documentation of:

- (a) component reliability evidence;
- (b) failure detection and alarms; and
- (c) failure response required to restore engine availability and maintain personnel safety.

4.2.5 The risk-based analysis report is to:

- (a) Identify the standards used for analysis and system design.
- (b) Identify the engine, its purpose and the associated objectives of the analysis.
- (c) Identify any assumptions made in the analysis.
- (d) Identify the equipment, system or sub-system, mode of operation and the equipment.
- (e) Identify potential failure modes and their causes.
- (f) Evaluate the local effects (e.g. fuel injection failure) and the effects on the system as a whole (e.g. loss of propulsion power) of each failure mode.
- (g) Identify measures for reducing the risks associated with each failure mode (e.g. system design, failure detection and alarms, redundancy, quality control procedures for sourcing, manufacture and testing, etc.).
- (h) Identify trials and testing necessary to prove conclusions.

4.2.6 At sub-system level it is acceptable to consider failure of equipment items and their functions, e.g. failure of a pump to produce flow or pressure head. It is not required that the failure of components within that pump be analysed, and failure need only be dealt with as a cause of failure of the pump.

4.3 Control engineering systems

4.3.1 Control, alarm, monitoring, safety and programmable electronic systems are to comply with *Pt 6, Ch 1 Control Engineering Systems* as applicable.

4.3.2 The engine control, alarm monitoring and safety systems are to be configured to comply with the relevant requirements (e.g. operating profile, alarms, shutdowns, etc.) of this Chapter and *Pt 6, Ch 1 Control Engineering Systems* for an engine for main, auxiliary or emergency power purposes. Details of the engine configuration are to be submitted for consideration, see *Pt 5, Ch 2, 1.2 Submission requirements 1.2.2*.

4.4 Software

4.4.1 Software lifecycle activities are to be carried out in accordance with an acceptable quality management system, see *Pt 6, Ch 1, 2.13 Programmable electronic systems - Additional requirements for essential services and safety critical systems 2.13.2* and *Pt 6, Ch 1, 2.13 Programmable electronic systems - Additional requirements for essential services and safety critical systems 2.13.7*.

4.4.2 Appropriate safety related processes, methods, techniques and tools are to be applied to software development and maintenance by the Enginebuilder. Selection and application of techniques and measures in accordance with Annex A of IEC 61508-3, *Functional safety of electrical/electronic/programmable electronic systems: Software requirements*, or other relevant standards or codes acceptable to LR, will generally be acceptable.

4.4.3 To demonstrate compliance with *Pt 5, Ch 2, 4.4 Software 4.4.1* and *Pt 5, Ch 2, 4.4 Software 4.4.2*:

- (a) software quality plans and safety evidence are to be submitted for consideration, see *Pt 5, Ch 2, 1.2 Submission requirements 1.2.2*; and
- (b) an assessment inspection of the Enginebuilder's completed development is to be carried out by LR. The inspection is to be tailored to verify application of the standards and codes used in software safety assurance accepted by LR.

■ Section 5 Construction and welded structures

5.1 Crankcases

5.1.1 Crankcases and their doors are to be of robust construction to withstand anticipated crankcase pressures that may arise during a crankcase explosion, taking into account the installation of explosion relief valves required by *Pt 5, Ch 2, 6 Turning gear* and the doors are to be securely fastened so that they will not be readily displaced by a crankcase explosion.

5.2 Welded joints

5.2.1 Bedplates and major components of engine structures are to be made with a minimum number of welded joints.

5.2.2 Double welded butt joints are to be adopted wherever possible in view of their superior fatigue strength.

5.2.3 Girder and frame assemblies should, so far as possible, be made from one plate or slab, shaped as necessary, rather than by welding together a number of small pieces.

5.2.4 Steel castings are to be used for parts which would otherwise require complicated weldments.

5.2.5 Care is to be taken to avoid stress concentrations such as sharp corners and abrupt changes in section.

5.2.6 Joints in parts of the engine structure which are stressed by the main gas or inertia loads are to be designed as continuous full strength welds and for complete fusion of the joint. They are to be so arranged that, in general, welds do not intersect, and that welding can be effected without difficulty and adequate inspection can be carried out. Abrupt changes in plate section are to be avoided and where plates of substantially unequal thickness are to be butt welded, the thickness of the heavier plate is to be gradually tapered to that of the thinner plate. Tee joints are to be made with full bevel or equivalent weld preparation to ensure full penetration.

5.2.7 In single plate transverse girders the castings for main bearing housings are to be formed with web extensions which can be butt welded to the flange and vertical web plates of the girder. Stiffeners in the transverse girder are to be attached to the flanges by full penetration welds.

5.3 Materials and construction

5.3.1 Plates, sections, forgings and castings are to be of welding quality in accordance with the requirements of the *Rules for the Manufacture, Testing and Certification of Materials, July 2015*, and with a carbon content generally not exceeding 0,23 per cent. Steels with higher carbon contents may be approved subject to satisfactory results from welding procedure tests.

5.3.2 Welding is to be carried out in accordance with the requirements of *Ch 13 Requirements for Welded Construction* of the Rules for Materials, using welding procedures and welders that have been qualified in accordance with *Ch 12 Welding Qualifications* of the Rules for Materials.

5.3.3 Before welding is commenced the component parts of bedplates and framework are to be accurately fitted and aligned.

5.3.4 The welding is to be carried out in positions free from draughts and is to be downhand (flat) wherever practicable. Welding consumables are to be suitable for the materials being joined. Preheating is to be adopted when heavy plates or sections are welded. The finished welds are to have an even surface and are to be free from undercutting.

5.3.5 Welds attaching bearing housings to the transverse girders are to have a smooth contour and, if necessary, are to be made smooth by grinding.

5.4 Post-weld heat treatment

5.4.1 Bedplates are to be given a stress relieving heat treatment except engine types where the bedplate as a whole is not subjected to direct loading from the cylinder pressure. For these types, only the transverse girder assemblies need be stress relieved.

5.4.2 Stress relieving is to be carried out by heating the welded structure uniformly and slowly to a temperature between 580°C and 620°C, holding that temperature for not less than one hour per 25 mm of maximum plate thickness and thereafter allowing the structure to cool slowly in the furnace.

5.4.3 Omission of post-weld heat treatment of bedplates and their sub-assemblies will be considered on application by the engine builder with supporting evidence in accordance with *Ch 13, 2.10 Post-weld heat treatment 2.10.4* of the Rules for Materials.

5.5 Inspection

5.5.1 Welded engine structures are to be examined during fabrication, special attention being given to the fit of component parts of major joints prior to welding.

5.5.2 Inspection of welds is to be in accordance with the requirements of *Ch 13, 1.11 Non-destructive examination of welds* of the Rules for Materials.

5.5.3 Welds in transverse girder assemblies are to be crack detected by an approved method to the satisfaction of the Surveyors. Other joints are to be similarly tested if required by the Surveyors.

■ Section 6 Turning gear

6.1 General requirements

6.1.1 Turning gear is to be provided for all engines to facilitate operating and maintenance regimes as required by the manufacturer.

6.1.2 The turning gear for all main propulsion engines is to be power-driven and, if electric, is to be continuously rated at a value to ensure protection to the weakest part of the machinery.

6.1.3 The turning gear for auxiliary engines may be hand operated (manual) except where this is not practicable, in which case the provision of *Pt 5, Ch 2, 6.1 General requirements 6.1.2* is to be complied with.

6.1.4 The turning gear for all engines is to be fitted with safety interlocks which prevent engine operation when engaged, see *Pt 5, Ch 1, 3.10 Machinery interlocks*. Indication of engaged/not engaged is to be provided at all start positions.

6.1.5 The remote control device of power-driven turning gear is to be so designed that power is removed from the turning gear when the operating switch is released.

6.1.6 Means are to be provided to secure the turning gear when disengaged.

6.1.7 Overload protection arrangements are to be provided to prevent damage to the electric motor and the turning gear train.

■ Section 7 Control and monitoring of main, auxiliary and emergency engines

7.1 General

7.1.1 Control engineering systems are to be in accordance with the requirements of *Pt 6, Ch 1 Control Engineering Systems*.

7.1.2 Oil mist detection, or engine bearing temperature monitors or alternative methods for crankcase protection are to be provided:

(a) When arrangements are fitted to override the automatic shutdown for excessive reduction of the lubricating oil supply pressure.

(b) For engines of 2250 kW and above or having cylinders of more than 300 mm bore.

Note 1. For trunk piston engines, automatic shutdown of the engine is to occur.

Note 2. For crosshead engines, automatic slow-down is to occur.

Note 3. Where arrangements are made to override the automatic slow-down or shutdown due to high oil mist or bearing temperature, the override is to be independent of other overrides.

Note 4. Where the bearing temperature monitoring method is chosen, all bearings in the crankcase are to be monitored where practicable, e.g. main, crankpin, crosshead.

Note 5. Where engine bearing temperature monitors or alternative methods are provided for the prevention of the build-up of oil mist that may lead to a potentially explosive condition within the crankcase, details are to be submitted for consideration. The submission is to demonstrate that the arrangements are equivalent to those provided by oil mist detection, see *Pt 5, Ch 2, 10.8 Oil mist detection 10.8.14*.

7.1.3 All main and auxiliary engines intended for essential services are to be provided with means of indicating the lubricating oil pressure supply to them. Where such engines are of more than 37 kW (50 shp), audible and visual alarms are to be fitted to give warning of an appreciable reduction in pressure of the lubricating oil supply. Further, these alarms are to be actuated from the outlet side of any restrictions, such as filters, coolers, etc.

7.2 Main engine governors

7.2.1 An efficient governor is to be fitted to each main engine so adjusted that the speed does not exceed that for which the engine is to be classed by more than 15 per cent.

7.2.2 Engines coupled to electrical generators which are the source of power for main electric propulsion motors are to comply with the requirements for auxiliary engines in respect of governors and overspeed protection devices.

7.3 Auxiliary engine governors

7.3.1 Auxiliary engines intended for driving electric generators are to be fitted with governors which, with fixed setting, are to control the speed within 10 per cent momentary variation and 5 per cent permanent variation when the full load is suddenly taken off or, when after having run on no-load for at least 15 minutes, the load is suddenly applied as follows:

- (a) For engines with BMEP less than 8 bar, full load, or
- (b) For engines with BMEP greater than 8 bar, $\frac{800}{\text{BMEP}}$ per cent, but not less than one third, of full load, the full load being attained in not more than two additional equal stages as rapidly as possible.

7.3.2 If an engine cannot achieve the requirements of *Pt 5, Ch 2, 7.3 Auxiliary engine governors 7.3.1* then the actual load step is to be declared and verified through testing to ensure the requirements specified in *Pt 6, Ch 2, 1.7 Design and construction* are satisfied.

7.3.3 Emergency engines are to comply with *Pt 5, Ch 2, 7.3 Auxiliary engine governors 7.3.1* except that the initial load required by *Pt 5, Ch 2, 7.3 Auxiliary engine governors 7.3.1* is to be not less than the total connected emergency statutory load, or if their total consumer load is applied in steps, the following requirements are to be met:

- (a) the total load is supplied within 45 seconds from power failure on the main switchboard;
- (b) the maximum step load is declared and demonstrated; and
- (c) the power distribution system is designed such that the declared maximum step loading is not exceeded.

7.3.4 Compliance of time delays and loading sequence with the requirements of *Pt 5, Ch 2, 7.3 Auxiliary engine governors 7.3.2* is to be demonstrated at the ship's trials.

7.3.5 For alternating current installations, the permanent speed variation of the machines intended for parallel operation are to be equal within a tolerance of $\pm 0,5$ per cent. Momentary speed variations with load changes in accordance with *Pt 5, Ch 2, 7.3 Auxiliary engine governors 7.3.1* are to return to and remain within one per cent of the final steady state speed. This should normally be accomplished within five but in no case more than eight seconds. For quality of power supplies, see *Pt 6, Ch 2, 1.7 Design and construction*.

7.4 Overspeed protective devices

7.4.1 Each main engine developing 220kW (300 shp) or over which can be declutched or which drives a controllable pitch propeller, and also each auxiliary engine developing 220 kW (300 shp) and over for driving an electric generator, is to be fitted with an approved overspeed protective device.

7.4.2 The overspeed protective device, including its driving mechanism, is to be independent of the governor required by *Pt 5, Ch 2, 7.2 Main engine governors* or *Pt 5, Ch 2, 7.3 Auxiliary engine governors* and is to be so adjusted that the speed does not exceed that for which the engine and its driven machinery are to be classed by more than 20 per cent for main engines and 15 per cent for auxiliary engines.

7.5 Unattended machinery

7.5.1 Where main and auxiliary diesel engines are fitted with automatic or remote controls so that under normal operating conditions they do not require any manual intervention by the operators, they are to be provided with the alarms and safety arrangements required by *Pt 5, Ch 2, 7.5 Unattended machinery* to *Pt 5, Ch 2, 7.7 Auxiliary engines*, as appropriate. Alternative arrangements which provide equivalent safeguards will be considered.

7.5.2 Where machinery is arranged to start automatically or from a remote control station, interlocks are to be provided to prevent start-up under conditions which could hazard the machinery.

7.5.3 Where machinery specified in this Section is required to be provided with a standby pump, the standby pump is to start automatically if the discharge pressure from the working pumps falls below a predetermined value.

7.5.4 Where a first stage alarm together with a second stage alarm and automatic shutdown of machinery are required in the relevant Tables of this Section, the sensors and circuits utilised for the second stage alarm and automatic shutdown are to be independent of those required for the first stage alarm.

7.5.5 Means are to be provided to prevent leaks from high pressure fuel oil injection piping for main and auxiliary engines dripping or spraying onto hot surfaces or into machinery air inlets. Such leakage is to be collected and, where practicable, led to a collector tank(s) fitted in a safe position. An alarm is to be provided to indicate that leakage is taking place. These requirements may also be applicable to high pressure hydraulic oil piping, depending upon the location.

7.6 Engines for propulsion purposes

7.6.1 Alarms and safeguards are indicated in *Pt 5, Ch 2, 7.6 Engines for propulsion purposes 7.6.2* to *Pt 5, Ch 2, 7.6 Engines for propulsion purposes 7.6.8* and *Table 2.7.1 Engines for propulsion purposes: Alarms and slow-downs* and *Table 2.7.2 Engines for propulsion purposes: Automatic shutdowns*.

Table 2.7.1 Engines for propulsion purposes: Alarms and slow-downs

Item	Alarm	Note
Lubricating oil sump level	Low	Engines
Lubricating oil inlet pressure*	1st stage low	Engines. Slow-down
Lubricating oil inlet temperature*	High	Engines
Lubricating oil filters differential pressure	High	—
Oil mist concentration in crankcase or bearing temperature	High	See <i>Pt 5, Ch 2, 7.1 General 7.1.2</i> . Automatic slow-down of crosshead engines, for trunk piston engines see <i>Table 2.7.2 Engines for propulsion purposes: Automatic shutdowns</i>
Cylinder lubricator flow	Low	One sensor per lubricator unit on crosshead engines. Slow down.
Thrust bearing temperature*	High	Slow-down
Common rail servo oil pressure	Low	—
Piston coolant inlet pressure	Low	If a separate system. Slow-down
Piston coolant outlet temperature*	High	Per cylinder (if a separate system). Slow-down
Piston coolant outlet flow*	Low	Per cylinder (if a separate system)
Cylinder coolant inlet pressure or flow*	Low	Slow-down (automatic on trunk piston engines)
Cylinder coolant outlet temperature*	1st stage high	Per cylinder (if a separate system). Slow-down (automatic on trunk piston engines)
Engine cooling water system – oil content	High	Where engine cooling water used in oil/water heat exchangers
Sea-water cooling pressure	Low	—
Fuel valve coolant pressure	Low	If a separate system

Fuel valve coolant temperature	High	If a separate system
Fuel oil pressure from booster pump	Low	—
Fuel oil temperature or viscosity*	High and Low	Heavy oil only
Fuel oil high pressure piping*	Leakage	See Pt 5, Ch 2, 7.5 Unattended machinery 7.5.5
Common rail fuel oil pressure	Low	—
Charge air cooler outlet temperature	High	Trunk piston engines
Scavenge air temperature (fire)	High	Per cylinder (2-stroke engines). Slow-down
Scavenge air receiver water level	High	—
Exhaust gas temperature*	High	Per cylinder. Slow-down (automatic on trunk piston engines), see Note 5
Exhaust gas temperature deviation from average*	High	Per cylinder, see Note 5
Turbocharger exhaust gas inlet temperature	High	Each turbocharger see Note 6
Turbocharger exhaust gas outlet temperature*	High	Each turbocharger
Turbocharger lubricating oil inlet pressure	Low	See Note 10
Turbocharger lubricating oil outlet temperature	High	Each bearing, if system not integral with turbocharger. See Note 7 and 10
Starting air pressure*	Low	Before engine manoeuvring valve
Control air pressure	Low	—
Direction of rotation	Wrong way	Reversible engines, see also Pt 5, Ch 2, 7.6 Engines for propulsion purposes 7.6.7
Automatic start of engine	Failure	See Pt 5, Ch 2, 7.6 Engines for propulsion purposes 7.6.7
Electrical starting battery charge level	Low	—
Feed water or water/thermal fluid forced circulation flow (if fitted)	Low	See Pt 5, Ch 14, 6.2 Feed and circulation pumps 6.2.7 and Note 8

Uptake temperature	High	To monitor for soot fires. See Notes 8 and 9
<p>Note 1. Where 'per cylinder' appears in this Table, suitable sensors may be situated on manifold outlets for trunk piston engines.</p> <p>Note 2. For engines and gearing of 1500 kW or less, only the items marked* are required.</p> <p>Note 3. Common sensors are acceptable for alarms and slow-down functions.</p> <p>Note 4. Except where stated otherwise in the Table, slow-down may be effected by either manual or automatic means, by reduction of speed or power as appropriate.</p> <p>Note 5. For trunk piston engine power <500 kW/cylinder, a common sensor for exhaust gas manifold temperature may be fitted.</p> <p>Note 6. Alarm and indication of the exhaust gas temperature at turbocharger inlet may be waived if alarm and indication for individual exhaust gas temperature is provided for each cylinder and the alarm level is set to a value specified by the turbocharger manufacturer.</p> <p>Note 7. Where the outlet temperature for each bearing cannot be measured due to the design, details of alternative proposals in accordance with the turbocharger manufacturer's instructions may be submitted for consideration.</p> <p>Note 8. Alarm only required when an exhaust gas economiser/boiler/thermal oil heater is fitted.</p> <p>Note 9. Alternatively, details of an appropriate fire detection system are to be submitted for consideration.</p> <p>Note 10. Separate sensors are to be provided if the lubrication oil system of the turbocharger is not integrated with the lubrication oil system of the engine or if it is separated by a throttle or pressure reduction valve from the engine lubrication oil system. Where the turbocharger is provided with a self-contained lubricating oil system integrated with the turbocharger, lubricating oil inlet pressure need not be monitored.</p>		

Table 2.7.2 Engines for propulsion purposes: Automatic shutdowns

Item	Alarm	Note
Lubricating oil inlet pressure	2nd stage low	Automatic shutdown of engines, see Pt 5, Ch 2, 7.5 Unattended machinery 7.5.4
Oil mist concentration in crankcase or bearing temperature	High	See Pt 5, Ch 2, 7.1 General 7.1.2 Automatic shutdown of trunk piston engines, for crosshead engines see Table 2.7.1 Engines for propulsion purposes: Alarms and slow-downs
Cylinder coolant outlet temperature	2nd stage high	Automatic shutdown of trunk piston engines, see Pt 5, Ch 2, 7.5 Unattended machinery 7.5.4
Overspeed	High	Automatic shutdown of engine, see also Pt 5, Ch 2, 7.4 Overspeed protective devices. Details of alternative proposals in accordance with the manufacturer's instructions may be submitted for consideration

7.6.2 Alarms are to operate for the fault conditions shown in Table 2.7.1 Engines for propulsion purposes: Alarms and slow-downs. Where applicable, indication is to be given at the relevant control stations that the speed or power of the main propulsion engine(s) is to be manually reduced or has been reduced automatically.

7.6.3 Alarms are to operate, and automatic shutdown of machinery is to occur for the fault conditions shown in Table 2.7.2 Engines for propulsion purposes: Automatic shutdowns.

7.6.4 The following engine services are to be fitted with automatic temperature controls so as to maintain steady state conditions throughout the normal operating range of the propulsion engine(s).

- (a) Lubricating oil supply.
- (b) Fuel oil supply, see also Pt 5, Ch 2, 7.6 Engines for propulsion purposes 7.6.5.
- (c) Piston coolant supply, where applicable.
- (d) Cylinder coolant supply, where applicable.
- (e) Fuel valve coolant supply, where applicable.

7.6.5 The fuel oil supply may be fitted with an automatic control for viscosity instead of the temperature control required by Pt 5, Ch 2, 7.6 Engines for propulsion purposes 7.6.4.

7.6.6 Indication of the starting air pressure is to be provided at each control station from which it is possible to start the main propulsion engine(s).

7.6.7 The number of automatic consecutive attempts which fail to produce a start is to be limited to three. For reversible engines which are started and stopped for manoeuvring purposes, means are to be provided to maintain sufficient starting air in the air receivers. For electric starting, see *Pt 5, Ch 2, 13.4 Design and Construction*.

7.6.8 Prolonged running in a restricted speed range is to be prevented automatically or, alternatively, an indication of restricted speed ranges is to be provided at each control station.

7.7 Auxiliary engines

7.7.1 Alarms and safeguards are indicated in *Table 2.7.3 Auxiliary engines: Alarms and safeguards*.

Table 2.7.3 Auxiliary engines: Alarms and safeguards

Item	Alarm	Note
Lubricating oil inlet temperature	High	—
Lubricating oil inlet pressure	1st stage low	—
	2nd stage low	Automatic shutdown of engine, see <i>Pt 5, Ch 2, 7.5 Unattended machinery 7.5.4</i>
Oil mist concentration in crankcase or bearing temperature	High	Automatic shutdown of engine, see <i>Pt 5, Ch 2, 7.1 General 7.1.2</i>
Fuel oil high pressure piping	Leakage	See <i>Pt 5, Ch 2, 7.5 Unattended machinery 7.5.5</i>
Coolant outlet temperature (for engines >220 kW)	1st stage high	—
	2nd stage high	Automatic shutdown of engine, see <i>Pt 5, Ch 2, 7.5 Unattended machinery 7.5.4</i>
Coolant pressure or flow	Low	—
Fuel oil temperature or viscosity	High and Low	Heavy oil only
Overspeed	High	Automatic shutdown of engine, see also <i>Pt 5, Ch 2, 7.4 Overspeed protective devices</i> .
		Details of alternative proposals in accordance with the manufacturer's instructions may be submitted for consideration
Common rail servo oil pressure	Low	—
Common rail fuel oil pressure	Low	—
Starting air pressure	Low	—
Electrical starting battery charge level	Low	—
Exhaust gas temperature (for engines >500 kW/cylinder)	High	Per cylinder.
Feed water or water/thermal fluid forced circulation flow (if fitted)	Low	See <i>Pt 5, Ch 14, 6.2 Feed and circulation pumps 6.2.7</i> and Note 3
Uptake temperature	High	To monitor for soot fires. See Notes 3 and 4
Turbocharger lubricating oil outlet temperature	High	Each bearing, see Note 5

Turbocharger lubrication oil inlet pressure	Low	See Note 6
---	-----	------------

Note 1. For emergency diesel engines, including engines used for the emergency source of electrical power required by SOLAS - *International Convention for the Safety of Life at Sea*, see Pt 5, Ch 2, 13 Air compressors.

Note 2. The arrangements are to comply with the requirements of the National Authority concerned.

Note 3. Alarm only required when an exhaust gas economiser/boiler/thermal oil heater is fitted.

Note 4. Alternatively, details of an appropriate fire detection system are to be submitted for consideration.

Note 5. Unless provided with a self-contained lubricating oil system integrated with the turbocharger.

Note 6. Where outlet temperature from each bearing cannot be monitored due to the engine/turbocharger design alternative arrangements may be accepted. Continuous monitoring of inlet pressure and inlet temperature in combination with specific intervals for bearing inspection in accordance with the turbocharger manufacturer’s instructions may be accepted as an alternative.

7.7.2 For engines operating on heavy fuel oil, automatic temperature or viscosity controls are to be provided.

7.8 Emergency engines

7.8.1 Alarms and safeguards are to be fitted in accordance with *Table 2.7.4 Emergency engines: Alarms and safeguards*.

Table 2.7.4 Emergency engines: Alarms and safeguards

Item	Alarm for engine power <220 kW	Alarm for engine power ≥ 220kW	Note
Fuel oil leakage from pressure pipes	Leakage	Leakage	See Pt 5, Ch 2, 7.1 General 7.1.2
Lubricating oil temperature	—	High	—
Lubricating oil pressure	Low	Low	—
Oil mist concentration in crankcase	—	High	See Note
Coolant pressure or flow	—	Low	—
Coolant temperature (can be air)	High	High	—
Overspeed	—	High	Automatic shutdown

Note For engines having a power of more than 2250 kW or a cylinder bore of more than 300 mm.

7.8.2 The safety and alarm systems are to be designed to ‘fail safe’. The characteristics of the ‘fail safe’ operation are to be evaluated on the basis not only of the system and its associated machinery, but also the complete installation, as well as the ship.

7.8.3 Regardless of the engine output power, if shutdowns additional to those specified in *Table 2.7.4 Emergency engines: Alarms and safeguards* are provided except for the overspeed shutdown, they are to be automatically overridden when the engine is in automatic or remote control mode during navigation.

7.8.4 Grouped alarms of at least those items listed in *Table 2.7.4 Emergency engines: Alarms and safeguards* are to be arranged on the bridge.

7.8.5 In addition to the fuel oil control from outside the space, a local means of engine shutdown is to be provided.

7.8.6 Local indications of at least those items listed in *Table 2.7.4 Emergency engines: Alarms and safeguards* are to be provided within the same space as the diesel engines and are to remain operational in the event of failure of the alarm and safety systems.

■ Section 8 Piping

8.1 Fuel oil, hydraulic and high pressure oil systems

- 8.1.1 Fuel oil and hydraulic oil piping systems arrangements are to comply with *Pt 5, Ch 12 Piping Design Requirements* and *Pt 5, Ch 14 Machinery Piping Systems* as applicable.
- 8.1.2 Fuel oil pipe systems in general, tanks and their fittings are to comply with the requirements of *Pt 5, Ch 14 Machinery Piping Systems* and *Pt 3 Ship Structures (General)*.
- 8.1.3 Where pumps are essential for engine operation, not less than two fuel oil and two hydraulic oil pressure pumps are to be provided for their respective service and arranged such that failure of one pump does not render the other inoperative. Each fuel oil pump and hydraulic oil pump is to be capable of supplying the quantity of oil for engine operation at its maximum continuous rating and arranged ready for immediate use.
- 8.1.4 All external high pressure fuel system piping between the high pressure fuel pumps and fuel injectors are to be protected with a jacketed piping system capable of containing leakage and/or spray of flammable fluid from a high-pressure pipe failure. The arrangements are to be approved, see *Table 2.1.1 Plans and particulars to be submitted for appraisal*.
- 8.1.5 The hydraulic oil pressure piping between the high-pressure hydraulic pumps and hydraulic actuators is to be protected with a jacketed piping system capable of containing hydraulic oil leakage from a high-pressure pipe failure.
- 8.1.6 Where flammable oils are used in high-pressure systems, the oil pipe lines between the high-pressure oil pump and actuating oil pistons are to be protected with a jacketed piping system capable of preventing oil spray from a high-pressure line failure.
- 8.1.7 Accumulators and associated high-pressure piping are to be designed, manufactured and tested in accordance with a standard applicable to the maximum pressure and temperature rating of the system.
- 8.1.8 Diesel engine fuel system components are to be designed to accommodate the maximum peak pressures experienced in service. In particular this applies to the fuel injection pump supply and spill line piping which may be subject to high-pressure pulses from the pump. Connections on such piping systems should be chosen to minimise the risk of pressurised fuel oil leaks.
- 8.1.9 The protection is to prevent fuel oil or fuel oil mist from reaching a source of ignition on the engine or its surroundings. Suitable drainage arrangements are to be made for draining any fuel oil leakage to collector tank(s) fitted in a safe position. An alarm is to be provided to indicate that leakage is taking place.
- 8.1.10 Where multi-engined installations are supplied from the same fuel source, means of isolating the fuel supply and spill piping to individual engines are to be provided. These means of isolation are not to affect the operation of the other engines and are to be operable from a position not rendered inaccessible by a fire on any of the engines.
- 8.1.11 All valves, cocks and screwed connections are to be of a type-tested type applicable to the maximum service conditions anticipated in normal service.
- 8.1.12 Isolating valves and cocks are to be located as near as practicable to the equipment to be isolated. All valves forming part of the fuel oil and hydraulic oil installation are to be capable of being controlled from readily accessible positions above the working platform.
- 8.1.13 High pressure fuel oil and high-pressure hydraulic oil piping systems are to be provided with high-pressure alarms with set points that do not exceed the system design pressures.
- 8.1.14 High pressure fuel oil and high-pressure hydraulic piping systems are to be provided with suitable relief valves on any part of the system that can be isolated and in which pressure can be generated. The settings of the relief valves are not to exceed the design pressures. The valves are to be of adequate size and so arranged as to avoid an undue rise in pressure above the design pressures.
- 8.1.15 Equipment fitted for monitoring pressures and temperatures in the high-pressure fuel oil and high-pressure hydraulic oil systems is to comply with a Recognised Standard suitable to the anticipated vibration and temperature conditions.
- 8.1.16 A fatigue analysis is to be carried out in accordance with a standard applicable to the system under consideration and all anticipated pressure, pulsation and vibration loads are to be addressed. The analysis is to demonstrate that the design and arrangements are such that the likelihood of failure is as low as reasonably practicable. The analysis is to identify all assumptions

made and standards to be applied during manufacture and testing of the system. Any potential weak points which may develop due to incorrect construction or assembly are also to be identified.

8.1.17 For high-pressure oil containing and mechanical power transmission systems, the quality plan for sourcing, design, installation and testing of components is to address the following issues:

- (a) Design and manufacturing standard(s) applied.
- (b) Materials used for construction of key components and their sources.
- (c) Details of the quality control system applied during manufacture and testing.
- (d) Details of type approval, type testing or approved type status assigned to the machinery or equipment.
- (e) Details of installation and testing recommendations for the machinery or equipment.

8.2 Exhaust systems

8.2.1 Where the surface temperature of the exhaust pipes and silencer may exceed 220°C, they are to be water cooled or efficiently lagged to minimise the risk of fire and to prevent damage by heat. Where lagging covering the exhaust piping system including flanges is oil-absorbing or may permit penetration of oil, the lagging is to be encased in sheet metal or equivalent. In locations where the Surveyor is satisfied that oil impingement could not occur, the lagging need not be encased.

8.2.2 Where the exhaust is led overboard near the waterline, means are to be provided to prevent water from being siphoned back to the engine. Where the exhaust is cooled by water spray, the exhaust pipes are to be self-draining overboard.

8.2.3 Where the exhausts of two or more engines are led to a common silencer or exhaust gas-heated boiler or economiser, an isolating device is to be provided in each exhaust pipe.

8.2.4 For alternatively fired furnaces of boilers using exhaust gases and fuel oil, the exhaust gas inlet pipe is to be provided with an isolating device and interlocking arrangements whereby fuel oil can only be supplied to the burners when the isolating device is closed to the boiler.

8.2.5 In two-stroke main engines fitted with exhaust gas turbo-blowers which operate on the impulse system, provision is to be made to prevent broken piston rings entering the turbine casing and causing damage to blades and nozzle rings.

8.3 Starting air pipe systems and safety fittings

8.3.1 In designing the compressed air installation, care is to be taken that the compressor air inlets will be located in an atmosphere reasonably free from oil vapour or, alternatively, an air duct from outside the machinery space is to be led to the compressors.

8.3.2 The air discharge pipe from the compressors is to be led direct to the starting air receivers. Provision is to be made for intercepting and draining oil and water in the air discharge for which purpose a separator or filter is to be fitted in the discharge pipe between compressors and receivers.

8.3.3 The starting air pipe system from receivers to main and auxiliary engines is to be entirely separate from the compressor discharge pipe system. Stop valves on the receivers are to permit slow opening to avoid sudden pressure rises in the piping system. Valve chests and fittings in the piping system are to be of ductile material.

8.3.4 Drain valves for removing accumulations of oil and water are to be fitted on compressors, separators, filters and receivers. In the case of any low-level pipelines, drain valves are to be fitted to suitably located drain pots or separators.

8.3.5 The starting air piping system is to be protected against the effects of explosions by providing an isolating non-return valve or equivalent at the starting air supply to each engine.

8.3.6 In direct reversing engines bursting discs or flame arresters are to be fitted at the starting valves on each cylinder; in non-reversing and auxiliary engines at least one such device is to be fitted at the supply inlet to the starting air manifold on each engine. The fitting of bursting discs or flame arresters may be waived in engines where the cylinder bore does not exceed 230 mm.

8.3.7 Alternative safety arrangements may be submitted for consideration.

■ Section 9

Starting arrangements

9.1 Dead ship condition starting arrangements

9.1.1 Means are to be provided to ensure that machinery can be brought into operation from the dead ship condition without external aid.

9.1.2 Dead ship condition for the purpose of *Pt 5, Ch 2, 9.1 Dead ship condition starting arrangements 9.1.1* is to be understood to mean a condition under which the main propulsion plant, boilers and auxiliaries are not in operation. In restoring propulsion, no stored energy for starting and operating the propulsion plant is assumed to be available. Additionally, neither the main source of electrical power nor other essential auxiliaries is assumed to be available for starting and operating the propulsion plant.

9.1.3 Where the emergency source of power is an emergency generator which fully complies with the requirements of *Pt 6, Ch 2 Electrical Engineering*, this generator may be used for restoring operation of the main propulsion plant, boilers and auxiliaries where any power supplies necessary for engine operation are also protected to a similar level as the starting arrangements.

9.1.4 Where there is no emergency generator installed or an emergency generator does not comply with *Pt 6, Ch 2 Electrical Engineering*, the arrangements for bringing main and auxiliary machinery into operation are to be such that the initial charge of starting air or initial electrical power and any power supplies for engine operation can be developed on board ship without external aid. If for this purpose an emergency air compressor or an electric generator is required, these units are to be powered by a hand-starting oil engine or a hand-operated compressor. The arrangements for bringing main and auxiliary machinery into operation are to have capacity such that the starting energy and any power supplies for engine operation are available within 30 minutes of a dead ship condition.

9.1.5 For cargo ships of less than 500 gross tons and which are not required to comply with the *International Convention for the Safety of Life at Sea, 1974*, as amended (SOLAS 74), alternative arrangements to those specified in *Pt 5, Ch 2, 9.1 Dead ship condition starting arrangements 9.1.3* or *Pt 5, Ch 2, 9.1 Dead ship condition starting arrangements 9.1.4* may be proposed for consideration. Details of the alternative arrangements are to be included in the plans and details required by *Table 2.1.1 Plans and particulars to be submitted for appraisal* and are to demonstrate that the arrangements provide for starting from the dead ship condition and are in accordance with any applicable statutory requirements of the National Authority of the country in which the ship is to be registered.

9.2 Air receiver capacity

9.2.1 Where the main engine is arranged for air starting the total air receiver capacity is to be sufficient to provide without replenishment, not less than 12 consecutive starts of the main engine, alternating between ahead and astern if of the reversible type and not less than 6 consecutive starts if of the non-reversible type. At least two air receivers of approximately equal capacity are to be provided. For scantlings and fittings of air receivers, see *Pt 5, Ch 12 Piping Design Requirements*.

9.2.2 For multi-engine installations, the number of starts required for each engine are to be as follows:

- (a) Two engines through common reduction gearing: 6 starts per engine for fixed pitch propeller/propellers; 3 starts per engine for controllable pitch propeller/ propellers.
- (b) Three engines or more through common reduction gearing: 3 starts per engine.

9.2.3 No engine is to have fewer than 3 starts for any arrangement. For electric propulsion arrangements, a minimum of 3 starts per engine with a minimum capacity of 12 starts of the largest start air consumption engine in total are required.

9.3 Electric starting

9.3.1 Where main engines are fitted with electric starters, two batteries are to be fitted. Each battery is to be capable of starting the engines when cold and the combined capacity is to be sufficient without recharging to provide the number of starts of the main engines as required by *Pt 5, Ch 2, 9.2 Air receiver capacity*. In other respects batteries are to comply with the requirements of *Pt 6, Ch 2, 11 Electric cables, optical fibre cables and busbar trunking systems (busways)*.

9.3.2 Electric starting arrangements for auxiliary engines are to have two separate batteries or be supplied by separate circuits from the main engine batteries when such are provided. Where one of the auxiliary engines only is fitted with an electric starter one battery will be acceptable.

9.3.3 The combined capacity of the batteries for starting the auxiliary engines is to be sufficient for at least three starts for each engine.

9.3.4 Engine starting batteries are to be used only for the purposes of starting the engines and for the engines' own control, alarm, monitoring and safety arrangements. Means are to be provided to ensure that the stored energy in the batteries is maintained at a level required to start the engines, as defined in *Pt 5, Ch 2, 9.3 Electric starting 9.3.1* and *Pt 5, Ch 2, 9.3 Electric starting 9.3.3*.

9.3.5 Where engines are fitted with electric starting batteries, an alarm is to be provided for low battery charge level.

9.3.6 For cargo ships of less than 500 gross tons which are not required to comply with the *International Convention for the Safety of Life at Sea, 1974*, as amended (SOLAS 74), the emergency source of electrical power may be used as one of the sources of energy required by *Pt 5, Ch 2, 9.3 Electric starting 9.3.1* or *Pt 5, Ch 2, 9.3 Electric starting 9.3.2* for electric starting. Where the emergency source of electrical power is an accumulator battery and it is to be used for electric starting, it is to have the additional capacity required to ensure emergency supplies are not compromised and is to be adequately protected and suitably located for use in an emergency.

9.4 Starting of the emergency source of power

9.4.1 Emergency generators are to be capable of being readily started in their cold conditions down to a temperature of 0°C. If this is impracticable, or if lower temperatures are likely to be encountered, consideration is to be given to the provision and maintenance of heating arrangements, so that ready starting will be assured.

9.4.2 Each emergency generator that is arranged to be automatically started is to be equipped with an approved starting system having two independent sources of stored energy, each of which is sufficient for at least three consecutive starts. When hand (manual) starting is demonstrated to be effective, only one source of stored energy need be provided. However, this source of stored energy is to be protected against depletion below the level required for starting.

9.4.3 Provision is to be made to maintain continuously the stored energy at all times, and for this purpose:

- (a) Electrical and hydraulic starting systems are to be maintained from the emergency switchboard.
- (b) Compressed air starting systems may be maintained by the main or auxiliary compressed air receivers, through a suitable non-return valve, or by an emergency air compressor energised by the emergency switchboard.
- (c) All these starting, charging and energy storing devices are to be located in the emergency generator room. These devices are not to be used for any purpose other than the operation of the emergency generator.

9.4.4 When automatic starting is not required by the Rules and where it can be demonstrated as being effective, hand (manual) starting is permissible, such as manual cranking, inertial starters, manual hydraulic accumulators, powder charge cartridges.

9.4.5 When hand (manual) starting is not practicable, the provisions under *Pt 5, Ch 2, 9.4 Starting of the emergency source of power 9.4.2* and *Pt 5, Ch 2, 9.4 Starting of the emergency source of power 9.4.3* are to be complied with except that starting may be manually initiated.

9.4.6 Electric starting arrangements are also to satisfy *Pt 5, Ch 2, 9.3 Electric starting 9.3.2* to *Pt 5, Ch 2, 9.3 Electric starting 9.3.5*.

9.5 Engine control, alarm monitoring and safety system power supplies

9.5.1 Power supplies are to be arranged so that power for electrically powered control, alarm, monitoring and safety systems required for engine starting and operation will remain available in the event of a failure. Power is to remain available to permit starting attempts for the number of starts specified by this Section for each individual source of stored energy.

9.5.2 Where adequate battery and charging capacity exists, an engine starting battery may be used as one source of electrical power required by *Pt 5, Ch 2, 9.5 Engine control, alarm monitoring and safety system power supplies 9.5.1*.

9.5.3 An alarm is to be activated in the event of failure of a power supply and, where applicable, low battery charge level. Manual power supply changeover facilities are permitted.

■ Section 10 Safety arrangements

10.1 Relief valves

10.1.1 Scavenge spaces in open connection with cylinders are to be provided with explosion relief valves.

10.1.2 Crankcases are to be provided with lightweight spring-loaded valves or other quick-acting and self-closing devices to relieve the crankcases of pressure in the event of an internal explosion and to prevent any inrush of air thereafter. The valves are to be designed and constructed to open quickly and be fully open at a pressure not greater than 0,2 bar.

10.1.3 The valve lids are to be made of ductile material capable of withstanding the shock of contact with stoppers at the full open position.

10.1.4 Each valve is to be fitted with a flame arrester that permits flow for crankcase pressure relief and prevents the passage of flame following a crankcase explosion. The valves are to be type tested in a configuration that represents the installation arrangements that will be used on an engine and in accordance with *Pt 5, Ch 2, 14.3 Crankcase explosion relief valves*. The valves are to be positioned on engines to minimise the possibility of danger and damage arising from emission of the crankcase atmosphere. Where shielding from the emissions is fitted to a valve, the valve is to be type tested to demonstrate that the shielding does not adversely affect the operational effectiveness of the valve.

10.1.5 The valves are to be provided with a copy of the manufacturer's installation and maintenance manual for the size and type of valve being supplied for installation on a particular engine. The manual is to contain the following information:

- Description of valve with details of function and design limits.
- Copy of type test certification.
- Installation instructions.
- Maintenance and in service instructions to include testing and renewal of any sealing arrangements.
- Actions required after a crankcase explosion.

10.1.6 A copy of the installation and maintenance manual required by *Pt 5, Ch 2, 10.1 Relief valves 10.1.5* is to be provided on board the ship.

10.1.7 Plans showing details and arrangements of the relief valves are to be submitted for approval, see *Pt 5, Ch 2, 1.2 Submission requirements*.

10.1.8 The valves are to be provided with suitable markings that include the following information:

- Name and address of manufacturer.
- Designation and size.
- Month/Year of manufacture.
- Approved installation orientation.

10.2 Number of relief valves

10.2.1 Internal combustion engines having a cylinder bore of 200 mm and above or a crankcase volume of 0,6 m³ and above shall be provided with crankcase explosion relief valves.

10.2.2 In engines having cylinders exceeding 200 mm but not exceeding 250 mm bore, at least two relief valves are to be fitted; each valve is to be located at or near the ends of the crankcase. Where the engine has more than eight crank throws an additional valve is to be fitted near the centre of the engine.

10.2.3 In engines having cylinders exceeding 250 mm but not exceeding 300 mm bore, at least one relief valve is to be fitted in way of each alternate crank throw with a minimum of two valves. For engines having 3, 5, 7, 9, etc. crank throws, the number of relief valves is not to be less than 2, 3, 4, 5, etc. respectively.

10.2.4 In engines having cylinders exceeding 300 mm bore at least one valve is to be fitted in way of each main crank throw.

10.2.5 Additional relief valves are to be fitted for separate spaces on the crankcase, such as gear or chaincases for camshaft or similar drives, when the gross volume of such spaces exceeds 0,6 m³.

10.3 Size of relief valves

10.3.1 The combined free area of the crankcase relief valves fitted on an engine is to be not less than $115 \text{ cm}^2/\text{m}^3$ based on the volume of the crankcase.

10.3.2 The free area of each relief valve is to be not less than 45 cm^2 .

10.3.3 The free area of the relief valve is the minimum flow area at any section through the valve when the valve is fully open.

10.3.4 In determining the volume of the crankcase for the purpose of calculating the combined free area of the crankcase relief valves, the volume of the stationary parts within the crankcase may be deducted from the total internal volume of the crankcase.

10.4 Vent pipes

10.4.1 Through ventilation, and any arrangement which could produce a flow of external air within the crankcase, is in principle not permitted except for trunk piston type dual fuel engines where crankcase ventilation is to be provided. Where crankcase vent or breather pipes are fitted, they are to be made as small as practicable and/or as long as possible to minimise the inrush of air after an explosion. Vents or breather pipes from crankcases of main engines are to be led to a safe position on deck or other approved position.

10.4.2 If provision is made for the extraction of gases from within the crankcase, e.g. for oil mist detection purposes, the vacuum within the crankcase is not to exceed 25 mm of water.

10.4.3 Lubricating oil drain pipes from engine sump to drain tank are to be submerged at their outlet ends. Where two or more engines are installed, vent pipes, if fitted, and lubrication oil drain pipes are to be independent to avoid intercommunication between crankcases.

10.5 Warning notice

10.5.1 A warning notice is to be fitted in a prominent position, preferably on a crankcase door on each side of the engine, or alternatively at the engine room control station. This warning notice is to specify that whenever overheating is suspected in the crankcase, the crankcase doors or sight holes are not to be opened until a reasonable time has elapsed after stopping the engine, sufficient to permit adequate cooling within the crankcase.

10.6 Crankcase access and lighting

10.6.1 Where access to crankcase spaces is necessary for inspection purposes, suitably positioned rungs or equivalent arrangements are to be provided as considered appropriate.

10.6.2 When interior lighting is provided it is to be flameproof in relation to the interior and details are to be submitted for approval. No wiring is to be fitted inside the crankcase.

10.7 Fire-extinguishing system for scavenge manifolds

10.7.1 Crosshead type engine scavenge spaces in open connection with cylinders are to be provided with approved fixed or portable fire-extinguishing arrangements which are to be independent of the fire-extinguishing system of the engine room.

10.8 Oil mist detection

10.8.1 Where crankcase oil mist detection arrangements are fitted, they are to be of a type approved by LR, tested in accordance with *Pt 5, Ch 2, 14.4 Crankcase oil mist detection system* and comply with *Pt 5, Ch 2, 10.8 Oil mist detection 10.8.2* to *Pt 5, Ch 2, 10.8 Oil mist detection 10.8.15*.

10.8.2 The oil mist detection system and arrangements are to be installed in accordance with the engine designer's and oil mist detection equipment manufacturer's instructions/recommendations. The following particulars are to be included in the instructions:

- (a) A schematic layout of the engine oil mist detection and alarm system showing locations of engine crankcase sample points and cabling/piping arrangements together with pipe dimensions to the detector.
- (b) Evidence of study to justify the selected locations of sample points and sample extraction rate (if applicable) in consideration of the crankcase arrangements and geometry and the predicted crankcase atmosphere where oil mist can accumulate.
- (c) The manufacturer's maintenance and test manual.
- (d) Information relating to type or in-service testing of the engine with engine protection system test arrangements having approved types of oil mist detection equipment.

10.8.3 A copy of the oil mist detection equipment maintenance and test manual required by *Pt 5, Ch 2, 10.8 Oil mist detection 10.8.2* is to be provided on board ship.

10.8.4 Oil mist detection and alarm information is to be capable of being read from a safe location away from the engine.

10.8.5 In the case of multi engine installations, each engine is to be provided with individual, dedicated oil mist detection arrangements and alarm(s).

10.8.6 Oil mist detection and alarm systems are to be capable of being tested on the test bed and on board when the engine is at a standstill and when the engine is running at normal operating conditions in accordance with test procedures that are acceptable to LR.

10.8.7 Alarms and safeguards for the oil mist detection system are to be in accordance with *Pt 6, Ch 1 Control Engineering Systems* as applicable.

10.8.8 The oil mist detection arrangements are to provide an alarm indication in the event of a foreseeable functional failure in the equipment and installation arrangements. See *Pt 6, Ch 1, 2.4 Safety systems, general requirements 2.4.5*.

10.8.9 The oil mist detection system is to provide an indication that any lenses fitted in the equipment and used in determination of the oil mist level have been partially obscured to a degree that will affect the reliability of the information and alarm indication.

10.8.10 Where oil mist detection equipment includes the use of programmable electronic systems, the arrangements are to be in accordance with *Pt 6, Ch 1 Control Engineering Systems* as applicable.

10.8.11 Schematic layouts showing details and arrangements of oil mist detection and alarm systems are to be submitted. See *Pt 5, Ch 1, 1 General*.

10.8.12 The equipment together with detectors is to be tested when installed on the test bed and on board ship to demonstrate that the detection and alarm system functions correctly. The testing arrangements are to be to the satisfaction of the Surveyor.

10.8.13 Where sequential oil mist detection arrangements are provided, the sampling frequency and time is to be as short as reasonably practicable.

10.8.14 Where alternative methods are provided for the prevention of the build-up of oil mist that may lead to a potentially explosive condition within the crankcase, detailed information is to be submitted for consideration. The information is to include:

- (a) Engine particulars – type, power, speed, stroke, bore and crankcase volume.
- (b) Details of arrangements designed to prevent the build up of potentially explosive conditions within the crankcase, e.g. bearing temperature monitoring, oil splash temperature monitoring, crankcase pressure monitoring, and recirculation arrangements.
- (c) Evidence to demonstrate that the arrangements are effective in preventing the build up of potentially explosive conditions together with details of in-service experience.
- (d) Operating instructions and the maintenance and test instructions.

10.8.15 Where it is proposed to use the introduction of inert gas into the crankcase to minimise a potential crankcase explosion, details of the arrangements are to be submitted for consideration.

■ Section 11

Factory Acceptance Test and Shipboard Trials of Internal Combustion Engines

11.1 Safety

11.1.1 Before any test is carried out, all relevant equipment for the safety of attending personnel is to be made available by the manufacturer/shipyard and is to be operational. This is to include crankcase explosive conditions protection, overspeed protection and any other shutdown function.

11.1.2 The overspeed protective device is to be set to a value which is not higher than the overspeed value that was demonstrated during the type test for that engine. This set point is to be verified by the Surveyor.

11.2 General

11.2.1 Engines which are to be subjected to trials on the test bed at the manufacturer's works and under attendance by the Surveyor(s) are to be tested in accordance with the scope of works trials specified in *Pt 5, Ch 2, 11.3 Works trials (factory acceptance test)*. The scope of the trials is to be agreed between the LR Surveyor and the manufacturer prior to testing. At the discretion of the Surveyor, the scope of the trials may be extended depending on the engine application.

11.2.2 Where multiple engines of the same design are manufactured, a quality assurance approach to approval may be applied if the manufacturer meets the requirements of and is registered on the Quality Assurance Scheme for Machinery (QAM). (See *Pt 5, Ch 1, 6 Quality Assurance Scheme for Machinery*).

11.2.3 Before any official testing the engines are to be run in as prescribed by the engine manufacturer.

11.2.4 Adequate test bed facilities for loads as required in *Table 2.11.1 Scope of works trials for engines* are to be provided. All fluids used for testing purposes such as fuel, lubrication oil and cooling water are to be suitable for the purpose intended, e.g. they are to be clean, and if necessary pre-heated to achieve the recommended operating temperature. This applies to all fluids used temporarily or repeatedly for testing purposes only.

11.2.5 Survey of the engine is to include:

- (a) Jacketing of high-pressure fuel oil lines including the system used for the detection of leakage.
- (b) Screening of pipe connections in piping containing flammable liquids.
- (c) Insulation of hot surfaces by taking random temperature readings that are to be compared with corresponding readings obtained during the type test. This is to be done while running at the maximum approved rating for the actual application. Use of contact thermometers may be accepted at the discretion of the attending Surveyor. If the insulation is modified subsequently to the Type Approval Test, LR may request more enhanced temperature measurements as required by the LR's Type Approval Test Specification No. 4, Section 10.2.7 (Fire Protection Measures).

These surveys are normally to be made during the works trials by the manufacturer and the attending Surveyor, but at the discretion of LR parts of these surveys may be postponed to the shipboard testing.

11.2.6 Where the type test was not carried out on the complete engine, as described in *Pt 5, Ch 2, 1.1 Approval process 1.1.2*, integration tests are to be conducted as part of the works or shipboard trials to confirm satisfactory operation of the complete engine. This includes satisfactory functioning on all fuel types on which the engine is to operate. See also *Pt 5, Ch 2, 11.4 Shipboard trials 11.4.7*.

11.3 Works trials (factory acceptance test)

11.3.1 The purpose of the works trials is to verify design parameters such as power, adherence to approved limits (e.g. maximum pressure) and functionality, and to establish reference values or base lines for later reference in the operational phase.

11.3.2 For each load point the parameters to be recorded include: Power and speed; Fuel index (or equivalent reading); Maximum combustion pressures; Exhaust gas temperature before turbine and from each cylinder (or from manifold, see Note 5 in *Table 2.7.1 Engines for propulsion purposes: Alarms and slow-downs*); Charge air temperature and pressure.

11.3.3 For all stages of the works trials the pertaining operation values are to be measured and recorded by the engine manufacturer. All results are to be compiled in an acceptance protocol to be issued by the engine manufacturer. Where the engine designer requires through life monitoring of crankshaft deflections, such measurements are also to be taken before and after works acceptance trials in accordance with the engine designer's requirements.

11.3.4 In each case given in *Table 2.11.1 Scope of works trials for engines*, all measurements conducted at the various load points are to be carried out at steady operating conditions. The readings for MCR, i.e. 100 per cent power (rated maximum continuous power at corresponding rpm) are to be taken twice at an interval of at least 30 minutes. For all load points provision should be made for time needed by the Surveyor to carry out visual inspections.

11.3.5 Calibration records for the instrumentation are, upon request, to be presented to the attending Surveyor.

Table 2.11.1 Scope of works trials for engines

Main engines driving propellers and waterjets		
Trial condition	Duration	Note
100% power (rated power) at rated engine speed, <i>R</i>	≥ 60 minutes	After having reached steady conditions
110% power at engine speed corresponding to 1,032 ^{*R}	30–45 minutes	After having reached steady conditions (1)
90% (or maximum continuous power), 75%, 50% and 25%	—	Powers in accordance with the nominal propeller curve
Starting and reversing manoeuvres	—	—
Testing of governor and independent overspeed protective device	—	See Pt 5, Ch 2, 7.2 Main engine governors
Shutdown device	—	See Pt 5, Ch 2, 7.4 Overspeed protective devices
Engines driving generators		
Trial condition	Duration	Note
100% power (rated power) at rated engine speed, <i>R</i>	≥ 50 minutes	After having reached steady conditions (2)
110% power	30 minutes	After having reached steady conditions (2) (3)
75%, 50% and 25% power and idle run	—	(2)
Start-up tests	—	—
Testing of governor and independent overspeed protective device	—	See Pt 5, Ch 2, 7.3 Auxiliary engine governors
Shutdown device	—	See Pt 5, Ch 2, 7.4 Overspeed protective devices
<p>Note 1. After running on the test bed, the fuel delivery system of main engines is normally to be so adjusted that overload power cannot be given in service.</p> <p>Note 2. The test is to be performed at rated speed with a constant governor setting.</p> <p>Note 3. After running on the test bed, the fuel delivery system of diesel engines driving generators must be adjusted such that overload (110%) power can be given in service after installation on board, so that the governing characteristics including the activation of generator protective devices can be fulfilled at all times.</p>		

11.3.6 Alternatives to the detailed tests may be agreed between the manufacturer and LR when the overall scope of tests is found to be equivalent. The scope of the trials may be expanded depending on the engine application, service experience, or other relevant reasons.

11.3.7 For electronically controlled engines:

- (a) integration tests in accordance with Pt 5, Ch 2, 1.2 Submission requirements 1.2.1; and
- (b) verification of engine configuration, see Pt 5, Ch 2, 4.3 Control engineering systems 4.3.2, and that the approved software quality plans, including the software configuration management process, are to be applied.

11.3.8 Checks of components to be presented for inspection after the works trials are left to the discretion of the Surveyor.

11.3.9 The Surveyor may require that after the trials the fuel delivery system is restricted so as to limit the engines to run at not more than 100 per cent power. The setting of the restriction is to be made as applicable to the intended fuel. Any restriction settings, and other changes to the engine's fuel injection equipment required for operation on special fuels, are to be recorded and included by the engine manufacturer.

11.3.10 For the duration of the acceptance test, no interventions or adjustments will be made to the machinery under test.

11.3.11 The testing of exhaust gas emissions is to comply with MARPOL as applicable.

11.4 Shipboard trials

11.4.1 The purpose of the shipboard testing is to verify compatibility with power transmission and driven machinery in the system, safety, control and auxiliary systems necessary for the engine and integration of engine/shipboard control systems, as well as other items that had not been dealt with in the FAT (Factory Acceptance Testing).

11.4.2 After installation on board, engines are to undergo shipboard trials as specified in *Table 2.11.2 Scope of shipboard trials for engines*. The scope of the trials may be expanded depending on the engine application, service experience or other relevant reasons, and is to be agreed between the LR Surveyor and the Shipyard prior to testing.

Table 2.11.2 Scope of shipboard trials for engines

Main engines driving fixed-pitch propellers (1) (2)		
Trial condition	Duration	Note
At rated engine speed, <i>R</i>	≥ 4 hours	–
At engine speed corresponding to normal continuous power	≥ 2 hours	–
At engine speed corresponding to 1,032* <i>R</i>	30 minutes	Where the engine adjustment permits, see <i>Pt 5, Ch 2, 11.3 Works trials (factory acceptance test) 11.3.10</i>
At minimum on-load speed	–	–
Starting and reversing manoeuvres	–	See <i>Pt 5, Ch 2, 9 Starting arrangements</i> and <i>Pt 5, Ch 2, 13 Air compressors</i>
In reverse direction of propeller rotation during the dock or sea trials at a minimum engine speed of 0,7* <i>R</i>	10 minutes	–
Control, monitoring, alarms and safety systems	–	Operation to be demonstrated
Where imposed, test to ensure engine can pass safely through barred speed range	–	–
Single engine driving a generator for propulsion only		
Trial condition	Duration	Note
100% power (rated propulsion power), see <i>Pt 5, Ch 2, 11.4 Shipboard trials 11.4.4</i>	≥ 4 hours	(3) (4)
At normal continuous propulsion power	≥ 2 hours	(3) (4)
110% power (rated propulsion power)	30 minutes	–
In reverse direction of propeller rotation at a minimum speed of 70% of the nominal propeller speed	10 minutes	(3) (4)
Starting manoeuvres	–	–
Control, monitoring, alarm and safety systems	–	Operation to be demonstrated
<p>Note 1. For main propulsion engines driving controllable pitch propellers, waterjets or reversing gears, the tests for main engines driving fixed-pitch propellers apply as appropriate.</p> <p>Note 2. Controllable pitch propellers are to be tested with various propeller pitches.</p> <p>Note 3. The tests are to be performed at rated speed with a constant governor setting.</p> <p>Note 4. Tests are to be based on the rated electrical powers of the electric propulsion motors.</p>		

11.4.3 Engines driving generators or important auxiliaries are to be subjected to an operational test for at least 4 hours. During the test, the set concerned is required to operate at its rated power for an extended period. It is to be demonstrated that the engine is capable of supplying 100 per cent of its rated power, and in the case of shipboard generating sets account shall be taken of the times needed to actuate the generator's overload protection system.

11.4.4 In addition to *Pt 5, Ch 2, 11.4 Shipboard trials 11.4.2*, for engines driving generators for electric propulsion motors as well as auxiliaries, an operational test is to be carried out of at least 4 hours duration at a load which corresponds to 100 per cent of the electric propulsion motor(s) rated power. The astern/ahead manoeuvring capability of the propulsion system is to be demonstrated.

11.4.5 Trials are to include demonstration of engine control, monitoring, alarm and safety system operation to confirm that they have been provided, installed and configured as intended and in accordance with the relevant requirements for main, auxiliary or emergency engines except items already verified during the works trials.

11.4.6 For electronically controlled engines:

- (a) shipboard tests in accordance with *Pt 5, Ch 2, 1.2 Submission requirements 1.2.1*; and
- (b) verification of engine configuration, see *Pt 5, Ch 2, 4.3 Control engineering systems 4.3.2*, and that the approved software quality plans, including the software configuration management process, are to be applied.

11.4.7 The suitability of an engine to burn residual or other special fuels is to be demonstrated where the machinery installation is arranged to burn such fuels in service. See also *Pt 6, Ch 1, 7.2 Unattended machinery space operation - UMS notation 7.2.1*.

11.4.8 For both manual and automatic engine control systems, acceleration and deceleration through any barred speed range, is to be demonstrated. The transit times are to be equal or less than the times stated in the approved documentation and are to be recorded. This also applies when passing through the barred speed range in reverse rotational direction, especially during the stopping test. The ship's draft and speed during all these demonstrations are to be recorded. Where a controllable pitch propeller is fitted, the pitch is also to be recorded.

11.4.9 The engine is to be checked for stable running (steady fuel index) at both upper and lower borders of the barred speed range. Steady fuel index means an oscillation range less than five per cent of the effective stroke (idle to full index).

■ Section 12 Turbochargers

12.1 General

12.1.1 Turbochargers are to be approved, either separately or as a part of an engine. The requirements are written for exhaust gas driven turbochargers, but apply in principle also for engine driven chargers.

12.1.2 Some requirements are reduced for turbochargers manufactured on the basis of mass production methods. Mass produced turbochargers are defined as those which are produced under the following criteria:

- (a) In quantity under strict quality control of material and parts, according to a quality assurance scheme acceptable to LR.
- (b) By the use of jigs and automatic machine tools designed to machine parts to specified tolerances for interchangeability, and which are verified on a regular inspection basis.
- (c) By assembly with parts taken from stock and requiring little or no fitting.
- (d) With bench tests carried out on individual assembled turbochargers according to a specified programme.
- (e) With appraisal by final examination of turbochargers selected at random after workshop testing.

12.1.3 Plans and particulars are to be submitted as required by *Pt 5, Ch 2, 1.2 Submission requirements 1.2.4*.

12.1.4 Alarms and slowdowns for turbochargers are required as listed in *Table 2.7.1 Engines for propulsion purposes: Alarms and slow-downs* and *Table 2.7.3 Auxiliary engines: Alarms and safeguards*.

12.1.5 Turbochargers are to be designed for the operating conditions defined in *Pt 5, Ch 1, 3 Operating conditions*. The component lifetime and the alarm level for speed are to be based on 45°C air inlet temperature.

12.1.6 A Type test, see *Pt 5, Ch 2, 14.2 Turbochargers*, is to be carried out on a standard unit taken from the assembly line and is to be witnessed by the Surveyor.

12.1.7 LR reserves the right to limit the duration of validity of approval of a mass produced turbocharger. LR is to be informed, without delay, of any change in the design of the turbocharger, in the manufacturing or control processes, in the selection of materials or in the list of subcontractors for main parts.

12.2 Dynamic balancing

12.2.1 All rotors are to be dynamically balanced on final assembly to the Surveyor's satisfaction.

12.3 Overspeed test

12.3.1 All fully bladed rotor sections and impeller/inducer wheels are to be overspeed tested for three minutes at either 20 per cent above the alarm level speed at room temperature, or 10 per cent above alarm level speed at 45°C inlet temperature when tested in the actual housing with the corresponding pressure ratio. The overspeed test may be waived for forged wheels that are individually controlled by an approved non-destructive method, this test will not be waived for wheels of the unit to be type tested.

12.4 Mechanical running test

12.4.1 Turbochargers are to be given a mechanical running test of 20 minutes duration at the maximum permissible speed.

12.4.2 Upon application, with details of an historical audit covering previous testing of turbochargers manufactured under an approved quality assurance scheme, consideration will be given to confining the test outlined in *Pt 5, Ch 2, 12.3 Overspeed test 12.3.1* to a representative sample of turbochargers.

12.5 Containment

12.5.1 In the event of any rotor burst, the turbocharger casing is to fully contain all debris and no part may penetrate the casing of the turbocharger or escape through the air intake.

12.5.2 Containment is to be demonstrated by testing which is to be fully documented. For approval of a generic range of turbochargers, subject to satisfactory performance, only the largest unit is required to be tested. In any case, it must be demonstrated (e.g. by calculation) that the selected test unit is representative for the whole generic range.

12.5.3 The minimum test speeds for rotor burst testing is to be the same as those required for the overspeed test specified in *Pt 5, Ch 2, 12.3 Overspeed test 12.3.1*.

12.5.4 Containment tests are to be performed at working temperature.

12.5.5 Calculations using a simulation model and numerical analysis to demonstrate the required containment may be accepted in lieu of the practical containment test, provided that:

- (a) The numerical simulation model has been validated and its suitability/accuracy has been proven by direct comparison between calculation results and the practical containment test for a reference application (reference containment test). This test is to be performed at least once by the manufacturer for acceptance of the numerical simulation method in lieu of tests.
- (b) The corresponding numerical simulation for the containment is performed for the same speeds as specified for the containment test.
- (c) Material properties for high-speed deformations are to be applied in the numeric simulation. The correlation between normal properties and the properties at the pertinent deformation speed are to be substantiated.
- (d) The design of the turbocharger regarding geometry and kinematics is similar to the turbocharger that was used for the reference containment test. In general, totally new designs will call for a new reference containment test.

12.6 Disk-Shaft shrinkage fit

12.6.1 For turbochargers where the disc is connected to the shaft with an interference fit, calculations are to substantiate safe torque transmission during all relevant operating conditions such as maximum speed, maximum torque and maximum temperature gradient combined with minimum shrinkage amount.

12.7 Works testing and inspection

12.7.1 LR Surveyors are to be provided with free access to the manufacturer's works to inspect at random the quality control measures and to witness the tests required by *Pt 5, Ch 2, 12.7 Works testing and inspection 12.7.3* to *Pt 5, Ch 2, 12.7 Works testing and inspection 12.7.7* as deemed necessary, and to have free access to all control records and subcontractor's certificates.

12.7.2 Each individual unit is to be tested in accordance with *Pt 5, Ch 2, 12.7 Works testing and inspection 12.7.4* to *Pt 5, Ch 2, 12.7 Works testing and inspection 12.7.7*.

12.7.3 Rotating parts of the turbocharger's blower are to be marked for easy identification with the corresponding certificate. Component identification is to be in accordance with the Rules for Materials.

12.7.4 Material tests, inspection, NDE and certification of the rotating parts and casing are to be in accordance with the requirements of the Rules for Materials as applicable.

12.7.5 Pressure tests are to be carried out in accordance with *Table 2.2.1 Test and certification requirements for engine components*. Special consideration will be given where design or testing features may require modification of the test requirements.

12.7.6 Dynamic balancing and overspeed tests are to be carried out, see *Pt 5, Ch 2, 12.2 Dynamic balancing* and *Pt 5, Ch 2, 12.3 Overspeed test*.

12.7.7 A mechanical running test is to be carried out, see *Pt 5, Ch 2, 12.4 Mechanical running test*. The duration of the running test may be reduced to 10 minutes provided that the manufacturer is able to verify the distribution of defects established during the running tests on the basis of a sufficient number of tested turbochargers. For manufacturers who have facilities in their works for testing the turbochargers on an engine for which the turbochargers are intended, the bench test may be replaced by a test run of 20 minutes at overload (110 per cent of the rated output) on this engine.

12.8 Certification

12.8.1 The manufacturer is to adhere to a quality system designed to ensure that the designer's specifications are met, and that manufacturing is in accordance with the approved drawings.

12.8.2 Turbochargers are to be delivered with:

- (a) For turbochargers manufactured using mass production methods as defined in *Pt 5, Ch 2, 12.1 General 12.1.2*, a manufacturer's certificate, that at a minimum cites the applicable type approval, including production assessment.
- (b) For all other turbochargers, an LR certificate, that at a minimum cites the applicable type approval and the LR Quality Scheme when applicable.

12.8.3 Where the manufacturer is approved under the LR Quality Assurance for Machinery Scheme (QAM), the audits will include specific focus on:

- (a) Chemical composition of material for the rotating parts.
- (b) Mechanical properties of the material of a representative specimen for the rotating parts and the casing.
- (c) UT and crack detection of rotating parts.
- (d) Dimensional inspection of rotating parts.
- (e) Rotor dynamic balancing.
- (f) Hydraulic testing of cooling spaces in accordance with *Table 2.2.1 Test and certification requirements for engine components*.
- (g) Overspeed test of all compressor disks as per *Pt 5, Ch 2, 12.3 Overspeed test 12.3.1*.

■ Section 13 Air compressors

13.1 General requirements

13.1.1 The requirements of this Section are applicable to reciprocating air compressors intended for starting main engines and auxiliary engines providing essential services.

13.1.2 Two or more air compressors are to be fitted having a total capacity, together with a topping-up compressor where fitted, capable of charging the air receivers within 1 hour from atmospheric pressure, to the pressure sufficient for the number of starts required by *Pt 5, Ch 2, 9.2 Air receiver capacity*. At least one of the air compressors is to be independent of the main propulsion unit and the capacity of the main air compressors is to be approximately equally divided between them. The capacity of an emergency compressor which may be installed to satisfy the requirements of *Pt 5, Ch 2, 9.1 Dead ship condition starting arrangements* is to be ignored.

13.1.3 The compressors are to be so designed that the temperature of the air discharged to the starting air receivers will not substantially exceed 93°C in service. A small fusible plug or an alarm device operating at 121°C is to be provided on each compressor to give warning of excessive air temperature. The emergency air compressor is excepted from these requirements.

13.1.4 Each compressor is to be fitted with a safety valve so proportioned and adjusted that the accumulation with the outlet valve closed will not exceed 10 per cent of the maximum working pressure. The casings of the cooling water spaces are to be fitted with a safety valve or bursting disc so that ample relief will be provided in the event of the bursting of an air cooler tube. It is recommended that compressors be cooled by fresh water.

13.2 Plans and particulars

13.2.1 Detailed plans, particulars, dimensional drawings and material specifications for compressor crankshafts are to be submitted in triplicate. Plans and particulars for other parts and calculations where applicable are to be submitted to LR upon request.

13.2.2 Where compressors of a special type or design are proposed, the requirements of *Pt 7, Ch 15 Refrigeration Systems and Equipment Serving Provision Stores and Air-Conditioning Installations* are to be applied.

13.3 Materials

13.3.1 The specified minimum tensile strength of castings and forgings for compressor crankshafts are to be within the limits given in *Pt 5, Ch 2, 2.1 Crankshaft Materials 2.1.1* and for grey cast iron to be not less than 300 N/mm².

13.3.2 Where it is proposed to use materials outside the ranges specified in *Pt 5, Ch 2, 13.3 Materials 13.3.1*, details of the chemical composition, heat treatment and mechanical properties are to be submitted for approval.

13.3.3 For compressors crankshafts with a calculated crank pin diameter equal to or greater than 50 mm, materials for components are to be tested as indicated in *Pt 5, Ch 2, 2.2 Material test and inspections*. For calculated crank pin diameters less than 50 mm, a manufacturers' certificate may be accepted, see *Ch 1, 3.1 General 3.1.3* of the Rules for Materials.

13.4 Design and Construction

13.4.1 A fully documented fatigue strength analysis is to be submitted indicating a factor of safety of 1,5 at the design loads based on a suitable fatigue strength criterion. Alternatively, the requirements of *Pt 5, Ch 2, 13.4 Design and Construction 13.4.2* may be used.

13.4.2 The diameter, d_p , of a compressor crankshaft is to be not less than d , determined by the following formula, when all cranks on the shaft are located between two main bearings only:

$$d = V_c \left(\frac{D^2 p Z}{78,5} \left(\frac{S}{16} + \frac{ab}{a+b} \right) \right)^{1/3} \text{ mm}$$

= where

a = distance between inner edge of one main bearing and the centreline of the crankpin nearest the centre of the span, in mm

b = distance from the centreline of the same crankpin to the inner edge of the adjacent main bearing, in mm

a+b = span between inner edges of main bearings, in mm

d_p = proposed minimum diameter of crankshaft, in mm

p = design pressure, in bar g, as defined in *Pt 5, Ch 12, 1.3 Design symbols 1.3.1*

D = diameter of cylinder, in mm

S = length of stroke, in mm

V_c = 1,0 for shafts having one cylinder per crank, or

= 1,05 for 90°	}	between adjacent
= 1,18 for 60°		cylinders on the
= 1,25 for 45°		same crankpin

for the shaft and cylinder arrangements as detailed in *Table 2.13.1 Angle between cylinders*

$$Z = \frac{560}{\sigma_u + 160} \text{ for steel}$$

$$Z = \frac{700}{\sigma_u + 260 - 0,059d_p} \text{ for spheroidal or nodular graphite cast iron}$$

$$Z = \frac{700}{\sigma_u + 260 - 0,069d_p} \text{ for grey cast iron}$$

σ_u = specified minimum tensile strength of crankshaft material, in N/mm².

Table 2.13.1 Angle between cylinders

Number of crankpins	Number of cylinders per crank	Angle between cylinders, in degrees		
1 or 2	2	45	60	90
3	2	45	60	—
4	2	45	60	—
1	3	45	60	90
2	3	45	60	—
3	3	45	—	—
1	4	45	60	—
2	4	45	—	—

13.4.3 Where the shaft is supported additionally by a centre bearing, the diameter is to be evaluated from the half shaft between the inner edges of the centre and outer main bearings. The diameter so found for the half shaft is to be increased by six per cent for the full length shaft diameter.

13.4.4 The dimensions of crankwebs are to be such that Bt^2 is to be not less than given by the following formulae:

$0,4d^3$ for the web adjacent to the bearing

$0,75d^3$ for intermediate webs

= where

B = breadth of web, in mm

d = minimum diameter of crankshaft as required by Pt 5, Ch 2, 13.4 Design and Construction 13.4.2, in mm

t = axial thickness of web which is to be not less than $0,45d$ for the web adjacent to the bearing, or $0,60d$ for intermediate webs, in mm.

13.4.5 Fillets at the junction of crankwebs with crankpins or journals are to be machined to a radius not less than $0,05d$. Smaller fillets, but of a radius not less than $0,025d$, may be used provided the diameter of the crankpin or journal is not less than cd ,

= where

c = $1,1 - 2 \frac{r}{d}$ but to be taken as not less than 1,0

d = minimum diameter of crankshaft as required by Pt 5, Ch 2, 13.4 Design and Construction 13.4.2, in mm

r = fillet radius, in mm.

13.4.6 Fillets and oil holes are to be rounded to an even contour and smooth finish.

13.4.7 An oil level sight glass or oil level indicator is to be fitted to the crankcase.

13.4.8 The crankcases of compressors are to be designed to withstand a pressure equal to the maximum working pressure of the system.

13.4.9 Compressors with shaft power exceeding 500 kW are to have torsional vibration analysis determined in accordance with Pt 5, Ch 8, 2 Torsional vibration as applicable.

13.4.10 The cooler dimensions for sea-water cooled stage air coolers are to be based on an inlet temperature of not less than 32°C. Where fresh water cooling is used, the cooling water inlet temperature is not to be greater than 40°C.

13.4.11 The cooler dimensions for air cooled stage air coolers are to be based on an air temperature of not less than 45°C.

13.4.12 The piping to and from the air compressor is to be arranged to prevent condensation from entering the cylinders.

13.5 Testing

13.5.1 Cylinders and liners of air compressors are to be subjected to hydraulic pressure tests at 1,5 times the final pressure of the stage concerned.

13.5.2 The compressed air chambers of the intercoolers and after coolers of air compressors are to be subjected to hydraulic pressure tests at 1,5 times the final pressure of the stage concerned.

13.6 Safety arrangements and monitoring

13.6.1 Air compressors are to be arranged and located so as to minimise the intake of air contaminated by oil or water.

13.6.2 Where one compressor stage comprises several cylinders which can be shut off individually, each cylinder shall be equipped with a safety valve and a pressure gauge.

13.6.3 After the final stage, all air compressors are to be equipped with a water trap and after cooler. The water traps, after coolers and the compressed air spaces between the stages are to be provided with discharge devices at their lowest points.

13.6.4 Each compressor stage shall be fitted with a suitable pressure gauge, the scale of which must indicate the relevant maximum permissible working pressure.

13.7 Crankcase relief valves

13.7.1 In compressors having cylinders not exceeding 200 mm bore or having a crankcase gross volume not exceeding 0,6 m³, crankcase relief valves may be omitted.

13.7.2 Crankcases are to be provided with lightweight spring-loaded valves or other quick-acting and self-closing devices to relieve the crankcases of pressure in the event of an internal explosion and to prevent any inrush of air thereafter. The valves are to be designed and constructed to open quickly and be fully open at a pressure not greater than 0,2 bar.

13.7.3 The valve lids are to be made of ductile material capable of withstanding the shock of contact with stoppers at the full open position.

13.7.4 Each valve is to be fitted with a flame arrester that permits flow for crankcase pressure relief and prevents the passage of flame following a crankcase explosion.

13.7.5 The valves are to be provided with a copy of the manufacturer's installation and maintenance manual for the size and type of valve being supplied. The manual is to contain the following information:

- (a) Description of valve with details of function and design limits.
- (b) Copy of type test certification.
- (c) Installation instructions.
- (d) Maintenance and in-service instructions to include testing and renewal of any sealing arrangements.
- (e) Actions required after a crankcase explosion.

13.7.6 A copy of the installation and maintenance manual required by *Pt 5, Ch 2, 13.7 Crankcase relief valves 13.7.3* is to be provided on board the ship.

13.7.7 Plans showing details and arrangements of the crankcase relief valves are to be submitted for approval, see *Pt 5, Ch 2, 1.2 Submission requirements*.

13.7.8 The valves are to be provided with suitable markings that include the following information:

- (a) Name and address of manufacturer.
- (b) Designation and size.
- (c) Month/Year of manufacture.
- (d) Approved installation orientation.

13.8 Number of crankcase relief valves

13.8.1 In compressors having cylinders exceeding 200 mm but not exceeding 250 mm bore, at least two relief valves are to be fitted; where more than one relief valve is required, the valves are to be located at or near the ends of the crankcase.

13.8.2 In compressors having cylinders exceeding 250 mm but not exceeding 300 mm bore, at least one relief valve is to be fitted in way of each alternate crank throw with a minimum of two valves. For compressors having 3, 5, 7, 9, etc. crank throws, the number of relief valves is not to be less than 2, 3, 4, 5, etc. respectively.

13.8.3 In compressors having cylinders exceeding 300 mm bore, at least one valve is to be fitted in way of each main crank throw.

13.8.4 Additional relief valves are to be fitted for separate spaces on the crankcase, such as gear or chain cases, when the gross volume of such spaces exceeds 0,6 m³.

13.9 Size of crankcase relief valves

13.9.1 The combined free area of the crankcase relief valves fitted on a compressor is to be not less than 115 cm²/m³ based on the volume of the crankcase.

13.9.2 The free area of each relief valve is to be not less than 45 cm².

13.9.3 The free area of the relief valve is the minimum flow area at any section through the valve when the valve is fully open.

13.9.4 In determining the volume of the crankcase for the purpose of calculating the combined free area of the crankcase relief valves, the volume of the stationary parts within the crankcase may be deducted from the total internal volume of the crankcase.

13.10 Vent pipes

13.10.1 Where crankcase vent or breather pipes are fitted, they are to be made as small as practicable and/or as long as possible to minimise the inrush of air after an explosion.

■ Section 14 Type testing – General

14.1 Engines

14.1.1 New engine types or developments of existing types are to be subjected to an agreed programme of type testing to complement the design appraisal and review of documentation.

14.1.2 Requirements for type testing of engines are contained within the Lloyd's Register Type Approval System, Test Specification No. 4 – *Reciprocating Internal Combustion Engines and Associated Ancillary Equipment*. In all cases the type test specification is to be agreed with LR.

14.1.3 Type testing specifications for other auxiliary systems are to be submitted for approval if they are to be tested separately from the engine.

14.1.4 Wherever practical, type tests are to be conducted with the engine control systems operational in the approved configuration, see *Pt 5, Ch 2, 1.2 Submission requirements* and *Pt 5, Ch 2, 4.3 Control engineering systems 4.3.2*. Configuration management documents that satisfy the requirements of ISO 10007 or an equivalent national or international standard, are to be reviewed at testing for validity and referenced in the type test report.

14.1.5 In addition to type testing against the requirements of Test Specification No. 4, engines may also be submitted for approval against recognised international or national standards. Where this additional testing and appraisal is carried out satisfactorily it will be stated on the Type Approval Certificate.

14.2 Turbochargers

14.2.1 Requirements for type testing of turbochargers are contained within the Lloyd's Register Type Approval System, Test Specification No. 4 – *Reciprocating Internal Combustion Engines and Associated Ancillary Equipment*. In all cases the type test specification is to be agreed with LR.

14.3 Crankcase explosion relief valves

14.3.1 Requirements for type testing of crankcase explosion relief valves are contained within the Lloyd's Register Type Approval System, Test Specification No. 4 – *Reciprocating Internal Combustion Engines and Associated Ancillary Equipment*. In all cases the type test specification is to be agreed with LR.

14.3.2 The test specification is only applicable to explosion relief valves fitted with flame arresters. Where internal oil wetting of a flame arrester is a design feature of an explosion relief valve, alternative testing arrangements that demonstrate compliance with

these requirements may be proposed by the manufacturer. The alternative testing arrangements are to be submitted to LR for appraisal.

14.4 Crankcase oil mist detection system

14.4.1 Requirements for type testing of crankcase oil mist detection systems are contained within the Lloyd's Register Type Approval System, *Test Specification No. 4 – Reciprocating Internal Combustion Engines and Associated Ancillary Equipment*. In all cases the type test specification is to be agreed with LR.

14.4.2 This test specification is also applicable to oil mist detection systems intended for gear cases.

14.4.3 The approval of one type of detection equipment may be used to qualify other devices having identical construction details. Proposals are to be submitted for consideration.

14.4.4 Acceptance of crankcase oil mist detection equipment is at the discretion of LR based on the appraisal of plans and particulars and the test house report of the results of type testing. *See Pt 5, Ch 2, 1.2 Submission requirements 1.2.6.*



Cross-references

The pumping arrangements, including cooling water and lubricating oil systems, are to comply with the requirements of *Pt 5, Ch 14 Machinery Piping Systems*.

For spare gear, see *Pt 5, Ch 1, 7 Spare gear for machinery installations*.

*Section***Scope**

- 1 **Plans and particulars**
 - 2 **Materials**
 - 3 **Design and construction**
 - 4 **Safety arrangements**
 - 5 **Emergency arrangements**
 - 6 **Control and monitoring of main and auxiliary steam turbines**
 - 7 **Tests and equipment**
 - 8 **Cross-references**
-

■ **Scope**

The requirements of this Chapter are applicable to steam turbines for main propulsion and also, where powers exceed 110 kW (150 shp), to those for essential auxiliary services.

■ *Section 1*
Plans and particulars

1.1 Plans

1.1.1 The following plans are to be submitted for consideration, together with particulars of materials, maximum shaft powers and revolutions per minute, see *Pt 5, Ch 1, 3.3 Power ratings*. The pressures and temperatures applicable at maximum shaft power and under the emergency conditions of *Pt 5, Ch 3, 5.2 Single screw ships* are to be stated or indicated on the plans.

- General arrangement.
- Sectional assembly.
- Rotors and couplings.
- Casings.

1.1.2 For the emergency conditions of *Pt 5, Ch 3, 5.3 Single main boiler*, full particulars of the means proposed for emergency propulsion are to be submitted.

1.1.3 Where rotors and castings are of welded construction, details of the welded joints are also to be submitted for consideration.

1.1.4 In general, plans for auxiliary turbines need not be submitted.

■ Section 2 Materials

2.1 General

2.1.1 In the selection of materials, consideration is to be given to their creep strength, corrosion resistance and scaling properties at working temperatures to ensure satisfactory performance and long life under service conditions.

2.1.2 Grey cast iron is not to be used for temperatures exceeding 260°C.

2.2 Materials for forgings

2.2.1 Turbine rotors and discs are to be of forged steel. For carbon and carbon-manganese steel forgings, the specified minimum tensile strength is to be selected within the limits of 400 and 600 N/mm² (41 and 61 kgf/mm²). For alloy steel rotor forgings, the specified minimum tensile strength is to be selected within the limits of 500 and 800 N/mm² (51 and 82 kgf/mm²). For discs and other alloy steel forgings, the specified minimum tensile strength is to be selected within the limits of 500 and 1000 N/mm² (51 and 102 kgf/mm²).

2.2.2 For alloy steels, details of the proposed chemical composition, heat treatment and mechanical properties are to be submitted for approval.

2.2.3 When it is proposed to use material of higher tensile strength, full details are to be submitted for approval.

■ Section 3 Design and construction

3.1 General

3.1.1 In the design and arrangement of turbine machinery, adequate provision is to be made for the relative thermal expansion of the various turbine parts, and special attention is to be given to minimising casing and rotor distortion under all operating conditions.

3.1.2 Turbine bearings are to be so disposed and supported that lubrication is not adversely affected by heat flow from adjacent hot parts of the turbine. Effective means are to be provided for intercepting oil leakage and preventing oil from reaching high temperature glands and casings and steam pipes. Drainage openings and drain pipes from oil baffle pockets are to be sufficiently large to prevent excessive accumulation and leakage of oil.

3.2 Welded components

3.2.1 Turbine rotors, cylinders and associated components fabricated by means of welding will be considered for acceptance if constructed by firms whose works are properly equipped to undertake welding to equivalent standards, for rotors and cylinders respectively, to those required by the Rules for Class 1 and Class 2/1 welded pressure vessels, see Pt 5, Ch 17, 1 General to Pt 5, Ch 17, 6 Non-Destructive Examination.

3.2.2 Welding is to be carried out in accordance with the requirements of Ch 13, 4 Specific requirements for fusion welded pressure vessels of the Rules for Materials, using welding procedures and welders that have been qualified in accordance with Ch 12 Welding Qualifications of the Rules for Materials.

3.2.3 Before work is commenced, manufacturers are to submit for consideration details of proposed welding procedures and their proposals for routine examination of joints by non-destructive means.

3.2.4 Materials used in the construction of turbine rotors, cylinders, diaphragms, condensers, etc. are to be of welding quality.

3.2.5 Where it is proposed to construct rotors from two or more forged components joined by welding, full details of the chemical composition, mechanical properties and heat treatment of the materials, together with particulars of the welding consumables, an outline of the welding procedure, method of fabrication and heat treatment, are to be submitted for consideration.

3.2.6 Joints in rotors and major joints in cylinders are to be designed as full-strength welds and for complete fusion of the joint.

3.2.7 Adequate preheating is to be employed for mild steel cylinders and components and where the metal thickness exceeds 44 mm, and for all low alloy steel cylinders and components and for any part where necessitated by joint restraint.

3.2.8 Stress relief heat treatment is to be applied to all cylinders and associated components on completion of the welding of all joints and attached structures. For details of stress relief procedure, temperature and duration, see *Ch 13, 4.11 Basic requirements for post-weld heat treatment of fusion welded pressure vessels* of the Rules for Materials.

3.2.9 For all welded components, weld procedure tests are to be in accordance with *Ch 12, 2.7 Destructive tests for steel butt welds* of the Rules for Materials.

3.2.10 Production weld tests are to be performed according to the requirements of *Ch 13, 4.5 General requirements for routine weld production tests* of the Rules for Materials.

3.3 Stress raisers

3.3.1 Smooth fillets are to be provided at abrupt changes of section of rotors, spindles, discs, blade roots and tenons. The rivet holes in blade shrouds are to be rounded and radiused on top and bottom surfaces, and tenons are to be radiused at their junction with blade tips. Balancing holes in discs are to be well rounded and polished.

3.3.2 Surveyors are to be satisfied as to the workmanship and riveting of blades to shroud bands, and that the blade tenons are free from cracks, particularly with high tensile blade material. Test samples are to be sectioned and examined, and pull-off tests made if considered necessary by the Surveyors.

3.4 Shrunk-on rotor discs

3.4.1 Main turbine rotor discs fitted by shrinking are to be secured with keys, dowels or other approved means.

3.5 Vibration

3.5.1 Care is to be taken in the design and manufacture of turbine rotors, rotor discs and blades to ensure freedom from undue vibration within the operating speed range. Consideration of blade vibration should include the effect of centrifugal force, blade root fixing, metal temperature and disc flexibility where appropriate.

3.5.2 For the vibration and alignment of main propulsion systems formed by the turbines geared to the line shafting, see *Pt 5, Ch 8 Shaft Vibration and Alignment*.

3.6 External influences

3.6.1 Pipes and ducts connected to turbine casings are to be so designed that no excessive thrust loads or moments are applied by them to the turbines. Gratings and any fittings in way of sliding feet or flexible-plate supports are to be so arranged that casing expansion is not restricted. Where main turbine seatings incorporate a tank structure, consideration is to be given to the temperature variation of the tank in service to ensure that turbine alignment will not be adversely affected.

3.7 Steam supply and water system

3.7.1 In the arrangement of the gland sealing system, the pipes are to be made self-draining and every precaution is to be taken against the possibility of condensed steam entering the glands and turbines. The steam supply to the gland sealing system is to be fitted with an effective drain trap. In the air ejector re-circulating water system, the connection to the condenser is to be so located that water cannot impinge on the L.P. rotor or casing.

3.8 Turning gear

3.8.1 Turning gear is to be provided for all turbines to facilitate operating and maintenance regimes as required by the manufacturer.

3.8.2 The turning gear for all propulsion turbines is to be power-driven and if electric, is to be continuously rated.

3.8.3 The turning gear for auxiliary turbines may be hand operated (manual) except where this is not practicable, in which case the provision of *Pt 5, Ch 3, 3.8 Turning gear 3.8.2* is to be complied with.

3.8.4 The turning gear for all turbines is to be fitted with safety interlocks which prevent steam valve actuation for turbine operation when engaged, see *Pt 5, Ch 1, 3.9 Astern power*. Indication of engaged / not engaged is to be provided at all start positions.

3.8.5 The remote control device of power-driven turning gear is to be so designed that power is removed from the turning gear when the operating switch is released.

3.8.6 Means are to be provided to secure the turning gear when disengaged.

■ Section 4 Safety arrangements

4.1 Low vacuum and overpressure protective devices

4.1.1 In order to provide a warning, due to excessive pressure, to personnel in the vicinity of the exhaust ends of main turbines, sentinel relief valves are to be provided at the exhaust ends or other approved positions. The relief valve discharge outlets are to be visible and suitably guarded if necessary. Where a low vacuum cut-out device is provided, the sentinel relief valve at the L.P. exhaust may be omitted.

4.1.2 In order to provide a warning, due to excessive pressure, to personnel in the vicinity of the exhaust ends of auxiliary turbines, sentinel relief valves are to be provided at the exhaust ends. The relief valve discharge outlets are to be visible and suitably guarded if necessary. Low vacuum or overpressure cut-out devices, as appropriate, are also to be provided for auxiliary turbines not installed with their own condensers.

4.2 Bled steam connections

4.2.1 Non-return or other means, which will prevent steam and water returning to the turbines, are to be fitted in bled steam connections.

4.3 Steam strainers

4.3.1 Efficient steam strainers are to be provided close to the inlets to ahead and astern high pressure turbines, or alternatively at the inlets to the manoeuvring valves.

■ Section 5 Emergency arrangements

5.1 Lubricating oil failure

5.1.1 Arrangements are to be made for the steam to the ahead propulsion turbines to be automatically shut off in the event of failure of the lubricating oil pressure; however, steam is to be made available at the astern turbine for braking purposes in such an emergency, see *Pt 5, Ch 14 Machinery Piping Systems* for emergency oil supply.

5.1.2 Auxiliary turbine arrangements are to be such that steam supply is automatically shut-off in the event of failure of the lubricating oil pressure.

5.2 Single screw ships

5.2.1 In single screw ships fitted with cross compound steam turbine installations in which two or more turbines are separately coupled to the same main gear wheel, the arrangements are to be such as to enable safe navigation when the steam supply is led direct to the L.P. turbine and either the H.P or L.P. turbine can exhaust direct to the condenser. Adequate arrangements and controls are to be provided for these emergency operating conditions so that the pressure and temperature of the steam will not exceed those which the turbines and condenser can safely withstand.

5.2.2 The necessary pipes and valves or fittings for these arrangements are to be readily available and properly marked. A fit up test of all combinations of pipes and valves is to be performed prior to the first sea trials.

5.2.3 The permissible power/speeds of the operating turbines(s) when operating without one of the turbines (all combinations) is to be specified and information provided on board.

5.2.4 The operation of the turbines under emergency conditions is to be assessed for the potential influence on shaft alignment and gear teeth loading conditions.

5.3 Single main boiler

5.3.1 Ships intended for unrestricted service, fitted with steam turbines and having a single main boiler, are to be provided with means to ensure emergency propulsion in the event of failure of the main boiler.

■ Section 6

Control and monitoring of main and auxiliary steam turbines

6.1 General

6.1.1 Control engineering systems are to be in accordance with the requirements of *Pt 6, Ch 1 Control Engineering Systems*.

6.1.2 All main and auxiliary steam turbines intended for essential services are to be provided with means of indicating the lubricating oil pressure supply to them. Where such turbines are of more than 37 kW (50 shp), audible and visual alarms are to be fitted to give warning of an appreciable reduction in pressure of the lubricating oil supply. Further, these alarms are to be actuated from the outlet side of any restrictions, such as filters, coolers, etc.

6.2 Overspeed protective devices

6.2.1 An overspeed protective device is to be provided for main and auxiliary turbines to shut off the steam automatically and prevent the maximum designed speed being exceeded by more than 15 per cent.

6.2.2 Where two or more turbines of a compound main turbine installation are separately coupled to the same main gear wheel, and one overspeed protective device is provided, this is to be fitted to the L.P. ahead turbine. Hand trip gear for shutting off the steam in an emergency is to be provided at the manoeuvring platform.

6.3 Speed governors

6.3.1 Where a turbine installation incorporates a reverse gear, electric transmission or reversible propeller, a speed governor in addition to, or in combination with, the overspeed protective device is to be fitted, and is to be capable of controlling the speed of the unloaded turbine without bringing the overspeed protective device into action.

6.3.2 Auxiliary turbines intended for driving electric generators are to be fitted with speed governors which, with fixed settings, are to control the speed within 10 per cent momentary variation and 5 per cent permanent variation when full load is suddenly taken off or put on. The permanent speed variations of alternating current machines intended for parallel operations are to equalise within a tolerance of $\pm 0,5$ per cent.

6.4 Unattended machinery

6.4.1 Where machinery steam turbines are fitted with automatic or remote controls so that under normal operating conditions they do not require any manual intervention by the operators, they are to be provided with the alarms and safety arrangements required by *Pt 5, Ch 3, 6.4 Unattended machinery* to *Pt 5, Ch 3, 6.6 Auxiliary steam turbines*, as appropriate. Alternative arrangements which provide equivalent safeguards will be considered.

6.4.2 Where machinery is arranged to start automatically or from a remote control station, interlocks are to be provided to prevent start-up under conditions which could hazard the machinery.

6.4.3 Where machinery specified in this Section is required to be provided with a standby pump, the standby pump is to start automatically if the discharge pressure from the working pumps falls below a predetermined value.

6.4.4 Where a first stage alarm together with a second stage alarm and automatic shutdown of machinery are required in the relevant Tables of this Section, the sensors and circuits utilised for the second stage alarm and automatic shutdown are to be independent of those required for the first stage alarm.

6.5 Steam turbine machinery for propulsion purposes

6.5.1 Alarms and safeguards are indicated in *Pt 5, Ch 3, 6.5 Steam turbine machinery for propulsion purposes 6.5.2 to Pt 5, Ch 3, 6.5 Steam turbine machinery for propulsion purposes 6.5.6* and *Table 3.6.1 Steam turbine machinery: Alarms and safeguards*.

Table 3.6.1 Steam turbine machinery: Alarms and safeguards

Item	Alarm	Note
Lubricating oil pressure	1st stage low	—
	2nd stage low	Automatic shutdown, see <i>Pt 5, Ch 3, 6.4 Unattended machinery 6.4.4</i>
Lubricating oil temperature	High	—
Lubricating oil sump level	Low	—
Lubricating oil filters differential pressure	High	—
Bearing temperatures or bearing oil outlet temperature	High	—
Astern turbine temperature	High	—
Gland steam pressure	High and Low	—
Thrust bearing temperature	High	—
Sea-water pressure or flow	Low	—
Turbine vibration	High	—
Axial movement of turbine rotor	High	Shutdown or speed reduction or turbine(s)
Main condenser vacuum	Low	—
Main condenser condensate level	High	—
Overspeed	High	See <i>Pt 5, Ch 3, 6.2 Overspeed protective devices</i>

6.5.2 Audible and visual alarms are to operate, and indication is to be given at the relevant control stations to stop or reduce the speed of the turbine(s) for the following fault conditions:

- (a) Excessive turbine vibration.
- (b) Excessive axial movement of turbine rotor.
- (c) Low vacuum in main condenser.
- (d) High condensate level in main condenser.

6.5.3 Reduction of speed may be effected by either manual or automatic control.

6.5.4 Means are to be provided to prevent the risk of thermal distortion of the turbines, by automatic steam spinning, when the shaft is stopped in the manoeuvring mode. An audible and visual alarm is to be provided at the relevant control stations when the shaft has been stopped for a predetermined time.

6.5.5 The following turbine services are to be fitted with automatic controls so as to maintain steady state conditions throughout the normal operating range of the propulsion turbine(s):

- (a) Lubricating oil supply temperature.
- (b) Condenser condensate level.
- (c) Gland steam pressure.

6.5.6 Prolonged running in a restricted speed range is to be prevented automatically, or alternatively, indication of restricted speed ranges is to be provided at each control station.

6.6 Auxiliary steam turbines

6.6.1 Alarms and safeguards are indicated in *Table 3.6.2 Auxiliary engines and auxiliary steam turbines: Alarms and safeguards*

Table 3.6.2 Auxiliary engines and auxiliary steam turbines: Alarms and safeguards

Item	Alarm	Note
Lubricating oil inlet temperature	High	—
Lubricating oil inlet pressure	1st stage low	—
	2nd stage low	Automatic shutdown of turbine, see Pt 5, Ch 3, 6.4 Unattended machinery 6.4.4
Condenser vacuum	Low	Automatic shutdown of turbine, see Pt 5, Ch 3, 6.4 Unattended machinery 6.4.4
Axial displacement of rotor	High	Automatic shutdown of turbine, see Pt 5, Ch 3, 6.4 Unattended machinery 6.4.4
Overspeed	High	See Pt 5, Ch 4, 4 Design and construction

■ *Section 7*
Tests and equipment

7.1 Stability testing of turbine rotors

7.1.1 All solid forged H.P. turbine rotors intended for main propulsion service where the inlet steam temperature exceeds 400°C are to be subjected to at least one thermal stability test. This requirement is also applicable to rotors constructed from two or more forged components joined by welding. The test may be carried out at the forge or turbine builders' works:

- (a) after heat treatment and rough machining of the forging; or
- (b) after final machining; or
- (c) after final machining and blading of the rotor.

The stabilising test temperature is to be not less than 28°C above the maximum steam temperature to which the rotor will be exposed, and not more than the tempering temperature of the rotor material. For details of a recommended test procedure and limits of acceptance, see *Rules for the Manufacture, Testing and Certification of Materials, July 2015*. Other test procedures may be adopted if approved.

7.1.2 Where main turbine rotors are subjected to thermal stability tests at both forge and turbine builders' works, the foregoing requirements are applicable to both tests. It is not required that auxiliary turbine rotors be tested for thermal stability, but, if such tests are carried out, the requirement for main turbine rotors will be generally applicable.

7.2 Balancing

7.2.1 All rotors as finished-bladed and complete with half-coupling are to be dynamically balanced to the Surveyor's satisfaction, in a machine of sensitivity appropriate to the size of rotor.

7.3 Hydraulic tests

7.3.1 Manoeuvring valves are to be tested to twice the working pressure. The nozzle boxes of impulse turbines are to be tested to 1,5 times the working pressure.

7.3.2 The cylinders of all turbines are to be tested to 1,5 times the working pressure in the casing, or to 2,0 bar (2,0 kgf/cm²), whichever is the greater.

7.3.3 For test purposes, the cylinders may be sub-divided with temporary diaphragms for distribution of test pressures.

7.3.4 Condensers are to be tested in the steam space to 1,0 bar (1,0 kgf/cm²). The water space is to be tested to the maximum pressure which the pump can develop at ship's full draught with the discharge valve closed plus 0,7 bar (0,7 kgf/cm²), with a minimum test pressure of 2,0 bar (2,0 kgf/cm²). Where the operating conditions are not known, the test pressure is to be not less than 3,4 bar (3,5 kgf/cm²), see *Pt 5, Ch 14 Machinery Piping Systems*.

7.4 Indicators for movement

7.4.1 Indicators for determining the axial position of rotors relative to their casings, and for showing the longitudinal expansion of casings at the sliding feet, if fitted, are to be provided for main turbines. The latter indicators should be fitted at both sides and be readily visible.

7.5 Wear-down gauges

7.5.1 Main and auxiliary turbines are to be provided with bridge wear-down gauges for testing the alignment of the rotors.

■ Section 8

Cross-references

8.1 The pumping arrangements, including cooling water and lubricating oil systems, are to comply with the requirements of *Pt 5, Ch 13 Ship Piping Systems* and *Pt 5, Ch 14 Machinery Piping Systems*.

For lists of spare gear to be carried, see *Pt 5, Ch 1, 7 Spare gear for machinery installations*.

Section

	Scope
1	General requirements
2	Particulars to be submitted
3	Materials
4	Design and construction
5	Piping systems
6	Starting arrangements
7	Tests
8	Control, alarm and safety systems

■ **Scope**

The requirements of this Chapter are applicable to gas turbines for main propulsion and also, where powers exceed 110 kW (150 shp), to those for essential auxiliary services. The requirements do not apply to exhaust gas turbo-blowers.

Approval will be in respect of the mechanical integrity of the gas turbine (including gas generator and power turbine), intake and exhaust ducting configuration, acoustic enclosure configuration (where appropriate), fuel, lubricating oil and starter systems, control alarm and monitoring systems and other critical support systems.

Type approval of the gas turbine bare engine will be required as part of the approval process for first of type.

Primary exhaust gas emissions abatement plant (where fitted) is to meet the requirements of this Chapter; additionally, it shall meet those of *Pt 5, Ch 24 Emissions Abatement Plant for Combustion Machinery*. Where secondary exhaust gas emissions abatement systems are fitted to gas turbines, they are to meet the requirements of *Pt 5, Ch 24 Emissions Abatement Plant for Combustion Machinery*.

■ *Section 1* **General requirements**

1.1 Application

1.1.1 This Chapter is to be read in conjunction with *Pt 5, Ch 1 General Requirements for the Design and Construction of Machinery General Requirements for the Design and Construction of Machinery*, *Pt 6, Ch 1 Control Engineering Systems Control Engineering Systems*, and *Pt 6, Ch 2 Electrical Engineering Electrical Engineering*.

1.2 Standard reference conditions

1.2.1 Where power, efficiency, heat rate or specific consumption refer to standard conditions (ISO 2314), conditions are to be:

- (a) for the intake air at the compressor flange (compressor intake flare):
 - a total pressure of 101,3 kPa;
 - an ambient temperature of 15°C;
 - a relative humidity of 60 per cent; and
- (b) for the exhaust at the turbine exhaust flange (or recuperator outlet):
 - a static pressure of 101,3 kPa.

1.3 Power ratings

1.3.1 Where the dimensions of any particular component are determined from shaft power, P , in kW, and revolutions per minute, R , the values are those defined in *Pt 5, Ch 1 General Requirements for the Design and Construction of Machinery*.

1.4 Gas turbine type approval

1.4.1 New gas turbine types or developments of existing types are to be type approved in accordance with Lloyd's Register's (hereinafter referred to as 'LR') *Type Approval System Procedure – Test Specification GT04*.

1.4.2 Where a gas turbine type has subsequently proved satisfactory in service with a number of applications, a maximum power uprating of 10 per cent may be considered without a further complete design re-assessment and type test.

1.5 Inclination of vessel

1.5.1 Gas turbines are to operate satisfactorily under the conditions of inclinations as shown in *Table 1.3.2 Inclination of ship*.

■ **Section 2**
Particulars to be submitted

2.1 Plans and information

2.1.1 The following plans are to be submitted for consideration:

- Casings.
- Combustion chambers, intercoolers and heat exchangers.
- Compressor and gas generator rotating components.
- Control engineering systems, *see Pt 6, Ch 1 Control Engineering Systems*.
- Cooling and sealing air arrangements for compressor and gas generator components: Schematic only.
- Cooling water system: Schematic only, where applicable.
- Fuel systems: Schematic only.
- Gas turbine unit acoustic enclosure, if applicable, including ventilation and drainage systems: Schematic only.
- Inlet and exhaust ducting arrangement.
- Lubricating oil systems: Schematic only.
- Nozzles, blades and blade attachments.
- Fuel oil systems: Schematic only.
- Power turbine components.
- Rotors, bearings and couplings.
- Sectional assembly.
- Securing arrangement, including details of resilient mounts, where applicable.
- Starting system: Schematic only.

2.1.2 The following information and calculations, where applicable, are to be submitted:

(a) Operational requirements:

- Proposed field of application and operational limitations.
- Power/speed operational envelope.
- Calculations and information for short-term high power operation.
- Operation and maintenance manuals including the declared lives of critical components and overhaul schedules recommended by the manufacturer.

(b) Calculations of the critical speeds of blade and rotor vibration, giving full details of the basic assumptions, *see also Pt 5, Ch 4, 4.3 Containment 4.3.1*.

(c) Analysis of the effect of rotor blade release together with details of operating experience, *see also Pt 5, Ch 4, 4.3 Containment 4.3.2*.

-
- (d) High temperature characteristics of the materials, including (at working temperatures) the associated creep rate and rupture strength for the designed service life, fatigue strength, corrosion resistance and scaling properties.
- (e) Material requirements:
- Particulars of heat treatment, including stress relief.
 - Material specifications covering the listed components together with details of any surface treatments, non-destructive testing and hydraulic tests.
- (f) The most onerous pressures and temperatures to which each component may be subjected are to be indicated on plans or provided as part of the design specification.
- (g) Calculations of the steady state stresses, including the effect of stress raisers, etc. in the compressor and turbine rotors and blading at the maximum speed and temperature in service. Such calculations are to indicate the designed service life and be accompanied, where possible, by test results substantiating the limiting criteria.
- (h) Details of calculations and tests to establish the service life of other stressed or safety critical components, including bearings, seals, couplings and gearing. Calculations and tests are to take account of all relevant environmental factors including the particular type of service and fuel intended to be used.
- (i) Mounting requirements:
- Securing arrangements, including details of resilient mounts.
 - Calculations concerning the amplitude and frequency of vibration associated with resilient type mountings.
- (j) A Failure Mode and Effects Analysis (FMEA).
- (k) Miscellaneous:
- Design standard of intake filtration for water particulate and corrosive marine salts.
 - Details of compressor washing system.
 - Fuel specification.

2.1.3 Components fabricated by means of welding will be considered for acceptance if constructed by firms whose works are properly equipped to undertake welding of the standards appropriate to the components. Details are to be submitted for consideration.

2.1.4 Before work is commenced, manufacturers are to submit for consideration details of proposed welding procedures and their proposals for routine examination of joints by non-destructive means.

2.1.5 The manufacturer's proposals for testing the gas turbine are to be submitted for consideration and are to include rotor balancing techniques, methods of determining the soundness of pressure casings and heat exchanger tests, see *Pt 5, Ch 4, 1 General requirements*.

■ *Section 3* **Materials**

3.1 Materials for forgings

3.1.1 Details of materials for rotors and discs are to be submitted for approval.

3.2 Material tests and inspection

3.2.1 Components are to be tested in accordance with the relevant requirements of the *Rules for the Manufacture, Testing and Certification of Materials, July 2015* (hereinafter referred to as the Rules for Materials).

3.2.2 For components of novel design, special consideration will be given to the material test and non-destructive testing requirements.

■ Section 4 Design and construction

4.1 General

4.1.1 All parts of compressors, turbines, etc. are to have clearances and fits consistent with adequate provision for the relative thermal expansion of the various components. Provision is to be made to limit the distortion of the casing and rotor under all normal operating conditions.

4.1.2 Gas generator and power turbine bearings are to be so disposed and supported that lubrication is not adversely affected by heat flow from adjacent hot parts. Effective means are to be provided for intercepting oil leakage and preventing oil from reaching high temperature glands and casings.

4.2 Vibration

4.2.1 The design and manufacture of compressor and turbine rotors, rotor discs and rotor blades are to ensure freedom from undue vibration within the full operating speed range. Where critical speeds are found by calculation to occur within the operating speed range, vibration tests may be required in order to verify the calculations, *see also Pt 5, Ch 8 Shaft Vibration and Alignment*.

4.2.2 Vibration monitoring is to form an integral part of the gas turbine safety and control system. The vibration monitoring system is to be capable of detecting the out-of-balance of major parts with means being provided to shutdown the gas turbine, before an over-critical situation occurs, i.e. multiple rotor blade or disc release.

4.3 Containment

4.3.1 Gas turbines and power turbines are to be designed and installed, so far as is practicable, to contain debris in the event of rotor blade release.

4.3.2 In the event of a major component failure, when the turbine casing may not contain the debris; fuel oil, lubricating oil and other potentially hazardous systems or equipment are, where practicable, to be located outside of the plane of high speed rotating parts. This requirement also applies to fire detection and extinction equipment, *see also Pt 5, Ch 4, 5 Piping systems*.

4.3.3 Gas turbine ancillaries containing flammable products are to be segregated or protected from high temperature areas.

4.4 Intake and exhaust ducts

4.4.1 Air intakes are to be designed and located to minimise the possibility of ingestion of harmful objects. Means are also to be provided for detecting and preventing icing up of air intakes.

4.4.2 Suitable intake filtration is to be provided to control the ingestion of water, particulate and corrosive marine salts within the gas turbine manufacturer's specified limits.

4.4.3 Where an air intake enclosure forms the connection between the ship's downtake and the gas turbine installation, a suitable alarm function is to be provided to give warning when an unacceptable air intake pressure loss is reached at the air inlet (bellmouth) of the gas turbine.

4.4.4 Intakes are to be designed such that material cannot become detached due to air flow or corrosion. Fixing bolts and fastenings are to be positively locked so that they cannot work loose.

4.4.5 Multi-engine installations are to have separate intakes and exhausts so arranged as to prevent induced circulation through a stopped gas turbine unit.

4.4.6 The arrangement of the exhaust duct is to be such as to prevent, under normal conditions of ship motion and atmospheric conditions, exhaust gases being drawn into machinery spaces, air conditioning systems and intakes.

4.4.7 Where the exhaust is led overboard near the waterline, means are to be provided to prevent water from being siphoned back into the gas turbine. Where the exhaust is cooled by water spray, the exhaust pipes are to be self-draining overboard. Erosion/corrosion-resistant shut-off flaps or other devices are to be fitted on the hull side shell or pipe end with suitable arrangements made to prevent water flooding the machinery space.

4.5 External influences

4.5.1 Pipes and ducting connected to casings are to be so designed that they apply no excessive loads or moments to the compressors and turbines.

4.5.2 Platform gratings and fittings in way of the supports are to be so arranged that casing expansion is not restricted.

4.5.3 Where the gas turbine seating incorporates a tank structure, any temperature variation of the tank in service is not to adversely affect the gas generator and power turbine alignment.

4.5.4 For machinery fastening arrangements, including resilient mounting, see *Pt 5, Ch 1 General Requirements for the Design and Construction of Machinery*.

4.6 Corrosive deposits

4.6.1 Means are to be provided for periodic removal of salt deposits and atmospheric contaminants from blading and internal surfaces.

4.7 Acoustic enclosures

4.7.1 Acoustic enclosures, where fitted, are to be provided with an access door, adequate internal lighting and one or more observation windows to allow the viewing of critical parts of the gas turbine.

4.7.2 A suitable ventilation system, designed to maintain all components within their safe working temperature under all operating conditions is to be provided.

4.7.3 The ventilation system is to be fitted with shut-off flaps arranged to close automatically upon activation of the enclosure's fire detection and extinguishing system.

4.7.4 Acoustic enclosure fire safety arrangements are to comply with the requirements of *Pt 6, Ch 1 Control Engineering Systems* and the *SOLAS - International Convention for the Safety of Life at Sea* as amended (SOLAS 74), see also *Pt 5, Ch 4, 8.7 Fire detection, alarm and extinguishing systems 8.7.1*.

4.8 Thermal insulation

4.8.1 Where surfaces of the gas generator, power turbine and exhaust volute exceed a temperature of 220°C during operation, these are to be suitably insulated and clad to minimise the risk of fire and prevent damage by heat to adjacent components, see *Pt 5, Ch 4, 5.1 General 5.1.5*.

4.9 Welded construction

4.9.1 Welding is to be carried out in accordance with the requirements of *Ch 13 Requirements for Welded Construction* of the Rules for Materials, using welding procedures and welders that have been qualified in accordance with *Ch 12 Welding Qualifications* of the Rules for Materials.

4.9.2 Stress relief heat treatment is to be applied to all cylinders, rotors and associated components on completion of all welding, see *Pt 5, Ch 17 Requirements for Fusion Welding of Pressure Vessels and Piping*.

4.10 Turning gear

4.10.1 Gas generator turning gear is to be provided to facilitate operating and maintenance regimes as required by the manufacturer.

4.10.2 The turning gear may be hand operated (manual) except where this is not practicable. If electrically driven, the motor is to be continuously rated.

4.10.3 The turning gear is to be fitted with safety interlocks which prevent engine operation when engaged, see *Pt 5, Ch 1, 3.9 Astern power*. Indication of engaged / not engaged is to be provided at all start positions.

4.10.4 The remote control device of power-driven turning gear is to be so designed that power is removed from the turning gear when the operating switch is released.

4.10.5 If permanently attached, means are to be provided to secure the turning gear when disengaged.

■ Section 5
Piping systems**5.1 General**

5.1.1 Gas turbine piping systems are, in general, to comply with the requirements given in *Pt 5, Ch 12 Piping Design Requirements* and *Pt 5, Ch 14 Machinery Piping Systems*, due regard being paid to the particular type of installation. For the burning of compressed natural gas, see the *18 Rules and Regulations for the Construction and Classification of Ships for the Carriage of Liquefied Gases in Bulk, July 2015*.

5.1.2 The materials and/or their surface treatment used for the storage and distribution of fuel oil are to be selected such that they do not introduce contamination or modify the properties of the fuel.

5.1.3 Corrosion resistant materials are to be used in all fuel pipes between the treatment and combustion systems.

5.1.4 Suitable fuel treatment systems, including filtration and centrifuging, are to be provided to control the level of water and particulate contamination within the engine manufacturer's specified limits.

5.1.5 The gas turbine design and construction is to minimise the possibility of a fire fed by fuel or lubricating oil leaks.

5.1.6 In dual-fuel applications, provision is to be made for automatic isolation of both primary and standby fuel supplies to the engine in the event of a fire.

5.2 Fuel oil systems

5.2.1 Fuel oil arrangements are to comply with the requirements of *Pt 5, Ch 14 Machinery Piping Systems*.

5.2.2 All external high pressure fuel oil delivery lines between the pressure fuel pumps and fuel metering valves are to be protected with a jacketed piping system capable of containing fuel from a high pressure line failure to prevent fuel oil or fuel oil mist from reaching a source of ignition on the engine or its surroundings.

5.2.3 Suitable arrangements are to be made for draining any fuel oil leakage from the protection required by *Pt 5, Ch 4, 5.2 Fuel oil systems 5.2.2* and to prevent contamination of the lubricating oil by fuel oil. An alarm is to be provided to indicate that leakage is taking place.

5.2.4 At least two filters are to be fitted in the fuel oil supply lines to the gas turbine and be so arranged that any filter may be cleaned without interrupting the supply of filtered fuel oil to the gas turbine.

5.3 Lubricating oil systems

5.3.1 Lubricating oil arrangements are to comply with the requirements of *Pt 5, Ch 14 Machinery Piping Systems*.

5.3.2 Where the lubricating oil for gas turbines is circulated under pressure, provision is to be made for the efficient filtration of the oil. At least two filters are to be fitted in the lubricating oil supply lines to the gas turbine and be so arranged that any filter may be cleaned without interrupting the supply of filtered lubricating oil to the gas turbine.

5.4 Cooling systems

5.4.1 Cooling water arrangements are to comply with the requirements of *Pt 5, Ch 14 Machinery Piping Systems*, where appropriate.

■ Section 6
Starting arrangements**6.1 General**

6.1.1 Equipment for initial starting of gas turbines is to be provided and arranged such that the necessary initial charge of starting air, hydraulic or electrical power can be developed on board the ship without external aid. If, for this purpose, an

emergency air compressor or electric generator is required, these units are to be power-driven by manually-started oil engines, except in the case of small installations where a hand-operated compressor of approved capacity may be accepted.

6.1.2 Alternatively, other devices of approved type may be accepted as a means of providing the initial start.

6.1.3 Where the integrity of the starting system is susceptible to overspeed conditions, appropriate alarm and/or trip functions are to be provided, *see also Pt 6, Ch 1 Control Engineering Systems*.

6.2 Purging before ignition

6.2.1 Means are to be provided to clear all parts of the gas turbine of the accumulation of fuel oil or for purging gaseous fuel before ignition commences on starting, or recommences after failure to start. The purge is to be of sufficient duration to displace at least three times the volume of the exhaust system.

6.3 Air starting

6.3.1 Where the gas turbine is arranged for air starting, the total air receiver capacity is to be sufficient to provide, without replenishment, not less than six consecutive starts. At least two air receivers of approximately equal capacity are to be provided to satisfy the plant air start requirements. For scantlings and fittings of air receivers, *see Pt 5, Ch 11 Other Pressure Vessels*.

6.3.2 For multi-engine installations, three consecutive starts per engine are required.

6.4 Electric starting

6.4.1 Where the gas turbine is fitted with electric starters powered from batteries, two batteries are to be fitted. Each battery is to be capable of starting the gas turbine and the combined capacity is to be sufficient without recharging to provide the number of starts required by *Pt 5, Ch 4, 6.3 Air starting 6.3.1* or *Pt 5, Ch 4, 6.3 Air starting 6.3.2*.

6.4.2 The requirements for battery installations are given in *Pt 6, Ch 2 Electrical Engineering*.

6.5 Hydraulic starting

6.5.1 Where the gas turbine is arranged for hydraulic starting, the capacity of the power pack is to be sufficient to provide the number of starts of the gas turbine as required by *Pt 5, Ch 4, 6.3 Air starting 6.3.1* or *Pt 5, Ch 4, 6.3 Air starting 6.3.2*.

■ *Section 7* **Tests**

7.1 Dynamic balancing

7.1.1 All compressor and turbine rotors as finished-bladed and complete with all relevant parts such as half-couplings, are to be dynamically balanced in accordance with the manufacturer's specification in a machine of sensitivity appropriate to the size of rotor.

7.2 Hydraulic testing

7.2.1 Where design permits, casings are to be tested to a hydraulic pressure equal to 1,5 times the highest pressure in the casing during normal operation, or 1,5 times the pressure during starting, whichever is the higher. For test purposes, if necessary, the casings may be subdivided with temporary diaphragms for distribution of test pressure. Where the operating temperature exceeds 300°C the test pressure is to be suitably corrected.

7.2.2 Where hydraulic testing is impracticable, 100 per cent non-destructive tests by ultrasonic or radiographic methods are to be carried out on all casing parts with satisfactory results. Where ultrasonic tests have been carried out, the manufacturer is to provide documentary evidence that ultrasonic examination has been carried out by an approved operator and that there were no indications of defects which could be expected to have a prejudicial effect on the operational performance of the gas turbine.

7.2.3 The shell and tube arrangement of intercoolers and heat exchangers are to be tested to 1,5 times their maximum working pressure.

7.3 Overspeed tests

7.3.1 Before installation, it is to be satisfactorily demonstrated that the gas turbine is capable of safe operation for five minutes at 5 per cent above the nominal setting of the overspeed protective device, or 15 per cent above the maximum design speed, whichever is the higher.

7.3.2 Where it is impracticable to overspeed the complete installation, each compressor and turbine rotor completely bladed and with all relevant parts such as half-couplings, are to be overspeed-tested individually at the appropriate speed.

■ *Section 8* **Control, alarm and safety systems**

8.1 General

8.1.1 Control alarm and safety systems are to comply with the requirements of *Pt 6, Ch 1 Control Engineering Systems*.

8.1.2 All gas turbines intended for essential services are to be provided with means of indicating the lubricating oil pressure supply to them. Where such turbines are of more than 37 kW (50 shp), audible and visual alarms are to be fitted to give warning of an appreciable reduction in pressure of the lubricating oil supply. Further, these alarms are to be actuated from the outlet side of any restrictions, such as filters, coolers, etc.

8.2 Overspeed protection and shutdown system

8.2.1 The gas turbine is to be protected against overspeed by the provision of a suitable device(s) capable of shutting-down the gas turbine safely before a dangerous overspeed condition occurs.

8.3 Power turbine inlet over-temperature control

8.3.1 The power turbine is to be protected against over-temperature by the provision of a suitable device(s) capable of controlling the temperature within acceptable limits or shutting-down the gas turbine safely to prevent damage.

8.4 Flameout

8.4.1 Indication is to be provided for identifying poor combustion from each combustion chamber, flame-out and failure to ignite conditions, *see also Pt 5, Ch 4, 6.2 Purging before ignition 6.2.1*.

8.5 Lubricating oil system

8.5.1 Means are to be provided to accurately determine the pressure and temperature of the lubricating oil supply to the various parts of the gas generator and power turbine, and scavenge oil and return systems to ensure safe operation.

8.5.2 Means are to be provided to ensure that the temperature of the lubrication oil supply is automatically controlled to maintain steady-state conditions throughout the normal operating range of the gas turbine.

8.5.3 Where the oil supply to the power turbine is fed from a separate supply system, similar arrangements to those detailed above are to be provided.

8.6 Hand trip arrangement

8.6.1 Means are to be provided, at both the local and remote control/operating positions, to manually initiate the shutdown of the gas turbine in an emergency.

8.7 Fire detection, alarm and extinguishing systems

8.7.1 The gas turbine installation is to be provided with a fire detection, alarm and extinguishing system. The requirements of *Pt 6, Ch 1 Control Engineering Systems* and the *SOLAS - International Convention for the Safety of Life at Sea* as amended (SOLAS 74) are to be complied with.

8.8 Unattended machinery

8.8.1 Where gas turbines are fitted with automatic or remote controls so that under normal operating conditions they do not require any manual intervention by the operators, they are to be provided with the alarms and safety arrangements required by *Pt 5, Ch 4, 8.8 Unattended machinery* to *Pt 5, Ch 4, 8.9 Gas turbine machinery* as appropriate. Alternative arrangements which provide equivalent safeguards will be considered.

8.8.2 Where machinery is arranged to start automatically or from a remote control station, interlocks are to be provided to prevent start-up under conditions which could hazard the machinery.

8.8.3 Where machinery specified in this Section is required to be provided with a standby pump, the standby pump is to start automatically if the discharge pressure from the working pumps falls below a predetermined value.

8.8.4 Where a first stage alarm together with a second stage alarm and automatic shutdown of machinery are required in the relevant Tables of this Section, the sensors and circuits utilised for the second stage alarm and automatic shutdown are to be independent of those required for the first stage alarm. LR will consider alternative arrangements which provide an equivalent level of safety.

8.9 Gas turbine machinery

8.9.1 Alarms and safeguards are indicated in *Pt 5, Ch 4, 8.9 Gas turbine machinery 8.9.2* to *Pt 5, Ch 4, 8.9 Gas turbine machinery 8.9.4* and *Table 4.8.1 Gas turbine machinery: Alarms and safeguards*.

Table 4.8.1 Gas turbine machinery: Alarms and safeguards

Item	Alarm	Note
Overspeed	High	Automatic shutdown <i>see also Pt 5, Ch 4, 8.2 Overspeed protection and shutdown system</i>
Power turbine inlet temperature	1st stage high	Automatic power reduction
	2nd stage high	Automatic shutdown <i>see also Pt 5, Ch 4, 8.3 Power turbine inlet over-temperature control</i>
Flame failure	Failure	Automatic shutdown, <i>see also Pt 5, Ch 4, 8.4 Flameout</i>
Failure to ignite	Failure	Automatic shutdown, <i>see also Pt 5, Ch 4, 8.4 Flameout</i>
Lubricating oil pressure	1st stage low	—
	2nd stage low	Automatic shutdown, <i>see also Pt 5, Ch 4, 8.5 Lubricating oil system</i>
Lubricating oil temperature	High	<i>See also Pt 5, Ch 4, 8.5 Lubricating oil system</i>
Lubricating oil filter differential pressure	High	—
Scavenge oil temperature	High	—
Scavenge oil pressure	Low	Automatic shutdown
Bearing temperature	High	—
Turbine vibration	1st stage high	—
	2nd stage high	Automatic shutdown, <i>see also Pt 5, Ch 4, 4.2 Vibration</i>
Fuel oil supply pressure	Low	—
Fuel oil supply temperature	High	—
Fuel oil leakage	High	<i>See also Pt 5, Ch 4, 5.2 Fuel oil systems</i>
Automatic starting	Failure	Automatic shutdown
Control system	Failure	Automatic shutdown
Air intake pressure	Low	<i>See also Pt 5, Ch 4, 4.4 Intake and exhaust ducts 4.4.4</i>
Feed water or water/thermal fluid forced circulation flow (if fitted)	Low	<i>See Pt 5, Ch 14, 6.2 Feed and circulation pumps 6.2.7 and Note 4</i>
Uptake temperature	High	To monitor for soot fires. <i>See Notes 4 and 5</i>
<p>Note 1. For two-stage alarms, <i>see also Pt 5, Ch 4, 8.8 Unattended machinery 8.8.4.</i></p> <p>Note 2. For requirements on purging before ignition, <i>see Pt 5, Ch 4, 6.2 Purging before ignition 6.2.1.</i></p> <p>Note 3. Where a requirement for disabling the automatic protection and safety system devices for machinery and engineering systems has been defined by the Owner, the consequences of using the disabling arrangements are to be established and included in the operations procedures and orders provided on board ship. Details of any disabling arrangements are to be submitted to LR for consideration in each instance.</p> <p>Note 4. Alarm is required only when suitable for operation on residual fuel grades and an exhaust gas economiser/boiler/thermal oil heater is fitted.</p> <p>Note 5. Alternatively, details of an appropriate fire detection system are to be submitted for consideration.</p>		

8.9.2 The following turbine services are to be fitted with automatic temperature controls so as to maintain steady state conditions throughout the normal operating range of the turbine:

- (a) Lubricating oil supply.
- (b) Fuel oil supply, *see also Pt 5, Ch 4, 8.9 Gas turbine machinery 8.9.3.*

(c) Exhaust gas.

8.9.3 The fuel oil supply may be fitted with an automatic control for viscosity instead of the temperature control required by *Pt 5, Ch 4, 8.9 Gas turbine machinery 8.9.2*.

8.9.4 A means of manually shutting off the fuel in an emergency is to be provided at the manoeuvring station.

*Section***Scope**

- 1 **Plans and particulars**
- 2 **Materials**
- 3 **Design**
- 4 **Construction**
- 5 **Tests**
- 6 **Control and monitoring**
- 7 **Cross-reference**

**Scope**

The requirements of this Chapter, except where otherwise stated are applicable to oil engine gearing for main propulsion purposes and for oil engine gearing for driving auxiliary machinery which is essential for the safety of the ship or for safety of persons on board where the transmitted powers exceed 220 kW (300 shp) for propulsion drives, and 110 kW (150 shp) for auxiliary drives. Alternatively calculations using the methods defined in ISO 6336 – *Calculation of load capacity of spur and helical gears*, will be considered. In any mesh, the terms pinion and wheel refer to the smaller and larger gear respectively. For turbine gearing the loading factors K_A , $K_{F\alpha}$, $K_{F\beta}$, $K_{H\alpha}$, $K_{H\beta}$ and K_γ will be considered. Bevel gears will be specially considered on the basis of a conversion to equivalent helical gears. For torsional vibration requirements, see Pt 5, Ch 8, 2.3 *Scope of calculations*.

*Section 1***Plans and particulars****1.1 Gearing plans**

1.1.1 Particulars of the gearing are to be submitted with the plans for all propulsion gears and for auxiliary gears where the transmitted power exceeds 110 kW (150 shp), as follows:

- (a) Plans and information demonstrating conformance with the applicable Rules and Standards as stated in scope.
- (b) Shaft power and revolution for each pinion.
- (c) Number of teeth in each gear.
- (d) Reference diameters.
- (e) Helix angles at reference diameters.
- (f) Normal pitches of teeth at reference diameters.
- (g) Tip diameters.
- (h) Root diameters.
- (i) Face widths and gaps, where applicable.
- (j) Pressure angles of teeth (normal or transverse) at reference diameters.
- (k) Accuracy grade Q in accordance with ISO 1328 or an equivalent Standard.
- (l) Surface texture of tooth flanks and roots.
- (m) Minimum backlash.
- (n) Centre distance.
- (o) Basic rack tooth form.
- (p) Protuberance and final machining allowance.

- (q) Details of post hobbing processes, if any.
- (r) Details of tooth flank corrections, if adopted.
- (s) Case depth for surface-hardened teeth.
- (t) Shrinkage allowance for shrunk-on rims and hubs.
- (u) Type of coupling proposed for oil engine applications.

1.2 Material specifications

1.2.1 Specifications for materials of pinions, pinion sleeves, wheel rims, gear wheels, and quill shafts, giving chemical composition, heat treatment and mechanical properties, are to be submitted for approval with the plans of gearing.

1.2.2 Where the teeth of a pinion or gear wheel are to be surface hardened, i.e. carburised, nitrided, tufftrided or induction-hardened, the proposed specification and details of the procedure are to be submitted for approval.

■ **Section 2 Materials**

2.1 Material properties

2.1.1 In the selection of materials for pinions and wheels, consideration is to be given to their compatibility in operation. Except in the case of low reduction ratios, for gears of through-hardened steels, provision is also to be made for a hardness differential between pinion teeth and wheel teeth. For this purpose, the specified minimum tensile strength of the wheel rim material is not to be more than 85 per cent of that of the pinion.

2.1.2 Subject to *Pt 5, Ch 5, 2.1 Material properties 2.1.1*, the specified minimum tensile strength is to be selected within the following limits:

Pinion and pinion sleeves	550 to 1050 N/mm ² (56 to 107 kgf/mm ²)
Gear wheels and rims	400 to 850 N/mm ² (41 to 87 kgf/mm ²)

A tensile strength range is also to be specified and is not to exceed 120 N/mm² (12 kgf/mm²) when the specified minimum tensile strength is 600 N/mm² (61 kgf/mm²) or less. For higher strength steels, the range is not to exceed 150 N/mm² (15 kgf/mm²).

2.1.3 Unless otherwise agreed, the full specified minimum tensile strength of the core is to be 800 N/mm² (82 kgf/mm²) for induction-hardened or nitrided gearing and 750 N/mm² (76 kgf/mm²) for carburised gearing.

2.1.4 For nitrided gearing, the full depth of the hardened zone is to be not less than 0,5 mm and the hardness is to be not less than 500 HV for a depth of 0,25 mm.

2.2 Non-destructive tests

2.2.1 An ultrasonic examination is to be carried out on all gear blanks where the finished diameter of the surfaces, where teeth will be cut, is in excess of 200 mm.

2.2.2 Magnetic particle or liquid penetrant examination is to be carried out on all surface-hardened teeth. This examination may also be requested on the finished machined teeth of through-hardened gears.

■ **Section 3 Design**

3.1 Symbols

3.1.1 For the purposes of this Chapter the following symbols apply:

a = centre distance, in mm

b = face width, in mm

d = reference diameter, in mm

d_a = tip diameter, in mm

d_{an} = virtual tip diameter, in mm

d_b = base diameter, in mm

d_{bn} = virtual base diameter, in mm

d_{en} = virtual diameter to the highest point of single tooth pair contact, in mm

d_f = root diameter, in mm

d_{fn} = virtual root diameter, in mm

d_n = virtual reference diameter, in mm

d_s = shrink diameter, in mm

d_w = pitch circle diameter, in mm

f_{ma} = tooth flank misalignment due to manufacturing errors, in μm

f_{pb} = maximum base pitch deviation of wheel, in μm

f_{Sh} = tooth flank misalignment due to wheel and pinion deflections, in μm

f_{Sho} = intermediary factor for the determination of f_{Sh}

g_a = length of line of action for external gears, in mm:

$$= 0,5 \sqrt{(d_{a1}^2 - d_{b1}^2)} + 0,5 \sqrt{(d_{a2}^2 - d_{b2}^2)} - a \sin \alpha_{tw}$$

= for internal gears:

$$= 0,5 \sqrt{(d_{a1}^2 - d_{b1}^2)} - 0,5 \sqrt{(d_{a2}^2 - d_{b2}^2)} + a \sin \alpha_{tw}$$

h = total depth of tooth, in mm

h_{ao} = basic rack addendum of tool, in mm

h_F = bending moment arm for root stress, in mm

h_W = sum of actual tooth addenda of pinion and wheel, in mm

m_n = normal module, in mm

n = rev/min of pinion

q = machining allowances, in mm

q_s = notch parameter

q' = intermediary factor for the determination of C_γ

u = gear ratio = $\frac{\text{Number of teeth in wheel}}{\text{Number of teeth in pinion}} \geq 1$

v = linear speed at pitch circle, in m/s

x = addendum modification coefficient

y_α = running in allowance, in μm

y_β = running in allowance, in μm

z = number of teeth

z_n = virtual number of teeth

$$= \frac{z}{\cos^2 \beta_b \cos \beta}$$

C_γ = tooth mesh stiffness (mean total mesh stiffness per unit face width), in N/mm μm

F_t = nominal tangential tooth load, in N

$$= \frac{p}{nd} 19,098 \times 10^6$$

F_β = total tooth alignment deviation (maximum value specified), in μm

$F_{\beta x}$ = actual longitudinal tooth flank deviation before running in, in μm

$F_{\beta y}$ = actual longitudinal tooth flank deviation after running in, in μm

HV = Vickers hardness number

K_A = application factor

$K_{F\alpha}$ = transverse load distribution factor

$K_{F\beta}$ = longitudinal load distribution factor

$K_{H\alpha}$ = transverse load distribution factor

$K_{H\beta}$ = longitudinal load distribution factor

K_v = dynamic factor

$K_{v\alpha}$ = dynamic factor for spur gears

$K_{v\beta}$ = dynamic factor for helical gears

K_γ = load sharing factor

P = transmitted power, in kW

P_r = radial pressure at shrinkage surface, in N/mm²

P_{r0} = protuberance of tool, in mm

- R_a = surface roughness – arithmetical mean deviation (C.L.A.) as determined by an instrument having a minimum wavelength cut-off of 0,8 mm and for a sampling length of 2,5 mm, in μm
- S_{pr} = residual undercut left by protuberance in mm
- $S_{F\min}$ = minimum factor of safety for bending stress
- S_{Fn} = tooth root chord in the critical section, in mm
- $S_{H\min}$ = minimum factor of safety for Hertzian contact stress
- S_R = rim thickness of gears, in mm
- Y_B = rim thickness factor
- Y_D = design factor
- Y_{DT} = deep tooth factor
- Y_F = tooth form factor
- $Y_{R\text{rel}T}$ = relative surface finish factor
- Y_S = stress correction factor
- Y_{ST} = stress correction factor (relevant to the dimensions of the standard reference test gears)
- Y_x = size factor
- Y_{β} = helix angle factor
- $Y_{\delta\text{rel}T}$ = relative notch sensitivity factor
- Z_E = material elasticity factor
- Z_H = zone factor
- Z_R = surface finish factor
- Z_V = velocity factor
- Z_X = size factor
- Z_{β} = helix angle factor
- Z_{ϵ} = contact ratio factor
- α_{en} = pressure angle at the highest point of single tooth contact, in degrees
- α_n = normal pressure angle at reference diameter, in degrees
- α_t = transverse pressure angle at reference diameter, in degrees
- α_{tw} = transverse pressure angle at pitch circle diameter, in degrees
- α_{Fen} = angle for application of load at the highest point of single tooth contact, in degrees
- β = helix angle at reference diameter, in degrees

β_b = helix angle at base diameter, in degrees

γ = intermediary factor for the determination of f_{sh}

ϵ_α = transverse contact ratio

$$= \frac{g_\alpha \cos \beta}{\pi m_n \cos \alpha_t}$$

$\epsilon_{\alpha n}$ = virtual transverse contact ratio

ϵ_β = overlap ratio

$$= \frac{b \sin \beta}{\pi m_n}$$

ϵ_γ = total contact ratio

ρ_{a0} = tip radius of tool, in mm

ρ_c = relative radius of curvature at pitch point, in mm

$$= \frac{a \sin \alpha_{tw} u}{\cos \beta_b (1 + u)^2}$$

ρ_F = tooth root fillet radius at the contact of the 30° tangent, in mm

σ_y = yield or 0,2 per cent proof stress, in N/mm²

σ_B = ultimate tensile strength, in N/mm²

σ_F = bending stress at tooth root, in N/mm²

$\sigma_{F \text{ lim}}$ = endurance limit for bending stress in N/mm²

σ_{FP} = allowable bending stress at the tooth root, in N/mm²

σ_H = Hertzian contact stress at the pitch circle, in N/mm²

$\sigma_{H \text{ lim}}$ = endurance limit for Hertzian contact stress, in N/mm²

σ_{HP} = allowable Hertzian contact stress, in N/mm²

Subscript:

$_1$ = pinion

$_2$ = wheel

$_0$ = tool.

3.2 Tooth form

3.2.1 The tooth profile in the transverse section is to be of involute shape, and the roots of the teeth are to be formed with smooth fillets of radii not less than $0,25m_n$.

3.2.2 All sharp edges left on the tips and ends of pinion and wheel teeth after hobbing and finishing are to be removed.

3.3 Tooth loading factors

3.3.1 For values of application factor, K_A see *Table 5.3.1 Values of K_A* .

Table 5.3.1 Values of K_A

Main and auxiliary gears	K_A
Main propulsion oil engine reduction gears:	
Hydraulic coupling or equivalent on input	1,10
High elastic coupling on input	1,30
Other coupling	1,50
Auxiliary gears:	
Electric and diesel engine drives with hydraulic coupling or equivalent on input	1,00
Diesel engine drives with high elastic coupling on input	1,20
Diesel engine drives with other couplings	1,40

3.3.2 Load sharing factor, K_γ . When a gear drives two or more mating gears where the total transmitted load is not evenly distributed between the individual meshes, a factor, K_γ , is to be applied. K_γ is defined as the ratio between the maximum load through an actual path and the evenly shared load. This is to be determined by measurements. Where a value cannot be determined in such a way, the values in *Table 5.3.2 Values of K_γ* may be considered:

Table 5.3.2 Values of K_γ

	K_γ
Spur Gear	1,0
Epicyclic Gears	
Up to 3 planetary gears	1,0
4 planetary gears	1,2
5 planetary gears	1,3
6 planetary gears and over	1,4

3.3.3 Dynamic factor, K_v , is to be calculated as follows when all the following conditions are satisfied:

$$\frac{vz_1}{100} \sqrt{\frac{u^2}{1+u^2}} < 10\text{m/s}$$

- spur gears ($\beta = 0^\circ$) and helical gears with $\beta \leq 30^\circ$
- pinion with relatively low number of teeth, $z_1 < 50$
- solid disc wheels or heavy steel gear rim

Or this method may also be applied to all types of gears if:

$$\frac{vz_1}{100} \sqrt{\frac{u^2}{1+u^2}} < 3\text{m/s}$$

And to helical gears where $\beta > 30^\circ$

(a) For spur gears and for helical gears with $\epsilon_\beta \geq 1$:

$$K_v = 1 + \left(\frac{K_1}{\frac{F_t}{K_A b}} + K_2 \right) \frac{vz_1}{100} K_3 \sqrt{\frac{u^2}{1+u^2}}$$

Where $K_A F_t/b$ is less than 100 N/mm, the value 100 N/mm is to be used.

Numerical values for the factor K_1 are to be as specified in the *Table 5.3.3 Values of K_1* .

Table 5.3.3 Values of K_1

	K_1 ISO accuracy Grade					
	3	4	5	6	7	8
Spur Gears	2,1	3,9	7,5	14,9	26,8	39,1
Helical Gears	1,9	3,5	6,7	13,3	23,9	34,8

For all accuracy grades the factor K_2 is to be in accordance with the following:

- for spur gears $K_2 = 0,0193$
- for helical gears $K_2 = 0,0087$

Factor K_3 is to be in accordance with the following:

$$\text{If } \frac{vz_1}{100} \sqrt{\frac{u^2}{1+u^2}} \leq 0,2 \text{ then } K_3 = 2,071 - 0,357 \frac{vz_1}{100} \sqrt{\frac{u^2}{1+u^2}}$$

$$\text{If } \frac{vz_1}{100} \sqrt{\frac{u^2}{1+u^2}} > 0,2 \text{ then } K_3 = 2,071 - 0,357 \frac{vz_1}{100} \sqrt{\frac{u^2}{1+u^2}}$$

- (b) For helical gears with overlap ratio $\epsilon_\beta < 1$, the value K_v is to be determined by linear interpolation between values determined for spur gears ($K_{v\alpha}$) and helical gears ($K_{v\beta}$) in accordance with:

$$K_v = K_{v\alpha} - \epsilon_\beta (K_{v\alpha} - K_{v\beta})$$

$K_{v\alpha}$ is the K_v value for spur gears, in accordance with (a)

$K_{v\beta}$ is the K_v value for helical gears, in accordance with (b)

3.3.4 Longitudinal load distribution factors, $K_{H\beta}$ and $K_{F\beta}$:

$$K_{H\beta} = 1 + \frac{b F_{\beta y} C_\gamma}{2 F_t K_A K_\gamma K_v}$$

Calculated values of $K_{H\beta} > 2$ are to be reduced by improved accuracy and helix correction as necessary:

where

$$F_{\beta y} = F_{\beta x} - y_\beta \text{ and}$$

$$F_{\beta x} = 1,33 f_{Sh} + f_{ma}$$

$$f_{ma} = 2/3 F_\beta \text{ at the design stage, or}$$

$$f_{ma} = 1/3 F_\beta \text{ where helix correction has been applied}$$

$$f_{Sh} = \frac{F_t K_A K_\gamma K_v}{f_{Sho} b} \text{ where}$$

$$f_{Sho} = 23\gamma 10^{-3} \mu\text{m mm/N for gears without helix correction and without end relief, or}$$

$$= 16\gamma 10^{-3} \mu\text{m mm/N for gears without helix correction but with end relief, where}$$

where

$$\begin{aligned} \gamma &= \left(\frac{b}{d_1}\right)^2 \text{ for single helical and spur gears} \\ &= 3 \left(\frac{b}{2d_1}\right)^2 \text{ for double helical gears} \end{aligned}$$

The following minimum values are applicable, these also being the values where helix correction has been applied:

$$\begin{aligned} f_{Sho} &= 10 \times 10^{-3} \mu\text{m mm/N for helical gears, or} \\ &= 5 \times 10^{-3} \mu\text{m mm/N for spur gears} \end{aligned}$$

For through-hardened steels and surface hardened steels running on through-hardened steels:

$$\begin{aligned} y_{\beta} &= \frac{320}{\sigma_{H \text{ lim}}} F_{\beta x} \text{ when} \\ y_{\beta} &\leq \frac{12800}{\sigma_{H \text{ lim}}} \mu\text{m, and} \end{aligned}$$

For surface hardened steels, when

$$\begin{aligned} y_{\beta} &= 0,15 F_{\beta x} \\ y_{\beta} &\leq 6 \mu\text{m} \\ K_{F\beta} &= K_{H\beta}^n \end{aligned}$$

where

$$n = \frac{\left(\frac{b}{h}\right)^2}{1 + \frac{b}{h} + \left(\frac{b}{h}\right)^2}$$

Note 1. $\frac{b}{h}$ is to be taken as the smaller of $\frac{b_1}{h_1}$ or $\frac{b_2}{h_2}$

Note 2. For double helical gears $\frac{b}{2}$ is to be substituted for b in the equation for n .

3.3.5 Transverse load distribution factors, $K_{H\alpha}$ and $K_{F\alpha}$

(a) Values $K_{H\alpha}$ and $K_{F\alpha}$ for gears with total contact ratio $\epsilon_{\gamma} \leq 2$

$$K_{H\alpha} = K_{F\alpha} = \frac{\epsilon_{\gamma}}{2} \left\{ 0,9 + \frac{0,4 C_{\gamma} (f_{pb} - y_{\alpha}) b}{F_t K_A K_{\gamma} K_v K_{H\beta}} \right\}$$

(b) Values $K_{H\alpha}$ and $K_{F\alpha}$ for gears with total contact ratio $\epsilon_{\gamma} > 2$

$$K_{H\alpha} = K_{F\alpha} = 0,9 + 0,4 \sqrt{\frac{2(\epsilon_{\gamma} - 1)}{\epsilon_{\gamma}}} \left\{ \frac{C_{\gamma} (f_{pb} - y_{\alpha}) b}{F_t K_A K_{\gamma} K_v K_{H\beta}} \right\}$$

Limiting conditions for $K_{H\alpha}$

If $K_{H\alpha} > \frac{\epsilon_{\gamma}}{\epsilon_a Z^2}$ when calculated in accordance with (a) or (b), then $K_{H\alpha} = \frac{\epsilon_{\gamma}}{\epsilon_a Z^2}$

If $K_{H\alpha} < 1$ when calculated in accordance with (a) or (b), then $K_{H\alpha} = 1$

Limiting conditions for $K_{F\alpha}$:

If $K_{F\alpha} > \frac{\epsilon_{\gamma}}{0,25 \epsilon_{\alpha} + 0,75}$ when calculated in accordance with (a) or (b), then $K_{F\alpha} = \frac{\epsilon_{\gamma}}{0,25 \epsilon_{\alpha} + 0,75}$

If $K_{F\alpha} < 1$ when calculated in accordance with (a) or (b), then $K_{F\alpha} = 1$

where

When tip relief is applied f_{pb} is to be half of the maximum specified value:

$$y_{\alpha} = \frac{160}{\sigma_{H \text{ lim}}} f_{pb} \text{ for through-hardened steels, when}$$

$$y_{\alpha} \leq \frac{6400}{\sigma_{H \text{ lim}}} \mu\text{m and}$$

$$y_{\alpha} = 0,075 f_{pb} \text{ for surface hardened steels, when}$$

$$y_{\alpha} \leq 3 \mu\text{m}$$

When pinion and wheel are manufactured from different materials:

$$y_{\alpha} = \frac{y_{\alpha 1} + y_{\alpha 2}}{2}$$

3.3.6 Tooth mesh stiffness, C_{γ} :

$$C_{\gamma} = \frac{0,8}{q'} \cos \beta (0,75 \epsilon_a + 0,25) \text{N/mm} \mu\text{m}$$

where

$$q' = 0,04723 + \frac{0,1551}{z_{n1}} + \frac{0,25791}{z_{n2}} - 0,00635x_1 - \frac{0,11654x_1}{z_{n1}} - 0,00193x_2 - \frac{0,24188x_2}{z_{n2}} + 0,00529x_1^2 + 0,00182x_2^2$$

For internal gears $z_{n2} = \infty$

Other calculations methods for C_{γ} will be specially considered.

3.4 Tooth loading for surface stress

3.4.1 The Hertzian contact stress, σ_H , at the pitch circle is not to exceed the allowable Hertzian contact stress, σ_{HP} .

$$\sigma_H = Z_H Z_E Z_{\epsilon} Z_{\beta} \sqrt{\frac{F_t(u+1)}{d_1 b u}} K_A K_{\gamma} K_v K_H K_{\beta} K_{H\alpha} \text{ and}$$

$$\sigma_{HP} = \frac{\sigma_{H \text{ lim}} Z_R Z_V Z_X}{S_{H \text{ min}}} \text{ for the pinion / wheel combination}$$

where

$$Z_H = \sqrt{\frac{2 \cos \beta_b}{\cos^2 \alpha_t \tan \alpha_{tw}}}$$

$$Z_E = 189,8 \text{ for steel}$$

Z_{ϵ} , contact ratio factor is to be calculated as follows:

for helical gears:

$$Z_{\epsilon} = \sqrt{\frac{4 - \epsilon_{\alpha} (1 - \epsilon_{\beta})}{3} + \frac{\epsilon_{\beta}}{\epsilon_{\alpha}}} \text{ for } 3 \beta < 1 \text{ and}$$

$$Z_{\epsilon} = \sqrt{\frac{1}{\epsilon_{\alpha}}} \text{ for } 3 \beta \geq 1$$

for spur gears:

$$Z_{\epsilon} = \sqrt{\frac{4 - \epsilon}{3} \alpha}$$

$$Z_{\beta} = \sqrt{\frac{1}{\cos \beta}}$$

$$Z_R = \left(\frac{3}{R_{Z10}} \right)^{C_{ZR}}$$

where

$$R_Z = \frac{R_{z1} + R_{z2}}{2}$$

The peak-to-valley roughness determined for the pinion R_{z1} and for the wheel R_{z2} are mean values for the peak-to-valley roughness R_z measured on several tooth flanks.

$$R_{z10} = R_Z \sqrt[3]{\frac{10}{\rho_{red}}}$$

relative radius of curvature:

$$\rho_{red} = \frac{\rho_1 \cdot \rho_2}{\rho_1 + \rho_2}$$

where:

$$\rho_{1,2} = 0,5 \cdot d_{b1,2} \cdot \tan \alpha_{tw}$$

For internal gears, d_b has a negative sign.

If R_a , the surface roughness of the tooth flanks is given then the following approximation may be applied:

$$R_a = \frac{R_z}{6}$$

C_{ZR} is to be taken from *Table 5.3.4 Values of C_{ZR}* .

$$Z_v = 0,88 + 0,23 \left(0,8 + \frac{32}{v} \right)^{-0,5}$$

For values of Z_x , see *Table 5.3.5 Values of Z_x*

σ_{Hlim} , see *Table 5.3.6 Values of endurance limit for Hertzian contact stress, σ_{Hlim}*

S_{Hmin} , see *Table 5.3.7 Factors of safety*.

Table 5.3.4 Values of C_{ZR}

σ_{Hlim}	C_{ZR}
$\sigma_{Hlim} < 850 \text{ N/mm}^2$	0,1500
$850 \text{ N/mm}^2 \leq \sigma_{Hlim} \leq 1200 \text{ N/mm}^2$	$= 0,32 - 0,0002 \sigma_{Hlim}$
$\sigma_{Hlim} > 1200 \text{ N/mm}^2$	0,080

Table 5.3.5 Values of Z_x

Pinion heat treatment	Z_x	
Carburised and induction-hardened	$m_n \leq 10$	1,00
	$10 < m_n < 30$	$1,05 - 0,005 m_n$
	$30 \leq m_n$	0,9

Nitrided	$m_n < 7,5$	1,00
	$7,5 < m_n < 30$	$1,08 - 0,011m_n$
	$30 \leq m_n$	0,75
Through-hardened	All modules	1,00

Table 5.3.6 Values of endurance limit for Hertzian contact stress, $\sigma_{H \text{ lim}}$

Pinion	Heat treatment		$\sigma_{H \text{ lim}}$ N/mm ²
	Pinion	Wheel	
Through-hardened	Through-hardened		$0,46\sigma_{B2} + 255$
Surface-hardened	Through-hardened		$0,42\sigma_{B2} + 415$
Carburised, nitrided or induction-hardened	Soft bath nitrided(Tufftrided)		1000
Carburised, nitrided or induction-hardened	Induction-hardened		$0,88 \text{ HV}_2 + 675$
Carburised or nitrided	Nitrided		1300
Carburised	Carburised		1500

Table 5.3.7 Factors of safety

	$S_{H \text{ min}}$	$S_{F \text{ min}}$
Main propulsion gears	1,4	1,8
Auxiliary gears	1,15	1,40

3.5 Tooth loading for bending stress

3.5.1 The bending stress at the tooth root, σ_F is not to exceed the allowable tooth root bending stress σ_{FP}

$$\sigma_F = \frac{F_t}{b m_n} Y_F Y_S Y_\beta Y_B Y_{DT} K_A K_\gamma K_v K_F \alpha K_{F\beta} \text{ N/mm}^2$$

$$\sigma_{FP} = \frac{\sigma_{F \text{ lim}} Y_{ST} Y_\delta \text{ rel } T^Y_R \text{ rel } T^Y_x}{S_{F \text{ min}} Y_D} \text{ N/mm}^2$$

For values of $S_{F \text{ min}}$, see Table 5.3.7 Factors of safety

$\sigma_{F \text{ lim}}$, see Table 5.3.8 Values of endurance limit for bending stress, $\sigma_{F \text{ lim}}$

Stress correction factor $Y_{ST} = 2$.

3.5.2 Tooth form factor, Y_F :

$$Y_F = \frac{6 \frac{h_F}{m_n} \cos \alpha_{F \text{ en}}}{\left(\frac{S_{Fn}}{m_n}\right)^2 \cos \alpha_n}$$

where h_F , $\alpha_{F \text{ en}}$ and S_{Fn} are shown in Figure 5.3.1 Normal tooth section.

$$\frac{S_{Fn}}{m_n} = z_n \sin\left(\frac{\pi}{3} - v\right) + \sqrt{3} \left(\frac{G}{\cos v} - \frac{\rho_{ao}}{m_n}\right)$$

where

$$v = \frac{2G}{z_n} \tan v - H$$

$$G = \frac{\rho_{ao}}{m_n} - \frac{h_{ao}}{m_n} + x$$

$$H = \frac{2}{z_n} \left(\frac{\pi}{2} - \frac{E}{m_n} \right) - \frac{\pi}{3}$$

$$E = \frac{\pi}{4} m_n - h_{ao} \tan \alpha_n + \frac{S_{pr}}{\cos \alpha_n} - (1 - \sin \alpha_n) \frac{\rho_{ao}}{\cos \alpha_n}$$

$E, h_{ao}, \alpha_n, S_{pr}$ and ρ_{ao} are shown in Figure 5.3.2 External tooth forms

$$\frac{\rho_F}{m_n} = \frac{\rho_{ao}}{m_n} + \frac{2G^2}{\cos v (z_n \cos^2 v - 2G)}$$

$$d_{en} = \frac{2z}{|z|} \left[\left[\sqrt{\left(\frac{d_{an}}{2} \right)^2 - \left(\frac{d_{bn}}{2} \right)^2} - \frac{\pi d \cos \beta \cos \alpha_n (\epsilon_{an} - 1)}{|z|} \right]^2 + \left(\frac{d_{bn}}{2} \right)^2 \right]^{\frac{1}{2}}$$

where

$$d_{an} = d_n + d_a - d$$

$$d_n = \frac{d}{\cos^2 \beta_b}$$

$$d_{bn} = d_n \cos \alpha_n$$

$$\epsilon_{an} = \frac{\epsilon_a}{\cos^2 \beta_b}$$

$$\gamma_e = \frac{\frac{\pi}{2} + 2x \tan \alpha_n}{z_n} + \text{inv. } \alpha_n - \text{inv. } \alpha_{en}$$

where

$$\alpha_{en} = \arccos \frac{d_{bn}}{d_{en}}$$

$$= \frac{h_F}{m_n} = \frac{1}{2} \left[\left(\cos \gamma_e - \sin \gamma_e \tan \alpha_{Fen} \right) \frac{d_{en}}{m_n} - z_n \cos \left(\frac{\pi}{3} - v \right) - \frac{G}{\cos v} + \frac{\rho_{ao}}{m_n} \right]$$

where

$$\alpha_{Fen} = \alpha_{en} - \gamma_e.$$

Table 5.3.8 Values of endurance limit for bending stress, $\sigma_{F \text{ lim}}$

Heat treatment	$\sigma_{F \text{ lim}}$ N/mm ²
Through-hardened carbon steel	$0,09\sigma_B + 150$
Through-hardened alloy steel	$0,1\sigma_B + 185$
Soft bath nitrided (Tufftrided)	330
Induction hardened	$0,35 \text{ HV} + 125$

Gas nitrided	390
Carburised A	450
Carburised B	410
Note 1. A is applicable for Cr Ni Mo carburising steels.	
Note 2. B is applicable for other carburising steels.	

3.5.3 For internal tooth forms the form factor is calculated, as an approximation, for a substitute gear rack with the form of the basic rack in the normal section, but having the same tooth depth as the internal gear:

$$\frac{S_{Fn2}}{m_n} = 2 \left[\frac{\pi}{4} + \tan \alpha \left(\frac{h_{ao2} - \rho_{ao2}}{m_n} \right) + \left(\frac{r_{ao2} - S_{pr}}{m_n \cos \alpha_n} \right) - \left| \left[\frac{\rho_{ao2}}{m_n} \cos \frac{\pi}{6} \right] \right| \right]$$

and

$$\frac{h_{F2}}{m_n} = \frac{d_{en2} - d_{fn2}}{2m_n} - \left[\frac{\pi}{4} + \left(\frac{h_{ao2}}{m_n} - \frac{d_{en2} - d_{fn2}}{2m_2} \right) \tan \alpha_n \right] \tan \alpha_n - \frac{\rho_{ao2}}{m_n} \left(1 - \sin \frac{\pi}{6} \right)$$

where $\alpha_{F en}$ is taken as being equal to α_n

$$\rho_{F2} = \frac{\rho_{ao2}}{2}$$

d_{en2} is calculated as d_{en} for external gears, and

$$d_{fn} = d - d_f - d_n.$$

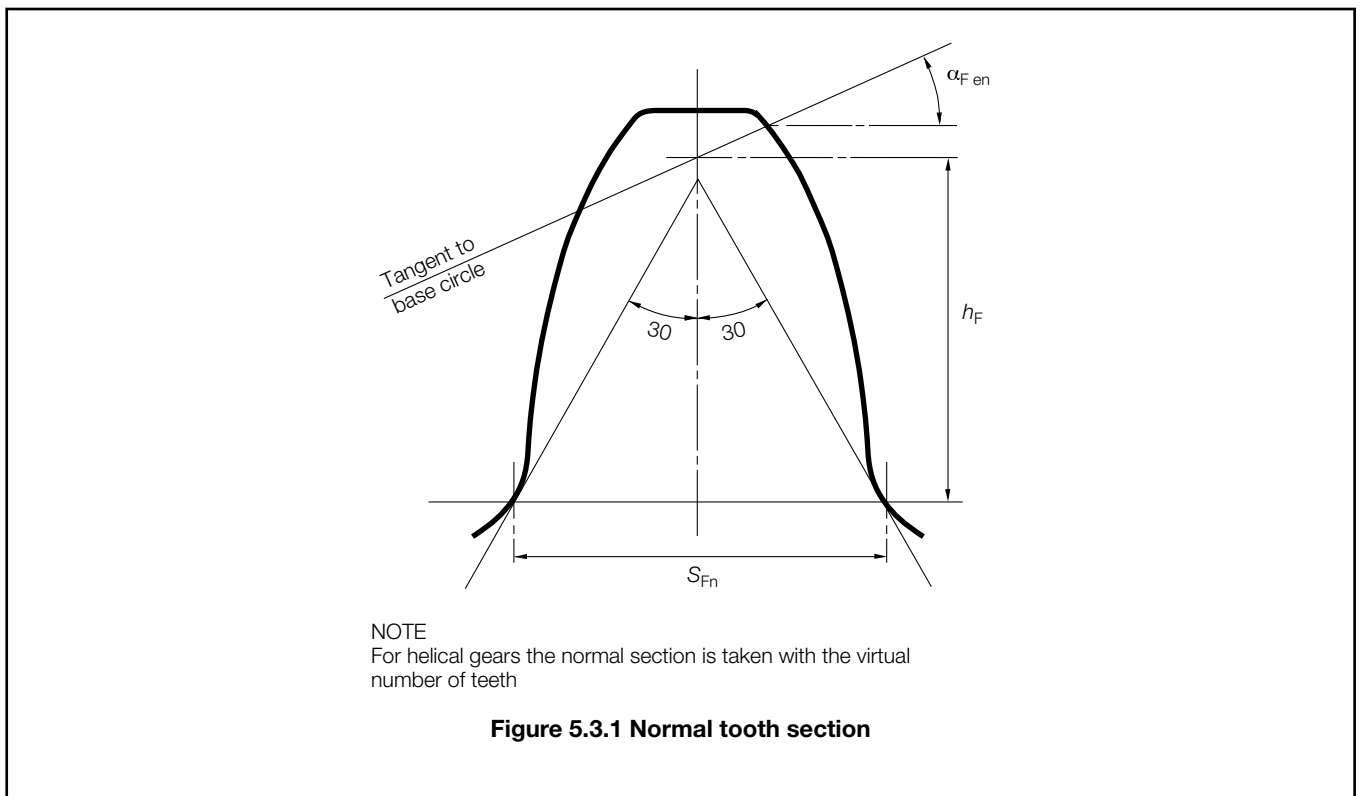

3.5.4 Stress concentration factor, Y_s

$$Y_s = (1, 2 + 0, 13L)q \left(\frac{1}{1, 21 + 2, 3/L} \right)_s$$

where

$$L = \frac{S_{Fn}}{h_F}$$

$$q_s = \frac{S_{Fn}}{2_{pf}}$$

when $q_s < 1$ the value of Y_s is to be specially considered.

The formula for Y_s is applicable to external gears with $\alpha_n = 20^\circ$ but may be used as an approximation for other pressure angles and internal gears.

3.5.5 Helix angle factor Y_β

$$Y_\beta = 1 - \left(\epsilon_\beta \frac{\beta}{120} \right), \text{ if } \epsilon_\beta > 1 \text{ let } \epsilon_\beta = 1$$

but $Y_\beta \geq 1 - 0,25 \quad 3_\beta \geq 0,75$.

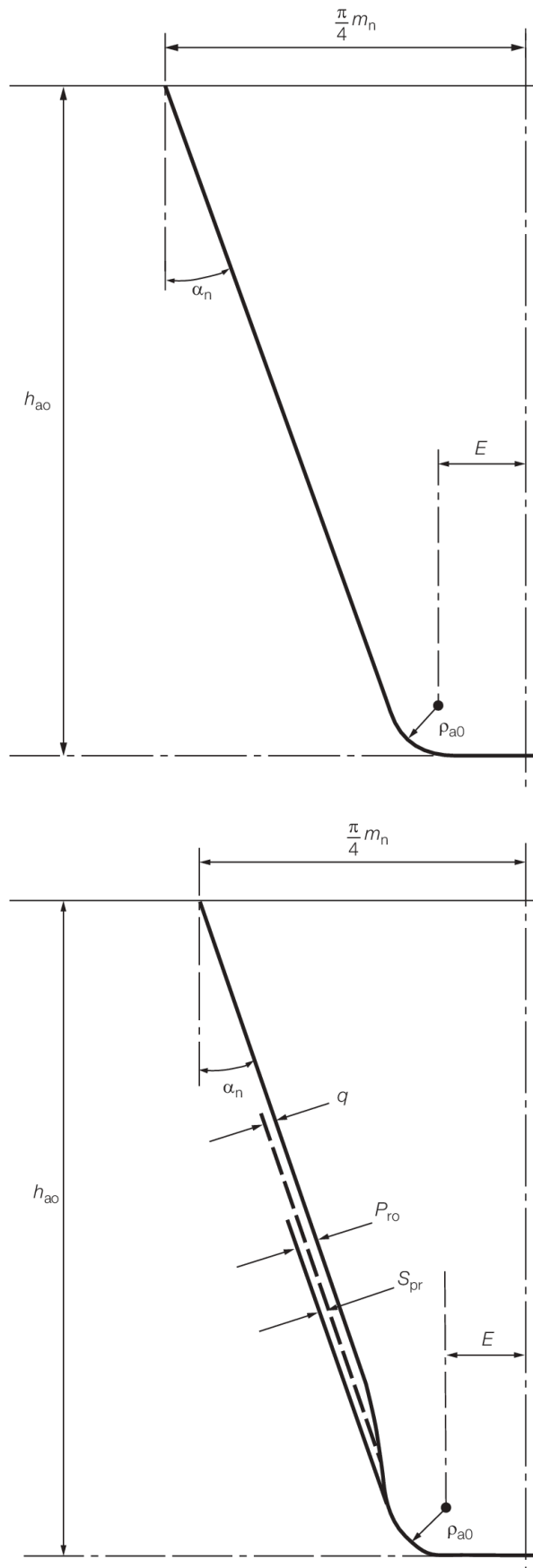

NOTES

1. Dimensions shown on rack profile of tooth
2. $S_{pr} = P_{ro} - q$

Figure 5.3.2 External tooth forms

3.5.6 Rim thickness factor, Y_B

Factor Y_B is to be determined as follows:

(a) For external gears

If $S_R/h \geq 1,2$ then $Y_B = 1$

If $0,5 < S_R/h < 1,2$ then $Y_B = 1,6 \cdot \ln \left(2,242 \frac{h}{S_R} \right)$

Where

S_R = rim thickness of external gears, mm

The case $S_R/h \leq 0,5$ is to be avoided.

(b) For internal gears

If $S_R/m_n \geq 3,5$ then $Y_B = 1$

If $1,75 < S_R/m_n < 3,5$ then $Y_B = 1,15 \cdot \ln \left(8,324 \frac{m_n}{S_R} \right)$

where

S_R = rim thickness of internal gears, mm

The case $S_R/m_n \leq 1,75$ is to be avoided.

3.5.7 Deep tooth factor Y_{DT}

The deep tooth factor, Y_{DT} , adjusts the root stress to take into account high precision gears and contact ratios within the range of virtual contact ratio $2,05 \leq \epsilon_{an} \leq 2,05$ where:

$$\epsilon_{an} = \frac{\epsilon \alpha}{\cos^2 \beta_b}$$

Factor Y_{DT} is to be determined from *Table 5.3.9 Values of deep tooth factor, Y_{DT}* :

Table 5.3.9 Values of deep tooth factor, Y_{DT}

	Y_{DT}
ISO Accuracy Grade ≤ 4 and $\epsilon_{an} > 2,5$	0,7
ISO Accuracy Grade ≤ 4 and $2,05 < \epsilon_{an} \leq 2,5$	$2,366 - 0,666 \cdot \epsilon_{an}$
In all other cases	1,0

3.5.8 Relative notch sensitivity factor, $Y_{\delta rel T}$

$$Y_{\delta rel T} = \frac{1 + \sqrt{0,2 \rho' (1 + 2q_s)}}{1 + \sqrt{1,2 \rho'}}$$

ρ' = slip-layer thickness is to be taken from *Table 5.3.10 Slip-layer thickness, ρ'*

Table 5.3.10 Slip-layer thickness, ρ'

Material	ρ' , (mm)	
Case-hardened steels, flame or induction-hardened steels	0,0030	
Through-hardened steels, yield point $R_e =$	500 N/mm ²	0,0281
	600 N/mm ²	0,0194
	800 N/mm ²	0,0064

	1000 N/mm ²	0,0014
Nitrided steels		0,1005
Note: The given values of ρ' can be interpolated for values of R_e not stated above		

3.5.9 Relative surface finish factor, Y_{RrelT}

$$Y_{RrelT} = 1,674 - 0,529 (6R_a + 1)^{0,1} \text{ for through-hardened, carburised and induction hardened steels, and}$$

$$Y_{RrelT} = 4,299 - 3,259 (6R_a + 1)^{0,005} \text{ for nitrided steels.}$$

3.5.10 Size factor, Y_x

$$Y_x = 1,00, \text{ when } m_n \leq 5$$

$$Y_x = 1,03 - 0,006m_n \text{ for through hardened steels}$$

$$Y_x = 0,85, \text{ when } m_n \geq 30$$

$$Y_x = 1,05 - 0,01m_n \text{ for surface-hardened steels}$$

$$Y_x = 0,80, \text{ when } m_n \geq 25.$$

3.5.11 Design factor, Y_D

$$Y_D = 0,83 \text{ for gears treated with a controlled shot peening process}$$

$$Y_D = 1,5 \text{ for idler gears}$$

$$Y_D = 1,25 \text{ for shrunk on gears, or}$$

$$Y_D = 1 + \frac{0,2d_s^2 d P_f b}{F_t \sigma_{Flim} (d_f^2 - d_s^2)}, \text{ otherwise}$$

$$Y_D = 1,00.$$

3.6 Factors of safety

3.6.1 Factors of safety are shown in *Table 5.3.7 Factors of safety*.

3.7 Design of enclosed gear shafting

3.7.1 This sub-Section is applicable to solid shafting enclosed within the gearcase of single input/single output gearing. Alternative configurations and hollow shaft designs, final gear wheel shafts and thrust shafts are to be in accordance with *Pt 5, Ch 6, 3.3 Final gear wheel shafts* and *Pt 5, Ch 6, 3.4 Thrust shafts* respectively.

3.7.2 The diameter of the enclosed gear shafting adjacent to the pinion or wheel is to be not less than the greater of d_b or d_t , where:

$$d_b = 365 \left(\frac{P L}{R d_w S_b} \right)^{1/3} \left(1 + \left(\frac{\tan \alpha_n}{\cos \beta} + \frac{\tan \beta d_w}{L} \right)^2 \right)^{1/6}$$

$$d_t = 365 \left(\frac{P}{R S_s} \right)^{1/3}$$

= where

$$S_b = 45 + 0,24 (\sigma_u - 400) \text{ and}$$

$$S_s = 42 + 0,09 (\sigma_u - 400)$$

L = span between shaft bearing centres, in mm

α_n = normal pressure angle at the gear reference diameter, in degrees

β = helix angle at the gear reference diameter, in degrees

d_w = pitch circle diameter of the gear teeth, in mm

σ_u = specified minimum tensile strength of the shaft material, in N/mm².

Note P in kW and R in rpm are as defined in *Pt 5, Ch 1, 3.3 Power ratings*.

Numerical value used for σ_u is not to exceed 800 N/mm² for gear and thrust shafts.

3.7.3 For the purposes of the above it is assumed that the pinion or wheel is mounted symmetrically spaced between bearings.

3.7.4 Outside a length equal to the required diameter at the pinion or wheel, the diameter may be reduced, if applicable, to that required for d_t .

3.7.5 For bevel gear shafts, where a bearing is located adjacent to the gear section, the diameter of the shaft is to be not less than d_t . Where a bearing is not located adjacent to the gear the diameter of the shaft will be specially considered.

■ Section 4 Construction

4.1 Gear wheels and pinions

4.1.1 Where castings are used for wheel centres, any radial slots in the periphery are to be fitted with permanent chocks before shrinking-on the rim.

4.1.2 Where bolts are used to secure side plates to rim and hub, the bolts are to be a tight fit in the holes and the nuts are to be suitably locked by means other than welding.

4.1.3 Where welding is employed in the construction of wheels, the welding procedure is to be approved by the Surveyors before work is commenced. For this purpose, welding procedure approval tests are to be carried out with satisfactory results. Such tests are to be representative of the joint configuration and materials. Wheels are to be stress relieved after welding. All welds are to have a satisfactory surface finish and contour. Magnetic particle or liquid penetrant examination of all important welded joints is to be carried out to the satisfaction of the Surveyors.

4.1.4 In general, arrangements are to be made so that the interior structure of the wheel may be examined. Alternative proposals will be specially considered.

4.2 Accuracy of gear cutting and alignment

4.2.1 The machining accuracy (Q grade) of pinions and wheels is to be demonstrated to the satisfaction of the Surveyors. For this purpose records of measurements should be available for review by Surveyors on request.

4.2.2 Where allowance has been given for end relief or helix correction the normal shop meshing tests are to be supplemented by tooth alignment traces or other approved means to demonstrate the effectiveness of such modifications.

4.3 Gearcases

4.3.1 Gearcases and their supports are to be designed sufficiently stiff such that misalignment at the mesh due to movements of the external foundations and the thermal effects under all conditions of service do not disturb the overall tooth contact.

4.3.2 For gearcases fabricated by fusion welding the carbon content of steels should generally not exceed 0,23 per cent. Steels with higher carbon content may be approved subject to satisfactory results from weld procedure tests.

4.3.3 Gearcases are to be stress relief heat treated on completion of all welding.

4.3.4 Inspection openings are to be provided at the peripheries of gearcases to enable the teeth of pinions and wheels to be readily examined. Where the construction of gearcases is such that sections of the structure cannot readily be moved for

inspection purposes, access openings of adequate size are also to be provided at the ends of the gearcases to permit examination of the structure of the wheels. Their attachment to the shafts is to be capable of being examined by removal of bearing caps or by equivalent means.

■ **Section 5
Tests**

5.1 Balance of gear pinions and wheels

5.1.1 All rotating elements, (e.g. pinion and wheel shaft assemblies and coupling parts), are to be appropriately balanced.

5.1.2 The permissible residual unbalance, U , is defined as follows:

$$U = \frac{60m}{N} \times 10^3 \text{ gmm for } N \leq 3000$$

$$U = \frac{24m}{N} \times 10^3 \text{ gmm for } N > 3000$$

where

m = mass of rotating element, kg

N = maximum service rev/min of the rotating element.

5.1.3 Where the size or geometry of a rotating element precludes measurement of the residual unbalance, a full speed running test of the assembled gear unit at the manufacturer's works will normally be required to demonstrate satisfactory operation.

5.2 Meshing tests

5.2.1 Initially, meshing gears are to be carefully matched on the basis of the accuracy measurements taken. The alignment is to be demonstrated in the workshop by meshing in the gearbox without oil clearance in the bearings. Meshing is to be carried out with the gears locating in their light load positions and a load sufficient to overcome pinion weight and axial movement is to be imposed.

5.2.2 The gears are to be suitably coated to demonstrate the contact marking. The marking is to reflect the accuracy grade specified and end relief of helix correction, where these have been applied.

5.2.3 For gears without helix correction the marking is to be not less than shown in *Table 5.5.1 No load tooth contact marking*.

Table 5.5.1 No load tooth contact marking

ISO accuracy grade	Contact marking area
$Q \leq 5$	$40\%h_w$ for $50\%b$ and $20\%h_w$ for a further $40\%b$
$Q \geq 6$	$40\%h_w$ for $35\%b$ and $20\%h_w$ for a further $35\%b$

Note 1. Where b is face width and h_w is working tooth depth.

Note 2. For spur gears the values of h_w should be increased by a further 10%.

5.2.4 For gears with end relief of helix correction the marking is to correspond to the designed no load contact pattern.

5.2.5 A permanent record is to be made of the meshing contact for purpose of checking the alignment when installed on board ship.

5.2.6 The full load tooth contact marking is to be not less than shown in *Table 5.5.2 Full load tooth contact marking*.

Table 5.5.2 Full load tooth contact marking

ISO accuracy grade	Contact marking area
$Q \leq 5$	$70\%h_w$ for $60\% b$ and $50\%h_w$ for a further $30\%b$
$Q \geq 6$	$60\%h_w$ for $45\% b$ and $40\%h_w$ for a further $35\%b$

Note 1. Where b is face width and h_w is working tooth depth.

Note 2. For spur gears the values of h_w should be increased by a further 10%.

5.3 Backlash

5.3.1 The normal backlash between any pair of gears should not be less than:

$$\frac{a \alpha_n}{90\,000} + 0,1 \text{ mm}$$

5.3.2 The normal backlash is not to exceed three times the value calculated in *Pt 5, Ch 5, 5.3 Backlash 5.3.1*.

5.4 Alignment

5.4.1 Reduction gears with sleeve bearings, for main and auxiliary purposes are to be provided with means for checking the internal alignment of the various elements in the gearcases.

5.4.2 In the case of separately mounted reduction gearing for main propulsion, means are to be provided by the gear manufacturer to enable the Surveyors to verify that no distortion of the gearcase has taken place, when chocked and secured to its seating on board ship.

5.4.3 Further requirements are given in *Pt 5, Ch 8, 5 Shaft alignment*.

■ Section 6 Control and monitoring

6.1 General

6.1.1 Control engineering systems are to be in accordance with *Pt 6, Ch 1 Control Engineering Systems*.

6.1.2 All main and auxiliary gear units intended for essential services are to be provided with means of indicating the lubricating oil pressure supply to them. Audible and visual alarms are to be fitted to give warning of an appreciable reduction in pressure of the lubricating oil supply. Further, these alarms are to be actuated from the outlet side of any restrictions, such as filters, coolers, etc.

6.2 Unattended machinery

6.2.1 Where machinery is fitted with automatic or remote controls so that under normal operating conditions it does not require any manual intervention by the operators, it is to be provided with the alarms and safety arrangements required by *Pt 5, Ch 5, 6.2 Unattended machinery*, as appropriate. Alternative arrangements which provide equivalent safeguards will be considered.

6.2.2 Where machinery specified in this Section is required to be provided with a standby pump, the standby pump is to start automatically if the discharge pressure from the working pumps falls below a predetermined value.

6.2.3 Where a first stage alarm together with a second stage alarm and automatic shutdown of machinery are required in the relevant Tables of this Section, the sensors and circuits utilised for the second stage alarm and automatic shutdown are to be independent of those required for the first stage alarm.

6.2.4 Alarms and safeguards are indicated in *Table 5.6.1 Main and auxiliary gear units: Alarms and safeguards*.

Table 5.6.1 Main and auxiliary gear units: Alarms and safeguards

Item	Alarm	Note
Lubricating oil sump level	Low	—
Lubricating oil inlet pressure *	1st stage low	Slow-down
Lubricating oil inlet pressure *	2nd stage low	Automatic shutdown
Lubricating oil inlet temperature *	High	—
Thrust bearing temperature *	High	Slow-down
Note For transmitted powers of 1500 kW or less, only the items marked * are required.		

■ *Section 7*

Cross-reference

7.1 For lubricating oil systems, see *Pt 5, Ch 14 Machinery Piping Systems*.

*Section***Scope**

- 1 **Plans and particulars**
- 2 **Materials**
- 3 **Design**
- 4 **Control and Monitoring**

**Scope**

The requirements of this Chapter relate, in particular, to formulae for determining the diameters of shafting for main propulsion installations, but requirements for couplings, coupling bolts, keys, keyways, sternbushes and other associated components are also included. The diameters may require to be modified as a result of alignment considerations and vibration characteristics, see *Pt 5, Ch 8 Shaft Vibration and Alignment*, or the inclusion of stress raisers, other than those contained in this Chapter.

Alternative calculation methods for determining the diameters of shafting for main propulsion and their permissible torsional stresses will be considered by LR. Any alternative calculation method is to include all relevant loads on the complete dynamic shafting system under all permissible operating conditions. Consideration is to be given to the dimensions and arrangements of all shaft connections. Moreover, an alternative calculation method is to take into account design criteria for continuous and transient operating loads (dimensioning for fatigue strength) and for peak operating loads (dimensioning for yield strength). The fatigue strength analysis may be carried out separately for different load assumptions, for example as given below.

Shafts complying with the applicable Rules in *Pt 5, Ch 6 Main Propulsion Shafting* and *Pt 5, Ch 8 Shaft Vibration and Alignment* satisfy the following:

- (a) Low cycle fatigue criterion (typically $<10^4$), i.e. the primary cycles represented by zero to full load and back to zero, including reversing torque if applicable. This is addressed by the formulas in *Pt 5, Ch 6, 3.1 Intermediate shafts*, *Pt 5, Ch 6, 3.5 Screwshafts and tube shafts* and *Pt 5, Ch 6, 3.6 Hollow shafts*.
- (b) High cycle fatigue criterion (typically $\gg 10^7$), i.e. torsional vibration stresses permitted for continuous operation as well as reverse bending stresses and the accumulated fatigue due to torsional vibration when passing through a barred speed range or any other transient condition with associated stresses beyond those permitted for continuous operation. This is addressed by the formulas in *Pt 5, Ch 8, 2.5 Limiting stress in propulsion shafting*. The influence of reverse bending stresses is addressed by the safety margins inherent in the formulas from *Pt 5, Ch 6, 3.1 Intermediate shafts*, *Pt 5, Ch 6, 3.5 Screwshafts and tube shafts* and *Pt 5, Ch 6, 3.6 Hollow shafts*.

*Section 1***Plans and particulars****1.1 Shafting plans**

1.1.1 The following plans, together with the necessary particulars of the machinery, including the maximum power and revolutions per minute, are to be submitted for consideration before the work is commenced:

- Final gear shaft.
- Thrust shaft.
- Intermediate shafting.
- Tube shaft, where applicable.
- Screwshaft.
- Screwshaft oil gland.

- Sternbush.

1.1.2 The specified minimum tensile strength of each shaft is to be stated.

1.1.3 In addition, a shafting arrangement plan indicating the relative positions of the main engines, flywheel, flexible coupling, gearing, thrust block, line shafting and bearings, sterntube, 'A' bracket and propeller, as applicable, is to be submitted for information.

■ Section 2 Materials

2.1 Materials for shafts

2.1.1 The specified minimum tensile strength of forgings for shafts is to be selected within the following general limits:

- (a) Carbon and carbon-manganese steel – 400 to 760 N/mm² (41 to 77,5 kgf/mm²). See also Pt 5, Ch 6, 3.5 Screwshafts and tube shafts 3.5.1.
- (b) Alloy steel – not exceeding 800 N/mm² (82 kgf/mm²).

2.1.2 Where it is proposed to use alloy steel, details of the chemical composition, heat treatment and mechanical properties are to be submitted for approval.

2.1.3 Where shafts may experience vibratory stresses close to the permissible stresses for transient operation, the materials are to have a specified minimum tensile strength of 500 N/mm² (51 kgf/mm²).

2.1.4 Where materials with greater specified or actual tensile strengths than the limitations given above are used, reduced shaft dimensions or higher permissible vibration stresses are not acceptable when derived from the formulae used in Pt 5, Ch 6, 3.1 Intermediate shafts, Pt 5, Ch 6, 3.5 Screwshafts and tube shafts, Pt 5, Ch 6, 3.6 Hollow shafts and Pt 5, Ch 8, 2.5 Limiting stress in propulsion shafting.

2.2 Ultrasonic tests

2.2.1 Ultrasonic tests are required on shaft forgings where the diameter is 250 mm or greater.

■ Section 3 Design

3.1 Intermediate shafts

3.1.1 The diameter, d , of the intermediate shaft is to be not less than determined by the following formula:

$$d = Fk \sqrt[3]{\frac{P}{R} \left(\frac{560}{\sigma_u + 160} \right)} \text{ mm}$$

$$\left(d = Fk \sqrt[3]{\frac{H}{R} \left(\frac{57}{\sigma_u + 16} \right)} \text{ mm} \right)$$

where

$k = 1,0$ for shafts with integral coupling flanges complying with 3.7 or with shrink fit couplings, see Pt 5, Ch 6, 3.1 Intermediate shafts 3.1.4

where

- = 1,10 for shafts with keyways in tapered or cylindrical connections, where the fillet radii in the transverse section of the bottom of the keyway are to be not less than $0,0125d$
- = 1,10 for shafts with transverse or radial holes where the diameter of the hole (d_h) is not greater than $0,3d$
- = 1,20 for shafts with longitudinal slots see *Pt 5, Ch 6, 3.1 Intermediate shafts 3.1.6*
- F = 95(86) for turbine installations, electric propulsion installations and oil engine installations with slip type couplings
- = 100 (90,5) for other oil engine installations

P (H) and R are defined in *Pt 5, Ch 1, 3.3 Power ratings* (losses in gearboxes and bearings are to be disregarded)

σ_u = specified minimum tensile strength of the shaft material, in N/mm^2 (kgf/mm^2), see *Pt 5, Ch 6, 2.1 Materials for shafts 2.1.3*.

After a length of $0,2d$ from the end of a keyway, transverse hole or radial hole and $0,3d$ from the end of a longitudinal slot, the diameter of the shaft may be gradually reduced to that determined with $k = 1,0$.

3.1.2 For shafts with design features other than stated in *Pt 5, Ch 6, 3.1 Intermediate shafts 3.1.1*, the value of k will be specially considered.

3.1.3 The Rule diameter of the intermediate shaft for oil engines, turbines and electric propelling motors may be reduced by 3,5 per cent for ships classed exclusively for smooth water service, and by 1,75 per cent for ships classed exclusively for service on the Great Lakes.

3.1.4 For shrink fit couplings k refers to the plain shaft section only. Where shafts may experience vibratory stresses close to the permissible stresses for continuous operation, an increase in diameter to the shrink fit diameter is to be provided, e.g. a diameter increase of 1 to 2 per cent and a blending radius as described in *Pt 5, Ch 6, 3.7 Couplings and transitions of diameters*.

3.1.5 Keyways are in general not to be used in installations with a barred speed range.

3.1.6 The application of $k = 1,20$ is limited to shafts with longitudinal slots having a length of less than $0,8d_o$ and a width greater than $0,15d_o$ and a diameter of central hole d_i of less than $0,7d_o$ see *Pt 5, Ch 6, 3.6 Hollow shafts*. The end rounding of the slot is not to be less than half the width. An edge rounding should preferably be avoided as this increases the stress concentration slightly. The values of c_K , see *Table 8.2.1 Ck factors in Pt 5, Ch 8 Shaft Vibration and Alignment*, are valid for 1, 2 and 3 slots, i.e. with slots at 360, 180 and 120 degrees apart respectively.

3.2 Gear quill shafts

3.2.1 The diameter of the quill shaft is to be not less than given by the following formula:

$$\text{Diameter of quill shaft} = 101 \sqrt[3]{\frac{P400}{R \sigma_u}} \text{ mm}$$

$$\left(91 \sqrt[3]{\frac{H41}{R \sigma_u}} \text{ mm} \right)$$

where

P (H) and R are as defined in *Pt 5, Ch 1, 3.3 Power ratings*.

σ_u = specified minimum tensile strength of the material, in N/mm^2 (kgf/mm^2) but is not to exceed 1100 N/mm^2 (112 kgf/mm^2).

3.3 Final gear wheel shafts

3.3.1 Where there is only one pinion geared into the final wheel, or where there are two pinions which are set to subtend an angle at the centre of the shaft of less than 120 degrees, the diameter of the shaft at the final wheel and the adjacent journals is to be not less than 1,15 times that required for the intermediate shaft.

3.3.2 Where there are two pinions geared into the final wheel opposite, or nearly opposite, to each other, the diameter of the shaft at the final wheel and the adjacent journals is to be not less than 1,1 times that required for the intermediate shaft.

3.3.3 In both *Pt 5, Ch 6, 3.3 Final gear wheel shafts 3.3.1* and *Pt 5, Ch 6, 3.3 Final gear wheel shafts 3.3.2*, abaft the journals, the shaft may be gradually tapered down to the diameter required for an intermediate shaft determined according to 3.1, where σ_u is to be taken as the specified minimum tensile strength of the final wheel shaft material, in N/mm² (kgf/mm²).

3.4 Thrust shafts

3.4.1 The diameter at the collars of the thrust shaft transmitting torque, or in way of the axial bearing where a roller bearing is used as a thrust bearing, is to be not less than that required for the intermediate shaft in accordance with 3.1 with a k value of 1,10. Outside a length equal to the thrust shaft diameter from the collars, the diameter may be tapered down to that required for the intermediate shaft with a k value of 1,0. For the purpose of the foregoing calculations, σ_u is to be taken as the minimum tensile strength of the thrust shaft material, in N/mm² (kgf/mm²).

3.5 Screwshafts and tube shafts

3.5.1 The diameter, d_p of the screwshaft immediately forward of the forward face of the propeller boss or, if applicable, the forward face of the screwshaft flange, is to be not less than determined by the following formula:

$$d_p = 100k \sqrt[3]{\frac{P}{R} \left(\frac{560}{\sigma_u + 160} \right)} \text{ mm}$$

$$\left(d_p = 90, 5k \sqrt[3]{\frac{P}{R} \left(\frac{57}{\sigma_u + 16} \right)} \text{ mm} \right)$$

where

- $k = 1,22$ for a shaft carrying a keyless propeller fitted on a taper, or where the propeller is attached to an integral flange, and where the shaft is fitted with a continuous liner, a coating of an approved type, or is oil lubricated and provided with an approved type of oil sealing gland
- $= 1,26$ for a shaft carrying a keyed propeller and where the shaft is fitted with a continuous liner, a coating of an approved type, or is oil lubricated and provided with an approved type of oil sealing gland

P (H) and R are defined in *Pt 5, Ch 1, 3.3 Power ratings*, (losses in gearboxes and bearings are to be disregarded)

σ_u = specified minimum tensile strength of the shaft material, in N/mm² (kgf/mm²) but is not to be taken as greater than 600 N/mm² (61 kgf/mm²). See *Pt 5, Ch 6, 2.1 Materials for shafts 2.1.3*

3.5.2 The diameter, d_p of the screwshaft determined in accordance with the formula in *Pt 5, Ch 6, 3.5 Screwshafts and tube shafts 3.5.1* is to extend over a length not less than that to the forward edge of the bearing immediately forward of the propeller or $2,5d_p$ whichever is the greater.

3.5.3 The diameter of the portion of the screwshaft and tube shaft, forward of the length required by *Pt 5, Ch 6, 3.5 Screwshafts and tube shafts 3.5.2* to the forward end of the forward stern tube seal, is to be determined in accordance with the formula in *Pt 5, Ch 6, 3.5 Screwshafts and tube shafts 3.5.1* with a k value of 1,15. The change of diameter from that determined with $k = 1,22$ or 1,26 to that determined with $k = 1,15$ should be gradual, see *Pt 5, Ch 6, 3.7 Couplings and transitions of diameters*.

3.5.4 Screwshafts which run in sterntubes and tube shafts may have the diameter forward of the forward stern tube seal gradually reduced to the diameter of the intermediate shaft. Abrupt changes in shaft section at the screwshaft/tube shaft to intermediate shaft couplings are to be avoided see *Pt 5, Ch 6, 3.7 Couplings and transitions of diameters*.

3.5.5 Unprotected screwshafts and tube shafts of corrosion-resistant material will be specially considered.

3.5.6 For shafts of non-corrosion-resistant materials which are exposed to sea-water, the diameter of the shaft is to be determined in accordance with the formula in Pt 5, Ch 6, 3.5 Screwshafts and tube shafts 3.5.1 with a k value of 1,26 and σ_u taken as 400 N/mm² (41 kgf/mm²).

3.6 Hollow shafts

3.6.1 Where the thrust, intermediate and tube shafts and screwshafts have central holes, the outside diameters of the shafts are to be not less than given by the following formula:

$$d_o = d \sqrt[3]{\frac{1}{1 - \left(\frac{d_i}{d_o}\right)^4}}$$

where

d_o = outside diameter, in mm

d = Rule size diameter of solid shaft, in mm

d_i = diameter of central hole, in mm.

However, where the diameter of the central hole does not exceed 0,4 times the outside diameter, no increase over Rule size need be provided.

3.7 Couplings and transitions of diameters

3.7.1 The minimum thicknesses of the coupling flanges are to be equal to the diameters of the coupling bolts at the face of the couplings as required by Pt 5, Ch 6, 3.8 Coupling bolts and, for this purpose, the minimum tensile strength of the bolts is to be taken as equivalent to that of the shafts. For intermediate shafts, thrust shafts and the inboard end of the screwshaft, the thickness of the coupling flange is in no case to be less than 0,20 of the diameter of the intermediate shaft as required by Pt 5, Ch 6, 3.1 Intermediate shafts.

3.7.2 The fillet radius at the base of the coupling flange is to be not less than 0,08 of the diameter of the shaft at the coupling but, in the case of crankshafts, the fillet radius at the centre coupling flanges may be 0,05 of the diameter of the shaft at the coupling. The fillets are to have a smooth finish and are not to be recessed in way of nut and bolt heads.

3.7.3 Where the propeller is attached by means of a flange, the thickness of the flange is to be not less than 0,25 of the actual diameter of the adjacent part of the screwshaft. The fillet radius at the base of the coupling flange is to be not less than 0,125 of the diameter of the shaft at the coupling.

3.7.4 All couplings which are attached to shafts are to be of approved dimensions.

3.7.5 Where couplings are separate from the shafts, provision is to be made to resist the astern pull.

3.7.6 Where a coupling is shrunk on to the parallel portion of a shaft or is mounted on a slight taper, e.g. by means of the oil pressure injection method, full particulars of the coupling including the interference fit are to be submitted for special consideration.

3.7.7 Transitions of diameters are to be designed with either a smooth taper or a blending radius. In general, a blending radius equal to the change in diameter is recommended.

3.8 Coupling bolts

3.8.1 Close tolerance fitted bolts transmitting shear are to have a diameter, at the joining faces of the couplings not less than given by the following formula:

$$\text{Diameter of coupling bolts} = \sqrt{\frac{240 \cdot 10^6 \cdot P}{nD \cdot \sigma_u \cdot R}} \text{ mm}$$

where

n = number of bolts in the coupling

D = pitch circle diameter of bolts, in mm

where

σ_u = specified minimum tensile strength of bolts, in N/mm²

$P(H)$ and R = are as defined in *Pt 5, Ch 1, 3.3 Power ratings*.

3.8.2 At the joining faces of couplings, other than within the crankshaft and at the thrust shaft/crankshaft coupling, the Rule diameter of the coupling bolts defined in *Pt 5, Ch 6, 3.8 Coupling bolts 3.8.1* may be reduced by 5,2 per cent for ships classed exclusively for smooth water service, and 2,6 per cent for ships classed exclusively for service on the Great Lakes.

3.8.3 Where dowels or expansion bolts are fitted to transmit torque in shear they are to comply with the requirements of *Pt 5, Ch 6, 3.8 Coupling bolts 3.8.1*. The expansion bolts are to be installed, and the bolt holes in the flanges are to be correctly aligned, in accordance with manufacturer's instructions.

3.8.4 The minimum diameter of tap bolts or of bolts in clearance holes at the joining faces of coupling flanges, pretensioned to 70 per cent of the bolt material yield strength value, is not to be less than:

$$d_R = 1,348 \sqrt{\left(\frac{120 \cdot 10^6 \cdot FP(1+C)}{RD} + Q \right) \frac{1}{n \sigma_y}}$$

where d_R is taken as the lesser of:

- (a) Mean of effective (pitch) and minor diameters of the threads.
- (b) Bolt shank diameter away from threads. (Not for waisted bolts which will be specially considered.)

$P(H)$ and R are as defined in *Pt 5, Ch 1, 3.3 Power ratings*.

F = 2,5 where the flange connection is not accessible from within the ship

= 2,0 where the flange connection is accessible from within the ship

C = ratio of vibratory/mean torque values at the rotational speed being considered

D = pitch circle diameter of bolt holes, in mm

Q = external load on bolt in N (+ve tensile load tending to separate flange, -ve)

n = number of tap or clearance bolts

σ_y = bolt material yield stress in N/mm².

3.8.5 Consideration will be given to those arrangements where the bolts are pretensioned to loads other than 70 per cent of the material yield strength.

3.8.6 Where clamp bolts are fitted they are to comply with the requirements of *Pt 5, Ch 6, 3.8 Coupling bolts 3.8.4* and are to be installed, and the bolt holes in the flanges correctly aligned, in accordance with manufacturer's instructions.

3.9 Bronze or gunmetal liners on shafts

3.9.1 The thickness, t , of liners fitted on screwshafts or on tube shafts, in way of the bushes, is to be not less, when new, than given by the following formula:

$$t = \frac{D + 230}{32} \text{ mm}$$

where

t = thickness of the liner, in mm

D = diameter of the screwshaft or tube shaft under the liner, in mm.

3.9.2 The thickness of a continuous liner between the bushes is to be not less than 0,75 t .

3.9.3 Continuous liners should preferably be cast in one piece.

3.9.4 Where liners consist of two or more lengths, these are to be butt welded together. In general, the lead content of the gunmetal of each length forming a butt welded liner is not to exceed 0,5 per cent. The composition of the electrodes or filler rods is to be substantially lead-free.

3.9.5 The circumferential butt welds are to be of multi-run, full penetration type. Provision is to be made for contraction of the weld by arranging for a suitable length of the liner containing the weld, if possible about three times the shaft diameter, to be free of the shaft. To prevent damage to the surface of the shaft during welding, a strip of heat resisting material covered by a copper strip should be inserted between the shaft and the liner in way of the joint. Other methods for welding this joint may be accepted if approved. The welding is to be carried out by an approved method and to the Surveyor's satisfaction.

3.9.6 Each continuous liner or length of liner is to be tested by hydraulic pressure to 2,0 bar (2,0 kgf/cm²) after rough machining.

3.9.7 Liners are to be carefully shrunk on, or forced on, to the shafts by hydraulic pressure. Pins are not to be used to secure the liners.

3.9.8 Effective means are to be provided for preventing water from reaching the shaft at the part between the after end of the liner and the propeller boss.

3.10 Keys and keyways

3.10.1 Round ended or sled-runner ended keys are to be used, and the keyways in the propeller boss and cone of the screwshaft are to be provided with a smooth fillet at the bottom of the keyways. The radius of the fillet is to be at least 0,0125 of the diameter of the screwshaft at the top of the cone. The sharp edges at the top of the keyways are to be removed.

3.10.2 Two screwed pins are to be provided for securing the key in the keyway, and the forward pin is to be placed at least one-third of the length of the key from the end. The depth of the tapped holes for the screwed pins is not to exceed the pin diameter, and the edges of the holes are to be slightly bevelled.

3.10.3 The distance between the top of the cone and the forward end of the keyway is to be not less than 0,2 of the diameter of the screwshaft at the top of the cone.

3.10.4 The effective sectional area of the key in shear, is to be not less than $\frac{d^3}{2,6d_1}$ mm²

where

d = diameter, in mm, required for the intermediate shaft determined in accordance with 3.1, based on material having a specified minimum tensile strength of 400 N/mm² (41 kgf/mm²) and $k = 1$

d_1 = diameter of shaft at mid-length of the key, in mm.

3.11 Propellers

3.11.1 For keyed and keyless propellers, see Pt 5, Ch 7 Propellers.

3.12 Sternbushes

3.12.1 The length of the bearing in the sternbush next to and supporting the propeller is to be as follows:

- For water lubricated bearings which are lined with lignum vitae, rubber composition or staves of approved plastics material, the length is to be not less than four times the diameter required for the screwshaft under the liner.
- For water lubricated bearings lined with two or more circumferentially spaced sectors of an approved plastics material, in which it can be shown that the sectors operate on hydrodynamic principles, the length of the bearing is to be such that the nominal bearing pressure will not exceed 5,5 bar (5,6 kgf/cm²). The length of the bearing is to be not less than twice its diameter.
- For oil lubricated bearings of synthetic material the flow of lubricant is to be such that overheating, under normal operating conditions, cannot occur. The acceptable nominal bearing pressure will be considered upon application and is to be supported by the results of an agreed test programme. In general, the length of the bearing is not to be less than 2,0 times the rule diameter of the shaft in way of the bearing.
- For bearings which are white-metal lined, oil lubricated and provided with an approved type of oil sealing gland, the length of the bearing is to be approximately twice the diameter required for the screwshaft and is to be such that the nominal bearing pressure will not exceed 8,0 bar (8,1 kgf/cm²). The length of the bearing is to be not less than 1,5 times its diameter.

- (e) For bearings of cast iron and bronze which are oil lubricated and fitted with an approved oil sealing gland, the length of the bearing is, in general, to be not less than four times the diameter required for the screwshaft.
- (f) For bearings which are grease lubricated, the length of the bearing is to be not less than four times the diameter required for the screwshaft.

3.12.2 Forced water lubrication is to be provided for all bearings lined with rubber or plastics and for those bearings lined with lignum vitae where the shaft diameter is 380 mm or over. The supply of water may come from a circulating pump or other pressure source. Flow indicators are to be provided for the water service to plastics and rubber bearings. The water grooves in the bearings are to be of ample section and of a shape which will be little affected by wear, particularly for bearings of the plastics type.

3.12.3 Bearings of synthetic material are to be supplied finished machined to design dimensions within a rigid bush. Means are to be provided to prevent rotation of the lining within the bush during operation.

3.12.4 All sternbushes are to be adequately secured in the sterntube/housings.

3.12.5 The shut-off valve or cock controlling the supply of water is to be fitted direct to the after peak bulkhead, or to the sterntube where the water supply enters the sterntube forward of the bulkhead.

3.12.6 Oil sealing glands fitted in ships classed for unrestricted service must be capable of accommodating the effects of differential expansion between hull and line of shafting in sea temperatures ranging from arctic to tropical. This requirement applies particularly to those glands which span the gap and maintain oiltightness between the sterntube and the propeller boss.

3.12.7 Where a tank supplying lubricating oil to the sternbush is fitted, it is to be located above the load waterline and is to be provided with a low level alarm device in the engine room.

3.12.8 Where sternbush bearings are oil lubricated, provision is to be made for cooling the oil by maintaining water in the after peak tank above the level of the sterntube or by other approved means.

3.12.9 Means for ascertaining the temperature of the sternbush bearings are to be provided, e.g. monitoring of the temperature of the oil in the sterntube.

3.12.10 Where there is compliance with the terms of *Pt 5, Ch 6, 3.12 Sternbushes 3.12.1* and *Pt 5, Ch 6, 3.12 Sternbushes 3.12.1* to the Surveyor's satisfaction, a screwshaft will be assigned the notation **OG** in the *Supplement to the Register Book* for Periodical Survey purposes, see *Pt 1, Ch 3 Periodical Survey Regulations*.

3.12.11 Screwshafts which are grease lubricated are not eligible for the **OG** notation.

3.12.12 Where an ***IWS**. (In-water Survey) notation is to be assigned, see *Pt 1, Ch 2, 2.3 Class notations (hull) 2.3.11*, means are to be provided for ascertaining the clearance in the sternbush with the vessel afloat.

3.13 Vibration and alignment

3.13.1 For the requirements for torsional, axial and lateral vibration, and for alignment of the shafting, see *Pt 5, Ch 8 Shaft Vibration and Alignment*.

■ *Section 4*

Control and Monitoring

4.1 Screwshaft Condition Monitoring (SCM)

4.1.1 For vessels where the ShipRight descriptive note SCM (Screwshaft Condition Monitoring) is requested the requirements in either *Pt 5, Ch 6, 4.1 Screwshaft Condition Monitoring (SCM) 4.1.2* or *Pt 5, Ch 6, 4.1 Screwshaft Condition Monitoring (SCM) 4.1.3* are to be satisfied.

4.1.2 Oil lubricated bearings:

- (a) Arrangements are to be provided to allow analysis of the lubricating oil. Oil samples are to be taken under service conditions and are to be representative of the oil within the sterntube, sampling arrangements are to meet the requirements of *Pt 5, Ch 14, 8.12 Lubricating oil contamination 8.12.6*.
- (b) Bearing temperature sensor arrangement is to be designed with either:
- (i) sufficient redundancy in the event of failure of one sensing element and/or its associated cabling; or

- (ii) means to allow replacement of a damaged sensor without requiring dry-docking or divers.
- (c) Facilities are to be provided for measurement of bearing wear.
- (d) Approved oil glands that are capable of being replaced without removal of the propeller or withdrawal of the screwshaft are to be fitted.

4.1.3 Water lubricated bearings:

- (a) An approved means of monitoring and recording variations in the flow rate of lubricating water using two independent sensors is to be provided.
- (b) An approved means of monitoring and recording variations in the shaft power transmission is to be provided.
- (c) The maximum permitted wear of the sternbush is to be indicated by the manufacturer. The maximum wear allowance is to include both the absolute maximum permitted wear and the wear at which it is recommended to carry out an inspection and maintenance. An approved means of monitoring bearing wear is to be provided. An alignment analysis considering both the newly installed clearance and the proposed absolute maximum allowable wear, demonstrating that the system will operate satisfactorily within these two limits, is to be submitted and approved.
- (d) For open loop systems the manufacturer is to submit information regarding the required standard of lubricating water filtration and lubricating water filters or separators are to be fitted which are able to achieve this requirement. The lubricating water supply is to be fitted with either continuous water sediment measuring equipment; turbidity monitoring equipment or an LR approved extractive sampling and testing procedure.
- (e) Where a closed cycle water system is used, arrangements are to allow analysis of the water for at least the following parameters:
 - (i) Chloride content.
 - (ii) Bearing material and metal particles content.

Water samples are to be representative of the water circulating within the sterntube.

- (f) The shaft is to either be constructed of corrosion resistant material or protected with a corrosion resistant protective liner or coating approved by LR. Where a protective liner or coating is used, this is to meet the requirements of *Pt 5, Ch 6, 3.9 Bronze or gunmetal liners on shafts* and a means of assessing the condition of this liner is to be submitted and approved.
- (g) Glands are to be capable of being replaced without withdrawal of the screwshaft.
- (h) There is to be a shaft starting/clutch engagement block to inhibit starting the shaft until lubricating water flow has been established. This is to only act as a starting block; for lubricating water flow alarm see *Table 6.4.1 Alarm and safeguard for water lubricated bearings*.
- (i) Alternative arrangements are subject to special consideration.

Table 6.4.1 Alarm and safeguard for water lubricated bearings

Item	Alarm	Note
Lubricating water flow	Low	See <i>Pt 5, Ch 6, 4.1 Screwshaft Condition Monitoring (SCM) 4.1.3</i>

Section

- 1 **Plans and particulars**
- 2 **Materials**
- 3 **Design**
- 4 **Fitting of propellers**
- 5 **Control and monitoring**

■ **Section 1**
Plans and particulars

1.1 Details to be submitted

1.1.1 A plan, in triplicate, of the propeller is to be submitted for approval, together with the following particulars using the symbols shown:

- (a) Maximum blade thickness of the expanded cylindrical section considered, T , in mm.
- (b) Maximum shaft power, see *Pt 5, Ch 1, 3.3 Power ratings*, P , in kW (H , in shp).
- (c) Estimated ship speed at design loaded draught in the free running condition at maximum shaft power and corresponding revolutions per minute, see *Pt 5, Ch 7, 1.1 Details to be submitted 1.1.1* and *Pt 5, Ch 7, 1.1 Details to be submitted 1.1.1*.
- (d) Revolutions per minute of the propeller at maximum power, R .
- (e) Propeller diameter, D , in metres.
- (f) Pitch at 25 per cent radius (for solid propellers only), $P_{0,25}$, in metres.
- (g) Pitch at 35 per cent radius (for controllable pitch propellers only), $P_{0,35}$, in metres.
- (h) Pitch at 60 per cent radius $P_{0,6}$, in metres.
- (i) Pitch at 70 per cent radius $P_{0,7}$, in metres.
- (j) Length of blade section of the expanded cylindrical section at 25 per cent radius (for solid propellers only), $L_{0,25}$, in mm.
- (k) Length of blade section of the expanded cylindrical section at 35 per cent radius (for controllable pitch propellers only) $L_{0,35}$, in mm.
- (l) Length of blade section of the expanded cylindrical section at 60 per cent radius, $L_{0,6}$, in mm.
- (m) Rake at blade tip measured at shaft axis (backward rake positive, forward rake negative), A , in mm.
- (n) Number of blades, N .
- (o) Developed area ratio, B .
- (p) Material: type and specified minimum tensile strength.
- (q) θ_s , skew angle, in degrees, see *Figure 7.1.1 Definition of skew angle*.
- (r) Connection of propeller to shaft — details of fit, push-up, securing, etc.

1.1.2 For propellers having a skew angle equal to or greater than 50° , in addition to the particulars detailed in *Pt 5, Ch 7, 1.1 Details to be submitted 1.1.1*, details are to be submitted of:

- (a) Full blade section details at each radial station defined for manufacture.
- (b) A detailed blade stress computation supported by the following hydrodynamic data for the ahead mean wake condition and when absorbing full power:
 - (i) Radial distribution of lift and drag coefficients, section inflow velocities and hydrodynamic pitch angles.
 - (ii) Section pressure distributions calculated by either an advised inviscid or viscous procedure.

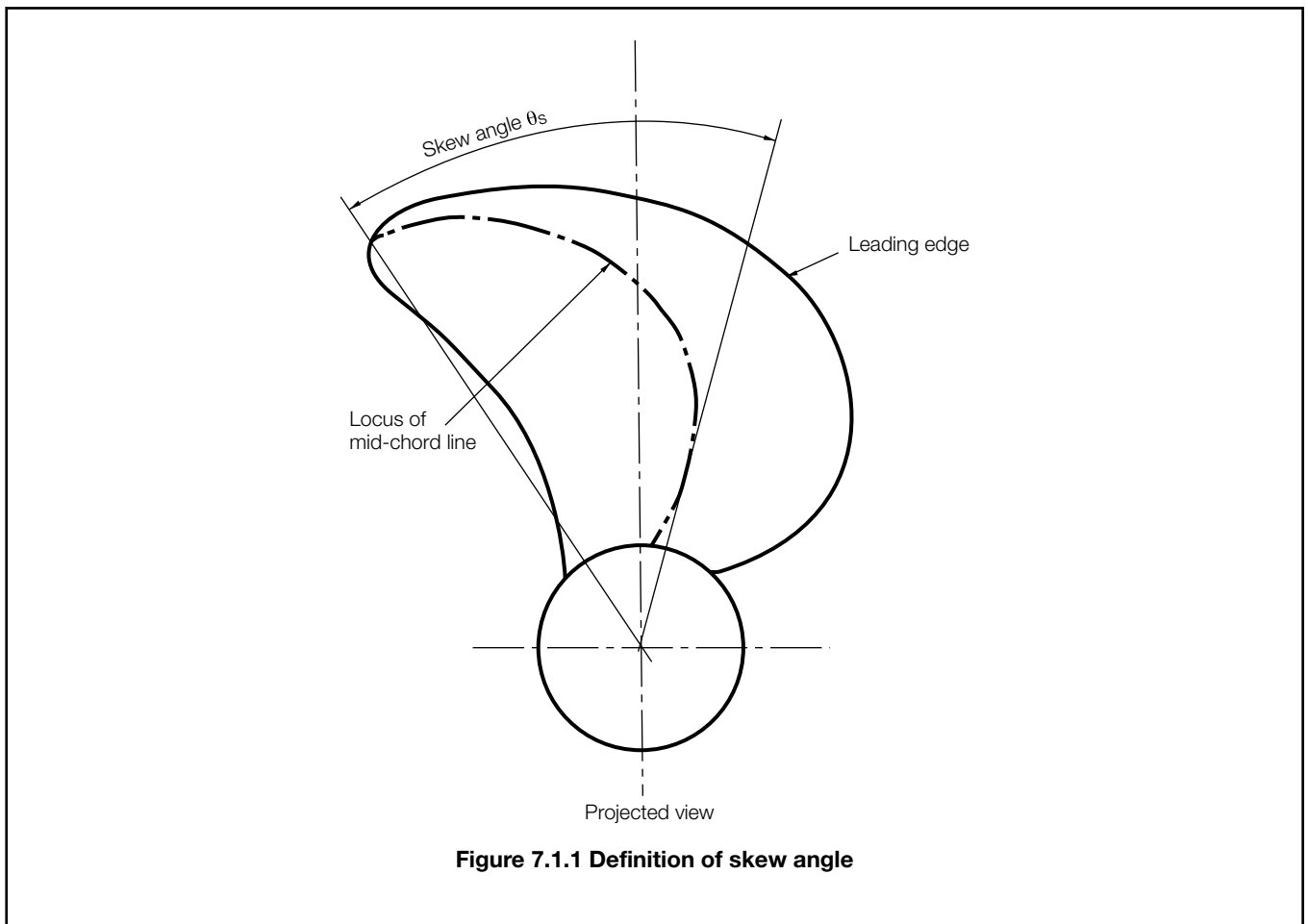

1.1.3 For blades of fixed pitch propellers with skew angle of 30° or greater, the stresses in the propeller blade during astern operation are not to exceed 80 per cent of the propeller blade material proof stress. Consideration is to be given to failure conditions and a factor of safety of 1,5 is to be attained using an acceptable fatigue failure criteria. Documentary evidence confirming that these criteria are satisfied is to be submitted.

1.1.4 The maximum skew angle of a propeller blade is defined as the angle, in projected view of the blade, between a line drawn through the blade tip and the shaft centreline and a second line through the shaft centreline which acts as a tangent to the locus of the mid-points of the helical blade sections, see *Figure 7.1.1 Definition of skew angle*.

1.1.5 Where propellers and similar devices of unusual design are intended for more than one operating regime, such as towing or trawling, then a detailed blade stress calculation for each operating condition, indicating the rotational and ship speed, is to be submitted for consideration.

1.1.6 Where it is proposed to fit the propeller to the screwshaft without the use of a key, plans of the boss, tapered end of screwshaft, propeller nut and, where applicable, the sleeve, are to be submitted.

1.1.7 Where a sleeve is fitted, details of the proposed type of material and mechanical properties are also to be submitted.

1.1.8 In cases where the ship has been the subject of model wake field tests, a copy of the results is to be submitted.

Section 2 Materials

2.1 Castings

2.1.1 Castings for propellers and propeller blades are to comply with the requirements of the *Rules for the Manufacture, Testing and Certification of Materials* (hereinafter referred to as the Rules for Materials). The specified minimum tensile strength is to be not less than stated in *Table 7.2.1 Materials for propellers*.

2.1.2 Where it is proposed to use materials which are not included in *Table 7.2.1 Materials for propellers*, details of the chemical composition, mechanical properties and density are to be submitted for approval.

Table 7.2.1 Materials for propellers

Material	SI Units			Metric Units		
	Specified minimum tensile strength	G Density	U Allowable stress	Specified minimum tensile strength	G Density	U Allowable stress
	N/mm ²	g/cm ³	N/mm ²	kgf/mm ²	g/cm ³	kgf/mm ²
Grey cast iron	250	7,2	17,2	25	7,2	1,75
Spheroidal or nodular graphite cast iron	400	7,3	20,6	41	7,3	2,1
Carbon steels	400	7,9	20,6	41	7,9	2,1
Low alloy steels	440	7,9	20,6	45	7,9	2,1
13% chromium stainless steels	540	7,7	41	55	7,7	4,2
Chromium-nickel austenitic stainless steel	450	7,9	41	46	7,9	4,2
Duplex stainless steels	590	7,8	41	60	7,8	4,2
Grade Cu 1 Manganese bronze (high tensile brass)	440	8,3	39	45	8,3	4,0
Grade Cu 2 Ni-Manganese bronze (high tensile brass)	440	8,3	39	45	8,3	4,0
Grade Cu 3 Ni-Aluminium bronze	590	7,6	56	60	7,6	5,7
Grade Cu 4 Mn-Aluminium bronze	630	7,5	46	64	7,5	4,7

2.1.3 Spheroidal cast iron load transmitting components of controllable pitch mechanisms, are to be manufactured, tested and certified in accordance with *Ch 7 Iron Castings* of the Rules for Materials and have an elongation of not less than 12 per cent.

■ Section 3
Design

3.1 Minimum blade thickness

3.1.1 For propellers having a skew angle of 25° or less, as defined in Pt 5, Ch 7, 1.1 Details to be submitted 1.1.4, the minimum blade thickness, T , of the propeller blades at 25 per cent radius for solid propellers, 35 per cent radius for controllable pitch propellers, neglecting any increase due to fillets, and at 60 per cent radius, is to be not less than:

$$T = \frac{KCA}{EFULN} + 100\sqrt{\frac{3150MP}{EFRULN}} \text{ mm}$$

$$\left(T = \frac{KCA}{9,81EFULN} + 27,4\sqrt{\frac{3150MH}{EFRULN}} \text{ mm} \right)$$

where

$$L = L_{0,25}, L_{0,35}, \text{ or } L_{0,6}, \text{ as appropriate}$$

$$K = \frac{GBD^3R^2}{675}$$

G = density, in g/cm³, see Table 7.2.1 Materials for propellers

U = allowable stress, in N/mm² (kgf/mm²) see Pt 5, Ch 7, 3.1 Minimum blade thickness 3.1.2, Pt 5, Ch 7, 3.1 Minimum blade thickness 3.1.3, Pt 5, Ch 7, 3.1 Minimum blade thickness 3.1.4, and Table 7.2.1 Materials for propellers

$$= E = \frac{\text{actual face modulus}}{0,09T^2L}$$

For aerofoil sections with and without trailing edge washback, E may be taken as 1,0 and 1,25 respectively

$$\left. \begin{array}{l} C = 1,0 \\ F = \frac{P_{0,25}}{D} + 0,8 \\ M = 1,0 + \frac{3,75D}{P_{0,7}} + 2,8\frac{P_{0,25}}{D} \end{array} \right\} \begin{array}{l} \text{for solid propellers at} \\ \text{25 per cent radius} \end{array}$$

$$\left. \begin{array}{l} C = 1,4 \\ F = \frac{P_{0,35}}{D} + 1,6 \\ M = 1,35 + \frac{5D}{P_{0,7}} + 2,6\frac{P_{0,35}}{D} \end{array} \right\} \begin{array}{l} \text{for controllable pitch} \\ \text{propellers at 35 per} \\ \text{cent radius} \end{array}$$

$$\left. \begin{array}{l} C = 1,6 \\ F = \frac{P_{0,6}}{D} + 4,5 \\ M = 1,35 + \frac{5D}{P_{0,7}} + 1,35\frac{P_{0,6}}{D} \end{array} \right\} \begin{array}{l} \text{for all propellers at 60} \\ \text{per cent radius} \end{array}$$

3.1.2 The fillet radius between the root of a blade and the boss of a propeller is to be not less than the Rule thickness of the blade or equivalent at this location. Composite radiused fillets or elliptical fillets which provide a greater effective radius to the blade are acceptable and are to be preferred. Where fillet radii of the required size cannot be provided, the value of

U is to be multiplied by $\left(\frac{r}{T}\right)^{0.2}$

where

r = proposed fillet radius at the root, in mm

T = Rule thickness of the blade at the root, in mm

Where a propeller has bolted-on blades, consideration is also to be given to the distribution of stress in the palms of the blades. In particular, the fillets of recessed bolt holes and the lands between bolt holes are not to induce stresses which exceed those permitted at the outer end of the fillet radius between the blade and the palm.

3.1.3 For propellers having skew angles of greater than 25°, but less than 50°, the mid-chord thickness, $T_{sk0,6}$, at the 60 per cent radius is to be not less than:

$$T_{sk0,6} = 0,54T_{0,6}\sqrt{1+0,1\theta_s} \text{ mm}$$

The mid-chord thickness, $T_{sk\text{root}}$, at 25 or 35 per cent radius, neglecting any increase due to fillets, is to be not less than:

$$T_{sk\text{root}} = 0,75T_{\text{root}}\sqrt[4]{1+0,1\theta_s} \text{ mm}$$

where

θ_s = proposed skew angle as defined in *Pt 5, Ch 7, 1.1 Details to be submitted 1.1.4*

$T_{0,6}$ = thickness at 60 per cent radius, calculated by *Pt 5, Ch 7, 3.1 Minimum blade thickness 3.1.1*, in mm

T_{root} = thickness at 25 per cent radius or 35 per cent radius, calculated by *Pt 5, Ch 7, 3.1 Minimum blade thickness 3.1.1*, in mm

The thicknesses at the remaining radii are to be joined by a fair curve and the sections are to be of suitable aerofoil section.

3.1.4 Results of detailed calculations where carried out, are to be submitted.

3.1.5 For cases where the composition of the propeller material is not specified in *Table 7.2.1 Materials for propellers*, or where propellers of the cast irons and carbon and low alloy steels shown in this Table are provided with an approved method of cathodic protection, special consideration will be given to the value of U .

3.1.6 The value U may be increased by 10 per cent for twin screw and outboard propellers of triple screw ships.

3.1.7 Where the design of a propeller has been based on analysis of reliable wake survey data in conjunction with a detailed fatigue analysis and is deemed to permit scantlings less than required by *Pt 5, Ch 7, 3.1 Minimum blade thickness 3.1.1* or *Pt 5, Ch 7, 3.1 Minimum blade thickness 3.1.3*, a detailed stress computation for the blades is to be submitted for consideration.

3.2 Keyless propellers

3.2.1 The symbols used in *Pt 5, Ch 7, 3.2 Keyless propellers 3.2.2* (oil injection method of fitting) and *Pt 5, Ch 7, 3.2 Keyless propellers 3.2.3* (dry fitting cast iron sleeve) are defined as follows:

d_1 = diameter of the screwshaft cone at the mid-length of the boss or sleeve, in mm

d_2 = outside diameter of the sleeve at its mid-length, in mm

d_3 = outside diameter of the boss at its mid-length, in mm

d_i = bore diameter of screwshaft, in mm

$$h = \frac{2}{E_2} \left(\frac{1}{k_1^2 - 1} \right)$$

$$k_1 = \frac{d_2}{d_1}$$

$$k_2 = \frac{d_3}{d_2}$$

$$k_3 = \frac{d_3}{d_1}$$

$$l = \frac{d_i}{d_1}$$

$$p_1 = \frac{2M}{A_1 \theta_1 V_1} \left(-1 + \sqrt{1 + V_1 \left(\frac{F_1^2}{M^2} + 1 \right)} \right)$$

$$p_2 = \frac{2M}{A_2 \theta_2 V_2} \left(-1 + \sqrt{1 + V_2 \left(\frac{F_2^2}{M^2} + 1 \right)} \right)$$

$$p_{10} = \frac{2M}{A_1 \theta_1 V_1} \left(-1 + \sqrt{1 + V_1 \left(\frac{F_{10}^2}{M^2} + 1 \right)} \right)$$

$$p_{20} = \frac{2M}{A_2 \theta_2 V_2} \left(-1 + \sqrt{1 + V_2 \left(\frac{F_{20}^2}{M^2} + 1 \right)} \right)$$

A_1 = contact area of fitting at screwshaft, in mm²

A_2 = contact area of fitting at outside of sleeve, in mm²

$$B_1 = \frac{1}{E_2} \left(\frac{k_1^2 + 1}{k_1^2 - 1} + \nu_2 \right) + \frac{1}{E_1} \left(\frac{1 + l^2}{1 - l^2} - \nu_1 \right)$$

$$B_2 = \frac{1}{E_3} \left(\frac{k_2^2 + 1}{k_2^2 - 1} + \nu_3 \right) + \frac{1}{E_2} \left(\frac{k_1^2 + 1}{k_1^2 - 1} - \nu_2 \right)$$

$$B_3 = \frac{1}{E_3} \left(\frac{k_3^2 + 1}{k_3^2 - 1} + \nu_3 \right) + \frac{1}{E_1} \left(\frac{1 + l^2}{1 - l^2} - \nu_1 \right)$$

C = 0 for turbine installations

= $\frac{\text{vibratory torque at the maximum service speed}}{\text{mean torque at the maximum service speed}}$

for oil engine installations

E_1 = modulus of elasticity of screwshaft material, in N/mm² (kgf/mm²)

E_2 = modulus of elasticity of sleeve material, in N/mm² (kgf/mm²)

E_3 = modulus of elasticity of propeller material, in N/mm² (kgf/mm²)

$$F_1 = \frac{2Q}{d_1}(1 + C)$$

$$F_2 = \frac{2Q}{d_2}(1 + C)$$

$$F_{10} = \frac{2Q}{d_1} \left(1 + C + \frac{I_f}{100} \right)$$

$$F_{20} = \frac{2Q}{d_2} \left(1 + C + \frac{I_f}{100} \right)$$

I_f = percentage increase for Ice Class 1D and 1E, obtained from *Table 2.5.1 Increase for main engine shafting and propellers* in Pt 8, Ch 2,5

M = propeller thrust, in N (kgf)

Q = mean torque corresponding to P (H) and R as defined in *Pt 5, Ch 1, 3.3 Power ratings*, in N mm (kgf mm)

T_1 = temperature at time of fitting propeller on shaft, in °C

T_2 = temperature at time of fitting sleeve into boss, in °C

$$V_1 = 0,51 \left(\frac{\mu_1}{\theta_1} \right)^2 - 1$$

$$V_2 = 0,51 \left(\frac{\mu_2}{\theta_2} \right)^2 - 1$$

$$Y = B_1 B_2 - h^2 k_1^2$$

α_1 = coefficient of linear expansion of screwshaft material, in mm/mm/°C

α_2 = coefficient of linear expansion of sleeve material, in mm/mm/°C

α_3 = coefficient of linear expansion of propeller material, in mm/mm/°C

θ_1 = taper of the screwshaft cone, but is not to exceed $\frac{1}{15}$ on the diameter, i.e. $\theta_1 \leq \left(\frac{1}{15} \right)$

θ_2 = taper of the outside of the sleeve

μ_1 = coefficient of friction for fitting of boss assembly on shaft

= 0,13 for oil injection method of fitting

μ_2 = coefficient of friction for fitting sleeve into the boss

ν_1 = Poisson's ratio for screwshaft material

ν_2 = Poisson's ratio for sleeve material

ν_3 = Poisson's ratio for propeller material

Consistent sets of units are to be used in all formulae.

3.2.2 Where it is proposed to fit a keyless propeller by the oil shrink method, the pull-up, δ on the screwshaft is to be not less than:

$$\delta_T = \frac{d_1}{\theta_1} (p_1 B_3 + (\alpha_3 - \alpha_1)(35 - T_1)) \text{ mm}$$

or, where Ice Class notation is required, the greater of δ_T or δ_O , where

$$\delta_O = \frac{d_1}{\theta_1} (p_{10} B_3 - (\alpha_3 - \alpha_1) T_1) \text{ mm}$$

The yield stress or 0,2 per cent proof stress, σ_o of the propeller material is to be not less than:

$$\sigma_o = \frac{1,4}{B_3} \left(\frac{\theta_1 \delta_p}{d_1} + T_1 (\alpha_3 - \alpha_1) \right) \frac{\sqrt{3k_3^4 + 1}}{k_3^2 - 1} \text{ N/mm}^2 \text{ (kgf/mm}^2\text{)}$$

where

δ_p = proposed pull-up at the fitting temperature

The start point load, W , to determine the actual pull-up is to be not less than:

$$W = A_1 \left(0,002 + \frac{\theta_1}{20} \right) \left(p_1 + \frac{18}{B_3} (\alpha_3 - \alpha_1) \right) \text{ N(kgf)}$$

3.2.3 Where a cast iron sleeve is first fitted to the bore of the propeller boss by an interference fit, the push-up load of the sleeve into the boss, W_2 , is to be not less than:

$$W_{2T} = \frac{A_2}{B_2} \left(\mu_2 + \frac{\theta_2}{2} \right) (B_2 p_2 - h p_1 + (\alpha_3 - \alpha_2) (35 - T_2)) \text{ N(kgf)}$$

or, where Ice Class notation is required, the greater of W_{2T} or W_{20}

where

$$W_{20} = \frac{A_2}{B_2} \left(\mu_2 + \frac{\theta_2}{2} \right) (B_2 p_{20} - h p_{10} - (\alpha_3 - \alpha_2) T_2) \text{ N(kgf)}$$

The pull-up of the sleeve in the boss at the fitting temperature is to be in accordance with the following formula:

$$\delta_2 = \frac{W_2 B_2 d_2}{A_2 \left(\mu_2 + \frac{\theta_2}{2} \right) \theta_2} \text{ mm}$$

The push-up load, W_1 , of the combined boss and sleeve on a steel screwshaft is to be not less than:

$$W_{1T} = A_1 \left(\mu_1 + \frac{\theta_1}{2} \right) \left(p_1 + \frac{h k_1^2}{Y} (\alpha_3 - \alpha_2) (35 - T_1) \right) \text{ N(kgf)}$$

or where Ice Class notation is required, the greater of W_{1T} or W_{10} where

$$W_{10} = A_1 \left(\mu_1 + \frac{\theta_1}{2} \right) \left(p_{10} - \frac{h k_1^2}{Y} (\alpha_3 - \alpha_2) T_1 \right) \text{ N(kgf)}$$

The push-up distance of the combined boss and sleeve on a steel screwshaft is to be in accordance with the following formula:

$$\delta_1 = \frac{W_1 d_1 Y}{A_1 B_2 \theta_1 \left(\mu_1 + \frac{\theta_1}{2} \right)} \text{ mm}$$

3.2.4 Where a cast iron sleeve is fitted into the boss by means of Araldite, the conditions are to satisfy those of Pt 5, Ch 7, 3.2 *Keyless propellers* 3.2.3 except that the value of W_2 is to be taken as equivalent to:

$$W_2 = A_2 \left(0,25 + \frac{\theta_2}{2} \right) \left(p_A + \frac{(\alpha_3 - \alpha_2) (18 - T_2)}{B_2} \right) \text{ N(kgf)}$$

where

$$p_A = 3,5 \text{ N/mm}^2$$

$$(p_A = 0,35 \text{ kgf/mm}^2)$$

3.2.5 For the triple element keyless propeller, the yield stress or 0,2 per cent proof stress of the propeller material, σ_o is to be not less than:

$$\sigma_o = 1,4p_3 \frac{\sqrt{3k_2^4 + 1}}{k_2^2 - 1} \text{ N/mm}^2 (\text{kgf/mm}^2)$$

where

$$p_3 = \frac{W_1 h}{A_1 B_2 \left(\mu_1 + \frac{\theta_1}{2} \right)} + \frac{W_2}{A_2 \left(\mu_2 + \frac{\theta_2}{2} \right)} + \frac{\alpha_3 - \alpha_2}{B_2} \left(T_2 + \frac{h^2 k_1^2}{Y} T_1 \right)$$

3.2.6 Where the sleeve is manufactured of material having an elongation in excess of five per cent, the yield point or 0,2 per cent proof stress of the sleeve material, σ_o is to be not less than:

$$\sigma_o = \frac{1,6}{k_1^2 - 1} \sqrt{3k_1^4 (p_3 - p_5)^2 + (p_3 k_1^2 - p_5)^2} \text{ N/mm}^2 (\text{kgf/mm}^2)$$

or

$$\sigma_o = \frac{1,6}{k_1^2 - 1} \sqrt{3k_1^4 (p_4 - p_6)^2 + (p_4 k_1^2 - p_6)^2} \text{ N/mm}^2 (\text{kgf/mm}^2)$$

where

$$p_4 = p_3 - \frac{35B_1}{Y} (\alpha_3 - \alpha_2)$$

$$p_5 = \frac{W_1}{A_1 \left(\mu_1 + \frac{\theta_1}{2} \right)} + \frac{h k_1^2}{Y} (\alpha_3 - \alpha_2) T_1$$

$$p_6 = p_5 - \frac{35h k_1^2}{Y} (\alpha_3 - \alpha_2)$$

3.2.7 Where the sleeve is manufactured of material having an elongation not more than five per cent, the minimum specified ultimate tensile strength σ_u , based on the ruling section, is to be not less than:

$$\sigma_u = \frac{2,4}{k_1^2 - 1} \left(p_5 \left(\frac{5k_1^2 + 3}{4} \right) - 2p_3 k_1^2 \right) \text{ N/mm}^2 (\text{kgf/mm}^2)$$

or

$$\sigma_u = \frac{2,4}{k_1^2 - 1} \left(p_6 \left(\frac{5k_1^2 + 3}{4} \right) - 2p_4 k_1^2 \right) \text{ N/mm}^2 (\text{kgf/mm}^2)$$

3.2.8 Where it is proposed to use a sleeve manufactured from a material other than cast iron, full details are to be submitted for consideration.

■ *Section 4* **Fitting of propellers**

4.1 Propeller boss

4.1.1 The propeller boss is to be a good fit on the screwshaft cone. The forward edge of the bore of the propeller boss is to be rounded to about a 6 mm radius. In the case of keyed propellers, the length of the forward fitting surface is to be about one diameter and where the fitting is by means of a hydraulic nut, the requirements of *Pt 5, Ch 7, 4.2 Shop tests of keyless propellers* and *Pt 5, Ch 7, 4.3 Final fitting of keyless propellers* where appropriate, are applicable.

4.2 Shop tests of keyless propellers

4.2.1 The bedding of the propeller, or the sleeve where applicable with the shaft is to be demonstrated in the shop to the satisfaction of the Surveyors. Sufficient time is to be allowed for the temperature of the components to equalise before bedding. Alternative means for demonstrating the bedding of the propeller will be considered.

4.2.2 Means are to be provided to indicate the relative axial position of the propeller boss on the shaft taper.

4.3 Final fitting of keyless propellers

4.3.1 After verifying that the propeller and shaft are at the same temperature and the mating surfaces are clean and free from oil or grease, the propeller is to be fitted on the shaft to the satisfaction of the Surveyors. The propeller nut is to be securely locked to the shaft.

4.3.2 Permanent reference marks are to be made on the propeller boss, nut and shaft to indicate angular and axial positioning of the propeller. Care is to be taken in marking the inboard end of the shaft taper to minimise stress raising effects.

4.3.3 The outside of the propeller boss is to be hard stamped with the following details:

- (a) For the oil injection method of fitting, the start point load and the axial pull-up at 0°C and 35°C.
- (b) For the dry fitting method, the push-up load at 0°C and 35°C.

4.3.4 A copy of the fitting curve relative to temperature and means for determining any subsequent movement are to be placed on board.

■ *Section 5* **Control and monitoring**

5.1 General

5.1.1 Control engineering systems are to be in accordance with the requirements of *Pt 6, Ch 1 Control Engineering Systems*.

5.2 Unattended machinery

5.2.1 Where controllable pitch propellers are fitted with automatic or remote controls so that under normal operating conditions they do not require any manual intervention by the operators, they are to be provided with the alarms and safety arrangements required by *Pt 5, Ch 7, 5.2 Unattended machinery* to *Pt 5, Ch 7, 5.3 Controllable pitch propellers and transverse thrust units*, as appropriate. Alternative arrangements which provide equivalent safeguards will be considered.

5.2.2 Where machinery specified in this Section is required to be provided with a standby pump, the standby pump is to start automatically if the discharge pressure from the working pumps falls below a predetermined value.

5.3 Controllable pitch propellers and transverse thrust units

5.3.1 Alarms and safeguards are indicated in *Pt 5, Ch 7, 5.3 Controllable pitch propellers and transverse thrust units 5.3.2 to Pt 5, Ch 7, 5.3 Controllable pitch propellers and transverse thrust units 5.3.5* and *Table 7.5.1 Controllable pitch propellers and transverse thrust units: Alarms and safeguards*. For azimuth thrusters, see also *Pt 5, Ch 20 Azimuth Thrusters*.

Table 7.5.1 Controllable pitch propellers and transverse thrust units: Alarms and safeguards

Item	Alarm	Note
Hydraulic system pressure	Low	—
Hydraulic oil supply tank level	Low	—
Hydraulic oil temperature	High	Where an oil cooler is fitted
Power supply to the control system between the remote control station and hydraulic actuator	Failure	See <i>Pt 6, Ch 1, 2.5 Control systems, general requirements 2.5.2</i>

5.3.2 For controllable pitch propellers for main propulsion, a standby or alternative power source of actuating medium for controlling the pitch of the propelling blades is to be provided. Automatic start of the standby pump supplying hydraulic power for pitch control is to be provided.

5.3.3 Controllable pitch propellers for main propulsion are to be provided with indications of shaft speed, direction and magnitude of thrust and propeller pitch as a measure of the propeller blade or actuator movement at each station from which it is possible to control shaft speed or propeller pitch.

5.3.4 Where transverse thrust units are remotely controlled, means are to be provided at the remote control station to stop the propulsion unit.

5.3.5 Transverse thrust units are to be provided with indications of direction and magnitude of thrust and propeller pitch at each station from which it is possible to control the propeller pitch.

*Section***Scope**

- 1 **General**
 - 2 **Torsional vibration**
 - 3 **Axial vibration**
 - 4 **Lateral vibration**
 - 5 **Shaft alignment**
-

■ **Scope**

The requirements of this Chapter are applicable to the following systems:

- (a) Main propulsion systems formed by oil engines, turbines or electric motors, directly driven or geared to the shafting.
- (b) Machinery driven at constant speed by oil engines, developing 110 kW and over, for essential auxiliary services including generator sets which are the source of power for main electric propulsion motors.

Unless otherwise advised, it is the responsibility of the Shipbuilder as main contractor to ensure, in co-operation with the Enginebuilders, that the information required by this Chapter is prepared and submitted.

■ *Section 1*
General

1.1 Basic requirements

1.1.1 The systems are to be free from excessive torsional, axial, lateral and linear vibration, and are to be aligned in accordance with accepted tolerances and taking into account the requirements of *Pt 5, Ch 8, 5.5 Measurements*.

1.1.2 System designs are to take account of the potential effects of engine and component malfunction and variability in characteristic values such as stiffness and damping of flexible couplings and dampers or engine misfire conditions.

1.1.3 Where torques, stresses or amplitudes are found to exceed the limits for continuous operation, restrictions in speed and/or power will be imposed.

1.1.4 Where significant changes are subsequently made to a dynamic system which has been approved, (e.g. by changing the original design parameters of the prime movers and/or propulsion shafting system, or by fitting a propeller or flexible coupling of different design from the previous), revised calculations may require to be submitted for consideration. Details of all such changes are to be submitted.

1.2 Resilient mountings

1.2.1 For resilient mountings, see *Pt 5, Ch 1, 4.3 Resilient mountings*.

1.3 Flexible couplings

1.3.1 Where the shafting system incorporates flexible couplings, the effects of such couplings on the various modes of vibration are to be considered, see *Pt 5, Ch 8, 2 Torsional vibration, Pt 5, Ch 8, 3 Axial vibration and Pt 5, Ch 8, 4 Lateral vibration*.

■ Section 2**Torsional vibration****2.1 General**

2.1.1 In addition to the shafting complying with the requirements of *Pt 5, Ch 1 General Requirements for the Design and Construction of Machinery* to *Pt 5, Ch 7 Propellers* and *Pt 5, Ch 20 Azimuth Thrusters* (where applicable), approval is also dependent on the torsional vibration characteristics of the complete shafting system(s) being found satisfactory.

2.1.2 Further to the Scope of this Chapter, the requirements of this Section are applicable:

- (a) to ships that are required to comply with the *SOLAS - International Convention for the Safety of Life at Sea*, as amended, (SOLAS); and
- (b) for all other ships where any one main engine has a power output exceeding 500 kW.

2.2 Particulars to be submitted

2.2.1 Torsional vibration calculations, showing the mass elastic values, associated natural frequencies and an analysis of the vibratory torques and stresses for the full dynamic system.

2.2.2 Particulars of the division of power and utilisation, throughout the speed range, for turbines, multi-engine or other combined power installations, and those with power take-off systems. For multi-engined installations, special considerations associated with the possible variations in the mode of operation and phasing of engines.

2.2.3 Enginebuilder's harmonic torque data used in the torsional vibration calculations, see *Pt 5, Ch 8, 2.3 Scope of calculations 2.3.3*.

2.2.4 Details of operating conditions encountered in service for prolonged periods, e.g. idling speed, range of trawling revolutions per minute, combinator characteristics for installations equipped with controllable pitch propellers.

2.2.5 Details, obtained from the manufacturers, of the principal characteristics of machinery components such as dampers and couplings, confirming their capability to withstand the effects of vibratory loading including, where appropriate, heat dissipation. Evidence that the data which is used to represent the characteristics of components, which has been quoted from other sources, is supported by a programme of physical measurement and control.

2.2.6 Where installations include electric motors, generators or non-integral pumps, drawings showing the principal dimensions of the shaft, together with manufacturer's estimates of mass moment of inertia for the rotating parts.

2.2.7 Details of vibration or performance monitoring proposals where required.

2.3 Scope of calculations

2.3.1 Calculations are to be carried out, by recognised techniques, for the full dynamic system formed by the oil engines, turbines, motors, generators, flexible couplings, gearing, shafting and propeller, where applicable, including all branches.

2.3.2 Calculations are to give due consideration to the potential deviation in values used to represent component characteristics due to manufacturing/service variability.

2.3.3 The calculations carried out on oil engine systems are to be based on the Enginebuilders' harmonic torque data. The calculations are to take account of the effects of engine malfunctions commonly experienced in service, such as a cylinder not firing (i.e. no injection but with compression) giving rise to the highest torsional vibration stresses in the shafting. Calculations are also to take account of a degree of imbalance between cylinders, which is characteristic of the normal operation of an engine under service conditions.

2.3.4 Whilst limits for torsional vibration stress in crankshafts are no longer stated explicitly, calculations are to include estimates of crankshaft stress at all designated operating/service speeds, as well as at any major critical speed.

2.3.5 Calculations are to take into account the possible effects of excitation from propeller rotation. Where the system shows some sensitivity to this phenomenon, propeller excitation data for the installation should be used as a basis for calculation, and submitted.

2.3.6 Where the torsional stiffness of flexible couplings varies with torque, frequency or speed, calculations should be representative of the appropriate range of effective dynamic stiffness.

2.4 Symbols and definitions

2.4.1 The symbols used in this Section are defined as follows:

d = minimum diameter of shaft considered, in mm

d_i = diameter of internal bore, in mm

k = the factor used in determining minimum shaft diameter, defined in *Pt 5, Ch 6, 3.1 Intermediate shafts 3.1.1* and *Pt 5, Ch 6, 3.5 Screwshafts and tube shafts 3.5.1*

r = ratio N/N_s or N_c/N_s whichever is applicable

C_d = a size factor defined as $0,35 + 0,93d^{-0,2}$

C_k = a factor for different shaft design features, see *Table 8.2.1 Ck factors*

N = engine speed, in rev/min

N_c = critical speed, in rev/min

N_s = maximum continuous engine speed, in rev/min, or, in the case of constant speed generating sets, the full load speed, in rev/min

Q_s = rated full load mean torque

σ_u = specified minimum tensile strength of the shaft material, in N/mm²

τ_c = permissible stress due to torsional vibrations for continuous operation, in N/mm²

τ_t = permissible stress due to torsional vibrations for transient operation, in N/mm²

e = slot width, in mm

l = slot length, in mm.

2.4.2 Alternating torsional vibration stresses are to be based on half-range amplitudes of stress resulting from the alternating torque (which is superimposed on the mean torque) representing the synthesis of all harmonic orders present.

Table 8.2.1 C_k factors

Intermediate shafts with	
Integral coupling flange and straight sections	1,0
Shrink fit coupling	1,0
Keyway, tapered connection	0,60
Keyway, cylindrical connection	0,45
Radial hole	0,50
Longitudinal slot	0,30 (see <i>Pt 5, Ch 8, 2.4 Symbols and definitions 2.4.4</i>)
Thrust shafts external to engines	
On both sides of thrust collar	0,85
In way of axial bearing where a roller bearing is used as a thrust bearing	0,85
Propeller shafts	

Flange mounted or keyless taper fitted propellers	0,55
Key fitted propellers	0,55
Between forward end of aft most bearing and forward stern tube seal	0,80

Note The determination of C_k – factors for shafts other than shown in this Table will be specially considered by LR.

2.4.3 All vibration stress limits relate to the synthesis or measurement of total nominal torsional stress and are to be based on the plain section of the shafting neglecting stress raisers.

2.4.4 For a longitudinal slot $C_k = 0,3$ is applicable within the dimension limitations given in *Pt 5, Ch 6, 3.1 Intermediate shafts 3.1.6*. If the slot dimensions are outside these limitations, or if the use of another C_k is desired, the actual stress concentration factor (*scf*) is to be documented or determined from *Pt 5, Ch 8, 2.4 Symbols and definitions 2.4.5* or by direct application of FE calculation, in which case:

$$C_k = \frac{1,45}{scf}$$

Note that the *scf* is defined as the ratio between the maximum local principal stress and $\sqrt{3}$ times the nominal torsional stress (determined for the bored shaft without slots).

2.4.5 **Stress concentration factor of slots.** The stress concentration factor (*scf*) at the ends of slots can be determined by means of the following empirical formulae:

$$scf = \alpha_{t(hole)} + 0,8 \frac{\frac{(l-e)}{d}}{\sqrt{\left(1 - \frac{d_i}{d}\right) \frac{e}{d}}}$$

This formula applies to:

- Slots at 120 or 180 or 360 degrees apart.
- Slots with semicircular ends. A multi-radii slot end can reduce the local stresses, but this is not included in this empirical formula.
- Slots with no edge rounding (except chamfering), as any edge rounding increases the *scf* slightly.

$\alpha_{t(hole)}$ represents the stress concentration of radial holes and can be determined as :

$$\alpha_{t(hole)} = 2,3 - 3\frac{e}{d} + 15\left(\frac{e}{d}\right)^2 + 10\left(\frac{e}{d}\right)^2\left(\frac{d_i}{d}\right)^2$$

where, in this context, e = hole diameter, in mm (this is independent of slot width)

or simplified to $\alpha_{t(hole)} = 2,3$.

2.5 Limiting stress in propulsion shafting

2.5.1 The following stress limits apply to intermediate shafts, thrust shafts and to screwshafts fully protected from sea water. For screwshafts, the limits apply to the minimum sections of the portions of the screwshaft as defined in *Pt 5, Ch 6, 3.5 Screwshafts and tube shafts*.

2.5.2 In the case of unprotected screwshafts, special consideration will be given.

2.5.3 In no part of the propulsion shafting system may the alternating torsional vibration stresses exceed the values of τ_c for continuous operation, and τ_t for transient running, given by the following formulae:

For $r < 0,9$:

$$\tau_c = \frac{\sigma_u + 160}{18} C_k C_d (3 - 2r^2) \text{ N/mm}^2$$

and where $r < 0,8$

$$\tau_t = \pm 1,7 \tau_c \frac{1}{\sqrt{C_k}} \text{ N/mm}^2$$

For $0,9 \leq r \leq 1,05$:

$$\tau_c = \frac{\sigma_u + 160}{18} C_k C_d 1,38 \text{ N/mm}^2$$

2.5.4 In general, the tensile strength of the steel used is to comply with the requirements of *Pt 5, Ch 6, 2 Materials*. For the calculation of the permissible limits of stresses due to torsional vibration, σ_u is not to be taken as more than 800 N/mm² in the case of alloy steel intermediate shafts, or 600 N/mm² in the case of carbon and carbon-manganese steel intermediate, thrust and propeller shafts.

2.5.5 Where the scantlings of coupling bolts and straight shafting differ from the minimum required by the Rules, special consideration will be given.

2.6 Generator sets

2.6.1 Natural frequencies of the complete set are to be sufficiently removed from the firing impulse frequency at the full load speed, particularly where flexible couplings are interposed between the engine and generator.

2.6.2 Within the speed limits of $0,95N_s$ and $1,05N_s$ the vibration stresses in the transmission shafting are not to exceed the values given by the following formula:

$$\tau_c = \pm (21 - 0,014d) \text{ N/mm}^2.$$

2.6.3 Vibration stresses in the transmission shafting due to critical speeds which have to be passed through in starting and stopping, are not to exceed the values given by the following formula:

$$\tau_t = 5,5\tau_c.$$

2.6.4 The amplitudes of the total vibratory inertia torques imposed on the generator rotors are to be limited to $\pm 2,0Q_s$ in general, or to $\pm 2,5Q_s$ for close-coupled revolving field alternating current generators, over the speed range from $0,95N_s$ to $1,05N_s$. Below $0,95N_s$ the amplitudes are to be limited to $\pm 6,0Q_s$. Where two or more generators are driven from one engine, each generator is to be considered separately in relation to its own rated torque.

2.6.5 The rotor shaft and structure are to be designed to withstand these magnitudes of vibratory torque. Where it can be shown that they are capable of withstanding a higher vibratory torque, special consideration will be given.

2.6.6 In addition to withstanding the vibratory conditions over the speed range from $0,95N_s$ to $1,05N_s$, flexible couplings, if fitted, are to be capable of withstanding the vibratory torques and twists arising from transient criticals and short-circuit currents.

2.6.7 In the case of alternating current generators, resultant vibratory amplitudes at the rotor are not to exceed $\pm 3,5$ electrical degrees under both full load working conditions and the malfunction condition mentioned in *Pt 5, Ch 8, 2.3 Scope of calculations 2.3.3*.

2.7 Other auxiliary machinery systems

2.7.1 The relevant requirements of *Pt 5, Ch 8, 2.6 Generator sets 2.6.1*, *Pt 5, Ch 8, 2.6 Generator sets 2.6.2* and *Pt 5, Ch 8, 2.6 Generator sets 2.6.3* are also applicable to other machinery installations such as pumps or compressors with the speed limits being taken as $0,95N_s$ to $1,10N_s$.

2.8 Other machinery components

2.8.1 **Torsional vibration dampers.** The use of dampers or detuners to limit vibratory stress due to resonances which occur within the range between $0,85N_s$ and $1,05N_s$ are to be considered. If fitted, these should be of a type which makes adequate provision for dissipation of heat. Where necessary, performance monitoring may be required.

2.8.2 Flexible couplings:

- (a) Flexible couplings included in an installation are to be capable of transmitting the mean and vibratory loads without exceeding the makers' recommended limits for angular amplitude or heat dissipation.
- (b) Where calculations indicate that the limits recommended by the manufacturer may be exceeded under misfiring conditions, a suitable means is to be provided for detecting and indicating misfiring. Under these circumstances power and/or speed restrictions may be required. Where machinery is non-essential, disconnection of the branch containing the coupling would be an acceptable action in the event of misfiring.

2.8.3 Gearing:

- (a) The torsional vibration characteristics are to comply with the requirements of *Pt 5, Ch 8, 2.3 Scope of calculations*. The sum of the mean and of the vibratory torque should not exceed four-thirds of the full transmission torque, at MCR, throughout the speed range. In cases where the proposed transmission torque loading on the gear teeth is less than the maximum allowable, special consideration will be given to the acceptance of additional vibratory loading on the gears.
- (b) Where calculations indicate the possibility of torque reversal, the operating speed range is to be determined on the basis of observations during sea trials.

2.9 Measurements

2.9.1 Where calculations indicate that the limits for torsional vibration within the range of working speeds are exceeded, measurements, using an appropriate technique, may be taken from the machinery installation for the purpose of approval of torsional vibration characteristics, or determining the need for restricted speed ranges, and the confirmation of their limits.

2.9.2 Where differences between calculated and measured levels of stress, torque or angular amplitude arise, the stress limits are to be applied to the stresses measured on the completed installation.

2.9.3 The method of measurement is to be appropriate to the machinery components and the parameters which are of concern. Where shaft stresses have been estimated from angular amplitude measurements, and are found to be close to limiting stresses as defined in *Pt 5, Ch 8, 2.5 Limiting stress in propulsion shafting*, strain gauge techniques may be required. When measurements are required, detailed proposals are to be submitted.

2.10 Vibration monitoring

2.10.1 Where calculations and/or measurements have indicated the possibility of excessive vibratory stresses, torques or angular amplitudes in the event of a malfunction, vibration or performance monitoring, directly or indirectly, may be required.

2.11 Restricted speed and/or power ranges

2.11.1 Restricted speed and/or power ranges will be imposed to cover all speeds where the stresses exceed the limiting values, τ_c , for continuous running, including one cylinder misfiring conditions if intended to be continuously operated under such conditions. For controllable pitch propellers with the possibility of individual pitch and speed control, both full and zero pitch conditions are to be considered. Similar restrictions will be imposed, or other protective measures required to be taken, where vibratory torques or amplitudes are considered to be excessive for particular machinery items. At each end of the restricted speed range the engine is to be stable in operation.

2.11.2 The restricted speed range is to take account of the tachometer speed tolerances at the barred speeds.

2.11.3 Critical responses which give rise to speed restrictions are to be arranged sufficiently removed from the maximum revolutions per minute to ensure that, in general, at $r = 0,8$ the stress due to the upper flank does not exceed τ_c .

2.11.4 Provided that the stress amplitudes due to a torsional critical response at the borders of the barred speed range are less than τ_c under normal and stable operating conditions the speed restriction derived from the following formula may be applied:

$$\frac{16}{18-r}N_c \text{ to } \frac{18-r}{16}N_c \text{ inclusive.}$$

2.11.5 Where calculated vibration stresses due to criticals below $0,8N_s$ marginally exceed τ_c or where the critical speeds are sharply tuned, the range of revolutions restricted for continuous operation may be reduced.

2.11.6 In cases where the resonance curve of a critical speed has been derived from measurements, the range of revolutions to be avoided for continuous running may be taken as that over which the measured vibration stresses are in excess of τ_c , having regard to the tachometer accuracy.

2.11.7 Where restricted speed ranges under normal operating conditions are imposed, notice boards are to be fitted at the control stations stating that the engine is not to be run continuously between the speed limits obtained as above, and the engine tachometers are to be marked accordingly.

2.11.8 Where vibration stresses approach the limiting value τ , the range of revolutions restricted for continuous operation may be extended. The notice boards are to indicate that this range must be passed through rapidly.

2.11.9 For excessive vibratory torque, stress or amplitude in other components, based on *Pt 5, Ch 8, 2.8 Other machinery components 2.8.1 to Pt 5, Ch 8, 2.8 Other machinery components 2.8.3*, the limits of any speed/power restriction are to be such as to maintain acceptable levels during continuous operation.

2.11.10 Where the restrictions are imposed for the contingency of an engine malfunction or component failure, the limits are to be entered in the machinery Operating Manual.

2.11.11 Restricted speed ranges in one-cylinder misfiring conditions on ships with single engine propulsion are to enable safe navigation whereby sufficient propulsion power is available to maintain control of the ship.

2.11.12 There are to be no restricted speed ranges imposed above a speed ratio of $r = 0,8$ under normal operating conditions.

2.12 Tachometer accuracy

2.12.1 Where restricted speed ranges are imposed as a condition of approval, the tachometer accuracy is to be checked against the counter readings, or by equivalent means, in the presence of the Surveyors to verify that it reads correctly within ± 2 per cent in way of the restricted range of revolutions.

2.13 Governor control

2.13.1 Where there is a significant critical response above and close to the maximum service speed, consideration is to be given to the effect of temporary overspeed.

■ *Section 3* **Axial vibration**

3.1 General

3.1.1 For all main propulsion shafting systems, the Shipbuilders are to ensure that axial vibration amplitudes are satisfactory throughout the speed range. Where natural frequency calculations indicate significant axial vibration responses, sufficiently wide restricted speed ranges will be imposed. Alternatively, measurements may be used to determine the speed ranges at which amplitudes are excessive for continuous running.

3.2 Particulars to be submitted

3.2.1 The results of calculations, together with recommendations for any speed restrictions found necessary.

3.2.2 Enginebuilder's recommendation for axial vibration amplitude limits at the non-driving end of the crankshaft or at the thrust collar.

3.2.3 Estimate of flexibility of the thrust bearing and its supporting structure.

3.2.4 The requirement for calculations to be submitted may be waived upon request provided evidence of satisfactory service experience of similar dynamic installations is submitted.

3.3 Calculations

3.3.1 Calculations of axial vibration natural frequency are to be carried out using appropriate techniques, taking into account the effects of flexibility of the thrust bearing, for shaft systems where the propeller is:

- (a) Driven directly by a reciprocating internal combustion engine.
- (b) Driven via gears, or directly by an electric motor, and where the total length of shaft between propeller and thrust bearing is in excess of 60 times the intermediate shaft diameter.

3.3.2 Where an axial vibration damper is fitted, the calculations are to consider the effect of a malfunction of the damper.

3.3.3 For those systems as defined in *Pt 5, Ch 8, 3.3 Calculations 3.3.1* the propeller speed at which the critical frequency occurs may be estimated using the following formula:

$$\frac{0,98}{N} \left(\frac{ab}{a+b} \right)^{\frac{1}{2}} \text{ rev/min}$$

where

$$\mathbf{a} = \frac{E}{Gl^2} (66,2 + 97,5A - 8,88A^2)^2 \text{ (c/min)}^2$$

$$\mathbf{b} = 91,2 \frac{k}{M_e} \text{ (c/min)}^2$$

d = internal diameter of shaft, in mm

k = estimated stiffness at thrust block bearing, in N/m

l = length of shaft line between propeller and thrust bearing, in mm

m = mass of shaft line considered, in kg

$$= 0,785 (D^2 - d^2) G l$$

$$\mathbf{A} = \frac{m}{M}$$

D = outside diameter of shaft, taken as an average over length l , in mm

E = modulus of elasticity of shaft material, in N/mm²

G = density of shaft material, in kg/mm³

M = dry mass of propeller, in kg

$$M_e = M(A + 2)$$

N = number of propeller blades

Where the results of this method indicate the possibility of an axial vibration resonance in the vicinity of the maximum service speed, calculations using a more accurate method will be required.

3.4 Measurements

3.4.1 Where calculations indicate the possibility of excessive axial vibration amplitudes within the range of working speeds under normal or malfunction conditions, measurements are required to be taken from the shafting system for the purpose of determining the need for restricted speed ranges.

3.5 Restricted speed ranges

3.5.1 The limits of any speed restriction are to be such as to maintain axial amplitudes within recommended levels during continuous operation.

3.5.2 Limits of speed restriction, where required, may be determined by calculation or on the basis of measurement.

3.5.3 Where a speed restriction is imposed for the contingency of a damper malfunction, the speed limits are to be entered in the machinery Operating Manual and regular monitoring of the axial vibration amplitude is required. Details of proposals for monitoring are to be submitted.

3.6 Vibration monitoring

3.6.1 Where a vibration monitoring system is to be specified, details of proposals are to be submitted.

■ Section 4**Lateral vibration****4.1 General**

4.1.1 For all main propulsion shafting systems, the Shipbuilders are to ensure that lateral vibration characteristics are satisfactory throughout the speed range.

4.2 Particulars to be submitted

4.2.1 Calculations of the lateral vibration characteristics of shafting systems having supports outboard of the hull or incorporating cardan shafts are to be submitted.

4.3 Calculations

4.3.1 The calculations in *Pt 5, Ch 8, 4.2 Particulars to be submitted 4.2.1*, taking account of bearing, oil-film (where applicable) and structural dynamic stiffnesses, are to investigate the excitation frequencies giving rise to all critical speeds which may result in significant amplitudes within the speed range, and are to indicate relative deflections and bending moments throughout the shafting system.

4.3.2 The calculated natural frequencies of the system are to be compared to both the shaft rotational orders and propeller blade passing frequencies. Where cardan shafts are fitted, the shaft second rotational orders are also to be considered.

4.3.3 Requirements for calculations may be waived upon request provided evidence of satisfactory service experience of similar dynamic installations is submitted.

4.4 Measurements

4.4.1 Where calculations indicate the possibility of significant lateral vibration responses within the range of ± 20 per cent of M.C.R. speed, measurements using an appropriate recognised technique may be required to be taken from the shafting system for the purpose of determining the need for restricted speed ranges.

4.4.2 The method of measurement is to be appropriate to the machinery arrangement and the modes of vibration which are of concern. When measurements are required, detailed proposals are to be submitted in advance.

■ Section 5**Shaft alignment****5.1 General**

5.1.1 Shaft alignment calculations are to be carried out for main propulsion shafting rotating at propeller speed, including the crankshaft of direct drive systems or the final reduction gear wheel on geared installations. The Builder is to make available shaft alignment procedures detailing the proposed alignment method and checks for these arrangements.

5.2 Particulars to be submitted for approval – Shaft alignment calculations

5.2.1 Shaft alignment calculations are to be submitted to LR for approval for the following shafting systems:

- (a) All geared installations, where the screwshaft has a diameter of 300 mm or greater in way of the aftmost bearing.
- (b) All geared installations with multiple input/single output, regardless of shaft diameter.
- (c) All direct drive installations which incorporate three or fewer bearings supporting the intermediate and screwshaft aft of the prime mover.
- (d) Where prime movers in a direct drive installation or shaftline bearings are installed on resilient mountings.
- (e) All systems where the screwshaft has a diameter of 800 mm or greater in way of the aftmost bearing.

5.2.2 The shaft alignment calculations are to take into account the:

- (a) thermal displacements of the bearings between cold static and hot dynamic machinery conditions;
-

- (b) buoyancy effect of the propeller immersion due to the ship's operating draughts;
- (c) effect of predicted hull deformations over the range of the ship's operating draughts, where known;
- (d) effect of filling the aft peak ballast tank upon the bearing loads, where known;
- (e) gear forces, where appropriate, due to prime-mover engagement on multiple input/single output installations. For multiple input systems, consideration is to be given to each possible combination of inputs;
- (f) propeller offset thrust effects;
- (g) maximum allowed bearing wear, for water or grease-lubricated sterntube bearings, and its effect on the bearing loads.

5.2.3 The shaft alignment calculations are to state the:

- (a) expected bearing loads at light and normal ballast, fully loaded and any other draughts deemed to be part of the ship's operating profile, for the machinery in cold and hot, static and dynamic conditions;
- (b) bearing influence coefficients and the deflection, slope, bending moment and shear force along the shaftline;
- (c) details of propeller offset thrust;
- (d) details of proposed slope-bore of the aftermost sterntube bearing, where applicable;
- (e) manufacturer's specified limits for bending moment and shear force at the shaft couplings of the gearbox/prime movers;
- (f) estimated bearing wear rates for water or grease-lubricated sterntube bearings;
- (g) expected hull deformation effects and their origin, viz. whether finite element calculations or measured results from sister or similar ships have been used;
- (h) anticipated thermal rise of prime movers and gearing units between cold static and hot running conditions; and
- (i) manufacturer's allowable bearing loads.

5.3 Shaft alignment procedures

5.3.1 A shaft alignment procedure is to be made available for review and for the information of the attending surveyors for all main propulsion installations detailing, as a minimum,

- (a) expected bearing loads at light and normal ballast, fully loaded and any other draughts deemed to be part of the ship's operating profile, for the machinery in cold and hot, static and dynamic conditions;
- (b) maximum permissible loads for the proposed bearing designs;
- (c) design bearing offsets from the straight line;
- (d) design gaps and sags;
- (e) location and loads for the temporary shaft supports;
- (f) expected relative slope of the shaft and the bearing in the aftermost sterntube bearing;
- (g) details of slope-bore of the aftermost sterntube bearing, where applied;
- (h) proposed bearing load measurement technique and its estimated accuracy;
- (i) jack correction factors for each bearing where the bearing load is measured using a specified jacking technique;
- (j) proposed shaft alignment acceptance criteria, including the tolerances; and
- (k) flexible coupling alignment criteria.

5.4 Design and installation criteria

5.4.1 For main propulsion installations, the shafting is to be aligned to give, in all conditions of ship loading and machinery operation, bearing load distribution satisfying the requirements of *Pt 5, Ch 8, 5.4 Design and installation criteria 5.4.2*.

5.4.2 Design and installation of the shafting is to satisfy the following criteria:

- (a) The Builder is to position the bearings and construct the bearing seatings to minimise the effects of hull deflections under any of the ship's operating conditions with the aim of optimising the bearing load distribution.
- (b) Relative slope between the propeller shaft and the aftermost sterntube bearing is, in general, not to exceed 3×10^{-4} rad in the static condition..
- (c) Sterntube bearing loads are to satisfy the requirements of Ch 6,3.12.
- (d) Evidence is to be provided to LR demonstrating that bearings of synthetic material have been verified as being within the tolerance stated by the bearing manufacturer for diameter, ovality, and straightness after installation.
- (e) Bearings of synthetic material are to be verified as being within tolerance for ovality and straightness, circumferentially and longitudinally, after installation.

- (f) The sterntube forward bearing static load is to be sufficient to prevent unloading in all static and dynamic operating conditions, including the transient conditions experienced during manoeuvring turns and during operation in heavy weather.
- (g) Intermediate shaft bearings' loads are not to exceed 80 per cent of the bearing manufacturer's allowable maximum load, for plain journal bearings, based on the bearing projected area.
- (h) Equipment manufacturer's bearing loads are to be within the manufacturer's specified limits, i.e. prime movers, gearing.
- (i) Resulting shear forces and bending moments are to meet the equipment manufacturer's specified coupling conditions.
- (j) The manufacturer's radial, axial and angular alignment limits for the flexible couplings are to be maintained.

5.5 Measurements

5.5.1 The system bearing load measurements are to be carried out to verify that the design loads have been achieved. In general the measurements will be carried out by the jack-up measurement technique using calibrated equipment.

5.5.2 For the first vessel of a new design an agreed programme of static shaft alignment measurements is to be carried out in order to verify that the shafting has been installed in accordance with the design assumptions and to verify the design assumptions in respect of the hull deflections and the effects of machinery temperature changes. The programme is to include static bearing load measurements in a number of selected conditions. Depending on the ship type and the operational loading conditions that are achievable prior to and during sea trials these should include, where practicable, combinations of light ballast cold, full ballast cold, full ballast hot and full draught hot with aft peak tank empty and full.

5.5.3 For vessels of an existing design or similar to an existing design where evidence of satisfactory service experience is submitted for consideration and for subsequent ships in a series a reduced set of measurements may be accepted. In such cases the minimum set of measurements is to be sufficient to verify that the shafting has been installed in accordance with the design assumptions and are to include at least one cold and one hot representative condition.

5.5.4 Where calculations indicate that the system is sensitive to changes in alignment under different service conditions, the shaft alignment is to be verified by measurements during sea trials using an approved strain gauge technique.

5.6 Flexible couplings

5.6.1 Where the shafting system incorporates flexible couplings, the effects of such couplings on the various modes of vibration are to be considered, see *Pt 5, Ch 8, 2 Torsional vibration, Pt 5, Ch 8, 3 Axial vibration and Pt 5, Ch 8, 4 Lateral vibration.*

Section

- 1 **Scope**
- 2 **General requirements**
- 3 **Functional capability**
- 4 **Materials**
- 5 **Structure design and construction requirements**
- 6 **Machinery design and construction requirements**
- 7 **Electrical equipment**
- 8 **Control engineering systems**
- 9 **Testing and trials**
- 10 **Installation, maintenance and replacement procedures**

■ Section 1

Scope

1.1 General

1.1.1 This Chapter applies to podded propulsion units where used for propulsion, dynamic positioning duty or as the sole means of steering.

1.1.2 For the purposes of these Rules, a podded propulsion unit is any propulsion or manoeuvring device that is external to the normal form of the ship's hull and houses a propeller powering device.

1.1.3 The requirements of this Chapter relate to podded propulsion units powered by electric propulsion motors, (and are in addition to the requirements for Electric Propulsion in *Pt 6, Ch 2, 16 Electric propulsion* and other relevant Sections). Podded propulsion units with other drive arrangements will be subject to individual consideration.

1.1.4 The structural requirements stated in *Pt 5, Ch 9, 5.1 Pod structure, Pt 5, Ch 9, 5.2 Hull support structure* and *Pt 5, Ch 9, 5.3 Direct calculations* relate to podded propulsion units having a pod body with single supporting strut with or without an integral slewing ring arrangement, see *Figure 9.1.1 Podded propulsion unit*. Novel and unconventional arrangements will be subject to individual consideration. In such cases, the designers are advised to contact LR in the early stages of the design for advice on the manner and content of design information required for formal classification appraisal.

1.1.5 The aft end structures associated with podded installations are to be examined with respect to potential slamming, see *Pt 4, Ch 2 Ferries, Roll On-Roll Off Ships and Passenger Ships*.

1.1.6 It is the shipbuilder's responsibility to ensure that all installed equipment is suitable for operation in the location and under all anticipated environmental conditions associated with the design of the ship which is to include temperature, humidity, vibration and impulsive accelerations.

1.1.7 The design of a podded propulsor system is to take into account a range of operating conditions which are to include the following:

- All ahead seagoing conditions up to and including the maximum rated output of the podded propulsor while maintaining a steady course under foreseeable sea and wind conditions.
- The ability of the ship to change direction rapidly at the declared steering angles with the ship running at maximum ahead service speed.
- Executing a steady turning manoeuvre with a tactical diameter not greater than $5L$ and advance not greater than $4,5L$ whilst maintaining a power corresponding to the test speed, where L is the length measured between the aft and forward perpendiculars. Test speed is defined as a speed of at least 90 per cent of the ship's speed corresponding to 85 per cent of the maximum rated power of the podded propulsor.

- Changing heading, manoeuvring in and out of harbour both ahead and astern, at slow speeds, stationary and starting from rest in foreseeable current and wind conditions.
- Berthing manoeuvres in the case of azimuthing podded propulsion units.
- Rapid acceleration and deceleration manoeuvres where the ship's operating profile demands this capability.
- Holding stationary positions over-ground under different conditions.
- Stopping manoeuvre as required by *Pt 5, Ch 1, 5.2 Sea trials*.
- Manoeuvring in ice where ice class is required.

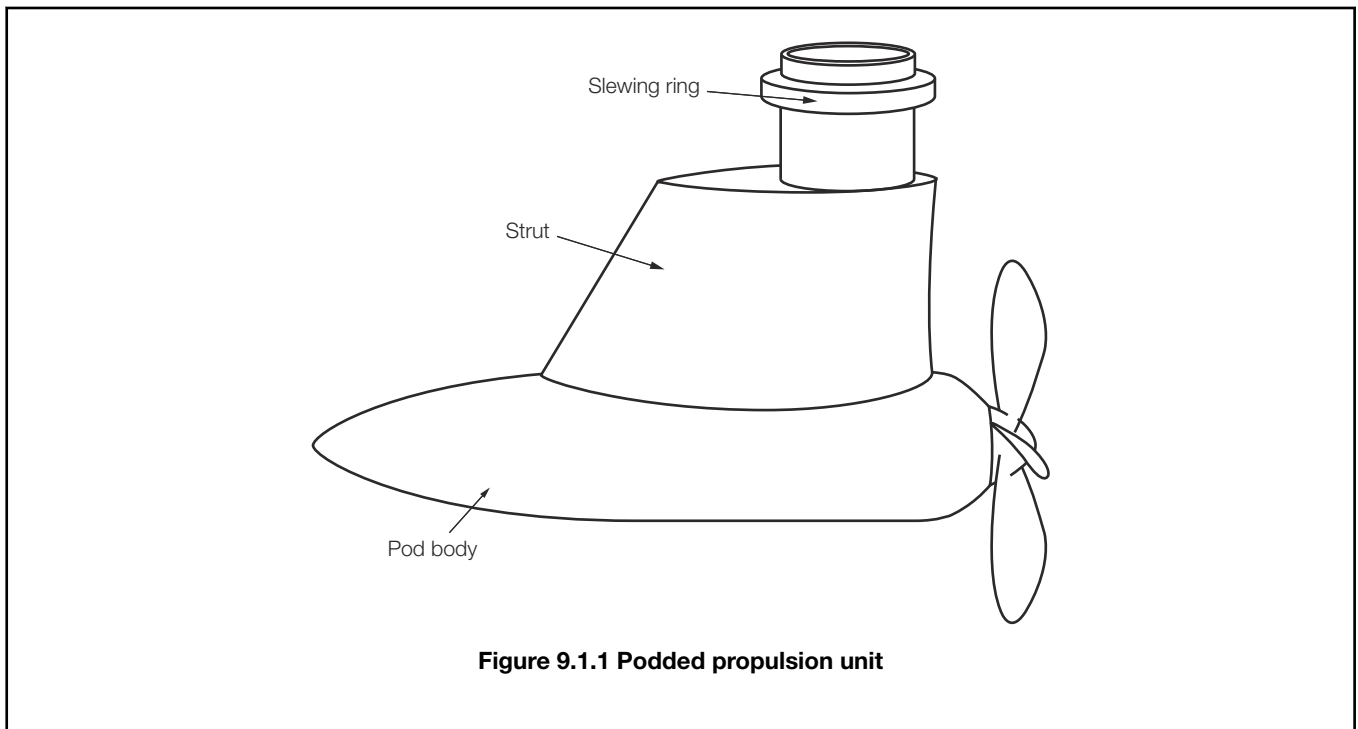
**Figure 9.1.1 Podded propulsion unit**

■ Section 2 General requirements

2.1 Pod arrangement

2.1.1 In general, for a ship to be assigned an unrestricted service notation, a minimum of two podded propulsion units are to be provided where these form the sole means of propulsion. For vessels where a single podded propulsion unit is the sole means of propulsion, an evaluation of a detailed engineering and safety justification will be conducted by LR, see *Pt 5, Ch 9, 2.2 Plans and information to be submitted*. This evaluation process will include the appraisal of a Failure Modes and Effects Analysis (FMEA) to verify that sufficient levels of redundancy and monitoring are incorporated in the podded propulsion unit's essential support systems and operating equipment.

2.2 Plans and information to be submitted

2.2.1 In addition to the plans required by Chapters *Pt 5, Ch 5 Gearing, Pt 5, Ch 6 Main Propulsion Shafting, Pt 5, Ch 7 Propellers, Pt 5, Ch 8 Shaft Vibration and Alignment, Pt 5, Ch 14 Machinery Piping Systems* and *Pt 5, Ch 19 Steering Arrangements*, and *Pt 6, Ch 1 Control Engineering Systems* and *Pt 6, Ch 2 Electrical Engineering*, the following plans and information are required to be submitted for appraisal:

- (a) Description of the ship's purpose/capabilities together with the pod's intended operational modes in support of these capabilities.
- (b) Power transmitted at MCR condition (shaft power and rpm) and other maximum torque conditions, e.g. bollard pull.
- (c) Maximum transient thrust, torque and other forces and moments experienced during all envisaged operating modes as permitted by the steering and propulsor drive control systems.

-
- (d) Details of the electric propulsion motor short-circuit torque and motor air gap tolerance.
- (e) Sectional assembly in the Z-X plane, see *Figure 9.2.1 Pod co-ordinate system*.
- (f) Specifications of materials and NDE procedures for components essential for propulsion and steering operation to include propulsion shaft and slewing ring bearings, gearing and couplings, see *Pt 5, Ch 9, 4.1 General*.
- (g) Details of intended manoeuvring capability of the ship in each operating condition. (To be declared by the shipyard, see also *Pt 5, Ch 9, 3.1 General 3.1.1*)
- (h) Design loads for both the pod structure and propeller together with podded propulsion unit design operating modes (see *Pt 5, Ch 9, 2.4 Global loads 2.4.1, Pt 5, Ch 9, 6.3 Propulsion shafting 6.3.7, Pt 5, Ch 9, 6.6 Steering system 6.6.6 and Pt 5, Ch 9, 6.6 Steering system 6.6.7*).
- (i) Supporting data and direct calculation reports. This is to include, where applicable, an assessment of anticipated global accelerations acting on the ship's machinery and equipment which may potentially affect the reliable operation of the propulsion system for all foreseeable seagoing and operating conditions. Typically, this may include response to slamming, extreme ship motions and pod interaction. See also *Pt 5, Ch 9, 1.1 General 1.1.5*.
- (j) Structural component details including: strut, pod body, bearing supports, bearing end caps, ship's structure in way of podded propulsion unit integration and a welding Table showing a key to weld symbols used on the plans specifying weld size, type, preparation and heat treatment. The information should include the following:
- Detailed drawings showing the structural arrangement, dimensions and scantlings.
 - Welding and structural details.
 - Connections between structural components (bolting).
 - Casting's chemical and mechanical properties.
 - Forging's chemical and mechanical properties.
 - Material grades for plate and sections
- (k) Nozzle structure, its support arrangements, together with related calculations for all permitted operating conditions where the propeller operates in a nozzle (duct), see *Pt 3, Ch 13, 3 Fixed and steering nozzles*.
- (l) Propeller shaft bearing mounting and housing arrangement details, see also *Pt 5, Ch 9, 6.3 Propulsion shafting 6.3.6*
- (m) Details of propeller shaft and steering bearings, where roller bearings are used supporting calculations are to be submitted, see *Pt 5, Ch 9, 6.3 Propulsion shafting 6.3.7 and Pt 5, Ch 9, 6.6 Steering system 6.6.7*.
- (n) Propeller shaft seal details.
- (o) Details of propeller shaft and pod steering securing/locking and means of aligning the securing/locking arrangements.
- (p) Cooling systems piping system schematic.
- (q) Details of any lubricating oil conditioning systems (filtering/cooling/heating) and control arrangements necessary to ensure the continuous availability of the required lubricating oil quality to the propeller shaft bearings.
- (r) Details of installed condition monitoring equipment.
- (s) Details of the derivation of any duty factor used in the design of the steering gears.
- (t) Identification of any potentially hazardous atmospheric conditions together with details of how the hazard will be countered, this should include a statement of the maximum anticipated air temperature within the pod during full power steady state operation, see *Pt 5, Ch 9, 2.3 Pod internal atmospheric conditions*
- (u) Where provided, access and closing arrangements for pod unit inspection and maintenance.
- (v) Heat balance calculations for pods having an electric propulsion motor but no active cooling system, see *Pt 5, Ch 9, 6.7 Ventilation and cooling systems 6.7.4*.
- (w) Details of proposed testing and trials required by *Pt 5, Ch 9, 9 Testing and trials*.
- (x) Details of emergency steering and pod securing arrangements. See *Pt 5, Ch 9, 6.3 Propulsion shafting 6.3.11*.
- (y) Quality plan for electronic control systems and electrical actuating systems.

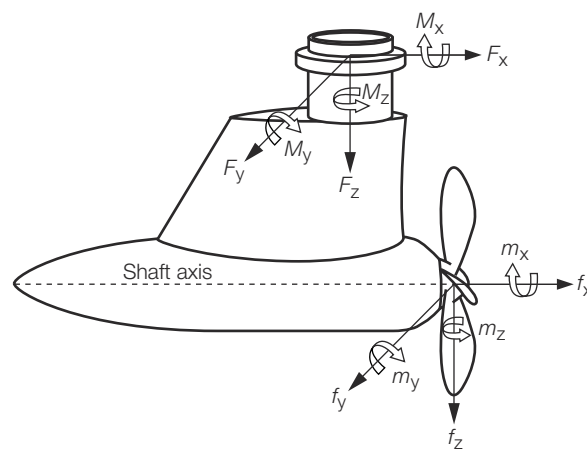

Figure 9.2.1 Pod co-ordinate system

2.2.2 Where an engineering and safety justification report is required, the following supporting information is to be submitted:

- A Failure Mode and Effects Analysis (FMEA), see Pt 5, Ch 9, 2.5 Failure Modes and Effects Analysis (FMEA).
- Design standards and assumptions.
- Limiting operating parameters.
- A statement and evidence in respect of the anticipated reliability of any non-duplicated components.

2.2.3 Recommended installation, inspection, maintenance and component replacement procedures (see also Pt 5, Ch 9, 5.1 Pod structure 5.1.2). This is to include any in-water/underwater engineering procedures where recommended by the pod manufacturer. See also Pt 5, Ch 9, 6.5 Bearing lubrication system 6.5.7 and Pt 5, Ch 9, 10 Installation, maintenance and replacement procedures.

2.3 Pod internal atmospheric conditions

2.3.1 Machinery and electrical equipment installed within the pod unit are to be suitable for operation, without degraded performance, at the maximum anticipated air temperature and humidity conditions within the pod unit with the pod operating at its maximum continuous rating in sea water of not less than 32°C after steady state operating conditions have been achieved.

2.3.2 Precautions are to be taken to prevent as far as reasonably practicable the possibility of danger to personnel and damage to equipment arising from the development of hazardous atmospheric conditions within the pod unit. Circumstances that may give rise to these conditions are to be identified and the counter measures taken are to be defined.

2.4 Global loads

2.4.1 The overall strength of the podded propulsion unit structure is to be based upon the maximum anticipated in-service loads, including, the effects of ship manoeuvring and of ship motion (see Table 14.8.1 Ship motions, in Pt 3, Ch 14 Cargo Securing Arrangements). This is to include the effects of any pod to pod and/or pod to ship hydrodynamic interference effects. The designer is to supply the following maximum load and moment values to which the unit may be subjected with a description of the operating conditions at which they occur.

- F_x , Force in the longitudinal direction;
- F_y , Force in the transverse direction;
- F_z , self weight, in water, augmented by the ship's pitch and heave motion and flooded volume where applicable, see Pt 3, Ch 14 Cargo Securing Arrangements;
- M_x , moment at the slewing ring about the pod unit's global longitudinal axis;
- M_y , moment at the slewing ring about the pod unit's global transverse axis;
- M_z , moment at the slewing ring about the pod unit's vertical axis (maximum dynamic duty steering torque on steerable pods).

The directions of the X, Y and Z axes, with the origin at the centre of the slewing ring, are shown in *Figure 9.2.1 Pod co-ordinate system*.

2.4.2 Where the maximum forces and moments defined in *Pt 5, Ch 9, 2.4 Global loads 2.4.1* cannot be accurately calculated, then, an estimate of these loadings is to be stated together with an assessment of the associated error tolerances for the sequences of permitted design manoeuvres, see *Pt 5, Ch 9, 1.1 General 1.1.7*. Typically this will include emergency astern manoeuvres, zig zag manoeuvres and pod interaction. Such estimates are to be defined on a load versus pod angle basis. In the case of pod to pod and/or pod to ship hydrodynamic interaction effects these, must be defined for the most severely affected propulsor.

2.4.3 Where control systems are installed to limit the operation of the podded drive to defined angles at defined ship speeds, this information may be taken into consideration when determining the pod unit loading.

2.4.4 Where pod units are fixed about their Z axis, then maximum global loads, to be used as the basis of the structural appraisal, are to be determined for inflows in 5 degree increments between the extremes of anticipated inflow angle during manoeuvring with ship at full speed and maximum propeller thrust.

2.4.5 The podded propulsor is to be capable of withstanding a blade root failure due to fatigue occurring at the maximum rated output of the podded propulsor without initiating a failure in other parts of the propulsor system.

2.5 Failure Modes and Effects Analysis (FMEA)

2.5.1 An FMEA is to be carried out where a single podded propulsion unit is the vessel's sole means of propulsion, see *Pt 5, Ch 9, 2.1 Pod arrangement 2.1.1*. The FMEA is to identify components where a single failure could cause loss of all propulsion and/or steering capability and the proposed arrangements for preventing and mitigating the effects of such a failure. The assessment required by *Pt 6, Ch 2, 16.2 System design and arrangement 16.2.2* may be considered for demonstrating the acceptability of the proposed design for propulsion power purposes.

2.5.2 The FMEA is to be carried out using the format presented in *Table 22.2.1 Failure Mode and Effects Analysis* in *Pt 5, Ch 22 Propulsion and Steering Machinery Redundancy* or an equivalent format that addresses the same reliability issues. Analyses in accordance with IEC 60812, *Analysis techniques for system reliability – Procedure for failure mode and effects analysis (FMEA)*, or IMO MSC Resolution 36(63) *Annex 4 - Procedures for Failure Mode and Effects Analysis – Procedures for Failure Mode and Effects Analysis*, would be acceptable.

2.5.3 The FMEA is to be organised in terms of equipment and function. The effects of item failures at a stated level and at higher levels are to be analysed to determine the effects on the system as a whole. Actions for mitigation of the effects of failure are to be determined, see *Pt 5, Ch 9, 2.5 Failure Modes and Effects Analysis (FMEA) 2.5.1*.

2.5.4 The FMEA is to:

- (a) identify the equipment or sub-system and mode of operation;
- (b) identify potential failure modes and their causes;
- (c) evaluate the effects on the system of each failure mode;
- (d) identify measures for reducing the risks associated with each failure mode;
- (e) identify measures for preventing failure; and
- (f) identify trials and testing necessary to prove conclusions.

2.5.5 At sub-system level it is acceptable, for the purpose of these Rules, to consider failure of equipment items and their functions, e.g. failure of a pump to produce flow or pressure head. It is not required that the failure of components within that pump be analysed. In addition, their failure need only be dealt with as a cause of failure of the pump.

2.5.6 Where FMEA is used for consideration of systems that depend on software-based functions for control or coordination, the analysis is to investigate failure of the functions rather than a specific analysis of the software code itself.

2.6 Ice Class requirements

2.6.1 Where an ice class notation is included in the class of a ship, additional requirements as detailed in *Pt 8 Rules for Ice and Cold Operations* are to be complied with as applicable.

■ Section 3 Functional capability

3.1 General

3.1.1 The arrangement of podded propulsion units is to be such that the ship can be satisfactorily manoeuvred to a declared performance capability. The operating conditions covered are to include the following:

- (a) Maximum continuous shaft power/speed to the propeller in the ahead condition at the declared steering angles and sea conditions.
- (b) Manoeuvring speeds of the propeller shaft in the ahead and astern direction at the declared steering angles and sea conditions.
- (c) The stopping manoeuvre described in *Pt 5, Ch 1, 5.2 Sea trials 5.2.2*.
- (d) All astern running conditions for the ship.
- (e) Manoeuvring in ice where ice class is required.

3.1.2 The main steering arrangements are to be operated by power and capable of changing the direction of the ship's podded propulsion units from one side to the other at declared steering angle limits at an average rotational speed of not less than 0,4 rev/min with the ship initially operating at its maximum ahead service speed.

3.1.3 The steering mechanism for podded units used for Dynamic Positioning applications with an associated class notation, is to be capable of a rotational speed of not less than 1,5 rev/min.

3.1.4 The auxiliary steering arrangements are to be:

- (a) Capable of changing the direction of the ship's podded propulsion units from one side to the other at declared steering angle limits at an average rotational speed of not less than 0,083 rev/min, with the ship running ahead at one half of the maximum ahead service speed or 7 knots, whichever is the greater.
- (b) Operated by power for ships having propulsion power of more than 2500 kW per podded propulsion unit and for all ships, where it is necessary, to meet the requirements of *Pt 5, Ch 9, 3.1 General 3.1.4*.

■ Section 4 Materials

4.1 General

4.1.1 The materials used for major structural and machinery components are to be manufactured and tested in accordance with the requirements of the *Rules for the Manufacture, Testing and Certification of Materials, July 2015* (hereinafter referred to as the Rules for Materials). These components include hull support structure, pod body, pod strut, shafting and propellers.

4.1.2 Components of novel design or components manufactured from materials not covered by the *Rules for the Manufacture, Testing and Certification of Materials, July 2015* are to be subject to evaluation and approval by Lloyd's Register (hereinafter referred to as 'LR') prior to manufacture.

4.1.3 Material specifications, see *Pt 5, Ch 9, 2.2 Plans and information to be submitted 2.2.1*, for propulsion shaft and slewing ring bearings, gearing and couplings are to be approved by LR prior to manufacture. The specification is to include details of the grade of material, including the target range of chemical composition that is to be reported on the certificate, the required mechanical properties, heat treatment details including temperatures and hold times, details of necessary non-destructive examinations including acceptance levels. Additionally, any steel cleanliness or microstructure requirements are to be included. These components are to be manufactured under survey.

4.1.4 For propulsion shaft rolling element bearings, the amount of retained austenite is to be determined and is not to exceed 4 per cent for nominally bainitic structures.

4.1.5 Where load carrying threaded fasteners screw directly into structural castings, the integrity of the casting is to be such that there is no porosity or shrinkage in the area of the connection.

■ *Section 5***Structure design and construction requirements****5.1 Pod structure**

5.1.1 Podded unit struts and pod bodies may be of cast, forged or fabricated construction or a combination of these construction methods.

5.1.2 Means are to be provided to enable the shaft, bearings and seal arrangements to be examined in accordance with LR's requirements and the manufacturer's recommendations.

5.1.3 When high tensile steel fasteners are used as part of the structural arrangement and there is a risk that these fasteners may come into contact with sea-water, carbon-manganese and low alloy steels with a specified tensile strength of greater than 950 N/mm² are not to be used due to the risk of hydrogen embrittlement.

5.1.4 For steerable pod units, an integral slewing ring is to be arranged at the upper extremity of the strut to provide support for the slewing bearing.

5.1.5 The strut is to have a smooth transition from the upper mounting to the lower hydrodynamic sections.

5.1.6 For fabricated structures, vertical and horizontal plate diaphragms are to be arranged within the strut and, where necessary, secondary stiffening members are to be arranged.

5.1.7 Pod unit structure scantling requirements are shown in *Table 9.5.1 Podded propulsion unit – Fabricated structure requirements*. Where the scantling requirements in *Table 9.5.1 Podded propulsion unit – Fabricated structure requirements* cannot be satisfied, direct calculations carried out in accordance with *Pt 5, Ch 9, 5.3 Direct calculations* may be considered.

Table 9.5.1 Podded propulsion unit – Fabricated structure requirements

Location	Requirement	Notes
Strut external shell plating	Thickness, in mm, is to be not less than: $t = 0,0063s f (h_7 k)^{0,5}$	The minimum thickness of plating diaphragms and primary webs within the strut is to be not less than the Rule requirement for the strut external plating. For internal diaphragms, panel stiffening is to be provided where the ratio of spacing to plate thickness (s/t) exceeds 100. Where there are no secondary members, s is to be replaced by S.
Strut primary framing	The section modulus in cm ³ is to be not less than: $z = 7,75h_7 l_e^2 e^s k$	This does not apply to full breadth plate diaphragms.
Strut secondary stiffening	The section in cm ³ is to be not less than: $z = 0,0056h_7 l_e^2 e^s k$	This does not apply to full breadth plate diaphragms.
Cylindrical pod body external shell plating	Thickness, in mm, is to be not less than: $t = 3,0R_g (h_7 k)^{0,5}$	Not to be less than the Rule basic shell end thickness from <i>Table 3.2.1 Taper requirements for hull envelope</i> in <i>Pt 3, Ch 3, 2 Rule structural concepts</i>
Symbols		
<p>f = panel aspect ratio correction factor = [1,1 – s/(2500S)]</p> <p>h_7 = $(T + C_w + 0,014V^2)$</p> <p>k = local higher tensile steel factor, as in <i>Pt 3, Ch 2 Materials</i></p> <p>l_e = effective span of the member under consideration, in metres</p> <p>s = the frame spacing of secondary members, in mm</p> <p>C_w = design wave amplitude, in metres, as in <i>Pt 4, Ch 1, 1.5 Symbols and definitions</i></p> <p>R_g = mean radius of pod body tube, in metres</p> <p>S = the spacing of primary members, in metres</p> <p>T = the vessel scantling draft, in metres, as in <i>Pt 3, Ch 1, 6.1 Principal particulars</i></p> <p>V = ship service speed, in knots, as in <i>Pt 3, Ch 1, 6.1 Principal particulars</i>.</p>		

5.1.8 The connection between the strut and the pod body should generally be effected through large radiused fillets in cast pod units or curved plates in fabricated pod units.

5.1.9 The structural response under the most onerous combination of loads is not to exceed the normal operational requirements of the propulsion or steering system components.

5.1.10 For cast pod structures, the elongation of the material on a gauge length of $5,65\sqrt{S_0}$ is to be not less than 12 per cent where S_0 is the actual cross sectional area of the test piece.

5.1.11 In castings, sudden changes of section or possible constriction to the flow of metal during casting are to be avoided. All fillets are to have adequate radii, which should, in general, be not less than 75 mm.

5.1.12 Castings are to comply with the requirements of *Ch 4 Steel Castings* or *Ch 7 Iron Castings* of the Rules for Materials.

5.2 Hull support structure

5.2.1 For supporting the main slewing bearing outer races, a system of primary structural members is to be provided in order to transfer the maximum design loads and moments from the podded propulsion unit into the ship's hull without undue deflection. Due account is also to be taken of the loads induced by the maximum ship's motions in the vertical direction resulting from combined heave and pitch motion of the ship. Account is also to be taken of any manoeuvring conditions that are likely to give rise to high mean or vibratory loadings induced by the podded propulsion unit. See Pt 5, Ch 9, 2.2 Plans and information to be submitted 2.2.1.

5.2.2 The hull support structure in way of the slewing bearing should be sufficiently stiff that the bearing manufacturer's limits on seating flatness are not exceeded due to hull flexure as a consequence of the loads defined under Pt 5, Ch 9, 5.2 Hull support structure 5.2.1.

5.2.3 Generally, the system of primary members is to comprise a pedestal girder directly supporting the slewing ring and bearing. The pedestal girder is to be integrated with the ship's structure by means of radial girders and transverses aligned at their outer ends with the ship's bottom girders and transverses, see Figure 9.5.1 Hull support structure. Proposals to use alternative arrangements that provide an equivalent degree of strength and rigidity may be submitted for appraisal.

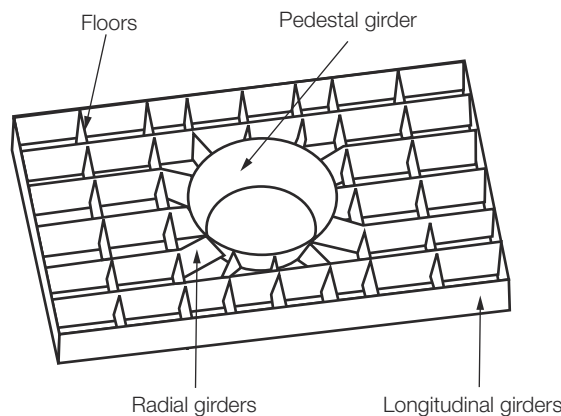

Figure 9.5.1 Hull support structure

5.2.4 The ship's support structure in way of the podded unit may be of double or single bottom construction. Generally, podded drives should be supported where practical within a double bottom structure; however final acceptance of the supporting arrangements will be dependent upon satisfying the stress criteria set out in Table 9.5.2 Direct calculation maximum permissible stresses for steel fabricated structures, see also Pt 5, Ch 9, 5.3 Direct calculations 5.3.5.

Table 9.5.2 Direct calculation maximum permissible stresses for steel fabricated structures

Permissible stress values		
Location	Podded drive structure	Podded drive/hull interface
X-Y shear stress	$0,26\sigma_0$	$0,35\sigma_0$
Direct stress due to bending	$0,33\sigma_0$	$0,63\sigma_0$
Von Mises stress	$0,40\sigma_0$	$0,75\sigma_0$
Localised Von Mises peak stresses	σ_0	σ_0
Symbols		

σ_0 = minimum yield strength of the material

Note 1. The values stated above are intended to give an indication of the levels of stress in the pod and ship structure for the maximum loads which could be experienced during normal service.

Note 2. If design is based on extreme or statistically low probability loads, then proposals to use alternative acceptance stress criteria may be considered.

5.2.5 The shell envelope plating and tank top plating in way of the aperture for the podded drive (i.e. over the extent of the radial girders shown in *Figure 9.5.1 Hull support structure*) are to be increased by 50 per cent over the Rule minimum thickness to provide additional local stiffness and robustness. However the thickness of this plating is not to be less than the actual fitted thickness of the surrounding shell or tank top plating.

5.2.6 The scantlings of the primary support structure in way of the podded drive are to be based upon the limiting design stress criteria specified in *Table 9.5.2 Direct calculation maximum permissible stresses for steel fabricated structures*, see also *Pt 5, Ch 9, 5.3 Direct calculations 5.3.5 Primary member scantlings* are, however, not to be less than those required by *Pt 3, Ch 6, 5 Single and double bottom structure*

5.2.7 The pedestal girder is to have a thickness not less than the required shell envelope minimum Rule thickness in way. Where abutting plates are of dissimilar thickness then the taper requirements of *Pt 3, Ch 10, 2 Welding* are to be complied with.

5.2.8 In general, full penetration welds are to be applied at the pedestal girder boundaries and in way of the end connections between the radial girders and the pedestal girder. Elsewhere, for primary members, double continuous fillet welding is to be applied using a minimum weld factor of 0,34.

5.3 Direct calculations

5.3.1 Finite element or other direct calculation techniques may be employed in the verification of the structural design. The mesh density used is to be sufficient to accurately demonstrate the response characteristics of the structure and to provide adequate stress and deflection information. A refined mesh density is to be applied to geometry transition areas and those locations where high localised stress or stress gradients are anticipated.

5.3.2 Model boundary constraints are generally to be applied in way of the slewing ring/ship attachment only.

5.3.3 The loads applied to the mathematical model, see *Pt 5, Ch 9, 2.4 Global loads 2.4.1*, are to include the self weight, dynamic acceleration due to ship motion, hydrodynamic loads, hydrostatic pressure, propeller forces and shaft bearing support forces. In situations where a pod can operate in the flooded conditions or where flooding of a pod adds significant mass to the pod, details are to be included.

5.3.4 Based on the most onerous combination of normal service loading conditions, the stress criteria shown in *Table 9.5.2 Direct calculation maximum permissible stresses for steel fabricated structures* are not to be exceeded. See also *Pt 5, Ch 9, 2.2 Plans and information to be submitted 2.2.1*.

5.3.5 Where the structural design is based on a fatigue assessment and the stress criteria shown in *Table 9.5.2 Direct calculation maximum permissible stresses for steel fabricated structures* are not applicable, details of cumulative load history and stress range together with the proposed acceptance criteria are to be submitted for consideration.

5.3.6 For cast structures, the localised von Mises stress should not exceed 0,6 times the nominal 0,2 per cent proof or yield stress of the material for the most onerous design condition.

■ Section 6 **Machinery design and construction requirements**

6.1 General

6.1.1 The requirements detailed in Chapter 1 are applicable.

6.1.2 Means are to be provided whereby normal operation of the podded propulsion system can be sustained or readily restored if one of the supporting auxiliaries becomes inoperative, see also *Pt 5, Ch 9, 2.1 Pod arrangement 2.1.1*. Consideration shall be given to the malfunctioning of:

- sources of lubricating oil pressure,
- sources of cooling,
- hydraulic, pneumatic or electrical means for control of the podded propulsor.

6.2 Gearing

6.2.1 If gearing is used in the propulsion system then the requirements of *Pt 5, Ch 5 Gearing* are applicable.

6.3 Propulsion shafting

6.3.1 In addition to meeting the requirements of *Pt 5, Ch 6 Main Propulsion Shafting* and *Pt 5, Ch 8 Shaft Vibration and Alignment*, the pod propulsion shafting supporting an electric motor is to be sufficiently stiff that both static and dynamic shaft flexure are within the motor manufacturer's limits for all envisaged operating conditions.

6.3.2 There is to be no significant lateral vibration response that may cause damage to the shaft seals within ± 20 per cent of the running speed range. For vibration analysis computations the influence of the slewing ring and shaft bearing stiffnesses together with the contribution from the seating stiffnesses are to be included in the calculation procedures.

6.3.3 As an alternative to the requirements of *Pt 5, Ch 6 Main Propulsion Shafting*, a fatigue strength analysis of shafting components indicating a factor of safety of 1,5 at the design loads based on a suitable fatigue failure criterion may be submitted for consideration. The effects of stress concentrations, material properties and operating environment are to be taken into account.

6.3.4 With the exception of the propeller connection (requirements stated in *Pt 5, Ch 7 Propellers*) couplings relying on friction are to have a factor of safety of 2,5 against slippage at the maximum rated torque. In order to reduce the possibility of fretting, a grip stress of not less than 20 N/mm² is to be attained.

6.3.5 The effects of motor short-circuit torque on the shafting system should not prevent continued operation once the fault has been rectified.

6.3.6 The arrangement of shaft bearings is to take account of shaft thermal expansion, misalignment of bearings, shaft slope through the bearings and manufacturing tolerances. Additionally, the influence of the pod deflection on the shaft bearing alignment is to be considered under the most onerous mechanical and hydrodynamic loading conditions.

6.3.7 Propeller shaft roller bearing life calculations are to take account of the following loadings:

- Shaft, motor, propeller and other shaft appendages' weights;
- Forces due to ship's motion;
- The propeller-generated forces and moments about the three Cartesian axes related to the shaft; f_x , f_y , f_z , m_x , m_y , m_z , see *Figure 9.2.1 Pod co-ordinate system*;
- Variance of propeller-generated forces and moments with pod azimuth angle. This load variance should take account of the motor control characteristics;
- Forces due to pod rotation, including gyroscopic forces;
- A predicted azimuth service profile for the pod indicating the proportion of time spent at various azimuth angles;
- Loads due to hydrodynamic interaction between pods;
- Any additional loads experienced during operation in ice conditions (for Ice Class notations);
- Where validation of the above loadings is available, detailed calculations must demonstrate that the bearing life when operating at the normal duty profile will comfortably exceed the time between 5-yearly surveys. Parameters used to justify the bearing life, i.e. those related to oil cleanliness, viscosity limits and material quality are to be quoted.

6.3.8 Where detailed validation of the loadings identified in *Pt 5, Ch 9, 6.3 Propulsion shafting 6.3.7* is not available, the calculations for roller bearings are to indicate a bearing life greater than 65,000 hours at the maximum continuous rating of the podded drive taking into account the azimuth angle duty cycle. Any parameters used to justify this life, i.e. those related to oil cleanliness, water contamination and viscosity limits are to be quoted. Proposals for the use of a shaft bearing of life less than 65,000 hours will be considered on application with details of alleviating factors and supporting documentation; however, this bearing life must exceed the time between surveys.

6.3.9 The design of the shaft line bearings is to take account of the maximum and minimum operating temperatures likely to be encountered during both a voyage cycle and, more widely, during the ship's operational life. Furthermore, any anticipated temperature distributions through the bearing components and structures are to be included in the design calculations.

6.3.10 Means are to be provided for detecting shaft bearing deterioration. Where rolling element shaft bearings are used in single pod applications or in pods where the motor power exceeds 6 MW, vibration monitoring of the shaft bearings is to be provided. The bearing monitoring system is to be suitable for the local bearing conditions and is to be able to differentiate from other vibration sources such as propeller cavitation or ship motions.

6.3.11 In multi-podded propulsor systems or ships having at least one pod in association with other propulsion devices and where the individual pod installed power is greater than 5MW, means are to be provided to hold the propeller for an inoperable unit stationary whilst the other pod(s) propel the vessel at a manoeuvring speed of not less than 7 knots. Operating instructions displayed at the holding mechanism's operating position are to include a direction to inform the bridge of any limitation in ships speed required as a result of the holding mechanism being activated.

6.3.12 Shaft seals for maintaining the watertight integrity of the pod are to be Type Approved to a standard acceptable to LR. The seals are to be designed to withstand the extremes of operation for which they are intended and this is to include extremes of temperature, vibration, pressure and shaft movement.

6.3.13 In single pod installations, the integrity of shaft seals is to be evaluated on the basis of a double failure. In such installations, seal duplication is to be used with indication of failure of one seal being provided.

6.4 Propeller

6.4.1 The requirements of *Pt 5, Ch 7 Propellers* are to be complied with.

6.4.2 Where propeller scantlings have been determined by a detailed fatigue analysis, based on reliable wake survey data as described in *Pt 5, Ch 7, 3.1 Minimum blade thickness 3.1.7* a factor of safety of 1,5 against suitable fatigue failure criteria is to be demonstrated. The effects of fillet stress concentrations, residual stress, fluctuating loads and material properties are to be taken into account.

6.5 Bearing lubrication system

6.5.1 The bearing lubrication system is to be arranged to provide a sufficient quantity of lubricant of a quality, viscosity and temperature acceptable to the bearing manufacturer under all ship operating conditions.

6.5.2 In addition to the requirements detailed in this Section, the requirements of *Pt 5, Ch 14 Machinery Piping Systems*, sub-Sections *Pt 5, Ch 9, 8.1 General, 8.5, 8.7 and 8.9* are to be complied with.

6.5.3 For systems employing forced lubrication, the sampling points required by *Pt 5, Ch 14, 8.13 Deep tank valves and their control arrangements 8.13.6* are to be located such that the sample taken is representative of the oil present at the bearing.

6.5.4 For lubricating oil systems employing gravity feed, the arrangements are to be such as to permit oil sampling and oil changes in accordance with the manufacturer's instructions for the safe and reliable operation of the propulsion system.

6.5.5 Where continuous operation of the lubricating oil system is essential for the pod to operate at its maximum continuous rating, a standby pump in accordance with *Pt 5, Ch 14, 8.2 Pumps 8.2.2* is to be provided. In such systems, provision is to be made for the efficient filtration of the oil. The filters are to be capable of being cleaned without stopping the pod.

6.5.6 Where bearings are grease lubricated, means are to be provided for collecting waste grease to enable analysis for particulates and water. The arrangements for collecting waste grease are to be in accordance with the pod manufacturer's recommendations. Alternative arrangements which demonstrate that bearings are satisfactorily lubricated will be considered.

6.5.7 Pipework conveying lubricating oil is to be sited such that any possible leakage from joints will not impinge on electrical equipment, hot surfaces or other sources of ignition, see also *Pt 5, Ch 13, 2.9 Miscellaneous requirements 2.9.3*

6.5.8 The procedures for flushing the lubrication system are to be defined. This procedure is to embrace the following conditions:

- (a) Initial installation.
- (b) Post maintenance situations.
- (c) Major dry-docking refits.

See *Pt 5, Ch 9, 10 Installation, maintenance and replacement procedures*.

6.6 Steering system

6.6.1 The requirements of *Pt 5, Ch 19 Steering Arrangements*, Sections *Pt 5, Ch 19, 1 General*, *Pt 5, Ch 19, 2 Performance*, *Pt 5, Ch 19, 3 Construction and design*, *Pt 5, Ch 19, 6 Emergency power*, *Pt 5, Ch 19, 7 Testing and trials* and *Pt 5, Ch 19, 8 Additional requirements* are to be complied with where applicable. See also *Pt 5, Ch 9, 3.1 General*. The requirements of *Pt 5, Ch 19, 2.1 General 2.1.2* and *Pt 5, Ch 19, 2.1 General 2.1.2* are addressed by *Pt 5, Ch 9, 3.1 General 3.1.2* and the requirements of *Pt 5, Ch 19, 2.1 General 2.1.3* and *Pt 5, Ch 19, 2.1 General 2.1.3* are addressed by *Pt 5, Ch 19, 3.1 General 3.1.4*.

6.6.2 For vessels where a single podded propulsion unit is the sole means of propulsion, the requirement for auxiliary steering arrangements in *Pt 5, Ch 19, 2 Performance* is to be achieved by means of two or more identical power units.

6.6.3 For vessels with more than one steerable podded propulsion unit, the requirement for auxiliary steering arrangements in *Pt 5, Ch 19, 2 Performance* is to be achieved by equipping each of the podded propulsion units with its own dedicated and independent steering gear control system and power actuating system. Consideration will be given to alternative arrangements providing equivalence can be demonstrated.

6.6.4 Steering arrangements, other than of the hydraulic type, may be accepted provided that there are means of limiting the maximum torque to which the steering arrangement may be subjected.

6.6.5 The steering mechanism is to be provided with power that is sufficient for the maximum steering torques present during the declared functional capability identified in *Pt 5, Ch 9, 3.1 General* and is to be demonstrated for the most onerous specified manoeuvring trial, see *Pt 5, Ch 9, 9 Testing and trials*.

6.6.6 Geared arrangements employed for steering are to consider the following conditions:

- A design maximum dynamic duty steering torque, M_z , see *Pt 5, Ch 9, 2.4 Global loads 2.4.1*;
- A static duty ($\leq 10^3$ load cycles) steering torque. The static duty steering torque should not be less than M_w , the maximum torque which can be generated by the steering gear mechanism.

The minimum factors of safety, as derived using ISO 6336 Calculation of load capacity of spur and helical gears, or a recognised National Standard, are to be 1.5 on bending stress and 1,0 on Hertzian contact stress. The use of a duty factor in the dynamic duty strength calculations is acceptable but the derivation of such a factor, based on percentage of time spent at a percentage of the maximum working torque, should be submitted to LR for consideration and acceptance.

6.6.7 Slewing ring bearing capacity calculations are to take account of:

- Pod weight in water;
- Gyroscopic forces from the propeller and motor;
- Hydrodynamic loads on pod; and
- Forces due to ship's motions.

The calculations are to demonstrate that the factor of safety against the maximum combination of the above forces is not less than 2. The calculations are to be carried out in accordance with a suitable declared standard.

6.6.8 Means of allowing the condition of the slewing gears and bearings to be assessed are to be provided.

6.6.9 On multi podded ships, means are to be provided to secure each pod unit's slewing mechanism in its mid position in the event of a steering system failure. These arrangements are to be of sufficient strength to hold the pod in position at the ship's manoeuvring speed to be taken as not less than 7 knots, see also *Pt 5, Ch 9, 6.3 Propulsion shafting 6.3.9*. Operating instructions displayed at the securing mechanism's operating position are to include a direction to inform the bridge of any limitation in ship's speed required as a result of the securing mechanism being activated.

6.7 Ventilation and cooling systems

6.7.1 Means are to be provided to ensure that air used for motor cooling purposes is of a suitable temperature and humidity as well as being free from harmful particles.

6.7.2 Cooling water supplies are to comply with *Pt 5, Ch 14, 7 Engine cooling water systems*. See also *Pt 6, Ch 2, 9.6 Machine enclosure*

6.7.3 On single podded installations, a standby cooling arrangement of the same capacity as the main cooling system, is to be provided and available for immediate use.

6.7.4 For pods having an electric propulsion motor but no active cooling system, heat balance calculations as required by *Pt 5, Ch 9, 2.2 Plans and information to be submitted 2.2.1* are to demonstrate that the pod unit and associated systems are able to function satisfactorily over all operating conditions, see *Pt 5, Ch 1, 3.5 Ambient reference conditions*

6.8 Pod drainage requirements

6.8.1 Unless the electrical installation is suitable for operation in a flooded space, means are to be provided to ensure that leakage from shaft bearings or the propeller seal do not reach the motor windings, or other electrical components. Account is to be taken of cooling air flow circulating within the pod unit.

6.8.2 Where the design of a pod space has a requirement to be maintained in a dry condition, two independent means of drainage are to be provided so that liquid leakage may be removed from the pod unit at all design angles of heel and trim, see *Pt 5, Ch 1, 3.6 Ambient operating conditions*

6.8.3 Pipework conveying leakage from the pod is to be sited such that any leakage from joints will not impinge on electrical equipment, see also *Pt 5, Ch 13, 2.9 Miscellaneous requirements 2.9.3*

6.9 Hydraulic actuating systems

6.9.1 Hydraulic actuating systems are to comply with *Pt 5, Ch 14, 9 Hydraulic systems* and *Pt 5, Ch 19, 3 Construction and design* as applicable.

■ Section 7 Electrical equipment

7.1 General

7.1.1 The electrical installation is to be designed, constructed and installed in accordance with the requirements of *Pt 6, Ch 2 Electrical Engineering*.

7.1.2 Means are to be provided to prevent electrical currents flowing across shaft bearings, which may cause their premature failure.

7.1.3 Steering gear electrical systems are to comply with *Pt 5, Ch 19, 5 Electric power circuits, electric control circuits, monitoring and alarms*.

7.1.4 Details are to be submitted to demonstrate the suitability of cables and busbars intended to operate at temperatures exceeding 95°C, see *Pt 6, Ch 2, 7.2 Busbars 7.2.2* and *Pt 6, Ch 2, 11.4 Operating temperature 11.4.3*.

7.2 Slip rings

7.2.1 Where slip rings are incorporated in the design, the details of the following are to be submitted for consideration:

- (a) temperature rise test reports;
- (b) maximum permitted temperature ratings and design operating temperatures for materials;
- (c) where applicable, arrangements for forced air or liquid cooling;
- (d) for data communication link slip rings, evidence to demonstrate compliance with *Pt 6, Ch 1, 2.11 Data communication links 2.11.3*;
- (e) suitability for use under the conditions of vibration expected to arise in normal operation;
- (f) evidence of satisfactory operation under the normal angles of inclination given in *Pt 6, Ch 2, 1.10 Inclination of ship*;
- (g) cable securing arrangements; and
- (h) evidence of electromagnetic compatibility of control, alarm and safety systems with power circuits.

7.2.2 Where forced cooling is used on slip rings, an alarm is to be initiated to indicate the failure of the forced cooling and it is to be possible to operate the slip ring at a reduced power level defined by the Manufacturer in the event of failure of the forced cooling.

■ Section 8 Control engineering systems

8.1 General

- 8.1.1 Control engineering arrangements are to be in accordance with *Pt 6, Ch 1 Control Engineering Systems*.
- 8.1.2 Steering gear control, monitoring and alarm systems are to comply with *Pt 5, Ch 19, 4 Steering control systems* and *Pt 5, Ch 19, 5 Electric power circuits, electric control circuits, monitoring and alarms*.
- 8.1.3 Steering control is to be provided for podded drives from the navigating bridge and locally.
- 8.1.4 An indication of the angular position of the podded propulsion unit(s) and the magnitude of the thrust is to be provided at each station from which it is possible to control the direction of thrust. This indication is to be independent of the steering control system.
- 8.1.5 Emergency Stop Functions are to be provided at the remote control station(s), independent of the podded drive control system, to stop each podded drive in an emergency. *See also Pt 6, Ch 2, 16.4 Propulsion control 16.4.7.*
- 8.1.6 Where programmable electronic equipment is used to prevent loads exceeding those for which the system has been designed (*see Pt 5, Ch 9, 2.4 Global loads 2.4.3*), then either:
- A fully independent hard wired backup is to be provided; or
 - The software is to be certified in accordance with LR's Software Conformity Assessment System – Assessment Module GEN1 (1994) and have an independent solution showing redundancy with design diversity, etc. *see Pt 6, Ch 1, 2.13 Programmable electronic systems - Additional requirements for essential services and safety critical systems* of the Rules.
- 8.1.7 Where a propulsion system which includes a podded propulsor unit is controlled by a series of interactive and integrated programmable electronic systems, then these are to comply with the requirements of *Pt 6, Ch 1, 2.13 Programmable electronic systems - Additional requirements for essential services and safety critical systems* of the Rules.
- 8.1.8 For electronic control systems and electrical actuating systems, an overall quality plan for sourcing, design, installation and testing is to address the following issues:
- Standard(s) applied.
 - Details of the quality control system applied during manufacture and testing.
 - Details of type approval, type testing or approved type status assigned to the equipment.
 - Details of installation and testing recommendations for the equipment.
 - Details of any local and/or remote diagnostic arrangements where assessment and alteration of control parameters can be made which can affect the operation of the podded propulsor unit.
 - Software lifecycle activities, including configuration management and arrangements for software upgrades.
- 8.1.9 The quality plan referred to in *Pt 5, Ch 9, 8.1 General 8.1.8* to identify the process for verification of the functional outputs from the electronic control systems with particular reference to system integrity, consistency, security against unauthorised changes to software and maintaining the outputs within acceptable tolerances of stated performance for safe and reliable operation of the podded propulsor unit.
- 8.1.10 For the permitted range of operating conditions, the control system is to be capable of protecting the podded propulsor from experiencing mechanical loads that may initiate damage while permitting the desired manoeuvres to take place.

8.2 Monitoring and alarms

8.2.1 The requirements for alarms and monitoring arrangements are to be in accordance with *Pt 5, Ch 19, 5.3 Monitoring and alarms* and *Table 9.8.1 Additional alarms and safeguards for podded propulsion units*. These alarms are in addition to the requirements of *Pt 6, Ch 2, 16 Electric propulsion*.

Table 9.8.1 Additional alarms and safeguards for podded propulsion units

Item	Alarm	Note
Podded drive azimuth angle	—	Indicator, <i>see Pt 5, Ch 9, 8.1 General 8.1.4</i>

Propulsion motors	Power supply failure	To be indicated on the navigating bridge
Propulsion motor power limitation or automatic reduction	Activated	See also Pt 6, Ch 2, 16.4 Propulsion control 16.4.9
Hydraulic oil system pressure	Low	To be indicated on the navigating bridge
Bearing temperature	High	For grease lubricated bearings
Motor temperature	High	See Pt 6, Ch 2, 16.1 General 16.1.3
Lubricating oil supply pressure	Low	If separate forced lubrication for shaft bearings; to be indicated on the navigating bridge
Lubricating oil temperature	High	See also Pt 6, Ch 2, 16.5 Protection of propulsion system 16.5.9
Lubricating oil tank level for motor bearings	Low	
Water in lubricating oil for motor bearings	High	Required for single podded propulsion units only
Motor cooling air inlet temperature	High	
Motor cooling air outlet temperature	High	
Motor cooling air flow	Low	
Shaft bearing vibration monitoring	High	See Pt 5, Ch 9, 6.3 Propulsion shafting 6.3.10. Monitoring is to allow bearing condition to be gauged using trend analysis
Shaft sealing	Failure	See Pt 5, Ch 9, 6.3 Propulsion shafting 6.3.13
Dry space water pump operation	Abnormal	Alarm set to indicate a frequency or duration exceeding that which would normally be expected
Dry space water level	1st stage high	—
	2nd stage high	Propulsion motor is to shut down automatically, See Note
Slip ring forced cooling	Failure	See Pt 5, Ch 9, 7.2 Slip rings 7.2.2

Note The second stage dry space water level high alarm is not needed where the electrical equipment installed within the pod is suitable for operation in flooded spaces, see Pt 5, Ch 9, 6.8 Pod drainage requirements 6.8.1.

8.2.2 Alarms specified in Table 9.8.1 Additional alarms and safeguards for podded propulsion units are to be in accordance with the alarm system specified by Pt 6, Ch 1 Control Engineering Systems, Pt 6, Ch 2 Electrical Engineering, Pt 6, Ch 3 Refrigerated Cargo Installations.

8.2.3 Sensors for control, monitoring and alarm systems required by the Rules and located within the pod are to be duplicated in order that a single sensor failure does not inhibit system functionality.

8.2.4 Pod unit dry space pumping arrangements are to function automatically in the event of a high liquid level being detected in the pod unit.

8.2.5 Spaces intended to be dry are to be provided with arrangements to indicate water ingress in accordance with Pt 5, Ch 9, 8.2 Monitoring and alarms 8.2.6 and Table 9.8.1 Additional alarms and safeguards for podded propulsion units.

8.2.6 The number and location of dry space level detectors are to be such that accumulation of liquids will be detected at all design angles of heel and trim.

8.2.7 Condition monitoring arrangements are not to interface with the operation of safety systems which may cause slow-down or shutdown of the propulsion system. See also Pt 6, Ch 1, 2.6 Bridge control for main propulsion machinery 2.6.8.

■ *Section 9*
Testing and trials

9.1 General

9.1.1 The following requirements are to be complied with:

- *Pt 5, Ch 1, 5.2 Sea trials* for sea trials.
- *Pt 5, Ch 19, 7.2 Trials* for steering trials.

In addition, the functional capability specified in *Pt 5, Ch 9, 3.1 General 3.1.1* is to be demonstrated to the Surveyor's satisfaction.

9.1.2 The actual values of steering torque are to be verified during sea trials to confirm that the design maximum dynamic duty torque has not been exceeded.

9.1.3 Electric motor cooling systems are to be verified, as far as possible, to ensure that they are capable of limiting the extremes of ambient temperature to those specified in *Pt 5, Ch 9, 2.3 Pod internal atmospheric conditions 2.3.1*.

9.1.4 Any trials and testing identified from the FMEA report, see *Pt 5, Ch 9, 2.5 Failure Modes and Effects Analysis (FMEA) 2.5.4* are also to be carried out.

■ *Section 10*
Installation, maintenance and replacement procedures

10.1 General

10.1.1 All podded propulsion units are to be supplied with a copy of the manufacturer's installation and maintenance manual that is pertinent to the actual equipment.

10.1.2 The manual required by *Pt 5, Ch 9, 10.1 General 10.1.1* is to be placed on board and is to contain the following information:

- (a) Description of the podded propulsion unit with details of function and design operating limits. This is also to include details of support systems such as lubrication, cooling and condition monitoring arrangements.
 - (b) Identification of all components together with details of any that have a defined maximum operating life.
 - (c) Instructions for installation of unit(s) on board ship with details of any required specialised equipment.
 - (d) Instructions for commissioning at initial installation and following maintenance.
 - (e) Maintenance and service instructions to include inspection/renewal of bearings, seals, motors, slip rings and other major components. This is also to include component fitting procedures, special environmental arrangements, clearance and push-up measurements and lubricating oil treatment where applicable.
 - (f) Actions required in the event of fault/failure conditions being detected.
 - (g) Precautions to be taken by personnel working during installation and maintenance.
-

Steam Raising Plant and Associated Pressure Vessels

Part 5, Chapter 10

Section 1

Section

- 1 **General requirements**
- 2 **Cylindrical shells and drums subject to internal pressure**
- 3 **Spherical shells subject to internal pressure**
- 4 **Dished ends subject to internal pressure**
- 5 **Conical ends subject to internal pressure**
- 6 **Standpipes and branches**
- 7 **Boiler tubes subject to internal pressure**
- Cross-references**
- 8 **Headers**
- 9 **Flat surfaces and flat tube plates**
- 10 **Flat plates and ends of vertical boilers**
- 11 **Furnaces subject to external pressure**
- 12 **Boiler tubes subject to external pressure**
- 13 **Tubes welded at both ends and bar stays for cylindrical boilers**
- 14 **Construction**
- 15 **Mountings and fittings for cylindrical and vertical boilers, steam generators, pressurised thermal liquid and pressurised hot water heaters**
- 16 **Mountings and fittings for water tube boilers**
- 17 **Hydraulic tests**
- 18 **Control and monitoring**

■ Section 1

General requirements

1.1 Application

1.1.1 The requirements of this Chapter are applicable to fusion welded pressure vessels and their mountings and fittings, for the following uses:

- (a) Production or storage of steam.
- (b) Heating of pressurised hot water above 120°C.
- (c) Heating of pressurised thermal liquid.

The formulae in this Chapter may be used for determining the thickness of seamless pressure vessels using a joint factor of 1,0. Seamless pressure vessels are to be manufactured and tested in accordance with the requirements of *Ch 5 Steel Forgings* of the *Rules for the Manufacture, Testing and Certification of Materials* (hereinafter referred to as the Rules for Materials).

1.1.2 The scantlings of coil type heaters with pumped circulation, which are fired or heated by exhaust gas, are to comply with the appropriate requirements of this Chapter.

1.1.3 Where exhaust gas emissions abatement equipment is fitted to steam raising plant, it is to meet the requirements of *Pt 5, Ch 24 Emissions Abatement Plant for Combustion Machinery*.

Steam Raising Plant and Associated Pressure Vessels

Part 5, Chapter 10

Section 1

1.2 Definition of symbols

1.2.1 The symbols used in the various formulae in *Pt 5, Ch 10, 2 Cylindrical shells and drums subject to internal pressure to Pt 5, Ch 10, 8 Headers*, unless otherwise stated, are defined as follows and are applicable to the specific part of the pressure vessel under consideration:

d = diameter of hole or opening, in mm

p = design pressure, see *Pt 5, Ch 10, 1.3 Design pressure*, in bar

r_i = inside knuckle radius, in mm

r_o = outside knuckle radius, in mm

s = pitch, in mm

t = minimum thickness, in mm

D_i = inside diameter, in mm

D_o = outside diameter, in mm

J = joint factor applicable to welded seams, see *Pt 5, Ch 10, 1.9 Joint factors*, or ligament efficiency between tube holes (expressed as a fraction, see *Pt 5, Ch 10, 2.2 Efficiency of ligaments between tube holes*)

R_i = inside radius, in mm

R_o = outside radius, in mm

T = design temperature, in °C

σ = allowable stress, see *Pt 5, Ch 10, 1.8 Allowable stress*, in N/mm².

1.2.2 Where reference is made to calculated or actual plate thickness for the derivation of other values, these thicknesses are to be minus the standard Rule corrosion allowance of 0,75 mm, if not so stated.

1.3 Design pressure

1.3.1 The design pressure is the maximum permissible working pressure and is to be not less than the highest set pressure of any safety valve.

1.3.2 The calculations made to determine the scantlings of the pressure parts are to be based on the design pressure, adjusted where necessary to take account of pressure variations corresponding to the most severe operational conditions.

1.3.3 It is desirable that there should be a margin between the normal pressure at which the boiler or pressure vessel operates and the lowest pressure at which any safety valve is set to lift, to prevent unnecessary lifting of the safety valve.

1.4 Metal temperature

1.4.1 The metal temperature, T , used to evaluate the allowable stress, σ , is to be taken as the actual mean wall metal temperature expected under operating conditions for the pressure part concerned, and is to be stated by the manufacturer when plans of the pressure parts are submitted for consideration.

1.4.2 The following values are to be regarded as the minimum:

- (a) For fired steam boilers, T , is to be taken as not less than 250°C.
- (b) For steam heated generators, secondary drums of double evaporation boilers, steam receivers and pressure parts of fired pressure vessels, not heated by hot gases and adequately protected by insulation, T , is to be taken as the maximum temperature of the internal fluid.
- (c) For pressure parts heated by hot gases, T , is to be taken as not less than 25°C in excess of the maximum temperature of the internal fluid.

Steam Raising Plant and Associated Pressure Vessels **Part 5, Chapter 10**

- (d) For boiler, superheater, reheater and economiser tubes, T , is to be taken as indicated in *Pt 5, Ch 10, 7.1 Minimum thickness 7.1.2*.
- (e) For combustion chambers of the type used in horizontal wet-back boilers, T , is to be taken as not less than 50°C in excess of the maximum temperature of the internal fluid.
- (f) For furnaces, fireboxes, rear tube plates of dry-back boilers and pressure parts subject to similar rates of heat transfer, T , is to be taken as not less than 90°C in excess of the maximum temperature of the internal fluid.

1.4.3 In general any parts of boiler drums or headers not protected by tubes, and exposed to radiation from the fire or to the impact of hot gases, are to be protected by a shield of good refractory material or by other approved means.

1.4.4 Drums and headers of thickness greater than 35 mm are not to be exposed to combustion gases having an anticipated temperature in excess of 650°C unless they are efficiently cooled by closely arranged tubes.

1.5 Classification of fusion welded pressure vessels

1.5.1 For Rule purposes, pressure vessels with fusion welded seams are graded as Class 1 if they comply with the following conditions:

- (a) For pressure parts of fired steam boilers, fired thermal liquid heaters and exhaust gas heated shell type steam boilers where the design pressure exceeds 3,4 bar.
- (b) For pressure parts of steam heated steam generators and separate steam receivers where the design pressure exceeds 11,3 bar, or where the pressure, in bar, multiplied by the internal diameter of the shell, in mm, exceeds 14 420.

1.5.2 For Rule purposes, pressure vessels with fusion welded seams, used for the production or storage of steam, the heating of pressurised hot water above 120°C or the heating of pressurised thermal liquid not included in Class 1 are graded as Class 2/1 and 2/2.

1.5.3 Pressure vessels which are constructed in accordance with Class 2/1 or Class 2/2 standards (as indicated above) will, if manufactured in accordance with requirements of a superior class, be approved with the scantlings appropriate to that class.

1.5.4 Pressure vessels which have only circumferential fusion welded seams, will be considered as seamless with no class being assigned. Preliminary weld procedure tests and non-destructive examination for the circumferential seam welds should be carried out for the equivalent class as determined by *Pt 5, Ch 10, 1.5 Classification of fusion welded pressure vessels 1.5.1* and *Pt 5, Ch 10, 1.5 Classification of fusion welded pressure vessels 1.5.2*.

1.5.5 In special circumstances relating to service conditions, materials, operating temperature, the carriage of dangerous gases and liquids, etc. it may be required that certain pressure vessels be manufactured in accordance with the requirements of a superior class.

1.5.6 Details of heat treatment, non-destructive examination and routine tests (where required) are given in *Ch 13 Requirements for Welded Construction* of the Rules for Materials.

1.5.7 Hydraulic testing is required for pressure vessels of Class 1, 2/1 and 2/2.

1.6 Plans

1.6.1 Plans of boilers, superheaters and economisers are to be submitted in triplicate for consideration. When plans of water tube boilers are submitted for approval, particulars of the safety valves and their disposition on boilers and superheaters, together with the estimated pressure drop through the superheaters, are to be stated. The pressures proposed for the settings of boiler and superheater safety valves are to be indicated on the boiler plan.

1.6.2 Plans, in triplicate, showing full constructional features of fusion welded pressure vessels and dimensional details of the weld preparation for longitudinal and circumferential seams and attachments, together with particulars of the welding consumables and of the mechanical properties of the materials, are to be submitted before construction is commenced.

1.6.3 Plans, in triplicate, showing details of the air flow through the combustion chamber, boiler furnace and boiler uptake spaces, including measures taken to assure effective purging in all of the spaces, are to be submitted for consideration. See also *Pt 5, Ch 10, 18.3 Main, auxiliary and other boilers* and *Pt 5, Ch 14, 12.2 Thermal fluid heaters*.

1.6.4 Plans, in triplicate, showing all areas of refractory material in the combustion chamber and boiler furnace spaces, are to be submitted for consideration. See *Pt 5, Ch 10, 1.12 Furnace explosion prevention 1.12.1*.

1.6.5 Calculations, in triplicate, showing that a minimum of 4 air changes of the combustion chamber, boiler furnace and boiler uptake spaces will be achieved during automatic purging operations, with details of the forced draft fans and arrangements

Steam Raising Plant and Associated Pressure Vessels **Part 5, Chapter 10**

of air flow from fan intake to flue outlet, are to be submitted for consideration, See *Pt 5, Ch 10, 1.12 Furnace explosion prevention 1.12.1.*

1.6.6 Calculations, in triplicate, are to be submitted showing that the ventilation of machinery spaces containing boilers is adequate for the air consumers within the space with an unimpaired air supply, in accordance with the equipment manufacturer's recommendations, under operating conditions as defined in *Ch 1, Pt 5, Ch 1, 4.4 Ventilation 4.4.2.*

1.7 Materials

1.7.1 Materials used in the construction are to be manufactured and tested in accordance with the requirements of the *Rules for the Manufacture, Testing and Certification of Materials, July 2015.*

1.7.2 The specified minimum tensile strength of carbon and carbon-manganese steel plates, pipes, forgings and castings is to be within the following general limits:

(a) For seamless, Class 1, Class 2/1 and Class 2/2 fusion welded pressure vessels:

340 to 520 N/mm².

(b) For boiler furnaces, combustion chambers and flanged plates:

400 to 520 N/mm².

1.7.3 The specified minimum tensile strength of low alloy steel plates, pipes, forgings and castings is to be within the general limits of 400 to 500 N/mm² and pressure vessels made in these steels are to be either seamless or Class 1 fusion welded.

1.7.4 The specified minimum tensile strength of boiler and superheater tubes is to be within the following general limits:

(a) Carbon and carbon-manganese steels: 320 to 460 N/mm².

(b) Low alloy steels: 400 to 500 N/mm².

1.7.5 Where it is proposed to use materials other than those specified in the *Rules for the Manufacture, Testing and Certification of Materials, July 2015*, details of the chemical compositions, heat treatment and mechanical properties are to be submitted for approval. In such cases the values of the mechanical properties used for deriving the allowable stress are to be subject to agreement by Lloyd's Register (hereinafter referred to as 'LR').

1.7.6 Where a fusion welded pressure vessel is to be made of alloy steel, and approval of the scantlings is required on the basis of the high temperature properties of the material, particulars of the welding consumables to be used, including typical mechanical properties and chemical composition of the deposited weld metal, are to be submitted for approval.

1.8 Allowable stress

1.8.1 The term 'allowable stress', σ , is the stress to be used in the formulae for the calculation of scantlings of pressure parts.

1.8.2 The allowable stress, σ , is to be the lowest of the following values:

$$\sigma = \frac{E_t}{1,5} \quad \sigma = \frac{R_{20}}{2,7} \quad \sigma = \frac{S_R}{1,5}$$

where

E_t = specified minimum lower yield stress or 0,2 per cent proof stress at temperature, T

R_{20} = specified minimum tensile strength at room temperature

S_R = average stress to produce rupture in 100 000 hours at temperature, T

T = metal temperature, see *Pt 5, Ch 10, 1.4 Metal temperature.*

1.8.3 The allowable stress for steel castings is to be taken as 80 per cent of the value determined by the method indicated in *Pt 5, Ch 10, 1.8 Allowable stress 1.8.2*, using the appropriate values for cast steel.

1.8.4 Where steel castings, which have been tested in accordance with the *Rules for the Manufacture, Testing and Certification of Materials, July 2015*, are also subjected to non-destructive tests, consideration will be given to increasing the allowable stress using a factor up to 90 per cent in lieu of the 80 per cent referred to in *Pt 5, Ch 10, 1.8 Allowable stress 1.8.3*. Particulars of the non-destructive test proposals are to be submitted for consideration.

Steam Raising Plant and Associated Pressure Vessels **Part 5, Chapter 10**

Section 1

1.9 Joint factors

1.9.1 The following joint factors are to be used in the equations in *Pt 5, Ch 10, 2 Cylindrical shells and drums subject to internal pressure to Pt 5, Ch 10, 8 Headers*, where applicable. Fusion welded pressure parts are to be made in accordance with *Pt 5, Ch 17 Requirements for Fusion Welding of Pressure Vessels and Piping*.

Class of pressure vessel	Joint factor
Class 1	1,0
Class 2/1	0,85
Class 2/2	0,75

1.9.2 The longitudinal and circumferential joints for all classes of pressure vessels for the purposes of this Chapter are to be butt joints. For typical acceptable methods of attaching dished ends, see *Figure 10.14.1 Typical attachments of dished ends to cylindrical shells*.

1.10 Pressure parts of irregular shape

1.10.1 Where pressure parts are of such irregular shape that it is impracticable to design their scantlings by the application of formulae in *Pt 5, Ch 10, 2 Cylindrical shells and drums subject to internal pressure to Pt 5, Ch 10, 8 Headers*, the suitability of their construction is to be determined by hydraulic proof test of a prototype or by agreed alternative method.

1.11 Adverse working conditions

1.11.1 Where working conditions are adverse, special consideration may be required to be given to increasing the scantlings derived from the formulae. In this connection, where necessary, account should also be taken of any excess of loading resulting from:

- impact loads, including rapidly fluctuating pressures,
- weight of the vessel and normal contents under operating and test conditions,
- superimposed loads such as other pressure vessels, operating equipment, insulation, corrosion-resistant or erosion-resistant linings and piping,
- reactions of supporting lugs, rings, saddles or other types of supports, or
- the effect of temperature gradients on maximum stress.

1.12 Furnace explosion prevention

1.12.1 The design of combustion chamber and furnace arrangements is to incorporate measures to minimise the risk of explosion as far as practicable. Measures are to be taken to prevent the accumulation of flammable gases in spaces which may not effectively be reached by purging air. Measures are to be taken to minimise heat retaining surfaces e.g. refractory which can become sources of ignition in the furnace and uptakes.

1.13 Exhaust gas economiser/boiler arrangements

1.13.1 The design of exhaust gas economisers/boilers of the plain or extended surface fin tube types is to be compatible with the installed engine design parameters. The parameters which influence the build up of soot deposits and overheating such as fuel, exhaust gas temperature and efflux velocity are to be considered in the design of the exhaust gas economiser/boiler for use with the installed engine, in order to minimise the risk of fire and breakdown during operation.

1.13.2 A Design Statement demonstrating compliance with the requirements of *Pt 5, Ch 10, 1.13 Exhaust gas economiser/boiler arrangements 1.13.1* or alternative means of preventing the accumulation of soot or overheating, such as the use of exhaust gas bypass ducting with automatic flap valve arrangements and/or effective soot prevention and cleaning systems, is to be submitted for approval.

■ *Section 2*

Cylindrical shells and drums subject to internal pressure

2.1 Minimum thickness

2.1.1 Minimum thickness, t , of a cylindrical shell is to be determined by the following formula:

$$t = \frac{p R_i}{10 \sigma J - 0,5p} + 0,75 \text{ mm}$$

where

t , p , R_i and σ are defined in *Pt 5, Ch 10, 1.2 Definition of symbols*,

J = efficiency of ligaments between tube holes or other openings in the shell or the joint factor of the longitudinal joints (expressed as a fraction). See *Pt 5, Ch 10, 1.9 Joint factors* or *Pt 5, Ch 10, 2.2 Efficiency of ligaments between tube holes*, whichever applies. In the case of seamless shells clear of tube holes or other openings, $J = 1,0$.

2.1.2 The formula in *Pt 5, Ch 10, 2.1 Minimum thickness 2.1.1* is applicable only where the resulting thickness does not exceed half the internal radius, i.e. where R_o is not greater than $1,5R_i$.

2.1.3 Irrespective of the thickness determined by the above formula, t is to be not less than:

- (a) 6,0 mm for cylindrical shell plates.
- (b) For tube plates, such thickness as will give a minimum parallel seat of 9,5 mm, or such greater width as may be necessary to ensure tube tightness, see *Pt 5, Ch 10, 14.6 Fitting of tubes in water tube boilers*.

2.2 Efficiency of ligaments between tube holes

2.2.1 Where tube holes are drilled in a cylindrical shell in a line or lines parallel to its axis, the efficiency, J , of the ligaments is to be determined as in *Pt 5, Ch 10, 2.2 Efficiency of ligaments between tube holes 2.2.2*, *Pt 5, Ch 10, 2.2 Efficiency of ligaments between tube holes 2.2.3* and *Pt 5, Ch 10, 2.2 Efficiency of ligaments between tube holes 2.2.4*.

2.2.2 **Regular drilling.** Where the distance between adjacent tube holes is constant, see *Figure 10.2.1 Regular drilling*,

$$J = \frac{s - d}{s}$$

where

d = the mean effective diameter of the tube holes, in mm, after allowing for any serrations, counterboring or recessing, or the compensating effect of the tube stub. See *Pt 5, Ch 10, 2.3 Compensating effect of tube stubs* and *Pt 5, Ch 10, 2.4 Unreinforced openings*.

s = pitch of tube holes, in mm.

2.2.3 **Irregular drilling.** Where the distance between centres of adjacent tube holes is not constant, see *Figure 10.2.2 Irregular drilling*:

$$J = \frac{s_1 + s_2 - 2d}{s_1 + s_2}$$

where

d = is as defined in *Pt 5, Ch 10, 2.2 Efficiency of ligaments between tube holes 2.2.2*

s_1 = the shorter of any two adjacent pitches, in mm

s_2 = the longer of any two adjacent pitches, in mm.

2.2.4 When applying the formula in *Pt 5, Ch 10, 2.2 Efficiency of ligaments between tube holes 2.2.3*, the double pitch ($s_1 + s_2$) chosen is to be that which makes J , a minimum, and in no case is s_2 to be taken as greater than twice s_1 .

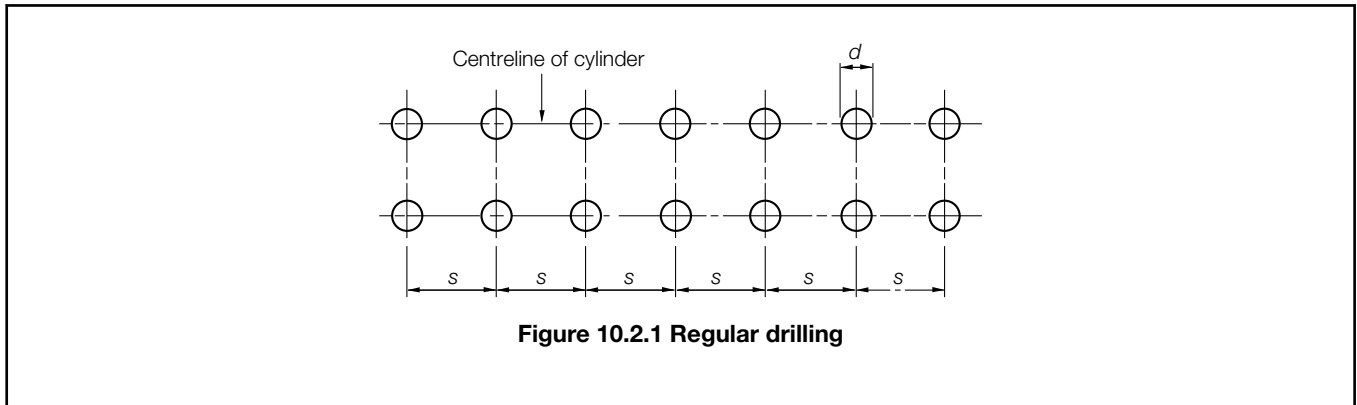

Figure 10.2.1 Regular drilling

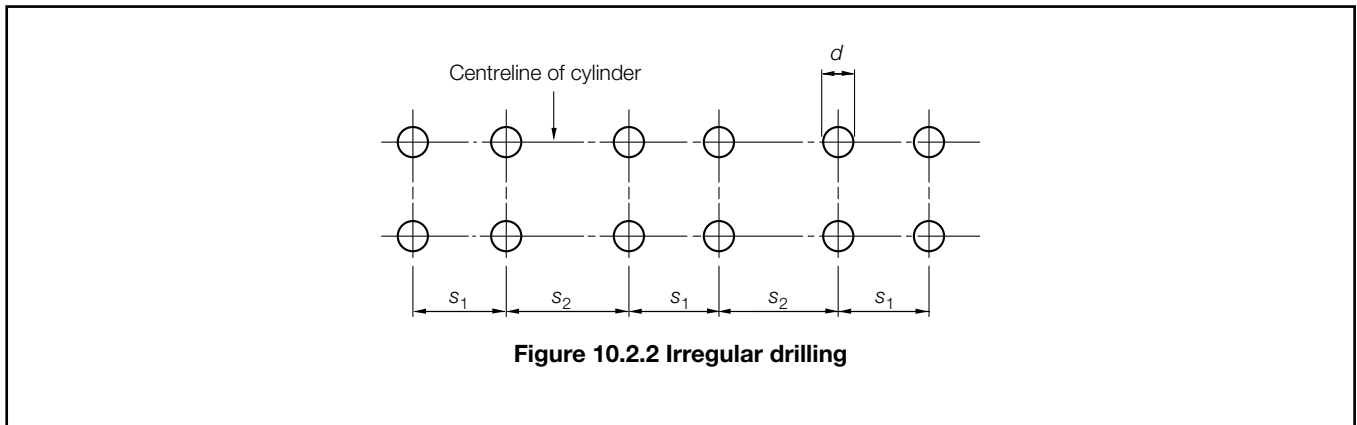

Figure 10.2.2 Irregular drilling

2.2.5 Where the circumferential pitch between tube holes measured on the mean of the external and internal drum or header diameters is such that the circumferential ligament efficiency determined by the formulae in Pt 5, Ch 10, 2.2 Efficiency of ligaments between tube holes 2.2.2 and Pt 5, Ch 10, 2.2 Efficiency of ligaments between tube holes 2.2.3 is less than one-half of the ligament efficiency on the longitudinal axis, J in Pt 5, Ch 10, 2.1 Minimum thickness is to be taken as twice the circumferential efficiency.

2.2.6 Where tube holes are drilled in a cylindrical shell along a diagonal line with respect to the longitudinal axis, the efficiency, J , of the ligaments is to be determined as in Pt 5, Ch 10, 2.2 Efficiency of ligaments between tube holes 2.2.7.

2.2.7 For spacing of tube holes on a diagonal line as shown in Figure 10.2.3 Spacing of holes on a diagonal line, or in a regular saw-tooth pattern as shown in Figure 10.2.4 Regular saw-tooth pattern of holes, J is to be determined from the formula in Pt 5, Ch 10, 2.2 Efficiency of ligaments between tube holes 2.2.8, where a and b , as shown in Figure 10.2.3 Spacing of holes on a diagonal line and Figure 10.2.4 Regular saw-tooth pattern of holes, are measured, in mm, on the median line of the plate, and d , is as defined in Pt 5, Ch 10, 2.2 Efficiency of ligaments between tube holes 2.2.2.

2.2.8 For tube holes on a diagonal line:

$$J = \frac{2}{A + B + \sqrt{(A - B)^2 + 4C^2}}$$

where

$$A = \frac{\cos^2 \alpha + 1}{2\left(1 - \frac{d \cos \alpha}{a}\right)}$$

$$B = 0,5\left(1 - \frac{d \cos \alpha}{a}\right)(\sin^2 \alpha + 1)$$

$$C = \frac{\sin \alpha \cos \alpha}{2\left(1 - \frac{d \cos \alpha}{a}\right)}$$

where

$$\cos \alpha = \frac{1}{\sqrt{1 + \frac{b^2}{a^2}}}$$

$$\sin \alpha = \frac{1}{\sqrt{1 + \frac{a^2}{b^2}}}$$

α = angle between centreline of cylinder and centreline of diagonal holes.

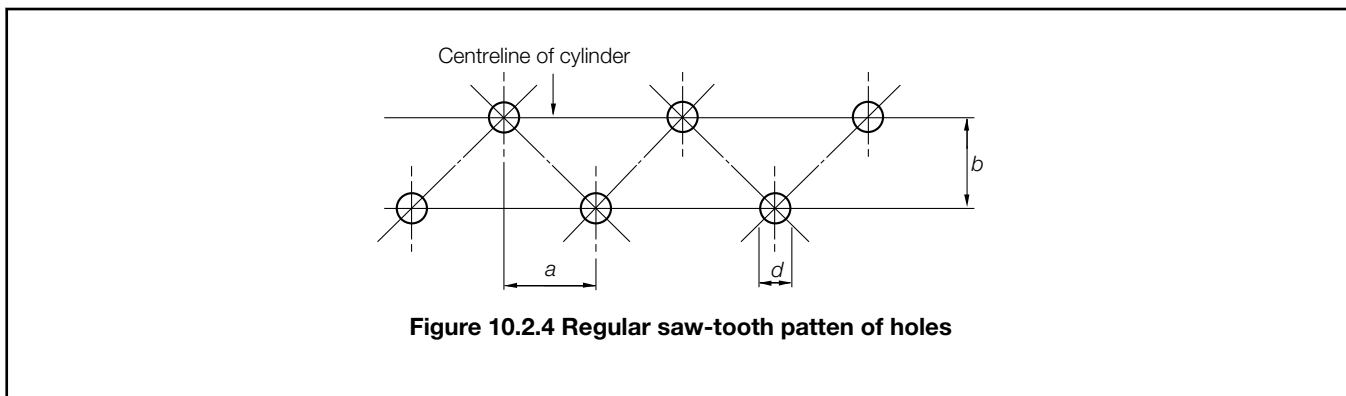
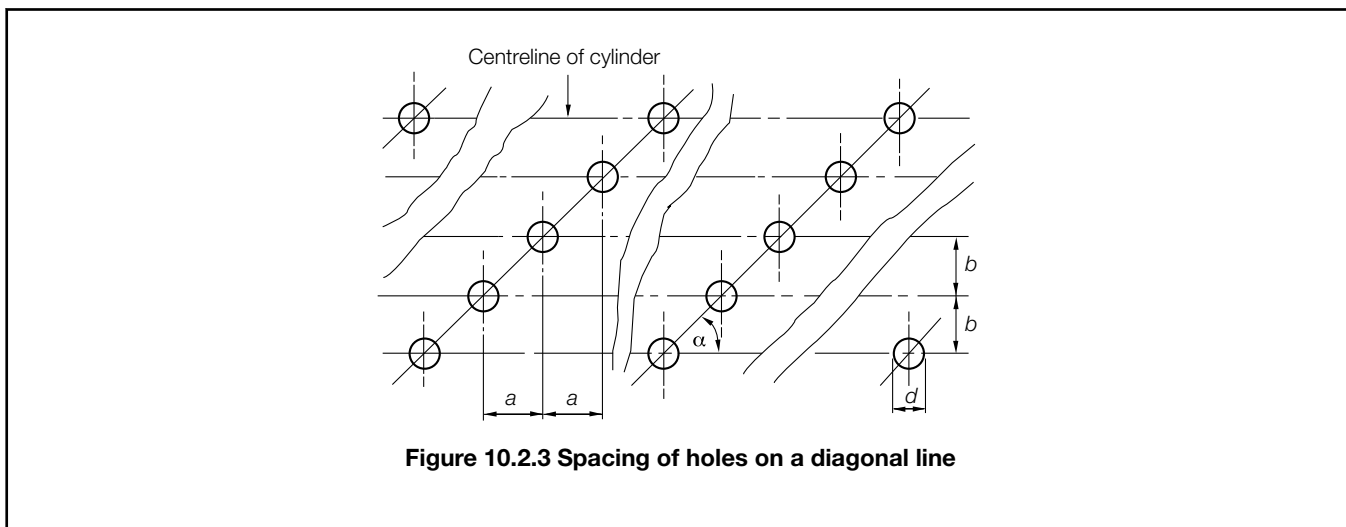

2.2.9 For regularly staggered spacing of tube holes as shown in *Figure 10.2.5 Regular staggering of holes*, the smallest value of the efficiency, J , of all ligaments (longitudinal, circumferential and diagonal) is obtained from *Figure 10.2.7 Compensation of welded tube stubs*. The calculated minimum thickness is to satisfy 7.1, where a and b , as shown in *Figure 10.2.5 Regular staggering of holes*, are measured, in mm, on the median line of the plate, and d is as defined in Pt 5, Ch 10, 2.2 Efficiency of ligaments between tube holes 2.2.2.

2.2.10 For irregularly spaced tube holes whose centres do not lie on a straight line, the formula in Pt 5, Ch 10, 2.2 Efficiency of ligaments between tube holes 2.2.3 is to apply, except that an equivalent longitudinal width of the diagonal ligament is to be used. An equivalent longitudinal width is that width which gives, using the formula in Pt 5, Ch 10, 2.2 Efficiency of ligaments between tube holes 2.2.2, the same efficiency as would be obtained using the formula in Pt 5, Ch 10, 2.2 Efficiency of ligaments between tube holes 2.2.8 for the diagonal ligament in question.

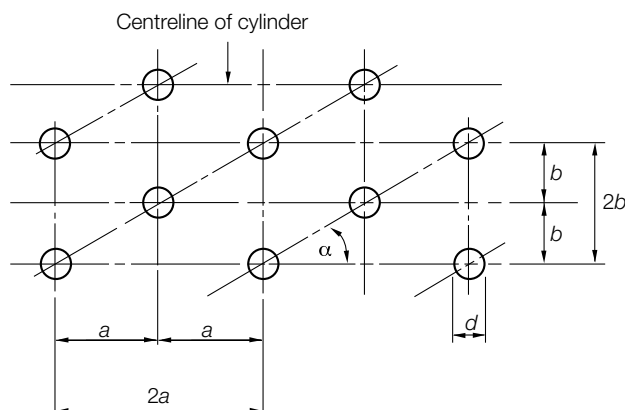

Figure 10.2.5 Regular staggering of holes

2.3 Compensating effect of tube stubs

2.3.1 Where a drum or header is drilled for tube stubs fitted by strength welding, either in line or in staggered formation, the effective diameter of holes is to be taken as:

$$d_e = d_a - \frac{A}{t}$$

where

d_e = the equivalent diameter of the hole, in mm

d_a = the actual diameter of the hole, in mm

t = the thickness of the shell, in mm

A = the compensating area provided by each tube stub and its welding fillets, in mm².

2.3.2 The compensating area, A , is to be measured in a plane through the axis of the tube stub parallel to the longitudinal axis of the drum or header and is to be calculated as follows, see *Figure 10.2.7 Compensation of welded tube stubs* The calculated minimum thickness is to satisfy 7.1 and *Figure 10.2.8 Compensation of welded tube stubs* The calculated minimum thickness is to satisfy 7.1:

- The cross-sectional area of the stub, in excess of that required by Pt 5, Ch 10, 7.1 Minimum thickness for the minimum tube thickness, from the interior surface of the shell up to a distance, b , from the outer surface of the shell;
- plus the cross-sectional area of the stub projecting inside the shell within a distance, b , from the inner surface of the shell;
- plus the cross-sectional area of the welding fillets inside and outside the shell;

where

$$b = \sqrt{d_a t_b}$$

t_b = actual thickness of tube stub, in mm.

2.3.3 Where the material of the tube stub has an allowable stress lower than that of the shell, the compensating cross-sectional area of the stub is to be multiplied by the ratio:

$$\frac{\text{allowable stress of stub at design metal temperature}}{\text{allowable stress of shell at design metal temperature}}$$

Steam Raising Plant and Associated Pressure Vessels Part 5, Chapter 10

Section 2

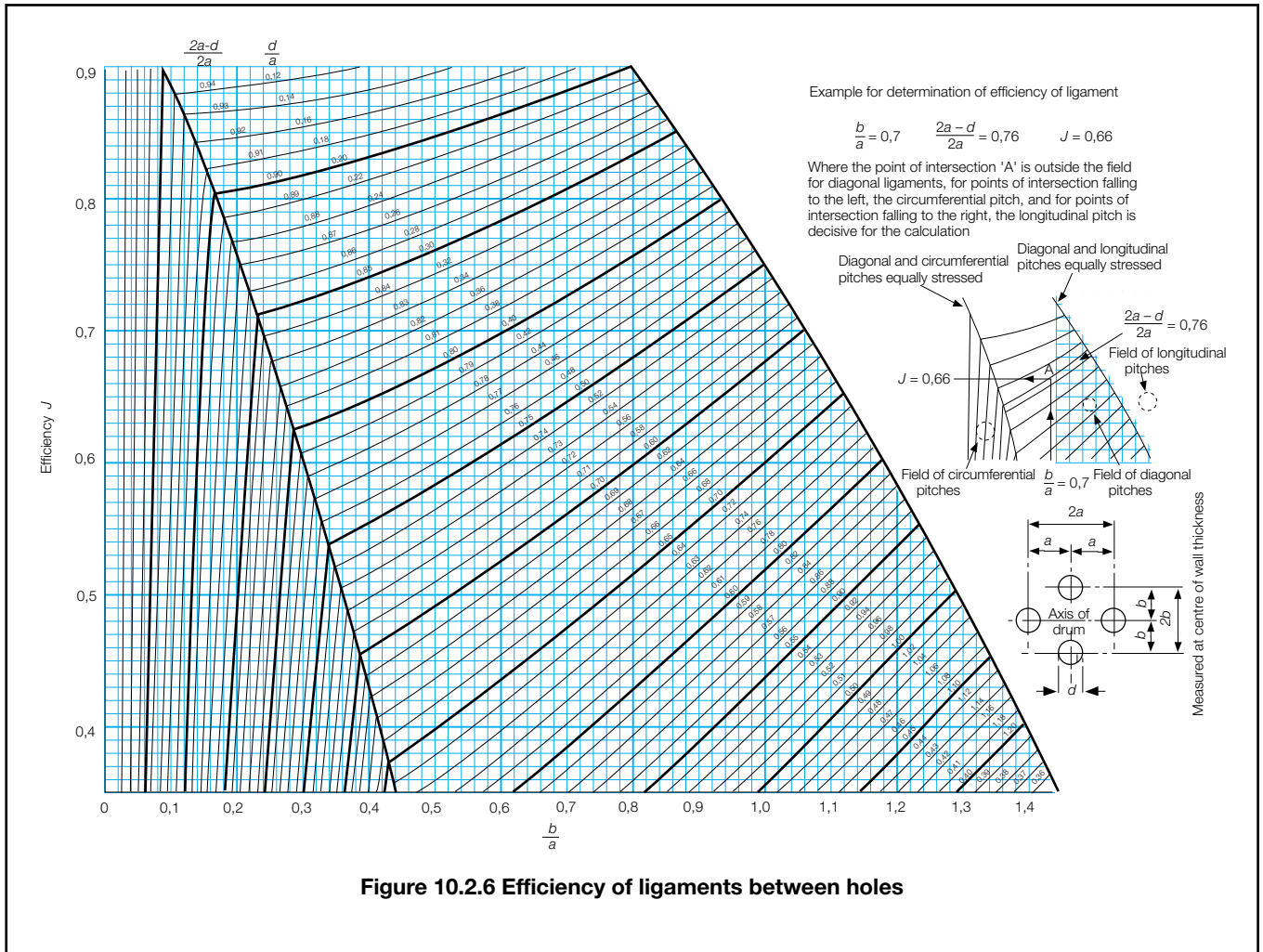

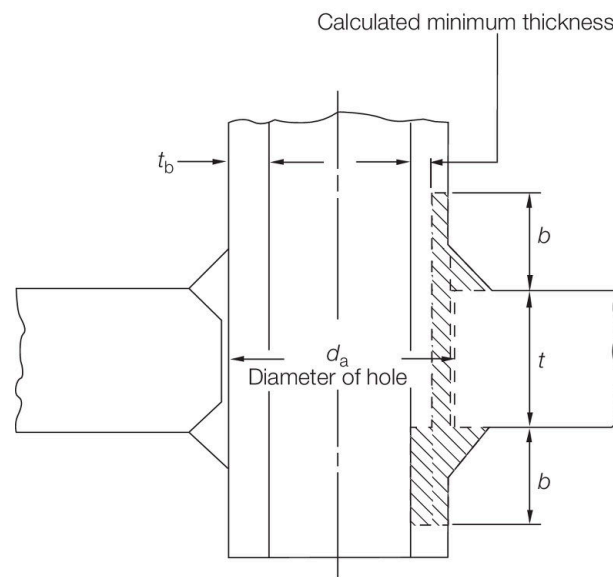

The area shown hatched is half the area A

Figure 10.2.7 Compensation of welded tube stubs

The calculated minimum thickness is to satisfy 7.1

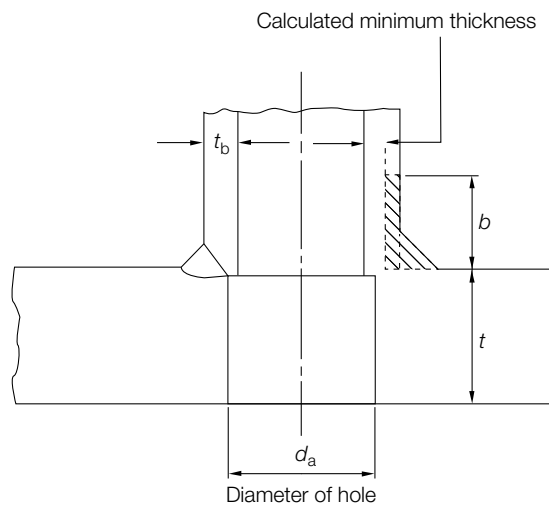

The area shown hatched is half the area A

Figure 10.2.8 Compensation of welded tube stubs

The calculated minimum thickness is to satisfy 7.1

2.4 Unreinforced openings

2.4.1 Openings in a definite pattern, such as tube holes, may be designed in accordance with the Rules for ligaments in *Pt 5, Ch 10, 2.2 Efficiency of ligaments between tube holes*, provided that the diameter of the largest hole in the group does not exceed that permitted by *Pt 5, Ch 10, 2.4 Unreinforced openings 2.4.2*.

2.4.2 The maximum diameter, d , of any unreinforced isolated openings is to be determined by the following formula:

$$d = 8,08 [D_o t (1 - K)]^{1/3} \text{ in mm}$$

The value of K to be used is calculated from the following formula:

$$K = \frac{p D_o}{18,2 \sigma t} \text{ but is not to be taken as greater than } 0,99$$

where

p , D_o and σ are as defined in Pt 5, Ch 10, 1.2 Definition of symbols

t = actual thickness of shell, in mm.

2.4.3 For elliptical or oval holes, d , for the purposes of Pt 5, Ch 10, 2.4 Unreinforced openings 2.4.2, refers to the major axis when this lies longitudinally or to the mean of the major and minor axes when the minor axis lies longitudinally.

2.4.4 No unreinforced opening is to exceed 200 mm in diameter.

2.4.5 Holes may be considered isolated if the centre distance between two holes on the longitudinal axis of a cylindrical shell is not less than:

$$d + 1,1\sqrt{Dt} \text{ with a minimum } 5d$$

where

d = diameter of openings in shell (mean diameter if dissimilarly sized holes involved)

D = mean diameter of shell

t = actual thickness of shell

Where the centre distance is less than so derived, the holes are to be fully compensated.

Where two holes are offset on a diagonal line, the diagonal efficiency from Figure 10.2.6 Efficiency of ligaments between holes may be used to derive an equivalent longitudinal centre distance for the purposes of this paragraph.

2.5 Reinforced openings

2.5.1 Openings larger than those permitted by Pt 5, Ch 10, 2.4 Unreinforced openings are to be compensated in accordance with Figure 10.2.9 Compensation for welded standpipes or branches in cylindrical shells(a) or (b). The following symbols are used in Figure 10.2.9 Compensation for welded standpipes or branches in cylindrical shells(a) and (b):

t_s = calculated thickness of a shell without joint or opening or corrosion allowance, in mm

t_d = thickness calculated in accordance with 7.1 without corrosion allowance, in mm

t_a = actual thickness of shell plate without corrosion allowance, in mm

t_b = actual thickness of standpipe without minus tolerances and corrosion allowance, in mm

t_r = thickness of added reinforcement, in mm

D_i = internal diameter of cylindrical shell, in mm

d_o = diameter of hole in shell, in mm

L = width of added reinforcement not exceeding D , in mm

$$C = \sqrt{d_o t_b} \text{ in mm}$$

$$D = \sqrt{D_i t_a} \text{ and is not to exceed } 0,5d_o, \text{ in mm}$$

σ = shell plate allowable stress, N/mm²

Steam Raising Plant and Associated Pressure Vessels Part 5, Chapter 10

Section 2

σ_p = standpipe allowable stress, N/mm²

σ_r = added reinforcement allowable stress, N/mm²

σ_w = weld metal allowable stress, N/mm²

Note

σ_p , σ_r and σ_w = are not to be taken as greater than σ .

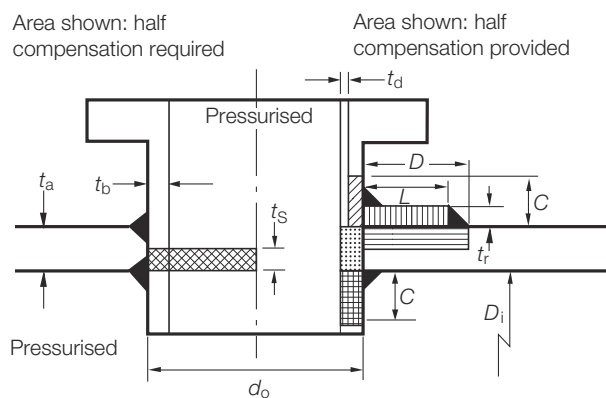

(a) Standpipes or branches

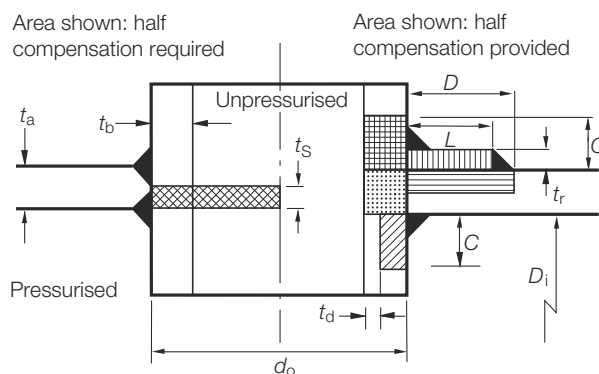

(b) Insert pieces for internal doors

Compensation required:

$$A_1 = \text{[Hatched Area]} = d_o t_s \text{ mm}^2$$

Compensation provided:

$$A_2 = \text{[Horizontal Hatched Area]} = 2D (t_a - t_s) \text{ mm}^2$$

$$A_3 = \text{[Dotted Hatched Area]} = 2 t_b t_a \frac{\sigma_p}{\sigma} \text{ mm}^2$$

$$A_4 = \text{[Grid Hatched Area]} = 2C t_b \frac{\sigma_p}{\sigma} \text{ mm}^2$$

$$A_5 = \text{[Diagonal Hatched Area]} = 2C (t_b - t_d) \frac{\sigma_p}{\sigma} \text{ mm}^2$$

$$A_6 = \text{[Vertical Hatched Area]} = 2L t_r \frac{\sigma_r}{\sigma} \text{ mm}^2$$

$$A_7 = \text{[Triangle Hatched Area]} = (\text{Area of fillet welds}) \frac{\sigma_w}{\sigma} \text{ mm}^2$$

$$A_2 + A_3 + A_4 + A_5 + A_6 + A_7 \geq A_1$$

2865/12

Figure 10.2.9 Compensation for welded standpipes or branches in cylindrical shells

2.5.2 For elliptical or oval holes, the dimension on the meridian of the shell is to be used for d_o in Pt 5, Ch 10, 2.5 Reinforced openings 2.5.1.

2.5.3 Compensation is to be distributed equally on either side of the centreline of the opening.

2.5.4 The welds attaching standpipes and reinforcing plates to the shell are to be of sufficient size to transmit the full strength of the reinforcing areas and all other loadings to which they may be subjected.

■ Section 3 Spherical shells subject to internal pressure

3.1 Minimum thickness

3.1.1 The minimum thickness of a spherical shell is to be determined by the following formula:

$$t = \frac{pR_i}{20\sigma J - 0,5p} + 0,75 \text{ mm}$$

where t , p , R_i , σ and J are as defined in Pt 5, Ch 10, 1.2 Definition of symbols.

3.1.2 The formula in Pt 5, Ch 10, 3.1 Minimum thickness 3.1.1 is applicable only where the resulting thickness does not exceed half the internal radius.

3.1.3 Openings in spherical shells requiring compensation are to comply, in general, with Pt 5, Ch 10, 2.5 Reinforced openings, using the calculated and actual thicknesses of the spherical shell as applicable.

■ Section 4 Dished ends subject to internal pressure

4.1 Minimum thickness

4.1.1 The thickness, t , of semi-ellipsoidal and hemispherical unstayed ends, and the knuckle section of torispherical ends, dished from plate, having pressure on the concave side and satisfying the conditions listed below, is to be determined by the following formula:

$$t = \frac{pD_o K}{20\sigma J} + 0,75 \text{ mm}$$

where

= t , p , D_o , σ and J are as defined in Pt 5, Ch 10, 1.2 Definition of symbols

K = a shape factor, see Pt 5, Ch 10, 4.2 Shape factors for dished ends and Figure 10.4.1 Shape factor.

4.1.2 For semi-ellipsoidal ends:

the external height, $H \geq 0,18 D_o$

where

D_o = the external diameter of the parallel portion of the end, in mm.

4.1.3 For torispherical ends:

the internal radius, $R_i \leq D_o$

the internal knuckle radius, $R_i \geq 0,1 D_o$

the internal knuckle radius, $R_i \geq 3t$

the external height, $H \geq 0,18 D_o$ and is determined as follows:

Steam Raising Plant and Associated Pressure Vessels **Part 5, Chapter 10**

$$H = R_o - \sqrt{(R_o - 0,5D_o)(R_o + 0,5D_o - 2r_o)}$$

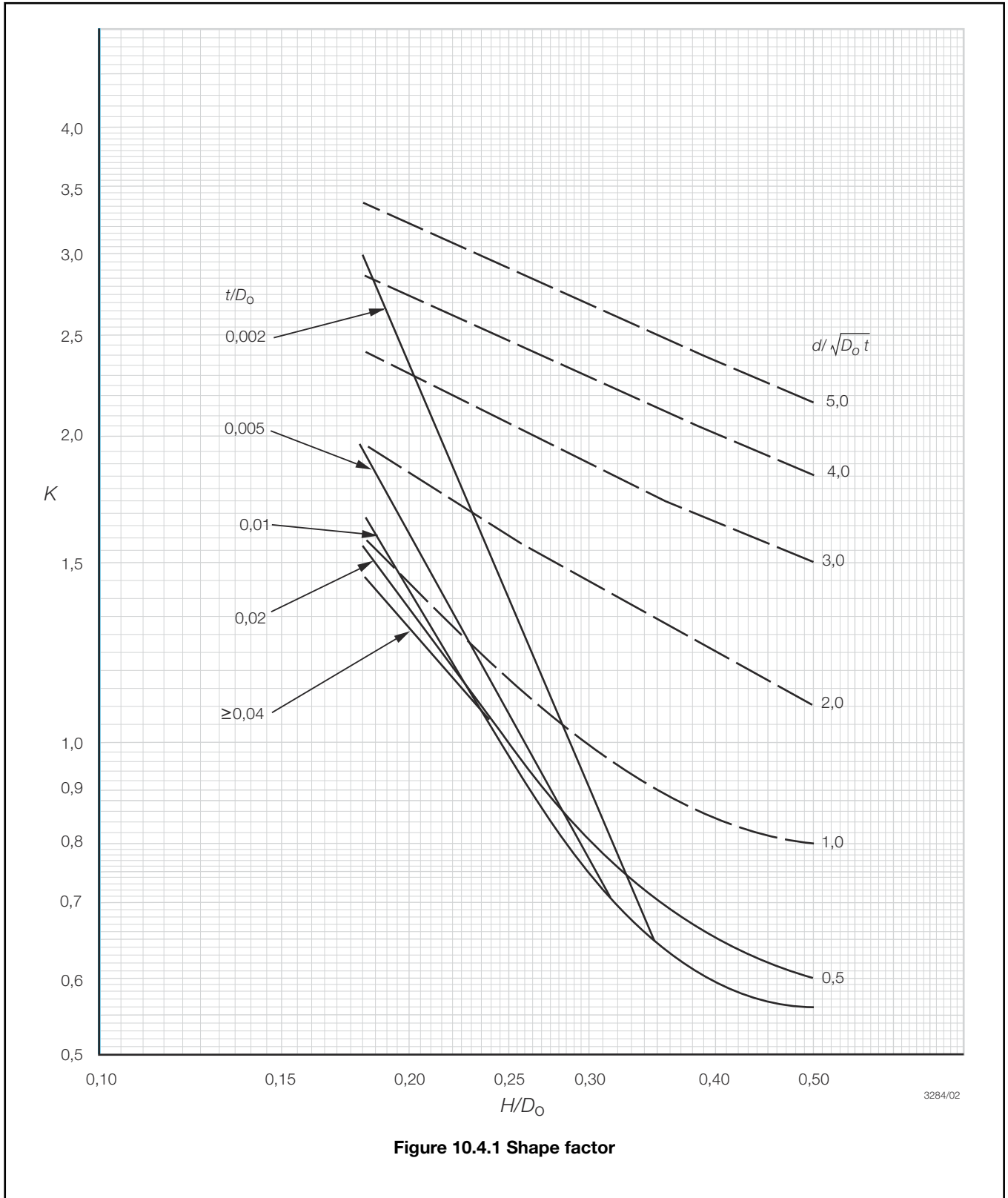

4.1.4 In addition to the formula in Pt 5, Ch 10, 4.1 Minimum thickness 4.1.1 the thickness, t , of a torispherical head, made from more than one plate, in the crown section is to be not less than that determined by the following formula:

$$t = \frac{pR_i}{20\sigma J - 0,5p} + 0,75 \text{ mm}$$

where

t , p , R_i , σ and J are as defined in Pt 5, Ch 10, 1.2 Definition of symbols.

4.1.5 The thickness required by Pt 5, Ch 10, 4.1 Minimum thickness 4.1.1 for the knuckle section of a torispherical head is to extend past the common tangent point of the knuckle and crown radii into the crown section for a distance not less than $0,5\sqrt{R_i t}$ mm, before reducing to the crown thickness permitted by Pt 5, Ch 10, 4.1 Minimum thickness 4.1.4,

where

t = the required thickness from Pt 5, Ch 10, 4.1 Minimum thickness 4.1.1.

4.1.6 In all cases, H , is to be measured from the commencement of curvature, see Figure 10.4.2 Typical dished ends.

4.1.7 The minimum thickness of the head, t , is to be not less than 6,0 mm.

4.1.8 For ends which are butt welded to the drum shell, see Pt 5, Ch 10, 1.8 Allowable stress, the thickness of the edge of the flange for connection to the shell is to be not less than the thickness of an unpierced seamless or welded shell, whichever is applicable, of the same diameter and material and determined by Pt 5, Ch 10, 2.1 Minimum thickness.

4.2 Shape factors for dished ends

4.2.1 The shape factor, K , to be used in Pt 5, Ch 10, 4.1 Minimum thickness 4.1.1 is to be obtained from the curves in Figure 10.4.1 Shape factor, and depends on the ratio of height to diameter $\frac{H}{D_0}$.

4.2.2 The lowest curve in the series provides the factor, K , for plain (i.e. unpierced) ends. For lower values of $\frac{H}{D_0}$, K depends upon the ratio of thickness to diameter, $\frac{t}{D_0}$, as well as on the ratio $\frac{H}{D_0}$, and a trial calculation may be necessary to arrive at the correct value of K .

Steam Raising Plant and Associated Pressure Vessels Part 5, Chapter 10

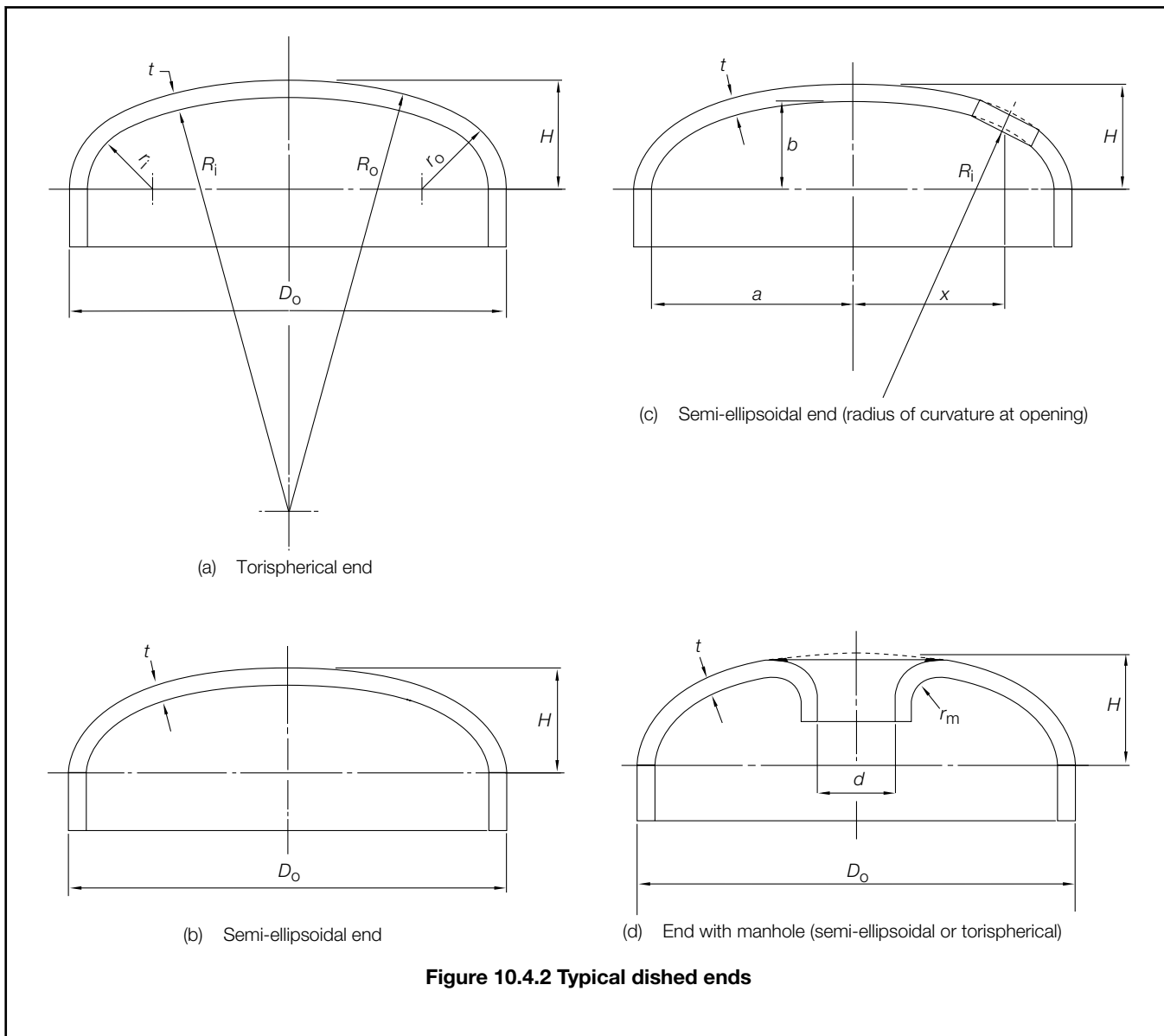

4.3 Dished ends with unreinforced openings

4.3.1 Openings in dished ends may be circular, obround or approximately elliptical.

4.3.2 The upper curves in *Figure 10.4.1 Shape factor* provide values of K , to be used in *Pt 5, Ch 10, 4.1 Minimum thickness 4.1.1*, for ends with unreinforced openings. The selection of the correct curve depends on the value $\frac{d}{\sqrt{D_o t}}$ and trial calculation is necessary to select the correct curve,

where

d = the diameter of the largest opening in the end plate, in mm (in the case of an elliptical opening, the larger axis of the ellipse)

t = minimum thickness, after dishing, in mm

D_o = outside diameter of dished end, in mm.

4.3.3 The following requirements must in any case be satisfied:

$$\frac{t}{D_o} \leq 0,1$$

$$\frac{d}{D_o} \leq 0,7.$$

4.3.4 From *Figure 10.4.1* Shape factor for any selected ratio of $\frac{H}{D_o}$ the curve for unpierced ends gives a value for $\frac{d}{\sqrt{D_o t}}$ as well as for K . Openings giving a value of $\frac{d}{\sqrt{D_o t}}$ not greater than the value so obtained may thus be pierced through an end designed as unpierced without any increase in thickness.

4.4 Flanged openings in dished ends

4.4.1 The requirements in *Pt 5, Ch 10, 4.3 Dished ends with unreinforced openings* apply equally to flanged openings and to unflanged openings cut in the plate of an end. No reduction may be made in end plate thickness on account of flanging.

4.4.2 Where openings are flanged, the radius, r_m of the flanging is to be not less than 25 mm, see *Figure 10.4.2 Typical dished ends*. The thickness of the flanged portion may be less than the calculated thickness.

4.5 Location of unreinforced and flanged openings in dished ends

4.5.1 Unreinforced and flanged openings in dished ends are to be so arranged that the distance from the edge of the hole to the outside edge of the plate and the distance between openings are not less than those shown in *Figure 10.4.3 Opening in dished ends*.

4.6 Dished ends with reinforced openings

4.6.1 Where it is desired to use a large opening in a dished end of less thickness than would be required by *Pt 5, Ch 10, 4.3 Dished ends with unreinforced openings*, the end is to be reinforced. This reinforcement may consist of a ring or standpipe welded into the hole, or of reinforcing plates welded to the outside and/or inside of the end in the vicinity of the hole, or a combination of both methods, see *Figure 10.4.4 Limits of reinforcement*. Forged reinforcements may be used.

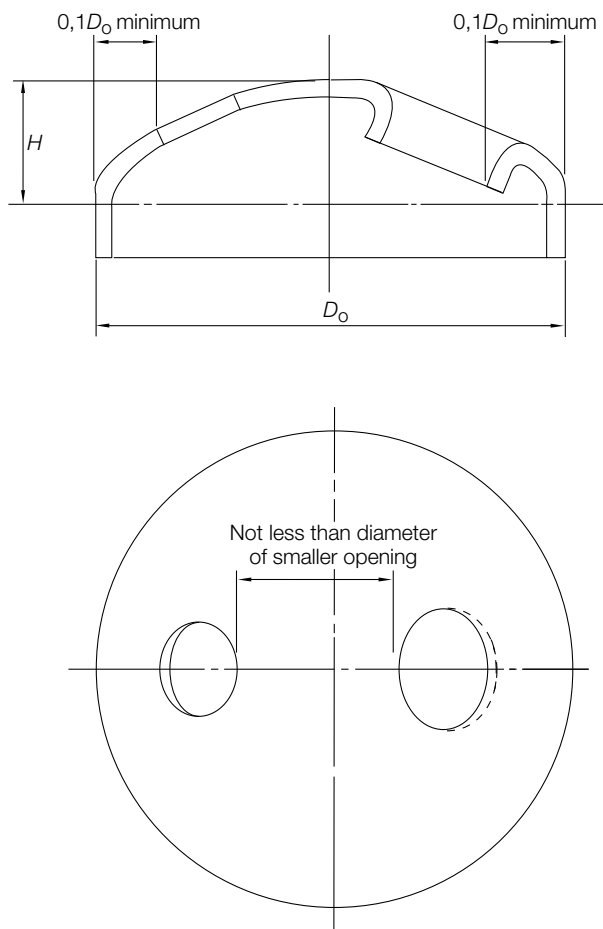
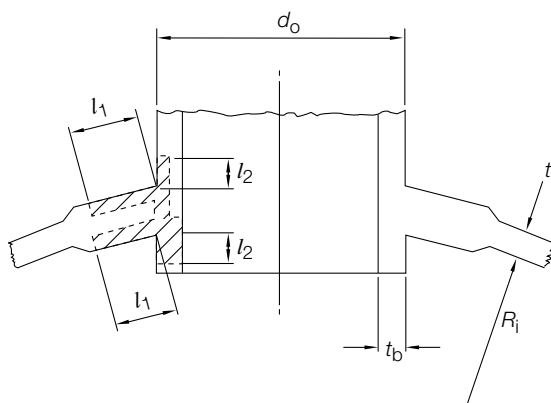

Figure 10.4.3 Opening in dished ends



$$l_1 = \sqrt{2R_i t} \text{ or } 0,5d_o \text{ whichever is the lesser}$$

$$l_2 \text{ is not to exceed } \sqrt{d_o t_b}$$

Figure 10.4.4 Limits of reinforcement

Steam Raising Plant and Associated Pressure Vessels Part 5, Chapter 10

Section 4

4.6.2 Reinforcing material with the following limits may be taken as effective reinforcement:

- (a) The effective width, l_1 of reinforcement is not to exceed $\sqrt{2R_1t}$ or $0,5d_o$ whichever is the lesser.
- (b) The effective length, l_2 of a reinforcing ring is not to exceed $\sqrt{d_o t_b}$

where

R_1 = the internal radius of the spherical part of a torispherical end, in mm, or

R_1 = internal radius of the meridian of the ellipse at the centre of the opening, of a semi-ellipsoidal end, in mm, and is given by the following formula:

$$= \frac{[a^4 - x^2(a^2 - b^2)]^{\frac{3}{2}}}{a^4 b}$$

= where a , b and x are shown in *Figure 10.4.2 Typical dished ends*

d_o = external diameter of ring or standpipe, in mm

l_1 and l_2 = are shown in *Figure 10.4.4 Limits of reinforcement*

t_b = actual thickness of ring or standpipe, in mm.

4.6.3 The shape factor, K , for a dished end having a reinforced opening can be read from *Figure 10.4.1 Shape factor* using the value obtained from:

$$\frac{d_o - \frac{A}{t}}{\sqrt{D_o t}} \text{ instead of from } \frac{d}{\sqrt{D_o t}}$$

where

A = the effective cross-sectional area of reinforcement and is to be twice the area shown shaded on *Figure 10.4.4 Limits of reinforcement*.

As in *Pt 5, Ch 10, 4.3 Dished ends with unreinforced openings*, a trial calculation is necessary in order to select the correct curve.

4.6.4 The area shown in *Figure 10.4.4 Limits of reinforcement* is to be obtained as follows:

- Calculate the cross-sectional area of reinforcement both inside and outside the end plate within the length, l_1
- plus the full cross-sectional area of that part of the ring or standpipe which projects inside the end plate up to a distance, l_2
- plus the full cross-sectional area of that part of the ring or standpipe which projects outside the internal surface of the end plate up to a distance, l_2 and deduct the sectional area which the ring or standpipe would have if its thickness were as calculated in accordance with *Pt 5, Ch 10, 7.1 Minimum thickness*.

4.6.5 If the material of the ring or the reinforcing plates has an allowable stress value lower than that of the end plate, then the effective cross-sectional area, A , is to be multiplied by the ratio:

$$\frac{\text{allowable stress of reinforcing plate at design temperature}}{\text{allowable stress of end plate at design temperature}}$$

4.7 Torispherical dished ends with reinforced openings

4.7.1 If an opening and its reinforcement are positioned entirely within the crown section, the compensation requirements are to be as for a spherical shell, using the crown radius as the spherical shell radius. Otherwise the requirements of *Pt 5, Ch 10, 4.6 Dished ends with reinforced openings* are to be applied.

■ Section 5

Conical ends subject to internal pressure

5.1 General

5.1.1 Conical ends and conical reducing sections, as shown in *Figure 10.5.1 Conical ends and conical reducing sections*, are to be designed in accordance with the equations given in *Pt 5, Ch 10, 5.2 Minimum thickness*.

5.1.2 Connections between cylindrical shell and conical sections and ends should preferably be by means of a knuckle transition radius. Typical permitted details are shown in *Figure 10.5.1 Conical ends and conical reducing sections*. Alternatively, conical sections and ends may be butt welded to cylinders without a knuckle radius where the change in angle of slope, ψ , between the two sections under consideration does not exceed 30°.

5.1.3 Conical ends may be constructed of several ring sections of decreasing thickness, as determined by the corresponding decreasing diameter.

5.2 Minimum thickness

5.2.1 The minimum thickness, t , of cylinder, knuckle and conical section at the junction and within the distance, L , from the junction is to be determined by the following formula:

$$t = \frac{pD_o K}{20 \sigma J} + 0,75 \text{ mm}$$

where

t , p , σ and J are as defined in *Pt 5, Ch 10, 1.2 Definition of symbols*,

K = a factor, taking into account the stress in the knuckle, see *Table 10.5.1 Values of K as a function of ψ and r/D_o* .

D_o = outside diameter, in mm, of the conical section or end, see *Figure 10.5.1 Conical ends and conical reducing sections*.

5.2.2 If the distance of a circumferential seam from the knuckle or junction is not to be less than L , then J is to be taken as 1,0; otherwise J is to be taken as the weld joint factor appropriate to the circumferential seam,

where

L = distance, in mm, from the knuckle or junction within which meridional stresses determine the required thickness, see *Figure 10.5.1 Conical ends and conical reducing sections*

$$= 0,5 \sqrt{\frac{D_o t}{\cos \psi}}$$

r_1 = inside radius of transition knuckle, in mm, which is to be taken as $0,01D_o$ in the case of conical sections without knuckle transition.

ψ = difference between angle of slope of two adjoining conical sections, see *Figure 10.5.1 Conical ends and conical reducing sections*.

Steam Raising Plant and Associated Pressure Vessels Part 5, Chapter 10

Section 5

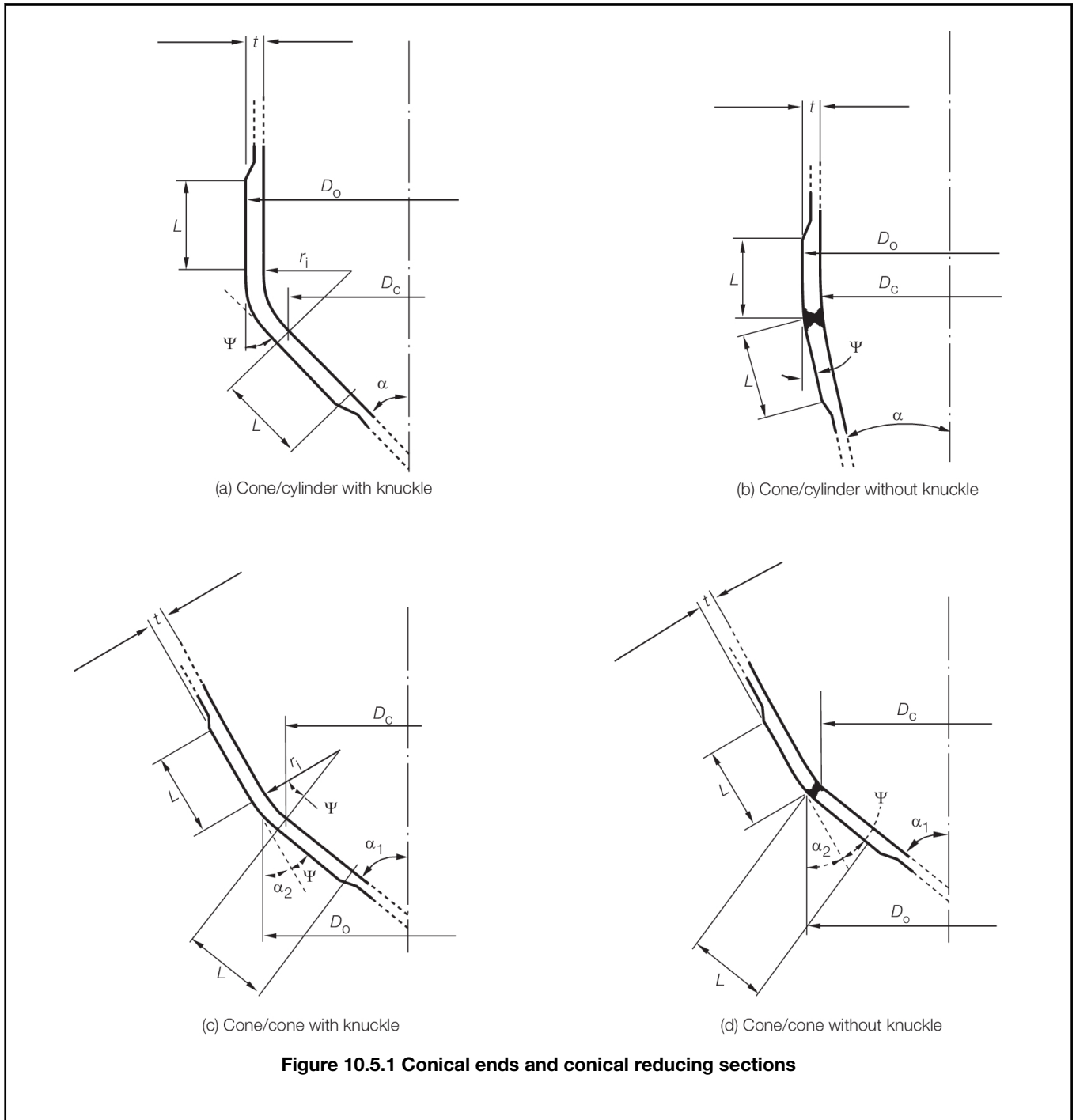

Table 10.5.1 Values of K as a function of ψ and r_i/D_o

ψ	Values of K for r_i/D_o ratios of											
	0,01	0,02	0,03	0,04	0,06	0,08	0,10	0,15	0,20	0,30	0,40	0,50
10°	0,70	0,65	0,60	0,60	0,55	0,55	0,55	0,55	0,55	0,55	0,55	0,55
20°	1,00	0,90	0,85	0,80	0,70	0,65	0,60	0,55	0,55	0,55	0,55	0,55
30°	1,35	1,20	1,10	1,00	0,90	0,85	0,80	0,70	0,65	0,55	0,55	0,55
45°	2,05	1,85	1,65	1,50	1,30	1,20	1,10	0,95	0,90	0,70	0,55	0,55

Steam Raising Plant and Associated Pressure Vessels **Part 5, Chapter 10**

60°	3,20	2,85	2,55	2,35	2,00	1,75	1,60	1,40	1,25	1,00	0,70	0,55
75°	6,80	5,85	5,35	4,75	3,85	3,50	3,15	2,70	2,40	1,55	1,00	0,55

5.2.3 The minimum thickness, t , of those parts of conical sections not less than a distance, L , from the junction with a cylinder or other conical section is to be determined by the following formula:

$$t = \frac{pD_c}{(20\sigma J - p) \cos \alpha} + 0,75 \text{ mm}$$

where

D_c = inside diameter, in mm of conical section or end at the position under consideration, see *Figure 10.5.1 Conical ends and conical reducing sections*

$\alpha, \alpha_1, \alpha_2$ = angle of slope of conical section (at the point under consideration) to the vessel axis, see *Figure 10.5.1 Conical ends and conical reducing sections*.

5.2.4 The greater of the two thicknesses determined by the formulae in *Pt 5, Ch 10, 5.2 Minimum thickness 5.2.1* and *Pt 5, Ch 10, 5.2 Minimum thickness 5.2.3* is to apply at the junction or knuckle and within the limits of reinforcement.

5.2.5 The thickness of conical sections having an angle of inclination to the vessel axis of more than 75° is to be determined as for a flat plate.

■ Section 6 Standpipes and branches

6.1 Minimum thickness

6.1.1 The minimum wall thickness of standpipes and branches is to be not less than that determined by *Pt 5, Ch 10, 7.1 Minimum thickness* increased by the addition of a corrosion allowance of 0,75 mm, making such additions as may be necessary on account of bending, static loads and vibration. The wall thickness, however, is to be not less than:

$$t = 0,015D_o + 3,2 \text{ mm}$$

This thickness need only be maintained for a length, L , from the outside surface of the vessel, but need not extend past the first connection, butt weld or flange, where:

$$L = 3,5\sqrt{D_o t} \text{ mm}$$

where t and D_o are as defined in *Pt 5, Ch 10, 1.2 Definition of symbols*.

6.1.2 For boilers having a working pressure exceeding 50 bar and safety valves of full lift or full bore type, the thickness of the branch pipe carrying the superheater or drum safety valves is to be not less than:

$$t = \frac{1}{\sigma} \left[1,7d + \frac{DWK}{1,3d^2} \right] \text{ mm}$$

= where t and σ are as defined in *Pt 5, Ch 10, 1.2 Definition of symbols*

d = inside diameter of branch, in mm

D = inside diameter of safety valve discharge, in mm

K = 2 for superheater safety valves

= 1 for drum safety valves

W = total valve throughput, in kg/h.

6.1.3 The offset from the centreline of the waste steam pipe to the centreline of the safety valve is not to exceed four times the outside diameter of the safety valve discharge pipe. The waste steam pipe system is to be supported and arrangements made for expansion such that no direct loading is imposed on the safety valve chests and the effects of vibration are to be minimised.

Steam Raising Plant and Associated Pressure Vessels **Part 5, Chapter 10**

6.1.4 The pipe or header which carries the superheater safety valve is to be suitably thickened but is to be not less than the thickness required for the branch for a distance of $\sqrt{D_2 t}$ on either side of the opening,

where

t = thickness required for the branch

D_2 = inside diameter of the pipe or header.

6.1.5 Except as required by *Pt 5, Ch 10, 6.1 Minimum thickness 6.1.4*, in no case need the wall thickness exceed the minimum shell thickness as required by *Pt 5, Ch 10, 2.1 Minimum thickness, Pt 5, Ch 10, 3.1 Minimum thickness or Pt 5, Ch 10, 4.1 Minimum thickness*, as applicable.

6.1.6 Where a standpipe or branch is connected by screwing, the thickness is to be measured at the root of the thread.

6.1.7 For boiler, superheater or economiser tubes, the minimum thickness of the drum or the header connection or tube stub is to be calculated as part of the tube in accordance with *Pt 5, Ch 10, 7.1 Minimum thickness*.

■ Section 7 Boiler tubes subject to internal pressure

7.1 Minimum thickness

7.1.1 The minimum wall thickness of straight tubes subject to internal pressure is to be determined by the following formula:

$$t = \frac{pD_o}{20\sigma + p} \text{ mm}$$

where t , p , D_o and σ are as defined in *Pt 5, Ch 10, 1.2 Definition of symbols*.

Note 1. Provision must be made for minus tolerances where necessary and also in cases where abnormal corrosion or erosion is expected in service. For bending allowances, see *Pt 5, Ch 10, 7.2 Tube bending*.

Note 2. Thickness is in no case to be less than the minimum shown in *Table 10.7.1 Minimum thickness of tubes*.

Table 10.7.1 Minimum thickness of tubes

Normal outside diameter of tube, in mm	Minimum thickness, in mm
≤ 38	1,75
> 38 > 50	2,16
≤ 50 ≤ 70	2,40
> 70 ≤ 75	2,67
> 75 ≤ 95	3,05
>95 ≤ 100	3,28
> 100 ≤ 125	3,50

7.1.2 The minimum thickness of boiler, superheater, reheater and economiser tubes is to be determined by using the design stress appropriate to the mean wall temperature, which will be considered to be the metal temperature. Unless it is otherwise agreed between the manufacturer and LR, the metal temperature used to decide the value of σ for these tubes is to be determined as follows:

- The calculation temperature for boiler tubes is to be taken as not less than the saturated steam temperature, plus 25°C for tubes mainly subject to convection heat, or plus 50°C for tubes mainly subject to radiant heat.
- The calculation temperature for superheater and reheater tubes is to be generally taken as not less than the steam temperature expected in the part being considered, plus 35°C for tubes mainly subject to convection heat. For tubes mainly

Steam Raising Plant and Associated Pressure Vessels **Part 5, Chapter 10**

subject to radiant heat the calculation temperature is generally to be taken as not less than the steam temperature expected in the part being considered, plus 50°C, but the actual metal temperature expected is to be stated when submitting plans.

(c) The calculation temperature for economiser tubes is to be taken as not less than 35°C in excess of the maximum temperature of the internal fluid.

7.1.3 The minimum thickness of downcomer tubes and pipes which form an integral part of the boiler and which are not exposed to combustion gases is to comply with the requirements for steam pipes.

7.2 Tube bending

7.2.1 Where boiler, superheater, reheater and economiser tubes are bent, the resulting thickness of the tubes at the thinnest part is to be not less than that required for straight tubes, unless it can be demonstrated that the method of forming the bend results in no decrease in strength at the bend. The manufacturer is to demonstrate in connection with any new method of tube bending that this condition is satisfied.

7.2.2 Tube bending, and subsequent heat treatment, where necessary, is to be carried out as to ensure that residual stresses do not adversely affect the strength of the tube for the design purpose intended.



Cross-references

For details of manholes, sight holes and doors, see *Pt 5, Ch 10, 14.1 Access arrangements*.

For details of tube holes and fitting of tubes, see *Pt 5, Ch 10, 14.6 Fitting of tubes in water tube boilers*.



Section 8 Headers

8.1 Circular section headers

8.1.1 The minimum thickness of circular section headers is to be calculated in accordance with the formula for cylindrical shells in *Pt 5, Ch 10, 2.1 Minimum thickness*.

8.2 Rectangular section headers

8.2.1 The thickness of the flat walls of rectangular section headers is to be determined at the centre of the sides, at all the lines of holes and at the corners. The minimum required is to be the greatest thickness determined by the following formula:

$$t = \frac{pn}{20 \sigma J} + \sqrt{\frac{0,4Y_p}{\sigma J_1}} + 0,75 \text{ mm}$$

where

n = one half of the internal width of the wall perpendicular to that under consideration, in mm, see *Figure 10.8.1 Rectangular section headers*

J = ligament efficiency for membrane stresses determined in accordance with *Pt 5, Ch 10, 8.2 Rectangular section headers 8.2.3*

J_1 = ligament efficiency for bending stresses determined in accordance with *Pt 5, Ch 10, 8.2 Rectangular section headers 8.2.3*

Y = a coefficient determined in accordance with *Pt 5, Ch 10, 8.2 Rectangular section headers 8.2.2*. In all cases if the value of Y is negative, the sign is to be ignored.

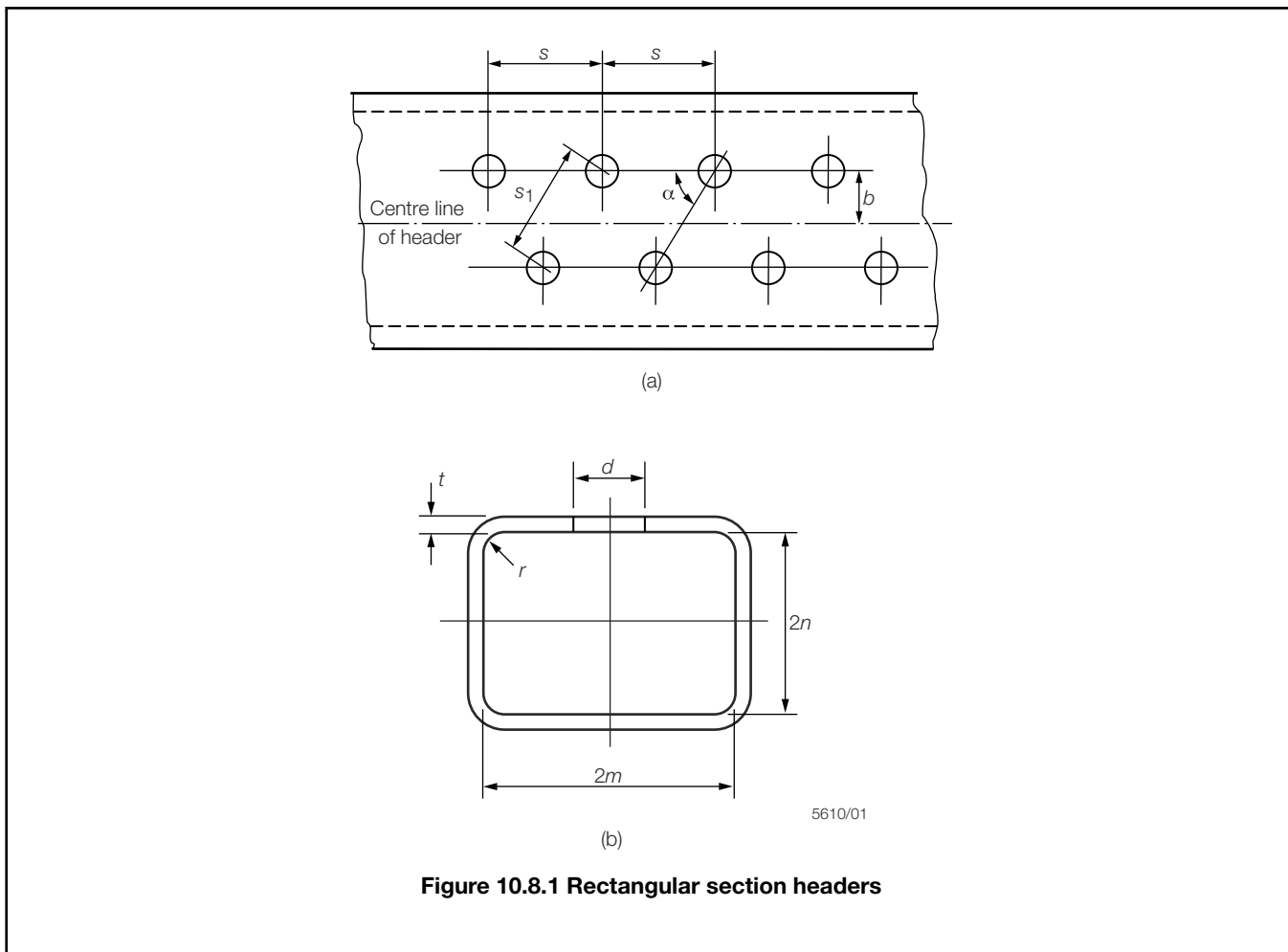

8.2.2 The coefficient Y for use in Pt 5, Ch 10, 8.2 Rectangular section headers 8.2.1 is to be determined as follows:

(a) at the centre of the side with internal width, $2m$:

$$Y = \frac{1}{3} \left(\frac{m^3 + n^3}{m + n} \right) - \frac{1}{2} m^2$$

where

m = one half of the internal width of the wall under consideration, in mm, see Figure 10.8.1 Rectangular section headers

(b) at a line of holes parallel to the longitudinal axis of the header on the wall of width, $2m$:

$$Y = \frac{1}{3} \left(\frac{m^3 + n^3}{m + n} \right) - \frac{m^2 - b^2}{2}$$

where

b = distance from the centre of the holes to the centreline of the wall, in mm, see Figure 10.8.1 Rectangular section headers

(c) to check the effect of the off-set on a staggered hole arrangement where the holes are positioned equidistant from the centreline of the wall:

$$Y = \cos \alpha \left\{ \frac{1}{3} \left(\frac{m^3 + n^3}{m + n} \right) - \frac{m^2}{2} \right\}$$

where

α = the angle subtended by the diagonal ligament on the longitudinal ligament, see *Figure 10.8.1 Rectangular section headers*

(d) at the corners:

$$Y = \frac{1}{3} \left(\frac{m^3 + n^3}{m + n} \right)$$

8.2.3 The ligament efficiencies J and J_1 are to be determined as follows:

(a) for a line of holes parallel to the longitudinal axis of the header:

$$J = \frac{s - d}{s}$$

Symbols are as defined in *Pt 5, Ch 10, 8.2 Rectangular section headers 8.2.4*.

(b) for the diagonals:

$$J = \frac{s_1 - d}{s_1}$$

Symbols are as defined in *Pt 5, Ch 10, 8.2 Rectangular section headers 8.2.4*.

(c) for a line of holes parallel to the longitudinal axis of the header:

$$J_1 = \frac{s - d}{s} \text{ when } d < 0,6m$$

or

$$J_1 = \frac{s - 0,6m}{s} \text{ when } d \geq 0,6m$$

Symbols are as defined in *Pt 5, Ch 10, 8.2 Rectangular section headers 8.2.4*.

(d) for the diagonals:

$$J_1 = \frac{s_1 - d}{s_1} \text{ when } d < 0,6m$$

or

$$J_1 = \frac{s_1 - 0,6m}{s_1} \text{ when } d \geq 0,6m$$

Symbols are as defined in *Pt 5, Ch 10, 8.2 Rectangular section headers 8.2.4*.

8.2.4 Symbols, as used in *Pt 5, Ch 10, 8.2 Rectangular section headers 8.2.3*, are defined as follows:

d = diameter of the hole in the header, in mm

= m , s and s_1 , in mm, are as shown in *Figure 10.8.1 Rectangular section headers*.

8.2.5 In the case of elliptical holes the value of d to be used in the equations for J and J_1 is to be the inside dimension of the hole measured parallel to the longitudinal axis of the header. For evaluating the two limiting values of d in the equations for J_1 , the value of d is to be the inside dimension of the hole measured perpendicular to the longitudinal axis of the header.

8.2.6 The internal corner radius, r , is to be not less than one third of the mean of the nominal thicknesses of the two sides, but in no case to be less than 6,5 mm.

8.3 Toroidal furnace headers

8.3.1 The minimum thickness of a toroidal header forming the lower end of a waterwall furnace, and supporting the weight of the boiler and water, is to be determined by the following formula:

$$t = A + \sqrt{A^2 + \frac{4M}{JS\sigma}} + 0,75 \text{ mm}$$

where

$$A = \frac{pr}{30J\sigma} \text{ mm}$$

= t , p and σ are as defined in Pt 5, Ch 10, 1.2 Definition of symbols

d_e = equivalent diameter of the tube hole in accordance with Pt 5, Ch 10, 2.3 Compensating effect of tube stubs

r = inside radius of toroid circular cross section, in mm, see Figure 10.8.3 Toroidal furnace headers

J = ligament efficiency of tube holes around toroid

$$= \frac{S - d_e}{S}$$

S = pitch of tubes around the toroid, in mm

$$M = \frac{Wr}{3} - \frac{pd^2r}{40} \text{ Nmm}$$

where

W = imposed loading on each water wall tube due to the weight of the boiler and water, in N

d = minimum diameter of the tube hole in the toroid, in mm

The calculation is to be performed at design pressure using the allowable stress at saturation temperature, and also at zero pressure using the allowable stress at 100°C.

8.4 Header ends

8.4.1 The shape and thickness of ends forged integrally with the bodies of headers are to be the subject of special consideration.

8.4.2 Where sufficient experience of previous satisfactory service of headers with integrally forged ends cannot be shown, the suitability of a proposed form of end is to be proved in accordance with the provisions of Pt 5, Ch 10, 1.10 Pressure parts of irregular shape.

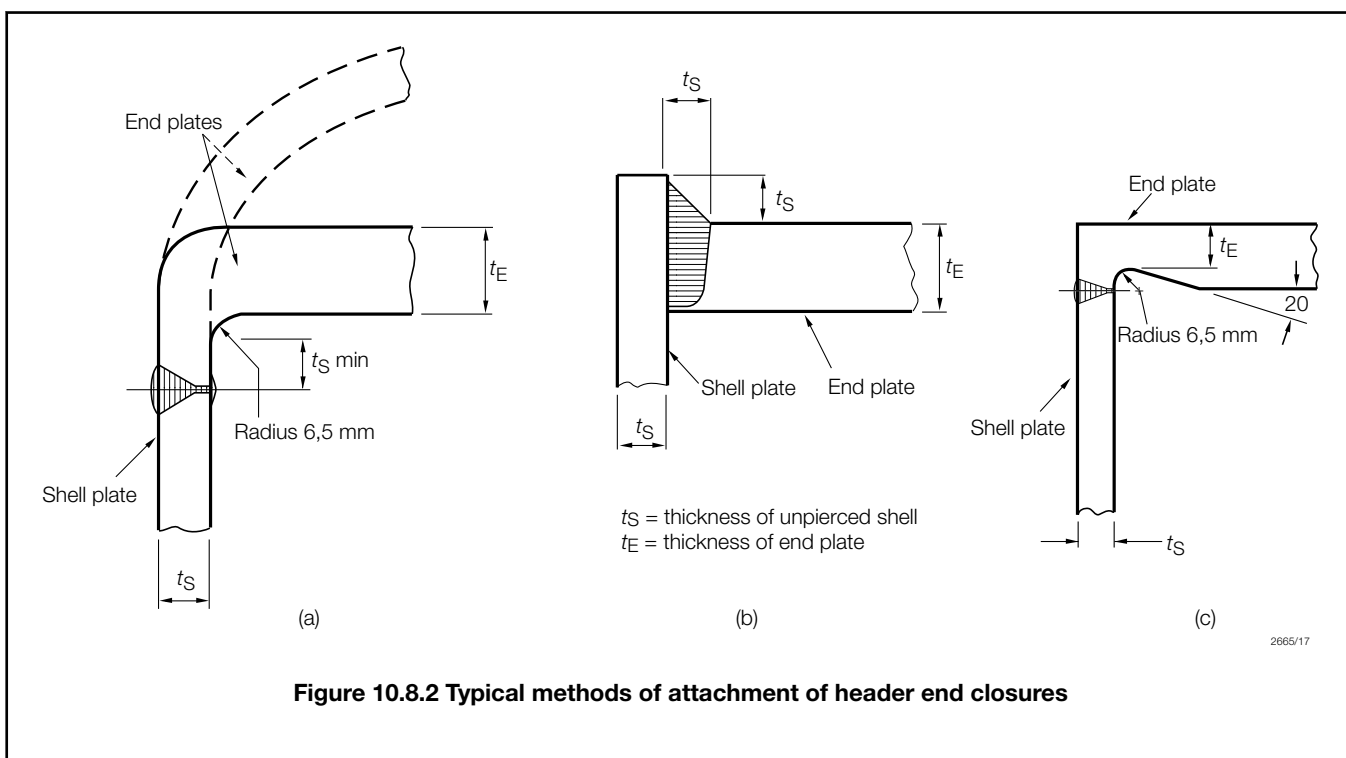

8.4.3 Ends attached by welding are to be designed as follows:

- Dished ends: these are to be in accordance with *Pt 5, Ch 10, 4.1 Minimum thickness*.
- Flat ends: the minimum thickness of flat end plates is to be determined by the following formula:

$$t = d_i \sqrt{\frac{pC}{\sigma}} + 0,75 \text{ mm}$$

= where p and σ are as defined in *Pt 5, Ch 10, 1.2 Definition of symbols*.

t = minimum thickness of end plate, in mm

d_i = internal diameter of circular header or least width between walls of rectangular header, in mm

C = a constant depending on method of end attachment, see *Figure 10.8.2 Typical methods of attachment of header end closures*.

- For end plates welded as shown in *Figure 10.8.2 Typical methods of attachment of header end closures(a)*:

$C = 0,019$ for circular headers

= 0,032 for rectangular headers.

- For end plates welded as shown in *Figure 10.8.2 Typical methods of attachment of header end closures(b) and (c)*:

$C = 0,028$ circular headers

= 0,040 for rectangular headers.

8.4.4 Where flat end plates are bolted to flanges attached to the ends of headers, the flanges and end plates are to be in accordance with recognised pipe flange standards.

8.4.5 Openings in flat plates are to be compensated in accordance with *Figure 10.2.9 Compensation for welded standpipes or branches in cylindrical shells*, with the value of A_1 the compensation required, calculated as follows:

$$A_1 = \frac{d_o}{2,4} t_f \text{ mm}$$

where

d_o = diameter of hole in flat plate, in mm

t_f = required thickness of the flat plate in the area under consideration, in mm, calculated in accordance with *Pt 5, Ch 10, 8.4 Header ends 8.4.3* or *Pt 5, Ch 10, 9.1 Stayed flat surfaces 9.1.6*, as applicable, without corrosion allowance

Limit $D = 0,5 d_o$.

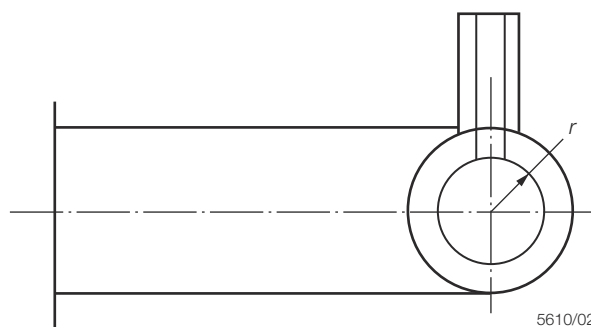

Figure 10.8.3 Toroidal furnace headers

■ Section 9
Flat surfaces and flat tube plates

9.1 Stayed flat surfaces

9.1.1 Where flat end plates are flanged for connection to the shell, the inside radius of flanging is to be not less than 1,75 times the thickness of the plate, with a minimum of 38 mm.

9.1.2 Where combustion chamber or firebox plates are flanged for connection to the wrapper plate, the inside radius of flanging is to be equal to the thickness of the plate, with a minimum of 25 mm.

9.1.3 Where unflanged flat plates are connected to the shell by welding, typical methods of attachment are shown in *Figure 10.9.1 Typical attachment of unflanged flat end plates to shell*. Similar forms of attachment may be used where unflanged combustion chamber or firebox plates are connected to the wrapper plate by welding.

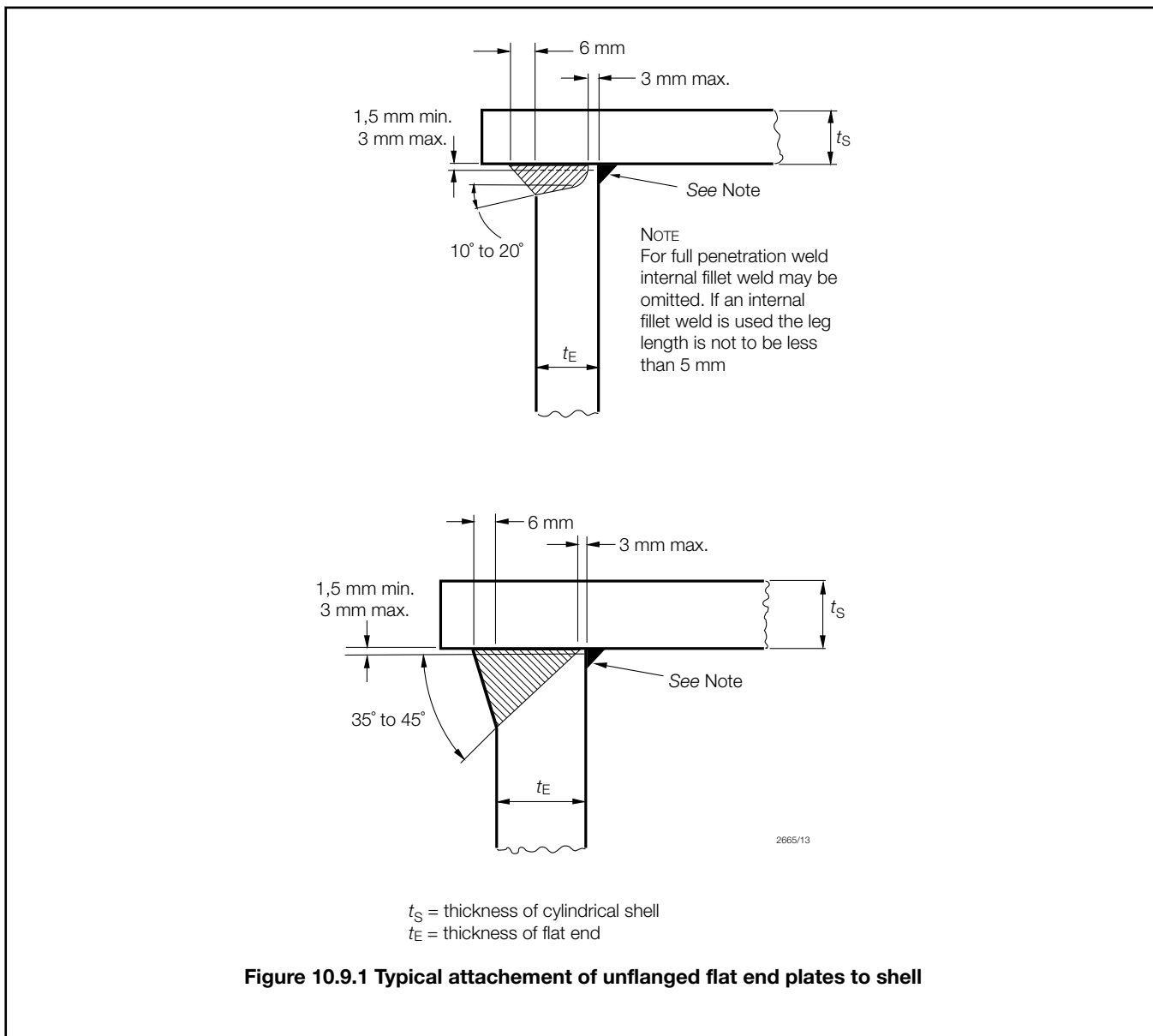

9.1.4 Where the flange curvature is a point of support, this is to be taken at the commencement of curvature, or at a line distant 3,5 times the thickness of the plate from the outside of the plate, whichever is nearer to the flange.

Steam Raising Plant and Associated Pressure Vessels **Part 5, Chapter 10**

9.1.5 Where a flat plate is welded directly to a shell or wrapper plate, the point of support is to be taken at the inside of the shell or wrapper plate.

9.1.6 The thickness, t , of those portions of flat plates supported by stays and around tube nests is to be determined by the following formula:

$$t = Cd\sqrt{\frac{p}{\sigma}} + 0,75 \text{ mm}$$

= where t , p and σ are as defined in Pt 5, Ch 10, 1.2 Definition of symbols

d = diameter of the largest circle which can be drawn through at least three points of support. At least one point of support must lie on one side of any diameter of the circle

C = a constant, dependent on the method of support as detailed in Pt 5, Ch 10, 9.1 Stayed flat surfaces 9.1.7. Where various forms of support are used, C is to be the mean of the values for the respective methods adopted.

9.1.7 The value of C in the formula in Pt 5, Ch 10, 9.1 Stayed flat surfaces 9.1.6 is to be as follows:

(a) Where plain bar stays are strength welded into the plates as shown in Figure 10.9.2 Typical attachment of firebox, combustion chamber stays and bar stays

$$C = 0,134$$

(b) Where plain bar stays pass through holes in the plates and are fitted on the outside with washers as shown in Figure 10.9.3 Typical attachment of bar stays

$$C = 0,12 \text{ where the diameter of the washer is 3,5 times the diameter of the stay}$$

$$C = 0,113 \text{ where the diameter of the washer is 0,67 times the pitch of the stays.}$$

(c) Where the flat plate is flanged for attachment to the shell, flue, furnace or wrapper or, alternatively, is welded directly to shell, flue, furnace or wrapper, see Pt 5, Ch 10, 9.1 Stayed flat surfaces 9.1.4 and Pt 5, Ch 10, 9.1 Stayed flat surfaces 9.1.5:

$$C = 0,113$$

(d) Where the support is a gusset stay

$$C = 0,134$$

(e) Where the support is a tube secured as shown in Figure 10.9.4 Detail of weld for tube

$$C = 0,144.$$

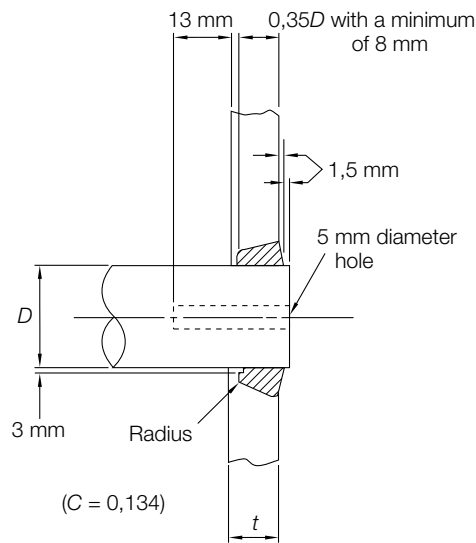
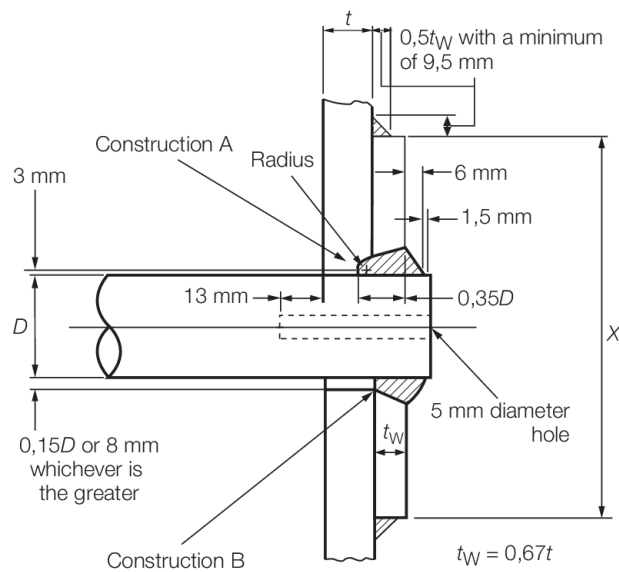

Figure 10.9.2 Typical attachment of firebox, combustion chamber stays and bar stays



Method of construction 'A' or 'B' may be used, except where $t_W < 0,35D$, construction 'A' is to be used.

where $X=3,5D$, $C=0,12$;
where $X=0,67 \times \text{pitch of stays}$, $C=0,113$

Figure 10.9.3 Typical attachment of bar stays

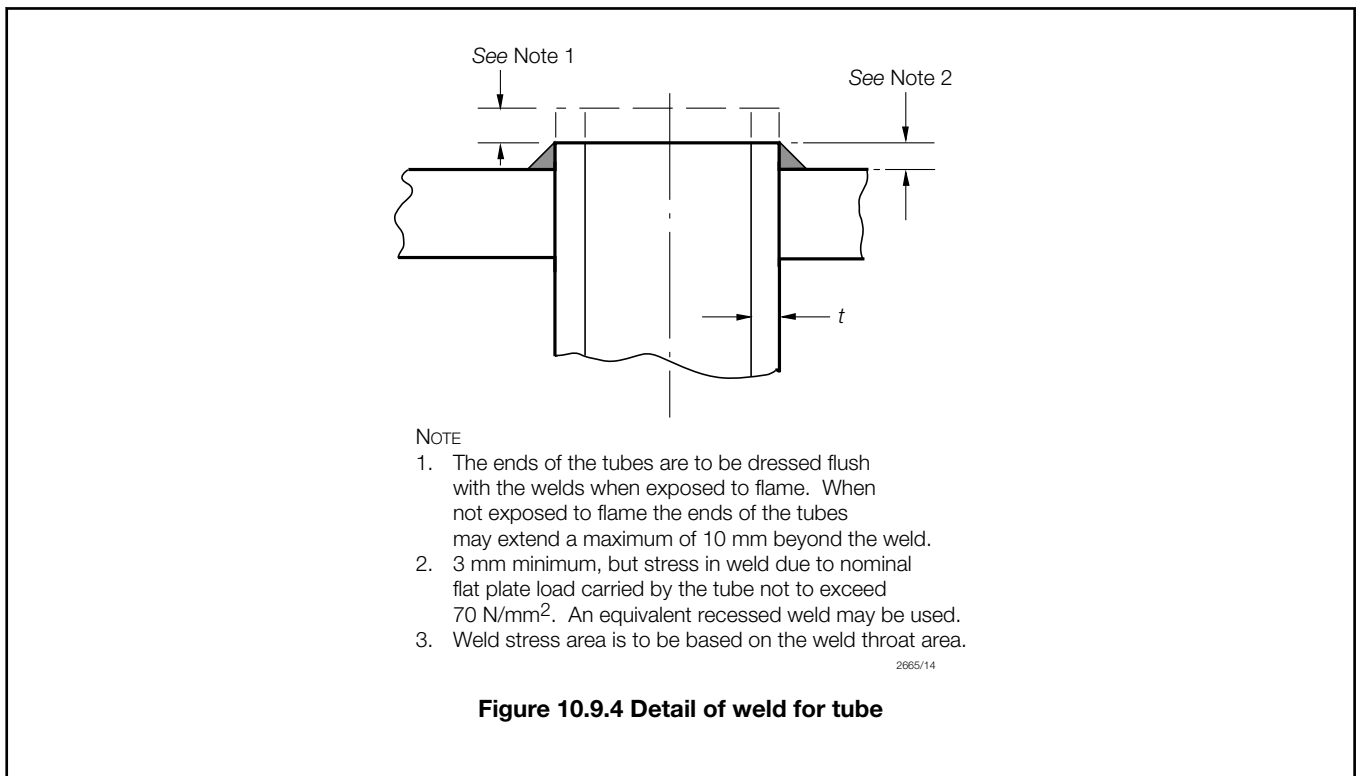

9.1.8 Where tubes are fixed by expanding only, sufficient tubes welded at both ends in accordance with *Figure 10.9.4 Detail of weld for tube* are to be provided within the tube nest to comply with *Pt 5, Ch 10, 9.1 Stayed flat surfaces 9.1.6*, to carry the flat plate loading within the tube nest. Tubes welded in accordance with *Figure 10.9.4 Detail of weld for tube* are also to be provided in the boundary rows in sufficient numbers to carry the flat plate loading outside the tube areas.

9.1.9 In the case of small boilers with a single tube nest of expanded tubes which does not exceed an area of 0,65 m², welded tubes need not be fitted provided the tubes are beaded at the inlet end. In this instance the support afforded by the expanded tubes is not to be taken to extend beyond the line enclosing the outer surfaces of the tubes except that, between the outside of the nest and the attachment of the end plate to shell, there may be an unsupported width equal to the flat plate margin, as given by the formula in *Pt 5, Ch 10, 9.4 Flat plate margins 9.4.1*. The required tube plate thickness within such a tube nest is to be determined using the formula in *Pt 5, Ch 10, 9.1 Stayed flat surfaces 9.1.6*, where:

$$C = 0,154$$

d = four times the mean pitch, in mm, of the expanded tubes in the nest.

9.1.10 The thickness, t , of any tube plate in the tube area is to be not less than that required for the surrounding plate determined by *Pt 5, Ch 10, 9.1 Stayed flat surfaces 9.1.6* and in no case less than:

- (a) 12,5 mm where the diameter of the tube hole does not exceed 50 mm, or
- (b) 14 mm where the diameter of the tube hole is greater than 50 mm.

9.1.11 Alternative methods of support will be specially considered.

9.1.12 The spacing of tube holes is to be such that the minimum width, b , in mm of any ligament between tube holes is not less than:

for expanded tubes:

$$b = 0,125d + 12,5 \text{ mm}$$

for welded tubes:

$$b = 0,125d + 8 \text{ mm}$$

where d = diameter of the hole drilled in the plate, in mm.

9.1.13 Where a flat plate has a manhole or sight hole and the opening is strengthened by flanging, the total depth, H , of the flange, measured from the outer surface of the plate, is to be not less than:

$$H = \sqrt{tW}$$

where

t = thickness of plate, in mm

H = depth of flange, in mm

W = minor axis of manhole or sight hole, in mm.

9.1.14 Where the flat top plates of combustion chambers are supported by welded-on girders, the equation in *Pt 5, Ch 10, 9.1 Stayed flat surfaces 9.1.6* is to apply as follows:

(a) In the case of welded-on girders provided with waterways

$$C = 0,144$$

$$d = \sqrt{X^2 + Y^2}$$

where

X = width of waterway in the girder plus the thickness of the girder, in mm

Y = pitch of girders, in mm.

(b) In the case of continuously welded-on girders

$$C = 0,175$$

$$d = D$$

where

D = distance between inside faces of girders, in mm.

9.2 Combustion chamber tube plates under compression

9.2.1 The thickness of combustion chamber tube plates under compression due to the pressure on the top plate, based on a compressive stress not exceeding 96 N/mm² is to be determined by the following formula:

$$t = \frac{pWs}{1930(s-d)} \text{mm}$$

= where t and p are as defined in *Pt 5, Ch 10, 1.2 Definition of symbols*

d = internal diameter of the plain tubes, in mm

s = pitch of tubes, in mm, measured horizontally where tubes are chain pitched, or diagonally where the tubes are staggered pitched and the diagonal pitch is less than the horizontal pitch

W = internal width of the combustion chamber, in mm, measured from tube plate to back chamber plate.

9.3 Girders for combustion chamber top plates

9.3.1 The formula in *Pt 5, Ch 10, 9.3 Girders for combustion chamber top plates 9.3.2* is applicable to plate girders welded to the top combustion chamber plate by means of a full penetration weld.

9.3.2 The thickness of steel plate girders supporting the tops of combustion chambers is to be determined by the following formula:

$$t = \frac{0,32pl^2s}{d^2R_{20}} \text{mm}$$

= where t and p are as defined in *Pt 5, Ch 10, 1.2 Definition of symbols*

d = effective depth of girder, in mm

l = length of girder measured internally from tube plate to back chamber plate, in mm

s = pitch of the girders, in mm

R_{20} = specified minimum tensile strength of the girder plate, in N/mm².

9.4 Flat plate margins

9.4.1 The width of margin, b , of a flat plate which may be regarded as being supported by the shell, furnaces or flues to which the flat plate is attached is not to exceed that determined by the following formula:

$$b = C(t - 0,75)\sqrt{\frac{\sigma}{p}} \text{ mm}$$

= where p and σ are as defined in *Pt 5, Ch 10, 1.2 Definition of symbols*

t = thickness of the flat plate, in mm

b = width of margin, in mm

C = 3,12.

9.4.2 Where an unflanged flat plate is welded directly to the shell, furnaces or flues and it is not practicable to effect the full penetration weld from both sides of the flat plate, the constant C used in the formula in *Pt 5, Ch 10, 9.4 Flat plate margins 9.4.1* is to be:

C = 2,38.

9.4.3 In the case of plates which are flanged, the margin is to be measured from the commencement of curvature of flanging, or from a line 3,5 times the thickness of the plate measured from the outside of the plate, whichever is nearer to the flange.

9.4.4 Where the flat plate is not flanged for attachment to the shell, furnaces or flues, the margin is to be measured from inside of the shell or the outside of the furnaces or flues, whichever is applicable.

9.4.5 In no case is the diameter D , in mm, of the circle forming the boundary of the margin supported by the uptake of a vertical boiler to be greater than determined by the following formula:

$$D = \sqrt{\frac{345A}{p} + d^2}$$

= where p is as defined in *Pt 5, Ch 10, 1.2 Definition of symbols*

d = external diameter of uptake, in mm

d_i = internal diameter of uptake, in mm

A = cross-sectional area of the uptake tube material,

i.e. $\frac{\pi}{4}(d^2 - d_i^2) \text{ mm}^2$.

■ Section 10 **Flat plates and ends of vertical boilers**

10.1 Tube plates of vertical boilers

10.1.1 Where vertical boilers have a nest or nests of horizontal tubes, so that there is direct tension on the tube plates due to the vertical load on the boiler ends or to their acting as horizontal ties across the shell, the thickness of the tube plates in way of the outer rows of tubes is to be determined by the following formula:

$$t = \frac{pD}{5JR_{20}} + 0,75\text{mm}$$

= where t and p are as defined in *Pt 5, Ch 10, 1.2 Definition of symbols*

D = twice the radial distance of the centre of the outer row of tube holes from the axis of the shell, in mm

J = efficiency of ligaments between tube holes in the outer vertical rows (expressed as a fraction)

$$= \frac{s - d}{s}$$

R_{20} = specified minimum tensile strength of tube plate, in N/mm^2

where

d = diameter of tube holes, in mm

s = vertical pitch of tubes, in mm.

10.1.2 Each alternate tube in the outer vertical rows of tubes is to be a tube welded at both ends as shown in *Figure 10.9.4 Detail of weld for tube*. Further, the arrangement of tubes in the nests is to be such that the thickness of the tube plates meets the requirements of *Pt 5, Ch 10, 9.1 Stayed flat surfaces*.

10.1.3 Where the vertical height of the tube plates between the top and bottom shelves exceeds 0,65 times the internal diameter of the boiler, the staying of the tube plates, and the scantlings of the tube plates and shell plates to which the sides of the tube plates are connected, will require to be specially considered. It is recommended, however, that for this type of boiler the vertical height of the tube plates between the top and bottom shelves should not exceed 1,25 times the internal diameter of the boiler.

10.2 Horizontal shelves of tube plates forming part of the shell

10.2.1 For vertical boilers of the type referred to in *Pt 5, Ch 10, 10.1 Tube plates of vertical boilers*, in order to withstand vertical load due to pressure on the boiler ends, the horizontal shelves of the tube plates are to be supported by gussets in accordance with the following formula:

$$C = \frac{AD_i p}{t}$$

where

p = design pressure, in bar

t = thickness of the tube plate, in mm

A = maximum horizontal dimension of the shelf from the inside of the shell plate to the outside of the tube plate, in mm

D_i = inside diameter of the boiler, in mm.

10.2.2 For the combustion chamber tube plate the minimum number of gussets is to be:

1 gusset, where C exceeds 255 000

2 gussets, where C exceeds 350 000

3 gussets where C exceeds 420 000.

10.2.3 For the smokebox tube plate the minimum number of gussets is to be:

1 gusset where C exceeds 255 000

2 gussets where C exceeds 470 000.

10.2.4 The shell plates to which the sides of the tube plates are connected are to be not less than 1,6 mm thicker than is required by the formula applicable to shell plates with continuous circularity, and where gussets or other stays are not fitted to the shelves, the strength of the parts of the circumferential seams at the top and bottom of these plates from the outside of one tube plate to the outside of the other, is to be sufficient to withstand the whole load on the boiler end with a factor of safety of not less than 4,5 related to R_{20} (where R_{20} is the specified minimum tensile strength of the shell plates, in N/mm^2).

Steam Raising Plant and Associated Pressure Vessels **Part 5, Chapter 10**

10.3 Dished and flanged ends for vertical boilers

10.3.1 The minimum thickness, t , of dished and flanged ends for vertical boilers which are subject to pressure on the concave side and are supported by central uptakes is to be determined by the following formula:

$$t = \frac{pR_i}{13\sigma} + 0,75\text{mm}$$

where

t , p , R_i and σ are as defined in Pt 5, Ch 10, 1.2 Definition of symbols.

10.3.2 The inside radius of curvature, R_i , of the end plate is to be not greater than the external diameter of the cylinder to which it is attached.

10.3.3 The inside knuckle radius, r_i , see Figure 10.4.2 Typical dished ends(a), of the arc joining the cylindrical flange to the spherical surface of the end is to be not less than four times the thickness of the end plate, and in no case less than 65 mm.

10.3.4 The inside radius of curvature of flange to uptake is to be not less than twice the thickness of the end plate, and in no case less than 25 mm.

10.3.5 If the dished end has a manhole, the opening is to be strengthened by flanging. The total depth, H , of the flange, measured from the outer surface of the plate on the minor axis, is to be not less than

$$H = \sqrt{tW}$$

where

t = thickness of the flange, in mm

H = depth of flange, in mm

W = minor axis of the manhole, in mm.

10.4 Flat crowns of vertical boilers

10.4.1 The minimum thickness of flat crown plates of vertical boilers is to be determined as in Pt 5, Ch 10, 9.1 Stayed flat surfaces; d and C are defined as follows:

- Where the crown is supported by an uptake only,

d = diameter, in mm, of the largest circle which can be drawn between the connections to the shell or firebox and uptake, see Pt 5, Ch 10, 9.1 Stayed flat surfaces 9.1.1 to Pt 5, Ch 10, 9.1 Stayed flat surfaces 9.1.5

C = 0,161

- Where bar stays are fitted in accordance with Pt 5, Ch 10, 9.1 Stayed flat surfaces 9.1.6 and Pt 5, Ch 10, 9.1 Stayed flat surfaces 9.1.7:

d = diameter of the largest circle which can be drawn through at least three points of support, in mm

C = the mean of the values for the respective points of support through which the circle passes.

■ Section 11 Furnaces subject to external pressure

11.1 Maximum thickness

11.1.1 Furnaces, plain or corrugated, are not to exceed 22,5 mm in thickness.

11.2 Corrugated furnaces

11.2.1 The minimum thickness, t , of corrugated furnaces is to be determined by the following formula:

$$t = \frac{pD_o}{C} + 0,75 \text{ mm}$$

= where p is as defined in *Pt 5, Ch 10, 1.2 Definition of symbols*

t = thickness of the furnace plate measured at the bottom of the corrugations, in mm

C = 1060 for Fox, Morison and Deighton corrugations

= 1130 for Suspension Bulb corrugations

D_o = external diameter of the furnace measured at the bottom of the corrugations, in mm.

11.3 Plain furnaces, flue sections and combustion chamber bottoms

11.3.1 The minimum thickness, t , between points of substantial support, of plain furnaces or furnaces strengthened by stiffening rings, of flue sections and of the cylindrical bottoms of combustion chambers is to be determined by the following formulae the greater of the two thicknesses obtained being taken:

$$t = \sqrt{\frac{pD_o(L + 610)}{102\,400}} + 0,75 \text{ mm}$$

$$t = \frac{CpD_o}{1100} + \frac{L}{320} + 0,75 \text{ mm}$$

= where t and p are as defined in *Pt 5, Ch 10, 1.2 Definition of symbols*

C = $\frac{2x}{x + \sigma}$ or 0,85 whichever is the greater

D_o = external diameter of the furnace, flue or combustion chamber, in mm

L = length of section between the centres of points of substantial support, in mm

= x and σ are as defined in *Pt 5, Ch 10, 11.7 Dished and flanged ends for unsupported vertical boiler furnaces 11.7.1.*

11.3.2 Where stiffeners are used for strengthening plain cylindrical furnaces, or combustion chambers, the second moment of area, I , of the stiffener is to be determined by the following formula:

$$I = \frac{pD_o^3 L}{13,3 \times 10^6} \text{ mm}^4$$

= where p is as defined in *Pt 5, Ch 10, 1.2 Definition of symbols*

D_o = external diameter of the furnace flue or combustion chamber, in mm

L = length of section between the centres of points of substantial support, in mm

For proportion of stiffening rings, see *Figure 10.11.1 Furnace, flue and combustion chamber stiffeners.*

11.4 Plain furnaces of vertical boilers

11.4.1 The thickness of plain furnaces not exceeding 2000 mm in external diameter is to be determined by the formulae given in *Pt 5, Ch 10, 11.3 Plain furnaces, flue sections and combustion chamber bottoms 11.3.1*, the greater of the two thicknesses being taken:

where

D_o = external diameter of the furnace, in mm. Where the furnace is tapered, the diameter to be taken for calculation purposes is to be the mean of that at the top and that at the bottom where it meets the substantial support from flange, ring or row of stays

L = effective length, in mm, of the furnace between the points of substantial support as indicated in *Figure 10.11.2 Effective length, L, for use in 11.4*.

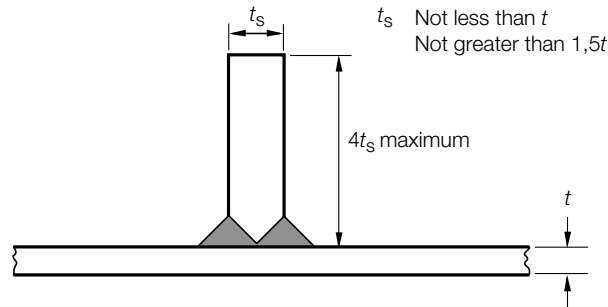

Figure 10.11.1 Furnace, flue and combustion chamber stiffeners

11.4.2 For furnaces under 760 mm in external diameter, the thickness is to be not less than 8 mm, and for furnaces 760 mm in external diameter and over, the thickness is to be not less than 9,5 mm.

11.4.3 A circumferential row of stays connecting the furnace to the shell will be considered to provide substantial support to the furnace, provided that:

- The diameter of the stay is not less 22,5 mm or twice the thickness of the furnace, whichever is the greater.
- The pitch of the stays at the furnace does not exceed 14 times the thickness of the furnace.

11.5 Hemispherical furnaces

11.5.1 The minimum thickness, t , of unsupported hemispherical furnaces subject to pressure on the convex surface is to be determined by the following formula:

$$t = \frac{CpR_o}{608} + 0,75 \text{ mm}$$

= where t and p are as defined in Pt 5, Ch 10, 1.2 Definition of symbols

= x and σ are as defined in Pt 5, Ch 10, 11.7 Dished and flanged ends for unsupported vertical boiler furnaces 11.7.1

$$C = \frac{2x}{x + \sigma} \text{ or } 0,85 \text{ whichever is greater}$$

R_o = outer radius of curvature of the furnace, in mm.

11.5.2 In no case is the maximum thickness to exceed 22,5 mm or the ratio $\frac{R_o}{t - 0,75}$ to exceed 100.

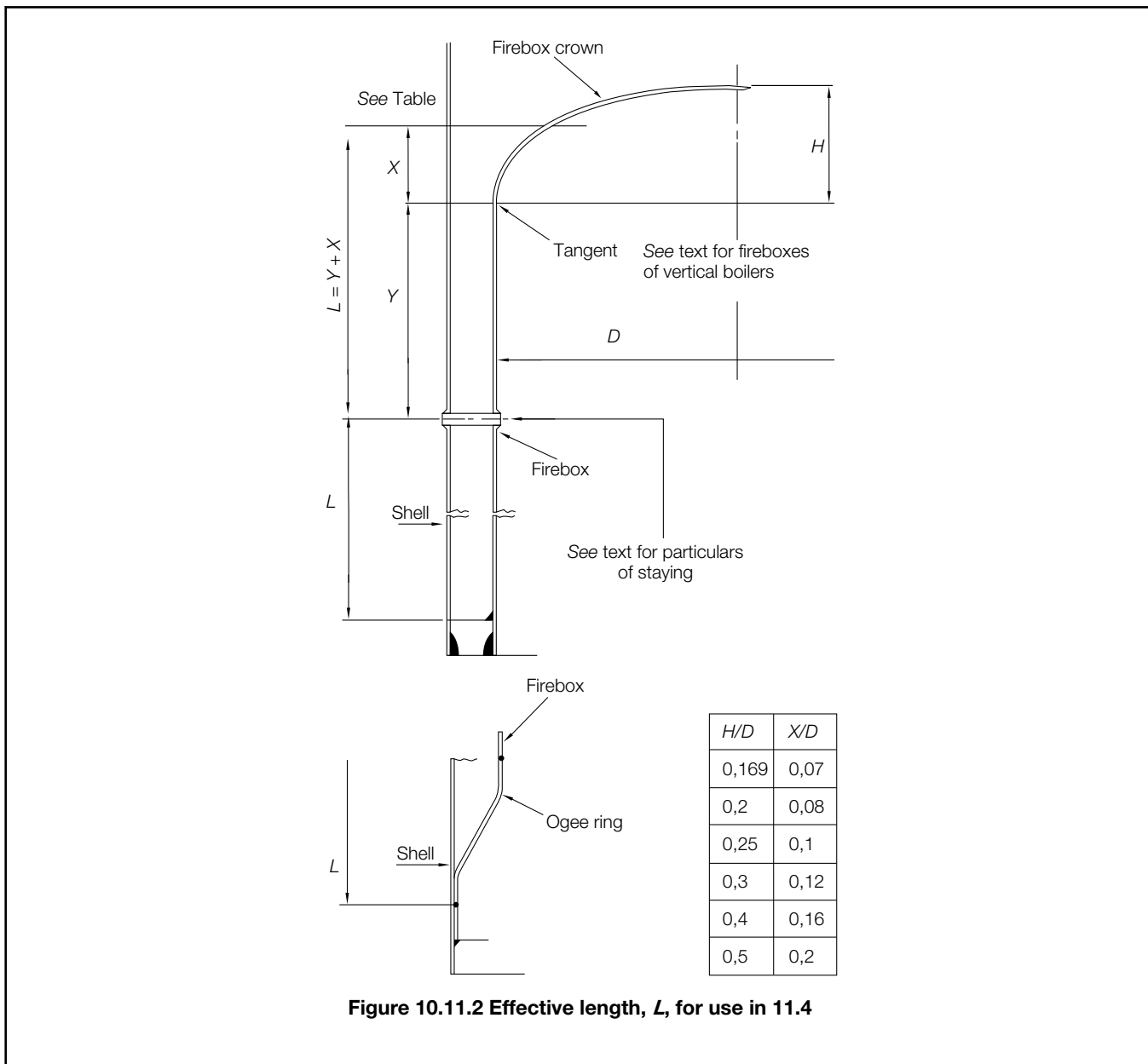

Figure 10.11.2 Effective length, *L*, for use in 11.4

11.6 Dished and flanged ends for supported vertical boiler furnaces

11.6.1 The minimum thickness, *t*, of dished and flanged ends for vertical boiler furnaces that are subject to pressure on the convex side and are supported by central uptakes, is to be determined by the following formula:

$$t = \frac{pR_o}{10\sigma} + 0,75 \text{ mm}$$

where *t*, *p*, *R_o* and *σ* are as defined in Pt 5, Ch 10, 1.2 Definition of symbols.

11.6.2 The inside radius of dishing and flanging are to be as required by Pt 5, Ch 10, 10.3 Dished and flanged ends for vertical boilers.

11.7 Dished and flanged ends for unsupported vertical boiler furnaces

11.7.1 The minimum thickness, *t*, of dished and flanged ends for vertical boiler furnaces that are subject to pressure on the convex side and are without support from stays of any kind, is to be determined by the following formula, but is in no case to be less than the thickness of the firebox:

$$t = \frac{CpR_o}{660} + 0,75 \text{ mm}$$

where t and p are as defined in Pt 5, Ch 10, 1.2 Definition of symbols.

x = specified minimum lower yield stress or 0,2 per cent proof stress in N/mm² at a temperature 90°C above the saturated steam temperature corresponding to the design pressure for carbon and carbon manganese steel with a specified minimum tensile strength of 400 N/mm²

$$C = \frac{2x}{x + \sigma} \text{ or } 0,85 \text{ whichever is the greater}$$

R_o = outside radius of the crown plate, in mm

$$= \left(\text{in no case is } \frac{R_o}{t} \text{ to exceed } 88 \right)$$

σ = specified minimum lower yield stress or 0,2 per cent proof stress in N/mm² at a temperature 90°C above the saturated steam temperature corresponding to the design pressure for the steel actually used

11.7.2 The inside radius of curvature, R_i , of the end plate is to be not greater than the external diameter of the cylinder to which it is attached.

11.7.3 The inside knuckle radius, r_i , see Figure 10.4.2 Typical dished ends(a), of the arc joining the cylindrical flange to the spherical surface of the end is to be not less than four times the thickness of the end plate and in no case less than 65 mm.

11.8 Ogee rings

11.8.1 The minimum thickness, t , of the ogee ring which connects the bottom of the furnace to the shell of a vertical boiler and sustains the whole vertical load on the furnace is to be determined by the following formula:

$$t = \sqrt{\frac{pD_i(D_i - D_o)}{9900}} + 0,75 \text{ mm}$$

= where t and p are as defined in Pt 5, Ch 10, 1.2 Definition of symbols

D_i = inside diameter of boiler shell, in mm

D_o = outside diameter of the lower part of the furnace where it joins the ogee ring, in mm.

11.8.2 Proposals to use a flat plate annular ring which connects the bottom of the furnace to the shell of a vertical boiler and sustains any unbalanced vertical load on the furnace will be the subject of special consideration.

11.9 Uptakes of vertical boilers

11.9.1 The minimum thickness, t , of internal uptakes of vertical boilers is to be determined by the following formulae, the greater of the two thicknesses obtained being taken:

$$t = \sqrt{\frac{pD_o(L + 610)}{102\,400}} + 4 \text{ mm}$$

$$t = \frac{pD_o}{1100} + \frac{L}{320} + 4 \text{ mm}$$

= where t and p are as defined in Pt 5, Ch 10, 1.2 Definition of symbols

D_o = external diameter of uptake, in mm

L = length of uptake between the centres of points of substantial support, in mm.

■ *Section 12*
Boiler tubes subject to external pressure

12.1 Tubes

12.1.1 The thickness of tubes is to be in accordance with *Table 10.12.1 Thickness of plain tubes under external pressure* for the appropriate outside diameter and design pressure.

Table 10.12.1 Thickness of plain tubes under external pressure

Design pressure, in bar											Thickness, in mm
Outside diameter, in mm											
38	44,5	51	57	63,5	70	76	82,5	89	95	102	
—	—	—	—	—	—	—	—	—	26,9	25,2	5,89
—	—	—	—	—	—	—	26,2	24,1	22,8	21,4	5,38
—	—	—	—	—	—	24,1	22,1	20,7	19,3	17,9	4,88
—	—	—	27,6	24,8	22,8	20,7	19,3	17,9	16,6	15,9	4,47
—	29,3	25,5	22,8	20,7	18,9	17,3	15,9	14,8	13,7	12,7	4,06
26,6	22,8	20,7	17,9	15,9	14,8	13,1	12,4	11,4	10,3	9,6	3,66
20,3	16,9	14,8	13,1	12,1	11,0	9,6	8,9	8,2	7,6	6,9	3,25
14,8	12,4	10,7	9,6	8,6	7,6	—	—	—	—	—	2,95

12.1.2 Tubes may be welded at both ends, welded at the inlet end and expanded at the outlet end, or expanded at both ends. In addition to expanding, tubes may be bell mouthed or beaded at the inlet end. Where tubes are welded, the weld detail is to be as shown in *Figure 10.9.4 Detail of weld for tube* and the tubes are to be expanded into the tube plates in addition to welding, except as permitted by *Pt 5, Ch 10, 12.1 Tubes 12.1.3*.

12.1.3 For tubes of thickness greater than 6,0 mm, expanding in addition to welding is not required if a recessed weld of depth not less than the tube thickness is provided.

■ *Section 13*
Tubes welded at both ends and bar stays for cylindrical boilers

13.1 Loads on tubes welded at both ends and bar stays

13.1.1 Each tube or bar stay is to be designed to carry its due proportion of the load on the plates which it supports.

13.1.2 For a tube or bar stay, the net area to be supported is to be the area, in mm², enclosed by the lines bisecting at right angles the lines joining the stay and the adjacent points of support, less the area of any tubes or stays enclosed. In the case of a tube or bar stay in the boundary rows, the support afforded by the flat plate margin, where applicable, should be taken into account. Where flat margins overlap stays are not required.

13.1.3 The thickness of tubes welded at both ends to tube plates is to be such that the longitudinal stress due to the flat plate loading does not exceed 70 N/mm².

13.1.4 Tubes may be welded into the boiler after post-weld heat treatment has been carried out.

13.1.5 The permissible longitudinal stress in combustion chamber bar stays or similar stays where an end is heated by flame, is not to exceed 70 N/mm², and the diameter of this type of bar stay is not to be less than 19 mm.

13.1.6 The permissible longitudinal stress in longitudinal bar stays not subject to heating, is not to exceed 20 per cent of the minimum specified tensile strength, in N/mm², and the diameter of this type of bar stay is not to be less than 25 mm.

■ Section 14 Construction

14.1 Access arrangements

14.1.1 In watertube boilers, manholes are to be provided in all drums of sufficient size to allow access for internal examination and cleaning, and for fitting and expanding the tubes. In the case of headers for water walls, superheaters or economisers, and of drums which are too small to permit entry, sight holes or mudholes sufficiently large and numerous for these purposes are to be provided.

14.1.2 Cylindrical boilers are to be provided, where possible with means for ingress to permit examination and cleaning of the inner surfaces of plates and tubes exposed to flame. Where the boilers are too small to permit this, there are to be sight holes and mudholes sufficiently large and numerous to allow the inside to be satisfactorily cleaned.

14.1.3 Where the cross tubes of vertical boilers are large, there is to be a sight hole in the shell opposite to one end of each tube sufficiently large to allow the tube to be examined and cleaned. These sight holes are to be in positions accessible for that purpose.

14.1.4 Manholes in cylindrical shells should preferably have their shorter axes arranged longitudinally.

14.1.5 Doors for manholes, mudholes and sight holes are to be formed from steel plate or other approved construction, and all jointing surfaces are to be machined.

14.1.6 Doors of the internal type are to be provided with spigots which have a clearance of not more than 1,5 mm all round, i.e. the axes of the opening are not to exceed those of the door by more than 3 mm. The width of the manhole gasket seat is to be not less than 16 mm.

14.1.7 Doors of the internal type for openings not larger than 230 mm x 180 mm need be fitted with one stud only, which may be forged integral with the door. Doors for openings larger than 230 mm x 180 mm are to be fitted with two studs or bolts. The strength of the attachment to the door is to be not less than the strength of the stud or bolt.

14.1.8 The crossbars or dogs for doors are to be of steel.

14.1.9 For smaller circular openings in headers and similar fittings, an approved type of plug may be used.

14.1.10 Circular flat cover plates may be fitted to raised circular manhole frames not exceeding 400 mm diameter, and for an approved design pressure not exceeding 18 bar.

14.1.11 External circular flat cover plates are to be in accordance with a recognised National Standard.

14.2 Torispherical and semi-ellipsoidal ends

14.2.1 For typical acceptable types of attachment for dished ends to cylindrical shells, see *Figure 10.14.1 Typical attachments of dished ends to cylindrical shells*.

14.2.2 Where the difference in thickness is the same throughout the circumference, the thicker plate is to be reduced in thickness by machining to a taper for a distance not less than four times the offset, so that the two plates are of equal thickness at the position of the circumferential weld. A parallel portion may be provided between the end of the taper and weld edge preparation; alternatively, if so desired, the width of the weld may be included as part of the smooth taper of the thicker plate.

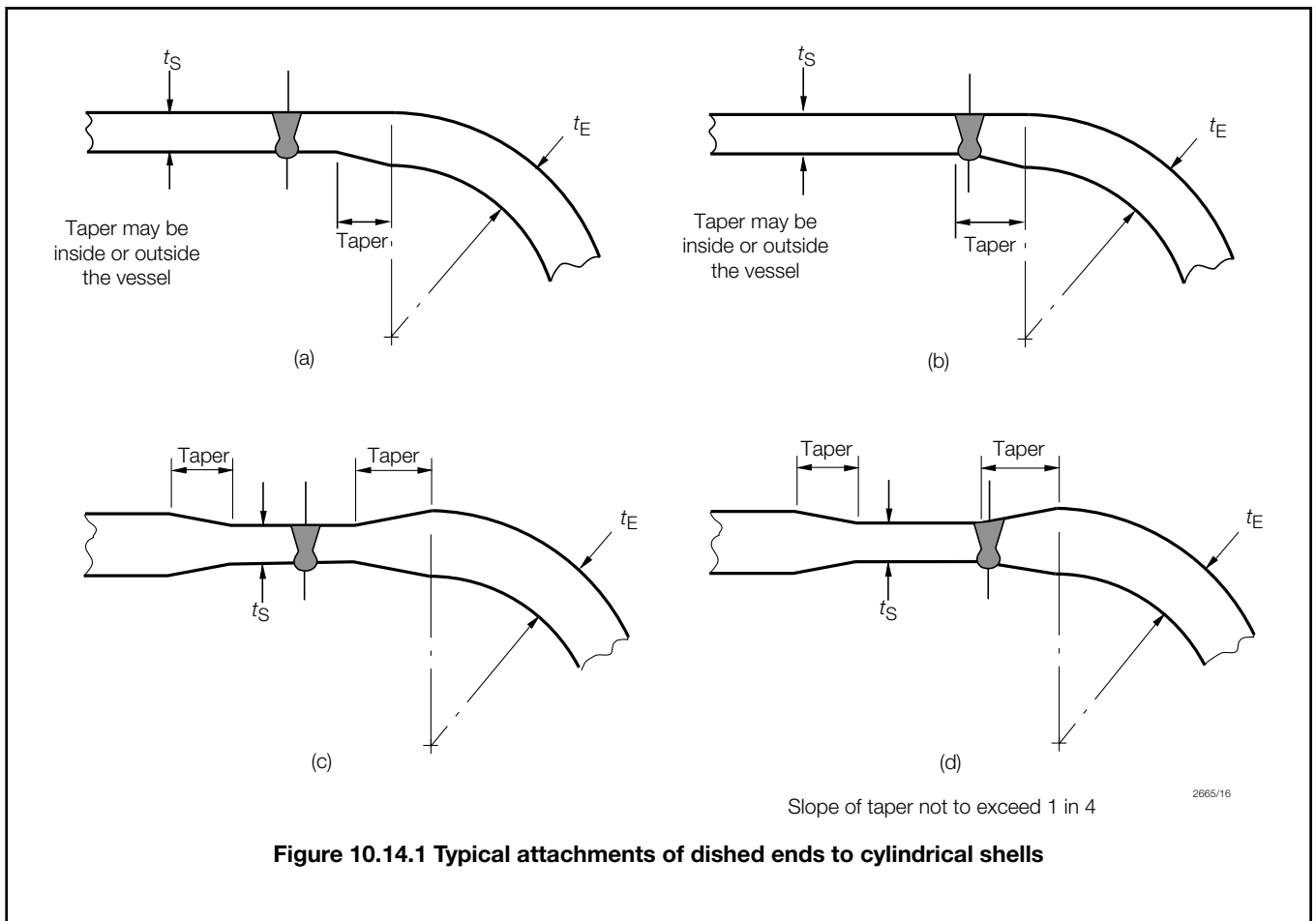

Figure 10.14.1 Typical attachments of dished ends to cylindrical shells

14.2.3 The thickness of the plates at the position of the circumferential weld is to be not less than that of an unpierced cylindrical shell of seamless or welded construction, whichever is applicable, of the same diameter and material, see Pt 5, Ch 10, 4.1 Minimum thickness.

14.3 Hemispherical ends

14.3.1 Where hemispherical ends are butt welded to cylindrical shells, the thickness of the shell is to be reduced by taper to that of the end, and the centre of the hemisphere is to be so located that the entire tapered portion of the shell and the butt weld are within the hemisphere, see Figure 10.14.2 Attachment of hemispherical end to cylindrical shell.

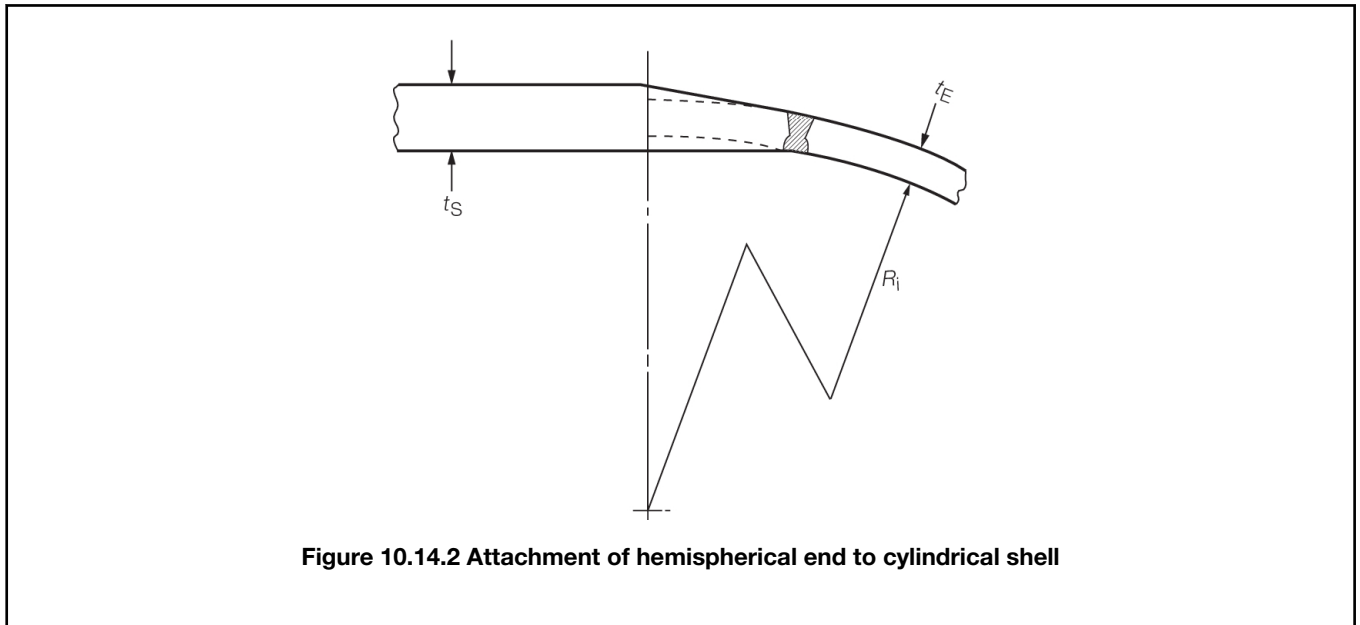

Figure 10.14.2 Attachment of hemispherical end to cylindrical shell

14.3.2 If the hemispherical end is provided with a parallel portion, the thickness of this portion is to be not less than that of a seamless or welded shell, whichever is applicable, of the same diameter and material.

14.4 Welded-on flanges, butt welded joints and fabricated branch pieces

14.4.1 Flanges may be cut from plates or may be forged or cast. Hubbed flanges are not to be machined from plate. Flanges are to be attached to branches by welding. Alternative methods of flange attachment will be subject to special consideration.

14.4.2 The types of welded-on flanges are to be suitable for the pressure, temperature and service for which the branches are intended.

14.4.3 Flange attachments and pressure-temperature ratings in accordance with materials and design of recognised Standards will be accepted.

14.4.4 Typical examples of welded-on flange connections are shown in *Figure 10.14.3 Typical examples of welded flange connections* (a) to (f), and limiting design conditions for the flange types are shown in *Table 10.14.1 Limiting design conditions for flanges*. In *Figure 10.14.3 Typical examples of welded flange connections* t is the minimum Rule thickness of the standpipe or branch.

14.4.5 Welded-on flanges are not to be a tight fit on the branch. The maximum clearance between the bore of the flange and the outside diameter of the branch is to be 3 mm at any point, and the sum of the clearances diametrically opposite is not to exceed 5 mm.

14.4.6 Where butt welds are employed in the attachment of flange type (a), or in the construction of standpipes or branch pieces, the adjacent pieces are to be matched at the bores. This may be effected by drifting, roller expanding or machining, provided the pipe wall is not reduced below the designed thickness. If the parts to be joined differ in wall thickness, the thicker wall is to be gradually tapered to that of the thinner at the butt joint.

14.4.7 Welding may be carried out by means of the shielded metal arc, inert gas metal arc, oxy-acetylene or other approved process, but in general, oxy-acetylene welding is suitable only for flange type (a) and is not to be applied to branches exceeding 100 mm diameter or 9,5 mm thick. The welding is to be carried out in accordance with the appropriate paragraphs of *Pt 5, Ch 17 Requirements for Fusion Welding of Pressure Vessels and Piping*.

14.4.8 Threaded sleeve joints complying with *Pt 5, Ch 12, 2.8 Socket weld joints 2.8.1* may be used on the steam and water piping of small oil fired package boilers of the once through coil type, used for auxiliary or domestic purposes, where the feed pump capacity limits the output.

14.4.9 Socket weld joints are not to be used where fatigue, severe erosion, crevice corrosion or stress corrosion is expected to occur, for example, blow down, drain, scum and chemical dosing connections.

Steam Raising Plant and Associated Pressure Vessels **Part 5, Chapter 10**

Section 14

14.5 Welded attachments to pressure vessels

14.5.1 Unless the actual thickness of the shell or end is at least twice that required by calculation for a seamless shell or end, whichever is applicable, doubling plates with well rounded corners are to be fitted in way of attachments such as lifting lugs, supporting brackets and feet, to minimise load concentrations on pressure shells and ends. Compensating plates, pads, brackets and supporting feet are to be bedded closely to the surface before being welded, and are to be provided with a 'tell-tale' hole not greater than 9,5 mm in diameter, open to the atmosphere to provide for the release of entrapped air during heat treatment of the vessel, or as a means of indicating any leakage during hydraulic testing and in service, see Pt 5, Ch 17 Requirements for Fusion Welding of Pressure Vessels and Piping.

14.5.2 For acceptable methods of attaching standpipes, branches, compensating plates and pads, see Figure 10.14.4 Typical acceptable methods of attaching branches and pads. Alternative methods of attachment may be accepted provided details are submitted for consideration.

14.5.3 Where fillet welds are used to attach standpipes or set-in pads, there are to be equal sized welds both inside and outside the vessel, see Figure 10.14.4 Typical acceptable methods of attaching branches and pads(a) and (l). The leg length of each of the fillet welds is to be not less than 1,4 times the actual thickness of the thinner of the parts being joined.

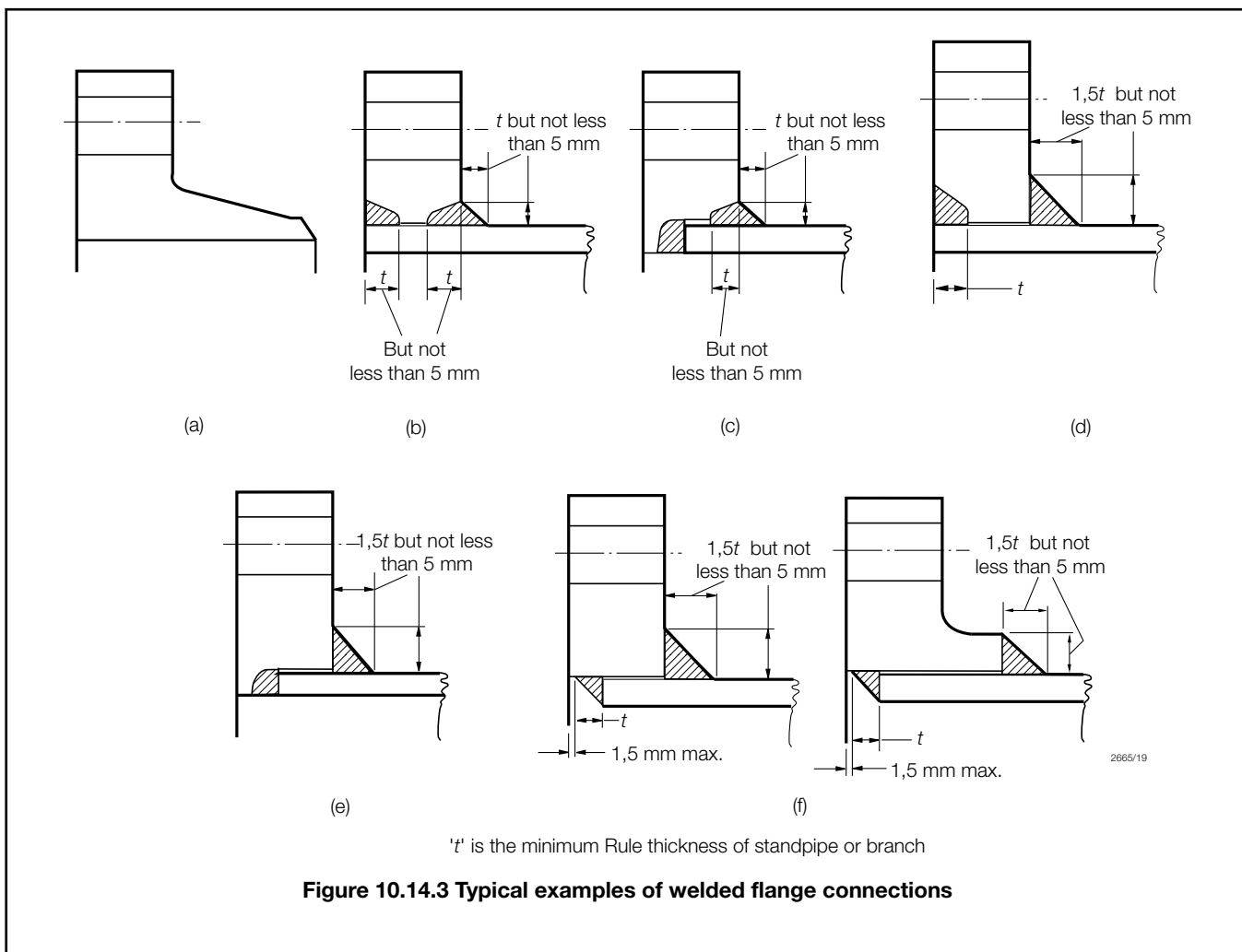

Table 10.14.1 Limiting design conditions for flanges

Flange type	Maximum pressure	Maximum temperature	Maximum pipe o.d.	Minimum pipe bore
		°C	mm	mm

Steam Raising Plant and Associated Pressure Vessels **Part 5, Chapter 10**

(a)	Pressure-temperature ratings to be in accordance with a recognised standard	No restriction	No restriction	No restriction
(b)	Pressure-temperature ratings to be in accordance with a recognised standard	No restriction	168,3 for alloy steels*	No restriction
(c)	Pressure-temperature ratings to be in accordance with a recognised standard	No restriction	168,3 for alloy steels*	75
(d)	Pressure-temperature ratings to be in accordance with a recognised standard	425	No restriction	No restriction
(e)	Pressure-temperature ratings to be in accordance with a recognised standard	425	No restriction	75
(f)	Pressure-temperature ratings to be in accordance with a recognised standard	425	No restriction	No restriction

* No restriction for carbon steels

14.6 Fitting of tubes in water tube boilers

14.6.1 The tube holes in drums or headers are to be formed in such a way that the tubes can be effectively tightened in them. Where the tube ends are not normal to the tube plates, there is to be a neck or belt of parallel seating of at least 13 mm in depth, measured in a plane through the axis of the tube at the holes. Where the tubes are practically normal to their plates, this parallel seating is to be not less than 9,5 mm in depth.

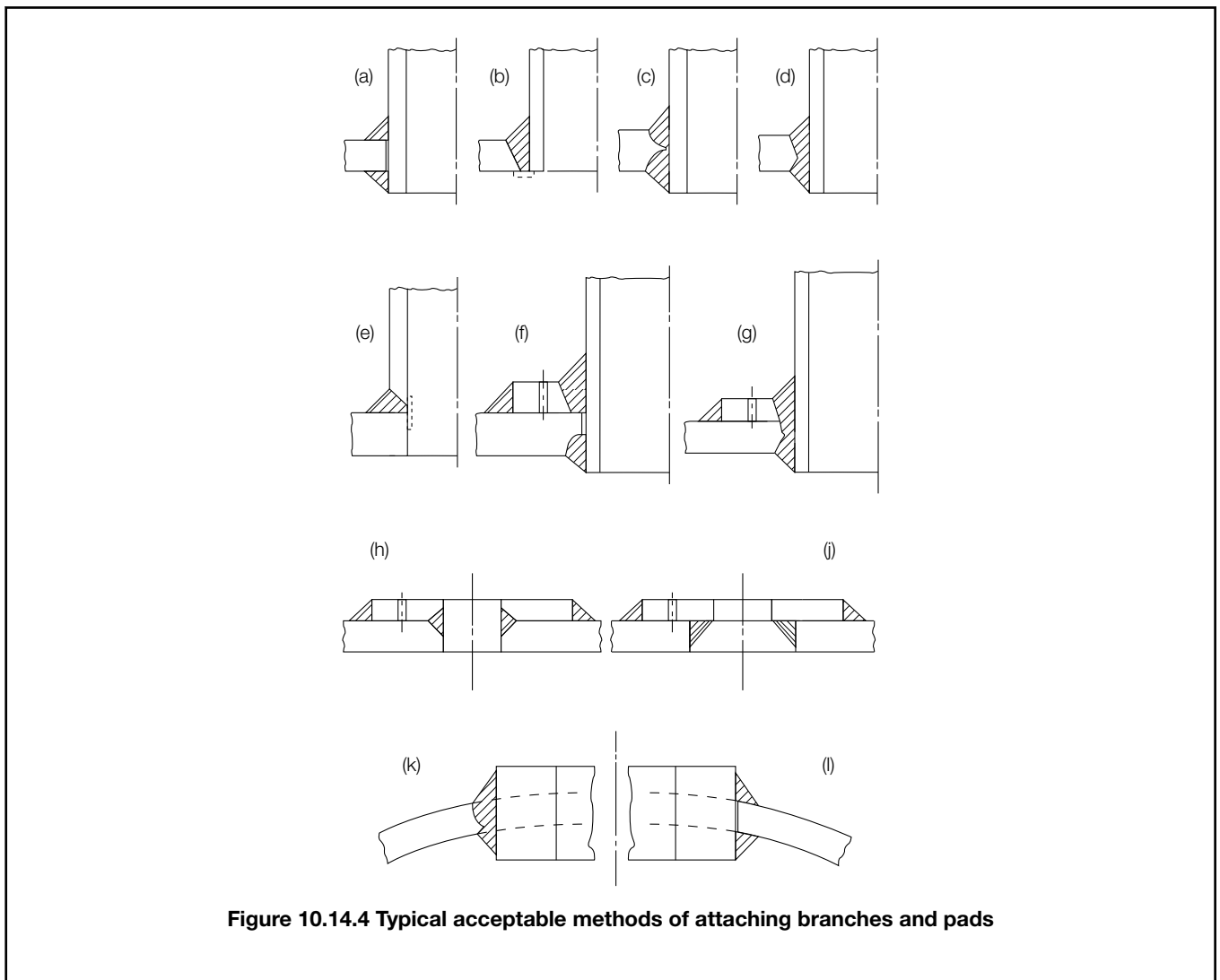

14.6.2 Tubes are to be carefully fitted in the tube holes and secured by means of welding, expanding and belling or by other approved methods. Tubes are to project through the neck or belt of parallel seating by at least 6 mm and where they are secured from drawing out by means of bellmouthing only, the included angle of belling is to be not less than 30°.

■ *Section 15*
Mountings and fittings for cylindrical and vertical boilers, steam generators, pressurised thermal liquid and pressurised hot water heaters

15.1 General

15.1.1 Valves over 38 mm diameter are to be fitted with outside screws, and the covers are to be secured by bolts or studs. All valves are to be arranged to shut with a right-hand (clockwise) motion of the wheels.

15.1.2 All valves and cocks connected to the boiler are to be such that it is seen without difficulty whether they are open or shut. Where boiler mountings are secured by studs, the studs are to have a full thread holding in the plate for a length of at least one diameter.

15.1.3 Where a superheater is fitted which can be shut off from the boiler, it is to be provided with a separate safety valve fitted with easing gear. The valve as regards construction is to comply with the regulations for ordinary safety valves, but the easing gear

Steam Raising Plant and Associated Pressure Vessels **Part 5, Chapter 10**

may be fitted to be workable from the stokehold only. The superheater is also to be fitted with a drain valve or cock to free it from water when necessary.

15.1.4 Safety valve chests and other boiler and superheater mountings subjected to pressures exceeding 13,0 bar or to steam temperatures exceeding 220°C, and boiler blow-down fittings, are to be made of steel or other approved material.

15.2 Safety valves

15.2.1 Boilers and steam generators are to be fitted with not less than two safety valves, each having a minimum internal diameter of 25 mm, but those having a total heating surface of less than 50 m² may have one valve not less than 50 mm diameter. Small oil fired package boilers of the once through coil type used for auxiliary or domestic purposes, where the feed pump capacity limits the output, may have one safety valve not less than 19 mm internal diameter, or two safety valves with internal diameters not less than 16 mm, provided the capacity is in accordance with *Pt 5, Ch 10, 15.2 Safety valves 15.2.13*.

15.2.2 The valves, spindles, springs and compression screws are to be so encased and locked or sealed that the safety valves and pilot valves, after setting to the working pressure, cannot be tampered with or overloaded in service.

15.2.3 Valves are to be so designed that in the event of fracture of springs they cannot lift out of their seats.

15.2.4 Easing gear is to be provided for lifting the safety valves and is to be operable by mechanical means at a safe position from the boiler or engine room platforms.

15.2.5 Safety valves are to be made with working parts having adequate clearances to ensure complete freedom of movement.

15.2.6 Valve seats are to be effectively secured in position. Any adjusting devices which control discharge capacity are to be positively secured so that the adjustment will not be affected when the safety valves are dismantled at surveys.

15.2.7 All the safety valves of each boiler and steam generator may be fitted in one chest, which is to be separate from any other valve chest and is to be connected directly to the shell by a strong and stiff neck, the passage through which is to be of cross-sectional area not less than the aggregate area of the safety valves in the chest in the case of full lift valves, and one-half of that area in the case of other valves. For the meaning of aggregate area, see *Pt 5, Ch 10, 15.2 Safety valves 15.2.13*.

15.2.8 For each safety valve, an individual unrestricted drain is to be provided. The drain pipe is to be fitted to the lowest part of the discharge side of the safety valve; it is to be below the level of the valve seat and is to be independently led with a continuous fall to a place where the high temperature steam and/or condensate can discharge, visibly clear of the boilers and where it cannot cause injury. No valves or cocks are to be fitted to these drain pipes. The bore of the drain pipes is not to be less than 19 mm. Where a drain pipe of 19 mm is impracticable, smaller drain pipes may be considered.

15.2.9 Safety valves for shell type exhaust gas steaming economisers are to incorporate fail safe features which will ensure operation of the valve even with solid matter deposits on the valve and guide, or features that will prevent the accumulation of solid matter in way of the valve and in the clearance between the valve spindle and guide. Alternatively, if the fitted valves do not incorporate the features described then a bursting disc discharging to a suitable waste steam pipe is to be fitted in addition to the valves. These bursting discs are to function at a pressure not exceeding 1,25 times the economiser approved design pressure and are to have sufficient capacity to prevent damage to the economiser when operating at its design heat input level.

15.2.10 To avoid the accumulation of solid matter deposits on the outlet side of the safety valves and bursting discs required by *Pt 5, Ch 10, 15.2 Safety valves 15.2.9*, the discharge pipes and safety valve/bursting disc housings are to be fitted with drainage arrangements from the lowest part, directed with continuous fall to a position clear of the economiser where it will not pose a threat to either personnel or machinery. No valves or cocks are to be fitted in the drainage arrangements. The drainage arrangements required by *Pt 5, Ch 10, 15.2 Safety valves 15.2.8* may be accepted as meeting these requirements where the arrangements comply with this paragraph.

15.2.11 Full particulars of the proposed arrangements are to be submitted for consideration.

15.2.12 Where the receiver is fitted with safety valves to relieve the steam output of the economiser and the economiser cannot be isolated from the receiver the requirements of *Pt 5, Ch 10, 15.2 Safety valves 15.2.9* may be waived.

15.2.13 The designed discharge capacities of the safety valves on each boiler and steam generator are to be found from the following formulae:

Saturated steam safety valves:

$$E = \frac{AC(p + 1,03)}{98,1}$$

Superheated steam safety valves:

$$E = \frac{AC(p + 1,03)}{98,1} \sqrt{\frac{V_S}{V_H}}$$

where

p = set pressure, in bar gauge

A = for ordinary, high lift or improved high lift safety valves, the aggregate area, in mm², of the orifices through the seatings of the valves, neglecting the area of guides and other obstructions

= for full lift safety valves, the net aggregate area, in mm², through the seats after deducting the area of the guides or other obstructions when the valves are fully lifted

C = 4,8 for valves of ordinary type having a minimum lift of $\frac{D}{24}$

= 7,2 for valves of high lift type, having a minimum lift of $\frac{D}{16}$

= 9,6 for valves of improved high lift type having a minimum lift of $\frac{D}{12}$

= 19,2 for valves of full lift type having a minimum lift of $\frac{D}{4}$

D = bore of valve seat, in mm

E = the maker's specified peak load evaporation, in kg/hour (including all evaporation from water walls, integral, or steaming economisers and other heating surfaces in direct communication with the boiler)

V_H = specific volume of superheated steam (m³/kg)

V_S = specific volume of saturated steam (m³/kg).

15.2.14 When the discharge capacity of a safety valve of approved design has been established by type tests, carried out in the presence of the Surveyors or by an independent authority recognised by LR, on valves representative of the range of sizes and pressures intended for marine application, consideration will be given to the use of a constant higher than $C = 19,2$, based on 90 per cent of the measured capacity up to a maximum of $C = 45$ for full lift safety valves.

15.2.15 Pressurised thermal liquid and pressurised hot water heaters are to be provided with a safety relief device. The safety valve is to be designed and constructed in accordance with a relevant National or International Standard acceptable to LR.

15.3 Waste steam pipes

15.3.1 For ordinary, high lift and improved high lift type valves, the cross-sectional area of the waste steam pipe and passages leading to it is to be at least 10 per cent greater than the aggregate area of the safety valves as used in the formulae in *Pt 5, Ch 10, 15.2 Safety valves 15.2.13*. For full lift and other approved valves of high discharge capacity, the cross-sectional area of the waste steam pipe and passages is to be not less than 0,1C times the aggregate valve area.

15.3.2 The cross-sectional area of the main waste steam pipe is to be not less than the combined cross-sectional areas of the branch waste steam pipes leading thereto from the boiler safety valves.

15.3.3 Waste steam pipes are to be led to the atmosphere and are to be adequately supported and provided with suitable expansion joints, bends or other means to relieve the safety valve chests of undue loading.

15.3.4 The scantlings of waste steam pipes and silencers are to be suitable for the maximum pressure to which the pipes may be subjected in service, and in any case not less than 10 bar.

15.3.5 Silencers fitted to waste steam pipes are to be so designed that the clear area through the baffle plates is not less than that required for the pipes.

15.3.6 The safety valves of each exhaust gas heated economiser and exhaust gas heated boiler which may be used as an economiser are to be provided with entirely separate waste steam pipes.

15.3.7 External drains and exhaust steam vents to atmosphere are not to be led to waste steam pipes.

15.3.8 It is recommended that a scale trap and means for cleaning be provided at the base of each waste steam pipe.

Steam Raising Plant and Associated Pressure Vessels

Part 5, Chapter 10

Section 15

15.4 Adjustment and accumulation tests

15.4.1 All safety valves are to be set under steam to a pressure not greater than the approved pressure of the boiler. As a working tolerance the setting is acceptable provided the valves lift at not more than 103 per cent of the approved design pressure. During a test of 15 minutes with the stop valves closed and under full firing conditions the accumulation of pressure is not to exceed 10 per cent of the design pressure. During this test no more feed water is to be supplied than is necessary to maintain a safe working water level.

15.5 Stop valves

15.5.1 One main stop valve is to be fitted to each boiler and secured directly to the shell. There are to be as few auxiliary stop valves as possible so as to avoid piercing the boiler shell more than is absolutely necessary.

15.5.2 Where two or more boilers are connected together:

- Stop valves of self-closing or non-return type are to be fitted.
- Essential services are to be capable of being supplied from at least two boilers.

15.6 Water level indicators

15.6.1 Every boiler designed to contain water at a specified level is to be fitted with at least two means for indicating its water level, at least one of which is to be a direct reading gauge glass. The other means is to be either an additional gauge glass or an approved equivalent device. The required water level indicators are to be independent of each other.

15.6.2 Where a pair of gauge glasses are set at different levels to provide an extended range of water level indication they will only be considered as one water level indicator.

15.6.3 An approved equivalent device for level indication may derive its level input signal from one of the low water level detection systems required by *Pt 5, Ch 10, 15.7 Low water level fuel shut-off and alarm 15.7.1* provided that in the event of a power supply failure to that system an alarm is initiated and the fuel oil supply to the burners, or any other fuel used to fire the boiler, is automatically shut-off. The fuel supply shut-off will only be required if the power supply failure results in the direct reading gauge glass being the only functioning water level indicator.

15.6.4 The water gauges are to be readily accessible and placed so that the water level is clearly visible. The lowest visible parts of water gauges are to be situated at the lowest safe working level.

15.6.5 The level of the highest part of the effective heating surfaces, e.g. combustion chamber top of a horizontal boiler and the furnace crown of a vertical boiler, is to be clearly marked in a position adjacent to the glass water gauge.

15.6.6 The cocks of all water gauges are to be operable from positions free from danger in the event of the glass breaking.

15.7 Low water level fuel shut-off and alarm

15.7.1 Every fired boiler designed to contain water at a specified level is to be fitted with two systems of water level detection which are to be independent of each other, and which will operate an alarm and shut-off automatically the fuel supply to the burners, or any other fuel used to fire the boiler, when the water level falls to a predetermined low level. These level detectors, in addition, may be used for other functions, e.g. high level alarm, feed pump control, etc.

15.8 Feed check valves

15.8.1 Two feed check and stop valves, connected to separate feed lines, are to be provided for all main and auxiliary boilers which are required for essential services. The feed check and stop valves may be connected to a single standpipe at the shell. In the case of steam/steam generators one feed check valve is acceptable provided steam for essential services is simultaneously available from another source.

15.9 Pressure gauges

15.9.1 Each boiler is to be provided with a separate steam pressure gauge.

15.9.2 The gauges are to be placed where they are easily read.

15.10 Blow-down and scum valves

15.10.1 Each boiler is to be fitted with at least one blow-down valve.

Steam Raising Plant and Associated Pressure Vessels **Part 5, Chapter 10**

15.10.2 The blow-down valve is to be attached, wherever practicable, direct to the lower part of the boiler. Where it is not practicable to attach the blow-down valve directly, a steel pipe supported from the boiler may be fitted between the boiler and valve.

15.10.3 The blow-down valve and its connections to the sea need not be more than 38 mm, and is to be not less than 19 mm internal diameter. For cylindrical boilers the size of the valve may be generally 0,0085 times the diameter of the boiler.

15.10.4 Blow-down valves and scum valves (where the latter are fitted) of two or more boilers may be connected to one common discharge, but where thus arranged there are to be screw-down non-return valves fitted for each boiler to prevent the possibility of the contents of one boiler passing to another.

15.10.5 For blow-down valves or cocks on the ship's side and attachments, see *Pt 5, Ch 13, 2 Construction and installation*.

15.11 Sampling valve or cock

15.11.1 Each boiler is to be provided with a sampling valve or cock secured direct to the boiler in a convenient position. The valve or cock is not to be on the water gauge standpipe.

15.12 Additional requirements for shell type exhaust gas steaming economisers

15.12.1 The design and construction of shell type economisers are to pay particular attention to the welding, heat treatment and inspection arrangements at the tube plate connection to the shell.

15.12.2 Every shell type economiser is to be provided with removable lagging at the circumference of the tube end plates to enable ultrasonic examination of the tube plate to shell connection.

15.12.3 Every economiser is to be provided with arrangements for pre-heating and de-aeration, and addition of water treatment or combination thereof, to control the quality of feed water to within the manufacturer's recommendations.

15.12.4 The manufacturer is to provide operating instructions for each economiser which is to include reference to:

- Feed water treatment and sampling arrangements.
- Operating temperatures – exhaust gas and feed water temperatures.
- Operating pressure.
- Inspection and cleaning procedures.
- Records of maintenance and inspection.
- The need to maintain adequate water flow through the economiser under all operating conditions.
- Periodical operational checks of the safety devices to be carried out by the operating personnel and to be documented accordingly.
- Procedures for using the exhaust gas economiser in the dry condition.
- Procedures for maintenance and overhaul of safety valves.
- Emergency operating procedures.

■ *Section 16* **Mountings and fittings for water tube boilers**

16.1 General

16.1.1 Mountings and fittings not mentioned in this Section are to be in accordance with the requirements in *Pt 5, Ch 10, 15 Mountings and fittings for cylindrical and vertical boilers, steam generators, pressurised thermal liquid and pressurised hot water heaters*.

16.2 Safety valves

16.2.1 Water tube boilers are to be fitted with not less than two safety valves of area and design in general accordance with the requirements of *Pt 5, Ch 10, 15.2 Safety valves*.

16.2.2 Each saturated steam drum and each superheater are to be provided with at least one safety valve.

Steam Raising Plant and Associated Pressure Vessels

Part 5, Chapter 10

Section 16

16.2.3 Where the superheater forms an integral part of the boiler, the relieving capacity of the superheater safety valve(s), based on the reduced pressure at the superheater outlet, may be included as part of the total relieving capacity required for the boiler. As some National Authorities limit the proportion of the superheater safety valve relieving capacity which may be credited towards the total capacity for the boiler, builders should give attention to any relevant Statutory Requirements of the National Authority of the country in which the ship is to be registered.

16.2.4 The boiler and superheater valves are to be so disposed and proportioned between saturated steam drum and superheater outlet that the superheater will be protected from overheating under all service conditions, including an emergency stop of the ship at full power.

16.2.5 Where it is proposed to fit full bore safety valves operated by independent pilot valves, the arrangements are to be submitted for consideration. The pipes connecting pilot valves and main valves are to be of ample bore and wall thickness to minimise the possibility of obstruction and damage.

16.2.6 Where it is impracticable to attach safety valves directly to the superheater, the valves are to be located as near as possible thereto and fitted to a branch piece connected to the superheater outlet pipe.

16.2.7 In high temperature installations the drains from safety valves are to be led to a tank or other place where high temperature steam can be safely discharged.

16.3 Safety valve settings

16.3.1 All boiler and superheater safety valves are to be set under steam to their respective working pressures, which are not to be greater than the approved design pressure of the boiler. As a working tolerance the setting is acceptable provided the valves lift at not more than 103 per cent of the approved pressure.

16.3.2 In the setting of superheater safety valves, allowance is to be made for the pressure drop through the superheater so that under discharge conditions the pressure in the boiler will not exceed the approved boiler pressure.

16.3.3 In no case is the superheater safety valve setting to exceed by more than three per cent the pressure for which the steam piping is approved.

16.4 Waste steam pipes

16.4.1 The waste steam pipe and passages leading to it from the safety valves are to be in general accordance with the requirements of *Pt 5, Ch 10, 15.3 Waste steam pipes*.

16.4.2 In installations operating with a high degree of superheat, consideration is to be given to the high temperatures which waste steam pipes, silencers and surrounding spaces will attain when the superheater safety valves are blowing during accumulation tests and in service, adequate protection against heat effects is to be provided to the Surveyor's satisfaction.

16.4.3 Waste steam pipes are to be led well clear of electric cables and any parts or structures sensitive to heat or likely to distort; the pipes are to be insulated where necessary. In these installations each boiler should have a separate waste steam pipe system to atmosphere, with supporting and expansion arrangements such that no direct loading is imposed on the safety valve chests.

16.5 Accumulation tests

16.5.1 Tests for accumulation of pressure are to be carried out with the stop valve closed and under full firing conditions for a period not exceeding seven minutes. The accumulation is not to exceed 10 per cent of the design pressure.

16.5.2 Where accumulation tests might endanger the superheaters, consideration will be given in cases of fired boilers to the omission of these tests, provided that application is made when the boiler plan and sizes of safety valves are submitted for approval, and that the safety valves are of an approved type for which the capacity has been established by test in the presence of the Surveyors or an approved independent authority, or for which LR is satisfied, by long experience of accumulation tests, that the capacity is adequate. When it is agreed to waive accumulation tests, it will be required that the valve makers provide a certificate for each safety valve, stating its rated capacity at the approved working conditions of the boilers and that the boiler makers provide a certificate for each boiler stating its maximum evaporation.

16.5.3 The safety valves are to be found satisfactory in operation under working conditions during the trials of the machinery on board ship.

Steam Raising Plant and Associated Pressure Vessels

Part 5, Chapter 10

16.6 Water level indicators

16.6.1 Every boiler designed to contain water at a specified level is to be fitted with at least two means for indicating its water level, at least one of which is to be a direct reading gauge glass. The other means is to be either an additional gauge glass or an approved equivalent device. The required water level indicators are to be independent of each other.

16.6.2 Where a pair of gauge glasses are set at different levels to provide an extended range of water level indication they will only be considered as one water level indicator.

16.6.3 An approved equivalent device for level indication may derive its level input signal from one of the low water level detection systems required by *Pt 5, Ch 10, 16.7 Low water level fuel shut-off and alarm 16.7.1* provided that, in the event of a power supply failure to that system, an alarm is initiated and the fuel oil supply to the burners, or any other fuel used to fire the boiler, is automatically shut-off. The fuel supply shut-off will only be required if the power supply failure results in the direct reading gauge glass being the only functioning water level indicator.

16.6.4 Where a steam and water drum exceeding 4 m in length is fitted athwartships, two glass water gauges are to be fitted in suitable positions, one near each end of the drum.

16.6.5 The position of the glass water gauge of boilers in which the tubes are entirely drowned when cold is to be such that water is just showing in the glass when the water level in the steam drum is just above the top of the uppermost tubes when the boiler is cold.

16.6.6 In boilers, the tubes of which are not entirely drowned when cold, the glass water gauges are to be placed, to the Surveyor's satisfaction, in the positions which have been found by experience to indicate satisfactorily that the water content is sufficient for safety when the boiler is worked under all service conditions.

16.7 Low water level fuel shut-off and alarm

16.7.1 Every fired boiler designed to contain water at a specified level is to be fitted with two systems of water level detection which are to be independent of each other, and which will operate an alarm and shut off automatically the fuel supply to the burners when the water level falls to a predetermined low level. These level detectors may be used for other functions, e.g. high level alarm, feed pump control, etc.

16.7.2 Any proposals to depart from these requirements in the case of small auxiliary boilers will be the subject of special consideration.

16.7.3 See *Pt 6, Ch 1 Control Engineering Systems* for requirements for control, alarm and safety systems, and additional requirements for unattended operation.

16.8 Feed check valves and water level regulators

16.8.1 Two feed check and stop valves, connected to separate feed lines, are to be provided for each boiler and are to be attached, wherever practicable, direct to the boiler or to an economiser which forms an integral part of the boiler.

16.8.2 Where the arrangements necessitate the use of a common inlet pipe on the economiser for both main and auxiliary feed systems, this pipe is to be as short as practicable, and the arrangements of check valves are to be such that either feed line can be effectively isolated without interruption of the feed water supply to the boiler.

16.8.3 At least one of the feed water systems is to be fitted with an approved feed water regulator whereby the water level in the boilers is controlled automatically. See *Pt 5, Ch 14, 6 Boiler feed water, condensate and thermal fluid circulation systems* for arrangements and details of boiler feed systems.

16.8.4 The feed check valves are to be fitted with efficient gearing, whereby they can be satisfactorily worked from the stokehold floor, or other convenient position.

16.8.5 Standpipes on boilers, for feed inlets, are to be designed with an internal pipe to prevent direct contact between the feed pipe and the boiler shell or end plates with the object of minimising thermal stresses in these plates. Similar arrangements are to be provided for desuperheater and other connections where significant temperature differences occur in service.

■ *Section 17*
Hydraulic tests

17.1 General

17.1.1 Boilers and pressure vessels, together with their components are to withstand the following hydraulic tests without any sign of weakness or defect.

17.1.2 Having regard to the variation in the types and design of boilers, the hydraulic test may be carried out by either of the methods indicated below:

- (a) boilers are to be tested on completion to a pressure 1,5 times the approved design pressure, or
- (b) where construction permits, all components of the boiler are to be tested on completion of the work including heat treatment to 1,5 times the design pressure. In the case of components such as drums or headers, which are to be drilled for tube holes, the test may be before drilling the tube holes, but is to be after the attachment of standpipes, stubs and similar fittings and also after heat treatment has been carried out. Where all the components have been tested as above, each completed boiler after assembly is to be tested to 1,25 times the design pressure.

17.2 Mountings

17.2.1 All boiler mountings are to be subjected to a hydraulic test of twice the approved design pressure with the exception of feed check valves and other mountings connected to the main feed system which are to be tested to 2,5 times the approved boiler design pressure, or twice the maximum pressure which can be developed in the feed line in normal service, whichever is greater.

■ *Section 18*
Control and monitoring

18.1 General

18.1.1 Control engineering systems are to be in accordance with the requirements of *Pt 6, Ch 1 Control Engineering Systems*.

18.2 Unattended machinery

18.2.1 Where boilers are fitted with automatic or remote controls so that under normal operating conditions they do not require any manual intervention by the operators, they are to be provided with the alarms and safety arrangements required by *Pt 5, Ch 10, 18.2 Unattended machinery* to *Pt 5, Ch 10, 18.3 Main, auxiliary and other boilers*, as appropriate. Alternative arrangements which provide equivalent safeguards will be considered.

18.2.2 Where machinery is arranged to start automatically or from a remote control station, interlocks are to be provided to prevent start-up under conditions which could hazard the machinery.

18.2.3 Where machinery specified in this Section is required to be provided with a standby pump, the standby pump is to start automatically if the discharge pressure from the working pumps falls below a predetermined value.

18.2.4 Where a first stage alarm together with a second stage alarm and automatic shutdown of machinery are required in the relevant Tables of this Section, the sensors and circuits utilised for the second stage alarm and automatic shutdown are to be independent of those required for the first stage alarm.

18.3 Main, auxiliary and other boilers

18.3.1 Alarms and safeguards are indicated in *Pt 5, Ch 10, 18.3 Main, auxiliary and other boilers 18.3.2* to *Pt 5, Ch 10, 18.3 Main, auxiliary and other boilers 18.3.9* and *Table 10.18.1 Main, auxiliary and other boilers: Alarms and safeguards*.

Steam Raising Plant and Associated Pressure Vessels **Part 5, Chapter 10**

Table 10.18.1 Main, auxiliary and other boilers: Alarms and safeguards

Item	Alarm	Note
Water level*	Low	Two water level sensors are to be provided, each to operate independently, and automatically to shut off the fuel oil to the burners and operate alarms, see Notes 1 to 3 and 5
Water level	1st stage high	—
	2nd stage high	Where applicable, automatic closure of turbine steam inlet valves, see Pt 5, Ch 10, 18.2 Unattended machinery 18.2.4
Steam drum or superheater outlet pressure*	High and Low	—
Superheated steam temperature	High	—
De-superheated steam temperature*	High	—
Feed water or water forced circulation flow (if fitted)	Low	Fuel oil to burners to be shut off automatically, see Notes 5 and 6
Feed water pH	Low	When automatic dosing of feed water fitted
Feed water salinity	High	Fitted in boiler feed system
Feed water temperature	Low	When automatic temperature control fitted
Combustion air pressure*	Low	Fuel oil burners to be shut off automatically in operation or not released during start up, see Note 5. Purge sequences to be inhibited, see Pt 5, Ch 14, 3.1 Oil burning units 3.1.9
Fuel oil pressure*	Low	—
Fuel oil temperature or viscosity*	High and Low	Heavy oil only
Fuel oil atomising steam/air pressure	Low	—
Burner flame*	Failure	Each burner to be monitored. Fuel oil to burner(s) to be shut off automatically, see Pt 5, Ch 14, 3.1 Oil burning units 3.1.11 and Pt 5, Ch 14, 3.1 Oil burning units 3.1.12 and Note 5
Flame monitoring device(s)*	Failure	See Pt 5, Ch 10, 18.3 Main, auxiliary and other boilers 18.3.7 and Note 5
Igniter power supply*	Failure	Each igniter to be checked before fuel oil is supplied to burner, see Pt 5, Ch 10, 18.3 Main, auxiliary and other boilers 18.3.6 and Note 5
Forced draft fan*	Power failure	Fuel oil to burners to be shut off automatically. Control using alternative arrangements is to remain available, see Pt 6, Ch 1, 2.5 Control systems, general requirements 2.5.7
Air registers and dampers (including those in the uptake)*	Not fully open	Purge sequence to be inhibited, see Pt 5, Ch 14, 3.1 Oil burning units 3.1.9
Control system*	Power failure	Fuel oil burners to be shut off automatically. Control using alternative arrangement is to remain available, see Pt 6, Ch 1, 2.5 Control systems, general requirements 2.5.7

Steam Raising Plant and Associated Pressure Vessels Part 5, Chapter 10

Section 18

Uptake temperature	High	<p>Where economiser and/or gas air heaters are integral with the boiler and also for independent exhaust gas boilers/economisers, to monitor for soot fires.</p> <p>See Note 7</p>
<p>Note 1. For dual-evaporation boilers, the primary circuit is to be fitted with two independent low water level detectors which will operate alarms and shut off the fuel oil to the burners automatically. The secondary circuit is to be fitted with one low water level detector which will operate alarms and shut off the fuel oil to the burners automatically. Additionally one high water level alarm is to be fitted on the secondary circuit which may be operated by the same detector as that provided for low water level detection.</p> <p>Note 2. Only one independent system of low water level detection, alarm and automatic fuel oil shut-off need be fitted in the case of small forced circulation or re-circulation coiled water tube 'package' type boilers when evaporation is less than 2900 kg/hr or the heating surface is less than 100 m².</p> <p>Note 3. Where two level sensors are provided these may be used for other functions, e.g. high level alarm, level control, trip systems, etc.</p> <p>Note 4. For boilers not supplying steam for propulsion or for services essential for the safety or operation of the ship at sea, only the items marked * are required.</p> <p>Note 5. These safeguards are to remain operative during automatic, manual and emergency operation.</p> <p>Note 6. For exhaust gas economisers/boilers requiring feed water or forced water circulation, the low flow alarm is to be fitted with provision to override the alarm if the exhaust gas economiser/boiler is to be operated in the dry condition. See also Pt 5, Ch 14, 6.2 Feed and circulation pumps 6.2.5.</p> <p>Note 7. Alternatively, details of an appropriate fire detection system are to be submitted for consideration.</p>		

18.3.2 The following boiler services are to be fitted with automatic controls so as to maintain steady state conditions throughout the normal operating range of the boiler:

- (a) Combustion system.
- (b) Fuel oil supply temperature or viscosity, heavy oil only.
- (c) Boiler drum water level.
- (d) De-aerator water level, where applicable.
- (e) Superheated steam pressure, where applicable.
- (f) Superheated steam temperature, where applicable.
- (g) De-superheated steam pressure, where applicable.
- (h) De-superheated steam temperature, where applicable.

18.3.3 Safety systems and overrides are to comply with the requirements of Pt 6, Ch 1, 2.4 Safety systems, general requirements 2.4.8.

18.3.4 Burner controls are to be arranged such that light off is only possible at the minimum firing rate compatible with flame establishment. If ignition is set to occur at a fuel rich condition then the burner is to revert to the correct operating air/fuel ratio on establishment of a stable flame.

18.3.5 Where water level indicators are dependent upon an external power supply, the fuel oil supply to the burners is to be automatically shut off in the event of power or signal failure.

18.3.6 Arrangements are to be such that burner fuel oil valve(s) do not open:

- (a) prior to completion of required warm up times for residual fuel oil; or
- (b) when the power supply to the igniter has failed, as applicable; or
- (c) until a pilot flame is established, as applicable; or
- (d) prior to the completion of furnace purging, see Pt 5, Ch 14, 3.1 Oil burning units 3.1.7.

18.3.7 Arrangements for flame failure detection are to be provided with self-monitoring capabilities which ensure that the flame detector is not erroneously indicating the presence of a flame. In the event of failure being detected by these self-monitoring capabilities:

- an alarm is to be activated;
- in the event of loss of flame detection capability for a burner;

Steam Raising Plant and Associated Pressure Vessels **Part 5, Chapter 10**

Section 18

- fuel oil to the burner is to be shut off automatically; and
- an alarm is to be activated.

18.3.8 Where established as necessary by *Pt 5, Ch 14, 3.1 Oil burning units 3.1.8*, means are to be provided to prevent starting of the ignition sequence following multiple flame failures until completion of the identified lock-out period.

18.3.9 Following burner shutdown, the furnace is to be purged automatically for at least the required pre-purging time. In the event of shutdown due to activation of a required safeguard, this purging is to be manually initiated.

Section

-
- 1 **General requirements**
 - 2 **Cylindrical shells and drums subject to internal pressure**
 - Cross-references**
 - 3 **Spherical shells subject to internal pressure**
 - 4 **Dished ends subject to internal pressure**
 - Cross-references**
 - 5 **Dished ends for Class 3 pressure vessels**
 - 6 **Conical ends subject to internal pressure**
 - 7 **Standpipes and branches**
 - 8 **Construction**
 - Cross-references**
 - 9 **Mountings and fittings**
 - Cross-references**
 - 10 **Hydraulic tests**
 - 11 **Plate heat exchangers**
-

■ **Section 1**
General requirements

1.1 Application

1.1.1 The requirements of this Chapter are applicable to fusion welded pressure vessels and plate heat exchangers, intended for marine purposes but not included in *Pt 5, Ch 10 Steam Raising Plant and Associated Pressure Vessels*. The equations in this Chapter may be used for determining the thickness of seamless pressure vessels using a joint factor of 1,0. Seamless pressure vessels are to be manufactured and tested in accordance with the requirements of *Ch 5 Steel Forgings* of the *Rules for the Manufacture, Testing and Certification of Materials* (hereinafter referred to as the Rules for Materials). For the construction and design of pressure vessels and plate heat exchangers for liquefied gas or chemical cargo applications, see the *18 Rules and Regulations for the Construction and Classification of Ships for the Carriage of Liquefied Gases in Bulk, July 2015* (hereinafter referred to as the Rules for Ships of Liquid Gases) or the *Rules and Regulations for the Construction and Classification of Ships for the Carriage of Liquid Chemicals in Bulk, July 2015* (hereinafter referred to as the Rules for Ships of Liquid Chemicals) as applicable.

1.1.2 Where the required design criteria for pressure vessels are not indicated within this Chapter, the relevant Sections of *Pt 5, Ch 10 Steam Raising Plant and Associated Pressure Vessels* are applicable.

1.1.3 Seamless pressure vessels are to be manufactured in accordance with the requirements of the *Rules for the Manufacture, Testing and Certification of Materials, July 2015* where applicable.

1.2 Definition of symbols

1.2.1 The symbols used in the various formulae in *Pt 5, Ch 11, 2 Cylindrical shells and drums subject to internal pressure* to *Pt 5, Ch 11, 7 Standpipes and branches* inclusive, unless otherwise stated, are defined as follows, and are applicable to the specific part of the pressure vessel under consideration:

d = diameter of hole, or opening, in mm

p = design pressure, see Pt 5, Ch 11, 1.3 Design pressure, in bar

r_i = inside knuckle radius, in mm

r_o = outside knuckle radius, in mm

s = pitch, in mm

t = minimum thickness, in mm

D_i = inside diameter, in mm

D_o = outside diameter, in mm

J = joint factor applicable to welded seams, see Pt 5, Ch 11, 1.9 Joint factors, or ligament efficiency between tube holes (expressed as a fraction, see Pt 5, Ch 10, 2.2 Efficiency of ligaments between tube holes)

R_i = inside radius, in mm

R_o = outside radius, in mm

T = design temperature, in °C

σ = allowable stress, see Pt 5, Ch 11, 1.8 Allowable stress, in N/mm².

1.2.2 Where reference is made to calculated or actual plate thickness for the derivation of other values, these thicknesses are to be minus the standard Rule corrosion allowance of 0,75 mm, if not so stated.

1.3 Design pressure

1.3.1 The design pressure is the maximum permissible working pressure, and is to be not less than the highest set pressure of any relief valve.

1.3.2 Calculations made to determine the scantlings of the pressure parts are to be based on the design pressure, adjusted where necessary to take account of pressure variations corresponding to the most severe operational conditions.

1.3.3 It is desirable that there should be a margin between the normal pressure at which the pressure vessel operates and the lowest pressure at which any relief valve is set to lift, to prevent unnecessary lifting of the relief valve.

1.4 Metal temperature

1.4.1 The metal temperature, T , used to evaluate the allowable stress, σ , is to be taken as the actual metal temperature expected under operating conditions for the pressure part concerned, and is to be stated by the manufacturer when plans of the pressure parts are submitted for consideration.

1.4.2 The design temperature, T , for calculation purposes is to be not less than 50°C.

1.5 Classification of fusion welded pressure vessels

1.5.1 For Rule purposes, pressure vessels are graded as Class 1 where the shell thickness exceeds 38 mm.

1.5.2 For Rule purposes, pressure vessels are graded as Class 2/1 and Class 2/2 if they comply with the following conditions:

- (a) where the design pressure exceeds 17,2 bar, or
- (b) where the metal temperature exceeds 150°C, or
- (c) where the design pressure, in bar, multiplied by the actual thickness of the shell, in mm, exceeds 157, or
- (d) where the shell thickness does not exceed 38 mm.

1.5.3 For Rule purposes, Class 3 pressure vessels are to have a maximum shell thickness of 16 mm, and are pressure vessels not included in Classes 1, 2/1 or 2/2.

1.5.4 Pressure vessels which are constructed in accordance with Classes 2/1, 2/2 or 3 standards (as indicated above) will, if manufactured in accordance with the requirements of superior Class, be approved with the scantlings appropriate to that Class.

1.5.5 Pressure vessels which have only circumferential fusion welded seams, will be considered as seamless with no Class being assigned. Preliminary weld procedure tests and non-destructive examination for the circumferential seam welds should be carried out for the equivalent Class as determined by *Pt 5, Ch 11, 1.5 Classification of fusion welded pressure vessels 1.5.1, Pt 5, Ch 11, 1.5 Classification of fusion welded pressure vessels 1.5.2* and *Pt 5, Ch 11, 1.5 Classification of fusion welded pressure vessels 1.5.3*.

1.5.6 In special circumstances relating to service conditions, materials, operating temperature, the carriage of dangerous gases and liquids, etc. it may be required that certain pressure vessels be manufactured in accordance with the requirements of a superior Class.

1.5.7 Details of heat treatment, non-destructive examination and routine tests (where required) are given in *Ch 13 Requirements for Welded Construction* of the Rules for Materials.

1.5.8 Hydraulic testing is required for all Classes of pressure vessels.

1.5.9 For a full definition of Classes of pressure vessels relating to boilers and associated pressure vessels, see *Pt 5, Ch 10, 1 General requirements*.

1.6 Plans

1.6.1 Plans of pressure vessels are to be submitted in triplicate for consideration where all the conditions in *Pt 5, Ch 11, 1.6 Plans 1.6.1* or *Pt 5, Ch 11, 1.6 Plans 1.6.1* are satisfied:

(a) The vessel contains vapours or gases, e.g. air receivers, hydrophore or similar vessels and gaseous CO₂ vessels for fire-fighting, and

$$pV > 600$$

$$p > 1$$

$$V > 100$$

V = volume (litres) of gas or vapour space

(b) The vessel contains liquefied gases, or flammable liquids

$$p > 7$$

$$V > 100$$

V = volume (litres)

p is as defined in *Pt 5, Ch 11, 1.2 Definition of symbols 1.2.1*.

1.6.2 Plans of full constructional features of the vessel and dimensional details of the weld preparations for longitudinal and circumferential seams and attachments, together with particulars of the welding consumables and of the mechanical properties of the materials, are to be submitted before construction is commenced.

1.7 Materials

1.7.1 Materials used in the construction of Class 1, 2/1 and 2/2 pressure vessels are to be manufactured, tested and certified in accordance with the requirements of the Rules for Materials. Materials used in the construction of Class 3 pressure vessels may be in accordance with the requirements of an acceptable national or international specification. The manufacturer's certificate will be accepted in lieu of Lloyd's Register (hereinafter referred as 'LR') material certificate for such materials.

1.7.2 The specified minimum tensile strength of carbon and carbon-manganese steel plates, pipes, forgings and castings is to be within the general limits of 340 to 520 N/mm²:

1.7.3 The specified minimum tensile strength of low alloy steel plates, pipes, forgings and castings is to be within the general limits of 400 to 500 N/mm², and pressure vessels made in these steels are to be either seamless or Class 1 fusion welded.

1.7.4 Where it is proposed to use materials other than those specified in the Rules for Materials, details of the chemical compositions, heat treatment and mechanical properties are to be submitted for approval. In such cases, the values of the mechanical properties used for deriving the allowable stress are to be subject to agreement by LR.

1.8 Allowable stress

1.8.1 The term 'allowable stress', σ , is the stress to be used in the formulae for the calculation of scantlings of pressure parts.

1.8.2 The allowable stress, σ , is to be the lowest of the following values:

$$\sigma = \frac{E_t}{1,5} \quad \sigma = \frac{R_{20}}{2,7} \quad \sigma = \frac{S_R}{1,5}$$

where

E_t = specified minimum lower yield stress or 0,2 per cent proof stress at temperature, T , for carbon and carbon-manganese steels. In the case of austenitic steels, the 1,0 per cent proof stress at temperature, T , is to be used

R_{20} = specified minimum tensile strength at room temperature

S_R = average stress to produce rupture in 100 000 hours at temperature, T

T = metal temperature, see *Pt 5, Ch 11, 1.4 Metal temperature*.

1.8.3 The allowable stress for steel castings is to be taken as 80 per cent of the value determined by the method indicated in *Pt 5, Ch 11, 1.8 Allowable stress 1.8.2* using the appropriate values for cast steel.

1.8.4 Where steel castings, which have been tested in accordance with the *Rules for the Manufacture, Testing and Certification of Materials, July 2015* are also subjected to non-destructive tests, consideration will be given to increasing the allowable stress using a factor up to 90 per cent in lieu of the 80 per cent referred to in *Pt 5, Ch 11, 1.8 Allowable stress 1.8.3*. Particulars of the non-destructive test proposals are to be submitted for consideration.

1.9 Joint factors

1.9.1 The following joint factors are to be used in the equations in *Pt 5, Ch 11, 2 Cylindrical shells and drums subject to internal pressure*, where applicable. Fusion welded pressure parts are to be made in accordance with *Pt 5, Ch 17 Requirements for Fusion Welding of Pressure Vessels and Piping*.

Class of pressure vessel	Joint factor
Class 1	1,0
Class 2/1	0,85
Class 2/2	0,75
Class 3	0,60

1.9.2 The longitudinal joints for all Classes of vessels are to be butt joints. Circumferential joints for Class 1 vessels are also to be butt welds. Circumferential joints for Classes 2/1, 2/2 and 3 vessels should also be butt joints with the following exceptions:

- (a) Circumferential joints for Classes 2/1, 2/2 and 3 vessels may be of the joggle type provided neither plate at the joints exceeds 16 mm thickness.
- (b) Circumferential joints for Class 3 vessels may be of the lap type provided neither plate at the joint exceeds 16 mm thickness nor the internal diameter of the vessel exceeds 610 mm.

For typical acceptable methods of attaching flat ends see *Figure 10.8.2 Typical methods of attachment of header end closures* and *Figure 10.9.1 Typical attachment of unflanged flat end plates to shell* in Chapter 10.

For typical acceptable methods of attaching dished ends see *Figure 11.8.1 Typical attachment of dished ends to cylindrical shell*.

1.9.3 Where a pressure vessel is to be made of alloy steel, particulars of the welding consumables to be used, including typical mechanical properties and chemical composition of the deposited weld metal, are to be submitted for approval.

1.10 Pressure parts of irregular shape

1.10.1 Where pressure parts are of such irregular shape that it is impracticable to design their scantlings by the application of the formulae in *Pt 5, Ch 11, 2 Cylindrical shells and drums subject to internal pressure*, the suitability of their construction is to be determined by hydraulic proof test of a prototype or by an agreed alternative method.

1.11 Adverse working conditions

1.11.1 Where working conditions are adverse, special consideration may require to be given to increasing the scantlings derived from the formulae. In this connection, where necessary, account should also be taken of any excess of loading resulting from:

- (a) impact loads, including rapidly fluctuating pressures,
- (b) weight of the vessel and normal contents under operating and test conditions,
- (c) superimposed loads, such as other pressure vessels, operating equipment, insulation, corrosion-resistant or erosion-resistant linings and piping,
- (d) reactions of supporting lugs, rings, saddles or other types of supports, or
- (e) the effect of temperature gradients on maximum stress.

■ *Section 2*

Cylindrical shells and drums subject to internal pressure**2.1 Minimum thickness**

2.1.1 The minimum thickness, t , of a cylindrical shell is to be determined by the following formula:

$$t = \frac{pR_i}{10\sigma J - 0,5p} + 0,75 \text{ mm}$$

where

$t, p, R_i =$ and σ are as defined in *Pt 5, Ch 11, 1.2 Definition of symbols*

$J =$ the joint factor of the longitudinal joints (expressed as a fraction). See *Pt 5, Ch 11, 1.9 Joint factors* in the case of seamless shells clear of openings $J = 1,0$.

2.1.2 The formula in *Pt 5, Ch 11, 2.1 Minimum thickness 2.1.1* is applicable only where the resulting thickness does not exceed half the internal radius, i.e. where R_o is not greater than $1,5 R_i$.

2.1.3 Irrespective of the thickness determined by the formula in *Pt 5, Ch 11, 2.1 Minimum thickness 2.1.1*, t is to be not less than $3 + \frac{D_i}{1500}$ mm, where D_i is as defined in *Pt 5, Ch 11, 1.2 Definition of symbols*. The minimum thickness permitted for vessels manufactured in corrosion resistant steels will be the subject of special consideration.

■ **Cross-references**

For efficiency of ligaments between tube holes, see *Pt 5, Ch 10, 2.2 Efficiency of ligaments between tube holes*.

For compensating effect of tube stubs, see *Pt 5, Ch 10, 2.3 Compensating effect of tube stubs*.

For unreinforced openings, see *Pt 5, Ch 10, 2.4 Unreinforced openings*.

For reinforced openings, see *Pt 5, Ch 10, 2.5 Reinforced openings*.

■ *Section 3*

Spherical shells subject to internal pressure

3.1 Minimum thickness

3.1.1 The minimum thickness, t , of a spherical shell is to be determined by the following formula:

$$t = \frac{pR_i}{20\sigma J - 0,5p} + 0,75\text{mm}$$

where

t, p, R_i, σ = are as defined in Pt 5, Ch 11, 1.2 Definition of symbols.
and J

3.1.2 The formula in Pt 5, Ch 11, 3.1 Minimum thickness 3.1.1 is applicable only where the resulting thickness does not exceed half the internal radius.

3.1.3 Irrespective of the thickness determined by the formula in Pt 5, Ch 11, 3.1 Minimum thickness 3.1.1, t is to be not less than $3 + \frac{D_i}{1500}$ mm, where D_i is as defined in Pt 5, Ch 11, 1.2 Definition of symbols. The minimum thickness permitted for vessels manufactured in corrosion resistant steels will be the subject of special consideration.

3.1.4 Openings in spherical shells requiring compensation are to comply, in general, with Pt 5, Ch 10, 2.5 Reinforced openings, using the calculated and actual thickness of the spherical shell as applicable.

■ *Section 4*

Dished ends subject to internal pressure

4.1 Minimum thickness

4.1.1 The thickness, t , of semi-ellipsoidal and hemispherical unstayed ends, and the knuckle section of torispherical ends, dished from plate, having pressure on the concave side and satisfying the conditions listed below, is to be determined by the following formula:

$$t = \frac{pD_o K}{20\sigma J} + 0,75\text{mm}$$

where

t, p, D_o, σ = are as defined in Pt 5, Ch 11, 1.2 Definition of symbols
and J

K = a shape factor, see Pt 5, Ch 10, 4.2 Shape factors for dished ends and Figure 10.4.1 Shape factor.

4.1.2 For semi-ellipsoidal ends:

the external height, $H \geq 0,18D_o$

where

D_o = the external diameter of the parallel portion of the end, in mm.

4.1.3 For torispherical ends:

the internal radius, $R_i \leq D_o$

the internal knuckle radius, $r_i \geq 0,1D_o$

the internal knuckle radius, $r_i \geq 3t$

the external height, $H \geq 0,18D_o$, and is determined as follows:

$$H = R_o - \sqrt{(R_o - 0,5D_o)(R_o + 0,5D_o - 2r_o)}$$

4.1.4 In addition to the formula in *Pt 5, Ch 11, 4.1 Minimum thickness 4.1.1* the thickness, t , of a torispherical head, made from more than one plate, in the crown section, is to be not less than that determined by the following formula:

$$t = \frac{pR_i}{20\sigma J - 0,5p} + 0,75\text{mm}$$

= where t , p , R_i , σ , and J are as defined in *Pt 5, Ch 11, 1.2 Definition of symbols*.

4.1.5 The thickness required by *Pt 5, Ch 11, 4.1 Minimum thickness 4.1.1* for the knuckle section of a torispherical head is to extend past the common tangent point of the knuckle and crown radii into the crown section for a distance not less than $0,5\sqrt{R_i t}$ mm, before reducing to the crown thickness permitted by *Pt 5, Ch 11, 4.1 Minimum thickness 4.1.4*

where

t = the required thickness from *Pt 5, Ch 11, 4.1 Minimum thickness 4.1.1*.

4.1.6 In all cases, H is to be measured from the commencement of curvature, shown in *Figure 10.4.2 Typical dished ends*.

4.1.7 The minimum thickness of the head, t , is in no case to be less than $3 + \frac{D_i}{1500}$ mm, where D_i is as defined in *Pt 5, Ch 11, 1.2 Definition of symbols*. The minimum thickness permitted for vessels manufactured in corrosion resistant steels will be the subject of special consideration.

4.1.8 For ends which are butt welded to the drum shell, see *Pt 5, Ch 11, 1.9 Joint factors*, the thickness of the edge of the flange for connection to the shell is to be not less than the thickness of an unpierced seamless or welded shell, whichever is applicable, of the same diameter and material and determined by *Pt 5, Ch 11, 2.1 Minimum thickness*.



Cross-references

For shape factors for dished ends, see *Pt 5, Ch 10, 4.2 Shape factors for dished ends*.

For dished ends with unreinforced openings, see *Pt 5, Ch 10, 4.3 Dished ends with unreinforced openings*.

For flanged openings in dished ends, see *Pt 5, Ch 10, 4.4 Flanged openings in dished ends*.

For location of unreinforced and flanged openings in dished ends, see *Pt 5, Ch 10, 4.5 Location of unreinforced and flanged openings in dished ends*.

For dished ends with reinforced openings, see *Pt 5, Ch 10, 4.6 Dished ends with reinforced openings* and *Pt 5, Ch 10, 4.7 Torispherical dished ends with reinforced openings*.



Section 5

Dished ends for Class 3 pressure vessels

5.1 Minimum thickness

5.1.1 As an alternative to the formula in *Pt 5, Ch 11, 4.1 Minimum thickness 4.1.1*, for Class 3 vessels only, the minimum thickness, t , of a torispherical unstayed end dished from plate and having pressure on the concave or convex side is to be determined by the following formula:

$$t = \frac{pR_i}{CS}$$

where

$t, p,$ and R_i = are as defined in Pt 5, Ch 11, 1.2 Definition of symbols

C = 2,57 for ends concave to pressure

= 1,65 for ends convex to pressure

S = specified minimum tensile strength of plate, in N/mm², which should be not less than 410 N/mm².

5.1.2 The inside radius of curvature, R_i , of the end plate is to be not greater than the external diameter of the cylinder to which it is attached.

5.1.3 The inside knuckle radius, r_i , of the arc joining the cylindrical flange to the spherical surface of the end is to be not less than four times the thickness of the end plate, and in no case less than 65 mm.

5.1.4 Ends convex to pressure are not to be used for vessels exceeding 610 mm internal diameter.

5.1.5 Where the end is provided with a flanged manhole, the thickness of the end, in mm, determined by Pt 5, Ch 11, 5.1 Minimum thickness 5.1.1, is to be increased by 3 mm, and the total depth, H , of the manhole flange, measured from the outer surface of the plate on the minor axis, is to be not less than :

$$H = \sqrt{t_1 W}$$

where

t_1 = required thickness of the plate, in mm

H = depth of flange, in mm

W = minor axis of the manhole, in mm.

■ Section 6 Conical ends subject to internal pressure

6.1 General

6.1.1 Conical ends and conical reducing sections, as shown in Figure 10.5.1 Conical ends and conical reducing sections in Pt 5, Ch 10 Steam Raising Plant and Associated Pressure Vessels, are to be designed in accordance with the equations given in Pt 5, Ch 11, 6.2 Minimum thickness.

6.1.2 Connections between cylindrical shell and conical sections and ends should preferably be by means of a knuckle transition radius. Typical permitted details are shown in Figure 10.5.1 Conical ends and conical reducing sections in Pt 5, Ch 10 Steam Raising Plant and Associated Pressure Vessels. Alternatively, conical sections and ends may be butt welded to cylinders without a knuckle radius when the change in angle of slope, ψ , between the two sections under consideration does not exceed 30°.

6.1.3 Conical ends may be constructed of several ring sections of decreasing thickness as determined by the corresponding decreasing diameter.

6.2 Minimum thickness

6.2.1 The minimum thickness, t , of the cylinder, knuckle and conical section at the junction and within the distance L from the junction is to be determined by the following formula:

$$t = \frac{pD_o K}{20 \sigma J} + 0,75\text{mm}$$

where

= t, p, σ and J are as defined in Pt 5, Ch 11, 1.2 Definition of symbols

where

D_o = outside diameter, in mm of the conical section or end, see *Figure 10.5.1 Conical ends and conical reducing sections*

K = a factor, taking into account the stress in the knuckle, see *Table 10.5.1 Values of K as a function of ψ and r/D_o* .

6.2.2 If the distance of a circumferential seam from the knuckle or junction is not less than L , then J is to be taken as 1,0; otherwise J is to be taken as the weld joint factor appropriate to the circumferential seam,

where

r_i = inside radius of transition knuckle, in mm, which is to be taken as $0,01D_o$ in the case of conical sections without knuckle transition

L = distance, in mm, from knuckle or junction within which meridional stresses determine the required thickness, see *Figure 10.5.1 Conical ends and conical reducing sections in Pt 5, Ch 10 Steam Raising Plant and Associated Pressure Vessels*

$$= 0,5\sqrt{\frac{D_o t}{\cos \psi}}$$

ψ = difference between angle of slope of two adjoining conical sections, see *Figure 10.5.1 Conical ends and conical reducing sections in Pt 5, Ch 10 Steam Raising Plant and Associated Pressure Vessels*.

6.2.3 The minimum thickness, t , of those parts of conical sections not less than a distance L from the junction with a cylinder or other conical section, is to be determined by the following formula:

$$t = \frac{pD_c}{20\sigma J - p} \frac{1}{\cos \alpha} + 0,75 \text{ mm}$$

where

D_c = inside diameter, in mm, of conical section or end at the position under consideration, see *Figure 10.5.1 Conical ends and conical reducing sections in Pt 5, Ch 10 Steam Raising Plant and Associated Pressure Vessels*

$\alpha, \alpha_1, \alpha_2$ = angle of slope of conical section (at the point under consideration) to the vessel axis, see *Figure 10.5.1 Conical ends and conical reducing sections in Pt 5, Ch 10 Steam Raising Plant and Associated Pressure Vessels*.

6.2.4 The thickness of conical sections having an angle of inclination to the vessel axis of more than 75° is to be determined as for a flat plate.

■ **Section 7**
Standpipes and branches

7.1 Minimum thickness

7.1.1 The minimum wall thickness, t , of standpipes and branches is to be not less than the greater of the two values determined by the following formulae, making such additions as may be necessary on account of bending, static loads and vibrations:

$$t = \frac{pD_o}{20\sigma + p} + 0,75 \text{ mm, or}$$

$$t = 0,015D_o + 3,2 \text{ mm}$$

= where t, p, D_o and σ are defined in *Pt 5, Ch 11, 1.2 Definition of symbols*.

If the second formula applies, the thickness need only be maintained for a length, L , from the outside surface of the vessel, but need not extend past the first connection, butt weld or flange, where:

$$L = 3,5\sqrt{D_o t} \text{ mm}$$

7.1.2 In no case need the wall thickness exceed the minimum shell thickness as required by Pt 5, Ch 11, 2.1 *Minimum thickness*, Pt 5, Ch 11, 3.1 *Minimum thickness* or Pt 5, Ch 11, 4.1 *Minimum thickness* as applicable.

■ Section 8 Construction

8.1 Access arrangements

8.1.1 Pressure vessels are to be so made that the internal surfaces may be examined. Wherever practicable, the openings for this purpose are to be sufficiently large for access and for cleaning the inner surfaces.

8.1.2 Manholes in cylindrical shells should preferably have their shorter axes arranged longitudinally.

8.1.3 Doors for manholes and sightholes are to be formed from steel plate or of other approved construction, and all jointing surfaces are to be machined.

8.1.4 Doors of the internal type are to be provided with spigots which have a clearance of not more than 1,5 mm all round, i.e. the axes of the opening are not to exceed those of the door by more than 3 mm. The width of the manhole gasket seat is not to be less than 16 mm.

8.1.5 Doors of the internal type for openings not larger than 230 x 180 mm need be fitted with only one stud, which may be forged integral with the door. Doors for openings larger than 230 mm x 180 mm are to be fitted with two studs or bolts. The strength of the attachment to the door is not to be less than the strength of the stud or bolt.

8.1.6 The crossbars or dogs for doors are to be of steel.

8.1.7 External circular flat cover plates are to be in accordance with a Recognised Standard.

8.2 Torispherical and semi-ellipsoidal ends

8.2.1 For typical acceptance types of attachment for dished ends to cylindrical shells, see *Figure 11.8.1 Typical attachment of dished ends to cylindrical shell*. Types (d) and (e) are to be made a tight fit in the cylindrical shell.

8.2.2 Where the difference in thickness is the same throughout the circumference, the thicker plate is to be reduced in thickness by machining to a taper for a distance not less than four times the offset, so that the two plates are of equal thickness at the position of the circumferential weld. A parallel portion may be provided between the end of the taper and the weld edge preparation; alternatively, if so desired, the width of the weld may be included as part of the smooth taper of the thicker plate.

8.2.3 The thickness of the plates at the position of the circumferential weld is to be not less than that of an unpierced cylindrical shell of seamless or welded construction, whichever is applicable, of the same diameter and material, see Pt 5, Ch 11, 2.1 *Minimum thickness*.

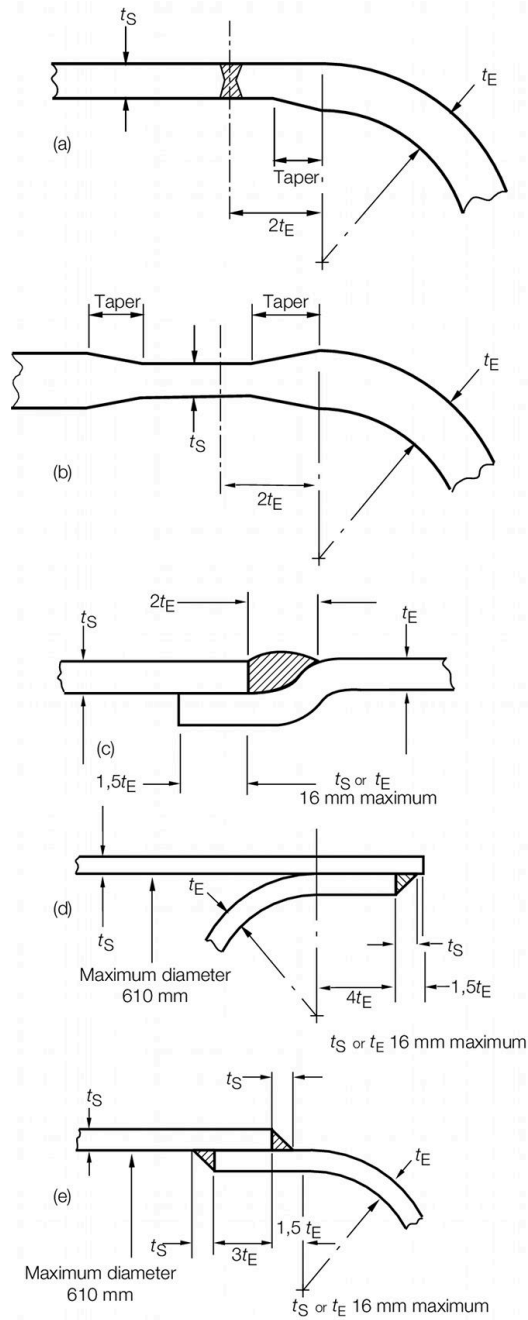

Type of end attachment	Acceptable for
(a) and (b)	All classes
(c)	2/1, 2/2 and 3
(d) and (e)	Class 3 only

2665/23

Figure 11.8.1 Typical attachment of dished ends to cylindrical shell

**Cross-references**

For hemispherical ends, see *Pt 5, Ch 10, 14.3 Hemispherical ends*.

For openings in flat ends, see *Pt 5, Ch 10, 8.4 Header ends*.

For unstayed circular flat end plates, see *Pt 5, Ch 10, 8.4 Header ends*.

For welded-on flanges, butt joints and fabricated branch pieces, see *Pt 5, Ch 10, 14.4 Welded-on flanges, butt welded joints and fabricated branch pieces*.

For welded attachments to pressure vessels, see *Pt 5, Ch 10, 14.5 Welded attachments to pressure vessels*.

*Section 9***Mountings and fittings****9.1 General**

9.1.1 Each pressure vessel or system is to be fitted with a stop valve situated as close as possible to the shell.

9.1.2 Adequate arrangements are to be provided to prevent over-pressure of any part of a pressure vessel which can be isolated. Pressure gauges are to be fitted in positions where they can be easily read.

9.1.3 Adequate arrangements are to be provided for draining and venting the separate parts of each pressure vessel.

9.2 Receivers containing pressurised gases

9.2.1 Each air receiver is to be fitted with a drain arrangement at its lowest part, permitting oil and water to be blown out.

9.2.2 Each receiver which can be isolated from a relief valve is to be provided with a suitable fusible plug to discharge the contents in case of fire. The melting point of the fusible plug is to be approximately 150°C, see also *Pt 5, Ch 11, 9.2 Receivers containing pressurised gases 9.2.3* and *Pt 5, Ch 11, 9.2 Receivers containing pressurised gases 9.2.4*.

9.2.3 Where a fixed system utilising fire-extinguishing gas is fitted, to protect a machinery space containing an air receiver(s), fitted with a fusible plug, it is recommended that the discharge from the fusible plug be piped to the open deck.

9.2.4 Receivers used for the storage of air for the control of remotely operated valves are to be fitted with relief valves and not fusible plugs.

**Cross-references**

For starting air pipe systems and safety fittings, see *Pt 5, Ch 2, 8 Piping*.

For mountings for liquefied gas vessels, see the *18 Rules and Regulations for the Construction and Classification of Ships for the Carriage of Liquefied Gases in Bulk, July 2015*.

■ *Section 10*
Hydraulic tests

10.1 General

10.1.1 Pressure vessels covered by this Chapter are to be tested on completion to a pressure, p_T , determined by the following formula, without showing signs of weakness or defect:

$$p_T = 1,3 \frac{\sigma_{50}}{\sigma_T} \frac{t}{(t - 0,75)} p$$

= but in no case is to exceed

$$= 1,5 \frac{t}{(t - 0,75)} p$$

where

p = design pressure, in bar

p_T = test pressure, in bar

t = nominal thickness of shell as indicated on the plan, in mm

σ_T = allowable stress at design temperature, in N/mm²

σ_{50} = allowable stress at 50°C, in N/mm².

10.2 Mountings

10.2.1 Mountings are to be subjected to a hydraulic test of twice the approved design pressure.

■ *Section 11*
Plate heat exchangers

11.1 General

11.1.1 Plate heat exchangers are to be classed as follows. Class 2 where either of the following conditions apply:

- (a) the maximum metal design temperature is 150°C or greater, or
- (b) design pressure is 17,2 bar or greater.

Class 3 in all other cases.

11.1.2 Where the design temperature is equal to or lower than minus 10°C, a higher class is to apply.

Section

- 1 **General**
- 2 **Carbon and low alloy steels**
- 3 **Copper and copper alloys**
- 4 **Cast iron**
- 5 **Plastics pipes**
- 6 **Valves**
- 7 **Flexible hoses**
- 8 **Hydraulic tests on pipes and fittings**
- Cross-reference**
- 9 **Piping for LPG/LNG carriers, gas fuelled ships and classed refrigeration systems**
- 10 **Austenitic stainless steels**
- 11 **Appendix - Guidance notes on metal pipes for water services**

■ *Section 1*
General

1.1 Application

1.1.1 The requirements of this Chapter apply to the design and construction of piping systems, including pipe fittings forming parts of such systems.

1.1.2 The materials used for pipes, valves and fittings are to be suitable for the medium and the service for which the piping is intended.

1.1.3 The piping systems for LPG and LNG carriers, gas fuelled ships and classed refrigeration systems are to comply with the relevant Sections of this Chapter where applicable and the additional requirements in *Pt 5, Ch 12, 9 Piping for LPG/LNG carriers, gas fuelled ships and classed refrigeration systems* as well as the requirements contained in the *18 Rules and Regulations for the Construction and Classification of Ships for the Carriage of Liquefied Gases in Bulk, July 2015* (hereinafter referred to as the Rules for Ships for Liquefied Gases).

1.2 Definitions

1.2.1 **Piping system** includes pipes and fittings such as expansion joints, valves, pipe joints, support arrangements, flexible tube lengths, etc. and components in direct connection with the piping such as pumps, heat exchangers, air receivers, independent tanks, etc.

1.3 Design symbols

1.3.1 The symbols used in this Chapter are defined as follows:

a = percentage negative manufacturing tolerance on thickness

c = corrosion allowance, in mm

d = inside diameter of pipe, in mm, see *Pt 5, Ch 12, 1.3 Design symbols 1.3.3*

e = weld efficiency factor, see *Pt 5, Ch 12, 1.3 Design symbols 1.3.4*

p = design pressure, in bar (kgf/cm²), see Pt 5, Ch 12, 1.4 Design pressure

p_t = hydraulic test pressure, in bar (kgf/cm²)

t = the minimum thickness of a straight pipe, in mm, including corrosion allowance and negative tolerance, where applicable

t_b = the minimum thickness of a straight pipe to be used for a pipe bend, in mm, including bending allowance, corrosion allowance and negative tolerance, where applicable

D = outside diameter of pipe, in mm, see Pt 5, Ch 12, 1.3 Design symbols 1.3.2

R = radius of curvature of a pipe bend at the centreline of the pipe, in mm

T = design temperature, in °C, see Pt 5, Ch 12, 1.5 Design temperature

σ = maximum permissible design stress, in N/mm² (kgf/cm²).

1.3.2 The outside diameter, D , is subject to manufacturing tolerances, but these are not to be used in the evaluation of formulae.

1.3.3 The inside diameter, d , is not to be confused with nominal size, which is an accepted designation associated with outside diameters of standard rolling sizes.

1.3.4 The weld efficiency factor, e , is to be taken as 1 for seamless and electric resistance and induction welded steel pipes. Where other methods of pipe manufacture are proposed, the value of e will be specially considered.

1.4 Design pressure

1.4.1 The design pressure, p , is the maximum permissible working pressure and is to be not less than the highest set pressure of the safety valve or relief valve.

1.4.2 In water tube boiler installations, the design pressure for steam piping between the boiler and integral superheater outlet is to be taken as the design pressure of the boiler, i.e. not less than the highest set pressure of any safety valve on the boiler drum. For piping leading from the superheater outlet, the design pressure is to be taken as the highest set pressure of the superheater safety valves.

1.4.3 The design pressure of feed piping and other piping on the discharge from pumps is to be taken as the pump pressure at full rated speed against a shut valve. Where a safety valve or other protective device is fitted to restrict the pressure to a lower value than the shut valve load, the design pressure is to be the highest set pressure of the device.

1.4.4 For design pressure of steering gear components and piping, see Pt 5, Ch 19, 3.1 General 3.1.5.

1.5 Design temperature

1.5.1 The design temperature is to be taken as the maximum temperature of the internal fluid, but in no case is it to be less than 50°C.

1.5.2 In the case of pipes for superheated steam, the temperature is to be taken as the designed operating steam temperature for the pipeline, provided that the temperature at the superheater outlet is closely controlled. Where temperature fluctuations exceeding 15°C above the designed temperature are to be expected in normal service, the steam temperature to be used for determining the allowable stress is to be increased by the amount of this excess.

1.6 Classes of pipes

1.6.1 Pressure piping systems are divided into three classes for the purpose of assigning appropriate testing requirements, types of joints to be adopted, heat treatment and weld procedure.

1.6.2 Dependent on the service for which they are intended, Class II and III pipes are not to be used for design pressure or temperature conditions in excess of those shown in Table 12.1.1 Maximum pressure and temperature conditions for Class II and III piping systems. Where either the maximum design pressure or temperature exceeds that applicable to Class II pipes, Class I pipes are to be used. To illustrate this, see Figure 12.1.1 Classes of piping system.

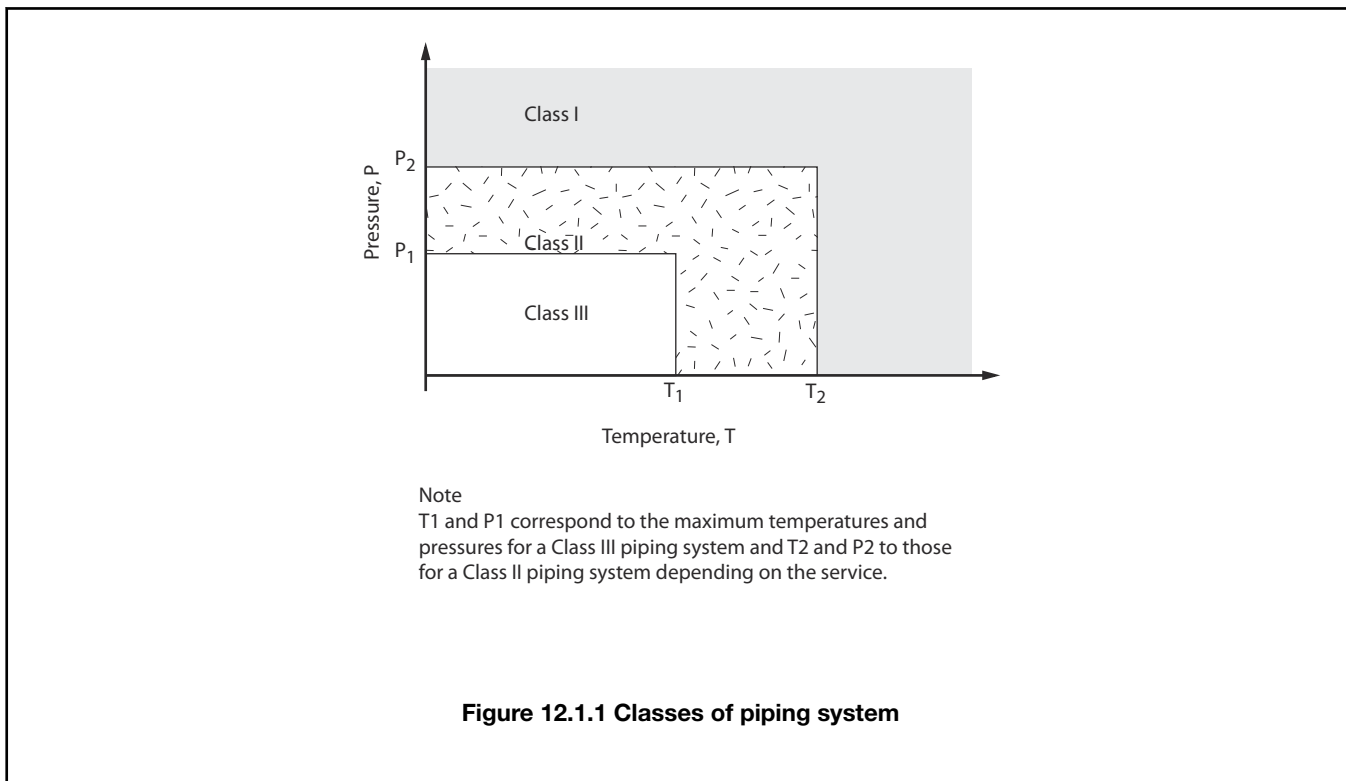

Table 12.1.1 Maximum pressure and temperature conditions for Class II and III piping systems

Piping system	Class II		Class III	
	p	T	p	T
	bar	°C	bar	°C
Steam	16,0	300	7,0	170
Thermal oil	16,0	300	7,0	150
Flammable Liquids, see Note 1	16,0	150	7,0	60
Other media	40,0	300	16,0	200
Cargo oil	40,0	300	16,0	200

Note 1. Flammable liquids include; fuel oil, lubricating oil and flammable hydraulic oil.
Note 2. For grey cast iron, see also Pt 5, Ch 12, 4.2 Grey cast iron 4.2.2.

1.6.3 In addition to the pressure piping systems in *Table 12.1.1 Maximum pressure and temperature conditions for Class II and III piping systems*, Class III pipes may be used for open ended piping, e.g. overflows, vents, boiler waste steam pipes, open ended drains, etc.

1.7 Materials

1.7.1 Materials for ferrous castings and forgings of Class I and Class II piping systems are to be produced at a works approved by Lloyd’s Register (hereinafter referred to as ‘LR’) and are in general to be tested in accordance with the *Rules for the Manufacture, Testing and Certification of Materials, July 2015* (hereinafter referred to as the Rules for Materials).

1.7.2 The Manufacturer’s materials certificate will be accepted in lieu of an LR materials certificate for Class III piping systems and for all other classes of piping and associated components where the maximum design conditions are less than the values

shown in *Table 12.1.2 Maximum conditions for pipes, valves and fittings for which manufacturer's materials test certificate is acceptable*. See *Ch 1, 3.1 General 3.1.3* of the Rules for Materials.

1.7.3 The manufacturer's certificate validated by LR for materials for ship-side valves and fittings and valves on the collision bulkhead equal to or less than 500 mm nominal diameter will be accepted in lieu of LR's materials certificate where the valves and fittings are in accordance with a recognised National Standard applicable to the intended application and are manufactured and tested in accordance with the appropriate requirements of the *Rules for the Manufacture, Testing and Certification of Materials, July 2015*. See *Ch 1, 3.1 General 3.1.3* of the Rules for Materials.

Table 12.1.2 Maximum conditions for pipes, valves and fittings for which manufacturer's materials test certificate is acceptable

Material	<i>DN</i> = nominal diameter, mm <i>p_w</i> = working pressure, bar
When the working temperature is less than 300°C: Carbon and low alloy steel, austenitic stainless steel and cast iron (spheroidal or nodular)	<i>DN</i> < 50 or <i>p_w</i> × <i>DN</i> < 2500
Copper alloy intended for a working temperature of less than 200°C	<i>DN</i> < 50 or <i>p_w</i> × <i>DN</i> < 1500

Section 2 Carbon and low alloy steels

2.1 Carbon and low alloy steel pipes, valves and fittings

2.1.1 Materials for Class I and Class II piping systems, also for ship-side valves and fittings and valves on the collision bulkhead, are to be manufactured and tested in accordance with the appropriate requirements of the Rules for Materials, see also *Pt 5, Ch 12, 1.7 Materials*.

2.1.2 Materials for Class III piping systems are to be manufactured and tested in accordance with the requirements of acceptable national specifications. Pipes having forge butt welded longitudinal seams are not to be used for fuel oil systems, for heating coils in oil tanks, or for pressures exceeding 4,0 bar (4,1 kgf/cm²). The manufacturer's certificate will be acceptable and is to be provided for each consignment of material. See *Ch 1, 3.1 General 3.1.3* of the Rules for Materials.

2.1.3 Steel pipes, valves and fittings may be used within the temperature limits indicated in *Table 12.2.1 Carbon and carbon-manganese steel pipes* and *Table 12.2.2 Alloy steel pipes*. Where rimming steel is used for pipes manufactured by electric resistance or induction welding processes, the design temperature is limited to 400°C, see *Ch 6, 3 Welded pressure pipes* of the Rules for Materials.

2.2 Wrought steel pipes and bends

2.2.1 The maximum permissible design stress, σ , is to be taken as the lowest of the following values:

$$\sigma = \frac{E_t}{1,6} \quad \sigma = \frac{R_{20}}{2,7} \quad \sigma = \frac{S_R}{1,6}$$

where

E_t = specified minimum lower yield or 0,2 per cent proof stress at the design temperature; in the case of stainless steel, the 1,0 per cent proof stress at design temperature is to be used

R_{20} = specified minimum tensile strength at ambient temperature

S_R = average stress to produce rupture in 100 000 hours at the design temperature

Values of the maximum permissible design stress, σ , obtained from the properties of the steels specified in *Ch 6 Steel Pipes and Tubes* of the Rules for Materials are shown in *Table 12.2.1 Carbon and carbon-manganese steel pipes* and *Table 12.2.2 Alloy steel pipes*. For intermediate values of specified minimum strengths and temperatures, values of the permissible design stress may be obtained by interpolation.

2.2.2 Where it is proposed to use, for high temperature service, alloy steels other than those detailed in *Table 12.2.2 Alloy steel pipes* particulars of the tube sizes, design conditions and appropriate national or proprietary material specifications are to be submitted for consideration.

Piping Design Requirements

Part 5, Chapter 12

Section 2

Table 12.2.1 Carbon and carbon-manganese steel pipes

Specified minimum tensile strength, N/mm ² (kgf/mm ²)	Maximum permissible stress, N/mm ² (kgf/cm ²)						
	Maximum design temperature, °C						
	50	100	150	200	250	300	
320 (33)	107 (1091)	105 (1070)	99 (1010)	92 (938)	78 (795)	62 (632)	
360 (37)	120 (1224)	117 (1193)	110 (1122)	103 (1050)	91 (928)	76 (775)	
410 (42)	136 (1387)	131 (1336)	124 (1264)	117 (1193)	106 (1081)	93 (948)	
460 (47)	151 (1540)	146 (1489)	139 (1417)	132 (1346)	122 (1244)	111 (1132)	
490 (50)	160 (1632)	156 (1591)	148 (1509)	141 (1438)	131 (1336)	121 (1234)	
	Maximum design temperature, °C						
	350	400	410	420	430	440	450
320 (33)	57 (581)	55 (561)	55 (561)	54 (551)	54 (551)	54 (551)	49 (500)
360 (37)	69 (704)	68 (693)	68 (693)	68 (693)	64 (653)	56 (571)	49 (500)
410 (42)	86 (877)	84 (857)	79 (806)	71 (724)	64 (653)	56 (571)	49 (500)
460 (47)	101 (1030)	99 (1010)	98 (999)	85 (876)	73 (744)	62 (632)	53 (540)
490 (50)	111 (1132)	109 (1111)	98 (999)	85 (867)	73 (744)	62 (632)	53 (540)

Table 12.2.2 Alloy steel pipes

Type of steel	Specified minimum tensile strength, N/mm ² (kgf/mm ²)	Maximum permissible stress, N/mm ² (kgf/cm ²)									
		Maximum design temperature, °C									
		50	100	200	300	350	400	440	450	460	470
1 Cr 1/2 Mo	440 (46)	159 (1621)	150 (1530)	137 (1397)	114 (1162)	106 (1081)	102 (1040)	101 (1030)	101 (1030)	100 (1020)	99 (1010)
2 1/4 Cr 1 Mo annealed	410 (42)	76 (775)	67 (683)	57 (581)	50 (510)	47 (479)	45 (459)	44 (449)	43 (438)	43 (438)	42 (428)
2 1/4 Cr 1 Mo normalised and tempered see Note 1	490 (50)	167 (1703)	163 (1662)	153 (1550)	144 (1468)	140 (1428)	136 (1387)	130 (1326)	128 (1305)	127 (1295)	116 (1183)

Piping Design Requirements

Part 5, Chapter 12

Section 2

2 1/4 Cr 1 Mo normalised and tempered see Note 2	490 (50)	167 (1703)	163 (1662)	153 (1560)	144 (1468)	140 (1428)	136 (1387)	130 (1326)	122 (1244)	114 (1162)	105 (1071)
1/2 Cr 1/2 Mo 1/4 V	460 (47)	166 (1693)	162 (1652)	147 (1499)	120 (1224)	115 (1173)	111 (1132)	106 (1081)	105 (1071)	103 (1050)	102 (1040)
		Maximum design temperature, °C									
		480	490	500	510	520	530	540	550	560	570
1 Cr 1/2 Mo	440 (46)	98 (999)	97 (989)	91 (928)	76 (775)	62 (632)	51 (520)	42 (428)	34 (347)	27 (275)	22 (224)
2 1/4 Cr 1 Mo annealed	410 (42)	42 (428)	42 (428)	41 (418)	41 (418)	41 (418)	40 (408)	40 (408)	40 (408)	37 (377)	32 (326)
2 1/4 Cr 1 Mo normalised and tempered see Note 1	490 (50)	106 (1081)	96 (979)	86 (877)	76 (775)	67 (683)	58 (591)	49 (500)	43 (438)	37 (377)	32 (326)
2 1/4 Cr 1 Mo normalised and tempered see Note 2	490 (50)	96 (979)	88 (897)	79 (806)	72 (734)	64 (653)	56 (571)	49 (500)	43 (438)	37 (377)	32 (326)
1/2 Cr 1/2 Mo 1/4 V	460 (47)	101 (1030)	99 (1010)	97 (989)	94 (959)	82 (836)	72 (734)	62 (632)	53 (540)	45 (459)	37 (377)
Note 1. Maximum permissible stress values applicable when the tempering temperature does not exceed 750 °C.											
Note 2. Maximum permissible stress values applicable when the tempering temperature exceeds 750 °C.											

2.2.3 The minimum thickness, *t*, of straight steel pipes is to be determined by the following formula:

$$t = \left(\frac{pD}{20 \sigma e + p} + c \right) \frac{100}{100 - a} \text{ mm}$$

$$\left(t = \left(\frac{pD}{2 \sigma e + p} + c \right) \frac{100}{100 - a} \text{ mm} \right)$$

where

= *p*, *D*, *e* and *a* are as defined in Pt 5, Ch 12, 1.3 Design symbols 1.3.1

c = is obtained from Table 12.2.3 Values of *c* for steel pipes

σ = is defined in Pt 5, Ch 12, 2.2 Wrought steel pipes and bends 2.2.1 and obtained from Table 12.2.1 Carbon and carbon-manganese steel pipes or Table 12.2.2 Alloy steel pipes

For pipes passing through tanks, an additional corrosion allowance is to be added to take account of external corrosion; the addition will depend on the external medium and the value is to be in accordance with Table 12.2.3 Values of *c* for steel pipes. Where the pipes are efficiently protected, the corrosion allowance may be reduced by not more than 50 per cent.

Table 12.2.3 Values of *c* for steel pipes

Piping service	<i>c</i> mm
Superheated steam systems	0,3
Saturated steam systems	0,8
Steam coil systems in cargo tanks	2,0
Feed water for boilers in open circuit systems	1,5
Feed water for boilers in closed circuit systems	0,5

Blow down (for boilers) systems	1,5
Compressed air systems	1,0
Hydraulic oil systems	0,3
Lubricating oil systems	0,3
Fuel oil systems	1,0
Cargo oil systems	2,0
Refrigerating plants	0,3
Fresh water systems	0,8
Sea-water systems in general	3,0

2.2.4 The minimum thickness, t_b , of a straight steel pipe to be used for a pipe bend is to be determined by the following formula, except where it can be demonstrated that the use of a thickness less than t_b would not reduce the thickness below t at any point after bending:

$$t_b = \left[\left(\frac{pD}{20 \sigma e + p} \right) \left(1 + \frac{D}{2,5R} \right) + c \right] \frac{100}{100 - a} \text{ mm}$$

$$(t_b = \left[\left(\frac{pD}{2 \sigma e + p} \right) \left(1 + \frac{D}{2,5R} \right) + c \right] \frac{100}{100 - a} \text{ mm})$$

= where p , D , R , e and a are as defined in Pt 5, Ch 12, 1.3 Design symbols 1.3.1

= σ and c are as defined in Pt 5, Ch 12, 2.2 Wrought steel pipes and bends 2.2.3. In general, R is to be not less than $3D$.

2.2.5 Where the minimum thickness calculated by Pt 5, Ch 12, 2.2 Wrought steel pipes and bends 2.2.3 or Pt 5, Ch 12, 2.2 Wrought steel pipes and bends 2.2.4 is less than that shown in Table 12.2.4 Minimum thickness for steel pipes, the minimum nominal thickness for the appropriate standard pipe size shown in the Table is to be used. No allowance is required for negative tolerance, corrosion or reduction in thickness due to bending on this nominal thickness. For larger diameters, the minimum thickness will be considered. For threaded pipes, where permitted, the minimum thickness is to be measured at the bottom of the thread.

2.2.6 For sounding pipes, except those for cargo tanks with cargo having a flash point of less than 60°C, the minimum thickness is intended to apply to the part outside the tank.

2.2.7 For air, bilge, ballast, fuel, overflow, sounding and venting pipes as listed in Table 12.2.4 Minimum thickness for steel pipes, where the pipes are efficiently protected against corrosion, the thickness may be reduced by not more than 1 mm.

Table 12.2.4 Minimum thickness for steel pipes

External diameter, D , in mm	Pipes in general, in mm	Venting, overflow and sounding pipes for structural tanks, in mm	Bilge, ballast and general sea-water pipes, in mm	Bilge, air, overflow and sounding pipes through ballast and fuel tanks, ballast lines through fuel tanks and fuel lines through ballast tanks, in mm	Air, overflow and sounding pipes for fuel oil tanks passing through cargo holds of bulk carriers, in mm
10,2-12	1,6	-	-	-	-
13,5-19	1,8	-	-	-	-
20	2,0	-	-	-	-
21,3-25	2,0	-	3,2	-	-
26,9-33,7	2,0	-	3,2	-	-

38-44,5	2,0	4,5	3,6	6,3	-
48,3	2,3	4,5	3,6	6,3	-
51-63,5	2,3	4,5	4,0	6,3	6,3
70	2,6	4,5	4,0	6,3	6,3
76,1-82,5	2,6	4,5	4,5	6,3	7,6
88,9-108	2,9	4,5	4,5	7,1	8,0
114,3-127	3,2	4,5	4,5	8,0	8,8
133-139,7	3,6	4,5	4,5	8,0	8,8
152,4-168,3	4,0	4,5	4,5	8,8	8,8
177,8	4,5	5,0	5,0	8,8	8,8
193,7	4,5	5,4	5,4	8,8	8,8
219,1	4,5	5,9	5,9	8,8	12,5
244,5-273	5,0	6,3	6,3	8,8	12,5
98,5-368	5,6	6,3	6,3	8,8	12,5
2406,4-457,2	6,3	6,3	6,3	8,8	12,5

Note The pipe diameters and wall thicknesses given in the Table are based on common International Standards. Diameter and thickness according to other National or International Standards will be considered.

2.2.8 The internal diameter for bilge, venting and overflow pipes listed in *Table 12.2.4 Minimum thickness for steel pipes* is to be not less than 50 mm. The internal diameter for sounding pipes is to be not less than 32 mm.

2.3 Pipe joints - General

2.3.1 Joints in pressure pipelines may be made by:

- Screwed-on or welded-on bolted flanges, see *Pt 5, Ch 12, 2.5 Screwed-on flanges* and *Pt 5, Ch 12, 2.6 Welded-on flanges, butt welded joints and fabricated branch pieces*.
- Butt welds between pipes or between pipes and valve chests or other fittings, see *Pt 5, Ch 12, 2.6 Welded-on flanges, butt welded joints and fabricated branch pieces*.
- Socket weld joints, see *Pt 5, Ch 12, 2.8 Socket weld joints*.
- Welded sleeve joints, see *Pt 5, Ch 12, 2.9 Welded sleeve joints*.
- Threaded sleeve joints, see *Pt 5, Ch 12, 2.10 Threaded sleeve joints*
- Special types of approved joints that have been shown to be suitable for the design conditions. Details are to be submitted for consideration.

2.3.2 The dimensions and materials of flanges, gaskets and bolting, and the pressure – temperature rating of bolted flanges in pressure pipelines, are to be in accordance with National or other established Standards.

2.3.3 With the welded pressure piping systems referred to in *Pt 5, Ch 12, 2.3 Pipe joints - General 2.3.1* it is desirable that a few flanged joints be provided at suitable positions to facilitate installation, cold 'pull up' and inspection at Periodical Surveys.

2.3.4 Piping with joints is to be adequately adjusted, aligned and supported. Supports or hangers are not to be used to force alignment of piping at the point of connection.

2.3.5 Pipes passing through, or connected to, watertight decks are to be continuous or provided with an approved bolted or welded connection to the deck or bulkhead.

2.3.6 Consideration will be given to accepting joints in accordance with a recognised National Standard which is applicable to the intended service and media conveyed.

2.4 Steel pipe flanges

2.4.1 Flanges may be cut from plates or may be forged or cast. The material is to be suitable for the design temperature. Flanges may be attached to the pipes by screwing and expanding or by welding. Alternative methods of flange attachment may be accepted provided details are submitted for consideration.

2.4.2 Flange attachments to pipes and pressure – temperature ratings in accordance with National or other approved Standards will be accepted.

2.5 Screwed-on flanges

2.5.1 Where flanges are secured by screwing, as indicated in *Figure 12.2.1 Screwed-on flange*, the pipe and flange are to be screwed with a vanishing thread and the diameter of the screwed portion of the pipe over the thread is not to be appreciably less than the outside diameter of the unscrewed pipe. After the flange has been screwed hard home the pipe is to be expanded into the flange.

2.5.2 The vanishing thread on a pipe is to be not less than three pitches in length, and the diameter at the root of the thread is to increase uniformly from the standard root diameter to the diameter at the top of the thread. This may be produced by suitably grinding the dies, and the flange should be tapered out to the same formation.

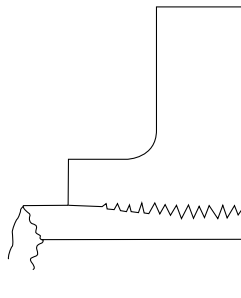

Figure 12.2.1 Screwed-on flange

2.5.3 Such screwed and expanded flanges may be used for steam for a maximum design pressure of 30,0 bar (30,5 kgf/cm²) and a maximum design temperature of 370°C and for feed for a maximum design pressure of 50 bar (51 kgf/cm²).

2.6 Welded-on flanges, butt welded joints and fabricated branch pieces

2.6.1 The types of welded-on flanges are to be suitable for the pressure, temperature and service for which the pipes are intended.

2.6.2 Typical examples of welded-on flange attachments are shown in *Figure 12.2.2 Typical welded-on flanges*, and limiting design conditions for flange types (a) to (f) are shown in *Table 12.2.5 Limiting design conditions for flange types*.

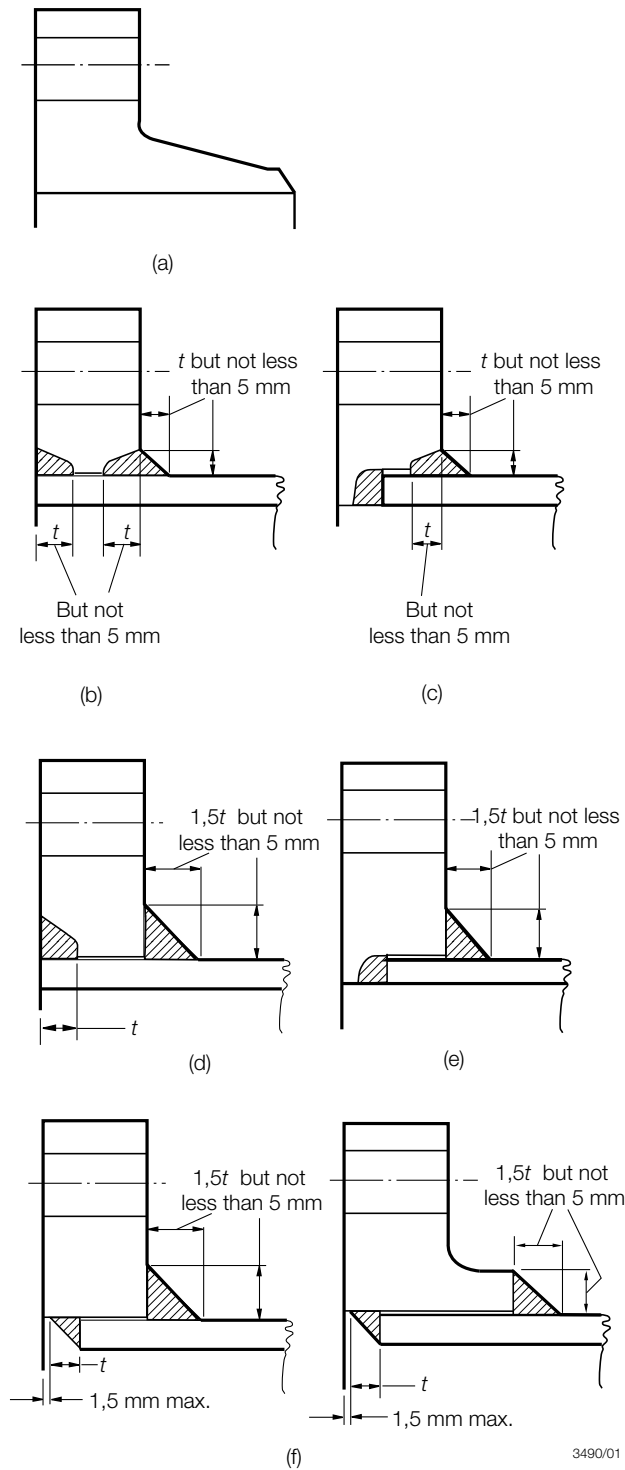

Figure 12.2.2 Typical welded-on flanges

Table 12.2.5 Limiting design conditions for flange types

Flange type	Maximum pressure	Maximum temperature, in °C	Maximum pipe o.d., in mm	Minimum pipe bore, in mm
-------------	------------------	-------------------------------	-----------------------------	-----------------------------

(a)	Pressure-temperature ratings to be in accordance with a Recognised Standard	No restriction	No restriction	No restriction
(b)	Pressure-temperature ratings to be in accordance with a Recognised Standard	No restriction	168,3 for alloy steels*	No restriction
(c)	Pressure-temperature ratings to be in accordance with a Recognised Standard	No restriction	168,3 for alloy steels*	75
(d)	Pressure-temperature ratings to be in accordance with a Recognised Standard	425	No restriction	No restriction
(e)	Pressure-temperature ratings to be in accordance with a Recognised Standard	425	No restriction	75
(f)	Pressure-temperature ratings to be in accordance with a Recognised Standard	425	No restriction	No restriction

* No restriction for carbon steels

2.6.3 Butt welded joints are generally to be of the full penetration type and are to meet the requirements of *Pt 5, Ch 13 Ship Piping Systems* of the Rules for Materials.

2.6.4 Welded-on flanges are not to be a tight fit on the pipes. The maximum clearance between the bore of the flange and the outside diameter of the pipe is to be 3 mm at any point, and the sum of the clearances diametrically opposite is not to exceed 5 mm.

2.6.5 Where butt welds are employed in the attachment of flange type (a), in pipe-to-pipe joints or in the construction of branch pieces, the adjacent pieces are to be matched at the bores. This may be effected by drifting, roller expanding or machining, provided that the pipe wall is not reduced below the designed thickness. If the parts to be joined differ in wall thickness, the thicker wall is to be gradually tapered to the thickness of the thinner at the butt joint. The welding necks of valve chests are to be sufficiently long to ensure that the valves are not distorted as the result of welding and subsequent heat treatment of the joints.

2.6.6 Where backing rings are used with flange type (a) they are to fit closely to the bore of the pipe and should be removed after welding. The rings are to be made of the same material as the pipes or of mild steel having a sulphur content not greater than 0,05 per cent.

2.6.7 Branches may be attached to pressure pipes by means of welding provided that the pipe is reinforced at the branch by a compensating plate or collar or other approved means, or, alternatively, that the thickness of pipe and branch is increased to maintain the strength of the pipe. These requirements also apply to fabricated branch pieces.

2.6.8 Welding may be carried out by means of the shielded metal arc, inert gas metal arc, oxy-acetylene or other approved process, but in general oxy-acetylene welding is suitable only for flange type (a) and is not to be applied to pipes exceeding 100 mm diameter or 9,5 mm thick. The welding is to be carried out in accordance with the appropriate paragraphs of *Pt 5, Ch 17 Requirements for Fusion Welding of Pressure Vessels and Piping*.

2.7 Loose flanges

2.7.1 Loose flange designs as shown in *Figure 12.2.3 Loose flange arrangements* may be used provided they are in accordance with a recognised National or International Standard.

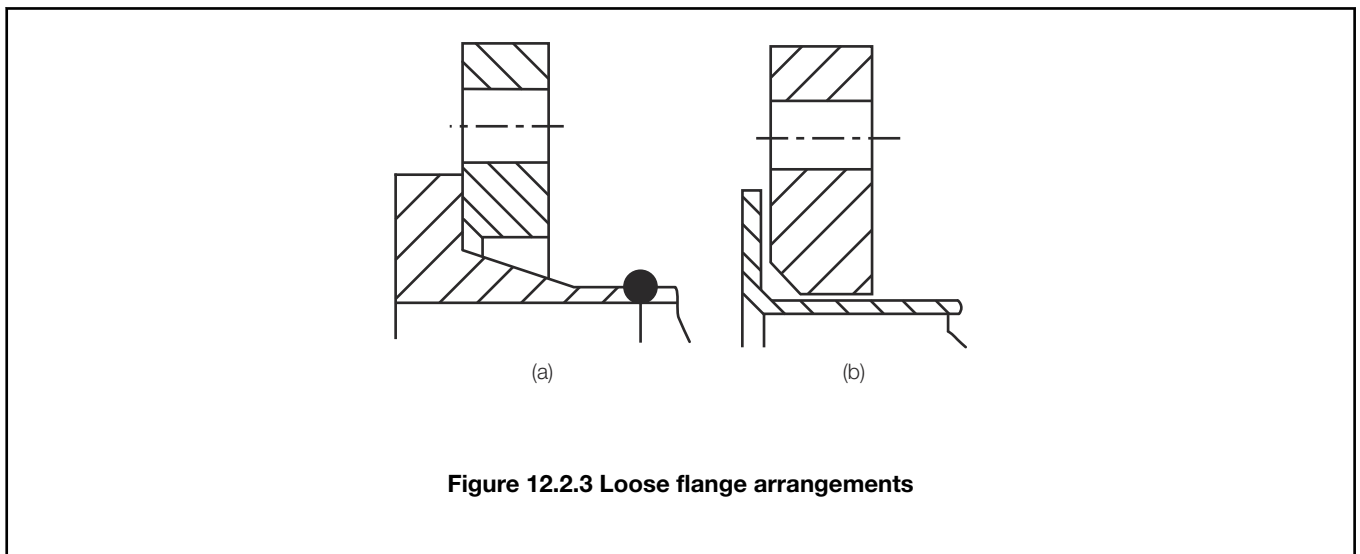

2.7.2 Loose flange designs where the pipe end is flared as shown in *Figure 12.2.3 Loose flange arrangements(b)* are only to be used for water pipes and on open ended lines.

2.8 Socket weld joints

2.8.1 Socket weld joints may be used in Class III systems with carbon steel pipes of any outside diameter. Socket weld fittings are to be of forged steel and the material is to be compatible with the associated piping. In particular cases, socket welded joints may be permitted for piping systems of Class I and II having outside diameter not exceeding 88,9 mm. Such joints are not to be used where fatigue, severe erosion or crevice corrosion is expected to occur or where toxic or asphyxiating media are conveyed, other than for carbon dioxide fire-extinguishing distribution piping, see also *Pt 5, Ch 10, 14.4 Welded-on flanges, butt welded joints and fabricated branch pieces 14.4.9*.

2.8.2 The thickness of the socket weld fittings is to meet the requirements of *Pt 5, Ch 12, 2.2 Wrought steel pipes and bends 2.2.3* but is to be not less than 1,25 times the nominal thickness of the pipe or tube. The diametrical clearance between the outside diameter of the pipe and the bore of the fitting is not to exceed 0,8 mm, and a gap of approximately 1,5 mm is to be provided between the end of the pipe and the bottom of the socket. See also *Ch 13, 5.2 Manufacture and workmanship 5.2.9* of the Rules for Materials.

2.8.3 The leg lengths of the fillet weld connecting the pipe to the socket weld fitting are to be such that the throat dimension of the weld is not less than the nominal thickness of the pipe or tube.

2.8.4 Socket weld joints may be used in carbon dioxide fire-extinguishing system distribution piping only as permitted by *Pt 5, Ch 12, 2.14 Carbon dioxide (CO₂) fire-extinguishing system piping*.

2.9 Welded sleeve joints

2.9.1 Welded sleeve joints may be used in Class III systems with carbon steel pipes of any outside diameter. In particular cases, welded sleeve joints may be permitted for piping systems of Class I and II having outside diameter not exceeding 88,9 mm. Such joints are not to be used where fatigue, severe erosion or crevice corrosion is expected to occur or where toxic or asphyxiating media, other than for carbon dioxide fire-extinguishing distribution piping, are conveyed.

2.9.2 Welded sleeve joints are not to be used in the following locations:

- Bilge pipes in way of deep tanks.
- Cargo oil piping outside of the cargo area for bow or stern loading/discharge.
- Air and sounding pipes passing through cargo tanks.

2.9.3 Welded sleeve joints may be used in piping systems for the storage, distribution and utilisation of fuel oil, lubricating or other flammable oil systems in machinery spaces provided they are located in readily visible and accessible positions. See also *Pt 5, Ch 14, 2.9 Precautions against fire 2.9.2*.

2.9.4 Welded sleeve joints may be used in carbon dioxide fire-extinguishing system distribution piping only as permitted by *Pt 5, Ch 12, 2.14 Carbon dioxide (CO₂) fire-extinguishing system piping*.

2.9.5 Welded sleeve joints are not to be used at deck/bulkhead penetrations that require continuous pipe lengths.

2.9.6 The thickness of the sleeve is to satisfy the requirements of *Pt 5, Ch 12, 2.2 Wrought steel pipes and bends 2.2.3 and Table 12.2.4 Minimum thickness for steel pipes* but is to be not less than 1,42 times the nominal thickness of the pipe in order to satisfy the throat thickness requirement in *Pt 5, Ch 12, 2.9 Welded sleeve joints 2.9.7*. The radial clearance between the outside diameter of the pipe and the internal diameter of the sleeve is not to exceed 1 mm for pipes up to a nominal diameter of 50 mm, 2 mm on diameters up to 200 mm nominal size and 3 mm for larger size pipes. The pipe ends are to be separated by a clearance of approximately 2 mm at the centre of the sleeve. Alternatively, consideration will be given to sleeve thickness in accordance with a relevant National Standard.

2.9.7 The sleeve material is to be compatible with the associated piping and the leg lengths of the fillet weld connecting the pipe to the sleeve are to be such that the throat dimension of the weld is not less than the nominal thickness of the pipe or tube.

2.9.8 The minimum length of the sleeve is to conform to the following formula:

$$L_{si} = 0,14D + 36$$

where

= L_{si} is the length of the sleeve

= D is defined in *Pt 5, Ch 12, 1.3 Design symbols 1.3.1*.

2.10 Threaded sleeve joints

2.10.1 Threaded sleeve joints, in accordance with National or other established Standards, may be used with carbon steel pipes within the limits given in *Table 12.2.6 Limiting design conditions for threaded sleeve joints*. Such joints are not to be used where fatigue, severe erosion or crevice corrosion is expected to occur or where flammable or toxic media is conveyed.

Table 12.2.6 Limiting design conditions for threaded sleeve joints

Thread type	Outside pipe diameter, in mm		
	Class I	Class II	Class III
Tapered thread	<33,7	<60,3	<60,3
Parallel thread	-	-	<60,3

2.11 Screwed fittings

2.11.1 Screwed fittings, including compression fittings, of an approved type may be used in piping systems for pipes not exceeding 51 mm outside diameter. Where the fittings are not in accordance with an acceptable standard then LR may require the fittings to be subjected to special tests to demonstrate their suitability for the intended service and working conditions.

2.12 Other mechanical couplings

2.12.1 Pipe unions, compression couplings, and or slip-on joints, as shown in *Pt 5, Ch 12, 2.12 Other mechanical couplings 2.12.1 and Pt 5, Ch 12, 2.12 Other mechanical couplings 2.12.1*, may be used if Type Approved for the service conditions and the intended application. The Type Approval is to be based on the results of testing of the actual joints. The acceptable use for each service is indicated in *Table 12.2.7 Application of mechanical joints* and dependence upon the Class of piping, with limiting pipe dimensions, is indicated in *Table 12.2.8 Application of mechanical joints depending on class of piping*.

Pipe Unions	
Welded and Brazed Types	
Compression Couplings	
Swage Type	
Press Type	
Bite Type	
Flared Type	

Figure 12.2.4 Examples of mechanical joints (Part 1)

Slip-on Joints	
Grip Type	
Machine Grooved Type	
Slip Type	

Figure 12.2.5 Examples of mechanical joints (Part 2)

Table 12.2.7 Application of mechanical joints

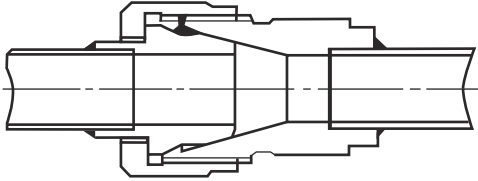
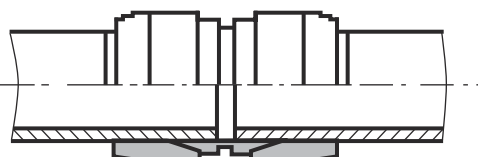
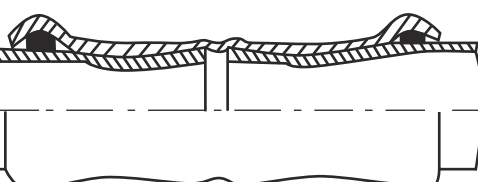
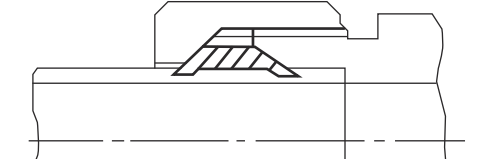
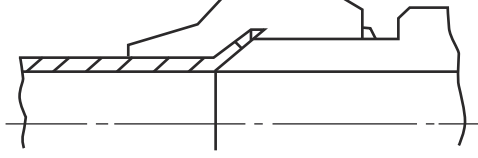
Systems	Kind of connections		
	Pipe unions	Compression couplings (6)	Slip-on joints
Flammable fluids (Flash point <60°)			
Cargo oil lines	+	+	+5
Crude oil washing lines	+	+	+5
Vent lines	+	+	+3
Inert gas			
Water seal effluent lines	+	+	+
Scrubber effluent lines	+	+	+
Main lines	+	+	+2,5
Distribution lines	+	+	+5
Flammable fluids (Flash point > 60°)			
Cargo oil lines	+	+	+5
Fuel oil lines	+	+	+2,3
Lubricating oil lines	+	+	+2,3
Hydraulic oil	+	+	+2,3
Thermal oil	+	+	+2,3
Sea-water			
Bilge lines	+	+	+1
Fire main and water spray	+	+	+3
Foam system	+	+	+3
Sprinkler system	+	+	+3
Ballast system	+	+	+1
Cooling water system	+	+	+1
Tank cleaning services	+	+	+
Non-essential systems	+	+	+
Fresh water			
Cooling water system	+	+	+1
Condensate return	+	+	+1
Non-essential system	+	+	+
Sanitary/Drains/Scuppers			
Deck drains (internal)	+	+	+4
Sanitary drains	+	+	+
Scuppers and discharge (overboard)	+	+	-
Sounding/vent			
Water tanks/Dry spaces	+	+	+

Oil tanks (f.p.> 60°C)	+	+	+2,3
Miscellaneous			
Starting/Control air (1)	+	+	-
Service air (non-essential)	+	+	+
Brine	+	+	+
CO ₂ system	+	+	-
Steam	+	+	+7
KEY			
+ Application is allowed			
- Application is not allowed			
Note 1. Inside machinery spaces of category A - only approved fire resistant types.			
Note 2. Not inside machinery spaces of category A or accommodation spaces. May be accepted in other machinery spaces provided the joints are located in easily visible and accessible positions.			
Note 3. Approved fire resistant types. Fire resistant type is a type of connection which, when installed in the system and in the event of failure caused by fire, the failure would not result in fire spread, flooding or the loss of an essential service.			
Note 4. Above freeboard deck only.			
Note 5. In pump rooms and open decks - only approved fire resistant types.			
Note 6. If compression couplings include any components which are sensitive to heat, they are to be of approved fire resistant type as required for slip-on joints.			
Note 7. See Pt 5, Ch 12, 2.12 Other mechanical couplings 2.12.11			

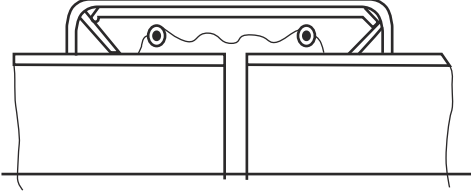
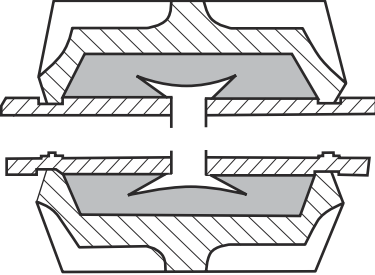
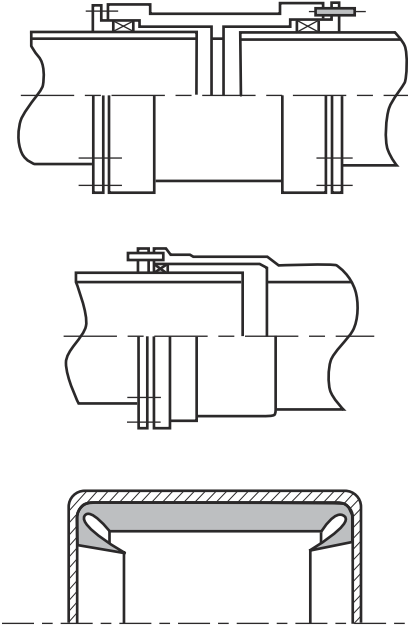
Table 12.2.8 Application of mechanical joints depending on class of piping

Types of joints	Classes of piping systems		
	Class I	Class II	Class III
Pipe unions			
Welded and brazed type	+(OD ≤ 60,3 mm)	+(OD ≤ 60,3 mm)	+
Compression couplings			
Swage type	+	+	+
Bite type	+(OD ≤ 60,3 mm)	+(OD ≤ 60,3 mm)	+
Flared type	+(OD ≤ 60,3 mm)	+(OD ≤ 60,3 mm)	+
Press type	-	-	+
Slip-on joints			
Machine grooved type	+	+	+
Grip type	-	+	+
Slip type	-	+	+
KEY			
+ Application is allowed			
- Application is not allowed			

2.12.2 Where the application of mechanical joints results in a reduction in pipe wall thickness due to the use of bite type rings or other structural elements, this is to be taken into account in determining the minimum wall thickness of the pipe to withstand the design pressure.

2.12.3 Construction of mechanical joints is to prevent the possibility of tightness failure affected by pressure pulsation, piping vibration, temperature variation and other similar adverse effects occurring during operation on board.

2.12.4 Materials of mechanical joints are to be compatible with the piping material and internal and external media.

2.12.5 Mechanical joints for pressure pipes are to be tested to a burst pressure of 4 times the design pressure. For design pressures above 200 bar the required burst pressure will be specially considered.

2.12.6 In general, mechanical joints are to be of fire resistant type where required by *Table 12.2.7 Application of mechanical joints*.

2.12.7 Mechanical joints, which in the event of damage could cause fire or flooding, are not to be used in piping sections directly connected to the sea openings or tanks containing flammable fluids.

2.12.8 The mechanical joints are to be designed to withstand internal and external pressure as applicable and where used in suction lines are to be capable of operating under vacuum.

2.12.9 Generally, slip-on joints are not to be used in pipelines in cargo holds, tanks, and other spaces which are not easily accessible. Application of these joints inside tanks may only be accepted where the medium conveyed is the same as that in the tanks.

2.12.10 Unrestrained slip-on joints are only to be used in cases where compensation of lateral pipe deformation is necessary. Usage of these joints as the main means of pipe connection is not permitted.

2.12.11 Restrained slip-on joints are permitted in steam pipes with a design pressure of 10 bar or less on the weather decks of oil and chemical tankers to accommodate axial pipe movement, see *Pt 5, Ch 13, 2.7 Provision for expansion*.

2.12.12 Mechanical joints are to be tested in accordance with the test requirements of LR's Type Approval Test Specification Number 2, as relevant to the service conditions and the intended application. The programme of testing is to be agreed with LR.

2.13 Non-destructive testing

2.13.1 For details of non-destructive tests on piping systems, other than hydraulic tests, see *Pt 5, Ch 13 Ship Piping Systems* of the Rules for Materials.

2.14 Carbon dioxide (CO₂) fire-extinguishing system piping

2.14.1 The piping for carbon dioxide fire-extinguishing systems is to comply with the requirements of *Chapter 5 - Fixed Gas Fire-Extinguishing Systems* of the FSS Code, as applicable. For purposes of Classification, any use of the word 'Administration' in the Regulation is to be taken to mean LR.

2.14.2 Materials for the distribution manifolds between the carbon dioxide storage bottles and the discharge valves to each section and associated pipes, valves and fittings of high pressure systems are to be manufactured and tested in accordance with the requirements for Class I piping systems. Pipes are to meet the minimum wall thickness requirements of *Table 12.2.4 Minimum thickness for steel pipes* and the manifold system is to be hydraulically tested to a pressure of 190 bar. A high pressure system is defined as a system where the carbon dioxide is stored at ambient temperature.

Materials for the distribution manifolds between the carbon dioxide storage vessel(s) and the discharge valves to each section and associated pipes, valves and fittings of low pressure systems are to be manufactured and tested in accordance with the requirements for Class II piping systems and the manifold system is to be hydraulically tested to a pressure of 33 bar. A low pressure system is defined as a system where the carbon dioxide is stored at a working pressure in the range of 1,8 N/mm² to 2,2 N/mm².

2.14.3 Piping downstream of the distribution valve(s) for high pressure systems is to be manufactured and tested in accordance with the requirements for Class II piping and is to meet the minimum wall thickness requirements of *Table 12.2.4 Minimum thickness for steel pipes*. After installation the distribution system is to be leak tested at a pressure of 6 bar.

Piping downstream of the distribution valve(s) for low pressure systems is to be manufactured and tested in accordance with the requirements for Class III piping. After installation the distribution system is to be leak tested at a pressure of 6 bar. Class III piping may be used for open ended distribution piping downstream of the distribution valve(s) of high pressure systems where agreed by LR and where meeting the minimum wall thickness requirements of *Table 12.2.4 Minimum thickness for steel pipes* and where a

minimum of ten per cent of the piping is hydraulically tested at a pressure of 125 bar. This testing is to be carried out before installation.

2.14.4 Any part of the carbon dioxide fire-extinguishing system piping is to be of galvanised steel or of corrosion resistant steel. Where full penetration butt welding is used, the pipe is to be protected against corrosion in the area of the weld seam after welding. The process for protecting the pipe internally against corrosion is to be of an approved type. All pipes are to be arranged to be self-draining. Where pipes are to be led into refrigerated spaces, this is subject to special consideration. The ends of distribution pipes downstream of the distribution valve(s) are to extend at least 50 mm beyond the last nozzle and are to be fitted with a dirt trap consisting of an open ended tee with a capped nipple.

2.14.5 If it is necessary for carbon dioxide pipes to pass through accommodation spaces, the pipe is to be seamless and is to meet the requirements for Class II pipes. Joints are to be made only by welding and the pipes are to be hydraulically tested after installation at a pressure of 50 bar.

2.14.6 The following means are permitted for making joints on carbon dioxide fire-extinguishing system piping ;

- (a) Full penetration butt welding, where the pipe is galvanised, see *Pt 5, Ch 12, 2.14 Carbon dioxide (CO₂) fire-extinguishing system piping 2.14.4*.
- (b) Couplings as permitted by *Table 12.2.7 Application of mechanical joints*.
- (c) Cone connections.
- (d) Tapered screw joints , where allowed by *Pt 5, Ch 12, 2.14 Carbon dioxide (CO₂) fire-extinguishing system piping 2.14.10* and where meeting the requirements of *Pt 5, Ch 12, 2.14 Carbon dioxide (CO₂) fire-extinguishing system piping 2.14.10*.
- (e) Flanged joints.
- (f) Socket weld joints to acceptable National Standards and where allowed by *Pt 5, Ch 12, 2.14 Carbon dioxide (CO₂) fire-extinguishing system piping 2.14.7* and where meeting the requirements of *Pt 5, Ch 12, 2.14 Carbon dioxide (CO₂) fire-extinguishing system piping 2.14.9*.
- (g) Welded sleeve joints may be used where allowed by *Pt 5, Ch 12, 2.14 Carbon dioxide (CO₂) fire-extinguishing system piping 2.14.8* and where meeting the requirements of *Pt 5, Ch 12, 2.14 Carbon dioxide (CO₂) fire-extinguishing system piping 2.14.9*.

2.14.7 Socket weld joints of an approved type may be used downstream of the distribution valve(s), provided that the requirements for materials and limitations on outside diameter applicable for Class II piping are applied.

2.14.8 Welded sleeve joints of an approved type may be used within the protected space, provided that the requirements for materials and limitations on outside diameter applicable for Class II piping are applied.

2.14.9 Where socket weld joints or welded sleeve joints are utilised, the pipes in way of the welded joints are to be adequately supported and the joints are to be located where they are visible. Where welding is to be carried out *in situ*, the piping is to be kept clear of adjacent structures to allow sufficient access for preheating and welding, which is to be carried out in accordance with approved procedures.

2.14.10 Threaded joints are only allowed inside the protected spaces and in carbon dioxide bottles storage rooms. They should have no exposed screw threads and any sealing medium should be selected as to ensure no protrusions or debris might be produced in the pipe.

■ Section 3 Copper and copper alloys

3.1 Copper and copper alloy pipes, valves and fittings

3.1.1 Materials for Class I and Class II piping systems, also for ship-side valves and fittings and valves on the collision bulkhead, are to be manufactured and tested in accordance with the requirements of *Ch 9 Copper Alloys* of the Rules for Materials, see also *Pt 5, Ch 12, 1.7 Materials*.

3.1.2 Materials for Class III piping systems are to be manufactured and tested in accordance with the requirements of acceptable National Specifications. The manufacturer's certificate will be acceptable and is to be provided for each consignment of material. See *Ch 1, 3.1 General 3.1.3* of the Rules for Materials.

3.1.3 Pipes are to be seamless, and branches are to be provided by cast or stamped fittings, pipe pressings or other approved fabrications.

3.1.4 Brazing and welding materials are to be suitable for the operating temperature and for the medium being carried. All brazing and welding are to be carried out to the satisfaction of the Surveyors.

3.1.5 In general, the maximum permissible service temperature of copper and copper alloy pipes, valves and fittings is not to exceed 200°C for copper and aluminium brass, and 300°C for copper-nickel. Cast bronze valves and fittings complying with the requirements of *Ch 9 Copper Alloys* of the Rules for Materials may be accepted up to 260°C.

3.1.6 The minimum thickness, t , of straight copper and copper alloy pipes is to be determined by the following formula:

$$t = \left(\frac{pD}{20\sigma + p} + c \right) \frac{100}{100 - a} \text{ mm}$$

$$\left(t = \left(\frac{pD}{2\sigma + p} + c \right) \frac{100}{100 - a} \text{ mm} \right)$$

where

p, D and a = are as defined in *Pt 5, Ch 12, 1.3 Design symbols 1.3.1*

c = corrosion allowance

= 0,8 mm for copper, aluminium brass, and copper-nickel alloys where the nickel content is less than 10 per cent

= 0,5 mm for copper-nickel alloys where the nickel content is 10 per cent or greater

= 0 where the media are non-corrosive relative to the pipe material

σ = maximum permissible design stress, in N/mm² (kgf/cm²), from *Table 12.3.1 Copper and copper alloy pipes*. Intermediate values of stresses may be obtained by linear interpolation.

3.1.7 The minimum thickness, t_b , of a straight seamless copper or copper alloy pipe to be used for a pipe bend is to be determined by the formula below, except where it can be demonstrated that the use of a thickness less than t_b would not reduce the thickness below t at any point after bending:

$$t_b = \left[\left(\frac{pD}{20\sigma + p} \right) \left(1 + \frac{D}{2,5R} \right) + c \right] \frac{100}{100 - a} \text{ mm}$$

$$\left(t_b = \left[\left(\frac{pD}{2\sigma + p} \right) \left(1 + \frac{D}{2,5R} \right) + c \right] \frac{100}{100 - a} \text{ mm} \right)$$

where

p, D, R and a = are as defined in *Pt 5, Ch 12, 1.3 Design symbols 1.3.1*

= σ and c are as defined in *Pt 5, Ch 12, 3.1 Copper and copper alloy pipes, valves and fittings 3.1.6*. In general, R is to be not less than $3D$.

Table 12.3.1 Copper and copper alloy pipes

Pipe material	Condition of supply	Specified minimum tensile strength, N/mm ² (kgf/mm ²)	Permissible stress, N/mm ² (kgf/cm ²)										
			Maximum design temperature, °C										
			50	75	100	125	150	175	200	225	250	275	300
Copper	Annealed	220 (22)	41,2 (420)	41,2 (420)	40,2 (410)	40,2 (410)	34,3 (350)	27,5 (280)	18,6 (190)	—	—	—	—

Aluminium brass	Annealed	320 (33)	78,5 (800)	78,5 (800)	78,5 (800)	78,5 (800)	78,5 (800)	51,0 (520)	24,5 (250)	—	—	—	—
90/10 Copper-nickel-iron	Annealed	270 (28)	68,6 (700)	68,6 (700)	67,7 (690)	65,7 (670)	63,7 (650)	61,8 (630)	58,8 (600)	55,9 (570)	52,0 (530)	48,1 (490)	44,1 (450)
70/30 Copper-nickel	Annealed	360 (37)	81,4 (830)	79,4 (810)	77,5 (790)	75,5 (770)	73,5 (750)	71,6 (730)	69,6 (710)	67,7 (690)	65,7 (670)	63,7 (650)	61,8 (630)

3.1.8 Where the minimum thickness calculated by Pt 5, Ch 12, 3.1 Copper and copper alloy pipes, valves and fittings 3.1.6 or Pt 5, Ch 12, 3.1 Copper and copper alloy pipes, valves and fittings 3.1.7 is less than shown in Table 12.3.2 Minimum thickness for copper and copper alloy pipes, the minimum nominal thickness for the appropriate standard pipe size shown in the Table is to be used. No allowance is required for negative tolerance or reduction in thickness due to bending on this nominal thickness. For threaded pipes, where permitted, the minimum thickness is to be measured at the bottom of the thread.

Table 12.3.2 Minimum thickness for copper and copper alloy pipes

Standard pipe sizes (outside diameter), in mm			Minimum overriding nominal thickness, in mm	
			Copper	Copper alloy
8	to	10	1,0	0,8
12	to	20	1,2	1,0
25	to	44,5	1,5	1,2
50	to	76,1	2,0	1,5
88,9	to	108	2,5	2,0
133	to	159	3,0	2,5
193,7	to	267	3,5	3,0
273	to	457,2	4,0	3,5
		508	4,5	4,0

3.2 Heat treatment

3.2.1 Pipes which have been hardened by cold bending are to be suitably heat treated on completion of fabrication and prior to being tested by hydraulic pressure. Copper pipes are to be annealed and copper alloy pipes are to be either annealed or stress relief heat treated.

Section 4 Cast iron

4.1 Spheroidal or nodular graphite cast iron

4.1.1 Spheroidal or nodular graphite iron may be accepted for bilge, ballast and cargo oil piping.

4.1.2 Spheroidal or nodular graphite iron castings for pipes, valves and fittings in Class II and Class III piping systems are to be made in a grade having a specified minimum elongation not less than 12 per cent on a gauge length of $5,65 \sqrt{S_o}$, where S_o is the actual cross-sectional area of the test piece.

4.1.3 Castings for Class II systems, also for ship-side valves and fittings and valves on the collision bulkhead, are to be manufactured and tested in accordance with the requirements of *Ch 7 Iron Castings* of the Rules for Materials.

4.1.4 Castings for Class III systems are to comply with the requirements of acceptable national specifications. A manufacturer's certificate will be accepted and is to be provided for each consignment of material for Class III systems, see *also Pt 5, Ch 12, 1.7 Materials* and *Ch 1, 3.1 General 3.1.3* of the Rules for Materials.

4.1.5 Proposals for the use of this material in Class I piping systems will be specially considered, but in no case is the material to be used in systems where the design temperature exceeds 350°C.

4.1.6 Where the elongation is less than the minimum required by *Pt 5, Ch 12, 4.1 Spheroidal or nodular graphite cast iron 4.1.2*, the material is, in general, to be subject to the same limitations as grey cast iron.

4.2 Grey cast iron

4.2.1 Grey cast iron pipes, valves and fittings will, in general, be accepted in Class III piping systems except as stated in *Pt 5, Ch 12, 4.2 Grey cast iron 4.2.3*.

4.2.2 Grey cast iron is not to be used for pipes, valves and other fittings handling media having temperatures above 220°C or for piping subject to pressure shock, excessive strains or vibrations.

4.2.3 Grey cast iron is not to be used for the following:

- Pipes for steam systems and fire extinguishing systems.
- Pipes, valves and fittings for boiler blow-down systems and other piping systems subject to shock or vibration.
- Ship-side valves and fittings, see *Pt 5, Ch 13, 2.5 Ship-side valves and fittings (other than those on scuppers and sanitary discharges)*.
- Valves fitted on the collision bulkhead, see *Pt 5, Ch 13, 3.5 Fore and after peaks*.
- Bilge lines in tanks.
- Piping system components in flammable oil systems where the design pressure exceeds 7 bar or the design operating temperature is greater than 60°C.
- Valves fitted to tanks containing flammable oil under static pressure.
- Valve chests and fittings for starting air systems, see *Pt 5, Ch 2, 8.3 Starting air pipe systems and safety fittings 8.3.4*.
- Manifolds and their valves and fittings on tankers that connect to cargo-handling hoses.

4.2.4 Castings for Class III piping systems are to comply with acceptable National Specifications.

■ **Section 5 Plastics pipes**

5.1 General

5.1.1 Proposals to use plastics pipes in shipboard piping systems will be considered in relation to the properties of the materials, the operating conditions, the intended service and location. Details are to be submitted for approval. Special consideration will be given to any proposed service for plastics pipes not mentioned in these Rules.

5.1.2 Attention is also to be given to the *Guidelines for the Application of Plastic Pipes on Ships* contained in *IMO Resolution A.753(18) - Guidelines for the Application of Plastic Pipes on Ships - (adopted on 4 November 1993) Amended by Resolution MSC.313(88)*.

5.1.3 Plastics pipes and fittings will, in general, be accepted in Class III piping systems. Proposals for the use of plastics in Class I and Class II piping systems will be specially considered.

5.1.4 For Class I, Class II and any Class III piping systems for which there are Rule requirements, the pipes are to be of a type which has been approved by LR.

5.1.5 For domestic and similar services where there are no Rule requirements, the pipes need not be of a type which has been approved by LR. However, the fire safety aspects as referenced in *Pt 5, Ch 12, 5.4 Fire performance criteria*, are to be considered.

5.1.6 The use of plastics pipes may be restricted by statutory requirements of the National Authority of the country in which the ship is to be registered.

5.2 Design and performance criteria

5.2.1 Pipes and fittings are to be of robust construction and are to comply with a National or other established Standard, consistent with the intended use. Particulars of pipes, fittings and joints are to be submitted for consideration.

5.2.2 The design and performance criteria of all piping systems, independent of service or location, are to meet the requirements of *Pt 5, Ch 12, 5.3 Design strength*.

5.2.3 Depending on the service and location, the fire safety aspects are to meet the requirements of *Pt 5, Ch 12, 5.4 Fire performance criteria*.

5.2.4 Plastics piping, connections and fittings are to be electrically conductive when:

- (a) carrying fluids capable of generating electrostatic charges.
- (b) passing through hazardous zones and spaces, regardless of the fluid being conveyed.

Suitable precautions against the build up of electrostatic charges are to be provided in accordance with the requirements of *Pt 5, Ch 12, 5.5 Electrical conductivity, see also Pt 6, Ch 2, 1.13 Bonding for the control of static electricity*.

5.3 Design strength

5.3.1 The strength of pipes is to be determined by hydrostatic pressure tests to failure on representative sizes of pipe. The strength of fittings is to be not less than the strength of the pipes.

5.3.2 The nominal internal pressure, pN_i , of the pipe is to be determined by the lesser of the following:

$$pN_i \leq \frac{p_{st}}{4}$$

$$pN_i \leq \frac{p_{lt}}{2,5}$$

where

p_{st} = short term hydrostatic test failure pressure, in bar

p_{lt} = long term hydrostatic test failure pressure (100 000 hours), in bar

Testing may be carried out over a reduced period of time using suitable Standards, such as ASTM D2837 and D1598.

5.3.3 The nominal external pressure, pN_e , of the pipe, defined as the maximum total of internal vacuum and external static pressure head to which the pipe may be subjected, is to be determined by the following:

$$pN_e \leq \frac{p_{col}}{3}$$

where

p_{col} = pipe collapse pressure, in bar

The pipe collapse pressure is not to be less than 3 bar.

5.3.4 Piping is to meet these design requirements over the range of service temperature it will experience.

5.3.5 High temperature limits and pressure reductions relative to nominal pressures are to be according to a recognised standard, but in each case the maximum working temperature is to be at least 20°C lower than the minimum temperature of deflection under load of the resin or plastics material without reinforcement. The minimum heat distortion temperature is not to be less than 80°C, *see also Ch 14, 4 Plastics pipes and fittings* of the Rules for Materials.

5.3.6 Where it is proposed to use plastics piping in low temperature services, design strength testing is to be made at a temperature 10°C lower than the minimum working temperature.

5.3.7 For guidance, typical temperature and pressure limits are indicated in *Table 12.5.1 Typical temperature and pressure limits for thermoplastic pipes* and *Table 12.5.2 Typical temperature and pressure limits for glassfibre reinforced epoxy (GRE) and*

polyester (GRP) pipes. The Tables are related to water service only. Transport of chemicals or other media is to be considered on a case by case basis.

Table 12.5.1 Typical temperature and pressure limits for thermoplastic pipes

Material	Nominal pressure, bar	Maximum permissible working pressure, bar						
		-20 to 0°C	30°C	40°C	50°C	60°C	70°C	80°C
PVC	10		7,5	6				
	16		12	9	6			
ABS	10	7,5	7,5	7	6			
	16	12	12	10,5	9	7,5	6	
HDPE	10	7,5	6					
	16	12	9,5	6				
Abbreviations								
PVC	Polyvinyl chloride							
ABS	Acrylonitrile - butadiene - styrene							
HDPE	High density polyethylene							

Table 12.5.2 Typical temperature and pressure limits for glassfibre reinforced epoxy (GRE) and polyester (GRP) pipes

Minimum heat distortion temperature of resin	Nominal pressure, bar	Maximum permissible working pressure, bar							
		-50 to 30°C	40°C	50°C	60°C	70°C	80°C	90°C	95°C
80°C	10	10	9	7,5	6				
	16	16	14	12	9,5				
	25	16	16	16	15				
100°C	10	10	10	9,5	8,5	7	6		
	16	16	16	15	13,5	11	9,5		
	25	16	16	16	16	16	15		
135°C	10	10	10	10	10	9,5	8,5	7	6
	16	16	16	16	16	15	13,5	11	9,5
	25	16	16	16	16	16	16	16	15

5.3.8 The selection of plastics materials for piping is to take account of other factors such as impact resistance, ageing, fatigue, erosion resistance, fluid absorption and material compatibility such that the design strength of the piping is not reduced below that required by these Rules.

5.3.9 Design strength values may be verified experimentally or by a combination of testing and calculation methods.

5.4 Fire performance criteria

5.4.1 Where plastics pipes are used in systems essential to the safe operation of the ship, or for containing combustible liquids or sea-water where leakage or failure could result in fire or in the flooding of watertight compartments, the pipes and fittings are to be of a type which have been fire endurance tested in accordance with the requirements of *Table 12.5.3 Fire endurance requirements*.

5.4.2 Where a fire protective coating of pipes and fittings is necessary for achieving the fire endurance standards required, the coating is to be resistant to products likely to come into contact with the piping and be suitable for the intended application.

5.5 Electrical conductivity

5.5.1 Where a piping system is required to be electrically conductive for the control of static electricity, the resistance per unit length of the pipe, bends, elbows, fabricated branch pieces, etc. is not to exceed 0,1 M Ω /m, see also *Pt 5, Ch 12, 5.2 Design and performance criteria 5.2.4*.

5.5.2 Electrical continuity is to be maintained across the joints and fittings and the system is to be earthed, see also *Pt 6, Ch 2, 1.13 Bonding for the control of static electricity*. The resistance to earth from any point in the piping system is not to exceed 1 M Ω .

Piping Design Requirements

Part 5, Chapter 12

Section 5

Table 12.5.3 Fire endurance requirements

	Location										
	A	B	C	D	E	F	G	H	I	J	K
Piping systems	Machinery spaces of Category A	Other machinery spaces and pump rooms	Cargo pump rooms	Ro-Ro cargo holds	Other dry cargo holds	Cargo tanks	Fuel oil tanks	Ballast water tanks	Cofferdams void spaces pipe tunnel and ducts	Accommodation service and control spaces	Open decks
CARGO (FLAMMABLE CARGOES S.f.p. ≤ 60°C)											
1 Cargo lines	N/A	N/A	L1	N/A	N/A	0	N/A	0 ¹⁰	0	N/A	L1 ²
2 Crude oil washing lines	N/A	N/A	L1	N/A	N/A	0	N/A	0 ¹⁰	0	N/A	L1 ²
3 Vent lines	N/A	N/A	N/A	N/A	N/A	0	N/A	0 ¹⁰	0	N/A	X
INERT GAS											
4 Water seal effluent line	N/A	N/A	0 ¹	N/A	N/A	0 ¹	0 ¹	0 ¹	0 ¹	N/A	0
5 Scrubber effluent line	0 ¹	0 ¹	N/A	N/A	N/A	N/A	N/A	0 ¹	0 ¹	N/A	0
6 Main line	0	0	L1	N/A	N/A	N/A	N/A	N/A	0	N/A	L1 ⁶
7 Distribution lines	N/A	N/A	L1	N/A	N/A	0	N/A	N/A	0	N/A	L1 ²
FLAMMABLE LIQUIDS (f.p. > 60°C)											
8 Cargo lines	X	X	L1	X	X	N/A ³	0	0 ¹⁰	0	N/A	L1
9 Fuel oil	X	X	L1	X	X	N/A ³	0	0	0	L1	L1

Piping Design Requirements

Part 5, Chapter 12

Section 5

10 Lubricating oil	X	X	L1	X	X	N/A	N/A	N/A	0	L1	L1
11 Hydraulic oil	X	X	L1	X	X	0	0	0	0	L1	L1
SEA-WATER ¹											
12 Bilge main and branches	L1 ⁷	L1 ⁷	L1	X	X	N/A	0	0	0	N/A	L1
13 Fire main and water spray	L1	L1	L1	X	N/A	N/A	N/A	0	0	X	L1
14 Foam system	L1	L1	L1	N/A	N/A	N/A	N/A	N/A	0	L1	L1
15 Sprinkler system	L1	L1	L3	X	N/A	N/A	N/A	0	0	L3	L3
16 Ballast	L3	L3	L3	L3	X	0 ¹⁰	0	0	0	L2	L2
17 Cooling water, essential services	L3	L3	N/A	N/A	N/A	N/A	N/A	0	0	N/A	L2
18 Tank cleaning services fixed machines	N/A	N/A	L3	N/A	N/A	0	N/A	0	0	N/A	L3 ²
19 Non-essential systems	0	0	0	0	0	N/A	0	0	0	0	0
FRESH WATER											
20 Cooling water essential services	L3	L3	N/A	N/A	N/A	N/A	0	0	0	L3	L3
21 Condensate return	L3	L3	L3	0	0	N/A	N/A	N/A	0	0	0
22 Non-essential systems	0	0	0	0	0	N/A	0	0	0	0	0

Piping Design Requirements

Part 5, Chapter 12

Section 5

SANITARY/ DRAINS/ SCUPPERS											
23 Deck drains (internal)	L1 ⁴	L1 ⁴	N/A	L1 ⁴	0	N/A	0	0	0	0	0
24 Sanitary drains (internal)	0	0	N/A	0	0	N/A	0	0	0	0	0
25 Scuppers and discharges (overboard)	0 ^{1,8}	0 ^{1,8}	0 ^{1,8}	0 ^{1,8}	0 ^{1,8}	0	0	0	0	0 ^{1,8}	0
SOUNDING/AIR											
26 Water tanks/dry spaces	0	0	0	0	0	0 ¹⁰	0	0	0	0	0 ¹¹
27 Oil tanks (f.p. > 60°C)	X	X	X	X	X	X ³	0	0 ¹⁰	0	X	X
MISCELLANEOUS											
28 Control air	L1 ⁵	L1 ⁵	L1 ⁵	L1 ⁵	L1 ⁵	N/A	0	0	0	L1 ⁵	L1 ⁵
29 Service air (non-essential)	0	0	0	0	0	N/A	0	0	0	0	0
30 Brine	0	0	N/A	0	0	N/A	N/A	N/A	0	0	0
31 Auxiliary low pressure steam (≤ 7 bar)	L2	L2	0 ⁹	0 ⁹	0 ⁹	0	0	0	0	0 ⁹	0 ⁹
LOCATION DEFINITIONS											
Location			Definition								
A Machinery spaces of Category A			Machinery spaces of Category A as defined in SOLAS* regulation II-2/3.19.								

B Other machinery spaces and pump rooms	Spaces, other than Category A machinery spaces and cargo pump rooms, containing propulsion machinery, boilers, steam and internal combustion engines, generators and major electrical machinery, pumps, oil filling stations, refrigerating, stabilising, ventilation and air-conditioning machinery, and similar spaces, and trunks to such spaces.
C Cargo pump rooms	Spaces containing cargo pumps and entrances and trunks to such spaces.
D Ro-Ro cargo holds	Ro-Ro cargo holds are Ro-Ro cargo spaces and special category spaces as defined in SOLAS* regulation II-2/3.14 and 3.18.
E Other dry cargo holds	All spaces other than Ro-Ro cargo holds used for non-liquid cargo and trunks to such spaces.
F Cargo tanks	All spaces used for liquid cargo and trunks to such spaces.
G Fuel oil tanks	All spaces used for fuel oil (excluding cargo tanks) and trunks to such spaces.
H Ballast water tanks	All spaces used for ballast water and trunks to such spaces.
I Cofferdams, voids, etc.	Cofferdams and voids are those empty spaces between two bulkheads separating two adjacent compartments.
J Accommodation, service	Accommodation spaces, service spaces and control stations as defined in SOLAS* regulation II-2/3.10, 3.12, 3.22.
K Open decks	Open deck spaces, as defined in SOLAS* regulation II-2/26.2.2(5).
* SOLAS 74 as amended by the 1978 SOLAS Protocol and the 1981 and 1983 amendments (consolidated text).	
ABBREVIATIONS	
L1 Fire endurance test in dry conditions, 60 minutes, IMO Resolution A.753(18) <i>Appendix 1 - Test Method for Fire Endurance Testing of Plastic Piping in the Dry Condition.</i>	
L2 Fire endurance test in dry conditions, 30 minutes, IMO Resolution A.753(18) <i>Appendix 1 - Test Method for Fire Endurance Testing of Plastic Piping in the Dry Condition.</i>	
L3 Fire endurance test in wet conditions, 30 minutes, IMO Resolution A.753(18) <i>Appendix 2 - Test Method for Fire Endurance Testing of Water-Filled Plastic Piping.</i>	
O No fire endurance test required.	
Not applicable.	
X Metallic materials having a melting point greater than 925°C.	
Note 1. Where non-metallic piping is used, remotely controlled valves to be provided at ship's side (valve is to be controlled from outside space).	
Note 2. Remote closing valves to be provided at the cargo tanks.	
Note 3. When cargo tanks contain flammable liquids with f.p. > 60°C, 'O' may replace 'N/A' or 'X'.	
Note 4. For drains serving only the space concerned, 'O' may replace 'L1'.	
Note 5. When controlling functions are not required by the Rules or statutory requirements, 'O' may replace 'L1'.	
Note 6. For pipe between machinery space and deck water seal, 'O' may replace 'L1'.	
Note 7. For passenger vessels, 'X' is to replace 'L1'.	
Note 8. Scuppers serving open decks in positions 1 and 2, as defined in <i>Regulation 13 - Position of hatchways, doorways and ventilators of the Load Lines, 1966/1988 - International Convention on Load Lines, 1966, as Amended by the Protocol of 1988</i> , should be 'X' throughout unless fitted at the upper end with the means of closing capable of being operated from a position above the freeboard deck in order to prevent downflooding.	
Note 9. For essential services, such as fuel oil tank heating and ship's whistle, 'X' is to replace 'O'.	

Note 10. For tankers where compliance with MARPOL Annex I, *Regulation 19 - Double hull and double bottom requirements for oil tankers delivered on or after 6 July 1996* .3.6 is required, 'N/A' is to replace '0'.

Note 11. Air and sounding pipes on open deck are to be of substantial construction, see *Pt 5, Ch 13, 10.2 Ships with auxiliary power 10.2.2*.

5.6 Manufacture and quality control

5.6.1 All materials for plastics pipes and fittings are to be approved by LR, and are in general to be tested in accordance with *Ch 14, 4 Plastics pipes and fittings* of the Rules for Materials. For pipes and fittings not employing hand lay up techniques, the hydrostatic pressure test required by *Ch 14, 4.9 Hydraulic test* of the Rules for Materials may be replaced by testing carried out in accordance with the requirements stipulated in a National or International Standard, consistent with the intended use for which the pipe or fittings are manufactured, provided there is an effective quality system in place complying with the requirements of *Ch 14, 4.4 Quality assurance* of the Rules for Materials and the testing is completed to the satisfaction of the LR Surveyor.

5.6.2 The material manufacturer's test certificate, based on actual tested data, is to be provided for each batch of material.

5.6.3 Plastics pipes and fittings are to be manufactured at a works approved by LR in accordance with agreed quality control procedures which shall be capable of detecting at any stage (e.g. incoming material, production, finished article, etc.) deviations in the material, product or process.

5.6.4 Plastics pipes are to be manufactured and tested in accordance with *Ch 14, 4 Plastics pipes and fittings* of the Rules for Materials. For Class III piping systems the pipe manufacturer's test certificate may be accepted in lieu of an LR Certificate and is to be provided for each consignment of pipe.

5.7 Installation and construction

5.7.1 All pipes are to be adequately but freely supported. Suitable provision is to be made for expansion and contraction to take place without unduly straining the pipes.

5.7.2 Pipes may be joined by mechanical couplings or by bonding methods such as welding and laminating.

5.7.3 Where bonding systems are used, the manufacturer or installer shall provide a written procedure covering all aspects of installation, including temperature and humidity conditions. The bonding procedure is to be approved by LR.

5.7.4 The person carrying out the bonding is to be qualified. Records are to be available to the Surveyor for each qualified person showing the bonding procedure and performance qualification, together with dates and results of the qualification testing.

5.7.5 In the case of pipes intended for essential services each qualified person is, at the place of construction, to make at least one test joint, representative of each type of joint to be used. The joined pipe section is to be tested to an internal hydrostatic pressure of four times the design pressure of the pipe system and the pressure held for not less than one hour, with no leakage or separation of joints. The bonding procedure test is to be witnessed by the Surveyor.

5.7.6 Conditions during installation, such as temperature and humidity, which may affect the strength of the finished joints, are to be in accordance with the agreed bonding procedure.

5.7.7 The required fire endurance level of the pipe is to be maintained in way of pipe supports, joints and fittings, including those between plastics and metallic pipes.

5.7.8 Where piping systems are arranged to pass through watertight bulkheads or decks, provision is to be made for maintaining the integrity of the bulkhead or deck by means of metallic bulkhead, or deck, pieces. The bulkhead pieces are to be protected against corrosion, and so constructed to be of a strength equivalent to the intact bulkhead; attention is drawn to *Pt 5, Ch 12, 5.7 Installation and construction 5.7.1, see also Pt 5, Ch 13, 2.4 Attachment of valves to watertight plating 2.4.1*. Details of the arrangements are to be submitted for approval.

5.7.9 Where a piping system is required to be electrically conductive, for the control of static electricity, continuity is to be maintained across the joints and fittings, and the system is to be earthed, see also *Pt 6, Ch 2, 1.13 Bonding for the control of static electricity*.

5.8 Testing

5.8.1 The hydraulic testing of pipes and fittings is to be in accordance with *Pt 5, Ch 12, 8 Hydraulic tests on pipes and fittings*.

5.8.2 Where a piping system is required to be electrically conductive, tests are to be carried out to verify that the resistance to earth from any point in the system does not exceed 1 MΩ, see also *Pt 6, Ch 2, 21.2 Trials 21.2.3*.

■ Section 6 Valves

6.1 Design requirements

6.1.1 The design, construction and operational capability of valves is to be in accordance with an acceptable National or International Standard appropriate to the piping system. Where valves are not in accordance with an acceptable standard, details are to be submitted for consideration. Where valves are fitted, the requirements of *Pt 5, Ch 12, 6.1 Design requirements 6.1.2* are to be satisfied.

6.1.2 Valves are to be made of steel, cast iron, copper alloy, or other approved material suitable for the intended purpose.

6.1.3 Valves having isolation or sealing components sensitive to heat are not to be used in spaces where leakage or failure caused by fire could result in fire spread, flooding or the loss of an essential service.

6.1.4 Where valves are required to be capable of being closed remotely in the event of fire, the valves, including their controlgear, are to be of steel construction or of an acceptable fire tested design.

6.1.5 Valves are to be arranged for clockwise closing and are to be provided with indicators showing whether they are open or shut unless this is readily obvious. Legible nameplates are to be fitted.

6.1.6 Valves are to be so constructed as to prevent the possibility of valve covers or glands being slackened back or loosened when the valves are operated.

6.1.7 Valves are to be used within their specified pressure and temperature rating for all normal operating conditions, and are to be suitable for the intended purpose.

6.1.8 Valves intended for submerged installation are to be suitable for both internal and external media. Spindle sealing is to prevent ingress of external media at the maximum external pressure head expected in service.

■ Section 7 Flexible hoses

7.1 General

7.1.1 A flexible hose assembly is a short length of metallic or non-metallic hose normally with prefabricated end fittings ready for installation.

7.1.2 For the purpose of approval for the applications in *Pt 5, Ch 12, 7.2 Applications*, details of the materials and construction of the hoses, and the method of attaching the end fittings together with evidence of satisfactory prototype testing, are to be submitted for consideration.

7.1.3 The use of hose clamps and similar types of end attachments are not to be used for flexible hoses in piping systems for steam, flammable media, starting air systems or for sea-water systems where failure may result in flooding. In other piping systems, the use of hose clamps may be accepted where the working pressure is less than 5 bar and provided that there are two clamps at each end connection.

7.1.4 Flexible hoses are to be limited to a length necessary to provide for relative movement between fixed and flexibly mounted items of machinery/equipment or systems.

7.1.5 Flexible hoses are not to be used to compensate for misalignment between sections of piping.

7.1.6 Flexible hose assemblies are not to be installed where they may be subjected to torsional deformation (twisting) under normal operating conditions.

7.1.7 The number of flexible hoses in piping systems mentioned in this Section is to be kept to a minimum and to be limited for the purpose stated in *Pt 5, Ch 12, 7.2 Applications 7.2.1*.

7.1.8 Where flexible hoses are intended for conveying flammable fluids in piping systems that are in close proximity to hot surfaces, electrical installation or other sources of ignition, the risk of ignition due to failure of the hose assembly and subsequent release of fluids is to be mitigated as far as practicable by the use of screens or other suitable protection.

7.1.9 Flexible hoses are to be installed in clearly visible and readily accessible locations.

7.1.10 The installation of flexible hose assemblies is to be in accordance with the manufacturer's instructions and use limitations with particular attention to the following:

- (a) Orientation.
- (b) End connection support (where necessary).
- (c) Avoidance of hose contact that could cause rubbing and abrasion.
- (d) Minimum bend radii.

7.1.11 Flexible hoses are to be permanently marked by the manufacturer with the following details:

- (a) Hose manufacturer's name or trademark.
- (b) Date of manufacture (month/year).
- (c) Designation type reference.
- (d) Nominal diameter.
- (e) Pressure rating
- (f) Temperature rating.

Where a flexible hose assembly is made up of items from different manufacturers, the components are to be clearly identified and traceable to evidence of prototype testing.

7.2 Applications

7.2.1 Short joining lengths of flexible hoses complying with the requirements of this Section may be used, where necessary, to accommodate relative movement between various items of machinery connected to permanent piping systems. The requirements of this Section may also be applied to temporarily-connected flexible hoses or hoses of portable equipment.

7.2.2 Rubber or plastics hoses, with integral cotton or similar braid reinforcement, may be used in fresh and sea-water cooling systems. In the case of sea-water systems, where failure of the hoses could give rise to the danger of flooding, the hoses are to be suitably enclosed, as indicated in *Pt 5, Ch 13, 2.7 Provision for expansion*.

7.2.3 Rubber hoses, with single, double or more closely woven integral wire braid or other suitable material reinforcement, or convoluted metal pipes with wire braid protection, may be used in bilge, ballast, compressed air, fresh water, sea-water, fuel oil, lubricating oil, Class III steam, hydraulic and thermal oil systems. Flexible hoses of plastics materials for the same purposes, such as Teflon or Nylon, which are unable to be reinforced by incorporating closely woven integral wire braid are to have suitable material reinforcement as far as practicable. Where rubber or plastics hoses are used for fuel oil supply to burners, the hoses are to have external wire braid protection in addition to the integral wire braid. Flexible hoses for use in steam systems are to be of metallic construction.

7.2.4 Flexible hoses are not to be used in high pressure fuel oil injection systems.

7.2.5 The requirements in this section for flexible hose assemblies are not applicable to hoses intended to be used in fixed fire-extinguishing systems.

7.3 Design requirements

7.3.1 Flexible hose assemblies are to be designed and constructed in accordance with recognised National or International Standards acceptable to LR.

7.3.2 Flexible hoses are to be complete with approved end fittings in accordance with manufacturer's specification. End connections which do not have flanges are to comply with *Pt 5, Ch 12, 2.12 Other mechanical couplings* as applicable and each type of hose/fitting combination is to be subject to prototype testing to the same standard as that required by the hose with particular reference to pressure and impulse tests.

7.3.3 Flexible hose assemblies intended for installation in piping systems where pressure pulses and/or high levels of vibration are expected to occur in service, are to be designed for the maximum expected impulse peak pressure and forces due to

vibration. The tests required by *Pt 5, Ch 12, 7.4 Testing* are to take into consideration the maximum anticipated in-service pressures, vibration frequencies and forces due to installation.

7.3.4 Flexible hose assemblies constructed of nonmetallic materials intended for installation in piping systems for flammable media, and sea-water systems where failure may result in flooding, are to be of fire-resistant type. Fire resistance is to be demonstrated by testing to ISO 15540 and ISO 15541.

7.3.5 Flexible hose assemblies are to be suitable for the intended location and application, taking into consideration ambient conditions, compatibility with fluids under working pressure and temperature conditions consistent with the manufacturer's instructions and any other applicable requirements in the Rules.

7.4 Testing

7.4.1 Acceptance of flexible hose assemblies is subject to satisfactory prototype testing. Prototype test programmes for flexible hose assemblies are to be submitted by the manufacturer and are to be sufficiently detailed to demonstrate performance in accordance with the specified Standards.

7.4.2 For a particular hose type complete with end fittings, the tests, as applicable, are to be carried out on different nominal diameters for pressure, burst, impulse and fire resistance in accordance with the requirements of the relevant Standard. The following Standards are to be used as applicable:

- ISO 6802 – *Rubber and plastics hoses and hose assemblies with wire reinforcements – Hydraulic impulse test with flexing.*
- ISO 6803 – *Rubber or plastics hoses and hose assemblies – Hydraulic – pressure impulse test without flexing.*
- ISO 15540 – *Ships and marine technology – Fire resistance of hose assemblies – Test methods.*
- ISO 15541 – *Ships and marine technology – Fire resistance of hose assemblies – Requirements for test bench.*
- ISO 10380 – *Pipework – Corrugated metal hoses and hose assemblies.*

Other Standards may be accepted where agreed by LR.

7.4.3 All flexible hose assemblies are to be satisfactorily prototype burst tested to an International Standard* to demonstrate they are able to withstand a pressure of not less than four times the design pressure without indication of failure or leakage.

Note * The International Standards, e.g. EN or SAE for burst testing of non-metallic hoses, require the pressure to be increased until burst without any holding period at 4 x Maximum Working Pressure.

■ Section 8 Hydraulic tests on pipes and fittings

8.1 Hydraulic tests before installation on board

8.1.1 All Class I and II pipes and their associated fittings are to be tested by hydraulic pressure to the Surveyor's satisfaction. Further, all steam, feed, compressed air and fuel oil pipes, together with their fittings, are to be similarly tested where the design pressure is greater than 7,0 bar. The test is to be carried out after completion of manufacture and before installation on board and, where applicable, before insulating and coating.

8.1.2 Where the design temperature does not exceed 300°C, the test pressure is to be 1,5 times the design pressure, as defined in *Pt 5, Ch 12, 1.4 Design pressure*.

8.1.3 Where testing of systems or sub-systems following final assembly is specified, in addition to the requirements of *Pt 5, Ch 12, 8.1 Hydraulic tests before installation on board 8.1.2* the lowest applicable pressure as defined in this sub-Section is to be used for testing.

8.1.4 For steel pipes and integral fittings for use in systems where the design temperature exceeds 300°C, the test pressure is to be as follows:

- (a) For carbon and carbon-manganese steel pipes, the test pressure is to be twice the design pressure, as defined in *Pt 5, Ch 12, 1.4 Design pressure*.
- (b) For alloy steel pipes, the test pressure is to be determined by the following formula, but need not exceed $2p$:

$$p_t = 1,5 \frac{\sigma}{\sigma} \frac{100}{\sigma} p \quad \text{bar} (\text{kgf/cm}^2)$$

= where p_t and p are as defined in *Pt 5, Ch 12, 1.3 Design symbols 1.3.2*

σ = permissible stress for the design temperature, in N/mm² (kgf/cm²), as stated in *Table 12.2.2 Alloy steel pipes*.

σ_{100} = permissible stress for 100°C, in N/mm² (kgf/cm²), as stated in *Table 12.2.2 Alloy steel pipes*.

8.1.5 Where alloy steels not included in *Table 12.2.2 Alloy steel pipes* are used, the permissible stresses will be specially considered, as indicated in *Pt 5, Ch 12, 2.2 Wrought steel pipes and bends 2.2.2*.

8.1.6 Consideration will be given to the reduction of the test pressure to not less than 1,5 p , where it is necessary to avoid excessive stress in way of bends, branches, etc.

8.1.7 Valves and fittings non-integral with the piping system, intended for Classes I and II, are to be tested in accordance with recognised standards, but to not less than 1,5 times the design pressure. Where design features are such that modifications to the test requirements are necessary, alternative proposals for hydraulic tests are to be submitted for special consideration.

8.1.8 For requirements relating to valves and cocks intended to be fitted on the ship's side below the load water line, see *Pt 5, Ch 13, 2.5 Ship-side valves and fittings (other than those on scuppers and sanitary discharges) 2.5.10*.

8.1.9 In no case is the membrane stress to exceed 90 per cent of the yield stress at the testing temperature.

8.2 Testing after assembly on board

8.2.1 Heating coils in tanks, gas fuel and fuel oil piping are to be tested by hydraulic pressure, after installation on board, to 1,5 times the design pressure but in no case to less than 4 bar (4,1 kgf/cm²).

8.2.2 Where pipes specified in *Pt 5, Ch 12, 8.1 Hydraulic tests before installation on board 8.1.1* are butt welded together during assembly on board, they are to be tested by hydraulic pressure in accordance with the requirements of *Pt 5, Ch 12, 8.1 Hydraulic tests before installation on board* after welding. The pipe lengths may be insulated, except in way of the joints made during installation and before the hydraulic test is carried out.

8.2.3 The hydraulic test required by *Pt 5, Ch 12, 8.2 Testing after assembly on board 8.2.2* may be omitted provided non-destructive tests by ultrasonic or radiographic methods are carried out on the entire circumference of all butt welds with satisfactory results. Where ultrasonic tests have been carried out, the manufacturer is to provide the Surveyor with a signed statement confirming that ultrasonic examination has been carried out by an approved operator and that there were no indications of defects which could be expected to have a prejudicial effect on the service performance of the piping.

8.2.4 Where bilge pipes are accepted in way of double bottom tanks or deep tanks, see *Pt 5, Ch 13, 7.9 Bilge pipes in way of double bottom tanks* and *Pt 5, Ch 13, 7.10 Bilge pipes in way of deep tanks*, the pipes after fitting are to be tested by hydraulic pressure to the same pressure as the tanks through which they pass.

■ **Cross-reference**

See also *Pt 5, Ch 13, 2.10 Testing after installation* for testing after installation.

■ **Section 9 Piping for LPG/LNG carriers, gas fuelled ships and classed refrigeration systems**

9.1 Scope

9.1.1 This Section is applicable to piping systems installed in LPG/LNG carriers, gas fuelled ships and classed refrigeration systems for the following pipes and piping system components:

- (a) Pipework – stainless steel, carbon steel and copper.
- (b) Valves – normal and cryogenic service (below minus 55°C).
- (c) Bellows – normal and cryogenic service (below minus 55°C).

- (d) Pipe fittings – elbows, reducers, tee connections, etc.
- (e) Ancillary fittings – weldolets, threadolets, thermopockets.

9.1.2 The following piping systems are covered by this Section:

- (a) LPG/LNG cargo systems – normal cargo operations.
- (b) LPG/LNG cargo systems – cargo gas to reliquefaction system.
- (c) LNG cargo systems – gas burning and use of cargo as fuel.
- (d) LNG Regasification system – high and low pressure.
- (e) Cargo Reliquefaction system – nitrogen or mixed refrigerant.
- (f) Refrigeration – independent plant used in cascade systems.
- (g) Gas storage and supply systems for gas fuelled ships.

9.2 Application

9.2.1 The requirements of this Section apply to pipes and piping system components, such as valves, elbows and bellows, which are to be used on gas carriers, gas fuelled ships or classed refrigeration/reliquefaction systems. The requirements are also applicable to other gas cargo services such as regasification systems and gas combustion units, and are in addition to those contained in both the Rules for Ships for Liquefied Gases and relevant Sections of this Chapter where appropriate.

9.3 Classes of pipe

9.3.1 The material requirements for piping systems vary depending on the Class of the piping system. The Class of the piping system is dependent on the design pressure or temperature of the system and the pipe material used as shown in *Table 12.1.1 Maximum pressure and temperature conditions for Class II and III piping systems*.

9.3.2 *Table 12.1.1 Maximum pressure and temperature conditions for Class II and III piping systems* shows piping systems containing LPG/LNG, cargo or fuel gas as the conveyed medium are to be treated as 'Flammable liquids'. These piping systems are to be categorised as Class II. Vapour lines are also to be categorised as Class II systems but the upper limit on pressure may be increased to 4 MPa gauge in accordance with the 'Other media'. Where higher design pressures are applied, such as in a regasification system, liquid lines above 1,6 MPa gauge and vapour lines above 4 MPa gauge are to be categorised as Class I. All open ended pipes, such as vent lines and pipes inside the cargo tanks may be categorised as Class III, provided that the temperature of the cargo at the pressure relief valve setting is not colder than minus 55°C.

9.3.3 For reliquefaction and refrigeration systems *Table 12.1.1 Maximum pressure and temperature conditions for Class II and III piping systems* is to be applied. Nitrogen and non-toxic or nonflammable refrigerants are to be considered under the 'Other media' heading. Refrigeration systems containing ammonia are to be considered as Class I systems irrespective of the operational pressure.

9.4 Materials

9.4.1 Stainless steel pipes, valves and fittings for welded fabrication are to be grades 304L, 316L, 321 or 347 in accordance with *Ch 6, 5 Stainless steel pressure Pipes* of the Rules for Materials. For non-welded fabrications the grades 304 and 316 may be accepted.

9.4.2 The materials used in Class I and Class II systems are to be produced at a works approved by LR. Testing is to be in accordance with the Rules for Materials and *Table 1.7*, and *Table 1.7*, in chapter 6 of the Rules for Ships for Liquefied Gases.

9.4.3 For stainless steel pipes, valve castings and forgings, a manufacturer's certificate is acceptable where the intended service temperature is not colder than minus 55°C and:

- $DN < 50$ or
- $DN \leq 150$ and $DN \times P < 250$

Where:

DN = nominal diameter, mm

P = design pressure, in MPa gauge

In all other cases, an LR materials certificate is required.

9.5 Valves and piping components independent of temperature

9.5.1 For valves and piping components fitted in the cargo piping system of LPG/LNG gas carriers, each type of valve and piping component is to have evidence of satisfactory type testing.

9.6 Valves for cryogenic temperature service

9.6.1 Each size and type of valve intended to be used at a working temperature below -55°C shall be approved. Approval is based upon prototype testing and assessment of the design for compliance with a recognised national or international standard acceptable to LR.

9.6.2 The tightness test required by *Process Pressure Vessels and Liquid, Vapour and Pressure Piping Systems* of the Rules for Ships for Liquefied Gases is to be conducted in accordance with a recognised National or International Code or Standard.

9.7 Valves for refrigeration service

9.7.1 For valves intended for installation in a refrigeration system with a nominal diameter equal to or less than 150 mm, a manufacturer's certificate is acceptable. The certificate is to include details of the maximum working pressure and test pressure, and sufficient information for the LR Surveyor to assess the suitability of the equipment for the intended use. Each size and type of valve is to be supplied with its own certificate and is to be signed by a responsible person in the manufacturer's quality control department.

9.7.2 Valves with nominal diameters above 150 mm are to be supplied with a LR materials certificate in accordance with the Rules for Materials.

9.7.3 Where valves are fitted to pressure vessels, the requirements of *Pt 5, Ch 10 Steam Raising Plant and Associated Pressure Vessels* and *Pt 5, Ch 11 Other Pressure Vessels* are applicable for the Class of pressure vessel. Mountings for liquefied gas pressure vessels are to comply with the Rules for Ships for Liquefied Gases. Any acceptance of manufacturer's certification in other Sections of this Chapter is not applicable to the valves fitted to pressure vessels in *18, Ch 10 Electrical Installations* and *11* of the Rules for Ships for Liquefied Gases.

9.7.4 Any valve fitted directly onto a pressure vessel is to be considered a mounting and is required to be hydraulically pressure tested to twice the approved design pressure. See *Pt 5, Ch 11, 10.2 Mountings 10.2.1*.

9.8 Expansion bellows

9.8.1 The following plans and particulars are to be submitted:

- (a) Dimensioned drawings of each type of bellows.
- (b) Design calculations to show that the bellows are suitable for the intended design conditions, carried out to EJMA (Expansion Joint Manufacturers Association) standards (latest edition) or equivalent.
- (c) A proposed type test program covering the tests detailed in *Process Pressure Vessels and Liquid, Vapour and Pressure Piping Systems* of the Rules for Ships for Liquefied Gases.
- (d) Calculations to EJMA standards may be accepted, together with sample testing detailed above, in order to cover the entire size range for the type.

9.8.2 In accordance with 5.3 of the Rules for Ships for Liquefied Gases, the requirements for type testing in *Pt 5, Ch 12, 9.8 Expansion bellows 9.8.3* are to be performed on each type of expansion bellows intended for use on LPG/LNG piping.

9.8.3 For each type of expansion bellows, an element of the bellows, not pre-compressed, is to be pressure tested at not less than five times the design pressure without bursting. This test is to be conducted at room temperature on each 'type' of element and need not be the complete bellows unit. A test on one element can cover other sized bellows with the same cross-sectional bellows form. The design pressure is to be at least 1 MPa gauge; bellows fitted to safety valves and vent lines may have a minimum design pressure of not less than the lower of 0,5 MPa gauge or 10 times the relief valve set pressure in accordance with *Process Pressure Vessels and Liquid, Vapour and Pressure Piping Systems* of the Rules for Ships for Liquefied Gases. The required test duration is not to be less than 5 minutes.

9.8.4 A pressure test is to be performed on each type of expansion joint complete with all the accessories such as flanges, stays and articulations, at twice the design pressure at the extreme displacement conditions recommended by the manufacturer without permanent deformation. The test is to be undertaken at the minimum design temperature, unless the bellows material is stainless steel for which this test may be carried out at ambient temperature. The test duration is to be 30 minutes unless otherwise agreed with LR.

9.8.5 A cyclic thermal movement test, replicating the cooling down and warming up cycle which occurs during cargo loading and discharge, is to be performed on a complete expansion joint, by the application of representative external deflection resulting in bellow movement. This is to successfully withstand at least as many cycles, under the conditions of pressure, temperature, axial movement, rotational movement and transverse movement, as it will encounter in actual service. The number of cycles is to be estimated by the builder and depends on the ship's intended trading pattern and life expectancy. As a minimum, testing to 7000 cycles is to be carried out. The test is to be carried out at between 2-5 cycles per second. Testing at ambient temperature is permitted when this testing is at least as severe as testing at the service temperature. The maximum movements on the horizontal and vertical axis are to be provided by the builders and obtained from their stress analysis; however, the test can be extended to any value which is greater than that expected, or to the maximum deflection for which the bellows unit is suitable. Movements in the test need not be in both horizontal and vertical directions; but the horizontal-vertical box diagonal distance may be used. NDE testing is required after cyclic testing.

9.8.6 A cyclic fatigue test, representing ship deformation, is to be performed on a complete expansion joint, without internal pressure, by simulating the bellows movement corresponding to a compensated pipe length, for at least 2,000,000 cycles at a frequency not higher than 5 Hz. NDE is required after cyclic testing. This test is only required when, due to the piping arrangement, ship deformation loads are actually experienced.

9.9 Pressure testing of piping and other piping components

9.9.1 Pressure testing is to be undertaken in accordance with specific Rule requirements relating to the system in which the component is to be located.

9.9.2 The duration for which pressure tests are to be held is to be in conjunction with an applicable and recognised code or standard acceptable to LR.

9.10 Equipment documentation

9.10.1 A certificate is required for each piping component supplied to be fitted in a Class I or Class II system. This certification is required for each size and type of equipment delivered. A single certificate may cover a number of valves, provided that they are of the same type and size, and serial numbers have been included on the certificate. If the piping components are part of a system fitted to a skid or packaged unit, then the complete skid may be supplied with a single certificate stating that the package has been constructed using approved materials, approved and tested in accordance with LR Rule requirements.

9.11 Relief valves for LPG/LNG cargo and deck tanks

9.11.1 Relief valves fitted to cargo tanks and deck tanks are to be of a type tested design. Type testing is to include:

- flow or capacity verification to a recognised Standard acceptable to the Administration;
- cryogenic testing when operating at design temperatures colder than minus 55°C;
- seat tightness testing to a recognised Standard or manufacturers' procedure acceptable to the Administration; and
- pressure testing of pressure-containing parts to at least 1,5 times the design pressure.

9.11.2 The materials used for construction of relief valves fitted to cargo tanks and deck tanks are to be produced in a works approved by LR and be provided with a Lloyd's Register Material Certificate.

■ Section 10 Austenitic stainless steels

10.1 Pipe thickness

10.1.1 The minimum thickness of austenitic stainless steel pipes is to be determined from the formula given in *Pt 5, Ch 12, 2.2 Wrought steel pipes and bends 2.2.1* and either *Pt 5, Ch 12, 2.2 Wrought steel pipes and bends 2.2.3* or *Pt 5, Ch 12, 2.2 Wrought steel pipes and bends 2.2.4* using a corrosion allowance of 0,8 mm. Values of 1,0 per cent proof stress and tensile strength of the material for use in the formula in *Pt 5, Ch 12, 2.2 Wrought steel pipes and bends 2.2.1* may be obtained from *Table 6.5.2 Mechanical properties for acceptance purposes* in *Ch 6 Steel Pipes and Tubes* of the Rules for Materials.

10.1.2 Where stainless steel is used in lubricating oil, hydraulic oil and refrigeration systems, the corrosion allowance may be reduced to 0 mm. For pipes passing through tanks, an additional corrosion allowance is to be added to take account of external

corrosion; the addition will depend on the external medium and the value is to be in accordance with *Table 12.2.3 Values of c for steel pipes*. Where the pipes are efficiently protected, the corrosion allowance may be reduced by not more than 50 per cent.

10.1.3 In no case is the thickness of austenitic stainless steel pipes to be less than that shown in *Table 12.10.1 Minimum thickness for austenitic stainless steel pipes*.

Table 12.10.1 Minimum thickness for austenitic stainless steel pipes

Standard pipe sizes (outside diameter) in mm	Min. thickness in mm
8,0 to 10,0	0,8
10,2 to 17,2	1,0
21,3 to 48,3	1,6
60,3 to 88,9	2,0
114,3 to 168,3	2,3
219,1	2,6
273,0	2,9
323,9 to 406,4	3,6
over 406,4	4,0

Note: Diameters and thicknesses according to national or international standards may be accepted.

■ Section 11

Appendix - Guidance notes on metal pipes for water services

11.1 General

11.1.1 These guidance notes, except where it is specifically stated, apply to sea-water piping systems.

11.1.2 In addition to the selection of suitable materials, careful attention should be given to the design details of the piping system and the workmanship in fabrication, construction and installation of the pipework in order to obtain maximum life in service.

11.2 Materials

11.2.1 Materials used in sea-water piping systems include:

- Galvanised steel.
- Steel pipes lined with rubber, plastics or stoved coatings.
- Copper.
- 90/10 copper-nickel-iron.
- 70/30 copper-nickel.
- Aluminium brass.

11.2.2 Selection of materials should be based on:

- the ability to resist general and localised corrosion, such as pitting, impingement attack and cavitation throughout all the flow velocities likely to be encountered;
- compatibility with the other materials in the system, such as valve bodies and casings, (e.g. in order to minimise bimetallic corrosion);
- the ability to resist selective corrosion, e.g. dezincification of brass, dealuminification of aluminium brass and graphitisation of cast iron;

- the ability to resist stress corrosion and corrosion fatigue; and
- the amenability to fabrication by normal practices.

11.3 Steel pipes

11.3.1 Steel pipes should be protected against corrosion, and protective coatings should be applied on completion of all fabrication, i.e. bending, forming and welding of the steel pipes.

11.3.2 Welds should be free from lack of fusion and crevices. The surfaces should be dressed to remove slag and spatter and this should be done before coating. The coating should be continuous around the ends of the pipes and on the faces of flanges.

11.3.3 Galvanising the bores and flanges of steel pipes as protection against corrosion is common practice, and is recommended as the minimum protection for pipes in sea-water systems, including those for bilge and ballast service.

11.3.4 Austenitic stainless steel pipes are not recommended for salt-water services as they are prone to pitting, particularly in polluted waters.

11.3.5 Rubber lined pipes are effective against corrosion and suitable for higher water velocities. The rubber lining should be free from defects, e.g. discontinuities, pinholes, etc. and it is essential that the bonding of the rubber to the bore of the pipe and flange face is sound. Rubber linings should be applied by firms specialising in this form of protection.

11.3.6 The foregoing comments on rubber lined pipes also apply to pipes lined with plastics.

11.3.7 Stove coating of pipes as protection against corrosion should only be used where the pipes will be efficiently protected against mechanical damage.

11.4 Copper and copper alloy pipes

11.4.1 Copper pipes are particularly susceptible to perforation by corrosion/erosion and should only be used for low water velocities and where there is no excessive local turbulence.

11.4.2 Aluminium brass and copper-nickel-iron alloy pipes give good service in reasonably clean sea-water. For service with polluted river or harbour waters, copper-nickel-iron alloy pipes with at least 10 per cent nickel are preferable. Alpha-brasses, i.e. those containing 70 per cent or more copper, must be inhibited effectively against dezincification by suitable additions to the composition. Alpha beta-brasses, (i.e. those containing less than 70 per cent copper), should not be used for pipes and fittings.

11.4.3 New copper alloy pipes should not be exposed initially to polluted water. Clean sea-water should be used at first to allow the metals to develop protective films. If this is not available the system should be filled with inhibited town mains water.

11.5 Flanges

11.5.1 Where pipes are exposed to sea-water on both external and internal surfaces, flanges should be made, preferably, of the same material. Where sea-water is confined to the bores of pipes, flanges may be of the same material or of less noble metal than that of the pipe, *see also Pt 5, Ch 12, 2.3 Pipe joints - General*.

11.5.2 Fixed or loose type flanges may be used. The fixed flanges should be attached to the pipes by fillet welds or by capillary silver brazing. Where welding is used, the fillet weld at the back should be a strength weld and that in the face, a seal weld.

11.5.3 Inert gas shielded arc welding is the preferred process but metal arc welding may be used on copper-nickel-iron alloy pipes.

11.5.4 Mild steel flanges may be attached by argon arc welding to copper-nickel-iron pipes and give satisfactory service, provided that no part of the steel is exposed to the sea-water.

11.5.5 Where silver brazing is used, strength should be obtained by means of the bond in a capillary space over the whole area of the mating surfaces. A fillet braze at the back of the flange or at the face is undesirable. The alloy used for silver brazing should contain not less than 49 per cent silver.

11.5.6 The use of a copper-zinc brazing alloy is not permitted.

11.6 Water velocity

11.6.1 Water velocities should be carefully assessed at the design stage and the materials of pipes, valves, etc. selected to suit the conditions.

11.6.2 The water velocity in copper pipes should not exceed 1 m/s.

Section

- 1 **General requirements**
- 2 **Construction and installation**
 - Cross-reference**
- 3 **Drainage of compartments, other than machinery spaces**
- 4 **Bilge drainage of machinery spaces**
- 5 **Sizes of bilge suction pipes**
- 6 **Pumps on bilge service and their connections**
- 7 **Piping systems and their fittings**
- 8 **Additional requirements for bilge drainage and cross-flooding arrangements for passenger ships**
- 9 **Additional requirements relating to fixed pressure water spray fire-extinguishing systems**
- 10 **Drainage arrangements for ships not fitted with propelling machinery**
- 11 **Ballast system**
- 12 **Air, overflow and sounding pipes**
 - Cross-references**
- 13 **Additional requirements for drainage and pumping arrangements for bulk carriers**
- 14 **Water ingress detection arrangements**

■ *Section 1* **General requirements**

1.1 Application

1.1.1 The requirements of this Chapter apply to piping systems on all types of ship except where otherwise stated.

1.1.2 Whilst the requirements satisfy the relevant regulations of the SOLAS - *International Convention for the Safety of Life at Sea*, and applicable amendments, attention should be given to any relevant regulations of the MARPOL - *International Convention for the Prevention of Pollution from Ships*, and applicable amendments, where these impact the design or construction of piping systems. Attention should also be given to any relevant statutory requirements of the National Authority of the country in which the ship is to be registered.

1.1.3 Consideration will be given to special cases or to arrangements which are equivalent to those required by these Rules. Consideration will also be given to the pumping arrangements of small ships and ships to be assigned class notations for restricted or special services.

1.1.4 Piping design is to comply with *Pt 5, Ch 12 Piping Design Requirements* as applicable.

1.2 Prevention of progressive flooding in damage condition

1.2.1 For ships to which subdivision and damage stability requirements apply, precautions are to be taken to prevent progressive flooding between compartments resulting from damage to piping systems. For this purpose, piping systems are to be located inboard of the assumed extent of damage applicable to the ship type.

1.2.2 Where it is not practicable to locate piping systems as required by *Pt 5, Ch 13, 1.2 Prevention of progressive flooding in damage condition 1.2.1*, the following precautions are to be taken:

- (a) Bilge suction pipes are to be provided with non-return valves of approved type.

- (b) Other piping systems are to be provided with shut-off valves capable of being operated from positions accessible in the damage condition, or from above the bulkhead deck where required by the Rules.

These valves are to be located in the compartment containing the open end or in a suitable position such that the compartment may be isolated in the event of damage to the piping system.

1.2.3 Where subdivision and damage stability requirements apply and where penetration of watertight divisions by pipes, ducts, trunks or other penetrations is necessary, arrangements are to be made to maintain the watertight integrity.

1.3 Plans and particulars

1.3.1 The following plans (in diagrammatic form) and particulars are to be submitted for approval. Additional plans should not be submitted unless the arrangements are of a novel or special character affecting classification:

- (a) Arrangements of air pipes and closing devices for all tanks and enclosed spaces.
- (b) Sounding arrangements for all tanks, enclosed spaces and cargo holds.
- (c) Arrangements of level alarms fitted in tanks, cargo holds, machinery spaces, pump rooms and any other spaces.
- (d) Arrangements of any cross flooding or heeling tank systems.
- (e) Bilge drainage arrangements for all compartments which are to include details of location, number and capacity of pumping units on bilge service. In the case of passenger ships, the bilge pump numeral, as defined in the *SOLAS - International Convention for the Safety of Life at Sea*, and applicable amendments are to be stated, together with the number of flooded compartments which the ship is required to withstand under damage conditions.
- (f) Ballast filling and drainage arrangements: a schematic piping drawing showing connection of the ballast water treatment system to the ballast filling and drainage arrangement is to be submitted.
- (g) Fuel oil filling, transfer, relief and spill/drainage arrangements.
- (h) Tank overflow arrangements.
- (i) Blanking arrangements for bilge and ballast piping systems for bulk carriers having floodable holds.
- (j) Isolation arrangements for bilge systems where cargo holds are intended for the carriage of dangerous goods.
- (k) Details verifying compliance with the sizing of air pipes required by *Pt 5, Ch 13, 12.8 Size of air pipes*.
- (l) Arrangements of fuel oil piping in connection with oil burning installations and oil fired galleys.
- (m) Arrangements of fuel oil burning units for boilers and thermal fluid heaters.
- (n) Arrangement of boiler feed system.
- (o) Arrangements of thermal fluid circulation systems.
- (p) Arrangement of compressed air systems for main and auxiliary services.
- (q) Arrangements of lubricating oil systems.
- (r) Arrangements of flammable liquids used for control and heating systems.
- (s) Arrangements of power transmission systems for services essential for safety or for the operation of the ship at sea.
- (t) Arrangements of cooling water systems for main and auxiliary services.
- (u) Fuel oil settling service and other fuel oil tanks not forming part of the ship's structure and lubricating and hydraulic oil tanks with a capacity of 500 litres or more, not forming part of the ship's structure.
- (v) Arrangements and dimensions of all steam pipes where the design pressure or temperature exceeds 16,0 bar (16,3 kgf/cm²) or 300°C, respectively, and the outside diameter exceeds 76,1 mm, with details of flanges, bolts and weld attachments, and particulars of the material of pipes, flanges, bolts and electrodes.
- (w) Details verifying compliance with the capacity of the fuel oil treatment plant required by *Pt 5, Ch 14, 3.9 Fuel oil treatment for supply to main and auxiliary oil engines and gas turbines 3.9.1*.
- (x) Details verifying compliance of demands on low pressure air systems by supplying essential services as required by *Pt 5, Ch 14, 10.1 General 10.1.3*.
- (y) For water ingress detection arrangements, see *Pt 5, Ch 13, 14 Water ingress detection arrangements*, plans and information in accordance with *Pt 6, Ch 1, 1.2 Documentation required for design review* and, additionally, general arrangement plans showing the spaces provided with water ingress detectors, installed equipment locations and cable routes. Details of National Administration approvals are to be included.

■ Section 2**Construction and installation****2.1 Materials**

2.1.1 Except where otherwise stated in this Chapter, pipes, valves and fittings are to be made of steel, cast iron, copper, copper alloy, or other approved material suitable for the intended service.

2.1.2 Where applicable, the materials are to comply with the relevant requirements of *Pt 5, Ch 12 Piping Design Requirements*.

2.1.3 Materials sensitive to heat, such as aluminium, lead or plastics, are not to be used in systems essential to the safe operation of the ship, or for containing combustible liquids or sea-water where leakage or failure could result in fire or in the flooding of watertight compartments, see *Pt 5, Ch 12 Piping Design Requirements* for plastics pipes.

2.1.4 Aluminium alloy pipes are not acceptable for fire extinguishing pipes unless they are suitably protected against the effect of heat. The proposed use of aluminium alloy with appropriate insulation will be considered when it has been demonstrated that the arrangements provide equivalent structural and integrity properties compared to steel. In open and exposed locations where the insulation material is likely to suffer from mechanical damage suitable protection is to be provided.

2.2 Pipe wall thickness

2.2.1 The minimum nominal wall thickness of steel, copper and copper alloy pipes are to be in accordance with *Pt 5, Ch 12 Piping Design Requirements*.

2.2.2 Special consideration will be given to the wall thicknesses of pipes made of materials other than steel, copper and copper alloy.

2.3 Valves – Installation and control

2.3.1 Valves and cocks are to be fitted in places where they are at all times readily accessible, unless otherwise specifically mentioned in the Rules. Valves in cargo oil and ballast systems may be fitted inside tanks, subject to *Pt 5, Ch 13, 2.3 Valves – Installation and control 2.3.2*.

2.3.2 All valves which are provided with remote control are to be arranged for local manual operation, independent of the remote operating mechanism. For shipside valves and valves on the collision bulkhead, the means for local manual operation are to be permanently attached. For submerged valves in cargo oil and ballast systems, as permitted by *Pt 5, Ch 13, 2.3 Valves – Installation and control 2.3.1*, local manual operation may be by extended spindle or a portable hand pump. Where manual operation is by hand pump, the control lines to each submerged valve are to incorporate quick coupling connections, as close to the valve actuator as practicable, to allow easy connection of the hand pump. Not less than two hand pumps are to be provided.

2.3.3 In case of valves which are required by the Rules to be provided with remote control, opening and/or closing of the valves by local manual means is not to render the remote control system inoperable.

2.4 Attachment of valves to watertight plating

2.4.1 Valve chests, cocks, pipes or other fittings attached direct to the plating of tanks, and to bulkheads, flats or tunnels which are required to be of watertight construction, are to be secured by means of studs screwed through the plating or by tap bolts, and not by bolts passing through clearance holes. Alternatively, the studs or the bulkhead piece may be welded to the plating.

2.4.2 For requirements relating to valves on the collision bulkhead, see *Pt 5, Ch 13, 3.5 Fore and after peaks 3.5.4*.

2.5 Ship-side valves and fittings (other than those on scuppers and sanitary discharges)

2.5.1 All sea inlet and overboard discharge pipes are to be fitted with valves or cocks secured direct to the shell plating, or to the plating of fabricated steel water boxes attached to the shell plating. These fittings are to be secured by bolts tapped into the plating and fitted with countersunk heads, or by studs screwed into heavy steel pads fitted to the plating. The stud holes are not to penetrate the plating.

2.5.2 Valves for ship-side applications are to be installed such that the section of piping immediately inboard of the valve can be removed without affecting the watertight integrity of the hull.

2.5.3 Distance pieces of short, rigid construction, and made of approved material, may be fitted between the valves and shell plating. Distance pieces of steel may be welded to the shell plating. Details of the welded connections and of fabricated steel water boxes are to be submitted.

2.5.4 Gratings are to be fitted at all openings in the ship's side for sea inlet valves and inlet water boxes. The net area through the gratings is to be not less than twice that of the valves connected to the sea inlets, and provision is to be made for clearing the gratings by use of low pressure steam or compressed air, see *Pt 5, Ch 13, 2.5 Ship-side valves and fittings (other than those on scuppers and sanitary discharges) 2.5.9.*

2.5.5 All suction and discharge valves and cocks secured direct to the shell plating of the ship are to be fitted with spigots passing through the plating, but the spigots on the valves or cocks may be omitted if these fittings are attached to pads or distance pieces which themselves form spigots in way of the shell plating. Blow-down valves or cocks are also to be fitted with a protection ring through which the spigot is to pass, the ring being on the outside of the shell plating. Where alternative forms of attachment are proposed, details are to be submitted for consideration.

2.5.6 Blow-down valves or cocks on the ship's side are to be fitted in accessible positions above the level of the working platform, and are to be provided with indicators showing whether they are open or shut. Cock handles are not to be capable of being removed unless the cocks are shut, and, if valves are fitted, the hand wheels are to be suitably retained on the spindle.

2.5.7 Sea inlet and overboard discharge valves and cocks are in all cases to be fitted in easily accessible positions and, so far as practicable, are to be readily visible. Indicators are to be provided local to the valves and cocks, showing whether they are open or shut. Provision is to be made for preventing any discharge of water into lifeboats. The valve spindles are to extend above the lower platform, and the hand wheels of the main cooling water sea inlet and emergency bilge suction valves are to be situated not less than 460 mm above this platform.

2.5.8 Ship-side valves and fittings, if made of steel or other approved material with low corrosion resistance, are to be suitably protected against wastage.

2.5.9 The scantlings of valves and valve stools fitted with steam or compressed air clearing connections are to be suitable for the maximum pressure to which the valves and stools may be subjected.

2.5.10 Valves, cocks and distance pieces, intended for installation on the ship's side below the load waterline, are to be tested by hydraulic pressure to not less than 5 bar.

2.5.11 For sea connections for ships having notation for ice navigation, see *Pt 8, Ch 2, 3.3 Ship-side valves, Pt 8, Ch 2, 3.5 Main propulsion and essential auxiliary engines* and *Pt 8, Ch 2, 11.21 Sea inlets and cooling water systems.*

2.6 Piping systems – Installation

2.6.1 Bilge, ballast and cooling water suction and discharge pipes are to be permanent pipes made in readily removable lengths with flanged joints, except as mentioned in *Pt 5, Ch 13, 7.10 Bilge pipes in way of deep tanks*, and are to be efficiently secured in position to prevent chafing or lateral movement. For joints in fuel oil piping systems, see *Pt 5, Ch 14, 4.5 Pipes conveying oil* and *Pt 5, Ch 14, 4.6 Low pressure pipes.*

2.6.2 Where lack of space prevents the use of normal circular flanges, details of the alternative methods of joining the pipes are to be submitted.

2.6.3 Long or heavy lengths of pipes are to be supported by bearers so that no undue load is carried by the flanged connections of the pumps or fittings to which they are attached.

2.7 Provision for expansion

2.7.1 Suitable provision for expansion is to be made, where necessary, in each range of pipes.

2.7.2 Where expansion pieces are fitted, they are to be of an approved type and are to be protected against over extension and compression. The adjoining pipes are to be suitably aligned, supported, guided and anchored. Where necessary, expansion pieces of the bellows type are to be protected against mechanical damage.

2.7.3 Expansion pieces of an approved type incorporating special quality oil resistant rubber or other suitable synthetic material may be used in cooling water lines in machinery spaces. Where fitted in sea-water lines, they are to be provided with guards which will effectively enclose, but not interfere with, the action of the expansion pieces and will reduce to the minimum practicable any flow of water into the machinery spaces in the event of failure of the flexible elements. Proposals to use such fittings in water lines for other services, including:

- ballast lines in machinery spaces, in duct keels and inside double bottom water ballast tanks, and

- bilge lines inside duct keels only,

will be specially considered when plans of the pumping systems are submitted for approval.

2.7.4 For requirements relating to flexible hoses, see *Pt 5, Ch 12 Piping Design Requirements*.

2.8 Piping in way of refrigerated chambers

2.8.1 All pipes, including scupper pipes, air pipes and sounding pipes which pass through chambers intended for the carriage or storage of refrigerated produce are to be well insulated.

2.8.2 Where the pipes referred to in *Pt 5, Ch 13, 2.8 Piping in way of refrigerated chambers 2.8.1* pass through chambers intended for temperatures of 0°C or below, they are also to be insulated from the steel structure, except in positions where the temperature of the structure is mainly controlled by the external temperature and will normally be above freezing point. Pipes passing through a deckplate within the ship side insulation, where the deck is fully insulated below and has an insulation ribband on top, are to be attached to the deck plating. In the case of pipes adjacent to the shell plating, metallic contact between the pipes and the shell plating or frames is to be arranged so far as practicable.

2.8.3 The air refreshing pipes to and from refrigerated compartments need not, however, be insulated from the steel work.

2.9 Miscellaneous requirements

2.9.1 All pipes situated in cargo spaces, fish holds, chain lockers or other positions where they are liable to mechanical damage are to be efficiently protected.

2.9.2 Wash deck pipes and discharge pipes from the pumps to domestic water tanks are not to be led through cargo holds. Any proposed departure from this requirement is to be submitted for consideration.

2.9.3 So far as practicable, pipelines, including exhaust pipes from oil engines, are not to be led in the vicinity of switchboards or other electrical appliances in positions where the drip or escape of liquid, gas or steam from joints or fittings could cause damage to the electrical installation. Where it is not practicable to comply with these requirements, drip trays or shields are to be provided as found necessary. Short sounding pipes to tanks are not to terminate near electrical appliances, see *Pt 5, Ch 13, 12.13 Short sounding pipes 12.13.2*.

2.10 Testing after installation

2.10.1 After installation on board, all steam, hydraulic, compressed air and other piping systems covered by *Pt 5, Ch 13, 1.3 Plans and particulars 1.3.1*, together with associated fittings which are under internal pressure, are to be subjected to a running test at the intended maximum working pressure.

■ Cross-reference

For guidance on metal pipes for water services, see *Pt 5, Ch 12, 11 Appendix - Guidance notes on metal pipes for water services*.

■ Section 3 Drainage of compartments, other than machinery spaces

3.1 General

3.1.1 All ships are to be provided with efficient pumping plant having the suctions and means for drainage so arranged that any water within any compartment of the ship, or any watertight section of any compartment, can be pumped out through at least one suction when the ship is on an even keel and is either upright or has a list of not more than 5°. For this purpose, wing suctions will generally be necessary, except in short, narrow compartments where one suction can provide effective drainage under the above conditions.

3.1.2 In passenger ships, the pumping plant is to be capable of draining any watertight compartment under all practicable conditions after a casualty, whether the ship is upright or listed.

3.1.3 In the case of dry compartments, the suctions required by *Pt 5, Ch 13, 3.1 General 3.1.1* are, except where otherwise stated, to be branch bilge suctions, i.e. suctions connected to a main bilge line.

3.1.4 For drainage arrangements of non-self-propelled ships, see *Pt 5, Ch 13, 10 Drainage arrangements for ships not fitted with propelling machinery*.

3.1.5 For additional drainage arrangements on ferries and Roll on-Roll off ships, see *Pt 4, Ch 2, 9.9 Watertightness and drainage*.

3.1.6 For a normally inaccessible small void compartment such as an echo sounding compartment, which is accessed from within a normally inaccessible space such as a forepeak tank, alternative drainage arrangements to those required by *Pt 5, Ch 13, 3.1 General 3.1.1* may be considered. For such arrangements, a warning notice is to be located in a prominent position specifying the precautions to be taken prior opening the manhole of the small void compartment. Means are to be provided to indicate flooding of the compartment without opening, such as fitting indicator plugs to the manhole. Drainage arrangements are to be submitted to LR for approval.

3.2 Cargo holds

3.2.1 In ships having only one hold, and this over 30 m in length, bilge suctions are to be fitted in suitable positions in the fore and after sections of the hold.

3.2.2 Where close ceiling or continuous gusset plates are fitted over the bilges, arrangements are to be made whereby water in a hold compartment may find its way to the suction pipes.

3.2.3 Where the inner bottom plating extends to the ship's side, the bilge suctions are to be led to wells placed at the wings. If the tank top plating has inverse camber, a well is also to be fitted at the centreline, but in the case of trawlers and fishing vessels, a single well fitted at the centre may be accepted. For capacity and construction of bilge wells, see *Pt 5, Ch 13, 7.6 Bilge wells*.

3.2.4 For drainage arrangements from refrigerated cargo spaces, see *Pt 6, Ch 3, 4.19 Drainage from refrigerated spaces*.

3.2.5 For cargo holds having non-weather-tight hatch covers or where hatch covers have been omitted, drainage arrangements are to take into account the effects of additional water ingress into the hold(s). High level bilge alarms are to be provided in cargo holds having non-weather-tight hatch covers or where hatch covers have been omitted, see also *Pt 4, Ch 8, 11 Hatch covers*.

3.2.6 Drainage arrangements of cargo holds intended for the carriage of flammable or toxic liquids are to be designed to prevent inadvertent drainage of such products through machinery space piping systems.

3.3 Holds and deep tanks for alternative carriage of liquid or dry cargo

3.3.1 Where holds and deep tanks are intended for the alternative carriage of liquid or dry cargo, the drainage arrangements are to be in accordance with the following:

- (a) For dry cargoes, *Pt 5, Ch 13, 3.1 General* and *Pt 5, Ch 13, 3.2 Cargo holds*.
- (b) For water ballast, fuel oil or cargo oil having a flash point of 60°C or above, *Pt 5, Ch 13, 3.4 Tanks and cofferdams*.
- (c) For cargo oil having a flash point below 60°C, *Pt 5, Ch 15 Piping Systems for Oil Tankers*.

3.3.2 For blanking arrangements of filling and suction pipes, see *Pt 5, Ch 13, 7.12 Blanking arrangements*.

3.4 Tanks and cofferdams

3.4.1 All tanks (including double bottom tanks), whether used for water ballast, fuel oil or liquid cargoes, are to be provided with suction pipes, led to suitable power pumps, from the after end of each tank.

3.4.2 In general, the drainage arrangements are to be in accordance with *Pt 5, Ch 13, 3.1 General*. However, where the tanks are divided by longitudinal watertight bulkheads or girders into two or more tanks, a single suction pipe, led to the after end of each tank, will normally be acceptable.

3.4.3 Similar drainage arrangements are to be provided for cofferdams, except that the suctions may be led to the main bilge line.

3.4.4 The pumping arrangements for tanks that are intended to carry cargo oil having a flash point of 60°C or above, are also to comply with the requirements of *Pt 5, Ch 14, 2 Fuel oil - General requirements*, *Pt 5, Ch 14, 3 Fuel oil burning arrangements* and *Pt 5, Ch 14, 4 Fuel oil pumps, pipes, fittings, tanks, etc.*, as far as they are applicable.

3.5 Fore and after peaks

3.5.1 Fuel oil, lubrication oil and other flammable liquids are not to be carried in forepeak tanks.

3.5.2 Where the peaks are used as tanks, a power pump suction is to be led to each tank, except in the case of small tanks used for the carriage of domestic fresh water, where hand pumps may be used.

3.5.3 Where the peaks are not used as tanks, and main bilge line suction is not fitted, drainage of both peaks may be effected by hand pump suction, provided that the suction lift is well within the capacity of the pumps and in no case exceeds 7,3 m. In the case of trawlers and fishing vessels, drainage of the after peak may be effected by means of a self-closing cock fitted in a well lighted and readily accessible position.

3.5.4 Except as permitted by *Pt 5, Ch 13, 3.5 Fore and after peaks 3.5.5*, the collision bulkhead is not to be pierced below the bulkhead deck by more than one pipe for dealing with the contents of the fore peak. The pipe is to be provided with a screw-down valve capable of being operated from an accessible position above the bulkhead deck, the chest being secured to the bulkhead inside the fore peak. An indicator is to be provided to show whether the valve is open or closed. The valves may be fitted on the after side of the collision bulkhead, provided that the valve is readily accessible under all service conditions and the space in which it is located is not a cargo space.

3.5.5 Where the fore peak is divided into two compartments, the collision bulkhead may be pierced below the bulkhead deck by two pipes (i.e. one for each compartment) provided there is no practical alternative to the fitting of a second pipe. Each pipe is to be provided with a screw-down valve, fitted and controlled as in *Pt 5, Ch 13, 3.5 Fore and after peaks 3.5.4*.

3.6 Spaces above fore peaks, after peaks and machinery spaces

3.6.1 Provision is to be made for the drainage of the chain locker and watertight compartments above the fore peak tank by hand or power pump suction.

3.6.2 Steering gear compartments or other small enclosed spaces situated above the after peak tank are to be provided with suitable means of drainage, either by hand or power pump bilge suction.

3.6.3 Subject to special approval of any applicable subdivision requirements, compartments referred to in *Pt 5, Ch 13, 3.6 Spaces above fore peaks, after peaks and machinery spaces 3.6.2* that are adequately isolated from the adjacent 'tween decks, may be drained by scuppers of not less than 38 mm bore, discharging to the tunnel (or machinery space in the case of ships with machinery aft) and fitted with self-closing cocks situated in well lighted and visible positions.

3.6.4 In case of trawlers and fishing vessels, accommodation spaces which overhang the machinery space, may also be drained as in *Pt 5, Ch 13, 3.6 Spaces above fore peaks, after peaks and machinery spaces 3.6.3*.

3.6.5 For drainage of the fore and after peaks, see *Pt 5, Ch 13, 3.5 Fore and after peaks*.

3.7 Maintenance of integrity of bulkheads

3.7.1 The intactness of the machinery space bulkheads, and of tunnel plating required to be of watertight construction, is not to be impaired by the fitting of scuppers discharging to machinery space or tunnels from adjacent compartments which are situated below the bulkhead deck. These scuppers may, however, be led into a strongly constructed scupper drain tank situated in the machinery space or tunnel, but closed to these spaces and drained by means of a suction of appropriate size led from the main bilge line through a screw-down non-return valve.

3.7.2 The scupper tank air pipe is to be led to above the bulkhead deck, and provision is to be made for ascertaining the level of water in the tank.

3.7.3 Where one tank is used for the drainage of several watertight compartments, the scupper pipes are to be provided with screw-down non-return valves.

3.7.4 No drain valve or cock is to be fitted to the collision bulkhead. Drain valves or cocks are not to be fitted to other watertight bulkheads if alternative means of drainage are practicable.

3.7.5 Where drain valves or cocks are fitted to bulkheads other than the collision bulkhead, as permitted by *Pt 5, Ch 13, 3.7 Maintenance of integrity of bulkheads 3.7.4*, the drain valves or cocks are to be at all times readily accessible and are to be capable of being shut off from positions above the bulkhead deck. Indicators are to be provided to show whether the drains are open or shut. These arrangements are not permissible in passenger ships.

3.7.6 Bilge drain valves or cocks may be used for draining accommodation spaces and the after dry peak of trawlers and fishing vessels as stated in *Pt 5, Ch 13, 3.6 Spaces above fore peaks, after peaks and machinery spaces 3.6.4* and *Pt 5, Ch 13, 3.5 Fore and after peaks 3.5.3*.

3.7.7 For drainage of stern compartment, see *Pt 5, Ch 13, 3.6 Spaces above fore peaks, after peaks and machinery spaces*.

■ Section 4 Bilge drainage of machinery spaces

4.1 General

4.1.1 The bilge drainage arrangements in the machinery space are to comply with *Pt 5, Ch 13, 3.1 General*, except that the arrangements are to be such that any water which may enter this compartment can be pumped out through at least two bilge suction when the ship is on an even keel, and is either upright or has a list of not more than 5°. One of these suction is to be a branch bilge suction, i.e. a suction connected to the main bilge line, and the other is to be a direct bilge suction, i.e. a suction led direct to an independent power pump. Examples of the necessary arrangements are detailed in *Pt 5, Ch 13, 4.2 Machinery space with double bottom* and *Pt 5, Ch 13, 4.3 Machinery space without double bottom*.

4.1.2 In passenger ships, the drainage arrangements are to be such that machinery spaces can be pumped out under all practical conditions after a casualty, whether the ship is upright or listed.

4.2 Machinery space with double bottom

4.2.1 Where the double bottom extends the full length of the machinery space and forms bilges at the wings, it will be necessary to provide one branch and one direct bilge suction at each side.

4.2.2 Where the double bottom plating extends the full length and breadth of the compartment, one branch bilge suction and one direct bilge suction are to be led to each of two bilge wells, situated one at each side.

4.2.3 For capacity and construction of bilge wells, see *Pt 5, Ch 13, 7.6 Bilge wells*.

4.3 Machinery space without double bottom

4.3.1 Where there is no double bottom and the rise of floor is not less than 5°, one branch and one direct bilge suction are to be led to accessible positions as near the centreline as practicable.

4.3.2 In ships where the rise of floor is less than 5°, and in all passenger ships, additional bilge suction are to be provided at the wings.

4.4 Additional bilge suction

4.4.1 Additional bilge suction may be required for the drainage of depressions in the tank top formed by crankpits, or other recesses, by tank tops having inverse camber or by discontinuity of the double bottom.

4.4.2 In ships in which the propelling machinery is situated at the after end of the ship, it will generally be necessary for bilge suction to be fitted in the forward wings as well as in the after end of the machinery space, but each case will be dealt with according to the size and structural arrangements of the compartment.

4.4.3 In ships propelled by electrical machinery, special means are to be provided to prevent the accumulation of bilge water under the main propulsion generators and motors.

4.5 Separate machinery spaces

4.5.1 Where the machinery space is divided by watertight bulkheads to separate the boiler room(s), or auxiliary engine room(s) from the main engine room, the number and position of the branch bilge suction in the boiler room(s) or auxiliary engine room(s) are to be the same as for cargo holds.

4.5.2 In addition to the branch bilge suction, required by *Pt 5, Ch 13, 4.5 Separate machinery spaces 4.5.1*, at least one independent power pump direct bilge suction is to be fitted in each compartment. Similar provision is to be made in separate motor rooms of electrically propelled ships.

4.5.3 In passenger ships, each independent bilge pump is to have a direct bilge suction from the space in which it is situated, but not more than two such suction are required in any one space. Where two or more such suction are provided, there is to be at least one suction on each side of the space.

4.6 Machinery space – Emergency bilge drainage

4.6.1 In addition to the bilge suctions detailed in *Pt 5, Ch 13, 4.1 General*, an emergency bilge suction is to be provided in each main machinery space. This suction is to be led to the main cooling water pump from a suitable low level in the machinery space and is to be fitted with a screw-down non-return valve having the spindle so extended that the hand wheel is not less than 460 mm above the bottom platform.

4.6.2 Where two or more cooling water pumps are provided, each capable of supplying cooling water for normal power, only one pump need be fitted with an emergency bilge suction.

4.6.3 In ships with steam propelling machinery, the suction is to have a diameter of at least two-thirds that of the pump suction. In other ships, the suction is to be the same size as the suction branch of the pump.

4.6.4 Where main cooling water pumps are not suitable for bilge pumping duties, the emergency bilge suction is to be led to the largest available power pump, which is not a bilge pump detailed in *Pt 5, Ch 13, 6.1 Number of pumps* and *Pt 5, Ch 13, 6.2 General service pumps*. This pump is to have a capacity not less than that required for a bilge pump and the bilge suction is to be the same size as that of the pump suction branch.

4.6.5 Where the pump to which the emergency bilge suction is connected is of the self-priming type, the direct bilge suction on the same side of the ship as the emergency suction may be omitted, except in passenger ships.

4.6.6 Emergency bilge suction valve nameplates are to be marked 'For emergency use only'.

4.6.7 Where **UMS** (Unattended Machinery Space) notation is to be assigned, the requirements of *Pt 6, Ch 1, 4.6 Bilge level detection 4.6.2* are not applicable for valves serving an emergency bilge system, provided that:

- (a) the emergency bilge valve is normally maintained in a closed position;
- (b) a non-return device is installed in the emergency bilge piping; and
- (c) the emergency bilge suction piping is located inboard of a shell valve that is fitted with the control arrangements complying with *Pt 6, Ch 1, 4.6 Bilge level detection 4.6.2*.

4.7 Tunnel drainage

4.7.1 The tunnel well is to be drained by a suction from the main bilge line. In all ships, including passenger ships, this well may extend to the outer bottom.

4.7.2 Where the tank top in the tunnel slopes down from aft to forward, a bilge suction is to be provided at the forward end of the tunnel, in addition to the tunnel well suction required by *Pt 5, Ch 13, 4.7 Tunnel drainage 4.7.1*.

■ Section 5 SIZES OF BILGE SUCTION PIPES

5.1 Main bilge line

5.1.1 The diameter, d_m , of the main bilge line is to be not less than required by the following formula, to the nearest 5 mm, but in no case is the diameter to be less than that required for any branch bilge suction:

$$d_m = 1,68\sqrt{L(B + D)} + 25 \text{ mm}$$

where

d_m = internal diameter of main bilge line, in mm

B = greatest moulded breadth of ship or maximum breadth of cargo hold for ore carriers, in metres

D = moulded depth to bulkhead deck, in metres

L = Rule length of ship as defined in *Pt 3, Ch 1, 6.1 Principal particulars*, in metres, for ships other than passenger ships

= length between perpendiculars at the extremities of the deepest subdivision load line, in metres, for passenger ships.

5.2 Branch bilge suction to cargo and machinery spaces

5.2.1 The diameter, d_b , of branch bilge suction pipes to cargo and machinery spaces is to be not less than required by the following formula, to the nearest 5 mm, but in no case is the diameter of any suction to be less than 50 mm:

$$d_b = 2,15\sqrt{C(B + D)} + 25\text{mm}$$

where

d_b = internal diameter of branch bilge suction, in mm

C = length of compartment, in metres, and

B and D = are as defined in *Pt 5, Ch 13, 5.1 Main bilge line 5.1.1*.

5.3 Direct bilge suction, other than emergency suction

5.3.1 The direct bilge suction in the main engine room, and the direct bilge suction in large separate boiler rooms, motor rooms of electrically propelled ships and auxiliary engine rooms are not to be of a diameter less than that required for the main bilge line.

5.3.2 Where the separate machinery spaces are of small dimensions, the sizes of the direct bilge suction to these spaces will be specially considered.

5.3.3 For sizes of emergency bilge suction, see *Pt 5, Ch 13, 4.6 Machinery space – Emergency bilge drainage*.

5.4 Main bilge line – Tankers and similar ships

5.4.1 In oil tankers and similar ships, where the engine room pumps do not deal with bilge drainage outside the machinery space, the diameter of the main bilge line may be less than that required by the formula in *Pt 5, Ch 13, 5.1 Main bilge line 5.1.1*, provided that the cross-sectional area is not less than twice that required for the branch bilge suction in the machinery space.

5.5 Distribution chest branch pipes

5.5.1 The area of each branch pipe connecting the bilge main to a distribution chest is to be not less than the sum of the areas required by the Rules for the two largest branch bilge suction pipes connected to that chest, but need not be greater than that required for the main bilge line.

5.6 Tunnel suction

5.6.1 The bilge suction pipe to the tunnel well is to be not less than 65 mm bore, except in ships not exceeding 60 m in length, in which case it may be 50 mm bore.

■ Section 6
Pumps on bilge service and their connections**6.1 Number of pumps**

6.1.1 For ships other than passenger ships, at least two power bilge pumping units are to be provided in the machinery space. In ships of 90 m in length and under, one of these units may be worked from the main engines and the other is to be independently driven. In larger ships both units are to be independently driven.

6.1.2 Each unit may consist of one or more pumps connected to the main bilge line, provided that their combined capacity is adequate.

6.1.3 In ships other than passenger ships, a bilge ejector in combination with a high pressure sea-water pump may be accepted as a substitute for an independent bilge pump as required by *Pt 5, Ch 13, 6.1 Number of pumps 6.1.1*.

6.1.4 Special consideration will be given to the number of pumps for small ships and, in general, if there is a class notation restricting a small ship to harbour or river service, a hand pump may be accepted in lieu of one of the bilge pumping units.

6.1.5 For passenger ships, at least three power bilge pumps are to be provided, one of which may be operated from the main engines. Where the bilge pump numeral as derived from *Regulation 35 - Ventilating systems in machinery spaces* of Chapter II-1 of the *International Convention for the Safety of Life at Sea, 1974*, and applicable amendments, is 30 or more, one additional independent power pump is to be provided.

6.1.6 For location of pumps on passenger ships, see *Pt 5, Ch 13, 8.1 Location of bilge pumps and bilge main*.

6.2 General service pumps

6.2.1 The bilge pumping units, or pumps, required by *Pt 5, Ch 13, 6.1 Number of pumps* may also be used for ballast, fire or general service duties of an intermittent nature, but they are to be immediately available for bilge duty when required, see also SOLAS 1974 as amended Reg. II-2/C, *Regulation 10 - Fire fighting*, as applicable.

6.3 Capacity of pumps

6.3.1 Each bilge pumping unit, or bilge pump in the case of passenger ships, is to be connected to the main bilge line and is to be capable of giving a speed of water through the Rule size of main bilge pipe of not less than 122 m/min.

6.3.2 The capacity of each bilge pumping unit or bilge pump is to be not less than required by the following formula:

$$Q = \frac{5,75}{10^3} d_m^2$$

where

d_m = Rule internal diameter of main bilge line, in mm

Q = capacity, in m³/hour.

6.3.3 In ships other than passenger ships, where one bilge pumping unit is of slightly less than Rule capacity, the deficiency may be made good by an excess capacity of the other unit. In general, the deficiency is to be limited to 30 per cent.

6.4 Self-priming pumps

6.4.1 All power pumps which are essential for bilge services are to be of the self-priming type, unless an approved central priming system is provided for these pumps. Details of this system are to be submitted.

6.4.2 Cooling water pumps having emergency bilge suction need not be of the self-priming type.

6.4.3 For requirements regarding emergency bilge suction, see *Pt 5, Ch 13, 4.6 Machinery space - Emergency bilge drainage*.

6.5 Pump connections

6.5.1 The connections at the bilge pumps are to be such that one unit may continue in operation when the other unit is being opened up for overhaul.

6.5.2 Pumps required for essential services are not to be connected to a common suction or discharge chest or pipe unless the arrangements are such that the working of any pumps so connected is unaffected by the other pumps being in operation at the same time.

6.6 Direct bilge suction

6.6.1 The direct bilge suction in the machinery space(s) are to be led to independent power pump(s), and the arrangements are to be such that these direct suction can be used independently of the main bilge line suction.

■ Section 7**Piping systems and their fittings****7.1 Main bilge line suction**

7.1.1 Suctions from the main bilge line, i.e. branch bilge suction, are to be arranged to draw water from any hold, compartment, watertight section or machinery compartment of the ship, excepting small spaces such as those mentioned in *Pt 5, Ch 13, 3.1 General 3.1.6, Pt 5, Ch 13, 3.5 Fore and after peaks* and *Pt 5, Ch 13, 3.6 Spaces above fore peaks, after peaks and machinery spaces*, where manual pump suction is accepted, and are not to be of smaller diameter than that required by the formula in *Pt 5, Ch 13, 5.2 Branch bilge suction to cargo and machinery spaces 5.2.1*, see also *Pt 5, Ch 13, 7.4 Machinery space suction – Mud boxes 7.4.1* and *Pt 5, Ch 13, 7.5 Hold and other compartment suction – Strum boxes 7.5.1*. For special arrangements for oil tankers, see *Pt 5, Ch 15 Piping Systems for Oil Tankers*.

7.1.2 Where passenger or cargo ships are of a design having enclosed car decks or cargo spaces located on the bulkhead deck or on the freeboard deck special consideration will be given to the drainage arrangements where any fixed pressure water spray system is fitted, see also *Pt 3, Ch 12, 4.1 General* and *Pt 5, Ch 13, 9.1 Bilge drainage requirements*.

7.2 Prevention of communication between compartments

7.2.1 The arrangement of valves, cocks and their connections is to be such as to prevent the possibility of one watertight compartment being placed in communication with another, or of dry cargo spaces, machinery spaces or other dry compartments being placed in communication with the sea or with tanks. For this purpose, screw-down non-return valves are to be provided in the following fittings:

- Bilge valve distribution chests.
- Bilge suction hose connections, whether fitted direct to the pump or on the main bilge line.
- Direct bilge suction and bilge pump connections to main bilge line.

7.3 Isolation of bilge system

7.3.1 Bilge pipes which are required for draining cargo or machinery spaces are to be entirely distinct from sea inlet pipes or from pipes which may be used for filling or emptying spaces where water or oil is carried. This does not, however, exclude a bilge ejection connection, a connecting pipe from a pump to its suction valve chest, or a deep tank suction pipe suitably connected through a changeover device to a bilge, ballast or oil line.

7.4 Machinery space suction – Mud boxes

7.4.1 Suctions for bilge drainage in machinery spaces and tunnels, other than emergency suction, are to be led from easily accessible mud boxes fitted with straight tail pipes to the bilges and having covers secured in such a manner as to permit their being expeditiously opened or closed. Strum boxes are not to be fitted to the lower ends of these tail pipes or to the emergency bilge suction.

7.5 Hold and other compartment suction – Strum boxes

7.5.1 The open ends of bilge suction in holds and other compartments outside machinery spaces and tunnels such as cofferdams and tanks other than those permanently arranged for the carriage of fresh water, water ballast, fuel oil or liquid cargo and for which other efficient means of pumping are provided are to be enclosed in strum boxes having perforations of not more than 10 mm diameter, whose combined area is not less than twice that required for the suction pipe. The boxes are to be so constructed that they can be cleared without breaking any joint of the suction pipe.

7.6 Bilge wells

7.6.1 Bilge wells required by *Pt 5, Ch 13, 3.2 Cargo holds 3.2.3* and *Pt 5, Ch 13, 4.2 Machinery space with double bottom 4.2.2* are to be formed of steel plates and are to be not less than 0,15m³ capacity. In small compartments, steel bilge hats of reasonable capacity may be fitted.

7.6.2 In passenger ships, the depth of bilge wells in double bottom tanks will be specially considered.

7.6.3 Where access manholes to bilge wells are necessary, they are to be fitted as near to the suction strums as practicable.

7.7 Tail pipes

7.7.1 The distance between the foot of all bilge tail pipes and the bottom of the bilge well is to be adequate to allow a full flow of water and to facilitate cleaning.

7.8 Location of fittings

7.8.1 Bilge valves, cocks and mud boxes are to be fitted at, or above, the machinery space and tunnel platforms. Where it is not practicable to avoid the fittings being situated at the starting platform or in passageways, they may be situated just below the platform, provided readily removable traps or covers are fitted and nameplates indicate the presence of these fittings.

7.8.2 Where relief valves are fitted to pumps having sea connections, these valves are to be fitted in readily visible positions above the platform. The arrangements are to be such that any discharge from the relief valves will also be readily visible.

7.9 Bilge pipes in way of double bottom tanks

7.9.1 Bilge suction pipes are not to be led through double bottom tanks if it is possible to avoid doing so.

7.9.2 Bilge pipes which have to pass through these tanks are to have a wall thickness in accordance with *Table 12.2.4 Minimum thickness for steel pipes*. (The thickness of pipes made from material other than steel will be specially considered).

7.9.3 Expansion bends, not glands, are to be fitted to these pipes within the tanks, and the pipes are to be tested, after installation, to the same pressure as the tanks through which they pass.

7.10 Bilge pipes in way of deep tanks

7.10.1 In way of deep tanks, bilge pipes should preferably be led through pipe tunnels but, where this is not done, the pipes are to be of steel, having a wall thickness in accordance with *Table 12.2.4 Minimum thickness for steel pipes* in *Pt 5, Ch 12 Piping Design Requirements*, with welded joints or heavy flanged joints. The number of joints is to be kept to a minimum. Consideration will be given to pipes made from materials other than steel, see also *Pt 5, Ch 12, 5 Plastics pipes*.

7.10.2 Expansion bends, not glands, are to be fitted to these pipes within the tanks, and the open ends of the bilge suction pipes in the holds are to be fitted with non-return valves of the special type approved for use in holds, see *Pt 5, Ch 13, 7.11 Hold bilge non-return valves 7.11.1*.

7.10.3 The pipes are to be tested, after installation, to a pressure not less than the maximum head to which the tanks can be subjected in service.

7.11 Hold bilge non-return valves

7.11.1 Where non-return valves are fitted to the open ends of bilge suction pipes in cargo holds in order to decrease the risk of flooding, they are to be of an approved type which does not offer undue obstruction to the flow of water.

7.12 Blanking arrangements

7.12.1 In case of deep tanks and cargo holds which may be used for either water ballast or dry cargo, provision is to be made for blank flanging the water ballast filling and suction pipes when the tank or hold is being used for the carriage of dry cargo, and for blank flanging the bilge suction pipes when the tank or hold is being used for the carriage of water ballast. Change-over devices may be used for this purpose.

7.12.2 For arrangements when fuel oil or cargo oil (having a flash point of 60°C or above) is carried in deep tanks, see *Pt 5, Ch 14, 4.14 Deep tanks for the alternative carriage of oil, water ballast or dry cargo*.

7.12.3 Where a ship is designed for the alternative carriage of dry cargo or oil having a flash point below 60°C, the blanking arrangements will be specially considered.

■ *Section 8*

Additional requirements for bilge drainage and cross-flooding arrangements for passenger ships

8.1 Location of bilge pumps and bilge main

8.1.1 In passenger ships, the power bilge pumps required by *Pt 5, Ch 13, 6.1 Number of pumps 6.1.5* are to be placed, if practicable, in separate watertight compartments which will not readily be flooded by the same damage. If the engines and boilers are in two or more watertight compartments, the bilge pumps are to be distributed throughout these compartments so far as is possible.

8.1.2 In passenger ships of 91,5 m or more in length, or having a bilge pump numeral of 30 or more (see *Pt 5, Ch 13, 6.1 Number of pumps 6.1.5*), the arrangements are to be such that at least one power pump will be available for use in all ordinary circumstances in which the ship may be flooded at sea. This requirement will be satisfied if:

- one of the pumps is an emergency pump of a submersible type having a source of power situated above the bulkhead deck, or
- the pumps and their sources of power are so disposed throughout the length of the ship that, under any conditions of flooding which the ship is required by statutory regulation to withstand, at least one pump in an undamaged compartment will be available.

8.1.3 The bilge main is to be so arranged that no part is situated nearer the side of the ship than $\frac{B}{5}$, measured at right angles to the centreline at the level of the deepest sub-division load line, where B is the breadth of the ship.

8.1.4 Where any bilge pump or its pipe connection to the bilge main is situated outboard of the $\frac{B}{5}$ line, then a non-return valve is to be provided in the pipe connection at the junction with the bilge main. The emergency bilge pump and its connections to the bilge main are to be so arranged that they are situated inboard of the $\frac{B}{5}$ line.

8.2 Prevention of communication between compartments in the event of damage

8.2.1 Provision is to be made to prevent the compartment served by any bilge suction pipe being flooded, in the event of the pipe being severed, or otherwise damaged by collision or grounding in any other compartment. For this purpose, where the pipe is at any part situated nearer the side of the ship than $\frac{B}{5}$ or in a duct keel, a non-return valve is to be fitted to the pipe in the compartment containing the open end.

8.3 Arrangement and control of bilge valves

8.3.1 All the distribution boxes, valves and cocks in connection with the bilge pumping arrangements are to be so arranged that, in the event of flooding, one of the bilge pumps may be operative on any compartment. If there is only one system of pipes common to all pumps, the necessary valves or cocks for controlling the bilge suction must be capable of being operated from the bulkhead deck. Where, in addition to the main bilge pumping system, an emergency bilge pumping system is provided, it is to be independent of the main system and so arranged that a pump is capable of operating on any compartment under flooding conditions; in this case, only the valves and cocks necessary for the operation of the emergency system need be capable of being operated from above the bulkhead deck.

8.3.2 All valves and cocks mentioned in *Pt 5, Ch 13, 8.3 Arrangement and control of bilge valves 8.3.1* which can be operated from above the bulkhead deck are to have their controls at their place of operation clearly marked and provided with means to indicate whether they are open or closed.

8.4 Cross-flooding arrangements

8.4.1 Where divided deep tanks or side tanks are provided with cross-flooding arrangements to limit the angle of heel after side damage, the arrangements are to be self-acting where practicable. In any case, where controls to cross-flooding fittings are provided, they are to be operable from above the bulkhead deck.

■ Section 9**Additional requirements relating to fixed pressure water spray fire-extinguishing systems****9.1 Bilge drainage requirements**

9.1.1 Where arrangements for cooling cargo, Ro-Ro or special category spaces below the bulkhead or freeboard deck, or fire-fighting by means of fixed spraying nozzles or by flooding of these spaces with water are provided, the following provisions are to apply, see also IMO guidelines (*MSC.1/Circular.1320 – Guidelines for the Drainage of Fire-Fighting Water From Closed Vehicle and Ro-Ro Spaces and Special Category Spaces of Passenger and Cargo Ships – (11 June 2009)*):

- (a) The drainage system is to be sized to remove no less than 125 per cent of the combined capacity of both the water spraying system pumps and the required number of fire hose nozzles.
- (b) The drainage system valves are to be operable from outside the protected space at a position in the vicinity of the extinguishing system controls.
- (c) Adequately sized bilge wells are to be located at the side shell of the ship at a distance from each other of not more than 40 m in each watertight compartment, the bilge wells should be uniformly distributed fore and aft, see also *Pt 3, Ch 12, 4.1 General 4.1.4* and *Pt 4, Ch 2, 11.2 Openings in main vehicle deck*. For cargo ships only, if this is not possible, the free surface effect on the ship's stability is to be determined and submitted to the Flag Administration for appraisal.

9.1.2 If drainage of vehicle or cargo spaces is by gravity, the drainage is to be led directly overboard or to a closed drain tank. If led overboard the scuppers are to comply with *Pt 3, Ch 12, 4.1 General 4.1.3*. If led to a closed drain tank, this tank is to be located outside the machinery spaces and provided with a vent pipe leading to a safe location on the open deck. See also *Pt 4, Ch 2, 11.2 Openings in main vehicle deck*.

9.1.3 Drainage from a cargo space into bilge wells in a lower space is only permitted if that space satisfies the same requirements as the cargo space above.

9.1.4 On ships with closed vehicle spaces, ro-ro spaces and special category spaces, means are to be provided to prevent the blockage of drainage systems from these spaces.

■ Section 10**Drainage arrangements for ships not fitted with propelling machinery****10.1 Pumps**

10.1.1 Where auxiliary power is not provided, hand pumps are to be fitted, in number and position, as may be required for the efficient drainage of the ship.

10.1.2 In general, one hand pump is to be provided for each compartment. Alternatively, two hand pumps connected to a bilge main, having at least one branch to each compartment, are to be provided.

10.1.3 For unmanned pontoons and as an alternative to *Pt 5, Ch 13, 10.1 Pumps 10.1.1* and *Pt 5, Ch 13, 10.1 Pumps 10.1.2*, two portable pumps are to be provided together with suitable suction and discharge hoses as applicable. This equipment is to be either stored on board the pontoon or carried on board an attending tug.

10.1.4 The pumps are to be capable of being worked from the upper deck or from positions above the load waterline which are at all times readily accessible. The suction lift is not to exceed 7,3 m and is to be well within the capacity of the pump.

10.1.5 The sizes of the hand pumps are to be not less than those given in *Table 13.10.1 Sizes of hand pumps*. Where the ship is closely sub-divided into small watertight compartments, 50 mm bore suctions will be accepted.

Table 13.10.1 Sizes of hand pumps

Tonnage under upper deck	Diameter of barrel of bucket pump	Bore of suction pipe of bucket pumps and semi-rotary pumps
	mm	mm
Not exceeding 500 tons	100	50
Above 500 tons but not exceeding 1000 tons	115	57
Above 1000 tons but not exceeding 2000 tons	125	65
Above 2000 tons	140	70

10.2 Ships with auxiliary power

10.2.1 In ships in which auxiliary power is available on board, power pump suction are to be provided for dealing with the drainage of tanks and of the bilges of the principal compartments.

10.2.2 The pumping arrangements are to be as required for self-propelled ships, so far as these requirements are applicable, duly modified to suit the size and service of the ship.

10.2.3 Details of the pumping arrangements are to be submitted for special consideration.

■ Section 11 Ballast system

11.1 Stand-by arrangements for ballast pumping

11.1.1 Where ballasting/de-ballasting is required for ship operation or trading purposes stand-by ballast pumping arrangements are to be provided, see also Pt 5, Ch 13, 6.2 General service pumps 6.2.1 and Pt 5, Ch 15, 2.4 Drainage of ballast tanks and void spaces within the range of the cargo tanks 2.4.4.

11.2 Integrated cargo and ballast systems

11.2.1 Where ballast and cargo systems share power supplies and/or control engineering systems, the additional requirements of this sub-Section apply.

11.2.2 A failure is not to prevent operation of the ballast system by other means.

11.2.3 Controls to stop the cargo system, including normal controls and emergency stop and safety shutdowns, are not to prevent operation of the ballast system.

■ Section 12 Air, overflow and sounding pipes

12.1 Definitions

12.1.1 Reference to cargo oil in this Section is to be taken to mean cargo oil which has a flash point 60°C or above (closed cup test).

12.2 Materials

12.2.1 Air, overflow and sounding pipes are to be made of steel or other approved material. For use of plastics pipes of approved type, see *Pt 5, Ch 12 Piping Design Requirements*.

12.2.2 The portions of air, overflow and sounding pipes fitted above the weather deck are to be of steel or equivalent material.

12.3 Nameplates

12.3.1 Nameplates are to be affixed to the upper ends of all air and sounding pipes.

12.4 Air pipes

12.4.1 Air pipes are to be fitted to all tanks, cofferdams, tunnels and other compartments which are not fitted with alternative ventilation arrangements.

12.4.2 The air pipes are to be fitted at the opposite end of the tank to that which the filling pipes are placed and/or at the highest part of the tank. Where the tank top is of unusual or irregular profile, special consideration will be given to the number and position of the air pipes.

12.4.3 For a normally inaccessible small void compartment such as an echo sounding compartment, which is accessed from within a normally inaccessible space such as a forepeak tank, alternative air pipe arrangements to those required by *Pt 5, Ch 13, 12.4 Air pipes 12.4.1* may be considered. For such arrangements, a warning notice is to be located in a prominent position specifying the precautions to be taken prior opening the manhole and entering the small void compartment. Ventilation arrangements are to be submitted to LR for approval.

12.4.4 For unmanned pontoons not fitted with auxiliary power and where portable pumps are provided in accordance with *Pt 5, Ch 13, 10.1 Pumps 10.1.3*, void spaces need not be provided with air pipes or any other means of ventilation. In this case, a warning notice is to be placed in a prominent position specifying the precautions to be taken prior to opening a manhole of a void space.

12.5 Termination of air pipes

12.5.1 Air pipes to double bottom tanks, deep tanks extending to the shell plating, or tanks which can be run up from the sea are to be led to above the bulkhead deck. Air pipes to fuel oil and cargo oil tanks, cofferdams and all tanks which can be pumped up are to be led to the open. For height of air pipes above deck, see *Pt 3, Ch 12, 3 Air and sounding pipes*.

12.5.2 Air pipes from storage tanks containing lubricating or hydraulic oil may terminate in the machinery space, provided that the open ends are so situated that issuing oil cannot come into contact with electrical equipment or heated surfaces. Air pipes from heated lubricating oil tanks are to be led to the open.

12.5.3 The open ends of air pipes to fuel oil and cargo oil tanks are to be situated where no danger will be incurred from issuing oil vapour when the tank is being filled.

12.5.4 The location and arrangement of air pipes for fuel oil service, settling and lubricating oil tanks are to be such that in the event of a broken vent pipe, this does not directly lead to the risk of ingress of sea-water or rainwater.

12.5.5 For special requirements for the termination of air pipes on ferries, see *Pt 3, Ch 12, 3 Air and sounding pipes* and *Pt 4, Ch 2, 11 Miscellaneous openings*.

12.6 Gauze diaphragms

12.6.1 The open ends of air pipes to fuel oil and cargo oil tanks are to be furnished with a wire gauze diaphragm of incorrodible material which can be readily removed for cleaning or renewal.

12.6.2 Where wire gauze diaphragms are fitted at air pipe openings, the area of the opening through the gauze is to be not less than the cross-sectional area required for the pipe, see *Pt 5, Ch 13, 12.8 Size of air pipes*.

12.7 Air pipe closing appliances

12.7.1 The closing appliances fitted to tank air pipes in accordance with *Pt 3, Ch 12, 3 Air and sounding pipes* are to be of an automatic opening type which will allow the free passage of air or liquid to prevent the tanks being subjected to a pressure or vacuum greater than that for which they are designed, and prevent the free entry of water into the tanks.

12.7.2 Air pipe closing devices are to be type a tested in accordance with the test requirements of LR's Type Approval Test Specification Number 2. The flow characteristic of the closing device is to be determined using water, see *Pt 5, Ch 13, 12.8 Size of air pipes 12.8.1* and *Pt 5, Ch 13, 12.8 Size of air pipes 12.8.2*.

12.7.3 Wood plugs and other devices which can be secured closed are not to be fitted at the outlets.

12.7.4 Air pipe automatic closing devices shall be so designed that they will withstand both ambient conditions as indicated in *Pt 5, Ch 1, 3.5 Ambient reference conditions* and *Pt 5, Ch 1, 3.6 Ambient operating conditions* and designed working conditions, and be suitable for use at inclinations up to and including $\pm 40^\circ$.

12.7.5 Air pipe automatic closing devices shall be constructed to allow inspection of the closure and the inside of the casing as well as changing the seals.

12.7.6 Efficient ball or float seating arrangements are to be provided for the closures. Bars, cages or other devices are to be provided to prevent the ball or float from contacting the inner chamber in its normal state, and made in such a way that the ball or float is not damaged when subjected to liquid impact due to a tank being overfilled.

12.7.7 Air pipe automatic closing devices are to be self-draining.

12.7.8 The clear area through an air pipe closing device in the open position shall be at least equal to the area of the inlet.

12.7.9 In the case of air pipe closing devices of the float type, suitable guides are to be provided to ensure unobstructed operation under all working conditions of heel and trim as specified in *Pt 5, Ch 13, 12.7 Air pipe closing appliances 12.7.4*.

12.7.10 The maximum allowable tolerances for wall thickness of floats shall not exceed ± 10 per cent of thickness.

12.7.11 The inner and the outer chambers of an automatic air pipe head are to be of a minimum thickness of 6 mm.

12.7.12 Casings of air pipe closing devices are to be of approved metallic materials, adequately protected against corrosion.

12.7.13 For galvanised steel air pipe heads, the zinc coating is to be applied by the hot method and the thickness is to be 70 to 100 microns.

12.7.14 For areas of the head susceptible to erosion (e.g. those parts directly subjected to ballast water impact when the tank is being pressed up, such as the inner chamber area above the air pipe plus an overlap of 10° or more either side) an additional harder coating should be applied. This is to be an aluminium-bearing epoxy, or other equivalent coating, applied over the zinc.

12.7.15 Closures and seats made of non-metallic materials are to be compatible with the media intended to be carried in the tank and to sea-water, and suitable for operating at ambient temperatures between -25°C and 85°C .

12.8 Size of air pipes

12.8.1 For every tank which can be filled by the ship's pumps, the total cross-sectional area of the air pipes and the design of the air pipe closing devices is to be such that when the tank is overflowing at the maximum pumping capacity available for the tank, it will not be subjected to a pressure greater than that for which it is designed.

12.8.2 In all cases, whether a tank is filled by ship's pumps or other means, the total cross-sectional area of the air pipes is to be not less than 25 per cent greater than the effective area of the respective filling pipe.

12.8.3 Where tanks are fitted with cross-flooding connections, the air pipes are to be of adequate area for these connections.

12.8.4 Air pipes are to be not less than 50 mm bore.

12.9 Overflow pipes

12.9.1 For all tanks which can be filled by the ship's pumps or by shore pumps, overflow pipes are to be fitted where:

(a) The total cross-sectional area of the air pipe is less than that required by *Pt 5, Ch 13, 12.8 Size of air pipes*.

(b) The pressure head corresponding to the height of the air pipe is greater than that for which the tank is designed.

12.9.2 In the case of fuel oil and lubricating oil tanks, the overflow pipe is to be led to an overflow tank of adequate capacity or to a storage tank having a space reserved for overflow purposes. Suitable means are to be provided to indicate when overflow is occurring, or when the contents reach a predetermined level in the tanks.

12.9.3 Overflow pipes are to be self-draining under normal conditions of trim.

12.9.4 Where overflow sight glasses are provided, they are to be in a vertically dropping line and designed such that the oil does not impinge on the glass. The glass is to be of heat resisting quality, adequately protected from mechanical damage and well lit.

12.10 Air and overflow systems

12.10.1 Where a combined air or overflow system is fitted, the arrangement is to be such that in the event of any one of the tanks being bilged, tanks situated in other watertight compartments of the ship cannot be flooded from the sea through combined air pipes or the overflow main. For this purpose, it will normally be necessary to lead the overflow pipe to a point close to the bulkhead deck.

12.10.2 In the case of trawlers and fishing vessels, the arrangement is to be such that in the event of any one of the tanks being bilged, the other tanks cannot be flooded from the sea through the combined air pipes or the overflow main.

12.10.3 Where overflow from tanks which are used for the alternative carriage of oil and water ballast are connected to an overflow system, arrangements are to be made to prevent water ballast overflowing into tanks containing oil, see also *Pt 5, Ch 14, 4.14 Deep tanks for the alternative carriage of oil, water ballast or dry cargo*.

12.10.4 Where a common overflow main is provided, the main is to be sized to allow any two tanks connected to that main to overflow simultaneously.

12.11 Sounding arrangements

12.11.1 Provision is to be made for sounding all tanks and the bilges of those compartments which are not at all times readily accessible. The soundings are to be taken as near the suction pipes as practicable.

12.11.2 Bilges of compartments which are not at all times readily accessible are to be provided with sounding pipes.

12.11.3 Where fitted, sounding pipes are to be as straight as practicable, and if curved to suit the structure of the ship, the curvature must be sufficiently easy to permit the ready passage of the sounding rod or chain.

12.11.4 Sounding devices of approved type may be used in lieu of sounding pipes for sounding tanks. These devices are to be tested, after fitting on board, to the satisfaction of the Surveyors.

12.11.5 Where gauge glasses are used for indicating the level of liquid in tanks containing lubricating oil, fuel oil or other flammable liquid, the glasses are to be of the flat type of heat-resisting quality, adequately protected from mechanical damage, and fitted with self-closing valves at the lower ends and at the top ends if these are connected to the tanks below the maximum liquid level.

12.11.6 If means of sounding, other than a sounding pipe, is fitted in any ship for indicating the level of liquid in tanks containing fuel oil, lubricating oil or other flammable liquid, failure of such means or over filling of the tank should not result in the release of tank contents.

12.11.7 In passenger ships, sounding devices for fuel oil tanks, lubricating oil tanks and other tanks which may contain flammable liquids are to be of a type which does not require penetration below the top of the tank.

12.11.8 For a normally inaccessible small void compartment such as an echo sounding compartment, which is accessed from within a normally inaccessible space such as a forepeak tank, alternative sounding arrangements to those required by *Pt 5, Ch 13, 12.11 Sounding arrangements 12.11.1* may be considered. For such arrangements, a warning notice is to be located in a prominent position specifying precautions to be taken prior opening the manhole of the small void compartment. Means are to be provided to indicate flooding of the compartment without opening, such as fitting indicator plugs to the manhole. Sounding arrangements are to be submitted to LR for approval.

12.12 Termination of sounding pipes

12.12.1 Sounding pipes are to be led to positions above the bulkhead deck which are at all times accessible and, in the case of fuel oil tanks, cargo oil tanks, lubricating oil tanks and tanks containing other flammable oils, the sounding pipes are to be led to safe positions on the open deck.

12.12.2 For closing requirements, see also *Pt 3, Ch 12, 3 Air and sounding pipes*.

12.13 Short sounding pipes

12.13.1 In machinery spaces and tunnels, in circumstances where it is not practicable to extend the sounding pipes as mentioned in *Pt 5, Ch 13, 12.12 Termination of sounding pipes*, short sounding pipes extending to well lighted, readily accessible positions above the platform may be fitted to double bottom tanks. Where such pipes serve tanks containing fuel oil or other flammable liquid, an additional sounding device of approved type is to be fitted. An additional sounding device is not required for lubricating oil tanks. Any proposal to terminate in the machinery space, sounding pipes to tanks, other than double bottom tanks, will be the subject of special consideration.

12.13.2 Short sounding pipes to fuel oil, cargo oil (flash point not less than 60°C), lubricating oil tanks and other flammable oil tanks (flash point not less than 60°C) are to be fitted with cocks having parallel plugs with permanently attached handles, so loaded that, on being released, they automatically close the cocks. In addition, a small diameter self-closing test cock is to be fitted below the cock mentioned above in order to ensure that the sounding pipe is not under a pressure of oil before opening-up the sounding cock. Provision is to be made to ensure that discharge of oil through this test cock does not present an ignition hazard. An additional small diameter self-closing test cock is not required for lubricating oil tanks.

12.13.3 As a further precaution against fire, such sounding pipes are to be located in positions as far removed as possible from any heated surface or electrical equipment and, where necessary, effective shielding is to be provided in way of such surfaces and/or equipment.

12.13.4 In ships that are required to be provided with a double bottom, short sounding pipes, where fitted to double bottom tanks, are in all cases to be provided with self-closing cocks as described in *Pt 5, Ch 13, 12.13 Short sounding pipes 12.13.2*.

12.13.5 Where a double bottom is not required to be fitted, short sounding pipes to tanks other than oil tanks are to be fitted with shut-off cocks or with screw caps attached to the pipes by chains.

12.13.6 In passenger ships, short sounding pipes are permissible only for sounding cofferdams and double bottom tanks situated in a machinery space, and are in all cases to be fitted with self-closing cocks as described in *Pt 5, Ch 13, 12.13 Short sounding pipes 12.13.2*.

12.14 Elbow sounding pipes

12.14.1 Elbow sounding pipes are not to be used for deep tanks unless the elbows and pipes are situated within closed cofferdams or within tanks containing similar liquids. They may, however, be fitted to other tanks and may be used for sounding bilges, provided that it is not practicable to lead them direct to the tanks or compartments, and subject to any subdivision and damage stability requirements that may apply, see *Pt 5, Ch 13, 1.2 Prevention of progressive flooding in damage condition 1.2.1*.

12.14.2 The elbows are to be of heavy construction and adequately supported.

12.14.3 In passenger ships, elbow sounding pipes are not permissible.

12.15 Striking plates

12.15.1 Striking plates of adequate thickness and size are to be fitted under open-ended sounding pipes.

12.15.2 Where slotted sounding pipes having closed ends are employed, the closing plugs are to be of substantial construction.

12.16 Sizes of sounding pipes

12.16.1 Sounding pipes are to be not less than 32 mm bore.

12.16.2 All sounding pipes, whether for compartments or tanks, which pass through refrigerated spaces or the insulation thereof, in which the temperatures contemplated are 0°C or below, are to be not less than 65 mm bore, see also *Pt 5, Ch 13, 2.8 Piping in way of refrigerated chambers 2.8.1* for insulation.



Cross-references

For 'Ice Class' requirements, see *Pt 8 Rules for Ice and Cold Operations*.

For venting and gauging equipment for cargo tanks in oil tankers, see *Pt 5, Ch 15, 4 Cargo tank venting, purging and gas-freeing* and *Pt 5, Ch 15, 5 Cargo tank level gauging equipment*.

For control engineering equipment, see *Pt 6, Ch 1 Control Engineering Systems*.

For requirements relating to scuppers and sanitary discharges, see *Pt 3, Ch 12 Ventilators, Air Pipes and Discharges*.

■ *Section 13*

Additional requirements for drainage and pumping arrangements for bulk carriers

13.1 General requirements

13.1.1 Arrangements for drainage and pumping are to be in accordance with the requirements of SOLAS 1974 as amended, Chapter XII, *Regulation 13 - Availability of pumping systems*¹.

13.1.2 On bulk carriers, the means for draining and pumping ballast tanks forward of the collision bulkhead and bilges of dry spaces any part of which extends forward of the foremost cargo hold are to be capable of being brought into operation from a readily accessible enclosed space, the location of which is accessible from the navigation bridge or propulsion machinery control positions without traversing exposed freeboard or superstructure decks. Where pipes serving such tanks or bilges pierce the collision bulkhead, valve operation by means of remotely operated actuators may be accepted, as an alternative to the valve control specified in *Pt 5, Ch 13, 3.5 Fore and after peaks 3.5.4*, provided that the location of such valve controls complies with this requirement.

13.2 Dewatering capability

13.2.1 The dewatering system for ballast tanks located forward of the collision bulkhead, and for bilges of dry spaces any part of which extends forward of the foremost cargo hold, is to be designed to remove water from the forward spaces at a rate of not less than $320A \text{ m}^3/\text{h}$, where A is the crosssectional area in m^2 of the largest air pipe or ventilator pipe connected from the exposed deck to a closed forward space that is required to be dewatered by these arrangements.

■ *Section 14*

Water ingress detection arrangements

14.1 General requirements

14.1.1 Equipment for detecting the ingress of water in bulk carriers is to be fitted in accordance with the requirements of SOLAS 1974 as amended, Chapter XII, *Regulation 12 - Hold, ballast and dry space water ingress alarms*.

14.1.2 Equipment for detecting the ingress of water in single hold cargo ships is to be fitted in accordance with the requirements of SOLAS 1974 as amended, Chapter II-1, *Regulation 25 - Water level detectors on single hold cargo ships other than bulk carriers*.

14.1.3 Flooding detection systems in passenger ships carrying 36 persons or more are to be fitted in accordance with the requirements of SOLAS 1974 as amended, Chapter II-1, *Regulation 22-1 - Flooding detection systems for passenger ships carrying 36 or more persons constructed on or after 1 July 2010*.

14.1.4 Alarm and indicators specified in *Pt 5, Ch 13, 14.2 Water ingress detection arrangements in bulk carriers to Pt 5, Ch 13, 14.4 Flooding detection systems in passenger ships* are to be provided on the navigation bridge and, for passenger ships, additionally in the safety centre if located in a separate space from the navigation bridge.

14.1.5 Equipment required by *Pt 5, Ch 13, 14.1 General requirements 14.1.2 to Pt 5, Ch 13, 14.1 General requirements 14.1.4* is to satisfy the applicable requirements of *Pt 6, Ch 1 Control Engineering Systems*.

14.1.6 *Pt 6, Ch 1, 1.3 Control, alarm and safety equipment 1.3.1* details applicable requirements for Survey at the manufacturer's works. At the initial installation and during each subsequent Complete Survey of Machinery alarm systems or Special Survey, the operation of the ingress detection arrangements is to be demonstrated to the satisfaction of the LR Surveyor.

14.1.7 Where alternative arrangements to those required by *Pt 5, Ch 13, 14.1 General requirements 14.1.2 to Pt 5, Ch 13, 14.1 General requirements 14.1.4* are proposed, evidence is to be submitted for consideration by LR that demonstrates:

- water ingress will be detected in all areas considered necessary to reliably detect flooding of watertight spaces;
 - responsible personnel will be effectively notified in the event of water ingress to allow for planned response; and
 - acceptance by the National Administration with which the ship is registered.
-

14.2 Water ingress detection arrangements in bulk carriers

14.2.1 Bulk carriers are to be fitted with water level detectors:

- (a) in each cargo hold, giving audible and visual alarms, one when the water level above the inner bottom in any hold reaches a height of 0,5 m and another at a height not less than 15 per cent of the depth of the cargo hold but not more than 2 m. The water level detectors are to be fitted in the aft end of each cargo hold. For cargo holds which are used for water ballast, an alarm overriding device may be installed. The visual alarms are to clearly discriminate between the two different water levels detected in each hold;
- (b) in any ballast tank forward of the collision bulkhead required by *Pt 3, Ch 3, 4 Bulkhead requirements*, giving an audible and visual alarm when the liquid in the tank reaches a level not exceeding 10 per cent of the tank capacity. An alarm overriding device may be installed to be activated when the tank is in use; and
- (c) in any dry or void space other than a chain cable locker, any part of which extends forward of the foremost cargo hold, giving an audible and visual alarm at a water level of 0,1 m above the deck. Such alarms need not be provided in enclosed spaces the volume of which does not exceed 0,1 per cent of the ship's maximum displacement volume.

14.3 Water ingress detection arrangements in single hold cargo ships

14.3.1 Ships having a length, *L*, of less than 80 m and a single cargo hold below the freeboard deck or cargo holds below the freeboard deck which are not separated by at least one bulkhead made watertight up to that deck, are to be fitted in such space or spaces with water level detectors.

14.3.2 The water level detectors required by *Pt 5, Ch 13, 14.3 Water ingress detection arrangements in single hold cargo ships 14.3.1* are to:

- (a) give an audible and visual alarm when the water level above the inner bottom in the cargo hold reaches a height of not less than 0,3 m, and another when such level reaches not more than 15 per cent of the mean depth of the cargo hold; and
- (b) be fitted at the aft end of the hold, or above its lowest part where the inner bottom is not parallel to the designed waterline. Where webs or partial watertight bulkheads are fitted above the inner bottom, the installation of additional detectors is to be considered.

14.3.3 The water level detectors required by *Pt 5, Ch 13, 14.3 Water ingress detection arrangements in single hold cargo ships 14.3.1* need not be fitted in ships complying with *Pt 5, Ch 13, 14.2 Water ingress detection arrangements in bulk carriers*, or in ships having watertight side compartments each side of the cargo hold length which extend vertically at least from inner bottom to freeboard deck.

14.4 Flooding detection systems in passenger ships

14.4.1 Passenger ships for 36 persons or more are to be provided with a flooding detection system for watertight spaces below the bulkhead deck.

14.4.2 The flooding detection system required by *Pt 5, Ch 13, 14.4 Flooding detection systems in passenger ships 14.4.1* is to be fitted in all watertight spaces below the bulkhead deck that:

- (a) have a volume, in cubic metres, that is more than the ship's moulded displacement per centimetre immersion at deepest subdivision draught; or
- (b) have a volume more than 30 cubic metres, whichever is the greater.

14.4.3 Any watertight spaces that are individually equipped with a liquid level monitoring system (such as fresh water, ballast water, fuel, etc.), including an indicator panel or other means of monitoring at the navigation bridge, and the safety centre if located in a separate space from the navigation bridge, are excluded from the requirements of this sub-Section.

14.4.4 The number and location of flooding detection sensors is to be sufficient to ensure that any substantial water ingress into a watertight space requiring a flooding detection system is detected under reasonable angles of trim and heel. To accomplish this, flooding detection sensors are to be installed as indicated below:

- (a) **Vertical location** – sensors are to be installed as low as practical in the watertight space;
- (b) **Longitudinal location** – in watertight spaces located forward of the mid-length sensors are generally to be installed at the forward end of the space; and in watertight spaces located aft of the mid-length, sensors are generally to be installed at the aft end of the space. For watertight spaces located in the vicinity of the midlength, consideration is to be given to the appropriate longitudinal location of the sensor. In addition, any watertight space of length more than 20 per cent of the ship's subdivision length or with arrangements that would seriously restrict the longitudinal flow of water is to be provided with sensors at both the forward and aft ends; and

(c) **Transverse location** – sensors are generally to be installed at the centreline of the space (or alternatively at both the port and starboard sides). In addition, any watertight space that extends the full breadth of the ship or with arrangements that would seriously restrict the transverse flow of water is to be provided with sensors at both the port and starboard sides.

14.4.5 Where a watertight space extends in height over more than one deck, there is to be at least one flooding detection sensor at each deck level. This provision is not applicable in cases where a continuous flood level monitoring system is installed.

14.4.6 Consideration may be given to the number and location of flooding detection sensors in watertight spaces with unusual arrangements or in other cases where these requirements would not achieve the intended purpose, see *Pt 5, Ch 13, 14.1 General requirements 14.1.7*.

Section

-
- 1 **General requirements**
 - 2 **Fuel oil - General requirements**
 - Cross-reference**
 - 3 **Fuel oil burning arrangements**
 - 4 **Fuel oil pumps, pipes, fittings, tanks, etc.**
 - 5 **Steam piping systems**
 - Cross-reference**
 - 6 **Boiler feed water, condensate and thermal fluid circulation systems**
 - Cross-reference**
 - 7 **Engine cooling water systems**
 - Cross-reference**
 - 8 **Lubricating oil systems**
 - Cross-references**
 - 9 **Hydraulic systems**
 - 10 **Low pressure compressed air systems**
 - 11 **Multi-engined ships**
 - 12 **Control, alarm and safety systems of machinery**
-

■ *Section 1*
General requirements

1.1 General

1.1.1 In addition to the requirements detailed in this Chapter, the requirements of *Pt 5, Ch 13, 1 General requirements* and *Pt 5, Ch 13, 2 Construction and installation* are to be complied with, where applicable.

1.1.2 The requirements of *Pt 5, Ch 13, 3 Drainage of compartments, other than machinery spaces* are also to be complied with, so far as they are applicable, for the drainage of tanks, oily bilges and cofferdams, etc.

1.1.3 The requirements of *Pt 5, Ch 14, 2 Fuel oil - General requirements* and *Pt 5, Ch 14, 4 Fuel oil pumps, pipes, fittings, tanks, etc.* are to be complied with, as far as they are applicable, for all flammable liquids.

■ *Section 2*
Fuel oil - General requirements

2.1 Flash point

2.1.1 The flash point (closed cup test) of fuel oil for use in ships classed for unrestricted service is, in general, to be not less than 60°C. For emergency generator engines a flash point of not less than 43°C is permissible.

2.1.2 The use of fuel oil having a flash point of less than 60° but not less than 43° may be permitted for emergency generators, emergency fire pumps, engines and auxiliary machines which are not located in machinery spaces subject to the requirements of *Pt 5, Ch 14, 4.19 Arrangements for fuels with a flash point between 43°C and 60°C*.

2.1.3 The use of fuel having a lower flash point than specified in *Pt 5, Ch 14, 2.1 Flash point 2.1.1* or *Pt 5, Ch 14, 2.1 Flash point 2.1.2* may be permitted in cargo ships provided that such fuel is not stored in any machinery space and the arrangements for the complete installation are specially approved.

2.1.4 Fuel oil in storage tanks is not to be heated to a temperature exceeding 10°C below its flash point. Higher temperatures will be considered for fuel oil stored in settling and service tanks where:

- (a) The tanks are vented to a safe position outside the engine-room and, as in the case of all fuel oil tanks, the ends of the ventilation pipes are fitted with gauze diaphragms.
- (b) Openings in the drainage systems of tanks containing heated fuel oil are located in spaces where no accumulation of oil vapours at temperatures close to the flash point can occur.
- (c) The length of vent pipes from such tanks and/or a cooling device is sufficient for cooling oil vapours to below 60°C, or the outlet of the vent pipes is located at least 3 m from sources of ignition.
- (d) There is no source of ignition in the vicinity of openings in the drainage systems.
- (e) There are no openings from the vapour space of the fuel tanks into machinery spaces other than bolted manhole covers.
- (f) Enclosed spaces are not located directly over such fuel tanks, except for vented cofferdams.
- (g) Electrical equipment is not fitted in the vapour space of tanks unless it meets the requirements of *Pt 6, Ch 2, 14.2 Selection of equipment for use in explosive gas atmospheres 14.2.4* for electrical equipment in zone 0 explosive atmospheres.

2.1.5 The temperature of any heating medium is not to exceed 220°C.

2.2 Special fuels

2.2.1 When it is desired to carry a quantity of fuel having a flash point below 43°C for special services, e.g. aviation spirit for use in helicopters, full particulars of the proposed arrangements are to be submitted for special consideration. For helicopter refuelling, as a minimum, the requirements of SOLAS 1974 as amended II-2/G, *Regulation 18 - Helicopter facilities* will apply.

2.2.2 For the burning of methane gas in methane tankers, see the *18 Rules and Regulations for the Construction and Classification of Ships for the Carriage of Liquefied Gases in Bulk, July 2015* (hereinafter referred to as the Rules for Ships for Liquefied Gases).

2.2.3 Where it is proposed to use gaseous fuels for main or auxiliary engines in ships other than LNG carriers, the relevant requirements of the *Rules and Regulations for the Classification of Natural Gas Fuelled Ships, July 2015* are to be complied with. Full particulars of the proposed arrangements are to be submitted for special consideration. Attention is to be given to any relevant statutory requirements of the National Authority of the country in which the ships are to be registered.

2.3 Fuel oil sampling

2.3.1 Sampling points are to be provided at locations within the fuel oil system that enable samples of fuel oil to be taken in a safe manner.

2.3.2 The position of a sampling point is to be such that the sample of the fuel oil is representative of the fuel oil quality at that location within the system.

Note Samples taken from sounding pipes are not considered to be representative of the tank's contents.

2.3.3 The sampling arrangements within the machinery space are to be capable of safely providing samples when machinery is running and are to be provided with isolating valves and cocks of the self-closing type. The sampling points are to be located in positions as far removed as possible from any heated surface or electrical equipment so as to preclude impingement of fuel oil onto such surfaces on equipment under all operating conditions, see *Pt 5, Ch 1, 3.7 Inclination of ship*.

2.4 Ventilation

2.4.1 The spaces in which the fuel oil burning appliances and the fuel oil settling and service tanks are fitted are to be well ventilated and easy to access.

2.5 Boiler insulation and air circulation in boiler room

2.5.1 The boilers are to be suitably lagged. The clearance spaces between the boilers and tops of the double bottom tanks, and between the boilers and the sides of the storage tanks in which fuel oil and cargo oil is carried, are to be adequate for the free circulation of the air necessary to keep the temperature of the stored oil sufficiently below its flash point.

2.5.2 Where water tube boilers are installed, there is to be a space of at least 760 mm between the tank top and the underside of the pans forming the bottom of the combustion spaces.

2.5.3 Smoke-box doors are to be shielded and well fitting, and the uptake joints made gastight. Where the surface temperature of the uptakes may exceed 220°C, they are to be efficiently lagged to minimise the risk of fire and to prevent damage by heat. Where lagging covering the uptakes, including flanges, is oil-absorbing or may permit penetration of oil, the lagging is to be encased in sheet metal or equivalent. In locations where the Surveyor is satisfied that oil impingement could not occur, the lagging need not be encased.

2.6 Funnel dampers

2.6.1 Dampers which are capable of completely closing the gas passages are not to be fitted to inner funnels of ships equipped for burning fuel oil only. In ships burning oil or coal alternatively, dampers may be retained, if they are provided with a suitable device whereby they may be securely locked in the fully open position.

2.7 Heating arrangements

2.7.1 Where steam is used for heating fuel oil, cargo oil or lubricating oil, in bunkers, tanks, heaters or separators, the exhaust drains are to discharge the condensate into an observation tank in a well lighted and accessible position where it can be readily seen whether or not it is free from oil, see *Pt 5, Ch 15, 6.4 Heating circuits*.

2.7.2 Where hot water is used for heating, means are to be provided for detecting the presence of oil in the return lines from the heating coils.

2.7.3 Where it is proposed to use any heating medium other than steam or hot water, full particulars of the proposed arrangements are to be submitted for special consideration.

2.7.4 The heating pipes in contact with oil are to be of iron, steel, approved aluminium alloy or approved copper alloy, and, after being fitted on board, are to be tested by hydraulic pressure in accordance with the requirements of *Pt 5, Ch 12, 8.1 Hydraulic tests before installation on board*.

2.7.5 Where electric heating elements are fitted means are to be provided to ensure that all elements are submerged at all times when electric current is flowing and that their surface temperature cannot exceed 220°C.

2.8 Temperature indication

2.8.1 Tanks and heaters in which oil is heated are to be provided with suitable means for ascertaining the temperature of the oil. Where thermometers or temperature sensing devices are not fitted in blind pockets, a warning notice, in raised letters, is to be affixed adjacent to the fittings stating 'Do not remove unless tank/heater is drained'.

2.8.2 Controls are to be fitted to limit oil temperatures in oil storage and service tanks in accordance with *Pt 5, Ch 14, 2.1 Flash point 2.1.4* and in oil heaters to the maximum approved operating temperature, see *Pt 6, Ch 1 Control Engineering Systems*.

2.9 Precautions against fire

2.9.1 Fuel oil tanks and fuel oil filters are not to be situated immediately above boilers or other highly heated surfaces, see also *Pt 5, Ch 1, 4.5 Fire protection*.

2.9.2 Fuel oil pipes are not to be installed above or near high temperature equipment. Fuel oil pipes should also be installed and screened or otherwise suitably protected to avoid oil spray or oil leakages onto hot surfaces, into machinery air intakes, or other sources of ignition such as electrical equipment. Pipe joints are to be kept to a minimum, and where provided are to be of a type acceptable to LR. Pipes are to be led in well lit and readily visible positions, see also *Pt 5, Ch 2, 8 Piping*.

2.9.3 Pumps, filters and heaters are to be located to avoid oil spray or oil leakages onto hot surfaces or other sources of ignition, or onto rotating machinery parts. Where necessary, shielding is to be provided and the arrangements are to allow easy access for routine maintenance. The design of filter and strainer arrangements is to be such as to avoid the possibility of them being opened inadvertently when under pressure. This may be achieved by either mechanically preventing the pressurised filter

from being opened or by providing pressure gauges which clearly indicate which filter is under pressure. In either case, suitable means for pressure release are to be provided, with drain pipes led to a safe location.

2.9.4 The arrangement and location of short sounding pipes to oil tanks are to be in accordance with *Pt 5, Ch 13, 12.13 Short sounding pipes*. For alternative sounding arrangements, see *Pt 5, Ch 13, 12.11 Sounding arrangements*.

2.9.5 Water service pipes and hoses are to be fitted in order that the floor plates and tank top or shell plating in way of boilers, fuel oil apparatus or deep storage tanks in the engine and boiler spaces can at any time be flushed with sea-water.

2.9.6 So far as is practicable, the use of wood is to be avoided in the engine rooms, boiler rooms and tunnels of ships burning fuel oil.

2.9.7 Drip trays are to be fitted at the furnace mouths to intercept oil escaping from the burners, and under all other fuel oil appliances which are required to be opened up frequently for cleaning or adjustment.

2.9.8 Oil-tight drip trays of ample size having suitable drainage arrangements are to be provided at pipes, pumps, valves and other fittings where there is a possibility of leakage. Valves should be located in well lighted and readily visible positions. Drip trays will not be required where pumps, valves and other fittings are placed in special compartments either inside or outside the machinery space with approved overall drainage arrangements or for valves which are so positioned that any leakage will drain directly into the bilges, see *Pt 5, Ch 14, 2.9 Precautions against fire 2.9.2*.

2.9.9 Where drainage arrangements are provided from collected leakages, they are to be led to a suitable oil drain tank not forming part of an overflow system.

2.9.10 Separate fuel oil tanks are to be placed in an oil-tight spill tray of ample size having drainage arrangements leading to a drain tank of suitable size, see *Pt 5, Ch 14, 4.17 Separate fuel oil tanks*.

2.9.11 Where level switches are used below the tank top, they are to be contained in a steel enclosure or other enclosures which provide equivalent protection against fire.

2.10 Fuel oil contamination

2.10.1 The materials and/or their surface treatment used for the storage and distribution of fuel oil are to be selected such that they do not introduce contamination or modify the properties of the fuel. The use of copper or zinc compounds in fuel oil distribution and utilisation piping is not permitted except for small diameter pipes in low pressure systems, see *Pt 5, Ch 14, 4.6 Low pressure pipes 4.6.1*.

2.10.2 For prevention of ingress of water into fuel oil tanks via air pipes, see *Pt 5, Ch 13, 12.5 Termination of air pipes 12.5.4*.

2.10.3 The piping arrangements for fuel oil are to be separate and distinct from those intended for lubricating oil systems to prevent contamination of fuel oil by lubricating oil.

2.10.4 Piping arrangements or alternative means are to be provided to ensure that distillates (i.e. gas oils/diesel grades) are to be kept separate and distinct from residual grades, up to the service tanks required by *Pt 5, Ch 14, 4.18 Fuel oil service tanks*, in order to prevent cross-contamination. Cross-connection is permitted between separate arrangements in the event of failure of a designated item of equipment.

2.11 Tanks and cofferdams

2.11.1 Tanks containing fuel oil are to be separated from passenger, crew and baggage compartments by a gastight and watertight boundary or a cofferdam which is suitably ventilated and drained.

■ Cross-reference

For requirements regarding refrigerated cargo spaces in way of oil storage tanks, see *Pt 6, Ch 3, 4 Refrigeration plant, pipes, valves and fittings*.

■ *Section 3*

Fuel oil burning arrangements**3.1 Oil burning units**

3.1.1 All oil burning equipment is to be capable of operating at defined power/rating levels where specified by the Owner/Operator. Confirmation by the manufacturer of this capability is to be provided to LR including the specified power/rating parameters, and operating and maintenance regimes. *See also Pt 5, Ch 1, 3.1 Availability for operation 3.1.2.*

3.1.2 Where steam is required for the main propelling engines, or where steam or thermal oil is required for auxiliary machinery for essential services, or for heating of heavy fuel oil and is generated by burning fuel oil under pressure, there are to be not less than two oil burning units. For auxiliary boilers, a single oil burning unit may be accepted, provided that alternative means, such as an exhaust gas boiler or composite boiler, are available for supply of essential services. Where the oil burning unit is not of the monobloc type (i.e. separate register and oil supply unit), each oil burning unit is to comprise a pressure pump, suction filter, discharge filter and, when required, a heater.

3.1.3 In installations consisting of two or more oil burning units, the number, arrangement and capacity of such units is to be capable of supplying sufficient fuel to allow the steam to be generated or thermal oil heated, as applicable to provide essential services with any one unit out of action.

3.1.4 Unit pressure pumps are to be entirely separate from the feed, bilge or ballast systems.

3.1.5 In dual fuel oil burning systems for boilers which are primarily designed for operation with residual fuel oil grades, arrangements are to be such that atomising steam cannot be used in combination with distillate fuel oil grades where the burner arrangements have not been designed for such use.

3.1.6 In all dual fuel oil burning systems for boilers, the manufacturer of the combustion equipment is to ensure that the full system, including control and monitoring systems, is capable of continuous operation in all conditions for each fuel grade.

3.1.7 Whenever the fuel oil burning units are stopped, shut-off arrangements for fuel oil to the units are to be provided as follows:

- (a) If the supply fuel oil is under pressure during shut-off to oil burning units, duplicated shut-off valves in series are to be fitted. Arrangements are to be such to allow manual testing for leakage from each of the valves in the installed condition, the test arrangement is to be such to prevent inadvertent operation, and any discharges are to be led to a safe position to ensure that discharge of leakage oil does not present an ignition hazard.
- (b) If arrangements are such that fuel oil pressure is released through drainage during fuel oil shut-off to oil burning units, a single shut-off device may be accepted subject to approval by LR.

3.1.8 When combined air and fuel/steam/air combustion systems are used for multiple boiler installations, they are to be such that single boiler operation will not be adversely affected by the operation of another boiler system at any time.

3.1.9 Arrangements are to be such that furnace prepurging is completed prior to any burner ignition sequence. The purge time is to be based on a minimum of 4 air changes of the combustion chamber, furnace and uptake spaces. The purge timing is to take account of the air flow rate and the sequence is not to commence until all air registers and dampers, as applicable, are fully open and the forced draft fans are operating.

3.1.10 The effect of multiple light-off failures is to be assessed and the need to lock out further ignition sequences established. The manufacturer's recommended procedures are to be followed before further attempts to ignite the boiler are made. These procedures are to be displayed at the ignition control positions and included in the warning notice required by *Pt 5, Ch 14, 3.1 Oil burning units 3.1.11.*

3.1.11 Means are to be provided so that, in the event of flame failure, the fuel oil supply to the burner(s) is shut-off automatically, and an alarm is given, *see Pt 5, Ch 10, 18.3 Main, auxiliary and other boilers, Pt 5, Ch 14, 12.2 Thermal fluid heaters and Pt 5, Ch 14, 12.3 Incinerators, as applicable.*

3.1.12 It is to be demonstrated to the Surveyor's satisfaction during trials that burner shut-off times due to flame failure comply with the following requirements, and details of the procedures and means used to set this time interval are to be submitted for consideration:

- (a) The time interval at burner start up between the burner fuel oil valve(s) being opened and then closed in the event of flame failure is to be long enough to allow a stable flame to be established and detected under normal operational circumstances,

but is to be set to minimise the quantity of fuel oil delivered to the furnace and the possibility of subsequent damage as a result of unintended ignition.

- (b) The time interval between flame failure detection and closing of burner fuel oil valve(s) is to be long enough to prevent shutdown due to incorrect detection of a flame failure under normal operational circumstances, but is to be set to minimise the quantity of unburned fuel oil delivered to the furnace and the possibility of subsequent damage as a result of unintended ignition.

3.1.13 A warning notice is to be fitted in a prominent position at every oil burning unit local manual control station which specifies that burners operated with manual or local overrides in use are only to be ignited after sufficient purging of the furnace and of any additional precautions required when operating in this condition.

3.2 Gravity feed

3.2.1 In systems where oil is fed to the burners by gravity, duplex filters are to be fitted in the supply pipeline to the burners and so arranged that one filter can be opened up when the other is in use.

3.3 Starting-up unit

3.3.1 A starting-up fuel oil unit, including an auxiliary heater and hand pump, or other suitable starting-up device, which does not require power from shore, is to be provided.

3.3.2 Alternatively, where auxiliary machinery requiring compressed air or electric power is used to bring the boiler plant into operation, the arrangements for starting such machinery are to comply with *Pt 5, Ch 2, 9.1 Dead ship condition starting arrangements*.

3.4 Steam connections to burners

3.4.1 Where burners are provided with steam purging and/or atomising connections, the arrangements are to be such that fuel oil cannot find its way into the steam system in the event of valve leakage.

3.5 Burner arrangements

3.5.1 The burner arrangements are to be such that a burner cannot be withdrawn unless the fuel oil supply to that burner is shut off, and that the oil cannot be turned on unless the burner has been correctly coupled to the supply line.

3.6 Quick-closing valve

3.6.1 A quick-closing master valve is to be fitted to the oil supply to each boiler manifold, suitably located so that the valve can be readily operated in an emergency, either directly or by means of remote control, having regard to the machinery arrangements and location of controls.

3.7 Spill arrangements

3.7.1 Provision is to be made, by suitable non-return arrangements, to prevent oil from spill systems being returned to the burners when the oil supply to these burners has been shut off.

3.8 Alternately-fired furnaces

3.8.1 For alternately-fired furnaces of boilers using exhaust gases and fuel oil, the exhaust gas inlet pipe is to be provided with an isolating device and interlocking arrangements whereby fuel oil can only be supplied to the burners when the isolating device is closed to the boiler.

3.9 Fuel oil treatment for supply to main and auxiliary oil engines and gas turbines

3.9.1 A suitable fuel treatment plant that may include filtration, centrifuging and/or coalescing is to be provided to reduce the level of water and particulate contamination of the fuel oil to within the engine or gas turbine manufacturer's limits for inlet to the combustion system. The capacity and arrangements of the treatment plant is to be suitable for ensuring availability of treated fuel oil for the maximum continuous demand of the propulsion and electrical generating plant.

3.9.2 Two or more treatment systems are to be provided as part of the fuel treatment plant such that failure of one system will not render the other system(s) inoperative. Arrangements are to ensure that the failure of a treatment system will not interrupt the supply of clean fuel oil to oil engines or gas turbines used for propulsion and electrical generating purposes where treatment plant

is installed between fuel oil service tanks and the inlet to the combustion system. Any treatment equipment in the system is to be capable of being cleaned without interrupting the flow of treated fuel to supply the combustion system.

3.9.3 Centrifuges used for fuel oil treatment are to be type tested for their intended usage when installed on board a ship in accordance with a standard acceptable to LR.

3.9.4 Where heating of the fuel oil is required for the efficient functioning of the fuel oil treatment plant, a minimum of two heating units are to be provided. Each heating unit is to be of sufficient capacity to raise and maintain the required temperature of the fuel oil for the required delivery flow rate.

3.9.5 Heating units may be in circuit with separate treatment systems or provided with connections such that any heating unit can be connected to any treatment system.

3.9.6 Where heating of the fuel oil is required for combustion, not less than two pre-heaters are to be provided, each with sufficient capacity to raise the temperature of the fuel to provide a viscosity suitable for combustion.

3.9.7 Filters and/or coalescers are to be fitted in the fuel oil supply lines to each oil engine and gas turbine to ensure that only suitably filtered oil is fed to the combustion system. The arrangements are to be such that any unit can be cleaned without interrupting the supply of filtered oil to the combustion system.

3.10 Booster pumps

3.10.1 Where an fuel oil booster pump is fitted, which is essential to the operation of the main engine, a standby pump is to be provided.

3.10.2 The standby pump is to be connected ready for immediate use but where two or more main engines are fitted, each with its own pump, a complete spare pump may be accepted provided that it is readily accessible and can easily be installed.

3.11 Booster pumps when operating in emissions control areas

3.11.1 Ships intending to use Heavy Fuel Oil (HFO) or Marine Diesel Oil (MDO) when operating outside emissions control areas and marine fuels with a sulphur content not exceeding 0,1 per cent m/m and minimum viscosity of 2 cSt when operating inside emission control areas are to meet the requirements of *Pt 5, Ch 14, 3.11 Booster pumps when operating in emissions control areas 3.11.2* or *Pt 5, Ch 14, 3.11 Booster pumps when operating in emissions control areas 3.11.3*.

3.11.2 The booster pumps which are fitted in compliance with 3.10 are acceptable for use in emissions control areas where these pumps are each suitable for marine fuels with a sulphur content not exceeding 0,1 per cent m/m and minimum viscosity of 2 cSt operation at the required capacity for normal operation of propulsion machinery.

3.11.3 When the booster pumps which are fitted in compliance with *Pt 5, Ch 14, 3.10 Booster pumps* are suitable to operate on marine fuels with a sulphur content not exceeding 0,1 per cent m/m and minimum viscosity of 2 cSt, but one pump alone is not capable of delivering marine fuels with a sulphur content not exceeding 0,1 per cent m/m and minimum viscosity of 2 cSt at the required capacity, two booster pumps may operate in parallel to achieve the required capacity for normal operation of propulsion machinery. In this case, one additional (third) fuel oil pump is to be provided. The additional booster pump shall, when operating in parallel with one of the booster pumps in *Pt 5, Ch 14, 3.10 Booster pumps*, be suitable for and capable of delivering marine fuels with a sulphur content not exceeding 0,1 per cent m/m and minimum viscosity of 2 cSt at the required capacity for normal operation of the propulsion machinery.

3.12 Fuel valve cooling pumps

3.12.1 Where pumps are provided for fuel valve cooling, the arrangements are to be in accordance with *Pt 5, Ch 14, 3.10 Booster pumps*.

3.13 Oil-fired galleys

3.13.1 The fuel oil tank is to be located outside the galley and is to be fitted with approved means of filling and venting.

3.13.2 The fuel supply to the burners is to be controlled from a position which will always be accessible in the event of a fire occurring in the galley.

3.13.3 The galley is to be well ventilated.

3.13.4 When liquefied petroleum gas is used, bottles are to be stored on the open deck or in a well ventilated space which only opens to the open deck.

■ Section 4**Fuel oil pumps, pipes, fittings, tanks, etc.****4.1 Transfer pumps**

4.1.1 Where a power driven pump is necessary for transferring fuel oil, a standby pump is to be provided and connected ready for use, or, alternatively, emergency connections may be made to one of the unit pumps or to another suitable power driven pump.

4.2 Control of pumps

4.2.1 The power supply to all independently driven fuel oil transfer and pressure pumps is to be capable of being stopped from a position outside the space which will always be accessible in the event of fire occurring in the compartment in which they are situated, as well as from the compartment itself.

4.3 Relief valves on pumps

4.3.1 All pumps which are capable of developing a pressure exceeding the design pressure of the system are to be provided with relief valves. Each relief valve is to be in closed circuit, i.e. arranged to discharge back to the suction side of the pump and to effectively limit the pump discharge pressure to the design pressure of the system.

4.4 Pump connections

4.4.1 Valves or cocks are to be interposed between the pumps and the suction and discharge pipes, in order that any pump may be shut off for opening up and overhauling.

4.5 Pipes conveying oil

4.5.1 Pipes conveying oil under pressure are to be of seamless steel or other approved material having flanged or welded joints, and are to be placed in sight above the platform in well lighted and readily accessible parts of the machinery spaces. The number of flanged joints is to be kept to a minimum.

4.5.2 Where pipes convey heated oil under pressure the flanges are to be machined, and the jointing material, which is to be impervious to oil heated to 150°C, is to be the thinnest possible, so that flanges are practically metal to metal. The scantlings of the pipes and their flanges are to be suitable for a pressure of at least 13,7 bar (14 kgf/cm²) or for the design pressure, whichever is the greater.

4.5.3 The short joining lengths of pipes to the burners from the control valves at the boiler may have cone unions, provided these are of specially robust construction.

4.5.4 Flexible hoses of approved material and design may be used for the burner pipes, provided that spare lengths, complete with couplings, are carried on board.

4.5.5 For requirements relating to flexible hoses, see *Pt 5, Ch 12, 7 Flexible hoses*.

4.6 Low pressure pipes

4.6.1 Transfer, suction and other low pressure oil pipes and all pipes passing through oil storage tanks are to be made of cast iron or steel, having flanged joints suitable for a working pressure of not less than 6,9 bar (7 kgf/cm²). The flanges are to be machined and the jointing material is to be impervious to oil. Where the pipes are 25 mm bore or less, they may be of seamless copper or copper alloy, except those which pass through oil storage tanks. Oil pipes within the engine and boiler spaces are to be fitted where they can be readily inspected and repaired.

4.6.2 For requirements regarding bilge pipes in way of double bottom tanks and deep tanks, see *Pt 5, Ch 13, 7.9 Bilge pipes in way of double bottom tanks* and *Pt 5, Ch 13, 7.10 Bilge pipes in way of deep tanks*.

4.7 Valves and cocks

4.7.1 Valves, cocks and their pipe connections are to be so arranged that oil cannot be admitted into tanks which are not structurally suitable for the carriage of oil or into tanks which can be used for the carriage of fresh water.

4.7.2 All valves and cocks forming part of the fuel oil installation are to be capable of being controlled from readily accessible positions which, in the engine and boiler spaces, are to be above the working platform, see also *Pt 5, Ch 13, 2.3 Valves – Installation and control*.

4.7.3 Every fuel oil suction pipe from a double bottom tank is to be fitted with a valve or cock.

4.8 Valves on deep tanks and their control arrangements

4.8.1 Every fuel oil suction pipe from a storage, settling and daily service tank situated above the double bottom, and every fuel oil levelling pipe within the boiler room or engine room, is to be fitted with a valve or cock secured to the tank.

4.8.2 The valves and cocks mentioned in *Pt 5, Ch 14, 4.8 Valves on deep tanks and their control arrangements 4.8.1* are to be capable of being closed locally and from positions outside the space in which the tank is located. The remote controls are to be accessible in the event of fire occurring in the deep tank's space. Instructions for closing the valves or cocks are to be indicated at the valves and cocks and at the remote control positions.

4.8.3 The control for remote operation of the valve on the emergency generator fuel tank is to be in a separate location from the controls for the remote operation of other valves for tanks located in machinery spaces.

4.8.4 In the case of tanks of less than 500 litres capacity, consideration will be given to the omission of remote controls.

4.8.5 Every fuel oil suction pipe which is led into the engine and boiler spaces, from a tank situated above the double bottom outside these spaces, is to be fitted in the machinery space with a valve controlled as in *Pt 5, Ch 14, 4.8 Valves on deep tanks and their control arrangements 4.8.2*, except where the valve on the tank is already capable of being closed from an accessible position above the bulkhead deck.

4.8.6 Where the filling pipes to deep oil tanks are not connected to the tanks near the top, they are to be provided with non-return valves at the tanks or with valves or cocks fitted and controlled as in *Pt 5, Ch 14, 4.8 Valves on deep tanks and their control arrangements 4.8.2*.

4.9 Water drainage from settling tanks

4.9.1 Settling tanks are to be provided with means for draining water from the bottom of the tanks.

4.9.2 If settling tanks are not provided, the fuel oil bunkers or daily service tanks are to be fitted with water drains.

4.9.3 Open drains for removing the water from oil tanks are to be fitted with valves or cocks of self-closing type, and suitable provision is to be made for collecting the oily discharge.

4.10 Relief valves on oil heaters

4.10.1 Relief valves are to be fitted on the oil side of heaters and are to be adjusted to operate at a pressure of 3,4 bar (3,5 kgf/cm²) above that of the supply pump relief valve, see *Pt 5, Ch 14, 4.3 Relief valves on pumps*. The discharge from the relief valves is to be led to a safe position.

4.11 Filling arrangements

4.11.1 Filling stations are to be isolated from other spaces and are to be efficiently drained and ventilated.

4.11.2 Provision is to be made against over-pressure in the filling pipelines, and any relief valve fitted for this purpose is to discharge to an overflow tank or other safe position.

4.12 Transfer arrangements – Passenger ships

4.12.1 In passenger ships, provision is to be made for the transfer of fuel oil from any fuel oil storage or settling tank to any other fuel oil storage or settling tank in the event of fire or damage.

4.13 Alternative carriage of fuel oil and water ballast

4.13.1 Where it is intended to carry fuel oil and water ballast in the same compartments alternatively, the valves or cocks connecting the suction pipes of these compartments with the ballast pump and those connecting them with the fuel oil transfer pump are to be so arranged that the oil may be pumped from any one compartment by the fuel oil pump at the same time as the ballast pump is being used on any other compartment. In passenger ships the arrangement will require to be specially approved.

4.13.2 Where settling or service tanks are fitted, each having a capacity sufficient to permit 12 hours normal service without replenishment, the above requirement may be dispensed with.

4.13.3 Attention is drawn to the statutory regulations issued by National Authorities in connection with the *Annex I of MARPOL 73/78 Regulations for the Prevention of Pollution by Oil*

4.14 Deep tanks for the alternative carriage of oil, water ballast or dry cargo

4.14.1 In the case of deep tanks which can be used for the carriage of fuel oil, cargo oil, water ballast or dry cargo, provision is to be made for blank flanging the oil and water ballast filling and suction pipes, also the steam heating coils if retained in place, when the tank is used for dry cargo, and for blank flanging the bilge suction pipes when the tanks are used for oil or water ballast.

4.14.2 If the deep tanks are connected to an overflow system, the arrangements are to be such that liquid or vapour from other tanks cannot enter the deep tanks when dry cargo is carried in them.

4.15 Separation of cargo oils from fuel oil

4.15.1 Pipes conveying vegetable oils or similar cargo oils are not to be led through fuel oil tanks, nor are fuel oil pipes to be led through tanks containing these cargo oils. For requirements regarding provision of cofferdams between oil and water tanks, see *Pt 3, Ch 3, 4.7 Protection of tanks carrying fuel oil, lubricating oil, vegetable or similar oils*.

4.16 Fresh water piping

4.16.1 Pipes in connection with compartments used for storing fresh water are to be separate and distinct from any pipes which may be used for oil or oily water, and are not to be led through tanks which contain oil, nor are oil pipes to be led through fresh water tanks.

4.17 Separate fuel oil tanks

4.17.1 Where separate fuel oil tanks are permitted, their construction is to be in accordance with the requirements of *Pt 5, Ch 14, 4.17 Separate fuel oil tanks 4.17.2, see also SOLAS 1974 as amended Reg.II-2/B4. 2.2.3 Oil fuel tanks*.

4.17.2 In general, the minimum thickness of the plating of service, settling and other oil tanks, where they do not form part of the structure of the ship, is to be 5 mm, but in the case of very small tanks, the minimum thickness may be 3 mm.

4.17.3 For rectangular steel tanks of welded construction, the plate thicknesses are to be not less than those indicated in *Table 14.4.1 Plate thickness of separate fuel oil tanks*. The stiffeners are to be of approved dimensions.

Table 14.4.1 Plate thickness of separate fuel oil tanks

Thickness of plate, mm	Head from bottom of tank to top of overflow pipe, metres				
	2,5	3,0	3,7	4,3	4,9
Breadth of panel, mm					
5	585	525	—	—	—
6	725	645	590	—	—
7	860	770	700	650	—
8	1000	900	820	750	700
10	1280	1140	1040	960	900

4.17.4 The dimension given in *Table 14.4.1 Plate thickness of separate fuel oil tanks* for the breadth of the panel is the maximum distance allowable between continuous lines of support, which may be stiffeners, wash-plates or the boundary of the tank.

4.17.5 Where necessary, stiffeners are to be provided, and if the length of the stiffener exceeds twice the breadth of the panel, transverse stiffeners are also to be fitted, or, alternatively, tie bars are to be provided between stiffeners on opposite sides of the tank.

4.17.6 On completion, the tanks are to be tested by a head of water equal to the maximum to which the tanks may be subjected, but not less than 2,5 m above the crown of the tank.

4.18 Fuel oil service tanks

- 4.18.1 A fuel oil service tank is a fuel oil tank which contains only the required quality of fuel ready for immediate use.
- 4.18.2 Two fuel oil service tanks, for each type of fuel used on board, necessary for propulsion and generator systems, are to be provided. Each tank is to have a capacity for at least eight hours' operation, at sea, at maximum continuous rating of the propulsion plant and/or generating plant associated with that tank.
- 4.18.3 The arrangement of fuel oil service tanks is to be such that one tank can continue to supply fuel oil when the other is being cleaned or opened up for repair.
- 4.18.4 For ships of less than 500 gross tonnage, the capacity of each fuel oil service tank required by 4.18.2 may be less than for eight hours operation, where the class notation includes a service restriction.

4.19 Arrangements for fuels with a flash point between 43°C and 60°C

- 4.19.1 Fuel oil tanks other than those in double bottom compartments shall be located outside 'Category A' machinery spaces, *see also Pt 3, Ch 3, 4.7 Protection of tanks carrying fuel oil, lubricating oil, vegetable or similar oils.*
- 4.19.2 Provisions are to be made for the measurement of fuel oil temperature at the pump suction pipe.
- 4.19.3 Stop valves are to be provided at the inlet and outlet side of fuel oil strainers.
- 4.19.4 Pipe joints shall be either welded or spherical type union joints.
-

**■ Section 5
Steam piping systems****5.1 Provision for expansion**

- 5.1.1 In all steam piping systems, provision is to be made for expansion and contraction to take place without unduly straining the pipes.
- 5.1.2 Where expansion pieces are used, particulars are to be submitted.
- 5.1.3 For installation requirements regarding expansion pieces, *see Pt 5, Ch 13, 2.7 Provision for expansion.*

5.2 Drainage

- 5.2.1 The slope of the pipes and the number and position of the drain valves or cocks are to be such that water can be efficiently drained from any portion of the steam piping system when the ship is in normal trim and is either upright or has a list of up to 5°.
- 5.2.2 Arrangements are to be made for ready access to the drain valves or cocks.
- 5.2.3 For the drainage of boiler and exhaust gas economiser safety valves, *see Pt 5, Ch 10, 15.2 Safety valves 15.2.8.*

5.3 Soot cleaning drains

- 5.3.1 The capacity of the drains from exhaust gas economisers/boilers is to be sufficient to remove all wash water or condensate generated by installed washing systems and arrangements are to be such that engines and turbochargers are protected from wash water or condensate drainage from the washing system.
- 5.3.2 Adequate arrangements are to be made for the collection and disposal of the waste water generated during periodic water washing of the exhaust gas economiser/boiler. Details are to be submitted for approval.

5.4 Pipes in way of holds

- 5.4.1 In general, steam pipes are not to be led through spaces which may be used for cargo, but where it is impracticable to avoid this arrangement, plans are to be submitted for consideration. The pipes are to be efficiently secured and insulated, and well protected from mechanical damage. Pipe joints are to be as few as practicable and preferably butt welded.
- 5.4.2 If these pipes are led through shaft tunnels, pipe tunnels in way of cargo holds or through duct keels, they are to be efficiently secured and insulated.
-

5.5 Reduced pressure lines

5.5.1 Pipelines which are situated on the low pressure side of reducing valves, and which are not designed to withstand the full pressure at the source of supply, are to be fitted with pressure gauges and with relief valves having sufficient discharge capacity to protect the piping against excessive pressure.

5.6 Steam for fire-extinguishing in cargo holds

5.6.1 Where steam is used for fire-extinguishing in cargo holds provision is to be made to prevent damage to cargo by leakage of steam or by drip.

5.6.2 Details of the proposed precautionary measures are to be submitted.

■ **Cross-reference**

For steam heating arrangements for fuel oil, cargo oil or lubricating oil, see *Pt 5, Ch 14, 2.7 Heating arrangements*.

■ *Section 6*
Boiler feed water, condensate and thermal fluid circulation systems

6.1 Feed water piping

6.1.1 Two separate means of feed are to be provided for all main and auxiliary boilers which are required for essential services. In the case of steam/steam generators, one means of feed will be accepted provided steam for essential services is available simultaneously from another source.

6.2 Feed and circulation pumps

6.2.1 Two or more feed pumps are to be provided of sufficient capacity to supply the boilers under full load conditions with any one pump out of action.

6.2.2 Feed pumps may be worked from the main engines or may be independently driven, but at least one of the pumps required in *Pt 5, Ch 14, 6.2 Feed and circulation pumps 6.2.1* is to be independently driven.

6.2.3 In twin screw ships in which there is only one independent feed pump, each main engine is to be fitted with a feed pump. Where all the feed pumps are independently driven, the pumps are to be connected to deal with the condensate from both engines or from either engine.

6.2.4 Independent feed pumps required for feeding the main boilers are to be fitted with automatic regulators for controlling their output.

6.2.5 The arrangement of forced water/thermal fluid circulation pumps for exhaust gas economisers/boilers/thermal heaters is to be such that where required, the flow through the exhaust gas economiser/boiler/thermal heater is to be established prior to engine start up. Where applicable, provision is to be made to allow for operation in the dry condition.

6.2.6 The forced circulation flow required by *Pt 5, Ch 14, 6.2 Feed and circulation pumps 6.2.5* is to be maintained on completion of engine shutdown for a sufficient duration in accordance with the exhaust gas economiser/boiler/thermal heater manufacturer's instructions. Details of arrangements are to be submitted for approval.

6.2.7 Where arrangements are such that exhaust gas economisers/boilers/thermal heaters require forced water/thermal fluid circulation, standby pumps are to be fitted, see *Pt 5, Ch 4, 8.8 Unattended machinery 8.8.3*.

6.3 Harbour feed pumps

6.3.1 Where main-engine driven feed pumps are fitted and there is only one independent feed pump, a harbour feed pump or an injector is to be fitted to provide the second means of feed to the boilers which are in use when the main engines are not working. This requirement need not be complied with in the case of trawlers and fishing vessels.

6.3.2 The harbour feed pump required by *Pt 5, Ch 14, 6.3 Harbour feed pumps 6.3.1* may be used for general service, provided that it is not connected to tanks containing oil, or to tanks, cofferdams and bilges which may contain oily water.

6.3.3 The valves on the suction pipes from the hotwell or condenser and the feed drain tank or filter are to be of the non-return type.

6.4 Condensate pumps

6.4.1 Two or more extraction pumps are to be provided for dealing with the condensate from the main and auxiliary condensers, at least one of which is to be independently driven. Where one of the independent feed pumps is fitted with direct suction from the condensers and a discharge to the feed tank, it may be accepted for this purpose.

6.5 Valves and cocks

6.5.1 Feed and condensate pumps are to be provided with valves or cocks, interposed between the pumps and the suction and the discharge pipes, so that any pump may be opened up for overhaul while the others continue in operation.

6.6 Reserve feed water

6.6.1 All ships fitted with boilers are to be provided with storage space for reserve feed water, the structural and piping arrangements being such that this water cannot be contaminated by oil or oily water, see *Pt 3, Ch 3, 4.7 Protection of tanks carrying fuel oil, lubricating oil, vegetable or similar oils* for structural arrangements.

6.6.2 For main boilers, one or more evaporators, of adequate capacity, are also to be provided.

■ **Cross-reference**

For feed water level regulators for water tube boilers, see *Pt 5, Ch 10, 16.8 Feed check valves and water level regulators*.

■ *Section 7* **Engine cooling water systems**

7.1 Main supply

7.1.1 Provision is to be made for an adequate supply of cooling water to the main propelling machinery and essential auxiliary engines, also to the lubricating oil and fresh water coolers and air coolers for electric propelling machinery, where these coolers are fitted. The cooling water pump(s) may be worked from the engines or be driven independently.

7.1.2 In the case of main steam turbine installations, a sea inlet scoop arrangement may replace the main sea-water circulating pump, subject to the conditions stated in *Pt 5, Ch 14, 7.2 Standby supply 7.2.2*.

7.2 Standby supply

7.2.1 Provision is also to be made for a separate supply of cooling water from a suitable independent pump of adequate capacity.

7.2.2 The following arrangements are acceptable depending on the purpose for which the cooling water is intended:

- (a) Where only one main engine is fitted, the standby pump is to be connected ready for immediate use.
- (b) Where more than one main engine is fitted, each with its own pump, a complete spare pump of each type may be accepted.
- (c) Where a sea inlet scoop arrangement is fitted, and there is only one independent condenser circulating pump, a further pump, or a connection to the largest available pump suitable for circulation duties, is to be fitted to provide the second means of circulation when the ship is manoeuvring. The pump is to be connected ready for immediate use.
- (d) Where fresh water cooling is employed for main and/or auxiliary engines, a standby fresh water pump need not be fitted if there are suitable emergency connections from a salt water system.

- (e) Where each auxiliary is fitted with a cooling water pump, standby means of cooling need not be provided. Where, however, a group of auxiliaries is supplied with cooling water from a common system, a standby cooling water pump is to be provided for this system. This pump is to be connected ready for immediate use and may be a suitable general service pump.

7.3 Selection of standby pumps

7.3.1 When selecting a pump for standby purposes, consideration is to be given to the maximum pressure which it can develop if the overboard discharge valve is partly or fully closed and, when necessary, condenser doors, water boxes, etc. are to be protected by an approved device against inadvertent over-pressure. See *Pt 5, Ch 3, 7.3 Hydraulic tests* for the hydraulic test pressure which condensers are required to withstand.

7.4 Relief valves on main cooling water pumps

7.4.1 Where cooling water pumps can develop a pressure head greater than the design pressure of the system, they are to be provided with relief valves on the pump discharge to effectively limit the pump discharge pressure to the design pressure of the system. For location of relief valves see *Pt 5, Ch 13, 7.8 Location of fittings*.

7.5 Sea inlets

7.5.1 Not less than two sea inlets are to be provided for the pumps supplying the sea-water cooling system, one for the main pump and one for the standby pump. Alternatively, the sea inlets may be connected to a suction line available to main and standby pumps.

7.5.2 Where standby pumps are not connected ready for immediate use, see *Pt 5, Ch 14, 7.2 Standby supply 7.2.2*, the main pump is to be connected to both sea inlets.

7.5.3 Cooling water pump sea inlets are to be low inlets and one of them may be the ballast pump or general service pump sea inlet.

7.5.4 The auxiliary cooling water sea inlets are preferably to be located one on each side of the ship.

7.6 Strainers

7.6.1 Where sea-water is used for the direct cooling of the main engines and essential auxiliary engines, the cooling water suction pipes are to be provided with strainers which can be cleaned without interruption to the cooling water supply.

■ Cross-reference

For guidance on metal pipes for water services, see *Pt 5, Ch 12, 11 Appendix - Guidance notes on metal pipes for water services*.

■ Section 8 Lubricating oil systems

8.1 General requirements

8.1.1 The arrangements for storage, distribution and utilisation of lubricating oils are to comply with the requirements of this Section.

8.2 Pumps

8.2.1 Where lubricating oil for the main engine(s) is circulated under pressure, a standby lubricating oil pump is to be provided where the following conditions apply:

- (a) The lubricating oil pump is independently driven and the total output of the main engine(s) exceeds 370 kW(500 shp).
- (b) One main engine with its own pump is fitted and the output of the engine exceeds 370 kW (500 shp).

(c) More than one main engine each with its own lubricating oil pump is fitted and the output of each engine exceeds 370 kW (500 shp).

8.2.2 The standby pump is to be of sufficient capacity to maintain the supply of oil for normal conditions with any one pump out of action. The pump is to be fitted and connected ready for immediate use, except that where the conditions referred to in *Pt 5, Ch 14, 8.2 Pumps 8.2.1* apply a complete spare pump may be accepted. In all cases satisfactory lubrication of the engines is to be ensured while starting and manoeuvring.

8.2.3 Similar provisions to those of *Pt 5, Ch 14, 8.2 Pumps 8.2.1* and *Pt 5, Ch 14, 8.2 Pumps 8.2.2* are to be made where separate lubricating oil systems are employed for piston cooling, reduction gears, oil operated couplings and controllable pitch propellers, unless approved alternative arrangements are provided.

8.2.4 Independently driven pumps of rotary type are to be fitted with a non-return valve on the discharge side of the pump.

8.3 Control of pumps

8.3.1 The power supply to all independently driven lubricating oil transfer and pressure pumps is to be capable of being stopped from a position outside the space, which will always be accessible in the event of fire occurring in the compartment in which they are situated, as well as from the compartment itself.

8.4 Relief valves on pumps

8.4.1 All lubricating oil pumps which are capable of developing a pressure exceeding the design pressure of the system are to be provided with relief valves or equivalent. Each relief valve is to be in closed circuit, i.e. arranged to discharge back to the suction side of the pump, thereby limiting the pump discharge pressure to the design pressure of the system.

8.4.2 Where centrifugal type lubricating oil pumps are fitted, pressure relief valves will not be required, provided that pipes, valves and fittings are suitable for the greater of the design pressure or pump non-delivery pressure.

8.5 Emergency supply for propulsion turbines and propulsion turbo-generators

8.5.1 A suitable emergency supply of lubricating oil is to be arranged to come automatically into use in the event of a failure of the supply from the pump.

8.5.2 The emergency supply may be obtained from a gravity tank containing sufficient oil to maintain adequate lubrication for not less than six minutes, and, in the case of propulsion turbo-generators, until the unloaded turbine comes to rest from its maximum rated running speed.

8.5.3 Alternatively, the supply may be provided by the standby pump or by an emergency pump. These pumps are to be so arranged that their availability is not affected by a failure in the power supply.

8.5.4 For automatic shutdown arrangements of main turbines in the event of failure of the lubrication system, see *Pt 5, Ch 3, 5.1 Lubricating oil failure* and *Pt 5, Ch 4, 8 Control, alarm and safety systems*.

8.6 Maintenance of bearing lubrication

8.6.1 The arrangements for lubricating bearings and for draining crankcase and other oil sumps of main and auxiliary engines, gearcases, electric generators, motors, and other running machinery are to be so designed that lubrication will remain efficient with the ship inclined under the conditions as shown in *Pt 5, Ch 1, 3.7 Inclination of ship*.

8.6.2 For details of the requirements relating to the lubrication of bearings of electric generators and motors, see *Pt 6, Ch 2, 1.10 Inclination of ship* and *Pt 5, Ch 14, 8 Lubricating oil systems*.

8.7 Filters

8.7.1 Where the lubricating oil for main propelling engines is circulated under pressure, provision is to be made for the efficient filtration of the oil. The filters are to be capable of being cleaned without stopping the engine or reducing the supply of filtered oil to the engine. Proposals for an automatic by-pass for emergency purposes in high speed engines are to be submitted for special consideration.

8.7.2 In the case of propulsion turbines and their gears, arrangements are to be made for the lubricating oil to pass through magnetic strainers and fine filters. Generally, the openings in the filter elements are to be not coarser than required by the manufacturer of the turbines, especially for the supply to turbine thrust bearings.

8.7.3 Centrifuges used for lubricating oil treatment are to be type tested for a ship in accordance with a national or international standard acceptable to LR.

8.8 Filling arrangements

8.8.1 Filling stations are to be isolated from other spaces and are to be efficiently drained and ventilated.

8.9 Cleanliness of pipes and fittings

8.9.1 Extreme care is to be taken to ensure that lubricating oil pipes and fittings, before installation, are free from scale, sand, metal particles and other foreign matter.

8.10 Pipes conveying oil

8.10.1 Pipes conveying lubricating oil under pressure are to be of seamless steel or other approved material having flanged or welded joints, and are to be placed in sight above the platform in well lit and readily accessible parts of the machinery spaces. The number of flanged joints is to be kept to a minimum.

8.10.2 For requirements relating to flexible hoses, see *Pt 5, Ch 12, 7 Flexible hoses*.

8.11 Lubricating oil drain tank

8.11.1 Where an engine lubricating oil drain tank extends to the bottom shell plating in ships that are required to be provided with a double bottom, a shut-off valve is to be fitted in the drainpipe between the engine casing and the double bottom tank. This valve is to be capable of being closed from an accessible position above the level of the lower platform.

8.12 Lubricating oil contamination

8.12.1 The materials used in the storage and distribution of lubricating oil are to be selected such that they do not introduce contaminants or modify the properties of the oil. The use of cadmium or zinc in lubricating oil systems where they may normally come into contact with the oil is not permitted.

8.12.2 Arrangements are to be made for each forced lubrication system, renovation system, ready to use tank(s) and their associated rundown lines to drain tanks to be flushed after system installation and prior to running of machinery. The flushing arrangements are to be in accordance with the equipment manufacturer's procedures and recommendations.

8.12.3 For prevention of ingress of water into lubricating oil tanks via air pipes, see *Pt 5, Ch 13, 12.5 Termination of air pipes 12.5.4*.

8.12.4 The design and construction of engine and gear box piping arrangements are to prevent contamination of engine lubricating oil systems by leakage of cooling water or from bilge water where engines or gearboxes are partly installed below the lower platform. Where flexibility is required to accommodate movement between the engine and sump tank, any flexible joint assembly is to be of an approved type suitable for its intended application.

8.12.5 Where there is a permanently attached oil filling pipe and cap provided for an engine or other item of machinery, provision is to be made for the topping up oil to safely pass through a suitable strainer to prevent unwanted matter getting into the lubricating oil system. The caps are to be capable of being secured in the closed position.

8.12.6 Sampling points are to be provided that enable samples of lubricating oil to be taken in a safe manner. The sampling arrangements are to have the capability to provide samples when machinery is running and are to be provided with valves and cocks of the self-closing type and located in positions as far removed as possible from any heated surface or electrical equipment.

8.13 Deep tank valves and their control arrangements

8.13.1 The requirements for remote operation on valves on deep tank suction pipes may be waived where the valves are closed during normal operation.

8.13.2 Remotely operated valves on lubricating oil deep tank suction pipes should not be of the quick-closing type where inadvertent use would endanger the safe operation of the main propulsion and essential auxiliary machinery.

8.13.3 Every lubricating oil suction pipe from a storage, settling and service tank situated above the double bottom, and every oil levelling pipe within the engine room, is to be fitted with a valve or cock secured to the tank.

8.13.4 Valves and cocks are to be capable of being closed locally and from positions outside the space in which the tank is located. The remote controls are to be accessible in the event of fire occurring in the deep tank's space. Instructions for closing the valves or cocks are to be indicated at the valves and cocks and at the remote control positions.

8.13.5 In the case of tanks of less than 500 litres, capacity, consideration will be given to the omission of remote controls.

8.13.6 Every lubricating oil suction pipe which is led into the engine space from a tank situated above the double bottom outside this space is to be fitted in the machinery space with a valve controlled as in *Pt 5, Ch 14, 8.13 Deep tank valves and their control arrangements 8.13.4*, except where the valve on the tank is already capable of being closed from an accessible position above the bulkhead deck.

8.13.7 Where the filling pipes to deep lubricating oil tanks are not connected to the tanks near the top, they are to be provided with non-return valves at the tanks or with valves or cocks, fitted and controlled as in *Pt 5, Ch 14, 8.13 Deep tank valves and their control arrangements 8.13.4*.

8.14 Separate oil tanks

8.14.1 On completion, the tanks are to be tested by a head of water equal to the maximum to which the tanks may be subjected.

8.15 Precautions against fire

8.15.1 Lubricating oil tanks and filters are not to be situated immediately above boilers or other highly heated surfaces.

8.15.2 Lubricating oil pipes are not to be installed above or near high-temperature equipment. Lubricating oil pipes should also be installed and screened or otherwise suitably protected, to avoid oil spray or oil leakages on to hot surfaces, into machinery air intakes, or other sources of ignition such as electrical equipment. Pipe joints are to be kept to a minimum and where provided are to be of a type acceptable to LR. Pipes are to be led in well lit and readily visible positions.

8.15.3 Pumps, filters and heaters are to be located to avoid lubricating oil spray or leakage on to hot surfaces or other sources of ignition, or on to rotating machinery parts. Where necessary, shielding is to be provided and the arrangements are to allow easy access for routine maintenance. The design of filter and strainer arrangements is to be such as to avoid the possibility of them being opened inadvertently when under pressure. This may be achieved either by mechanically preventing the pressurised filter from being opened or by providing pressure gauges which clearly indicate which filter is under pressure. In either case, suitable means for pressure release are to be provided, with drain pipes led to a safe location.



Cross-references

For air, sounding pipes and gauge glasses, see *Pt 5, Ch 13, 11 Ballast system*.

For separation of lubricating oil tanks from fuel tanks, see *Pt 3, Ch 3, 4.7 Protection of tanks carrying fuel oil, lubricating oil, vegetable or similar oils*.



Section 9 **Hydraulic systems**

9.1 General

9.1.1 The requirements of this Section are applicable to flammable oils employed under pressure in power transmission, control, actuating and heating systems, and hydraulic media in systems which are providing essential services.

9.1.2 The arrangements for storage, distribution and utilisation of hydraulic and flammable oils employed in the systems defined in *Pt 5, Ch 14, 9.1 General 9.1.1* are to comply with the requirements of this Section.

9.2 System arrangements

9.2.1 Hydraulic fluids are to be suitable for the intended purpose under all operating service conditions.

9.2.2 Materials used for all parts of hydraulic seals are to be compatible with the working fluid at the appropriate working temperature and pressure.

9.2.3 Provision is to be made for hand operation of the systems in an emergency, unless an acceptable alternative is available.

9.2.4 Where hydraulic securing arrangements are applied, the system is to be capable of being locked in the closed position so that in the event of hydraulic system failure the securing arrangements will remain locked.

9.2.5 Where pilot operated non-return valves are fitted to hydraulic cylinders for locking purposes, the valves are to be connected directly to the actuating cylinder(s) without intermediate pipes or hoses.

9.2.6 Hydraulic circuits for securing and locking of bow, inner, stern or shell doors are to be arranged such that they are isolated from other hydraulic circuits when securing and locking devices are in the closed position. For requirements relating to hydraulic steering gear arrangements see *Pt 5, Ch 19, 3 Construction and design*.

9.2.7 Suitable oil collecting arrangements for leaks shall be fitted below hydraulic valves and cylinders.

9.3 Relief valves on pumps

9.3.1 All pumps which are capable of developing a pressure exceeding the design pressure of the system are to be provided with relief valves. Each relief valve is to be in closed circuit, i.e. arranged to discharge back to the suction side of the pump and effectively to limit the pump discharge pressure to the design pressure of the system.

9.4 Pipes conveying oil

9.4.1 Pipes conveying hydraulic oil under pressure are to be of seamless steel or other approved material having flanged or welded joints, and are to be placed in sight above the platform in well lit and readily accessible parts of the machinery spaces. The number of flanged joints is to be kept to a minimum.

9.4.2 For requirements relating to flexible hoses, see *Pt 5, Ch 12, 7 Flexible hoses*.

9.5 Filling arrangements

9.5.1 Filling stations are to be isolated from other spaces and are to be efficiently drained and ventilated.

9.6 Separate oil tanks

9.6.1 On completion, the tanks are to be tested by a head of water equal to the maximum to which the tanks may be subjected.

9.7 Precaution against fire

9.7.1 Hydraulic oil tanks and filters are not to be situated immediately above boilers or other highly heated surfaces.

9.7.2 Hydraulic oil pipes are not to be installed above or near high-temperature equipment. Hydraulic oil pipes should also be installed and screened or otherwise suitably protected, to avoid oil spray or oil leakages on to hot surfaces, into machinery air intakes, or other sources of ignition such as electrical equipment. Pipe joints are to be kept to a minimum and where provided are to be of a type acceptable to LR. Pipes are to be led in well lit and readily visible positions.

9.7.3 Pumps, filters and heaters are to be located to avoid hydraulic oil spray or leakage on to hot surfaces or other sources of ignition or on to rotating machinery parts. Where necessary, shielding is to be provided and the arrangements are to allow easy access for routine maintenance. The design of filter and strainer arrangements is to be such as to avoid the possibility of them being opened inadvertently when under pressure. This may be achieved either by mechanically preventing the pressurised filter from being opened or by providing pressure gauges which clearly indicate which filter is under pressure. In either case, suitable means for pressure release are to be provided, with drain pipes led to a safe location.

■ Section 10**Low pressure compressed air systems****10.1 General**

10.1.1 The requirements of this Section are applicable to low pressure (LP) compressed air systems intended for essential pneumatic control and instrumentation purposes. The documentation required by *Pt 5, Ch 13, 1.3 Plans and particulars 1.3.1* is to provide information to demonstrate compliance with *Pt 5, Ch 14, 10.1 General 10.1.2*.

10.1.2 Low pressure compressed air systems are to produce and distribute cooled compressed air throughout the ship to supply all pneumatic control and instrumentation systems where the air pressure requirements are typically 3 to 10 bar. LP compressed air systems may include air compressors, oil/water separators, filters, dryers, distribution lines and air receivers.

10.1.3 The design of LP compressed air systems is to be capable of providing a continuous flow of air to meet the demands of all essential services under all ambient conditions. This demand may include the use of intermittently used equipment that is part of the ship's equipment, such as power tools for machinery maintenance, testing equipment and line cleaning. Compressed air systems used for diesel engine or gas turbine starting are to comply with the requirements of *Pt 5, Ch 2, 13 Air compressors* and *Pt 5, Ch 4, 6 Starting arrangements* as applicable.

10.1.4 User equipment requirements for the quality of compressed air in terms of dewpoint (dryness), oil content and solid particle count are to be recognised in the selection and configuration of compressors, equipment, filters and dryers which are included in the system.

10.1.5 Configuration arrangements of LP compressed air systems may consist of:

- (a) Dedicated LP air compressors and LP air receivers with a distribution system for LP users; or
- (b) Supply from the starting air system to dedicated air pressure reducing valves/cross-over stations feeding into a distribution system for LP users.

10.2 Compressors and reducing valves/stations

10.2.1 Where LP air is not derived from the starting air system, at least two LP air compressors are to be provided. The output of any one compressor is to match the total demand of all essential users. The system is to be arranged for auto-start of the compressors and means are to be provided to indicate if any compressor is operating longer and more frequently than the manufacturer's recommended operating periods.

10.2.2 If only one LP air compressor is to be provided, a cross connection to the starting air system is to be made via a reducing valve/cross-connection station.

10.2.3 Where LP air is derived only from the starting air system, at least two means of supplying air to the LP air system are to be provided. Each of the two means of supplying air is to have sufficient capability of supplying the total demand on the LP air system with one of the means out of action.

10.2.4 Where the starting air system is fitted with an auxiliary compressor it is to be capable of continuous running and to be capable of maintaining the stored capacity of starting compressed air in the air receivers as required by *Pt 5, Ch 2, 13 Air compressors* and *Pt 5, Ch 4, 6 Starting arrangements* whilst also supplying essential LP services.

10.2.5 Where the starting air system is designed to maintain sufficient compressed air for LP services and engine starting arrangements, an additional auxiliary compressor will not be required.

10.3 Air receivers

10.3.1 The LP air system and any associated air receivers are to be configured to provide sufficient stored energy to supply LP compressed air without the pressure in the system falling below a level that is insufficient for the operation of all essential users. *See also Pt 6, Ch 1, 2.5 Control systems, general requirements 2.5.7.*

10.3.2 All air receivers are to comply with the requirements of *Pt 5, Ch 11 Other Pressure Vessels* as applicable.

10.3.3 Stop valves on air receivers are to permit slow opening to avoid sudden pressure rises in the piping system.

10.4 Distribution system

10.4.1 Drain pots with drain valves are to be provided throughout the distribution system at all low points.

10.4.2 Pipelines that are situated on the low pressure side of reducing valves/stations and that are not designed to withstand the full pressure of the source supply, are to be provided with pressure gauges and with relief valves having sufficient capacity to protect the piping against excessive pressure.

10.4.3 In-line filters capable of being cleaned/changed without interrupting the flow of filtered air are to be fitted in the system.

10.5 Pneumatic remote control valves

10.5.1 Where valves, which are required by the Rules to be capable of being closed from outside a machinery space, have pneumatic closing arrangements, a dedicated air receiver is to be fitted to supply compressed air to the valves. This air receiver is to be located outside the machinery space.

10.5.2 The air receiver is to be maintained fully charged from the main LP air system via a non-return valve located at the air receiver inlet which is to be locked in the open position.

10.5.3 In the case of passenger ships, a permanently attached hand-operated air compressor capable of charging the air receiver is to be provided in the space in which the air receiver is located.

10.5.4 The capacity of the air receiver is to be sufficient to operate all valves and any other essential supplies such as ventilation flaps without replenishment.

10.6 Control arrangements

10.6.1 The control, alarm and monitoring systems are to comply with *Pt 6, Ch 1 Control Engineering Systems*.

■ Section 11 **Multi-engined ships**

11.1 General

11.1.1 This Section is applicable to ships of less than 500 gross tons and which are not required to comply with the *SOLAS - International Convention for the Safety of Life at Sea*, as amended (SOLAS 74), and that have multi-engine installations for propulsion purposes.

11.1.2 For vessels in which the propulsion systems are independent and the propulsion system prime movers are also fully independent of each other such that in the event of the failure of one of the sources of propulsion power the vessels will retain the capability of safely manoeuvring under all conditions of service, the following may not be required:

- (a) Spare fuel oil booster pump stipulated in *Pt 5, Ch 14, 3.10 Booster pumps 3.10.2*.
- (b) Spare lubricating oil pump stipulated in *Pt 5, Ch 14, 8.2 Pumps 8.2.1, Pt 5, Ch 14, 8.2 Pumps 8.2.2 and Pt 5, Ch 14, 8.2 Pumps 8.2.3*.
- (c) Spare cooling water pump stipulated in *Pt 5, Ch 14, 7.2 Standby supply 7.2.2*.

■ Section 12 **Control, alarm and safety systems of machinery**

12.1 General

12.1.1 Where machinery is fitted with automatic or remote controls so that under normal operating conditions it does not require any manual intervention by the operators, it is to be provided with the alarms and safety arrangements required by *Pt 5, Ch 14, 12.2 Thermal fluid heaters to Pt 5, Ch 14, 12.4 Miscellaneous machinery*, as appropriate. Alternative arrangements which provide equivalent safeguards will be considered.

12.1.2 Where machinery is arranged to start automatically or from a remote control station, interlocks are to be provided to prevent start-up under conditions which could hazard the machinery.

12.1.3 Where machinery specified in this Section is required to be provided with a standby pump, the standby pump is to start automatically if the discharge pressure from the working pumps falls below a predetermined value.

12.1.4 Where a first stage alarm together with a second stage alarm and automatic shutdown of machinery are required in the relevant Tables of this Section, the sensors and circuits utilised for the second stage alarm and automatic shutdown are to be independent of those required for the first stage alarm.

12.2 Thermal fluid heaters

12.2.1 Alarms and safeguards are indicated in *Pt 5, Ch 14, 12.2 Thermal fluid heaters 12.2.2 to Pt 5, Ch 14, 12.2 Thermal fluid heaters 12.2.8* and *Table 14.12.1 Thermal fluid heaters: Alarms and safeguards*.

Table 14.12.1 Thermal fluid heaters: Alarms and safeguards

Item	Alarm	Note
Expansion tank level*	Low	Fuel oil burners to be shut off automatically
Thermal fluid flow	Low	Fuel oil burners to be shut off automatically, see Note 5
Thermal fluid pressure	Low	Fuel oil burners to be shut off automatically
Thermal fluid outlet temperature*	1st stage high	—
	2nd stage high	Fuel oil burners to be shut off automatically, see <i>Pt 5, Ch 14, 12.1 General 12.1.4</i>
Combustion air pressure*	Low	Fuel oil burners to be shut off automatically in operation or not released during start-up, see Note 3. Purge sequence to be inhibited see <i>Pt 5, Ch 14, 3.1 Oil burning units 3.1.9</i>
Fuel oil pressure*	Low	—
Fuel oil temperature or viscosity*	High and low	Heavy oil only
Fuel oil atomising steam/air pressure	Low	—
Burner flame*	Failure	Each burner to be monitored. Fuel oil to burner to be shut off automatically, see <i>Pt 5, Ch 14, 3.1 Oil burning units 3.1.11 to Pt 5, Ch 14, 3.1 Oil burning units 3.1.12</i> , and Note 3
Flame monitoring device(s)*	Failure	See <i>Pt 5, Ch 14, 12.2 Thermal fluid heaters 12.2.6</i> and Note 3
Igniter power supply*	Failure	Each igniter to be checked before fuel oil is supplied to burner(s), see <i>Pt 5, Ch 14, 12.2 Thermal fluid heaters 12.2.5</i> and Note 3
Forced draft fan*	Power failure	Fuel oil burners to be shut off automatically in operation or not released during start-up, see Note 3
Air register and dampers (including those in the uptake)*	Not fully open	Purge sequence to be inhibited, see <i>Pt 5, Ch 14, 3.1 Oil burning units 3.1.9</i>
Control system*	Power failure	Fuel oil burners to be shut off automatically. Control using alternative arrangement is to remain available, see <i>Pt 6, Ch 1, 2.5 Control systems, general requirements 2.5.7</i>

Uptake temperature	High	To monitor for soot fires. Fuel oil to the burner is to be shut off, see Notes 4 and 6
<p>Note 1. Special consideration may be given to the requirements for oil-fired hot water heaters.</p> <p>Note 2. For heaters not supplying thermal oil for services essential for the safety or the operation of the ship at sea, only the items marked* are required.</p> <p>Note 3. These safeguards are to remain operative during automatic, manual and emergency operation.</p> <p>Note 4. Alarm and fuel oil shut-off is only required where exhaust gas economisers/boilers are fitted.</p> <p>Note 5. For exhaust gas economisers/boilers requiring thermal fluid forced circulation, the low flow alarm is to be fitted with provision to override the alarm if the exhaust gas economiser/boiler is to be operated in the dry condition. See also Pt 5, Ch 14, 6.2 Feed and circulation pumps 6.2.5.</p> <p>Note 6. Alternatively, details of an appropriate fire detection system are to be submitted for consideration.</p>		

12.2.2 The standby pumps for fuel oil and thermal fluid circulation are to start automatically when the discharge pressure from the working pump falls below a predetermined value. The standby pumps for thermal fluid circulation are to start before shut-off due to low thermal fluid pressure, see Table 14.12.1 *Thermal fluid heaters: Alarms and safeguards*, is activated.

12.2.3 The following heater services are to be fitted with automatic controls so as to maintain steady state conditions throughout the operating range of the heater:

- (a) Combustion system.
- (b) Fuel oil supply temperature or viscosity (heavy oil only).
- (c) Thermal fluid temperature.

12.2.4 Burner controls are to be arranged such that light-off is only possible at the minimum firing rate compatible with flame establishment. If ignition is set to occur at a fuel rich condition then the burner is to revert to the correct operating air/fuel ratio on establishment of a stable flame.

12.2.5 Arrangements are to be such that burner fuel oil valve(s) do not open:

- (a) prior to completion of required warm up times for residual fuel oil; or
- (b) when the power supply to the igniter has failed, as applicable; or
- (c) until a pilot flame is established, as applicable; or
- (d) prior to the completion of furnace purging, see Pt 5, Ch 14, 3.1 *Oil burning units* 3.1.7.

12.2.6 Arrangements for flame failure detection are to be provided with self-monitoring capabilities which ensure that the flame detector is not erroneously indicating the presence of a flame. In the event of failure being detected by these self-monitoring capabilities:

- an alarm is to be activated;
- In the event of loss of flame detection capability for a burner;
- fuel oil to the burner is to be shut off automatically; and
- an alarm is to be activated.

12.2.7 Where established as necessary by Pt 5, Ch 14, 3.1 *Oil burning units* 3.1.8, means are to be provided to prevent starting of the ignition sequence following multiple flame failures until completion of the identified lock-out period.

12.2.8 Following burner shutdown, the furnace is to be purged automatically for at least the required pre-purging time. In event of shutdown due to activation of a required safeguard, this purging is to be manually initiated.

12.3 Incinerators

12.3.1 Alarms and safeguards are indicated in Pt 5, Ch 14, 12.3 *Incinerators* 12.3.2, Pt 5, Ch 14, 12.3 *Incinerators* 12.3.3 and Table 14.12.2 *Incinerators: Alarms and safeguards*.

Table 14.12.2 Incinerators: Alarms and safeguards

Item	Alarm	Note
Fuel oil temperature or viscosity	High and low	Heavy oil and sludge
Fuel oil pressure	Low	—
Combustion air pressure	Low	Fuel oil and/or sludge to burners to be shut off automatically
Burner flame and ignition	Failure	Fuel oil and/or sludge to burners to be shut off automatically, see Note
Furnace temperature	High	Fuel oil and/or sludge to burners to be shut off automatically
Furnace temperature	Low	If applicable
Exhaust temperature	High	—

Note Combustion spaces are to be purged automatically before re-ignition takes place in the event of a flame-out on all burners.

12.3.2 Where arrangements are provided to introduce solid waste into the furnace, these are to be such that there is no risk of a fire hazard.

12.3.3 The combustion temperature is to be controlled to ensure that all liquid and solid waste is efficiently burned without exceeding predetermined temperature limits.

12.4 Miscellaneous machinery

12.4.1 Alarms and safeguards are indicated in *Pt 5, Ch 14, 12.4 Miscellaneous machinery 12.4.2 to Pt 5, Ch 14, 12.4 Miscellaneous machinery 12.4.6 and Table 14.12.3 Miscellaneous machinery: Alarms and safeguards.*

Table 14.12.3 Miscellaneous machinery: Alarms and safeguards

Item	Alarm	Note
Sterntube lubricating oil tank level	Low	—
Sterntube bearing temperature (oil lubricated)	High	—
Coolant tanks level	Low	—
Fuel oil service tanks level	High and low	Where a common overflow tank is fitted, a high level alarm in the common overflow tank may be accepted
Fuel oil service tanks temperature	High	Where heating arrangements are fitted
Fuel oil settling tanks temperature	High	Where heating arrangements are fitted
Sludge tanks level	High	—
Feed water tanks level	Low	Service tank only
Purifier water seal broken	Fault	—
Purifier oil inlet temperature	High	—
Air compressor lubricating oil	Failure	Automatic shutdown
Air compressor discharge air temperature	High	—
Hydraulic control system pressure	Low	—
Pneumatic control system pressure	Low	—

Oil heater temperature	High	—
Control environmental conditions	Abnormal	See also Pt 6, Ch 1, 1.3 Control, alarm and safety equipment 1.3.3

12.4.2 **Dual fuel systems.** Oil and gas dual-fired systems for boilers and engines are to be provided with indication to show which fuel is in use.

12.4.3 **Lifts.** For details of alarms and safeguards for lifts classed by LR, reference is to be made to LR's *Code for Lifting Appliances in a Marine Environment, November 2015*.

12.4.4 **Oil heaters.** Fuel oil or lubricating oil heaters are to be fitted with a high temperature alarm which may be incorporated in the temperature control system. In addition to the temperature control system, an independent sensor with manual reset is to be fitted, which will automatically cut off the heating supply in the event of excessively high temperatures or loss of flow, except where the maximum temperature of the heating medium remains limited to a value below 220°C.

12.4.5 **Oil tank electric heating.** Fuel oil and lubricating oil tanks that are provided with electric heating elements are to be fitted with a high temperature alarm, which may be incorporated in the temperature control system, a low level alarm and an additional low level sensor to cut off the power supply at a level above that at which the heating element would be exposed.

12.4.6 **Fuel oil tanks.** Means are to be provided to eliminate the possibility of overflow from fuel oil service tanks into the machinery space and to safeguard against overflow of oil from fuel oil service tanks through the air pipe. See Pt 5, Ch 13 *Ship Piping Systems* regarding the termination of air pipes.

Section

- 1 **General requirements**
- Cross-reference**
- 2 **Piping systems for bilge, ballast, fuel oil, etc.**
- 3 **Cargo handling system**
- 4 **Cargo tank venting, purging and gas-freeing**
- 5 **Cargo tank level gauging equipment**
- 6 **Cargo heating arrangements**
- 7 **Inert gas systems on Tankers of 8,000 tonnes DWT and above**
- Cross-reference**

■ *Section 1*
General requirements

1.1 Application

1.1.1 The requirements of this Chapter are additional to those of *Pt 5, Ch 13 Ship Piping Systems* and are applicable to ships which are intended for the carriage of oil in bulk.

1.1.2 The requirements are based on the assumption that the ships are of normal tanker type having the main propelling machinery aft. Departures from this arrangement will require special consideration.

1.1.3 The requirements are primarily intended for ships which are to carry flammable liquids having a flash point not exceeding 60°C (closed-cup test).

1.1.4 Where ships are intended to carry specific cargoes which are non-flammable or which have a flash point exceeding 60°C, the requirements will be modified, where necessary, to take account of the lesser hazards associated with the cargoes.

1.1.5 For list of cargoes which can be carried in oil tankers, see *Table 9.1.2 Oil cargoes suitable for carriage in oil tankers*, see *Note 1 in Pt 4, Ch 9 Double Hull Oil Tankers*.

1.2 Plans and particulars

1.2.1 In addition to the plans and particulars required in *Pt 5, Ch 13 Ship Piping Systems*, the following plans (in a diagrammatic form) are to be submitted for consideration:

- Pumping arrangement at the fore and aft ends and drainage of cofferdams and pump-rooms.
- General arrangement of cargo piping in tanks and on deck.
- General arrangement of cargo tank vents. The plan is to indicate the type and position of the vent outlets from any superstructure, erection, air intake, etc.
- Arrangement of inert gas piping system together with details of inert gas generating plant including all control and monitoring devices.
- Piping arrangements for cargo oil (F.P. 60°C or above, closed-cup test).
- Ventilation arrangements of cargo and/or ballast pump-rooms and other enclosed spaces which contain cargo handling equipment.
- Arrangements for venting, purging and gas measurement for double hull and double bottom spaces.
- Details of alarms and safety arrangements required by *Pt 5, Ch 15, 1.6 Cargo pump-room*, see also *Pt 6, Ch 1, 2 Essential features for control, alarm and safety systems*.

1.3 Materials

1.3.1 All materials used in the cargo pumping and piping systems are to be suitable for use with the intended cargoes and, where applicable, they are to comply with the requirements of *Pt 5, Ch 12 Piping Design Requirements*.

1.3.2 The requirements of *Pt 5, Ch 15, 1.3 Materials 1.3.1* are also applicable to other piping systems which may come into contact with cargo.

1.4 Design

1.4.1 All piping, valves and fittings are to be suitable for the maximum pressure to which the system can be subjected.

1.4.2 Piping subject to pressure is to be of seamless or other approved type, and is to comply with the requirements of *Pt 5, Ch 12 Piping Design Requirements*.

1.5 Hazardous zones and spaces

1.5.1 Oil engines, or any other equipment which could constitute a possible source of ignition, are not to be situated within cargo tanks, pump-rooms, cofferdams or other spaces liable to contain petroleum or other explosive vapours, or in spaces or zones immediately adjacent to cargo oil or slop tanks. The temperature of steam, or other fluid, in pipes (or heating coils) in these spaces is not to exceed 220°C. On gas tankers and chemical tankers, the maximum temperature is not to exceed that of the required temperature class of electrical equipment in the cargo area.

1.5.2 For definition of hazardous zones and spaces and requirements for electrical equipment within such spaces, see *Pt 6, Ch 2, 14.5 Hazardous zones and spaces*.

1.5.3 For the requirements for earthing and bonding of pipework for the control of static electricity, see *Pt 6, Ch 2, 1.13 Bonding for the control of static electricity*.

1.6 Cargo pump-room

1.6.1 Control engineering systems are to be in accordance with the requirements of *Pt 6, Ch 1 Control Engineering Systems*.

1.6.2 Cargo pump-rooms are to be totally enclosed and are to have no direct communication with machinery spaces. For bilge drainage arrangements in pump-room, see *Pt 5, Ch 15, 2.2 Cargo pump-room drainage*.

1.6.3 Pump-rooms are to be situated within, or adjacent to the cargo tank area and are to be provided with ready means of access from the open deck, see also *Pt 4, Ch 9, 13 Access arrangements and closing appliances*.

1.6.4 In cargo pump-rooms any drain pipes from steam or exhaust pipes from the steam cylinders of the pumps are to terminate well above the level of the bilges.

1.6.5 Alarms and safety arrangements are to be provided as indicated in *Pt 5, Ch 15, 1.6 Cargo pump-room 1.6.6* and *Table 15.1.1 Alarms and safety arrangements*. These requirements are applicable to pump-rooms where pumps for cargo, such as cargo pumps, stripping pumps, pumps for slop tanks, pumps for COW or similar pumps are provided and not for pump-rooms intended solely for ballast transfer. See also *Pt 5, Ch 15, 1.6 Cargo pump-room 1.6.7*.

Table 15.1.1 Alarms and safety arrangements

Item	Alarm	Note
Temperature sensing of bulkhead shaft glands, bearings and pump casings	High see Note 1	Cargo, ballast and stripping pumps
Bilge level	High	—
Hydrocarbon concentration	High see Note 2	> 10% LEL
<p>Note 1. The alarm signals shall trigger continuous visual and audible alarms in the cargo control room or the pump control station.</p> <p>Note 2. This alarm signal shall trigger a continuous audible and visual alarm in the pump-room, cargo control room, engine control room and bridge.</p>		

1.6.6 A system for continuously monitoring the concentrations of hydrocarbon gases within the cargo pump-room is to be fitted. Monitoring points are to be located in positions where potentially dangerous concentrations may be readily detected. Gas

analysing units with non-safe-type measuring equipment may be located outside cargo areas (e.g. in cargo control room, navigation bridge or engine room when mounted on the forward bulkhead) provided that:

- (a) sampling lines do not pass through gas safe spaces, except where permitted by *Pt 5, Ch 15, 1.6 Cargo pump-room 1.6.6*;
- (b) the gas sampling pipes are fitted with flame arresters. Sample gas is to be led to the atmosphere with outlets arranged in a safe location, in the open atmosphere;
- (c) bulkhead penetrations of sample pipes between safe and dangerous areas are of an approved type. A manual isolating valve is to be fitted in each of the sampling lines at the bulkhead in the safe area;
- (d) the gas detection equipment including sampling piping, sampling pumps, solenoid valves and analysing units, are located in a fully enclosed steel cabinet, with a gasketed door, monitored by its own sampling point. At gas concentrations above 30 per cent LEL inside the steel cabinet, the entire gas-analysing unit is to be automatically shutdown; and
- (e) where the cabinet cannot be arranged on the bulkhead, sample pipes are to be of steel or other equivalent material and without detachable connections, except for the connection points for isolating valves at the bulkhead and analysing units. The sample pipes are to be led by their shortest route.

Sequential sampling is acceptable as long as it is dedicated for the pump-room only, including exhaust ducts, and the detection equipment is capable of monitoring from each sampling head location at intervals not exceeding 30 minutes.

1.6.7 Where items of equipment other than described in *Table 15.1.1 Alarms and safety arrangements* are located in the pump-room and are driven by shafts passing through bulkheads, the potential risk of ignition of hydrocarbon gas is to be assessed and proposals for mitigation submitted to LR for consideration.

1.7 Arrangements for fixed hydrocarbon gas detection systems in double hull and double bottom spaces of oil tankers

1.7.1 In accordance with SOLAS 1974, as amended, Ch II-2/B, Reg. 4. 5.7 *Gas measurement and detection*, double hull and double bottom spaces of oil tankers with a deadweight of 20 000 tonnes and above that are not provided with a constant operative inerting system (COIS) are to be provided with a fixed hydrocarbon gas detection system.

1.7.2 Where a fixed hydrocarbon gas detection system is required by *Pt 5, Ch 15, 1.7 Arrangements for fixed hydrocarbon gas detection systems in double hull and double bottom spaces of oil tankers 1.7.1*, it is to be of an approved type and it is to meet the requirements of *Chapter 16 - Fixed Hydrocarbon Gas Detection Systems of the FSS Code - Fire Safety Systems - Resolution MSC.98(73)*.

1.7.3 Where a constant operative inerting systems (COIS) is provided in lieu of fixed hydrocarbon detection the arrangements are to be submitted for consideration.

1.8 Cargo pump-room ventilation

1.8.1 Cargo pump-rooms and other closed spaces which contain cargo handling equipment, and to which regular access is required during cargo handling operations, are to be provided with permanent ventilation systems of the mechanical extraction type.

1.8.2 The ventilation system is to be capable of being operated from outside the compartment being ventilated and a notice to be fixed near the entrance stating that no person is to enter the space until the ventilation system has been in operation for at least 15 minutes.

1.8.3 The ventilation systems are to be capable of 20 air changes per hour, based on the gross volume of the pump-room or space.

1.8.4 The ventilation ducting is to be arranged to permit extraction from the vicinity of the pump-room bilges, immediately above the transverse floor plates or bottom longitudinals. An emergency intake is also to be arranged in the ducting at a height of 2 m above the pump-room lower platform and is to be provided with a damper capable of being opened or closed from the weather deck and lower platform level. An arrangement involving a specific ratio of areas of upper emergency and lower main ventilation openings, which can be shown to result in at least the required number of air changes through the lower inlets, can be accepted without the use of dampers. When the lower inlets are sealed off, owing to flooding of the bilges, then at least 75 per cent of the required number of air changes is to be obtainable through the upper inlets. Means are to be provided to ensure the free flow of gases through the lower platform to the duct intakes.

1.8.5 Protection screens of not more than 13 mm square mesh are to be fitted in outside openings of ventilation ducts, and ventilation intakes are to be so arranged as to minimise the possibility of recycling hazardous vapours from any ventilation discharge opening. Vent exits are to be arranged to discharge to a safe place on the open deck and comply with the requirements of *Pt 5, Ch 15, 1.8 Cargo pump-room ventilation 1.8.6*.

1.8.6 The vent exits from pump-rooms are to discharge at least 3 m above deck, and from the nearest air intakes or openings to accommodation and enclosed working spaces, and from possible sources of ignition.

1.8.7 The ventilation is to be interlocked to the lighting system (except emergency lighting) such that the cargo pump-room lighting may only come on when the ventilation is in operation. Failure of the ventilation system shall not cause the lighting to go out.

1.9 Non-sparking fans for hazardous areas

1.9.1 The air gap between impeller and housing of the fan is to be not less than 0,1 of the impeller shaft bearing diameter or 2 mm whichever is the larger, subject also to compliance with *Pt 5, Ch 15, 1.9 Non-sparking fans for hazardous areas 1.9.2*. Generally, however, the air gap need be no more than 13 mm.

1.9.2 The following combinations of materials are permissible for the impeller and the housing in way of the impeller:

- (a) impellers and/or housings of non-metallic material, due regard being paid to the elimination of static electricity,
- (b) impellers and housings of non-ferrous metals,
- (c) impellers and housings of austenitic stainless steel,
- (d) impellers of aluminium alloys or magnesium alloys and a ferrous housing provided that a ring of suitable thickness of non-ferrous material is fitted in way of the impeller,
- (e) any combination of ferrous impellers and housings with not less than 13 mm tip clearance,
- (f) any combination of materials for the impeller and housing which are demonstrated as being spark-proof by appropriate rubbing tests.

1.9.3 The following combinations of materials for impellers and housing are not considered spark-proof and are not permitted:

- (a) impellers of an aluminium alloy or magnesium alloy and a ferrous housing, irrespective of tip clearance,
- (b) impellers of a ferrous material and housings made of an aluminium alloy, irrespective of tip clearance,
- (c) any combination of ferrous impeller and housing with less than 13 mm tip clearance, other than permitted by *Pt 5, Ch 15, 1.9 Non-sparking fans for hazardous areas 1.9.2*.

1.9.4 Electrostatic charges both in the rotating body and the casing are to be prevented by the use of antistatic materials (i.e. materials having an electrical resistance between 5×10^4 ohms and 10^8 ohms), or special means are to be provided to avoid dangerous electrical charges on the surface of the material.

1.9.5 Type tests on the complete fan are to be carried out to the Surveyor's satisfaction.

1.9.6 Protection screens of not more than 13 mm square mesh are to be fitted in the inlet and outlet of ventilation ducts to prevent the entry of objects into the fan housing.

1.9.7 The installation of the ventilation units on board is to be such as to ensure the safe bonding to the hull of the units themselves.

1.10 Slop tanks

1.10.1 The requirements in *Pt 5, Ch 15, 1.10 Slop tanks 1.10.2 to Pt 5, Ch 15, 1.10 Slop tanks 1.10.7* are applicable to ships intended for the carriage of ore or oil when oil residues are to be retained in the slop tanks and the ship is otherwise gas free, see also *Pt 4, Ch 9, 11.3 Structural configuration and ship arrangement*.

1.10.2 Slop tanks are to be provided with an approved independent venting system, see *Pt 5, Ch 15, 4 Cargo tank venting, purging and gas-freeing*.

1.10.3 At least two portable instruments are to be available on board for gas detection.

1.10.4 Means are to be provided for isolating the piping connecting the pump-room with the slop tanks. The means of isolation is to consist of a valve followed by a spectacle flange or a spool piece with appropriate blank flanges. This arrangement is to be located adjacent to the slop tanks, but where this is unreasonable or impracticable it may be located within the pump-room directly after the piping penetrates the bulkhead. A separate permanently installed pumping and piping arrangement is to be provided for discharging the contents of the slop tanks directly to the open deck for transfer to shore reception facilities when the ship is in the dry cargo mode. When this transfer system is used for slop transfer in dry cargo mode, it shall have no connection to other systems. Separation by means of removal of spool pieces may be accepted.

1.10.5 Adequate ventilation is to be provided for spaces surrounding slop tanks, see also *Pt 4, Ch 9, 11.3 Structural configuration and ship arrangement*.

1.10.6 Warning notices are to be erected at suitable points detailing precautions to be observed prior to the ship loading or unloading, or when the ship is carrying dry cargo with liquid in the slop tanks.

1.10.7 In order to satisfy the requirements of certain National and/or Terminal Authorities, it may be necessary to provide an inert gas system for blanketing the slop tank contents.

1.11 Steam connections to cargo tanks

1.11.1 Where steaming out and/or fire-extinguishing connections are provided for cargo tanks or cargo pipe lines, they are to be fitted with valves of the screw-down non-return type. The main supply to these connections is to be fitted with a master valve placed in a readily accessible position clear of the cargo tanks.



Cross-reference

See Pt 6, Ch 1, 3 *Ergonomics of control stations* for alarm system requirements.



Section 2

Piping systems for bilge, ballast, fuel oil, etc.

2.1 Pumping arrangements at ends of ship outside hazardous zones and spaces

2.1.1 The pumping arrangements in the machinery space and at the forward end of the ship are to comply with the requirements for general cargo ships, in so far as they are applicable, and with the special requirements detailed in this Section.

2.1.2 Bilge, ballast and fuel oil lines, etc. which are connected to pumps, tanks or compartments at the ends of the ship outside hazardous zones and spaces, are not to pass through cargo tanks or have any connections to cargo tanks or cargo piping. No objection will be made to these lines being led through ballast tanks or void spaces within the range of the cargo tanks.

2.1.3 The fuel oil bunkering system is to be entirely separate from the cargo handling system.

2.1.4 Where non-permanent connections are required in piping systems between non-hazardous and hazardous spaces, two means of isolation are to be provided. One of these means is to provide positive separation by means of a removable spool piece or flexible hose, and blank flanges are to be fitted. The other is to be a non-return valve, or similar, in accordance with an acceptable National or International Standard that is appropriate for the design conditions of the piping system. The non-return valve and removable piece are to be located within the existing hazardous spaces. A notice is also to be provided located in a prominent position adjacent to the means of isolation, clearly indicating that the spool piece or flexible hose is to be removed, and blanking flanges are to be fitted, when the piping is not in use. The removable spool piece is to be clearly identified (labelled/painted in a distinctive colour) and stowed close to its working position.

2.2 Cargo pump-room drainage

2.2.1 Provision is to be made for the bilge drainage of the cargo pump-rooms by pump or bilge ejector suction. The cargo pumps or cargo stripping pumps may be used for this purpose, provided that the bilge suction is fitted with screw-down non-return valves and, in addition, an isolating valve or cock is fitted on the pump connection to the bilge chest. The pump-room bilges of small tankers may be drained by means of a hand pump having a 50 mm bore suction. Pump-room suction is not to enter machinery spaces.

2.3 Deep cofferdam drainage

2.3.1 Cofferdams, which are required to be provided at the fore and aft ends of the cargo spaces in accordance with Pt 4, Ch 9, 1.2 *Application and ship arrangement* are to be provided with suitable drainage arrangements. Examples of acceptable arrangements are detailed in Pt 5, Ch 15, 2.3 *Deep cofferdam drainage* 2.3.2 and Pt 5, Ch 15, 2.3 *Deep cofferdam drainage* 2.3.3.

2.3.2 Where deep cofferdams can be filled with water ballast, a ballast pump in the main engine room may be used for emptying the after cofferdam. Where fitted, a ballast pump in a forward pump-room may be used for emptying the forward cofferdam. In each case, the suctions are to be led direct to the pump and not to a pipe system.

2.3.3 Where intended to be dry compartments, after cofferdams adjacent to the pump-room may be drained by a cargo pump, provided that isolating arrangements are fitted in the bilge system as required by *Pt 5, Ch 15, 2.2 Cargo pump-room drainage 2.2.1*; forward cofferdams may be drained by a bilge and ballast pump in a forward pump-room. Alternatively, cofferdams may be drained by bilge ejectors or, in the case of small ships, by hand pumps.

2.3.4 Cofferdams are not to have any direct connections to the cargo tanks or cargo lines.

2.4 Drainage of ballast tanks and void spaces within the range of the cargo tanks

2.4.1 Ballast tanks and void spaces within the range of the cargo tanks are not to be connected to cargo pumps, or have any connections to the cargo system. A separate ballast/bilge pump is to be provided for dealing with the contents of these spaces. This pump is to be located in the cargo pump-room or other suitable space within the range of the cargo tanks.

2.4.2 Ballast pumps shall be provided with suitable arrangements to ensure efficient suction from ballast tanks.

2.4.3 Where submerged water ballast pumps are fitted, they are to be located in separate compartments on opposite sides of the ship such that, in the event of hull damage due to grounding or collision, the risk of total loss of ballast pumping capability is minimised.

2.4.4 Ballast piping is not to pass through cargo tanks and is not to be connected to cargo oil piping. Provision may, however, be made for emergency discharge of water ballast by means of a portable spool connection to a cargo oil pump and where this is arranged, a non-return valve is to be fitted in the ballast suction to the cargo oil pump.

2.4.5 Consideration will be given to connecting double bottom and/or wing tanks, which are in the range of the cargo tanks, to pumps in the machinery space where the tanks are completely separated from the cargo tanks by cofferdams, heating ducts or containment spaces, etc.

2.5 Air and sounding pipes

2.5.1 Deep cofferdams at the fore and aft ends of the cargo spaces and other tanks or cofferdams within the range of the cargo tanks, which are not intended for cargo, are to be provided with air and sounding pipes led to the open deck. The air pipes are to be fitted with gauze diaphragms at their outlets.

2.5.2 The air and sounding pipes required by *Pt 5, Ch 15, 2.5 Air and sounding pipes 2.5.1* are not to pass through cargo tanks.

2.5.3 On oil tankers of less than 5000 tonnes deadweight, where wing ballast tanks or spaces are not required, the sounding and air pipes to double bottom spaces below cargo tanks may pass through the cargo tanks. However, the pipes are to be of heavy gauge steel, and they are to be in continuous lengths or with welded joints.

2.6 Ballast piping in pump-room double bottoms

2.6.1 Ballast piping is permitted to be located within the cargo pump-room double bottom provided any damage to that piping does not render the ship's ballast and cargo pumps, located in the cargo pump-room, ineffective.

2.7 Fore peak ballast tank

2.7.1 The fore peak tank can be ballasted with the system serving other ballast tanks within the cargo area, provided that:

- (a) the fore peak tank is considered as a hazardous area;
- (b) the vent pipe openings are located on open deck at an appropriate distance from sources of ignition. In this respect, the hazardous zones distances are to be defined in accordance with *Pt 6, Ch 2, 14.5 Hazardous zones and spaces*;
- (c) means are provided, on the open deck, to allow measurement of flammable gas concentrations within the fore peak tank by a suitable portable instrument;
- (d) the sounding arrangement to the fore peak tank is direct from open deck; and
- (e) the access to the fore peak tank is direct from open deck; alternatively, indirect access from the open deck to the fore peak tank through an enclosed space may be accepted, provided that:
 - (i) in case the enclosed space is separated from the cargo tanks by cofferdams, the access is through a gas-tight bolted manhole located in the enclosed space and a warning sign is to be provided at the manhole, stating that the fore peak

tank may only be opened after it has been proven to be gas free, or any electrical equipment which is not certified safe in the enclosed space is isolated.

- (ii) where the enclosed space has a common boundary with the cargo tanks and is therefore a hazardous area, the enclosed space is to be well ventilated.

■ Section 3 Cargo handling system

3.1 General

3.1.1 A complete system of piping and pumps is to be fitted for dealing with the cargo.

3.1.2 Standby means for pumping out each cargo tank are to be provided.

3.1.3 Where cargo tanks are provided with single deep well pumps, or submerged pumps, it will be necessary to provide alternative means for emptying the tanks in the event of the failure of a pump. Portable submersible pumps may be provided on board for this purpose, but the arrangements are to be such that a portable pump could be safely introduced into a full or part-full tank. Details of the arrangements are to be submitted.

3.1.4 Provision is to be made for the gas freeing of the cargo oil tanks when the cargo has been discharged, and for the ventilation and gas freeing of all compartments adjacent to cargo oil tanks. It is recommended that arrangements be provided to enable double bottom tanks situated below cargo tanks to be filled with water ballast to assist in the gas freeing of these tanks, see also *Pt 5, Ch 15, 7.3 Venting arrangements 7.3.2*.

3.1.5 At least two portable instruments are to be available on board for gas detection.

3.1.6 Cargo tank access hatches and all other openings to cargo tanks, such as ullage and tank cleaning openings and restricted sounding devices, see *Pt 5, Ch 15, 5.2 Restricted sounding device*, are to be located on the weather deck.

3.2 Cargo pumps

3.2.1 Pumps for the purpose of filling or emptying the cargo oil tanks are to be used exclusively for this purpose, except as provided in *Pt 5, Ch 15, 2.2 Cargo pump-room drainage 2.2.1*. They are not to have any connections to compartments outside the range of cargo oil tanks.

3.2.2 Means are to be provided for stopping the cargo oil pumps from a position outside the pump-rooms, as well as at the pumps.

3.2.3 The pumps are to be provided with effective relief valves which are to be in closed circuit, i.e. discharging to the suction side of the pumps. Alternative proposals to safeguard against over-pressure on the discharge side of the pump will be specially considered.

3.2.4 Where cargo pumps are driven by shafting which passes through a pump-room bulkhead or deck, gastight glands are to be fitted to the shaft at the pump-room plating. The glands are to be efficiently lubricated from outside the pump-room. The seal parts of the glands are to be of materials that will not initiate sparks. The glands are to be of an approved type and are to be attached to the bulkhead in accordance with *Pt 5, Ch 13, 2.4 Attachment of valves to watertight plating*. Where a bellows piece is incorporated in the design, it is to be hydraulically tested to 3,4 bar (3,5 kgf/cm²) before fitting.

3.2.5 Where cargo pumps are driven by hydraulic motors which are located inside cargo tanks, the design is to be such that contamination of the operating medium with cargo liquid cannot take place under normal operating conditions. The arrangements are to comply with *Pt 5, Ch 15, 3.7 Remote control valves 3.7.7* and *Pt 5, Ch 15, 3.7 Remote control valves 3.7.8*, in so far as they are applicable.

3.3 Cargo piping system

3.3.1 Cargo piping and similar piping to cargo tanks are not to pass through ballast tanks.

3.3.2 Cargo pipes are not to pass through tanks or compartments which are outside the cargo tank area.

3.3.3 Means are to be provided to enable the contents of the cargo lines pumps to be drained to a cargo tank or other suitable tank. Where drain tanks are fitted in pump-rooms, they are to be of the closed type with air and sounding pipes led to the open deck.

3.3.4 Expansion joints of approved type or bends are to be provided, where necessary, in the cargo pipe lines.

3.3.5 Expansion pieces of an approved type, incorporating oil resistant rubber or other suitable material, may be accepted in cargo piping, *see also Pt 5, Ch 13, 2.7 Provision for expansion 2.7.2.*

3.3.6 In combination carriers where cargo wing tanks are provided, cargo oil lines below deck are to be installed inside these tanks. However, Lloyd's Register (hereinafter referred to as 'LR') may permit cargo oil lines to be placed in special ducts which are to be capable of being adequately cleaned and ventilated to the satisfaction of LR's Surveyors. Where cargo wing tanks are not provided cargo oil lines below deck are to be placed in special ducts.

3.3.7 Means are to be provided for keeping deck spills away from accommodation and service areas. This may be accomplished by means of a 300 mm coaming extending from side to side. Special consideration shall be given to the arrangements associated with stern loading.

3.4 Terminal fittings at cargo loading stations

3.4.1 Terminal pipes, valves and other fittings in the cargo loading and discharging lines to which shore installation hoses are directly connected, are to be of steel or approved ductile material. They are to be of robust construction and strongly supported, *see also Pt 5, Ch 15, 1.3 Materials and Pt 5, Ch 15, 1.4 Design.*

3.4.2 A manually operated shut-off valve is to be fitted to each shore loading/discharging connection.

3.4.3 Drip pans for collecting cargo residues in cargo lines and hoses are to be provided beneath pipe and hose connections in the manifold area.

3.5 Bow or stern loading and discharge arrangements

3.5.1 Where a ship is arranged for bow and/or stern loading and discharge of cargo outside the cargo tank area, the pipe lines and related piping and equipment forward and/or aft of the cargo area are to have only welded joints and are to be provided with spectacle flanges or removable spool pieces, where branched off from the main line, and a blank flange at the bow and/or stern end connections, irrespective of the number and type of valves in the line.

3.5.2 The spaces within 4,5 m of flanged connections to, or valves or drip trays associated with, discharge manifolds are to be considered as hazardous spaces with regard to electrical or incandive equipment, *see also Pt 6, Ch 2, 14.10 Requirements for tankers intended for the carriage in bulk of oil cargoes having a flash point not exceeding 60°C (closed-cup test).*

3.6 Connections to cargo tanks

3.6.1 Where cargo tanks are provided with direct filling connections, the loading pipes are to be led to as low a level as practicable inside the tank.

3.6.2 Where cargo suction and/or filling lines are led through cargo tanks, or through other spaces situated below the weather deck, the connection to each tank is to be provided with a valve situated inside the tank, and capable of being operated from the deck. In the case of cargo tanks which are located adjacent to below-deck pump-rooms, or pipe tunnels, the deck operated valves may be located in these spaces at the bulkhead. In any case, not less than two isolating shut-off valves are to be provided in the pipe lines between the tanks and the cargo pumps.

3.7 Remote control valves

3.7.1 Valves on deck and in pump-rooms which are provided with remote control, are, in general, to be arranged for local manual operation independent of the remote operating mechanism, *see also Pt 5, Ch 13, 2.3 Valves – Installation and control 2.3.2 and Pt 5, Ch 13, 2.3 Valves – Installation and control 2.3.3.*

3.7.2 Where the valves and their actuators are located inside the cargo tanks, two separate suction lines are to be provided in each tank, or alternative means of emptying the tank, in the event of a defective actuator, are to be provided.

3.7.3 All actuators are to be of a type which will prevent the valves from opening inadvertently in the event of the loss of pressure in the operating medium. Indication is to be provided at the remote control station showing whether the valve is open or shut.

3.7.4 Materials of construction of the actuators and piping inside the cargo tanks are to be suitable for use with the intended cargo.

3.7.5 Compressed air is not to be used for operating actuators inside cargo tanks.

3.7.6 The actuator operating medium in hydraulic systems is to have a flash point of 60°C or above (closed-cup test) and is to be compatible with the intended cargoes.

3.7.7 The design of the actuators is to be such that contamination of the operating medium with cargo liquid cannot take place under normal operating conditions.

3.7.8 Where the operating medium is oil, or other fluid, the supply tank is to be located as high as practicable above the level of the top of the cargo tanks, and all actuator supply lines are to enter the cargo tanks through the highest part of the tanks. Furthermore, the supply tank is to be of the closed type with an air pipe led to a safe space on the open deck and fitted with a flameproof wire gauze diaphragm at its open end. This tank is also to be fitted with a high and low level audible and visual alarm. The requirements of this paragraph need not be complied with if the actuators and piping are located external to the cargo tanks.

3.7.9 It is recommended that for remote control valves not arranged for manual operation, emergency means be provided for operating the valve actuators in the event of damage to the main hydraulic circuits on deck. In the case of valves located inside cargo tanks, this could be achieved by ensuring that the supply lines to the actuators are led vertically inside the tanks from deck, and that connections, with necessary isolating valves, are provided on deck for coupling to a portable pump carried on board.

3.8 Cargo handling controls

3.8.1 Electrical measuring, monitoring control and communication circuits located in hazardous spaces are to be in accordance with *Pt 6, Ch 2, 14.2 Selection of equipment for use in explosive gas atmospheres*, appropriate to the defined hazardous zone.

3.8.2 The handling controls and instruments are to be arranged for safe and easy operation. They may be grouped at a number of control stations or at one main control station.

3.8.3 A satisfactory means of communication is to be provided between cargo handling stations, open deck, the bridge and the machinery space.

3.8.4 The cargo handling controls and instrumentation are, so far as possible, to be separate from the propulsion and auxiliary machinery controls and instrumentation.

■ *Section 4*

Cargo tank venting, purging and gas-freeing

4.1 Cargo tank venting

4.1.1 The venting systems of cargo tanks are to be entirely distinct from the air pipes of the other compartments of the ship. The arrangements and position of openings in the cargo tank deck from which emission of flammable vapours can occur are to be such as to minimise the possibility of flammable vapours being admitted to enclosed spaces containing a source of ignition, or collecting in the vicinity of deck machinery and equipment which may constitute an ignition hazard.

4.1.2 The venting arrangements are to be so designed and operated as to ensure that neither pressure nor vacuum in cargo tanks exceeds design parameters and are to be such as to provide for:

- (a) the flow of the small volumes of vapour, air or inert gas mixtures caused by thermal variations in a cargo tank in all cases through pressure/vacuum valves: and
- (b) the passage of large volumes of vapour, air or inert gas mixtures during cargo loading and ballasting, or during discharging.
- (c) a secondary means of allowing full flow relief of vapour, air or inert gas mixtures to prevent overpressure or underpressure in the event of failure of the arrangements in *Pt 5, Ch 15, 4.1 Cargo tank venting 4.1.2*. Alternatively, pressure sensors may be fitted to monitor the pressure in each tank protected by the arrangement required in *Pt 5, Ch 15, 4.1 Cargo tank venting 4.1.2*, with a monitoring system in the ship's cargo control room or the position from which cargo operations are normally carried out. Such monitoring equipment is also to provide an alarm facility which is activated by detection of over-pressure or under-pressure conditions within a tank.

4.1.3 The venting arrangements in each cargo tank may be independent or combined with other cargo tanks and may be incorporated into the inert gas piping.

4.1.4 Where the arrangements are combined with other cargo tanks either stop valves or other acceptable means are to be provided to isolate each cargo tank. Where stop valves are fitted, they are to be provided with locking arrangements which are to be under the control of the responsible ship's officer.

4.1.5 There is to be a clear visual indication of the operational status of the valves, or other acceptable means. Where tanks have been isolated, it is to be ensured that the relevant isolating valves are opened before cargo loading or ballasting or discharging of those tanks is commenced. Any isolation is to continue to permit the flow caused by thermal variations in a cargo tank in accordance with *Pt 5, Ch 15, 4.1 Cargo tank venting 4.1.2*.

4.1.6 If cargo loading and ballasting or discharging of a cargo tank or cargo tank group, which is isolated from a common venting system is intended, that cargo tank or cargo tank group is to be fitted with a means for over-pressure or under-pressure protection as required in *Pt 5, Ch 15, 4.1 Cargo tank venting 4.1.2*.

4.1.7 The venting arrangements are to be connected to the top of each cargo tank and are to be self-draining to the cargo tanks under all normal conditions of trim and list of the ship. Where it may not be possible to provide self-draining lines permanent arrangements are to be provided to drain the vent lines to a cargo tank.

4.1.8 The venting system is to be provided with devices to prevent the passage of flame into the cargo tanks. The design, testing and locating of these devices are to comply with recognised International Standards.

4.1.9 Ullage openings are not to be used for pressure equalisation and they should be fitted with self-closing tightly sealing covers. Flame arrestors and screens are not permitted in these openings.

4.1.10 Provision is to be made to guard against liquid rising in the venting system to a height which would exceed the design head of cargo tanks. This is to be accomplished by overflow control systems, or other equivalent means, e.g. overfill alarms, together with gauging devices and cargo tank filling procedures but not spill valves which are not considered equivalent to an overflow system. The system for guarding against liquid rising to a height which would exceed the design head of cargo tanks is to be independent of the gauging devices.

4.1.11 Openings for pressure release required by *Pt 5, Ch 15, 4.1 Cargo tank venting 4.1.2* are to:

- (a) have as great a height as is practicable above the cargo tank deck to obtain maximum dispersal of flammable vapours but in no case less than 2 m above the cargo tank deck, and
- (b) be arranged at the furthest distance practicable but not less than 5 m from the nearest air intakes and openings to enclosed spaces containing a source of ignition and from deck machinery, chain locker openings and equipment which may constitute an ignition hazard.

4.1.12 Pressure/vacuum valves required by *Pt 5, Ch 15, 4.1 Cargo tank venting 4.1.2* may be provided with a by-pass arrangement when they are located in a vent main or masthead riser. Where such an arrangement is provided there are to be suitable indicators to show whether the by-pass is open or closed.

4.1.13 Vent outlets for cargo loading, discharging and ballasting required by *Pt 5, Ch 15, 4.1 Cargo tank venting 4.1.2* are to:

- (a) permit the free flow of vapour mixtures or alternatively, permit the throttling of the discharge of the vapour mixtures to achieve a velocity of not less than 30 m/sec;
- (b) be so arranged that the vapour mixture is discharged vertically upwards;
- (c) where the method is by free flow of vapour mixtures, be such that the outlet is not less than 6 m above the cargo tank deck or fore and aft gangway if situated within 4 m of the gangway and located not less than 10 m measured horizontally from the nearest air intakes and openings to enclosed spaces containing a source of ignition and from deck machinery, chain locker openings and equipment which may constitute an ignition hazard;
- (d) where the method is by high velocity discharge, be located at a height not less than 2 m above the cargo tank deck and not less than 10 m measured horizontally from the nearest air intakes and openings to enclosed spaces containing a source of ignition and from deck machinery, chain locker openings and equipment which may constitute an ignition hazard. These outlets are to be provided with high velocity devices of an approved type; and
- (e) be designed on the basis of the maximum designed loading rate multiplied by a factor of at least 1,25 to take account of gas evolution, in order to prevent the pressure in any cargo tank from exceeding the design pressure. The master is to be provided with information regarding the maximum permissible loading rate for each cargo tank and in the case of combined venting systems, for each group of cargo tanks.

4.1.14 Pressure/vacuum valves are to be set at a positive pressure of not more than 0,2 bar (0,2 kgf/cm²) above atmospheric and a negative pressure of not more than 0,07 bar (0,07 kgf/cm²) below atmospheric. Higher positive pressures not exceeding 0,7 bar (0,7 kgf/cm²) gauge may be permitted in specially designed integral tanks.

4.1.15 In combination carriers the arrangements to isolate slop tanks containing oil or residues from other cargo tanks are to consist of blank flanges which will remain in position at all times when cargoes other than liquid cargoes referred to in 7.5.16 are carried.

4.2 Cargo tank purging and/or gas-freeing

4.2.1 Arrangements for purging and/or gas-freeing are to be such as to minimise the hazards due to the dispersal of flammable vapours in the atmosphere and to flammable mixtures in cargo tank, thus the requirements of *Pt 5, Ch 15, 4.2 Cargo tank purging and/or gas-freeing 4.2.2 to Pt 5, Ch 15, 4.2 Cargo tank purging and/or gas-freeing 4.2.4* are to be complied with, as applicable.

4.2.2 When the ship is provided with an inert gas system the cargo tanks are first to be purged in accordance with the provisions of *Pt 5, Ch 15, 7.3 Venting arrangements 7.3.2* until the concentration of hydrocarbon vapours in the cargo tanks has been reduced to less than two per cent by volume. Thereafter gas freeing may take place at the cargo tank deck level.

4.2.3 When the ship is not provided with an inert gas system, the operation is to be such that the flammable vapour is initially discharged either:

- (a) through the vent outlets as specified in *Pt 5, Ch 15, 4.1 Cargo tank venting 4.1.13*, or
- (b) through outlets at least 2 m above the cargo tank deck level with a vertical efflux velocity of at least 30 m/sec. maintained during gas freeing operation, or
- (c) through outlets at least 2 m above the cargo tank deck level with a vertical efflux velocity of at least 20 m/sec. and which are protected by suitable devices to prevent the passage of flame.

4.2.4 When the flammable vapour concentration at the outlet has been reduced to 30 per cent of the lower flammable limit, gas-freeing may thereafter be continued at the cargo tank deck level.

4.3 Venting, purging and gas measurement of double hull and double bottom spaces

4.3.1 Double hull and double bottom spaces are to be fitted with suitable connections for the supply of air.

4.3.2 On tankers required to be fitted with inert gas systems:

- (a) double hull spaces are to be fitted with suitable connections for the supply of inert gas;
- (b) where such spaces are connected to a permanently fitted inert gas distribution system, means are to be provided to prevent hydrocarbon gases from the cargo tanks entering the double hull spaces through the system;
- (c) where such spaces are not permanently connected to an inert gas distribution system, appropriate means are to be provided to allow connection to the inert gas main.

4.3.3 When selecting portable instruments for measuring oxygen and flammable vapour, due attention is to be given to their use in combination with the fixed gas sampling line systems referred to in *Pt 5, Ch 15, 4.3 Venting, purging and gas measurement of double hull and double bottom spaces 4.3.4*.

4.3.4 Where the atmosphere in double hull spaces cannot be reliably measured using flexible gas sampling hoses, such spaces are to be fitted with permanent gas sampling lines. The configuration of such line systems is to be adopted to the design of such spaces.

4.3.5 The materials of construction and the dimensions of gas sampling lines are to be such as to prevent restriction. Where plastics materials are used, they are to be electrically conductive.

4.4 Gas measurement

4.4.1 All tankers are to be equipped with at least two portable instruments for measuring per cent LEL of hydrocarbon concentrations in air.

4.4.2 All tankers are to be equipped with at least two portable oxygen analysers.

4.4.3 For tankers fitted with an inert gas system two portable gas detectors capable of measuring flammable vapour concentrations in inerted atmospheres are to be provided, see *Pt 5, Ch 15, 7.5 Instrumentation and alarms*.

4.4.4 Suitable means are to be provided for the calibration of gas measurement instruments.

■ **Section 5**
Cargo tank level gauging equipment

5.1 General

5.1.1 Each cargo tank is to be fitted with suitable means for ascertaining the liquid level in the tank in accordance with the requirements of *Pt 5, Ch 15, 5.2 Restricted sounding device* and *Pt 5, Ch 15, 5.3 Closed sounding devices*.

5.2 Restricted sounding device

5.2.1 Sounding pipes or other approved devices, which may permit a limited amount of vapour to escape to atmosphere when being used, would be accepted for those tanks which are not required to be fitted with closed sounding devices, *see Pt 5, Ch 15, 5.3 Closed sounding devices*. The devices are to be so designed as to minimise the sudden release of vapour or liquid under pressure and the possibility of liquid spillage on deck. Means are also to be provided for relieving tank pressure before the device is operated.

5.2.2 Separate ullage openings may be fitted as a reserve means for sounding cargo tanks.

5.2.3 Arrangements which permit the escape of vapour to the atmosphere are not to be fitted in enclosed spaces.

5.3 Closed sounding devices

5.3.1 In all tankers fitted with a fixed inert gas system, the cargo tanks are to be fitted with closed sounding devices of an approved type, which do not permit the escape of cargo to the atmosphere when being used.

5.3.2 Proposals to use indirect sounding or measuring devices which do not penetrate the tank plating will be specially considered.

■ **Section 6**
Cargo heating arrangements

6.1 General

6.1.1 Where heating systems are provided for the cargo tanks, the arrangements are to comply with the requirements of *Pt 5, Ch 15, 6.2 Blanking arrangements* to *Pt 5, Ch 15, 6.5 Temperature indication*.

6.2 Blanking arrangements

6.2.1 Spectacle flanges of spool pieces are to be provided in the heating medium supply and return pipes to the cargo heating system, at a suitable position within the cargo area, so that lines can be blanked off in circumstances where the cargo does not require to be heated or where the heating coils have been removed from the tanks. Alternatively, blanking arrangements may be provided for each tank heating circuit.

6.3 Heating medium

6.3.1 Where a combustible liquid is used as the heating medium it is to have a flash point of 60°C or above (closed-cup test).

6.3.2 In general, the temperature of the heating medium is not to exceed 220°C, *see Pt 5, Ch 15, 1.5 Hazardous zones and spaces*.

6.4 Heating circuits

6.4.1 The heating medium supply and return lines are not to penetrate the cargo tank plating, other than at the top of the tank, and the main supply lines are to be run above the weather deck.

6.4.2 Isolating shut-off valves or cocks are to be provided at the inlet and outlet connections to the heating circuit(s) of each tank, and means are to be provided for regulating the flow.

6.4.3 Where steam or water is employed in the heating circuits, the returns are to be led to an observation tank which is to be in a well ventilated and well lighted part of the machinery space remote from the boilers.

6.4.4 Where a thermal oil is employed in the heating circuits, the arrangements will be specially considered but, in any case, they are to be such that contamination of the thermal oil with cargo liquid cannot take place under normal operating conditions. In general, the arrangements are, at least, to comply with *Pt 5, Ch 15, 3.7 Remote control valves 3.7.8*, in so far as they are applicable.

6.4.5 In any heating system, a higher pressure is to be maintained within the heating circuit than the maximum pressure head which can be exerted by the contents of the cargo tank on the circuit. Alternatively, when the heating circuit is not in use, it may be drained and blanked.

6.5 Temperature indication

6.5.1 Means are to be provided for measuring the cargo temperature. Where overheating could result in a dangerous condition, an alarm system which monitors the cargo temperature is to be provided.

■ Section 7

Inert gas systems on Tankers of 8,000 tonnes DWT and above

7.1 General

7.1.1 An inert gas system complying with the applicable requirements of Chapter 15 of the FSS code as amended by *Resolution MSC.367(93) – Amendments to the International Code for Fire Safety Systems (FSS Code) – (Adopted on 22 May 2014)*, is to be fitted on tankers of 8,000 tonnes DWT and above. For purposes of classification any use of the word "Administration" in the Regulation is to be taken as meaning LR. See *Pt 5, Ch 15, 7.7 Nitrogen generator systems* for additional requirements for inert gas systems utilising nitrogen.

7.1.2 Ships complying with these requirements will be eligible for the additional notation **IGS** in the *Register Book*, see *Pt 1, Ch 2 Classification Regulations*.

7.1.3 Throughout this Section the term 'cargo tank' includes also 'slop tanks'. For definition of Machinery spaces of Category 'A', see SOLAS Reg. II-2/ *Part A - General*.

7.2 Gas supply

7.2.1 The inert gas may be treated flue gas from the main or auxiliary boiler(s) gas turbine(s), or from a separate inert gas generator. In all cases, automatic combustion control, capable of producing suitable inert gas under all service conditions, is to be fitted.

7.3 Venting arrangements

7.3.1 The arrangements for the venting of all vapours displaced from the cargo tanks during loading and ballasting are to comply with *Pt 5, Ch 15, 4 Cargo tank venting, purging and gas-freeing* and are to consist of either one or more mast risers, or a number of high velocity vents. The inert gas supply mains may be used for such venting.

7.3.2 The arrangements for inerting, purging or gas freeing of empty tanks as required in by 2.2.1.2.1 to .3 of *Chapter 15 - Inert Gas Systems*, as amended by *Resolution MSC.367(93) – Amendments to the International Code for Fire Safety Systems (FSS Code) – (Adopted on 22 May 2014)* are to be such that the accumulation of hydrocarbon vapours in pockets formed by the internal structural members in a tank is minimised and that:

- (a) on individual cargo tanks the gas outlet pipe, if fitted, is to be positioned as far as practicable from the inert gas/air inlet and in accordance with *Pt 5, Ch 15, 4 Cargo tank venting, purging and gas-freeing*. The inlet of such outlet pipes may be located either at deck level or at not more than 1 m above the bottom of the tank;
- (b) the cross-sectional area of such gas outlet pipes referred to in *Pt 5, Ch 15, 7.3 Venting arrangements 7.3.2* is to be such that an exit velocity of at least 20 m/s can be maintained when any three tanks are being simultaneously supplied with inert gas. Their outlets are to extend not less than 2 m above deck level;
- (c) each gas outlet referred to in *Pt 5, Ch 15, 7.3 Venting arrangements 7.3.2* is to be fitted with suitable blanking arrangements;

7.3.3 One or more pressure-vacuum breaking devices are to be provided to prevent the cargo tanks from being subject to:

- (a) a positive pressure in excess of the test pressure of the cargo tank if the cargo were to be loaded at the maximum rated capacity and all other outlets were left shut; and
- (b) a negative pressure in excess of 700 mm water gauge if cargo were to be discharged at the maximum rated capacity of the cargo pumps and the inert gas blowers were to fail.

Such devices shall be installed on the inert gas main unless they are installed in the venting system required by *Pt 5, Ch 15, 4 Cargo tank venting, purging and gas-freeing* or on individual cargo tanks.

7.3.4 The location and design of the devices referred to in *Pt 5, Ch 15, 7.3 Venting arrangements 7.3.3* are to be in accordance with *Pt 5, Ch 15, 4 Cargo tank venting, purging and gas-freeing*.

7.4 Unattended machinery

7.4.1 Where inert gas generators are fitted with automatic or remote controls so that under normal operating conditions they do not require any manual intervention by the operators, they are to be provided with the alarms and safety arrangements required by *Pt 5, Ch 15, 7.4 Unattended machinery 7.4.2, Pt 5, Ch 15, 7.4 Unattended machinery 7.4.3, Pt 5, Ch 15, 7.5 Instrumentation and alarms* and *Pt 5, Ch 15, 7.7 Nitrogen generator systems*, as appropriate. Alternative arrangements which provide equivalent safeguards will be considered.

7.4.2 Where machinery is arranged to start automatically or from a remote control station, interlocks are to be provided to prevent start-up under conditions which could hazard the machinery.

7.4.3 Where machinery specified in *Pt 5, Ch 15, 7.4 Unattended machinery 7.4.1* and *Pt 5, Ch 15, 7.4 Unattended machinery 7.4.2* is required to be provided with a standby pump, the standby pump is to start automatically if the discharge pressure from the working pumps falls below a predetermined value.

7.5 Instrumentation and alarms

7.5.1 Alarms and safeguards are to be provided in accordance with 2.2.4 and 2.3.2 of the FSS Code as amended by *Resolution MSC.365(93) – Amendments to the International Convention For the Safety of Life at Sea, 1974, as amended – (Adopted on 22 May 2014)* and *Table 15.7.1 Inert gas systems – Alarms and safeguards*.

Table 15.7.1 Inert gas systems – Alarms and safeguards

Item	Alarm	Note
Combustion air pressure to oil burner	Low	1
Fuel oil pressure	Low	-
Fuel oil temperature or viscosity	High and Low	3
Burner flame and ignition	Failure	1, 2
Cooling water temperature	High	-
Automatic control system power supply	Failure	-
<p>Note 1 Combustion spaces are to be purged automatically before re-ignition takes place in the event of a flame out on all burners.</p> <p>Note 2 Fuel oil to burner to be shut off automatically.</p> <p>Note 3 Heavy oil only.</p> <p>Note 4 Additional alerts and shutdowns may be necessary as determined through risk-mitigating activities in response to the completed Risk-Based Analysis (e.g. FMECA) for the inert gas generator.</p>		

7.5.2 Inert gas generators are to be fitted with an automatic combustion control system so as to maintain steady state conditions throughout the operating range of the generator.

7.5.3 See also *Pt 6, Ch 1 Control Engineering Systems* for requirements for control, alarm and safety systems.

7.6 Installation and tests

7.6.1 The inert gas system, including alarms and safety devices, is to be installed on board and tested under working conditions to the satisfaction of the Surveyors.

7.7 Nitrogen generator systems

7.7.1 The following requirements apply where a nitrogen generator system is fitted on board Tankers of 8,000 tonnes DWT and above. For the purpose, the inert gas is to be produced by separating air into its component gases by passing compressed air through a bundle of hollow fibres, semi-permeable membranes or adsorber materials.

7.7.2 Alarms and safeguards are to be provided in accordance with 2.2.4 and 2.3.2 of the FSS Code as amended by *Resolution MSC.365(93) – Amendments to the International Convention For the Safety of Life at Sea, 1974, as amended – (Adopted on 22 May 2014)* and *Table 15.7.2 Nitrogen generator systems – Alarms and safeguards*.

Table 15.7.2 Nitrogen generator systems – Alarms and safeguards

Item	Alarm	Note
Oxygen content	High	1, 2, 3
Power supply to oxygen content monitoring instrumentation downstream of Nitrogen generator	Failure	1

Note 1 To be fitted in the machinery space and cargo control room, where provided.

Note 2 Oxygen content not to exceed 5% with automatic discharge to atmosphere where this is exceeded, see *Pt 5, Ch 15, 7.7 Nitrogen generator systems 7.7.5*.

Note 3 Automatic shutdown of inert gas generating system.

Note 4 The Table contains the minimum list of alerts and shutdowns for an inert gas generator and is in addition to 2.2.4 and 2.4.2 of the FSS Code as amended by *Resolution MSC.365(93) – Amendments to the International Convention For the Safety of Life at Sea, 1974, as amended – (Adopted on 22 May 2014)*; additional alerts and shutdowns may be necessary as determined through risk-mitigating activities in response to the completed Risk-Based Analysis (e.g. FMECA) for the inert gas generator.

7.7.3 In addition to the applicable requirements of *Chapter 15 - Inert Gas Systems*, as amended by *Resolution MSC.367(93) – Amendments to the International Code for Fire Safety Systems (FSS Code) – (Adopted on 22 May 2014)*, the nitrogen generator system is to comply with SOLAS regulations *II-2/ 5.3 Cargo tank venting, 5.6 Inerting, purging and gas-freeing* and *6 Protection of cargo tank structure against pressure or vacuum in tankers*.

7.7.4 A nitrogen generator consisting of a feed air treatment system and any number of membrane or adsorber modules in parallel is to be capable of delivering nitrogen to the cargo tanks at the rate required by paragraph 2.2.1.2.4 of *Chapter 15 - Inert Gas Systems*, as amended by *Resolution MSC.367(93) – Amendments to the International Code for Fire Safety Systems (FSS Code) – (Adopted on 22 May 2014)*.

7.7.5 The nitrogen generator is to be capable of delivering high purity nitrogen with an oxygen content in accordance with paragraph 2.2.1.2.5 of Ch 15 of the FSS Code, as amended by MSC.367(93). In addition to meeting the venting requirements of paragraph 2.2.2.4 of Ch 15 of the FSS Code, as amended by MSC.367(93), the system is to be fitted with automatic means to discharge “off-spec” gas to the atmosphere during start-up and abnormal operation.

7.7.6 The system is to be provided with one or more compressors to generate enough positive pressure to be capable of delivering the total volume of gas required by 2.2.1.2 of the FSS Code, as amended by MSC.367(93). Where two compressors are provided, the total required capacity of the system is preferably to be divided equally between the two compressors, and in no case is one compressor to have a capacity less than 1/3 of the total capacity required.

7.7.7 Where the nitrogen system includes a nitrogen storage tank which has sufficient capacity to deliver the total volume of gas required by 2.2.1.2 of the FSS Code, as amended by *Resolution MSC.367(93) – Amendments to the International Code for Fire Safety Systems (FSS Code) – (Adopted on 22 May 2014)*, in the event of failure of a compressor a single compressor may be accepted provided that sufficient spares are carried on board to enable the failure to be rectified by the ship’s crew. The list of spare parts required is to be supplied by the manufacturer and supported by a reliability analysis of the specific system submitted to and verified by LR. The size of the nitrogen storage tank is to be specified.

7.7.8 The feed air treatment system fitted to remove free water, particles and traces of oil from the compressed air as required by 2.4.1.2 of *Chapter 15 - Inert Gas Systems*, as amended by *Resolution MSC.367(93) – Amendments to the International Code for Fire Safety Systems (FSS Code) – (Adopted on 22 May 2014)*, is also to maintain the specification temperature.

7.7.9 The oxygen-enriched air from the nitrogen generator and the nitrogen-product enriched gas from the protective devices of the nitrogen receiver are to be arranged to discharge to a safe location on the open deck. This safe location needs to address the two types of discharges separately.

For oxygen-enriched air from the nitrogen generator, safe locations on the open deck are:

- outside of hazardous areas as defined by *Pt 6, Ch 2, 13.5 Discharge lighting*;
- not within 3 m of areas traversed by personnel;
- not within 6 m of air intakes for machinery and all ventilation inlets.

For nitrogen-product enriched gas from the protective devices of the nitrogen receiver, safe locations on the open deck are:

- not within 3 m of areas traversed by personnel;
- not within 6 m of air intakes for machinery and all ventilation inlets/outlets.

7.7.10 In order to permit maintenance, means of isolation are to be fitted between the generator and the receiver.

7.8 Nitrogen/inert gas systems fitted for purposes other than inerting required by SOLAS Reg. II-2/4.5.5.1

7.8.1 This section applies to systems fitted on oil tankers to which SOLAS regulation II- 2/4.5.5.1 does not apply.

7.8.2 The requirements given in *Chapter 15 - Inert Gas Systems, 2.2.2, 2.2.4, 2.4.1 and 2.4.2* of the FSS Code, as amended by *Resolution MSC.367(93) – Amendments to the International Code for Fire Safety Systems (FSS Code) – (Adopted on 22 May 2014)*, apply to the systems as applicable.

7.8.3 The requirements of *Pt 5, Ch 15, 7.7 Nitrogen generator systems* apply except *Pt 5, Ch 15, 7.7 Nitrogen generator systems 7.7.1, Pt 5, Ch 15, 7.7 Nitrogen generator systems 7.7.3, Pt 5, Ch 15, 7.7 Nitrogen generator systems 7.7.4, Pt 5, Ch 15, 7.7 Nitrogen generator systems 7.7.6 and Pt 5, Ch 15, 7.7 Nitrogen generator systems 7.7.7*.

7.8.4 Materials used in inert gas systems are to be suitable for their intended purpose in accordance with the LR Rules for Materials.

7.8.5 All the equipment is to be installed on board and tested under working conditions to the satisfaction of the Surveyor.

7.8.6 The two non-return devices as required by paragraph 2.2.3.1.1 of *Chapter 15 - Inert Gas Systems*, as amended by *Resolution MSC.367(93) – Amendments to the International Code for Fire Safety Systems (FSS Code) – (Adopted on 22 May 2014)* are to be fitted in the inert gas main. The non-return devices are to comply with 2.2.3.1.2 and 2.2.3.1.3 of *Chapter 15 - Inert Gas Systems*, as amended by *Resolution MSC.367(93) – Amendments to the International Code for Fire Safety Systems (FSS Code) – (Adopted on 22 May 2014)*; however, where the connections to the cargo tanks, to the hold spaces or to cargo piping are not permanent, the non-return devices required by paragraph 2.2.3.1.1 of *Chapter 15 - Inert Gas Systems*, as amended by *Resolution MSC.367(93) – Amendments to the International Code for Fire Safety Systems (FSS Code) – (Adopted on 22 May 2014)*, may be substituted by two non-return valves.



Cross-reference

For vapour detection, see also *Ch 1, 13.2 Vapour detection* of the *Rules and Regulations for the Construction and Classification of Ships for the Carriage of Liquid Chemicals in Bulk*.

Section

-
- 1 **Scope**
 - 2 **General requirements**
 - 3 **Design requirements**
 - 4 **Piping systems**
 - 5 **Control and monitoring**
 - 6 **Electrical systems**
 - 7 **Inspection, testing and fitting of water jets**
 - 8 **Installation, maintenance and replacement**
-

■ *Section 1*
Scope

1.1 General

1.1.1 For the purposes of these Rules, a water jet propulsion unit is described as a machine which takes in water, by means of a suitable inlet and conduit and accelerates the mass of water using an impeller and nozzle to form a jet propulsion system. The water jet system comprises the unit and its associated actuation and control devices. The detail of the prime mover is excluded but not its effect on the water jet system.

1.1.2 This Chapter defines the requirements for the design and service life of marine water jet propulsion systems and is to be read in conjunction with the General Requirements for the Design and Construction of Machinery in *Pt 5, Ch 1 General Requirements for the Design and Construction of Machinery*.

1.1.3 The requirements for a fixed or steerable water jet propulsion system rated at 500 kW and above, which is integral with the ship's hull structure and forms a means of main propulsion, are detailed in this Chapter. This includes support arrangements, controls and the systems necessary to maintain operation and functionality of the water jet unit.

1.1.4 These requirements relate to water jets driven by axial or mixed flow pumps. Where units driven by radial flow pumps or inducers are proposed, details are to be submitted for consideration.

■ *Section 2*
General requirements

2.1 Water jet arrangement

2.1.1 In general, for a ship to be assigned an unrestricted service notation, a minimum of two water jet systems are to be provided where these form the sole means of propulsion. For ships where a single water jet system is the sole means of propulsion or steering, a detailed engineering and safety justification is to be evaluated by LR, *see Pt 5, Ch 16, 2.3 Calculations and information 2.3.22*. This evaluation process will include a risk assessment analysis using a recognised technique to verify that sufficient levels of redundancy and monitoring are incorporated in the water jet unit's essential support systems and operating equipment.

2.1.2 water jet propulsion units are to be capable of continuous operation between their maximum and minimum output power rating at specified operating conditions, *see Pt 5, Ch 1, 3 Operating conditions* and within the operational service profiles defined by *Pt 5, Ch 16, 2.3 Calculations and information 2.3.11* and *Pt 5, Ch 16, 2.3 Calculations and information 2.3.12*.

2.1.3 It is the Shipbuilder's responsibility to ensure that all of the installed equipment is suitable for operation in the location and under the environmental conditions defined in *Pt 5, Ch 1 General Requirements for the Design and Construction of*

Machinery. Where anticipated environmental conditions are outside these limits or where additional conditions are to be considered, such as vibration and impulsive accelerations, requirements and details of compliance are to be submitted to LR.

2.2 Plans to be submitted

2.2.1 Plans, in triplicate, and information as detailed below and in *Pt 5, Ch 16, 2.3 Calculations and information* and *Pt 5, Ch 16, 2.4 Failure Mode and Effects Analysis (FMEA)*, are to be submitted for consideration.

2.2.2 General arrangement plans showing details of the following:

- (a) Shafting assembly indicating bearing positions.
- (b) Steering assembly.
- (c) Reversing assembly.
- (d) Shaft sealing arrangement assembly.
- (e) Longitudinal section of the complete water jet unit.

2.2.3 Detailed and dimensioned plans indicating scantlings, materials of construction and where applicable surface finish of the following:

- (a) Arrangement of the system, including the intended method of attachment to the hull and building-in, tunnel geometry, shell openings, method of stiffening, reinforcement, etc.
- (b) All torque transmitting components, including the shafting system, impeller and stator if fitted.
- (c) Steering components, together with a description and line diagram of the control circuit. This is to include steerable exit water jet nozzles where fitted.
- (d) Components of the retractable buckets where these are used for providing astern thrust.
- (e) The bearing or bearings absorbing the thrust and supporting the impeller, together with the method of lubrication.
- (f) Details of any shafting support or guide vanes used in the water jet system.

2.2.4 Schematic plans of the lubrication and hydraulics required for steering/reversing systems, together with pipe material, relief valves and the working pressures required.

2.3 Calculations and information

2.3.1 Strength calculations based on fatigue considerations incorporating the maximum continuous torque rating and the most 'onerous' operating condition, see *Pt 5, Ch 16, 2.3 Calculations and information 2.3.12*, including any short-term high power operation, and including the effects of mean and fluctuating loads, transitory loadings, residual stress allowances, and stress raisers, for the following components:

- (a) Impeller, stator and any bolting arrangements supporting propulsion or steering loads.
- (b) Shaft supports and coupling arrangements.
- (c) Inlet guide vanes, if fitted.
- (d) Steering components, including the lugs of steerable nozzles where fitted.
- (e) Retractable buckets and associated mechanisms which are used to provide astern thrust. A calculation of the hydrodynamic transient loads is to be made for each design and is to include the full ahead to full astern condition. The calculation procedure used is to be supported, where possible, with full scale or model test data, or satisfactory service experience, to validate the design method.

2.3.2 Calculations supporting the connection method of the impeller to the shaft, including details of the fit, push-up, securing, bolting arrangements, etc. In addition, where lengths of shafts are joined using couplings of the shrunk element type, full particulars of the method of achieving the grip force.

2.3.3 Calculations relating to the design of the shaftline as evidence of compliance with *Pt 5, Ch 6 Main Propulsion Shafting*.

2.3.4 Torsional vibration calculations of the complete dynamic system in accordance with the relevant requirements included in *Pt 5, Ch 8 Shaft Vibration and Alignment*.

2.3.5 Shaft lateral vibration calculations where required by *Pt 5, Ch 8 Shaft Vibration and Alignment*.

2.3.6 Calculations of the tunnel strength and supporting structure.

2.3.7 A calculation to determine the stresses within the impeller blade.

2.3.8 A calculation of the blade natural frequency for the impeller blades.

- 2.3.9 A calculation of the relative blade passing frequency between the rotor and stator blades.
- 2.3.10 The value of the fluctuating stresses during one revolution of the impeller and from transient loadings.
- 2.3.11 Details of the power/speed range of operation, indicating the maximum continuous torque rating, together with the associated thrusts; this information may be presented in the form of a characteristic curve for the water jet.
- 2.3.12 The water jet thrust for the assessment of the strength condition being considered is to be as follows:
- For ships which are intended to operate predominantly in a free-running condition and at steady service conditions, the water jet thrust is to correspond to the absorption of the maximum continuous shaft power and corresponding revolutions per minute, giving the maximum torque for which the shaft system is approved.
 - For ships which are designed for several operating conditions, the maximum thrust associated with these conditions and the absorption of the corresponding power, in addition to the maximum continuous powering condition, are to be used in the calculation.
 - The justification for the thrust selected is to be submitted for consideration in the approval process and this is to include the ship type and the ship speed at the conditions considered.
- 2.3.13 A justification that the water jet system will meet the self-priming criteria, see *Pt 5, Ch 16, 3.1 General 3.1.6*.
- 2.3.14 Specifications of materials and NDE procedures for components essential for propulsion and steering operation and, in the case of the impeller and stator, the yield strength and the fatigue characteristics of the material intended for their manufacture.
- 2.3.15 A detailed weld specification where an impeller has welded blades.
- 2.3.16 Full details of the means of corrosion protection in the case of carbon or carbon manganese steel shafts. Alternatively, where it is proposed to use composite shafts, details of the connections at flanges, materials, resin, lay-up procedures, quality control procedures and documentary evidence of fatigue endurance strength is to be provided.
- 2.3.17 Dry impeller mass and polar moment of inertia.
- 2.3.18 The prime mover type and designation.
- 2.3.19 Details of the control engineering aspects of the system design in accordance with *Pt 6, Ch 1 Control Engineering Systems*.
- 2.3.20 The tolerance specification, agreed between the manufacturer and the Shipbuilder or Owner, to which the components of the unit are to be manufactured is to be defined, together with a justification.
- 2.3.21 Details of the water jet's loading reactions together with the positions of application within the hull and is to include the maximum applied thrust, tunnel pressures, moments and forces imposed on the ship.
- 2.3.22 The water jet unit's rated flow and head.
- 2.3.23 Where an engineering and safety justification report is required, the following supporting information is to be submitted:
- A Failure Mode and Effects Analysis report (FMEA), see *Pt 5, Ch 16, 2.4 Failure Mode and Effects Analysis (FMEA)*.
 - Design standards and assumptions.
 - Limiting operating parameters.
 - A statement and evidence in respect of the anticipated reliability of any non-duplicated components.
- 2.3.24 Recommended installation, inspection, maintenance and component replacement procedures. This is to include any in-water engineering procedures where recommended by the water jet manufacturer.
- 2.3.25 All transient loads which the steering unit is likely to experience from manoeuvring, accelerating, decelerating and the sea conditions.

2.4 Failure Mode and Effects Analysis (FMEA)

- 2.4.1 An FMEA is to be carried out where a single water jet system is the ship's sole means of propulsion, see *Pt 5, Ch 16, 2.2 Plans to be submitted 2.2.3*. The FMEA is to identify components where a single failure could cause the loss of all propulsion and/or steering capability, and the proposed arrangements for preventing and mitigating the effects of such a failure.
- 2.4.2 The FMEA is to be carried out using the format presented in *Table 22.2.1 Failure Mode and Effects Analysis* in Chapter 22 or an equivalent format that addresses the same reliability issues. Analyses in accordance with IEC 60812 *Analysis for System Reliability – Procedure for Failure Mode and Effects Analysis*, or the IMO Code of Safety for High Speed Craft, 2000, Annex 4 – *Procedures for Failure Mode and Effects Analysis*, would be acceptable.

2.4.3 The FMEA is to be organised in terms of equipment and function. The effects of item failures at a stated level and at higher levels are to be analysed to determine these effects on the system as a whole. Actions for mitigation of the effects of failure are to be determined, see *Pt 5, Ch 16, 2.4 Failure Mode and Effects Analysis (FMEA) 2.4.1*.

2.4.4 The FMEA is to:

- (a) identify the equipment or sub-system and mode of operation;
- (b) identify potential failure modes and their causes;
- (c) evaluate the effects on the system of each failure mode;
- (d) identify measures for reducing the risks associated with each failure mode;
- (e) identify measures for preventing failure; and
- (f) identify trials and testing necessary to prove conclusions.

2.4.5 At sub-system level it is acceptable, for the purpose of these Rules, to consider failure of equipment items and their functions. It is not required that the failure of components within that equipment item be analysed, see *Pt 5, Ch 22, 2.1 General 2.1.5*.

2.4.6 Where a FMEA is used for consideration of systems that depend on software-based functions for control or co-ordination, the analysis is to investigate failure of the functions rather than a specific analysis of the software code itself.

■ Section 3 Design requirements

3.1 General

3.1.1 The arrangement of water jet units is to be such that the ship can be satisfactorily manoeuvred to a declared performance capability. The operating conditions covered are to include the following:

- (a) Maximum continuous shaft power/speed to the impeller in the ahead condition at the declared steering angles and conditions.
- (b) Manoeuvring speeds of the impeller shaft and/or reversing mechanism in the ahead and astern direction at the declared steering angles and sea conditions.
- (c) The stopping manoeuvre described in *Pt 5, Ch 1, 5.2 Sea trials 5.2.2*.
- (d) Astern running conditions for the ship.

3.1.2 The mean loadings are those loadings induced by the water jet absorbing the mean torque supplied by the prime mover.

3.1.3 Fluctuating loads are defined as those loads which occur during one revolution of the impeller due to cyclic variations. For example, the spatial flow variations and torsional vibration at nominally steady state operating conditions.

3.1.4 Transient loads are defined as those loadings resulting from acceleration and deceleration of the ship, manoeuvring, seaway conditions and other similar forms of loading. This also includes any significant back-pressure effects developed from the operation of the reversing bucket, if fitted.

3.1.5 To ensure self-priming of the water jet unit, the shaft centreline of the unit is to be lower than the light draught static waterline of the ship. In cases where this is either impracticable or undesirable, the distance of the impeller shaft centreline above the ship's light draught waterline is to be less than or equal to 10 per cent of the pump inlet diameter.

3.1.6 Provision is to be made to allow for the in-service visual inspection of the complete blade surfaces of both the impeller and stator blades using either a direct visual or borescope inspection technique.

3.2 Shaftline

3.2.1 The diameter of the shaftline components are to comply with *Pt 5, Ch 6 Main Propulsion Shafting*. For calculation purposes the shaft carrying the impeller is to be taken as equivalent to a screwshaft.

3.2.2 Where it is proposed to use carbon or carbon manganese steel shafts which may be in contact with seawater, these are to be protected.

3.2.3 The diameter of unprotected screwshafts of corrosion-resistant material is not to be less than that given in *Pt 11, Ch 2, 4.4 Screwshafts and tube shafts 4.4.7* of the *Rules and Regulations for the Classification of Special Service Craft*.

3.2.4 The use of composite shafts is permitted, see *Pt 5, Ch 16, 2.3 Calculations and information 2.3.16*.

3.2.5 Where lengths of shafts are joined using couplings of the shrunk element type, a factor of safety, based upon the mean plus the vibratory and transient torques, against slippage of 2,0 is to be achieved for couplings which are located inboard and 2,5 for couplings which are located outboard.

3.2.6 Where shaftline components are bolted together, a factor of safety of 1,5 is to be achieved for the design of the bolted connection when considered in the context of the mean, fluctuating and transitory loadings.

3.2.7 If a keyed fitting of the impeller to the shaft is contemplated, then the requirements of *Pt 5, Ch 6, 3.10 Keys and keyways* are to be satisfied.

3.2.8 Where it is proposed to fit a keyless impeller, the fitting is to comply with the requirements of *Pt 5, Ch 7, 3.2 Keyless propellers*, as applicable, excluding the requirements for Ice Class. Use of the words 'propeller' and 'screwshaft' are to be taken as meaning 'impeller' and 'impellershaft' respectively.

3.3 Shaft support system and guide vanes

3.3.1 In cases where the shaft requires support from the tunnel walls ahead of the impeller or, alternatively, where guide vanes are required to assist the flow around a bend in the ducting system, the supports or guide vanes are to be suitably aligned to the flow and have suitably rounded leading and trailing edges or be of an aerofoil section.

3.3.2 In general, the fillet radius should be greater than or equal to the maximum thickness of the vane or support at that location. Smaller radii may be considered for which the results of an approved measurement programme or calculation procedure are to be submitted. In all cases, a factor of safety of at least 1,5 is to be demonstrated for the maximum designed operating conditions.

3.3.3 A facility for the inspection of the supports or guide vanes is to be provided which will allow either direct visual or borescope inspection of these components and their transition to other members.

3.4 Impeller

3.4.1 A calculation to determine the stresses within the impeller blades is to be carried out, which takes into account the mean blade loading, fluctuating loadings, transient loads and centrifugal force. The computations may be accomplished by either classical methods or numerical analysis. Designs of water jet systems which have been based on a combination of computational fluid dynamics and finite element methods will be considered. However, it will be necessary to demonstrate to the satisfaction of LR that the formulation of the methods used has been correlated with previous full scale measurement or other calculation experience.

3.4.2 For the purposes of the calculation required by this sub-Section, the fluctuating stresses during one revolution of the impeller is to be taken as 20 per cent of the maximum mean stress, and the stresses from transient loadings are to be taken as 15 per cent of the hydrodynamic mean stress, unless otherwise specified by the designer.

3.4.3 The fatigue assessment of the impeller blades is to be based on the stress in the root sections, excluding the influence of the blade root fillets. This assessment is to include the following components:

- the maximum stresses derived from the mean loading, including both the hydrodynamic and centrifugal components;
- the amplitude of the fluctuating stresses during one revolution of the impeller;
- the stresses derived from transient loading and an allowance for any residual stresses in the material.

It is permissible to combine the variable components of stress in a linear fatigue damage accumulation assessment procedure. A factor of safety of at least 1,5 against fatigue failure is to be demonstrated for the maximum continuous rating condition or any other more onerous condition, see *Pt 5, Ch 16, 3.1 General 3.1.1*.

3.4.4 In general, the fillet radius is to be greater than the maximum thickness of the impeller blade at that location. Composite radiused fillets or elliptical fillets which provide an improved stress concentration factor are preferred.

3.4.5 Where an impeller has bolted-on blades, consideration is to be given to the distribution of stress in the palms of the blade and in the boss and bolting arrangements.

3.4.6 Where an impeller has welded blades the welds are to be of the full penetration type or of equivalent strength. Where laser welding is to be used, details are to be submitted for consideration.

3.4.7 The blades are to be provided with hydrodynamically faired leading and trailing edges which may be either of simple radius or of a more complex aerofoil edge form. The tip clearance, whilst being kept to a minimum for hydrodynamic purposes, is to be sufficient to allow for any transient vibrational behaviour, axial shaft movement or differential thermal expansion.

3.4.8 A calculation of the blade natural frequency for the impeller blades is to be undertaken. The fundamental natural frequency in water of the blade is to be shown to lie outside any expected excitation frequencies within a speed range of the water jet unit and up to 10 per cent above the maximum impeller speed.

3.5 Stator

3.5.1 The stator blades, where fitted, are to be designed to be capable of withstanding the combined hydrodynamic mean, fluctuating, transient and mechanical loads, including any loads transmitted via shaft bearings, developed by the unit and reacted through the blades when the impeller is absorbing full power. Consideration is to be given to situations when the vessel is either free running or in a condition specified by *Pt 5, Ch 16, 3.1 General 3.1.1* or undergoing stopping, accelerating or decelerating manoeuvres. A factor of safety against mechanical failure by yielding of the blades of 1,5 is to be demonstrated.

3.5.2 In general, the fillet radius is to be greater than the maximum thickness of the blade at that location. Composite radiused fillets or elliptical fillets which provide improved stress concentration factors are preferred.

3.5.3 If the stator ring comprises a segmented assembly, then consideration is also to be given to the distribution of stress in the various adjacent members of the overall assembly.

3.5.4 A calculation of the relative blade passing frequency between the rotor and stator blades is to demonstrate that this does not coincide with the natural frequency of the stator blades over the speed range of the water jet unit and up to 10 per cent above maximum impeller speed.

3.5.5 The stator blades are to be provided with hydrodynamically faired leading edges which may have either a simple radius or a more complex aerofoil edge form.

3.5.6 Where the stator blading assembly forms part of the nozzle, the requirements of *Pt 5, Ch 16, 3.7 Nozzle/steering arrangements* are to be considered in association with those for the stator assembly.

3.6 Tunnel and securing arrangements

3.6.1 The tunnel is to be adequately supported, framed and fully integrated into the hull structure. The critical locations and integrity of the supports and framing are to be as specified in the FMEA and agreed by the Shipbuilder and LR.

3.6.2 The tunnel and supporting structure scantlings are to be not less than the Rule requirements for the surrounding structure. The strength of the hull structure in way of tunnel(s) is to be maintained. The structure is to be adequately reinforced and compensated as necessary. All openings are to be suitably reinforced and have radiused corners.

3.6.3 Consideration is to be given to providing the inlet to the tunnel with a suitable guard to prevent the ingress of large objects into the rotodynamic machinery. The dimensions of this guard, if fitted, are to strike a balance between undue efficiency loss due to flow restriction and viscous losses, the size of object allowed to pass and the susceptibility to clog with weed and other flow-restricting matter.

3.6.4 The inlet profile of the tunnel is to be designed so as to provide a smooth uptake of the water over the range of vessel operating trims and avoid significant separation and/or cavitation of the flow which may then pass downstream into the rotating machinery.

3.6.5 Design consideration is to take account of pressures which could develop as a result of a duct blockage as well as in relation to the axial location of rotating parts.

3.6.6 The strength of the tunnel and supporting structure are to be examined by direct calculation procedures.

3.7 Nozzle/steering arrangements

3.7.1 In general, the steering systems and components are to comply with the requirements of *Pt 5, Ch 19 Steering Arrangements*. The requirements of *Pt 5, Ch 19, 2.1 General 2.1.2* and *Pt 5, Ch 19, 2.1 General 2.1.2* are addressed by *Pt 5, Ch 16, 3.7 Nozzle/steering arrangements 3.7.3* and the requirements of *Pt 5, Ch 19, 2.1 General 2.1.3* and *Pt 5, Ch 19, 2.1 General 2.1.3* are addressed by *Pt 5, Ch 16, 3.7 Nozzle/steering arrangements 3.7.4*

3.7.2 For vessels with more than one steerable water jet, the requirement for auxiliary steering arrangements in *Pt 5, Ch 19, 2 Performance* is to be achieved by equipping each of the steerable water jets with its own dedicated and independent steering gear

control system and power actuating system. Consideration will be given to alternative arrangements providing equivalence can be demonstrated.

3.7.3 The main steering arrangements are to be operated by power and capable of changing the direction of the ship's water jet nozzles from one side to the other at declared steering angle limits at an average rotational speed of not less than 0,4 rev/min, with the ship running ahead at maximum ahead service speed.

3.7.4 The auxiliary steering arrangements are to be:

- (a) Capable of changing the direction of the ship's water jet nozzles from one side to the other at declared steering angle limits at an average rotational speed of not less than 0,083 rev/min, with the ship running ahead at one half of the maximum ahead service speed or 7 knots, whichever is the greater.
- (b) Operated by power for ships having propulsion power of more than 2500 kW per water jet unit and for all ships, where it is necessary, to meet the requirements of *Pt 5, Ch 16, 3.7 Nozzle/steering arrangements 3.7.4*.

3.7.5 Nozzles can be either of a fixed or steerable form. The design of the nozzle is to take into account fully the change in pressure distribution along its inner surface together with the other mechanical loads (e.g. stator assembly loads) and transient loads caused by the flow-directing attachments which may be reacted through the body of the nozzle. In this analysis the changes to the pressure distribution caused by transient manoeuvres are to be considered.

3.7.6 In addition to the requirements of *Pt 5, Ch 19 Steering Arrangements*, the steering mechanism and bucket are to be capable of maintaining the manoeuvrability of the ship in terms of turning circle, zig-zag and stopping requirements within the limits defined by *IMO Resolution MSC.137(76) - Standards for Ship Manoeuvrability - (adopted on 4 December 2002)*.

3.7.7 Consideration is to be given to all transient loads which the steering unit is likely to experience from manoeuvring, accelerating, decelerating and the sea conditions.

3.7.8 The nozzle/bucket is to be given mechanical protection by the Shipbuilder from other impact damage such as collision.

3.8 Bolts

3.8.1 Detailed consideration and analysis is to be given to essential bolting arrangements in critical locations as specified in the FMEA and where indicated by the manufacturer or Shipbuilder and agreed by LR. These are to include; bolts used in the securing of blades or guide vanes, assembly of the unit in the ship and any conduit components.

■ *Section 4* **Piping systems**

4.1 General

4.1.1 The piping systems for a water jet unit are to comply with the general requirements of *Pt 5, Ch 12 Piping Design Requirements*.

4.1.2 Lubricating and hydraulic oil systems and standby arrangements are to comply with the requirements of *Pt 5, Ch 14 Machinery Piping Systems*; in addition, steering hydraulic systems are to comply with the applicable requirements of *Pt 5, Ch 19 Steering Arrangements*.

■ *Section 5* **Control and monitoring**

5.1 General

5.1.1 In addition to this Section, the control engineering systems are to comply with *Pt 6, Ch 1 Control Engineering Systems*.

5.1.2 For water jets used as the only means of propulsion and steering, a standby or alternative power source for the actuating device that controls the angular position and/or the reversing angle is to be provided. Automatic start of the standby pump supplying hydraulic power for steering and reversing is to be provided.

5.1.3 Means are to be provided at each control station to stop each water jet.

5.2 Monitoring and alarms

5.2.1 In addition to the requirements of *Pt 5, Ch 19 Steering Arrangements*, alarms and monitoring requirements are indicated in *Pt 5, Ch 16, 5.2 Monitoring and alarms 5.2.2 to Pt 5, Ch 16, 5.2 Monitoring and alarms 5.2.4 and Table 16.5.1 Alarms*.

Table 16.5.1 Alarms

Item	Alarm	Note
Hydraulic system pressure	Low	—
Hydraulic oil supply tank level	Low	—
Hydraulic oil temperature	High	Where an oil cooler is fitted
Lubricating oil temperature	High	—
Lubricating oil pressure	Low	In forced lubrication systems
Lubricating oil tank level	Low	Where a tank is provided
Ratio of jet rpm/vessel speed	High	Only if installed power per jet >4 MW
Control system failure	Fault	Includes follow-up failure of steering or reversing system
Control system power supply	Failure	—

5.2.2 An indication of the angular position of the nozzle is to be provided at each station from which it is possible to control the direction of thrust from the units.

5.2.3 An indication of both the required and actual reversing bucket position is to be provided at each station from which it is possible to control the reversal of thrust.

5.2.4 All alarms associated with water jet unit faults are to be indicated individually at the control stations and in accordance with the alarm system specified by *Pt 6, Ch 1 Control Engineering Systems*.

■ Section 6 Electrical systems

6.1 Installation and distribution arrangements

6.1.1 The electrical installation is to comply with the relevant sections of *Pt 6, Ch 2 Electrical Engineering*.

6.1.2 Water jet auxiliaries and controls are to be served by individual circuits. Services that are duplicated are to be separated throughout their length as widely as practicable and without the use of common feeders, transformers, converters, protective devices or control circuits.

■ Section 7 Inspection, testing and fitting of water jets

7.1 General

7.1.1 The finished impeller is to be statically balanced on completion of the manufacturing process and meet the requirements of ISO 1940 or an alternative standard acceptable to LR. In the case where the blade tip speed is greater than 60 m/s, dynamic balancing is required unless otherwise agreed by the manufacturer and LR.

7.1.2 The following tests, markings and inspections are to be carried out in the presence of the Surveyor:

- (a) The balancing of the impeller or the blades.
- (b) Non-destructive examination of the impeller blades and the principal component parts of the propulsion system; see *Ch 4, 8 Stainless steel castings* for austenitic stainless steels and *Ch 8, 3 Aluminium alloy castings* for aluminium alloys of the Rules for Materials.
- (c) The quality of the fit of the impeller boss on the shaft taper.
- (d) The fitting of the impeller to the shaft and its subsequent functional testing.
- (e) The finished surfaces of the impeller boss, conical bores, fillets, cones and blade surfaces are to be shown to conform to the tolerances specified on the impeller drawing.

7.1.3 Bolts and nuts in critical locations, as specified in the FMEA and where indicated by the manufacturer or Shipbuilder and agreed by LR, are to be equipped with adequate securing arrangements to the satisfaction of the LR Surveyor.

7.2 Shop tests and installation of water jet systems

7.2.1 The completed water jet unit is to undergo a tightness test in which an internal hydrostatic pressure of 1,5 bar above the maximum working pressure of the unit is to be applied.

7.2.2 In cases where the impeller is fitted to the shaft using an interference fit, the bedding of the impeller with the shaft is to be demonstrated in the shop to the satisfaction of the LR Surveyor. Sufficient time is to be allowed for the temperature of the components to equalise before bedding. A contact marking between the bore of the impeller boss and the shaft surface of better than 80 per cent is to be demonstrated when the contact marking ink is spread thinly on the surface of the shaft. Alternative means for demonstrating the bedding of the impeller will be considered.

7.2.3 Means are to be provided to indicate the relative axial position of the impeller boss on the shaft. Permanent reference marks are to be made on the impeller boss, shaft and any nut to indicate angular and axial positioning of the impeller. Care is to be taken in marking the inboard end of the shaft taper to minimise stress-raising effects.

7.2.4 A copy of the fitting curve relative to temperature and means for determining any subsequent movement are to be placed on board.

7.2.5 The impeller running clearances are to be checked following the installation of the unit in the ship.

7.2.6 The thrust bearing clearances in the water jet system are to be verified against the required design values. This is to be done following the installation of the unit in the ship.

7.2.7 The piping systems are to be adequately flushed in accordance with the manufacturer's recommendations and the final levels of contamination recorded. Similarly, pressure testing of the piping systems is to comply with *Pt 5, Ch 12 Piping Design Requirements*.

7.3 Sea trial requirement

7.3.1 The following requirements are to be complied with:

- *Pt 5, Ch 1, 5.2 Sea trials* for sea trials.
- *Pt 5, Ch 19, 7.2 Trials* for steering trials.

In addition, the general design capability specified in *Pt 5, Ch 16, 3.1 General 3.1.1* is to be demonstrated to the Surveyor's satisfaction.

7.3.2 The control systems relating to the correct functioning of the water jet are to be the subject of harbour and then sea trials. Demonstration of the requirements of *Pt 6, Ch 1 Control Engineering Systems* is required and the design combinations of control functions are to be undertaken during the trials programme.

7.3.3 On sea trials and under free running conditions the relationship between ship speed and impeller rotational speed is to be verified against the water jet's design basis.

7.3.4 Any trials and testing identified from the FMEA report, see *Pt 5, Ch 16, 2.4 Failure Mode and Effects Analysis (FMEA) 2.4.4*, are to be carried out.

■ Section 8 Installation, maintenance and replacement

8.1 General

8.1.1 All water jet system propulsion units are to be provided with a copy of the manufacturer's installation and maintenance manual that is pertinent to the actual equipment. See *Pt 5, Ch 16, 2.3 Calculations and information 2.3.24*.

8.1.2 The manual required by *Pt 5, Ch 16, 8.1 General 8.1.1* is to be placed on board and is to contain the following information:

- (a) Description of the water jet propulsion system with details of function and design operating limits. This is also to include details of support systems such as lubrication, cooling and condition monitoring arrangements.
- (b) Identification of all components together with details of any that have a defined maximum operating life.
- (c) Instructions for installation of the system on board ship with details of any required specialised equipment.
- (d) Instructions for commissioning at initial installation and following maintenance.
- (e) Maintenance and service instructions to include inspection/ renewal of bearings and sealing arrangements. This is also to include component fitting procedures, clearance measurements and lubricating oil treatment where applicable.
- (f) Actions required in the event of fault/failure conditions being detected.
- (g) Precautions to be taken by personnel working during installation and maintenance.

Requirements for Fusion Welding of Pressure Vessels and Piping

Part 5, Chapter 17

Section 1

Section

- 1 **General**
- 2 **Manufacture and workmanship of fusion welded pressure vessels**
- 3 **Repairs to welds on fusion welded pressure vessels**
- 4 **Post-weld heat treatment of pressure vessels**
- 5 **Welded pressure pipes**
- 6 **Non-Destructive Examination**

■ Section 1 General

1.1 Scope

1.1.1 The requirements of this Chapter apply to the welding of pressure vessels and process equipment, heating and steam raising boilers and pressure pipes. The allocation of Class is determined from the design criteria referenced in Chapters *Pt 5, Ch 10 Steam Raising Plant and Associated Pressure Vessels, Pt 5, Ch 11 Other Pressure Vessels* and *Pt 5, Ch 12 Piping Design Requirements*.

1.1.2 Fusion welded pressure vessels will be accepted only if manufactured by firms equipped and competent to undertake the quality of welding required for the Class of vessel proposed. For Class 1, 2/1 and 2/2 pressure vessels, the manufacturer's works are to be approved in accordance with the requirements specified in *Materials and Qualification Procedures for Ships, Book A Procedure MQPS 0-4*.

1.1.3 For pressure vessels which only have circumferential seams, see *Pt 5, Ch 10, 1.5 Classification of fusion welded pressure vessels 1.5.4* and *Pt 5, Ch 11, 1.5 Classification of fusion welded pressure vessels 1.5.5*

1.2 General requirements for welding plant and welding quality

1.2.1 In the first instance, and before work is commenced, the Surveyors are to be satisfied that the required quality of welding is attainable with the proposed welding plant, equipment and procedures in accordance with the guidelines specified in *Materials and Qualification Procedures for Ships Book A, Procedure 0-4*.

1.2.2 All welding is to be in accordance with the requirements specified in *Ch 13 Requirements for Welded Construction of the Rules for the Manufacture, Testing and Certification of Materials* (hereinafter referred to as the Rules for Materials).

1.3 Manufacture and workmanship of fusion welded pressure vessels

1.3.1 Pressure vessels are to be constructed and examined in accordance with the requirements specified in *Ch 13 Requirements for Welded Construction* of the Rules for Materials, unless more stringent requirements are specified.

■ Section 2 Manufacture and workmanship of fusion welded pressure vessels

2.1 General requirements

2.1.1 Prior to commencing construction, the design of the vessel is to be approved where required by *Pt 5, Ch 10, 1.6 Plans* and *Pt 5, Ch 11, 1.6 Plans*.

2.1.2 Pressure vessels will be accepted only if manufactured by firms that have been assessed and approved in accordance with MQPS 0-4.

Requirements for Fusion Welding of Pressure Vessels and Piping Part 5, Chapter 17

Section 2

2.2 Materials of construction

2.2.1 Where the construction requires post weld heat treatment, consideration should be given to certifying the material after subjecting the test pieces to a simulated heat treatment.

2.3 Tolerances for cylindrical shells

2.3.1 Measurements are to be made to the surface of the parent plate and not to a weld, fitting or other raised part.

2.3.2 In assessing the out-of-roundness of pressure vessels, the difference between the maximum and minimum internal diameters measured at one cross-section is not to exceed the amount given in *Table 17.2.1 Tolerances for cylindrical shells*.

Table 17.2.1 Tolerances for cylindrical shells

Nominal internal diameter of vessel in mm	Difference between maximum and minimum diameters	Maximum departure from designed form
≤ 300	1,0 per cent of internal diameter	1,2 mm
> 300 ≤ 460		1,6 mm
> 460 ≤ 600		2,4 mm
> 600 ≤ 900		3,2 mm
> 900 ≤ 1220		4,0 mm
> 1220 ≤ 1520		4,8 mm
> 1520 ≤ 1900		5,6 mm
> 1900 ≤ 2300	19 mm	6,4 mm
> 2300 ≤ 2670		7,2 mm
> 2670 ≤ 3950		8,0 mm
> 3950 ≤ 4650	19 mm	0,2 per cent of internal diameter
> 4650	0,4 per cent of internal diameter	

2.3.3 The profile measured on the inside or outside of the shell, by means of a gauge of the designed form of the shell, and having a chord length equal to one-quarter of the internal diameter of the vessel, is not to depart from the designed form by more than the amount given in *Table 17.2.1 Tolerances for cylindrical shells*. This amount corresponds to *x* in *Figure 17.2.1 Tolerances for cylindrical shells*.

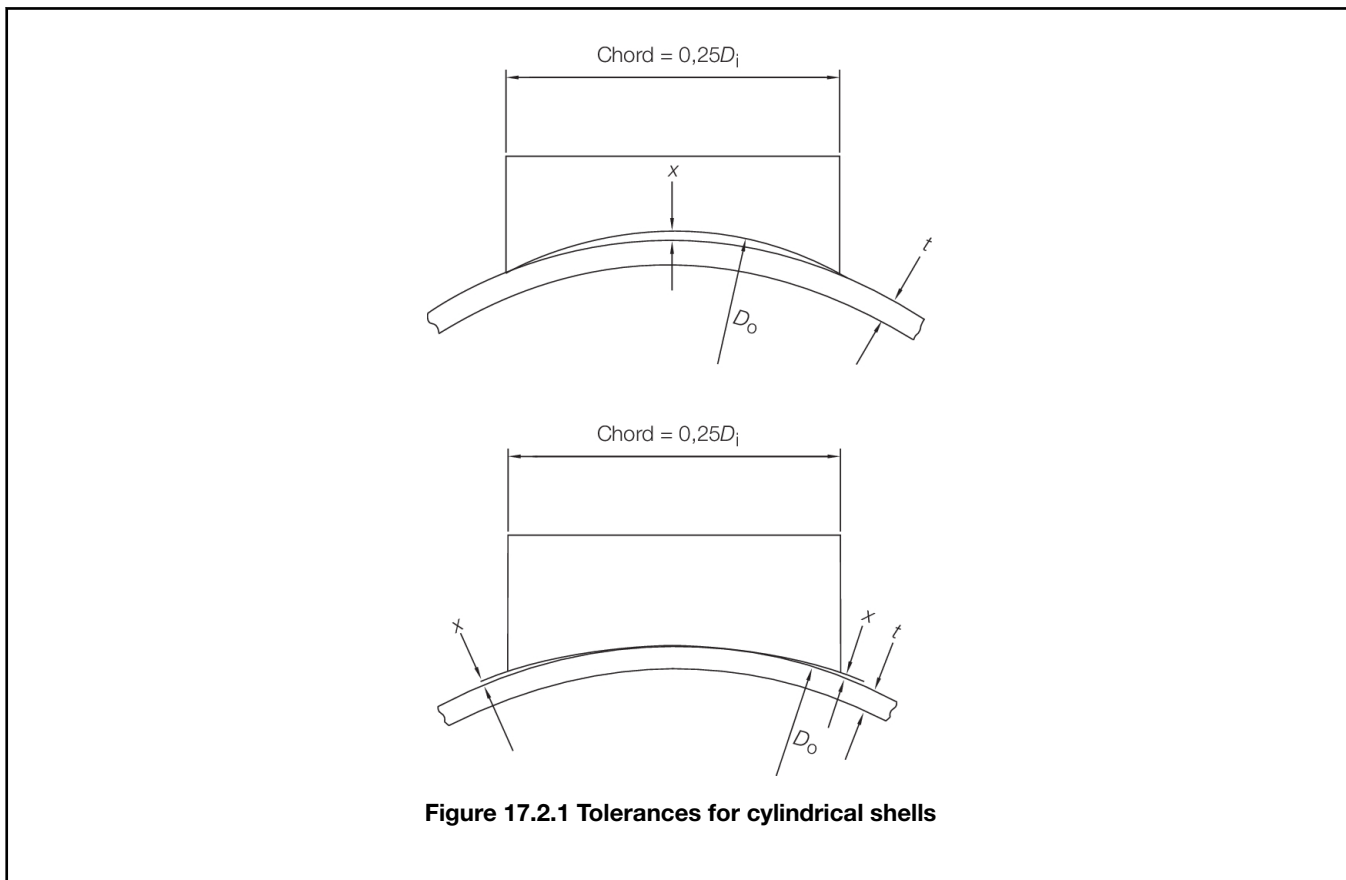

Figure 17.2.1 Tolerances for cylindrical shells

2.3.4 Shell sections are to be measured for out-of-roundness, either when laid flat on their sides or when set up on end. When the shell sections are checked while lying on their sides, each measurement for diameter is to be repeated after turning the shell through 90° about its longitudinal axis. The two measurements for each diameter are to be averaged, and the amount of out-of-roundness calculated from the average values so determined.

2.3.5 Where there is any local departure from circularity due to the presence of flats or peaks at welded seams, the departure from designed form shall not exceed that of *Table 17.2.1 Tolerances for cylindrical shells*.

2.3.6 The external circumference of the completed shell is not to depart from the calculated circumference (based upon nominal inside diameter and the actual plate thickness) by more than the amounts given in *Table 17.2.2 Circumferential tolerances*

Table 17.2.2 Circumferential tolerances

Outside diameter (nominal inside diameter plus twice actual plate thickness), in mm	Circumferential tolerance
300 to 600 inclusive	±5 mm
Greater than 600	±0,25 per cent

■ **Section 3**
Repairs to welds on fusion welded pressure vessels

3.1 General

3.1.1 Repairs to welds on fusion welded pressure vessels are to be in accordance with the requirements of Chapter 13 of the Rules for Materials.

Requirements for Fusion Welding of Pressure Vessels and Piping

Part 5, Chapter 17

Section 4

■ Section 4

Post-weld heat treatment of pressure vessels

4.1 General

4.1.1 Post-weld heat treatment of fusion welded pressure vessels are to be in accordance with the requirements of *Ch 13 Requirements for Welded Construction* of the Rules for Materials.

■ Section 5

Welded pressure pipes

5.1 General

5.1.1 Fabrication of pipework is to be carried out in accordance with the requirements of *Ch 13, 5 Specific requirements for pressure pipework* of the Rules for Materials.

5.2 Welding workmanship

5.2.1 Preheating is to be effected by a method which ensures uniformity of temperature at the joint. The method of heating and the means adopted for temperature control are to be to the satisfaction of the Surveyors.

5.2.2 All welding is to be performed in accordance with the approved welding procedures in this Section by welders who are qualified for the materials, joint types and welding processes employed.

5.2.3 Welding without filler metal is generally not permitted for welding of duplex stainless steel materials.

5.2.4 All welds in high pressure and high temperature pipelines are to have a smooth surface finish and even contour; if necessary, they are to be made smooth by grinding.

5.2.5 Check tests of the quality of the welding are to be carried out periodically at the discretion of the Surveyors.

■ Section 6

Non-Destructive Examination

6.1 General

6.1.1 Non-Destructive Examination (NDE) of pressure vessels and piping is to be performed in accordance with the requirements of *Ch 13, 4 Specific requirements for fusion welded pressure vessels* and *Ch 13, 5 Specific requirements for pressure pipework* of the Rules for Materials.

Section

- 1 **General requirements**
 - 2 **Machinery arrangements**
 - 3 **Control arrangements**
-

■ **Section 1**
General requirements

1.1 General

- 1.1.1 This Chapter applies to both cargo ships and passenger ships and is in addition to other relevant Chapters of the Rules.
- 1.1.2 The Rules contained in this Chapter cover machinery arrangements and control systems necessary for operating essential machinery from a (centralised) control station on the bridge under normal seagoing and manoeuvring conditions, but do not signify that the machinery space may be operated unattended.
- 1.1.3 In general, ships complying with the requirements of this Chapter will be eligible for the machinery class notation **IP**, see *Pt 1, Ch 2, 2.4 Class notations (machinery)*.
- 1.1.4 The details of control systems will vary with the type of machinery being controlled, and special consideration will be given to each case.

1.2 Plans

- 1.2.1 **Control systems.** Where control systems are applied to essential machinery or equipment the following plans are to be submitted in triplicate:
- Details of operating medium, i.e. pneumatic, hydraulic or electric including standby sources of power.
 - Description of operation with explanatory diagrams.
 - Line diagrams of control circuits.
 - List of monitored points.
 - List of control points.
 - List of alarm points.
 - Test schedule including test facilities provided.
- 1.2.2 Plans for the control systems of the following machinery are to be submitted:
- Main propelling machinery, including all auxiliaries essential for propulsion.
 - Controllable pitch propellers.
 - Electric generating plant.
 - Evaporating and distilling systems for use with main steam machinery.
 - Steam raising plant for essential services.
- 1.2.3 **Alarm systems.** Details of the overall alarm system linking the machinery space control station with the bridge control station are to be submitted.
- 1.2.4 **Control stations.** Details of bridge and machinery space control stations are to be submitted, e.g. control panels and consoles.
- 1.2.5 **Machinery configurations.** Plans showing the general arrangement of the machinery space, together with the layout and configuration of the main propulsion and essential machinery, are to be submitted.

■ Section 2**Machinery arrangements****2.1 Main propulsion machinery**

2.1.1 The main propulsion machinery may be oil engines, turbines or electric motors but the configuration of the propulsion system and its relationship with other essential equipment is to comply with the remaining requirements of this Section.

2.1.2 The main propulsion machinery is to drive one of the generators required by *Pt 5, Ch 18, 2.2 Supply of electric power and essential services 2.2.2*. This generator is to be capable of supplying the essential electrical load under all normal sea-going and manoeuvring conditions.

2.1.3 Standby machinery is to be provided capable of being readily connected to the main propulsion system so as to provide emergency propulsion. This standby machinery is to be capable of connection so as to provide an alternative drive to the generator required in *Pt 5, Ch 18, 2.1 Main propulsion machinery 2.1.2*. It need not provide power to both systems simultaneously, see also *Pt 5, Ch 18, 2.2 Supply of electric power and essential services 2.2.2*.

2.2 Supply of electric power and essential services

2.2.1 Continuity of electrical power supply and essential services are to be ensured under all normal sea-going and manoeuvring conditions without manual intervention in the machinery space. Methods by which this may be achieved include automatic start-up of generating sets and essential pumps or manual start-up of these services from the bridge.

2.2.2 Generating sets and converting sets are to be sufficient to ensure the operation of services essential for the propulsion and safety of the ship even when one generating set or converting set is out of service.

2.3 Controllable pitch propellers

2.3.1 For propulsion systems with controllable pitch propellers a standby or alternative power source for the actuating medium for controlling the pitch of the propeller blades is to be provided.

■ Section 3**Control arrangements****3.1 Bridge control**

3.1.1 Means are to be provided to ensure satisfactory control of propulsion from the bridge in both the ahead and astern directions when operating on either the main or standby engine(s).

3.1.2 Instrumentation to indicate the following is to be fitted on the bridge and at any other station from which the propulsion machinery may be controlled:

- (a) Propeller speed.
- (b) Direction of rotation of the propeller for a fixed pitch propeller.
- (c) Pitch position for a controllable pitch propeller.
- (d) Direction and magnitude of thrust.
- (e) Clutch position, where applicable.

3.1.3 An alarm is to operate in the event of a failure of the power supply to the bridge control system.

3.1.4 Emergency Stop Functions, independent of the bridge control system, are to be provided on the bridge to enable the watchkeeping officer to stop the main propulsion machinery in an emergency.

3.2 Alarm system

3.2.1 An alarm system is to be provided to indicate faults in essential machinery and control systems in accordance with this Chapter.

- 3.2.2 Machinery faults are to be indicated at the control stations on the bridge and in the machinery space.
- 3.2.3 In the event of a machinery fault occurring, the alarm system is to be such that the watchkeeping officer on the bridge is made aware of the following.
- (a) A machinery fault has occurred.
 - (b) The machinery fault is being attended to, and
 - (c) The machinery fault has been rectified. (Alternative means of communication between the bridge control station and the machinery control station may be used for this function.)
- 3.2.4 The alarm system should be designed with self-monitoring properties. As far as practicable, any fault in the alarm system should cause it to fail to the alarm condition.
- 3.2.5 The alarm system should be capable of being tested during normal machinery operation.
- 3.2.6 Failure of the power supply to the alarm system is to be indicated as a separate fault alarm.
- 3.2.7 Alarm indication is to be both audible and visual. If arrangements are made to silence audible alarms they are not to extinguish visual alarms.
- 3.2.8 The acceptance of an alarm on the bridge is not to silence the audible alarm in the machinery space.
- 3.2.9 Machinery alarms should be distinguishable from other audible alarms, e.g. fire, carbon dioxide.
- 3.2.10 Acknowledgement of visual alarms is to be clearly shown.
- 3.2.11 If the audible alarm has been silenced and a second fault occurs before the first has been rectified, the audible alarm is again to operate. To assist in the detection of transient faults which are subsequently self-correcting, fleeting alarms should lock-in until accepted.

3.3 Communication

- 3.3.1 Two means of communication are to be provided between the bridge and the control station in the machinery space. One of these means may be the bridge control system; the other is to be independent of the main electrical power supply.
- 3.3.2 The bridge, machinery space control station and any other control position from which the propulsion machinery can be controlled are to be fitted with means to indicate which station is in command.
- 3.3.3 Change-over between control stations is to be possible under all normal sea-going and manoeuvring conditions without affecting the speed or direction of propulsion. This change-over may be effected only with the acceptance of the station taking control.

3.4 Engine starting safeguards

- 3.4.1 Where it is possible to start a main propulsion or auxiliary oil engine from the bridge, an indication that sufficient starting air pressure is available is to be provided on the bridge.
- 3.4.2 The number of automatic consecutive attempts which fail to produce a start is to be limited to safeguard sufficient starting air pressure, or, in the case of electric starting, a sufficient charge level in the batteries.
- 3.4.3 An alarm is to be provided for low starting air pressure, set at a limit which will still permit engine starting operations.
- 3.4.4 Where propulsion or auxiliary engines are started from the bridge, interlocks are to be provided to prevent starting of the engine under conditions which could hazard the machinery. These are to include 'turning gear engaged', 'low lubricating oil pressure' and 'shaft brake engaged'.

3.5 Operational safeguards

- 3.5.1 Means are to be provided to prevent the machinery and shafting being subjected to excessive torque or other detrimental mechanical and thermal overloads.
- 3.5.2 Prolonged running in a restricted speed range is to be prevented automatically or, alternatively, an indication of restricted speed ranges is to be provided at each control station.
- 3.5.3 For ships propelled by steam turbines the risk of thermal distortion of the turbines is to be prevented by automatic steam spinning when the shaft is stopped in the manoeuvring mode. An audible and visual alarm is to operate on the bridge and in the machinery space when the shaft has been stopped for two minutes.

3.5.4 In the case of lubricating oil systems for main propulsion and standby engine(s), the engine(s) is to be stopped automatically on failure of the lubricating oil supply. The circuit and sensor employed for this automatic shut-down are to be additional to the alarm circuit and sensor required by *Pt 5, Ch 14, 8 Lubricating oil systems*. Where means are provided to override the automatic shut-down required by this paragraph, the arrangements are to be such as to preclude inadvertent operation. Visual indication of operation of the override is to be fitted.

3.5.5 In the case of oil engines, oil mist monitoring is to be provided for crankcase protection where arrangements are fitted to override the automatic stop for failure of the lubricating oil supply.

3.5.6 Boilers with automatic controls which under normal operating conditions do not require any manual intervention by the operators are to be provided with safety arrangements which automatically shut-off the fuel oil to all the burners in the event of either low water level or combustion air failure. Fuel oil is to be shut-off automatically to any burner in the event of flame failure.

3.5.7 Arrangements are to be provided to automatically stop propulsion gas turbines for the following fault conditions:

- (a) Overspeed, see *Pt 5, Ch 4, 4 Design and construction*.
- (b) High exhaust temperature, see *Pt 5, Ch 4, 3 Materials*.
- (c) Flame failure, or
- (d) Excessive vibration.

3.5.8 Where standby pumps are arranged to start automatically in the event of low discharge pressure from the working pump an alarm is to be given to indicate when the standby pump has started.

3.6 Automatic control of essential services

3.6.1 All control systems for essential services are to be stable throughout the operating range of the main propulsion machinery.

3.6.2 The temperature of the following is to be automatically controlled within normal operating limits:

Oil engines:

- (a) Lubricating oil to the main engine and/or auxiliary engines.
- (b) Fuel oil – temperature or viscosity.
- (c) Piston coolant, where applicable.
- (d) Cylinder coolant main and auxiliary engines, where applicable.
- (e) Fuel valve coolant, where applicable.

Steam plant:

- (a) Lubricating oil to main engine and/or auxiliary engines.
- (b) Fuel oil to burners – temperature or viscosity.
- (c) Superheated steam.
- (d) External de-superheated steam.

Gas turbines:

- (a) Lubricating oil to main engine and auxiliary engines.
- (b) Fuel oil – temperature or viscosity.
- (c) Exhaust gas.

3.6.3 The pressure of the following is to be automatically controlled within normal operating limits:

Steam plant:

- (a) Superheated steam.
- (b) Fuel oil.
- (c) External de-superheated steam system(s).
- (d) Gland steam.
- (e) Reduced steam ranges.

3.6.4 The level of the following is to be automatically controlled within normal operating limits:

Steam plant:

- (a) Boiler drum level.

- (b) De-aerator level.
- (c) Condenser level.

3.6.5 Boilers essential for the propulsion of the vessel are to be provided with an automatic combustion control system.

3.7 Local control

3.7.1 The arrangements are to be such that essential machinery can be operated with the system of bridge control or any automatic controls out of action. Alternatively, the control systems should have sufficient redundancy so that failure of the control equipment in use does not render essential machinery inoperative.

Section

-
- 1 **General**
 - 2 **Performance**
 - 3 **Construction and design**
 - 4 **Steering control systems**
 - 5 **Electric power circuits, electric control circuits, monitoring and alarms**
 - 6 **Emergency power**
 - 7 **Testing and trials**
 - 8 **Additional requirements**
 - 9 **'Guidelines' for the acceptance of non-duplicated rudder actuators for tankers, chemical tankers and gas carriers of 10 000 tons gross and upwards but of less than 100 000 tons deadweight**
-

■ *Section 1*
General

1.1 Application

- 1.1.1 The requirements of this Chapter apply to the design and construction of steering arrangements.
- 1.1.2 Whilst the requirements satisfy the relevant regulations of the *SOLAS - International Convention for the Safety of Life at Sea* as amended, and the IMO Protocol of 1978, attention should be given to any relevant statutory requirements of the National Authority of the country in which the ship is to be registered.
- 1.1.3 Consideration will be given to other cases, or to arrangements which are equivalent to those required by the Rules.

1.2 Definitions

- 1.2.1 **Steering gear control system** means the equipment by which orders are transmitted from the navigating bridge to the steering gear power units. Steering gear control systems comprise transmitters, receivers, hydraulic control pumps and their associated motors, motor controllers, piping and cables.
- 1.2.2 **Main steering gear** means the machinery, rudder actuator(s), the steering gear power units, if any, and ancillary equipment and the means of applying torque to the rudder stock (e.g. tiller or quadrant) necessary for effecting movement of the rudder for the purpose of steering the ship under normal service conditions.
- 1.2.3 **Steering gear power unit** means:
 - (a) in the case of electric steering gear, an electric motor and its associated electrical equipment;
 - (b) in the case of electrohydraulic steering gear, an electric motor and its associated electrical equipment and connected pump;
 - (c) in the case of other hydraulic steering gear, a driving engine and connected pump.
- 1.2.4 **Auxiliary steering gear** means the equipment other than any part of the main steering gear necessary to steer the ship in the event of failure of the main steering gear but not including the tiller, quadrant or components serving the same purpose.
- 1.2.5 **Power actuating system** means the hydraulic equipment provided for supplying power to turn the rudder stock, comprising a steering gear power unit or units, together with the associated pipes and fittings, and a rudder actuator. The power actuating systems may share common mechanical components, i.e. tiller quadrant and rudder stock, or components serving the same purpose.
- 1.2.6 **Maximum ahead service speed** means the maximum service speed which the ship is designed to maintain, at the summer load waterline at maximum propeller RPM and corresponding engine MCR.

1.2.7 **Rudder actuator** means the components which convert directly hydraulic pressure into mechanical action to move the rudder.

1.2.8 **Maximum working pressure** means the maximum expected pressure in the system when the steering gear is operated to comply with *Pt 5, Ch 19, 2.1 General 2.1.2*.

1.2.9 **Steering arrangements** means the complete system of components for providing ship directional control.

1.2.10 **Directional control system** means the equipment used to effect changes in ship direction e.g. the rudder, podded propulsion unit, azimuth thrusters or water jet nozzle. Note that for podded propulsion systems, azimuth thrusters, water jet systems, or other similar systems for effecting changes in ship direction, it is to be assumed that the units must provide thrust in addition to rotation and hence the directional control system must include the propulsion system.

1.3 General

1.3.1 The steering gear is to be secured to the seating by fitted bolts, and suitable chocking arrangements are to be provided. The seating is to be of substantial construction.

1.3.2 The steering gear compartment is to be:

- (a) readily accessible and, as far as practicable, separated from machinery spaces; and
- (b) provided with suitable arrangements to ensure working access to steering gear machinery and controls. These arrangements are to include handrails and gratings or other non-slip surfaces to ensure suitable working conditions in the event of hydraulic fluid leakage.

1.4 Plans

1.4.1 Before starting construction, the steering gear machinery plans, specifications and calculations are to be submitted. The plans are to give:

- (a) Details of scantlings and materials of all load bearing and torque transmitting components and hydraulic pressure retaining parts together with proposed rated torque and all relief valve settings.
- (b) Schematic of the hydraulic system(s), together with pipe material, relief valves and working pressures.
- (c) Details of control and electrical aspects.

1.5 Materials

1.5.1 All components used in steering arrangements for ship directional control are to be of sound reliable construction to the Surveyor's satisfaction.

1.5.2 All components transmitting mechanical forces to the rudder stock are to be tested according to the requirements of the *Rules for the Manufacture, Testing and Certification of Materials* (hereinafter referred to as the *Rules for the Manufacture, Testing and Certification of Materials, July 2015*).

1.5.3 Ram cylinders; pressure housings of rotary vane type actuators, hydraulic power piping, valves, flanges and fittings; and all steering gear components transmitting mechanical forces to the rudder stock (such as tillers, quadrants, or similar components) are to be of steel or other approved ductile material, duly tested in accordance with the requirements of the *Rules for the Manufacture, Testing and Certification of Materials, July 2015*. In general, such material is to have an elongation of not less than 12 per cent nor a tensile strength in excess of 650 N/mm². Special consideration will be given to the acceptance of grey cast iron for valve bodies and redundant parts with low stress levels.

1.5.4 Where appropriate, consideration will be given to the acceptance of non-ferrous material.

1.6 Rudder, rudder stock, tiller and quadrant

1.6.1 For the requirements of rudder and rudder stock, see *Pt 3, Ch 13, 2 Rudders*.

1.6.2 For the requirements of tillers and quadrants including the tiller to stock connection, see *Table 19.1.1 Connection of tiller to stock*.

1.6.3 In bow rudders having a vertical locking pin operated from the deck above, positive means are to be provided to ensure that the pin can be lowered only when the rudder is exactly central. In addition, an indicator is to be fitted at the deck to show when the rudder is exactly central.

1.6.4 The factor of safety against slippage, *S* (i.e. for torque transmission by friction) is generally based on

$$S = \frac{\text{the torque transmissible by friction}}{M}$$

where M is the maximum torque at the relief valve pressure which is generally equal to the design torque as specified by the steering gear manufacturer.

1.6.5 For conical sections, S is based on the following equation:

$$S = \frac{\mu A \sigma_r}{\sqrt{(W + A \sigma_r \theta)^2 + Q^2}}$$

where

A = interfacial surface area, in mm^2

W = weight of rudder and stock, if applicable, when tending to separate the fit, in N

Q = shear force = $\frac{2M}{d_m}$ in N

where

d_m in mm is the mean contact diameter of tiller/stock interface and M in Nmm is defined in *Pt 5, Ch 19, 1.6 Rudder, rudder stock, tiller and quadrant 1.6.4*

θ = cone taper half angle in radians (e.g. for cone taper 1:10, $\theta = 0,05$)

μ = coefficient of friction

σ_r = radial interfacial pressure or grip stress, in N/mm^2 .

Table 19.1.1 Connection of tiller to stock

Item	Requirements
(1) Dry fit - tiller to stock, see also <i>Pt 5, Ch 19, 1.6 Rudder, rudder stock, tiller and quadrant 1.6.4</i> and <i>Pt 5, Ch 19, 1.6 Rudder, rudder stock, tiller and quadrant 1.6.5</i>	(a) or keyed connection, factor of safety against slippage, $S = 1,0$ The maximum stress in the fillet radius of the tiller keyway should not exceed the yield stress For conical sections, the cone taper should be $\leq 1:10$ (b) For keyless connection, factor of safety against slippage, $S = 2,0$ The maximum equivalent von Mises stress should not exceed the yield stress For conical sections, the cone taper should be $\leq 1:15$ (c) Coefficient of friction (maximum) = 0,17 (d) Grip stress not to be less than 20 N/mm^2
(2) Hydraulic fit - tiller to stock, see also <i>Pt 5, Ch 19, 1.6 Rudder, rudder stock, tiller and quadrant 1.6.4</i> and <i>Pt 5, Ch 19, 1.6 Rudder, rudder stock, tiller and quadrant 1.6.5</i>	(a) For keyed connection, factor of safety against slippage, $S = 1,0$ The maximum stress in the fillet radius of the tiller keyway should not exceed the yield stress For conical sections, the cone taper should be $\leq 1:10$ (b) For keyless connection, factor of safety against slippage, $S = 2,0$ The maximum equivalent von Mises stress should not exceed the yield stress For conical sections, the cone taper should be $\leq 1:15$ (c) Coefficient of friction (maximum) = 0,14 (d) Grip stress not to be less than 20 N/mm^2
(3) Ring locking assemblies fit - tiller to stock, see also <i>Pt 5, Ch 19, 1.6 Rudder, rudder stock, tiller and quadrant 1.6.3</i>	(a) Factor of safety against slippage, $S = 2,0$ The maximum equivalent von Mises stress should not exceed the yield stress (b) Coefficient of friction = 0,12 (c) Grip stress not to be less than 20 N/mm^2

Steering Arrangements

Part 5, Chapter 19

Section 1

<p>(4) Bolted tiller and quadrant (this arrangement could be accepted provided the proposed rudder stock diameter in way of tiller does not exceed 350 mm diameter), see symbols</p>	<p>Shim to be fitted between two halves before machining to take rudder stock, then removed prior to fitting</p> <p>Minimum thickness of shim, For 4 connecting bolts: $t_s = 0,0014 \delta_t$ mm For 6 connecting bolts: $t_s = 0,0012 \delta_t$ mm</p> <p>Key(s) to be fitted</p> <p>Diameter of bolts, $\delta_{tb} = \frac{0,60 \delta_{su}}{\sqrt{n_{tb}}} \text{ mm}$</p> <p>A predetermined setting-up load equivalent to a stress of approximately 0,7 of the yield strength of the bolt material should be applied to each bolt on assembly. A lower stress may be accepted provided that two keys, complying with item (5), are fitted.</p> <p>Distance from centre of stock to centre of bolts should generally be equal to $\delta_t \left(1,0 + \frac{0,30}{\sqrt{n_{tb}}} \right) \text{ mm}$</p> <p>Thickness of flange on each half of the bolted tiller $\geq \frac{0,66 \delta_t}{\sqrt{n_{tb}}} \text{ mm}$</p>
<p>(5) Key/keyway, see symbols</p>	<p>Effective sectional area of key in shear $\geq 0,25 \delta_t^2 \text{ mm}^2$</p> <p>Key thickness $\geq 0,17 \delta_t$ mm</p> <p>Keyway is to extend over full depth of tiller and is to have a rounded end. Keyway root fillets are to be provided with suitable radii to avoid high local stress</p>
<p>(6) Section modulus - tiller arm (at any point within its length about vertical axis), see symbols</p>	<p>To be not less than the greater of:</p> $Z_{TA} = \frac{0,15 \delta_t^3 (b_T - b_s)}{1000 b_T} \text{ cm}^3$ $Z_{TA} = \frac{0,06 \delta_t^3 (b_T - 0,9 \delta_t)}{1000 b_T} \text{ cm}^3$ <p>If more than one arm fitted, combined modulus is to be not less than the greater of (a) or (b) For solid tillers, the breadth to depth ratio is not to exceed 2</p>
<p>(7) Boss, see symbols</p>	<p>Depth of boss $\geq \delta_t$ Thickness of boss in way of tiller $\geq 0,4 \delta_t$</p>
<p>Symbols</p>	
<p>b_s = distance between the section of the tiller arm under consideration and the centre of the rudder stock, in mm</p> <p>b_T and b_s are to be measured with zero rudder angle</p> <p>b_T = distance from the point of application of the load on the tiller to the centre of the rudder stock, in mm</p> <p>n_{tb} = number of bolts in the connection flanges, but generally not to be taken greater than six</p> <p>t_s = thickness of shim for machining bolted tillers and quadrants, in mm</p> <p>Z_{TA} = section modulus of tiller arm, in cm^3</p>	

δ_t = Rule rudderstock diameter in way of tiller, see Pt 3, Ch 13 Ship Control Systems

δ_{tb} = diameter of bolts securing bolted tillers and quadrants, in mm

■ Section 2 Performance

2.1 General

2.1.1 Unless the main steering arrangements for ship directional control comprise two or more identical power units, in accordance with Pt 5, Ch 19, 2.1 General 2.1.4 or Pt 5, Ch 19, 8.1 For tankers, chemical tankers, or gas carriers of 10 000 tons gross and upwards and every other ship of 70 000 tons gross and upwards 8.1.1, every ship is to be provided with main steering arrangements and auxiliary steering arrangements in accordance with the requirements of the Rules. The main and auxiliary steering arrangements are to be so arranged that the failure of one of them will not render the other one inoperative.

2.1.2 The main steering arrangements for ship directional control are to be:

- Of adequate strength and capable of steering the ship at maximum ahead service speed which shall be demonstrated in accordance with Pt 5, Ch 19, 7.2 Trials;
- Capable of putting the rudder over from 35° on one side to 35° on the other side with the ship at its deepest sea-going draught and running ahead at maximum ahead service speed and under the same conditions, from 35° on either side to 30° on the other side in not more than 28 seconds.
- Operated by power where necessary to meet the requirements of Pt 5, Ch 19, 2.1 General 2.1.2 and in any case when the Rules excluding strengthening for navigation in ice, require a rudder stock over 120 mm diameter in way of the tiller; and
- So designed that they will not be damaged at maximum astern speed; however, this design requirement need not be proved by trials at maximum astern speed and maximum rudder angle.

2.1.3 The auxiliary steering arrangements for ship directional control are to be:

- Of adequate strength and capable of steering the ship at navigable speed and of being brought speedily into action in an emergency;
- Capable of putting the rudder over from 15° on one side to 15° on the other side in not more than 60 seconds with the ship at its deepest sea-going draught and running ahead at one half of the maximum ahead service speed or 7 knots, whichever is the greater; and
- Operated by power where necessary to meet the requirements of Pt 5, Ch 19, 2.1 General 2.1.3 and in any case when the Rules, excluding strengthening for navigation in ice, require a rudder stock over 230 mm diameter in way of the tiller.

2.1.4 Where the main steering arrangements for ship directional control comprise two or more identical power units, auxiliary steering arrangements need not be fitted, provided that:

- In a passenger ship, the main steering arrangements are capable of operating the ship's directional control system as required by Pt 5, Ch 19, 2.1 General 2.1.2 while any one of the power units is out of operation;
- In a cargo ship, the main steering arrangements are capable of operating the ship's directional control system as required by Pt 5, Ch 19, 2.1 General 2.1.2 while operating with all power units;
- The main steering arrangements are arranged so that after a single failure in its piping system or in one of the power units the defect can be isolated so that steering capability can be maintained or speedily regained.

2.1.5 Main and auxiliary steering gear power units are to be:

- Arranged to re-start automatically when power is restored after power failure;
- Capable of being brought into operation from a position on the navigating bridge. In the event of a power failure to any one of the steering gear power units, an audible and visual alarm is to be given on the navigating bridge;
- Arranged so that transfer between units can be readily effected.

2.1.6 Where the steering arrangements are such that more than one power or control system can be simultaneously operated, the risk of hydraulic locking caused by a single failure is to be considered.

- 2.1.7 A means of communication is to be provided between the navigating bridge and the steering gear compartment.
- 2.1.8 Steering gear, other than of the hydraulic type, will be accepted provided the standards are considered equivalent to the requirements of this Section.
- 2.1.9 Manually operated gears are only acceptable when the operation does not require an effort exceeding 16 kg under normal conditions.

2.2 Rudder angle limiters

- 2.2.1 Power-operated steering gears are to be provided with positive arrangements, such as limit switches, for stopping the gear before the rudder stops are reached. These arrangements are to be synchronised with the gear itself and not with the steering gear control.

■ Section 3 Construction and design

3.1 General

- 3.1.1 Rudder actuators other than those covered by *Pt 5, Ch 19, 8.3 For tankers, chemical tankers or gas carriers of 10 000 tons gross and upwards but of less than 100 000 tons deadweight* and the 'Guidelines' are to be designed in accordance with the relevant requirements of *Pt 5, Ch 11 Other Pressure Vessels* for Class I pressure vessels (notwithstanding any exemptions for hydraulic cylinders).
- 3.1.2 Accumulators, if fitted, are to comply with the relevant requirements of *Pt 5, Ch 11 Other Pressure Vessels*.
- 3.1.3 The welding details and welding procedures are to be approved. All welded joints within the pressure boundary of a rudder actuator or connecting parts transmitting mechanical loads are to be full penetration type or of equivalent strength.
- 3.1.4 The construction is to be such as to minimise local concentrations of stress.
- 3.1.5 The design pressure for calculations to determine the scantlings of piping and other steering gear components subjected to internal hydraulic pressure shall be at least 1,25 times the maximum working pressure to be expected under the operational conditions specified in *Pt 5, Ch 19, 2.1 General 2.1.2* taking into account any pressure which may exist in the low pressure side of the system. Fatigue criteria may be applied for the design of piping and components, taking into account pulsating pressures due to dynamic loads, see *Pt 5, Ch 19, 9 'Guidelines' for the acceptance of non-duplicated rudder actuators for tankers, chemical tankers and gas carriers of 10 000 tons gross and upwards but of less than 100 000 tons deadweight*.
- 3.1.6 For the rudder actuator, the permissible primary general membrane stress is not to exceed the lower of the following values:

$$\frac{\sigma_B}{A} \text{ or } \frac{\sigma_y}{B}$$

where

σ_B = specified minimum tensile strength of material at ambient temperature

σ_y = specified minimum yield stress or 0,2 per cent proof stress of the material, at ambient temperature

A and B are given by the following Table:

	Wrought steel	Cast steel	Nodular cast iron
A	3,5	4	5
B	1,7	2	3

3.2 Components

3.2.1 Special consideration is to be given to the suitability of any essential component which is not duplicated. Any such essential component shall, where appropriate, utilise anti-friction bearings such as ball bearings, roller bearings or sleeve bearings which shall be permanently lubricated or provided with lubrication fittings.

3.2.2 All steering gear components transmitting mechanical forces to the rudder stock, which are not protected against overload by structural rudder stops or mechanical buffers, are to have a strength at least equivalent to that of the rudder stock in way of the tiller.

3.2.3 Actuator oil seals between non-moving parts, forming part of the external pressure boundary, are to be of the metal upon metal type or of an equivalent type.

3.2.4 Actuator oil seals between moving parts, forming part of the external pressure boundary, are to be duplicated, so that the failure of one seal does not render the actuator inoperative. Alternative arrangements providing equivalent protection against leakage may be accepted.

3.2.5 Piping, joints, valves, flanges and other fittings are to comply within the requirements of *Pt 5, Ch 12 Piping Design Requirements* for Class I piping systems components. The design pressure is to be in accordance with *Pt 5, Ch 19, 3.1 General 3.1.5*.

3.2.6 Hydraulic power operated steering gear are to be provided with the following :

- (a) Arrangements to maintain the cleanliness of the hydraulic fluid taking into consideration the type and design of the hydraulic system;
- (b) A fixed storage tank having sufficient capacity to recharge at least one power actuating system including the reservoir, where the main steering gear is required to be power operated. The storage tank is to be permanently connected by piping in such a manner that the hydraulic systems can be readily recharged from a position within the steering gear compartment and provided with a contents gauge.

3.3 Valve and relief valve arrangements

3.3.1 For vessels with non-duplicated actuators, isolating valves are to be fitted at the connection of pipes to the actuator, and are to be directly fitted on the actuator.

3.3.2 Arrangements for bleeding air from the hydraulic system are to be provided, where necessary.

3.3.3 Relief valves are to be fitted to any part of the hydraulic system which can be isolated and in which pressure can be generated from the power source or from external forces. The settings of the relief valves is not to exceed the design pressure. The valves are to be of adequate size and so arranged as to avoid an undue rise in pressure above the design pressure.

3.3.4 Relief valves for protecting any part of the hydraulic system which can be isolated, as required by *Pt 5, Ch 19, 3.3 Valve and relief valve arrangements 3.3.3* are to comply with the following:

- (a) The setting pressure is not to be less than 1,25 times the maximum working pressure.
- (b) the minimum discharge capacity of the relief valve(s) is not to be less than 110 per cent of the total capacity of the pumps which can deliver through it (them).

Under such conditions the rise in pressure is not to exceed 10 per cent of the setting pressure. In this regard, due consideration is to be given to extreme foreseen ambient conditions in respect of oil viscosity.

3.4 Flexible hoses

3.4.1 Hose assemblies approved by Lloyd's Register (hereinafter referred to as 'LR') may be installed between two points where flexibility is required but are not to be subjected to torsional deflection (twisting) under normal operating conditions. In general, the hose should be limited to the length necessary to provide for flexibility and for proper operation of machinery, see *also Pt 5, Ch 12, 7 Flexible hoses*.

3.4.2 Hoses should be high pressure hydraulic hoses according to recognised Standards and suitable for the fluids, pressures, temperatures and ambient conditions in question.

3.4.3 Burst pressure of hoses is to be not less than four times the design pressure.

■ Section 4 Steering control systems

4.1 General

4.1.1 Steering gear control is to be provided:

- (a) For the main steering gear, both on the navigating bridge and in the steering gear compartment;
- (b) Where the main steering gear is arranged according to *Pt 5, Ch 19, 2.1 General 2.1.4*, by two independent control systems, both operable from the navigating bridge. This does not require duplication of the steering wheel or steering lever. Where the control system consists of a hydraulic telemotor, a second independent system need not be fitted, except in a tanker, chemical tanker or gas carrier of 10 000 gross tonnage and upwards;
- (c) For the auxiliary steering gear, in the steering gear compartment and, if power operated, it shall also be operable from the navigating bridge and is to be independent of the control system for the main steering gear.
- (d) Where the steering gear is so arranged that more than one control system can be simultaneously operated, the risk of hydraulic locking caused by single failure is to be considered.

4.1.2 Any main and auxiliary steering gear control system operable from the navigating bridge is to comply with the following:

- (a) Means are to be provided in the steering gear compartment for disconnecting any control system operable from the navigating bridge from the steering gear it serves;
- (b) The system is to be capable of being brought into operation from a position on the navigating bridge.

4.1.3 The angular position of the rudder shall:

- (a) If the main steering gear is power operated, be indicated on the navigating bridge. The rudder angle indication is to be independent of the steering gear control system;
- (b) Be recognisable in the steering gear compartment.

4.1.4 Appropriate operating instructions with a block diagram showing the changeover procedures for steering gear control systems and steering gear actuating systems are to be permanently displayed in the wheelhouse and in the steering gear compartment.

4.1.5 Where the system failure alarms for hydraulic lock, see *Table 19.5.1 Alarm requirements*, are provided, appropriate instructions shall be placed on the navigating bridge to shut down the system at fault.

■ Section 5 Electric power circuits, electric control circuits, monitoring and alarms

5.1 Electric power circuits

5.1.1 Short-circuit protection, an overload alarm and, in the case of polyphase circuits, an alarm to indicate single phasing is to be provided for each main and auxiliary motor circuit. Protective devices are to operate at not less than twice the full load current of the motor or circuit protected and are to allow excess current to pass during the normal accelerating period of the motors.

5.1.2 Where steering gear motor circuits are supplied by converters, consideration will be given to arrangements that provide an equivalent level of safety, reliability, availability and indication to those specified in *Pt 5, Ch 19, 5.1 Electric power circuits 5.1.1*, provided that technical justification is submitted.

5.1.3 The alarms required by *Pt 5, Ch 19, 5.1 Electric power circuits 5.1.1* are to be provided on the bridge and in the main machinery space or control room from which the main machinery is normally controlled.

5.1.4 Indicators for running indication of each main and auxiliary motor are to be installed on the navigating bridge and at a suitable main machinery control position.

5.1.5 A low-level alarm is to be provided for each power actuating system hydraulic fluid reservoir to give the earliest practicable indication of hydraulic fluid leakage. Alarms are to be given on the navigation bridge and in the machinery space where they can be readily observed.

5.1.6 Two exclusive circuits are to be provided for each electric or electrohydraulic steering gear arrangement consisting of one or more electric motors.

5.1.7 Each of these circuits is to be fed from the main switchboard. One of these circuits may pass through the emergency switchboard.

5.1.8 One of these circuits may be connected to the motor of an associated auxiliary electric or electrohydraulic power unit.

5.1.9 Each of these circuits is to have adequate capacity to supply all the motors which can be connected to it and which can operate simultaneously.

5.1.10 These circuits are to be separated throughout their length as widely as is practicable.

5.1.11 In ships of less than 1600 gross tonnage, if an auxiliary steering gear is not electrically powered or is powered by an electric motor primarily intended for other services, the main steering gear may be fed by one circuit from the main switchboard. Consideration would be given to other protective arrangements than described in *Pt 5, Ch 19, 5.1 Electric power circuits 5.1.1*, for such a motor primarily intended for other services.

5.2 Electric control circuits

5.2.1 Electric control systems are to be independent and separated as far as is practicable throughout their length.

5.2.2 Each main and auxiliary electric control system which is to be operated from the navigating bridge is to comply with the following:

- (a) It is to be served with electric power by a separate circuit supplied from the associated steering gear power circuit, from a point within the steering gear compartment, or directly from the same section of switchboard busbars, main or emergency, to which the associated steering gear power circuit is connected.
- (b) Each separate circuit is to be provided with short-circuit protection only.

5.3 Monitoring and alarms

5.3.1 Alarms and monitoring requirements are indicated in *Pt 5, Ch 19, 5.3 Monitoring and alarms 5.3.2* and *Table 19.5.1 Alarm requirements*.

Table 19.5.1 Alarm requirements

Item	Alarm	Note
Rudder position	—	Indication, see <i>Pt 5, Ch 19, 4.1 General 4.1.3</i>
	Failure	See <i>Pt 5, Ch 19, 5.3 Monitoring and alarms 5.3.3</i>
Steering gear power units, power	Failure	—
Steering gear motors	Overload, Single phase	For alarm and running indication locations, see <i>Pt 5, Ch 19, 5.1 Electric power circuits 5.1.3</i> and <i>Pt 5, Ch 19, 5.1 Electric power circuits 5.1.4</i>
Control system	Failure	See <i>Pt 5, Ch 19, 5.3 Monitoring and alarms 5.3.3</i>
Control system power	Failure	—
Steering gear hydraulic oil tank level	Low	Each reservoir to be monitored. For alarm locations, see <i>Pt 5, Ch 19, 5.1 Electric power circuits 5.1.5</i>
Auto pilot	Failure	Running indication
Hydraulic oil temperature	High	Where oil cooler is fitted
Hydraulic lock	Fault	Where more than one system (either power or control) can be operated simultaneously each system is to be monitored, see Note

Hydraulic oil filter differential pressure	High	When oil filters are fitted
NOTE		
This alarm is to identify the system at fault and to be activated when (for example):		
<ul style="list-style-type: none"> • position of the variable displacement pump control system does not correspond with given order; or • incorrect position of 3-way full flow valve or similar in constant delivery pump system is detected. 		

5.3.2 The alarms described in *Table 19.5.1 Alarm requirements* are to be indicated on the navigating bridge and the additional locations described and are to be in accordance with the alarm system specified by *Pt 6, Ch 1, 2.3 Alarm systems, general requirements*.

5.3.3 Steering control systems are to be monitored and an audible and visual alarm is to be initiated on the navigation bridge in the event of:

- failure of the control system, including command and feedback circuits; or
- unacceptable deviation between the rudder order and actual rudder position and/or unacceptable delay in response to changes in the rudder order.

■ Section 6 Emergency power

6.1 General

6.1.1 Where the rudder stock is required to be over 230 mm diameter in way of the tiller, excluding strengthening for navigation in ice, or for ships fitted with podded propulsion units or water jet systems where the power per propulsion unit exceeds 2,500 kW, an alternative power supply, sufficient at least to supply the steering arrangements which comply with the requirements of *Pt 5, Ch 19, 2.1 General 2.1.3* and also its associated control system and the steering angle indicator, is to be provided automatically, within 45 seconds, either from the emergency source of electrical power or from an independent source of power located in the steering gear compartment. This independent source of power shall be used only for this purpose.

6.1.2 In every ship of 10 000 gross tonnage and upwards, the alternative power supply shall have a capacity for at least 30 minutes of continuous operation and in any other ship for at least 10 minutes.

6.1.3 Where the alternative power source is a generator, or an engine driven pump, starting arrangements are to comply with the requirements relating to the starting arrangements of emergency generators.

■ Section 7 Testing and trials

7.1 Testing

7.1.1 The requirements of the Rules relating to the testing of Class 1 pressure vessels, piping, and related fittings including hydraulic testing apply.

7.1.2 After installation on board the vessel the steering gear is to be subjected to the required hydrostatic and running tests.

7.1.3 Each type of power unit pump is to be subjected to a type test. The type test shall be for a duration of not less than 100 hours, the test arrangements are to be such that the pump may run in idling conditions, and at maximum delivery capacity at maximum working pressure. During the test, idling periods are to be alternated with periods at maximum delivery capacity at maximum working pressure. The passage from one condition to another should occur at least as quickly as on board. During the whole test no abnormal heating, excessive vibration or other irregularities are permitted. After the test, the pump is to be opened out and inspected. Type tests may be waived for a power unit which has been proven to be reliable in marine service.

7.2 Trials

7.2.1 The steering gear is to be tried out on the trial trip in order to demonstrate to the Surveyor's satisfaction that the requirements of the Rules have been met. The trial is to include the operation of the following:

- (a) The steering gear, including demonstration of the performances required by *Pt 5, Ch 19, 2.1 General 2.1.2* and *Pt 5, Ch 19, 2.1 General 2.1.3*:
 - For the main steering gear trial, the propeller pitch of controllable pitch propellers is to be at the maximum design pitch approved for the maximum continuous ahead RPM;
 - If the ship cannot be tested at the deepest draught, then the loading condition can be accepted on the conditions that either the rudder is fully submerged (at zero speed waterline) and the vessel is in an acceptable trim condition, or the rudder load and torque at the trial loading condition have been reliably predicted and extrapolated to the full load condition, to the satisfaction of the Administration. In any case, for the main steering gear trial, the speed of the ship corresponding to the maximum continuous revolutions of main engine and maximum design pitch applies;
- (b) The steering gear power units, including transfer between steering gear power units;
- (c) The isolation of one power actuating system, checking the time for regaining steering capability;
- (d) The hydraulic fluid recharging system;
- (e) The emergency power supply required by *Pt 5, Ch 19, 6.1 General 6.1.1*;
- (f) The steering gear controls, including transfer of control and local control;
- (g) The means of communication between the steering gear compartment and the wheelhouse, also the engine room, if applicable;
- (h) The alarms and indicators;
- (i) Where the steering gear is designed to avoid hydraulic locking this feature shall be demonstrated.

Test items *Pt 5, Ch 19, 7.2 Trials 7.2.1*, *Pt 5, Ch 19, 7.2 Trials 7.2.1*, *Pt 5, Ch 19, 7.2 Trials 7.2.1* and *Pt 5, Ch 19, 7.2 Trials 7.2.1* may be effected at the dockside.

7.2.2 The ability of the machinery to reverse the direction of thrust in sufficient time and bring the ship to rest within a reasonable distance from maximum ahead service speed is to be demonstrated and recorded.

7.2.3 The stopping times, ship headings and distances recorded on trials, together with the results of trials to determine the ability of ships having multiple propulsion/steering arrangements to navigate and manoeuvre with one or more of these devices inoperative, shall be available on board for the use of the Master or designated personnel.

■ Section 8 Additional requirements

8.1 For tankers, chemical tankers, or gas carriers of 10 000 tons gross and upwards and every other ship of 70 000 tons gross and upwards

8.1.1 The main steering gear is to comprise two or more identical power units complying with provisions of *Pt 5, Ch 19, 2.1 General 2.1.4*.

8.2 For tankers, chemical tankers or gas carriers of 10 000 tons gross and upwards

8.2.1 Subject to *Pt 5, Ch 19, 8.3 For tankers, chemical tankers or gas carriers of 10 000 tons gross and upwards but of less than 100 000 tons deadweight* the following are to be complied with:

- (a) The main steering gear is to be so arranged that in the event of loss of steering capability due to a single failure in any part of one of the power actuating systems of the main steering gear, excluding the tiller, quadrant or components serving the same purpose, or seizure of the rudder actuators, steering capability is to be regained in not more than 45 seconds after the loss of one power actuating system.
- (b) The main steering gear is to comprise either:
 - (i) two independent and separate power actuating systems, each capable of meeting the requirements of *Pt 5, Ch 19, 2.1 General 2.1.2*; or

- (ii) at least two identical power actuating systems which, acting simultaneously in normal operation, are capable of meeting the requirements of *Pt 5, Ch 19, 2.1 General 2.1.2*. Where necessary to comply with these requirements, inter-connection of hydraulic power actuating systems is to be provided. Loss of hydraulic fluid from one system is to be capable of being detected and the defective system automatically isolated so that the other actuating system or systems remain fully operational.
- (c) Steering gears other than of the hydraulic type are to achieve equivalent Standards.

8.3 For tankers, chemical tankers or gas carriers of 10 000 tons gross and upwards but of less than 100 000 tons deadweight

8.3.1 Solutions other than those set out in *Pt 5, Ch 19, 8.2 For tankers, chemical tankers or gas carriers of 10 000 tons gross and upwards 8.2.1* which need not apply the single failure criterion to the rudder actuator or actuators, may be permitted provided that an equivalent safety Standard is achieved and that:

- (a) Following loss of steering capability due to a single failure of any part of the piping system or in one of the power units, steering capability is regained within 45 seconds; and
- (b) Where the steering gear includes only a single rudder actuator special consideration is given to stress analysis for the design including fatigue analysis and fracture mechanics analysis, as appropriate, the material used, the installation of sealing arrangements and the testing and inspection and provision of effective maintenance. In consideration of the foregoing, regard will be given to the 'Guidelines' in *Pt 5, Ch 19, 9 'Guidelines' for the acceptance of non-duplicated rudder actuators for tankers, chemical tankers and gas carriers of 10 000 tons gross and upwards but of less than 100 000 tons deadweight*.

8.3.2 Manufacturers of steering gear who intend their product to comply with the requirements of the 'Guidelines' are to submit full details when plans are forwarded for approval.

■ Section 9 **'Guidelines' for the acceptance of non-duplicated rudder actuators for tankers, chemical tankers and gas carriers of 10 000 tons gross and upwards but of less than 100 000 tons deadweight**

9.1 Materials

9.1.1 Parts subject to internal hydraulic pressure or transmitting mechanical forces to the rudder-stock are to be made of duly tested ductile materials complying with recognised Standards. Materials for pressure retaining components are to be in accordance with recognised pressure vessel Standards. These materials are not to have an elongation less than 12 per cent nor a tensile strength in excess of 650 N/mm².

9.2 Design

9.2.1 **Design pressure.** The design pressure should be assumed to be at least equal to the greater of the following:

- (a) 1,25 times the maximum working pressure to be expected under the operating conditions required in *Pt 5, Ch 19, 2.1 General 2.1.2*.
- (b) The relief valve(s) setting.

9.2.2 **Analysis.** In order to analyse the design the following are required:

- (a) The manufacturers of rudder actuators should submit detailed calculations showing the suitability of the design for the intended service.
- (b) A detailed stress analysis of pressure retaining parts of the actuator should be carried out to determine the stresses at the design pressure.
- (c) Where considered necessary because of the design complexity or manufacturing procedures, a fatigue analysis and fracture mechanics analysis may be required. In connection with these analyses, all foreseen dynamic loads should be taken into account. Experimental stress analysis may be required in addition to, or in lieu of, theoretical calculations depending upon the complexity of the design.

9.2.3 **Dynamic loads for fatigue and fracture mechanics analysis.** The assumption for dynamic loading for fatigue and fracture mechanics analysis where required by *Pt 5, Ch 19, 3.1 General 3.1.5, Pt 5, Ch 19, 8.3 For tankers, chemical tankers or*

gas carriers of 10 000 tons gross and upwards but of less than 100 000 tons deadweight and Pt 5, Ch 19, 9.2 Design 9.2.2 are to be submitted for appraisal. Both the case of high cycle and cumulative fatigue are to be considered.

9.2.4 **Allowable stresses.** For the purpose of determining the general scantlings of parts of rudder actuators subject to internal hydraulic pressure the allowable stresses should not exceed:

$$\sigma_m \leq f$$

$$\sigma_1 \leq 1,5f$$

$$\sigma_b \leq 1,5f$$

$$\sigma_1 + \sigma_b \leq 1,5f$$

$$\sigma_m + \sigma_b \leq 1,5f$$

where

$$f = \text{thelesserof } \frac{\sigma_B}{A} \text{ or } \frac{\sigma_y}{B}$$

σ_b = equivalent primary bending stress

σ_m = equivalent primary general membrane stress

σ_y = specified minimum yield stress or 0,2 per cent proof stress of material at ambient temperature

σ_B = specified minimum tensile strength of material at ambient temperature

σ_1 = equivalent primary local membrane stress

A and B are as follows:

	Wrought steel	Cast steel	Nodular cast iron
A	4	4,6	5,8
B	2	2,3	3,5

9.2.5 **Burst test.** Pressure retaining parts not requiring fatigue analysis and fracture mechanics analysis may be accepted on the basis of a certified burst test and the detailed stress analysis required by Pt 5, Ch 19, 9.2 Design 9.2.2 need not be provided.

The minimum bursting pressure should be calculated as follows:

$$P_b = PA \frac{\sigma_{Ba}}{\sigma_B}$$

where

A = as from table in Pt 5, Ch 19, 9.2 Design 9.2.4

P = design pressure as defined in Pt 5, Ch 19, 9.2 Design 9.2.1

P_b = minimum bursting pressure

σ_B = tensile strength as defined in Pt 5, Ch 19, 9.2 Design 9.2.4

σ_{Ba} = actual tensile strength.

9.3 Construction details

9.3.1 **General.** The construction should be such as to minimise local concentrations of stress.

9.3.2 **Welds.**

(a) The welding details and welding procedures should be approved.

(b) All welded joints within the pressure boundary of a rudder actuator or connection parts transmitting mechanical loads should be full penetration type or of equivalent strength.

9.3.3 **Oil seals.** Oil seals forming part of the external pressure boundary are to comply with *Pt 5, Ch 19, 3.2 Components 3.2.3* and *Pt 5, Ch 19, 3.2 Components 3.2.4*.

9.3.4 **Isolating valves** are to be fitted at the connection of pipes to the actuator, and should be directly mounted on the actuator.

9.3.5 **Relief valves** for protecting the rudder actuator against over-pressure as required in *Pt 5, Ch 19, 3.3 Valve and relief valve arrangements 3.3.3* are to comply with the following:

- (a) The setting pressure is not to be less than 1,25 times the maximum working pressure expected under operating conditions required by *Pt 5, Ch 19, 2.1 General 2.1.2*.
- (b) The minimum discharge capacity of the relief valve(s) is to be not less than 110 per cent of the total capacity of all pumps which provide power for the actuator. Under such conditions the rise in pressure should not exceed 10 per cent of the setting pressure. In this regard due consideration should be given to extreme foreseen ambient conditions in respect of oil viscosity.

9.4 Non-destructive testing

9.4.1 The rudder actuator should be subjected to suitable and complete non-destructive testing to detect both surface flaws and volumetric flaws. The procedure and acceptance criteria for non-destructive testing should be in accordance with requirements of recognised Standards. If found necessary, fracture mechanics analysis may be used for determining maximum allowable flaw size.

9.5 Testing

9.5.1 Tests, including hydrostatic tests, of all pressure parts at 1,5 times the design pressure should be carried out subject to any limitations imposed by valves and other components. Where additional testing of systems or subsystems following final assembly is required, the test pressure may be subject to any limitations imposed by valves and other components.

9.5.2 When installed on board the ship, the rudder actuator should be subjected to a hydrostatic test at the pressure defined in *Pt 5, Ch 19, 9.5 Testing 9.5.1* and a running test.

9.6 Additional requirements for steering gear fitted to ships with Ice Class notations

9.6.1 *See Pt 3, Ch 9 Special Features.*

Section

- 1 **General requirements**
 - 2 **Performance**
 - 3 **Construction and design**
 - 4 **Control engineering arrangements**
 - 5 **Electrical equipment**
 - 6 **Testing and trials**
-

■ *Section 1*
General requirements

1.1 Application

1.1.1 This Chapter applies to azimuth or rotatable thruster units, for propulsion or D.P. duty which transmit a power greater than 220 kW used as the sole means of steering and are in addition to the relevant requirements of *Pt 5, Ch 19 Steering Arrangements*.

1.1.2 In general, for a vessel to be assigned an unrestricted service notation a minimum of two azimuth thruster units are to be provided where these form the sole means of propulsion. Where a single thruster installation is proposed, it will be subject to special consideration.

1.2 Plans

1.2.1 The following additional plans are to be submitted for consideration together with particulars of materials and the maximum shaft power and revolutions per minute:

- Sectional assembly including nozzle ring structure, nozzle support struts, etc.
 - Shafts, gears and couplings.
 - Steering mechanisms with details of ratings.
 - Bearing specifications.
 - Schematic piping systems.
-

■ *Section 2*
Performance

2.1 General

2.1.1 The arrangement of thrusters is to be such that the ship can be satisfactorily manoeuvred.

2.1.2 For vessels with multiple azimuthing thrusters, the requirement for auxiliary steering arrangements in *Pt 5, Ch 19, 2 Performance* is to be achieved by equipping each of the azimuthing thrusters with its own dedicated and independent steering gear control system and power actuating system. Consideration will be given to alternative arrangements providing equivalence can be demonstrated.

2.1.3 In general, the steering systems and components are to comply with the requirements of *Pt 5, Ch 19 Steering Arrangements*. The requirements of *Pt 5, Ch 19, 2.1 General 2.1.2* and *Pt 5, Ch 19, 2.1 General 2.1.2* are addressed by *Pt 5, Ch 20, 2.1 General 2.1.5* and the requirements of *Pt 5, Ch 19, 2.1 General 2.1.3* and *Pt 5, Ch 19, 2.1 General 2.1.3* are addressed by *Pt 5, Ch 20, 2.1 General 2.1.6*.

2.1.4 In addition to the requirements of *Pt 5, Ch 19 Steering Arrangements*, the azimuthing mechanism is to be capable of a rotational speed of not less than 1,5 rev/min.

2.1.5 The main steering arrangements are to be operated by power and capable of changing the direction of the ship's azimuth thrusters from one side to the other at declared steering angle limits at an average rotational speed of not less than 0,4 rev/min, with the ship running ahead at maximum ahead service speed.

2.1.6 The auxiliary steering arrangements are to be:

- (a) Capable of changing the direction of the ship's azimuth thrusters from one side to the other at declared steering angle limits at an average rotational speed of not less than 0,083 rev/min, with the ship running ahead at one half of the maximum ahead service speed or 7 knots, whichever is the greater.
- (b) Operated by power for ships having propulsion power of more than 2500 kW per thruster unit and for all ships, where it is necessary, to meet the requirements of *Pt 5, Ch 20, 2.1 General 2.1.6*.

■ **Section 3**
Construction and design

3.1 Materials

3.1.1 Specification for materials of gears, shafts, couplings and propeller, giving chemical composition, heat treatment and mechanical properties are to be submitted for approval.

3.1.2 Specification for materials for the stock, struts, etc. are to be submitted for approval.

3.1.3 Where an ice class notation is included in the class of a ship, additional requirements are applicable as detailed in *Pt 8 Rules for Ice and Cold Operations* and *Pt 3, Ch 9 Special Features*.

3.2 Design

3.2.1 The requirements detailed in *Pt 5, Ch 1 General Requirements for the Design and Construction of Machinery*, *Pt 5, Ch 5 Gearing*, *Pt 5, Ch 6 Main Propulsion Shafting*, *Pt 5, Ch 7 Propellers*, *Pt 5, Ch 8 Shaft Vibration and Alignment*, *Pt 5, Ch 9 Podded Propulsion Units*, *Pt 5, Ch 14 Machinery Piping Systems* and *Pt 5, Ch 19 Steering Arrangements* are to be complied with where applicable.

3.2.2 For steerable thrusters with a nozzle, the equivalent rudder stock diameter in way of tiller, used in *Table 19.1.1 Connection of tiller to stock* in Chapter 19, is to be determined as follows:

$$\delta_t = 26,03 \sqrt[3]{(V + 3)^2 A_N x_P} \text{ mm}$$

where

V = maximum service speed, in knots, which the ship is designed to maintain under thruster operation

A_N = projected nozzle area, in m^2 , and is equal to the length of the nozzle multiplied by the mean external vertical height of the nozzle and

x_P = horizontal distance from the centreline of the steering tube to the centre of pressure, in metres. The position of the centre of pressure is determined for both ahead and astern cases from *Pt 3, Ch 13, 2.3 Rudder torque calculation for rudders without cut-outs 2.3.1*.

The corresponding maximum turning moment, M_T , is to be determined as follows:

M_T = turning moment for conical couplings and is to be taken as the greatest of M_F , M_A or M_W

M_F = $P_L x_P \times 10^6$ N mm (kgf mm) in the ahead condition

M_A = $P_L x_P \times 10^6$ N mm (kgf mm) in the astern condition

M_W = the torque generated by the steering gear at the maximum working pressure supplied by the manufacturer, in N mm (kgf mm). M_W is not to exceed the greater of $3,0M_F$ or $3,0M_A$

P_L = lateral force on rudder acting at centre of pressure, as defined in Pt 3, Ch 13, 2.2 Lateral force on rudder blade 2.2.1 (where A_R equals $2A_N$), in kN (tonne-f).

3.2.3 The nozzle structure is to be in accordance with Pt 3, Ch 13, 3 Fixed and steering nozzles.

3.2.4 In addition to the requirements of Table 13.3.1 Nozzle construction requirements, in Pt 3, Ch 13 Ship Control Systems, the scantlings of the nozzle stock or steering tube are to be such that the section modulus against transverse bending at any section xx is not less than:

$$Z = 1,73 \sqrt{(V + 3)^4 A_N^2 x_P^2 + \frac{2a^2}{4} T_M^2} \cdot 10^4 \text{ cm}^3$$

where

a = dimension, in metres, as shown in Figure 20.3.1 Steerable thruster

T_M = maximum thrust of the thruster unit in tonnes

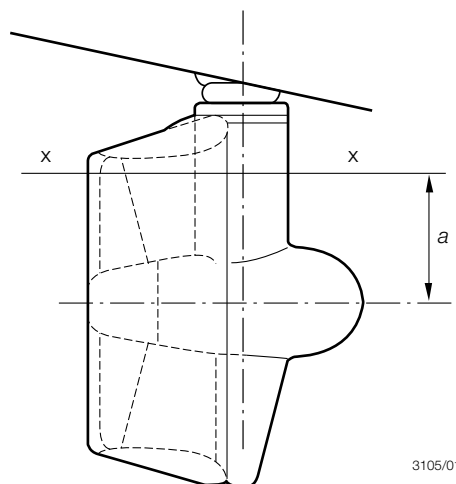

Figure 20.3.1 Steerable thruster

3.2.5 The scantlings of nozzle connections or struts will be specially considered. In the case of certain high powered ships, direct calculation may be required.

3.2.6 For steerable thrusters without a nozzle the scantlings in way of the tiller will be specially considered.

3.3 Steering gear elements

3.3.1 These gears are to be considered for the following conditions:

- a design maximum dynamic duty steering torque;
- a static duty ($\leq 10^3$ load cycles) steering torque, and the static duty steering torque should be not less than M_T .

Values for the above should be submitted together with the plans.

3.4 Components

3.4.1 The hydraulic power operating systems for each azimuth thruster are to be provided with the following:

- (a) arrangements to maintain the cleanliness of the hydraulic fluid, taking into consideration the type and design of the hydraulic system;

- (b) a fixed storage tank having sufficient capacity to recharge at least one azimuth power actuating system including the reservoir. The piping from the storage tank is to be permanent and arranged in such a manner as to allow recharging from within the thruster space.

■ *Section 4*
Control engineering arrangements

4.1 General

4.1.1 Except where indicated in this Section the control engineering systems are to be in accordance with *Pt 6, Ch 1 Control Engineering Systems*.

4.1.2 Steering control is to be provided for the azimuth thrusters from the navigating bridge, the main machinery control station and locally.

4.1.3 An indication of the angular position of the thruster(s) and the magnitude of the thrust are to be provided at each station from which it is possible to control the direction of thrust.

4.1.4 Means are to be provided at the remote control station(s) to stop each thrust unit.

4.2 Monitoring and alarms

4.2.1 Alarms and monitoring requirements are indicated in *Pt 5, Ch 20, 4.2 Monitoring and alarms 4.2.2* and *Table 20.4.1 Alarms for control systems*.

Table 20.4.1 Alarms for control systems

Item	Alarm	Note
Thruster azimuth	-	Indicator, see <i>Pt 5, Ch 20, 4.1 General 4.1.3</i>
Steering motor	Power failure, single phase	Also running indication on bridge and at machinery control station
Propulsion motor	Overload, power failure	Also running indication on bridge and at machinery control station
Control system power	Failure	
Hydraulic oil supply tank level	Low	
Hydraulic oil system pressure	Low	
Hydraulic oil system temperature	High	Where oil cooler is fitted
Hydraulic oil filters differential pressure	High	Where oil filters are fitted
Lubricating oil supply	Low	If separate forced lubrication

4.2.2 The alarms described in *Table 20.4.1 Alarms for control systems* are to be indicated individually on the navigating bridge and in accordance with the alarm system specified by *Pt 6, Ch 1, Pt 6, Ch 1, 2.3 Alarm systems, general requirements*.

■ *Section 5*
Electrical equipment

5.1 General

5.1.1 The electrical installation is to be designed, constructed and installed in accordance with the requirements of *Pt 5, Ch 20, 5.2 Generating arrangements* to *Pt 5, Ch 20, 5.4 Auxiliary supplies*.

5.1.2 Where the thruster units are electrically driven the relevant requirements, including surveys, of *Pt 6, Ch 2 Electrical Engineering* are to be complied with.

5.2 Generating arrangements

5.2.1 Where a central power generation system is employed, the requirements of *Pt 6, Ch 2, 16.3 Power requirements 16.3.5* are to be complied with.

5.2.2 The generating and distribution system is to be so arranged that after any single failure, steering capability can be maintained or regained within a period not exceeding 45 seconds, and the effectiveness of the steering after such a fault will not be reduced by more than 50 per cent. This may be achieved by the parallel operation of two or more generating sets, or alternatively when the electrical requirements may be met by one generating set in operation, on loss of power, the automatic starting and connection to the switchboard of a standby set, provided that this set can restart and run a thruster with its auxiliaries.

5.2.3 The failure of one thruster unit or its control system is not to render any other thruster inoperative.

5.3 Distribution arrangements

5.3.1 Thruster auxiliaries and controls are to be served by individual circuits. Services that are duplicated are to be separated throughout their length as widely as is practicable and without the use of common feeders, transformers, converters, protective devices or control circuits.

5.4 Auxiliary supplies

5.4.1 Where the auxiliary services and thruster units are supplied from a common source, the following requirements are to be complied with:

- (a) the voltage regulation and current sharing requirements defined in *Pt 6, Ch 2, 9.4 Generator control 9.4.2* and *Pt 6, Ch 2, 9.4 Generator control 9.4.7* are to be maintained over the full range of power factors that may occur in service,
- (b) auxiliary equipment and services are to operate with any waveform distortion introduced by converters without deleterious effect. (This may be achieved by the provision of suitably filtered/converted supplies).

■ Section 6 Testing and trials

6.1 General

6.1.1 The requirements detailed in *Pt 5, Ch 1 General Requirements for the Design and Construction of Machinery, Pt 5, Ch 5 Gearing* and *Pt 5, Ch 19 Steering Arrangements* are to be complied with and, in addition, the performance specified in *Pt 5, Ch 20, 2.1 General 2.1.2* is to be demonstrated to the Surveyor's satisfaction.

6.1.2 The actual values of steering torque should be verified during sea trials to confirm that the design maximum dynamic duty torque has not been exceeded.

Requirements for Condition Monitoring Systems and Machinery Condition-Based Maintenance Systems

Part 5, Chapter 21

Section 1

Section

1 Requirements for Condition Monitoring Systems and Machinery Condition-Based Maintenance Systems

■ Section 1 Requirements for Condition Monitoring Systems and Machinery Condition-Based Maintenance Systems

1.1 Scope

1.1.1 The requirements of this Chapter are applicable to condition monitoring systems and machinery condition-based maintenance systems which:

- (a) provide control, alarm or safety functions for essential machinery and equipment (see *Pt 6, Ch 1, 2.1 General 2.1.1*) in accordance with manufacturers recommendations; or
- (b) provide machinery condition related information as part of a machinery planned maintenance scheme for use as an alternative to machinery and equipment surveys required by the Regulations (see *Pt 1, Ch 3 Periodical Survey Regulations*) in accordance with LR's ShipRight procedures.

1.1.2 Condition monitoring systems which deviate from the requirements of this Section but provide an equivalent level of performance may be submitted to LR for consideration.

1.1.3 The requirements of this Section are to be applied to condition monitoring systems where the assignment of the **MCM** descriptive note is requested.

1.1.4 The requirements of this Section are to be applied to machinery condition-based maintenance systems where the assignment of the **MCBM** Descriptive Note is requested in addition to the **MCM** Descriptive Note.

1.2 Plans and particulars

1.2.1 The information and plans required to be submitted are as specified in the relevant Chapters of *Pt 5 Main and Auxiliary Machinery* and *Pt 6 Control, Electrical, Refrigeration and Fire* applicable to the particular machinery and where specified in this Chapter.

1.2.2 In addition to information required by *Pt 5, Ch 21, 1.2 Plans and particulars 1.2.1*, the documents listed in the *ShipRight Procedures for Machinery Planned Maintenance and Condition Monitoring* are to be submitted to LR for consideration.

1.2.3 In addition to information required by *Pt 5, Ch 21, 1.2 Plans and particulars 1.2.1*, the documents listed in the *ShipRight Procedures for Machinery Planned Maintenance and Condition Monitoring* are to be submitted to LR for consideration where the **MCBM** Descriptive Note is requested.

1.2.4 Equipment type approval reports providing evidence of compliance with *Pt 5, Ch 21, 1.3 General requirements for condition monitoring systems 1.3.1* and *Pt 5, Ch 21, 1.3 General requirements for condition monitoring systems 1.3.2* are to be submitted.

1.2.5 Additional information and plans providing evidence of compliance with the requirements of *Pt 5, Ch 21, 1.3 General requirements for condition monitoring systems 1.3.3*, *Pt 5, Ch 21, 1.4 Requirements for systems providing control, alarm and safety functions 1.4.1* and *Pt 5, Ch 21, 1.5 Requirements for systems providing machinery condition related information as part of machinery condition-based maintenance systems 1.5.4* are to be submitted.

1.3 General requirements for condition monitoring systems

1.3.1 Condition monitoring equipment is to be capable of providing the service for which it is intended and is to satisfy the relevant requirements for condition monitoring equipment in LR's Type Approval System, *Product Assessment and Test Specification (TACM)*.

1.3.2 Condition monitoring equipment is to be suitable for the environment in which it is intended to operate and is to satisfy the relevant requirements for environmental testing in LR's Type Approval System, *Test specification No. 1*.

Requirements for Condition Monitoring Systems and Machinery Condition-Based Maintenance Systems

Part 5, Chapter 21

Section 1

1.3.3 The installation of condition monitoring equipment in spaces and locations in which flammable mixtures are liable to collect, e.g. ,areas containing flammable gas or vapour and/or combustible dust, is to be minimised as far as is practicable and is to satisfy the relevant requirements for the use of electrical equipment in flammable atmospheres in *Pt 6, Ch 2, 14 Electrical equipment for use in explosive gas atmospheres or in the presence of combustible dusts*.

1.3.4 Where permanently installed condition monitoring systems are used, the cables are to comply with the relevant Sections of *Pt 6, Ch 2, 11 Electric cables, optical fibre cables and busbar trunking systems (busways)* and the piping systems are to comply with relevant Sections of *Pt 5, Ch 12 Piping Design Requirements* and *Pt 5, Ch 13 Ship Piping Systems*.

1.3.5 Where the system is based on programmable electronic systems, the requirements of *Pt 6, Ch 1, 3.6 Displays 3.6.3* are to be complied with.

1.3.6 Portable condition monitoring equipment is to be maintained and calibrated in accordance with a recognised National or International Standard to ensure the accuracy of the readings obtained. The standard is to include the issue of calibration certificates by a recognised test house in accordance with a recognised National or International Standard for instrument calibration. Copies of calibration certificates are to be retained on board and referenced on all condition monitoring reports submitted as part of the onboard condition monitoring program. Portable equipment used in hazardous areas is to be of a safe type suitable for use in the appropriate hazardous zone.

1.3.7 Measuring points are to be clearly identified in the submission and proposals to ensure repeatability of measurements are to be included.

1.3.8 The condition monitoring equipment is, as far as is practicable, to be located and installed such that it is accessible for maintenance and survey.

1.3.9 The condition monitoring equipment is to be installed in accordance with the manufacturer's instructions, see the *Product Assessment and Test Specification (PACM)*, or by an approved technical organisation as defined in the *LR ShipRight Procedures for Machinery Planned Maintenance and Condition Monitoring*, and to the satisfaction of the LR Surveyor.

1.4 Requirements for systems providing control, alarm and safety functions

1.4.1 In addition to the requirements of *Pt 5, Ch 21, 1.3 General requirements for condition monitoring systems*, condition monitoring equipment which provides control, alarm or safety functions for essential machinery and equipment is also to satisfy the relevant requirements for control, alarm and safety systems in *Pt 6, Ch 1 Control Engineering Systems* and the installation of electrical equipment in *Pt 6, Ch 2 Electrical Engineering*.

1.5 Requirements for systems providing machinery condition related information as part of machinery condition-based maintenance systems

1.5.1 In addition to the requirements of *Pt 5, Ch 21, 1.3 General requirements for condition monitoring systems*, condition monitoring equipment which provides machinery condition related information as part of a machinery planned maintenance scheme for use as an alternative to machinery and equipment surveys required by the Regulations is also to satisfy the relevant requirements of LR's *ShipRight Procedures for Machinery Planned Maintenance and Condition Monitoring*.

1.5.2 Where condition monitoring data is used as part of a machinery condition-based maintenance system, persons interpreting data and making diagnostic decisions are to be suitably competent, in accordance with ISO 18436 or an equivalent recognised National Standard. Evidence of competence, including training certificates of those providing analysis and data interpretation, are to be submitted and held on board. These certificates are to be made available to LR on request for audit and survey purposes.

1.5.3 The condition monitoring equipment is, as far as is practicable, to be located and installed such that it is accessible for maintenance and survey.

1.5.4 The condition monitoring equipment is to be installed in accordance with the manufacturer's instructions, see the *Product Assessment and Test Specification (TACM)* or by an approved technical organisation as defined in the *ShipRight Procedures for Machinery Planned Maintenance and Condition Monitoring*, and to the satisfaction of the LR Surveyor.

1.6 Requirements for machinery condition-based maintenance systems

1.6.1 Any vessel applying to operate a machinery condition-based maintenance system with the **MCBM** Descriptive Note is also to have an approved planned maintenance system in place with the **MPMS** Descriptive Note assigned.

1.6.2 Where a **MCBM** Descriptive Notation is requested and a vessel operates both an approved continuous machinery (CSM) survey cycle and has an approved machinery condition monitoring system in place which meets the requirements of the

Requirements for Condition Monitoring Systems and Machinery Condition-Based Maintenance Systems

Part 5, Chapter 21

Section 1

MCM Descriptive Notation, the **MCBM** Descriptive Notation is to be taken to mean that the vessel complies with the requirements of the **MCM** notation, however, the **MCM** Descriptive Notation will not be assigned.

1.6.3 Proposals for machinery condition-based maintenance systems are to be submitted for approval and are to meet the requirements of LR's *ShipRight Procedures for Machinery Planned Maintenance and Condition Monitoring*, and be to the satisfaction of the LR Surveyor. This plan is to include proposals for returning the vessel to a conventional maintenance and survey regime, and withdrawal of the **MCBM** Descriptive Notation, if the Owner decides for any reason to withdraw from condition-based maintenance or if the vessel should change ownership and the new Owners do not wish to retain the **MCBM** Descriptive Note.

1.6.4 Machinery condition-based maintenance systems are to be developed in accordance with the methodology given in ISO 17359 or an equivalent recognised National Standard.

1.6.5 Proposals are to identify those items of machinery and equipment which are to be maintained according to their condition and those which are to be maintained in accordance with manufacturer's time-based and running hours-based service and maintenance requirements. To assess which items are to be maintained according to their condition, a criticality assessment is to be carried out.

1.6.6 The criticality assessment is to include a FMEA/FMECA assessment and is to take account of:

- machinery and equipment redundancy;
- failure rate and mean time to repair;
- local effects of failure on the safe operation of the machinery and equipment; and
- wider effects of failure on the ship's essential services and the safe operation of the ship, including environmental impact.

The criticality assessment is included in the submission for approval in accordance with LR's *ShipRight Procedures for Machinery Planned Maintenance and Condition Monitoring*, as stated in *Pt 5, Ch 21, 1.6 Requirements for machinery condition-based maintenance systems 1.6.3*, and is to be to the satisfaction of the LR Surveyor.

1.6.7 Boilers and pressure vessels are not eligible for condition-based monitoring.

1.6.8 For all machinery and equipment which is proposed for maintenance based on condition monitoring data, in addition to the criticality assessment in *Pt 5, Ch 21, 1.6 Requirements for machinery condition-based maintenance systems 1.6.5*, evidence is to be submitted which demonstrates that the condition of the machinery and equipment can be measured accurately and that the measured parameters are clearly defined in the condition monitoring plan.

1.6.9 Machinery condition monitoring is to meet the requirements of *Pt 5, Ch 21, 1.3 General requirements for condition monitoring systems* and *Pt 5, Ch 21, 1.5 Requirements for systems providing machinery condition related information as part of machinery condition-based maintenance systems*; in addition, the machinery condition-based maintenance plan is to include guidance on parameter limit values, trend analysis and fault diagnosis. This requirement for guidance information does not remove the requirement for those persons with responsibility for analysing condition monitoring data to be suitably trained and competent, in accordance with *Pt 5, Ch 21, 1.5 Requirements for systems providing machinery condition related information as part of machinery condition-based maintenance systems 1.5.2*.

1.6.10 As part of the criticality assessment, it is to be demonstrated that any machinery included in the list of items for condition-based maintenance shall have measurable performance parameters which will give adequate warning of machinery deterioration that may result in failure, to allow maintenance to be scheduled in advance of such failure.

1.6.11 The condition-based maintenance plan is to maintain records of all data included in the plan approval document. The plan shall include proposals for:

- essential data describing the machine;
- essential data describing operating conditions;
- the measurement position;
- the measured quantity units and processing; and
- date and time information.

These records are to be available on request to any LR Surveyor or representative.

1.6.12 Proposals to ensure repeatability of results are to be submitted for approval.

1.6.13 Those items of machinery and equipment which are subject to a mandatory five-year survey are still required to be surveyed by a LR Surveyor at intervals not exceeding five years. A list of these items is to be found in LR's *ShipRight Procedures for Machinery Planned Maintenance and Condition Monitoring*.

Requirements for Condition Monitoring Systems and Machinery Condition-Based Maintenance Systems

Part 5, Chapter 21

Section 1

1.6.14 For items which are not suitable for condition-based maintenance, see *Pt 5, Ch 21, 1.6 Requirements for machinery condition-based maintenance systems 1.6.7*, the required maintenance will, as a minimum, comply with the equipment manufacturer's maintenance requirements.

1.6.15 The **MCBM** records, including diagnostic analysis and condition assessment reports, for items of machinery and equipment being maintained on the basis of condition monitoring data, are to be surveyed over a five-year continuous survey cycle, with 20 per cent of the records being subject to survey each year such that all records are surveyed over a five-year period.

Propulsion and Steering Machinery Redundancy

Part 5, Chapter 22

Section 1

Section

- 1 **General requirements**
- 2 **Failure Mode and Effects Analysis (FMEA)**
- 3 **Machinery arrangements**
- 4 **Control arrangements**
- 5 **Separate machinery spaces * (star) Enhancement**
- 6 **Testing and trials**

■ Section 1 General requirements

1.1 General

1.1.1 This Chapter states the requirements for ships having machinery redundancy, and are in addition to the relevant requirements in other relevant Sections of these Rules.

1.1.2 The requirements, which are optional, cover machinery arrangements and control systems necessary for ships which have propulsion and steering systems configured such that, in the event of a single failure of a system or item of active equipment, see *Pt 5, Ch 22, 1.1 General 1.1.3*, the ship will retain the ability to use available installed prime mover capacity and installed propulsion systems that are unaffected by the failure. The ship is also to retain steering capability at a service speed of not less than seven knots. The requirements also cover machinery arrangements where the propulsion and steering systems are installed in separate compartments such that, in the event of a loss of one compartment, the ship will retain availability of propulsion power and manoeuvring capability.

1.1.3 For the purpose of this Chapter, items of active equipment are those which have a defined function for operation of a propulsion or steering system, such as but not limited to:

- Prime movers, i.e. diesel engines, electric motors, steam turbines and gas turbines;
- Generators and their excitation equipment;
- Transformers and converters;
- Gearing and shafting systems;
- Propulsion devices, i.e. propellers, water jets and thrusters;
- Pumps;
- Valves (where power actuated);
- Fuel treatment plant;
- Coolers/heaters;
- Filters;

Piping and electrical cables connecting items of active equipment are not considered to be active.

1.1.4 Requirements additional to these Rules may be imposed by the Flag State with whom the ship is registered and/or by the Administration within whose territorial jurisdiction the ship is intended to operate.

1.1.5 *Pt 5, Ch 22, 2 Failure Mode and Effects Analysis (FMEA)*, *Pt 5, Ch 22, 3 Machinery arrangements* and *Pt 5, Ch 22, 4 Control arrangements* state the applicable requirements for arrangements necessary to maintain availability of propulsion and manoeuvring capability, in the event of a single failure in equipment. Ships complying with the applicable requirements of *Pt 5, Ch 22, 2 Failure Mode and Effects Analysis (FMEA)* to *Pt 5, Ch 22, 4 Control arrangements* will be eligible for the machinery class notation **PMR** or **PMRL** (Propulsion Machinery Redundancy), **SMR** or **SMRL** (Steering Machinery Redundancy) or **PSMR** or **PSMRL** (Propulsion and Steering Machinery Redundancy), which will be recorded in the *Register Book*.

Note The additional **L** character to **PMR**, **SMR** and **PSMR** notations indicates a limited capability.

Propulsion and Steering Machinery Redundancy

Part 5, Chapter 22

Section 1

1.1.6 *Pt 5, Ch 22, 5 Separate machinery spaces * (star) Enhancement* states the additional requirements necessary to maintain availability of propulsion and manoeuvring capability where machinery is installed in separate compartments and the loss of any one compartment due to fire or flooding has been addressed. Ships complying with the applicable requirements of *Pt 5, Ch 22, 2 Failure Mode and Effects Analysis (FMEA)* to *Pt 5, Ch 22, 5 Separate machinery spaces * (star) Enhancement* of this Chapter will be eligible for the machinery class notation **PMR *** or **PMRL *** (Propulsion Machinery Redundancy in separate machinery spaces), **SMR *** or **SMRL *** (Steering Machinery Redundancy in separate machinery spaces) or **PSMR *** or **PSMRL *** (Propulsion and Steering Machinery Redundancy in separate machinery spaces) which will be recorded in the *Register Book*.

1.1.7 For assignment of **PSMR** or **PSMR *** machinery class notations, the ship is to retain the ability to use not less than 50 per cent of the installed prime mover capacity and not less than 50 per cent of the installed propulsion systems and retain steering capability at a service speed of not less than seven knots in the event of a single failure of a system or item of equipment.

1.1.8 Where the ship does not comply with 1.1.7 but can retain a service speed of not less than seven knots using available installed prime mover capacity and propulsion systems (which may be less than 50 per cent) following a failure of a system or item of equipment, machinery class notations **PSMRL** or **PSMRL *** may be assigned. The available installed prime mover capacity and installed propulsion systems are to be identified and included in *Pt 5, Ch 22, 1.2 Plans and information 1.2.7*.

1.2 Plans and information

1.2.1 In addition to the plans and information required by *Pt 5 Main and Auxiliary Machinery* and *Pt 6 Control, Electrical, Refrigeration and Fire*, the information detailed in *Pt 5, Ch 22, 1.2 Plans and information 1.2.2* to *Pt 5, Ch 22, 1.2 Plans and information 1.2.6* is also to be submitted.

1.2.2 **Machinery spaces.** Plans showing the general arrangement of the machinery spaces, together with a description of the propulsion system, main and emergency electrical power supply systems and steering arrangements are to be submitted. The plans are to indicate segregation and access arrangements for machinery spaces and associated control rooms/stations.

1.2.3 **Failure Mode and Effects Analysis (FMEA).** For the propulsion systems, electrical power supplies, essential services, control systems and steering arrangements, a FMEA report is to be submitted and is to address the requirements identified in *Pt 5, Ch 22, 2 Failure Mode and Effects Analysis (FMEA)* and *Pt 5, Ch 22, 5 Separate machinery spaces * (star) Enhancement*.

1.2.4 **Manoeuvring capability.** An assessment of the ships' ahead and astern manoeuvring capability, under the following operating conditions, is to be submitted:

- (a) Where only 50 per cent or less of the installed prime mover capacity and 50 per cent or less of the installed propulsion systems are available.
- (b) Where the steering capability requirements described in *Pt 5, Ch 22, 3.2 Steering machinery 3.2.1* are available.

IMO Resolution MSC 137(76) – *Standards for Ship Manoeuvrability*, provides guidance, on standard manoeuvres required in an assessment of the manoeuvrability of ships.

1.2.5 **Testing and trials procedures.** A schedule of testing and trials to demonstrate that the ship is capable of being operated with machinery functioning as described in *Pt 5, Ch 22, 4.2 Bridge control* is to be submitted. In addition, any testing programme that may be necessary to prove the conclusions of the FMEA is to be submitted.

1.2.6 **Operating Manuals.** Operating Manuals are to be submitted for information and provided on board. The manuals are to include the following information:

- (a) Particulars of machinery and control systems.
- (b) General description of systems for propulsion and steering.
- (c) Operating instructions for all machinery and control systems used for propulsion and steering.
- (d) Procedures for dealing with the situations identified in the FMEA report.

1.2.7 **Installed prime mover capacity and installed propulsion systems.** A schedule of the propulsion systems and their operating capacity and capability under normal and foreseeable failure conditions is to be submitted.

Propulsion and Steering Machinery Redundancy

■ **Section 2**
Failure Mode and Effects Analysis (FMEA)

2.1 General

2.1.1 An FMEA is to be carried out in accordance with *Pt 5, Ch 22, 2.1 General 2.1.2 to Pt 5, Ch 22, 2.1 General 2.1.7* for the propulsion systems, electrical power supply systems and steering systems to demonstrate that a single failure in active equipment or loss of an associated sub-system, see *Pt 5, Ch 22, 1.1 General 1.1.3*, will not cause loss of all propulsion and/or steering capability as required by a class notation. Typical sub-systems include associated control and monitoring arrangements, data communications, power supplies (electrical, hydraulic or pneumatic), fuel, lubricating, cooling, etc.

2.1.2 The FMEA is to be carried out using the format presented in *Table 22.2.1 Failure Mode and Effects Analysis* or an equivalent format that addresses the same safety issues. Analyses in accordance with IEC 60812, *Analysis techniques for system reliability – Procedure for failure mode and effects analysis (FMEA)* or IMO MSC Resolution 36(63) Annex 4 – *Procedures for Failure Mode and Effects Analysis*, would be acceptable.

2.1.3 The FMEA is to be organised in terms of equipment and function. The effects of item failures at a stated level and at higher levels are to be analysed to determine the effects on the system as a whole. Actions for mitigation are to be determined.

2.1.4 The FMEA is to:

- (a) identify the equipment or sub-system, mode of operation and the equipment;
- (b) identify potential failure modes and their causes;
- (c) evaluate the effects on the system of each failure mode;
- (d) identify measures for reducing the risks associated with each failure mode; and
- (e) identify trials and testing necessary to prove conclusions.

2.1.5 At sub-system level it is acceptable, for the purpose of these Rules, to consider failure of equipment items and their functions, e.g. failure of a pump to produce flow or pressure head. It is not required that the failure of components within that pump be analysed. In addition, their failure need only be dealt with as a cause of failure of the pump.

2.1.6 Where FMEA is used for consideration of systems that depend on software-based functions for control or co-ordination, the analysis is to investigate failure of the functions rather than a specific analysis of the software code itself.

Table 22.2.1 Failure Mode and Effects Analysis

Project: Failure Mode and Effects Analysis											
System:				Element:						Sheet No:	
Item No.	Component Description	Function	Mode of Operation	Failure Mode	Failure Cause	Failure Detection	Effect of Failure		Severity	Corrective Action	Remarks
							On Item	On System			

Propulsion and Steering Machinery Redundancy

Part 5, Chapter 22

Section 3

<p>Note The 'severity category' is to be in accordance with the following: (a) Catastrophic; (b) Hazardous; (c) Major; or (d) Minor.</p>											

2.1.7 The FMEA is to establish that in the event of a single failure:

- (a) for **PSMR** and **PSMR** * notations, that the ship will retain not less than 50 per cent of the installed prime mover capacity and not less than 50 per cent of the installed propulsion systems and retain steering capability;
- (b) for **PMR** and **PMR** * notations, that the ship will retain not less than 50 per cent of the installed prime mover capacity and not less than 50 per cent of the installed propulsion systems;
- (c) for **SMR** and **SMR** * notations, that the steering capability remains available;
- (d) for **PSMRL** * notation, that the ship will retain the ability to use available installed prime mover capacity and installed propulsion systems that are not directly affected by the failure and retain steering capability at a service speed of not less than seven knots; and
- (e) for **PMRL** * notation, that the ship will retain the ability to use available installed prime mover capacity and installed propulsion systems that are not directly affected by the failure.

■ Section 3 Machinery arrangements

3.1 Main propulsion machinery

3.1.1 For **PSMR**, **PSMR***, **PMR** and **PMR*** notations, independent main propulsion systems are to be provided so that the ship will retain not less than 50 per cent of the prime mover capacity and not less than 50 per cent of the installed propulsion systems in the event of a single failure of a system or active item of equipment, *see Pt 5, Ch 22, 1.1 General 1.1.3*. In the event of a single failure in equipment, the remaining system(s) is to be capable of maintaining a service speed of not less than seven knots and, for **PSMR** and **PSMR** * notations, give adequate manoeuvring capability, *see Pt 5, Ch 22, 1.2 Plans and information 1.2.4*.

3.1.2 For **PMRL**, **PSMRL**, **PMRL** * and **PSMRL** * notations, independent main propulsion systems are to be provided so that there remains the ability to use the remaining available installed prime mover capacity and installed propulsion systems following a single failure of a system or item of equipment. In the event of a single failure in equipment, the remaining system(s) is to be capable of maintaining a manoeuvring speed and, for **PSMRL** and **PSMRL** * notations, give adequate manoeuvring capability, *see Pt 5, Ch 22, 1.2 Plans and information 1.2.4*.

3.2 Steering machinery

3.2.1 For **PSMR**, **PSMR** * , **SMR** and **SMR** * notations, independent steering systems for manoeuvring the ship are to be installed, such that steering capability will continue to be available in the event of any of the following:

- (a) Single failure in the steering gear equipment.
- (b) Loss of power supply or control system to any steering system.

3.3 Electrical power supply

3.3.1 The main busbars of the switchboard supplying the propulsion machinery and essential services are to be capable of being isolated by a multi-pole linked circuit breaker, disconnector, or switch-disconnector into at least two independent sections.

3.3.2 In the event of the loss of one section or failure of the power supply from one generator, there is to be continuity of sufficient electrical power to supply essential services such that the available installed prime mover capacity and installed propulsion systems will continue to have the ability of functioning at their operational capability where **PSMRL**, **PSMRL** * , **PMRL** and **PMRL** * notations are required. *See Pt 5, Ch 22, 3.2 Steering machinery 3.2.1* for steering machinery requirements.

3.3.3 In the event of the loss of one section or failure of the power supply from one generator, there is to be continuity of sufficient electrical power to supply essential services such that the ship will retain not less than 50 per cent of the prime mover

capacity and not less than 50 per cent of the installed propulsion systems where **PSMR**, **PSMR ***, **PMR** and **PMR *** notations are required. See *Pt 5, Ch 22, 3.2 Steering machinery 3.2.1* for steering machinery requirements.

3.3.4 For ships capable of operating with one service generator connected to the switchboard, arrangements are to be such that a standby generator will automatically start and connect to the switchboard on loss of the service generator. Sequential starting of essential services is to be provided.

3.3.5 For ships operating with two or more generator sets in service connected to the switchboard, arrangements are to be such that, in the event of loss of one generator, the remaining set(s) is to be adequate for the continuity of essential services supplied from that switchboard. This may be achieved by preferential tripping of non-essential services. Alternatively, arrangements can be such that a standby generator will start automatically and connect to the switchboard on loss of one of the generator sets in service.

3.4 Essential services for machinery

3.4.1 Services essential for the operation of the propulsion machinery, steering and the supply of electrical power are to be arranged so to that the ship will retain not less than 50 per cent of the prime mover capacity and 50 per cent of the installed propulsion systems and retain steering capability in the event of a single failure in any of the services, where required by the respective class notations.

3.5 Fuel oil storage and transfer systems

3.5.1 The arrangements for the storage of fuel oil bunkers are to ensure that there is an adequate supply of existing fuel oil on board to allow sufficient time for a shore-based quality analysis of new bunkers, in accordance with ISO 8217 *Petroleum Products – Fuels (Class F) Specification of Marine Fuels* prior to use.

3.5.2 Provision is to be made to enable samples of fuel oil to be taken at the bunkering manifolds.

■ Section 4 Control arrangements

4.1 General

4.1.1 This Section states the requirements for the installation of control, alarm and safety systems but does not signify that machinery spaces may be operated unattended. For unattended machinery space operation, compliance with *Pt 6, Ch 1, 4 Unattended machinery space(s) - UMS notation* is also required.

4.1.2 The control, alarm and safety systems required in *Pt 5, Ch 22, 4.2 Bridge control* are to comply with *Pt 6, Ch 1, 2 Essential features for control, alarm and safety systems*.

4.2 Bridge control

4.2.1 The controls, alarms, instrumentation and safeguards required in *Pt 5, Ch 22, 4.2 Bridge control 4.2.2 to Pt 5, Ch 22, 4.2 Bridge control 4.2.6* are to be provided on the bridge.

4.2.2 For **PSMR**, **PSMR ***, **PMR** and **PMR *** notations, means are to be provided to ensure satisfactory control of propulsion in both the ahead and astern directions when all main propulsion systems are functioning and when one propulsion system is not available.

4.2.3 For **PSMR**, **PSMR ***, **SMR** and **SMR *** notations, means are to be provided to ensure satisfactory control of steering when all steering systems are functioning and when any one steering system is not available.

4.2.4 Where required by *Pt 5, Ch 22, 5.4 Essential services for machinery 5.4.3*, isolation of essential services is to be carried out either automatically or manually from the bridge. Indication of the status of isolation arrangements is to be provided.

4.2.5 Instrumentation to indicate the operational status of running and standby machinery is to be provided for the propulsion systems, the supply of electrical power, steering systems and other essential services.

4.2.6 Alarms are to be provided in the event of:

- (a) A fire in any machinery compartment.

- (b) A high bilge level in any machinery compartment. Irrespective of the assignment of the **UMS** notation, the bilge level detection system and arrangements for automatically pumping bilges, if applicable, are to comply with *Pt 6, Ch 1, 4.6 Bilge level detection*.

■ Section 5 Separate machinery spaces * (star) Enhancement

5.1 General

5.1.1 This Section states the additional requirements where propulsion and steering machinery are installed in separate compartments such that, in the event of the loss of one compartment, the ship will retain availability of propulsion power and manoeuvring capability.

5.1.2 The machinery arrangements, control arrangements and FMEA required by *Pt 5, Ch 22, 2 Failure Mode and Effects Analysis (FMEA)* to *Pt 5, Ch 22, 4 Control arrangements*, together with testing and trials requirements in *Pt 5, Ch 22, 6 Testing and trials*, are to be complied with in addition to *Pt 5, Ch 22, 5.2 Machinery arrangements* to *Pt 5, Ch 22, 5.7 FMEA*.

5.2 Machinery arrangements

5.2.1 The main propulsion machinery is to be arranged in not less than two compartments such that, in the event of the loss of one compartment, propulsion power and/or manoeuvring capability will continue to be available, where required by the respective class notations.

5.2.2 The steering systems are to be arranged in not less than two separate compartments, such that steering capability will continue to be available in the event of the loss of one compartment, where required by the respective class notations.

5.3 Electrical power supply

5.3.1 The generating sets and converting sets required by *Pt 6, Ch 2, 2 Main source of electrical power* are to be arranged so that they are located in at least two separate machinery compartments.

5.3.2 The independent sections of the switchboard required by *Pt 5, Ch 22, 3.3 Electrical power supply 3.3.1* are to be arranged in not less than two separate compartments.

5.3.3 In the event of the loss of one compartment, there is to be continuity of sufficient electrical power to supply essential services, such that propulsion power and steering capability will continue to be available.

5.4 Essential services for machinery

5.4.1 Services essential for the operation of the propulsion machinery, steering and the supply of electrical power are to be arranged, so that propulsion power and steering capability are maintained in the event of the loss of one machinery compartment.

5.4.2 The design of systems which may have a common source, such as those used for supplying fuel oil, lubricating oil, fresh and sea-water cooling, ventilation of compartments and engine starting energy, is to ensure continuous availability of supply in the event of the loss of any one compartment. Where applicable, continuous availability of heating services, fuel oil and water treatments is also to be provided. See *Pt 5, Ch 22, 3.5 Fuel oil storage and transfer systems* and *Pt 5, Ch 22, 5.6 Fuel oil storage for fuel oil storage and transfer systems*.

5.4.3 Where essential services are arranged so that they may supply machinery in another compartment, means of isolation from that compartment is to be provided.

5.4.4 Where pumps for essential services are arranged to supply more than one compartment, standby pumps for the same supplies are to be provided in a different compartment. The standby pumps are to be arranged to start automatically if the discharge pressure from the working pumps falls below a predetermined value.

5.5 Bilge drainage arrangements

5.5.1 The independent power pumps for bilge drainage are to be located in two separate watertight compartments. Each pump is to be capable of draining any compartment. Means of isolation from other compartments is to be provided.

5.5.2 In addition to the independent power pumps installed to comply with *Pt 5, Ch 22, 5.5 Bilge drainage arrangements 5.5.1*, an emergency bilge drainage arrangement is to be provided in each main propulsion machinery space.

5.5.3 Each separate machinery compartment is to be provided with at least one independent power pump direct bilge suction.

5.6 Fuel oil storage

5.6.1 The fuel oil service tanks required by *Pt 5, Ch 14, 4.18 Fuel oil service tanks* are to be located in separate compartments.

5.6.2 Provision is to be made to ensure that fuel oil preparation and transfer arrangements to the fuel oil service tanks are continuously available in the event of the loss of any one compartment, *see also Pt 5, Ch 22, 5.4 Essential services for machinery 5.4.2*.

5.7 FMEA

5.7.1 The FMEA required by *Pt 5, Ch 22, 2.1 General 2.1.1* for the propulsion systems, electrical power supplies, essential services, control systems and steering arrangements is also to address the following:

- (a) Fire in a machinery space or control room.
- (b) Flooding of any watertight compartment which could affect propulsion or steering capability.
- (c) Separation of machinery spaces.

■ Section 6 Testing and trials

6.1 Sea trials

6.1.1 In addition to the requirements for sea trials in *Pt 5, Ch 1, 5.2 Sea trials*, trials are to be carried out to demonstrate that when the ship is operating 50 per cent of the prime mover capacity and 50 per cent of the installed propulsion systems, a speed of not less than 7 knots can be maintained with adequate steering capability, where required by the respective class notations.

6.1.2 Trials are to be carried out to demonstrate the ship's steering capability in accordance with the assessment required by *Pt 5, Ch 22, 1.2 Plans and information 1.2.4* with one steering system out of action.

6.1.3 Where the FMEA report has identified the need to prove the conclusions, testing and trials are to be carried out as necessary to investigate the following:

- (a) The effect of a specific component failure.
- (b) The effectiveness of automatic/manual isolation systems.
- (c) The behaviour of any interlocks that may inhibit operation of essential systems.

6.1.4 During sea trials, the operational envelope(s) is to be determined under the conditions detailed in *Pt 5, Ch 22, 3.1 Main propulsion machinery 3.1.1* and/or *Pt 5, Ch 22, 3.2 Steering machinery 3.2.1*, as required for the class notation.

Section

- 1 **General**
- 2 **Safe return to port**
- 3 **Qualitative failure analysis for propulsion, steering and essential services**
- 4 **Orderly evacuation and abandonment after a casualty**
- 5 **Verification, testing and trials**

■ Section 1 General

1.1 Scope and application

1.1.1 The requirements of this Chapter are additional for passenger ships and are related to machinery and equipment providing services necessary to support safe return to port under the ship's own propulsion in the event of flooding or after a fire and to support orderly evacuation and abandonment in the event of a fire.

1.1.2 The requirements of this Chapter are restricted to machinery and equipment specifically addressed by relevant engineering systems Rules.

1.1.3 The requirements of this Chapter should be read in conjunction with LR's ShipRight Procedure **SRtP**. Where the requirements of this Chapter and ShipRight **SRtP** are complied with, the vessel will be assigned the Descriptive Note **SRtP**.

Note Vessels without the descriptive note should also be appraised using the ShipRight Procedure **SRtP** Appendix 1 and 2 unless otherwise advised.

1.1.4 The performance of machinery and equipment for services referred to in the relevant SOLAS Regulations that are not specifically addressed by relevant engineering systems Rules are not considered (e.g. basic services to safe areas, radiocommunications, navigation systems, etc.). However, these services are to be considered in terms of:

- (a) the supply of electrical power in accordance with SOLAS 1974, as amended; and
- (b) protection provided to machinery and equipment described in *Pt 5, Ch 23, 1.1 Scope and application 1.1.2* (e.g. fire suppression measures in spaces containing propulsion machinery).

1.1.5 For passenger ships having a length of 120 m or more, or having three or more main vertical zones, the requirements of *Pt 5, Ch 23, 1 General to Pt 5, Ch 23, 5 Verification, testing and trials* apply.

1.1.6 For other passenger ships not covered by *Pt 5, Ch 23, 1.1 Scope and application 1.1.5*, the requirements of *Pt 5, Ch 23, 2 Safe return to port* and *Pt 5, Ch 23, 4 Orderly evacuation and abandonment after a casualty* are not applicable. The requirements of Section 3 shall be restricted to the qualitative failure analysis described in *Pt 5, Ch 23, 3.2 Analysis objectives 3.2.2*.

1.1.7 These requirements do not address operational decisions on the actual use of machinery and equipment in the event of flooding or fire (e.g. the use of propulsion and steering in a flooding damage condition).

1.2 Definitions

1.2.1 For the purposes of this Chapter, 'the relevant SOLAS Regulations' refers to SOLAS 1974, as amended:

- (a) Chapter II-1/B-1, *Regulation 8-1 - System capabilities and operational information after a flooding casualty on passenger ships*, ;
- (b) Chapter II-2/G, *Regulation 21 - Casualty threshold, safe return to port and safe areas*, ; and
- (c) Chapter II-2/G, *Regulation 22 - Design criteria for systems to remain operational after a fire casualty*, . *Pt 5, Ch 23, 1.2 Definitions 1.2.1* and *Pt 5, Ch 23, 1.2 Definitions 1.2.1* apply for *Pt 5, Ch 23, 2 Safe return to port* and *Pt 5, Ch 23, 3 Qualitative failure analysis for propulsion, steering and essential services*, *Pt 5, Ch 23, 1.2 Definitions 1.2.1* applies for *Pt 5, Ch 23, 4 Orderly evacuation and abandonment after a casualty*.

Safe Return to Port and Orderly Evacuation and Abandonment in Passenger Ships

Part 5, Chapter 23

Section 1

1.2.2 For the purposes of this Chapter, 'relevant engineering systems Rules' refers to this Part (i.e. *Pt 5 Main and Auxiliary Machinery*), *Pt 6, Ch 1 Control Engineering Systems* and *Pt 6, Ch 2 Electrical Engineering*.

1.2.3 The 'casualty threshold' in the context of a fire includes:

- (a) loss of space of origin up to the nearest 'A' class boundaries, which may be a part of the space of origin, if the space of origin is protected by a fixed fire extinguishing system; or
- (b) loss of the space of origin and adjacent spaces up to the nearest 'A' class boundaries, which are not part of the space of origin.

1.2.4 Ship lengths and main vertical zones considered are to be as defined by *Pt 3, Ch 1, 6.1 Principal particulars 6.1.8* and SOLAS 1974, as amended Chapter II-2/A, *Regulation 3 - Definitions*, respectively.

1.2.5 'Safe areas' are those that will be available, during a ship's return to port under its own propulsion after a casualty that does not exceed the casualty threshold stipulated, to provide the basic services to ensure that the health of passengers and crew is maintained.

1.2.6 For the purposes of this Chapter, 'reversionary control stations' are those control stations provided for use during safe return to port and orderly evacuation and abandonment to satisfy the requirements of *Pt 5, Ch 23, 2 Safe return to port* and *Pt 5, Ch 23, 4 Orderly evacuation and abandonment after a casualty* in the event of the normal control station being subject to fire damage or flooding.

1.2.7 A 'failure' is the termination of the ability of an item to perform a required function. For the purposes of *Pt 5, Ch 23, 3 Qualitative failure analysis for propulsion, steering and essential services*:

- (a) failures result from a fault in a component or system such that it cannot perform an intended or required function, including faults resulting from fire or flooding damage;
- (b) 'common cause failures' are those failures which will cause more than one item to fail simultaneously, or within a sufficiently short period of time as to have the effect of simultaneous failures; and
- (c) 'consequential failures' are secondary failures caused by the effects of a primary failure, i.e. where the occurrence of a failure leads directly to further failures.

1.3 General requirements and risk management

1.3.1 For passenger ships having a length of 120 m or more, or having 3 or more main vertical zones, it is the responsibility of the Shipbuilder to ensure that the arrangement of the ship's machinery and equipment as described in *Pt 5, Ch 23, 1.1 Scope and application 1.1.2* are sufficient for the intended operating modes and to support the provision of the services that the National Administration has determined to be necessary for:

- (a) the ship's safe return to port under its own propulsion, see *Pt 5, Ch 23, 2 Safe return to port*:
 - (i) after a casualty that does not exceed the casualty threshold; or
 - (ii) when the ship is subject to flooding of any single watertight compartment; and/or
- (b) supporting the orderly evacuation and abandonment of the ship if the casualty threshold is exceeded, see *Pt 5, Ch 23, 4 Orderly evacuation and abandonment after a casualty*.

This necessitates activities, which will normally be risk based, to determine the machinery and equipment needed to remain operational for a period of time to satisfy the requirements of the relevant SOLAS Regulations to the satisfaction of the National Administration. These activities are to be carried out prior to the submission of plans in accordance with this Chapter.

1.3.2 The activities referred to in *Pt 5, Ch 23, 1.3 General requirements and risk management 1.3.1* may be conducted at the same time, or in conjunction with, activities to determine the criteria that the National Administration specify as necessary to achieve overall compliance with the relevant SOLAS Regulations. The ship's intended operational routes and/or service restrictions may be considered when establishing criteria.

1.3.3 It is the responsibility of the Shipbuilder to ensure that watertight and fire divisions, fire-fighting systems and bulkhead decks shown on the plans are those approved by the National Administration.

1.3.4 Where alternatives to the requirements of this Chapter are proposed, details demonstrating that the machinery and engineering systems comply with the relevant SOLAS Regulations are to be submitted for consideration.

1.4 Plans and information

1.4.1 In addition to the plans and information otherwise required by relevant engineering systems Rules, the plans and information detailed in *Pt 5, Ch 23, 1.4 Plans and information 1.4.2* are to be submitted.

Safe Return to Port and Orderly Evacuation and Abandonment in Passenger Ships

Part 5, Chapter 23

Section 1

1.4.2 The analysis report described in *Pt 5, Ch 23, 3.1 General 3.1.5* that includes the following information:

- (a) identification of any applicable standards used for analysis of the design;
- (b) description of the analysis team and their roles for information only;
- (c) identification of the objectives of the analysis, including any National Administration acceptance criteria;
- (d) identification of assumptions made in the analysis;
- (e) description of intended system function under normal conditions and in the event of fire or flooding;
- (f) identification of the equipment, system or sub-system and mode of operation, including the design plans and information considered;
- (g) identification of casualty scenarios, probable failure modes and acceptable deviations from the intended or required function;
- (h) evaluation of the local effects and the effects on the overall installation of each failure mode as applicable;
- (i) identification of the worst case scenario in the event of a fire casualty or flooding, as described in *Pt 5, Ch 23, 2.1 General 2.1.1*, and an assessment of the ship's ahead and astern manoeuvring capability under these conditions (IMO Resolution MSC.137(76) - *Standards for Ship Manoeuvrability - (adopted on 4 December 2002)*, provides standards to assess the manoeuvrability of ships); and
- (j) trials, testing and other activities necessary to verify compliance with *Pt 5, Ch 23, 3 Qualitative failure analysis for propulsion, steering and essential services*. The final report described in *Pt 5, Ch 23, 3.1 General 3.1.5* is to be submitted once the proposed design is finalised.

1.4.3 Description of intended system function under normal conditions and in the event of fire or flooding for the services referred to in *Pt 5, Ch 23, 2 Safe return to port* and *Pt 5, Ch 23, 4 Orderly evacuation and abandonment after a casualty*.

1.4.4 Details of analyses conducted to assess the availability of services referred to in *Pt 5, Ch 23, 2 Safe return to port* and *Pt 5, Ch 23, 4 Orderly evacuation and abandonment after a casualty* in the event of fire or flooding.

1.4.5 Details of National Administration criteria (see also *Pt 5, Ch 23, 1.3 General requirements and risk management 1.3.1*), including:

- (a) service speed, manoeuvring capability and time period of operation and ship range for ship return to port under its own propulsion;
- (b) systems determined to be vital to damage control efforts;
- (c) identification of required internal communications arrangements; and
- (d) identification of navigation light circuits to be capable of operation during return to port.

1.4.6 General arrangement plans of the ship showing the location of machinery and equipment, piping systems, cables and controls stations to be employed for:

- (a) each of the services described in *Pt 5, Ch 23, 2.1 General 2.1.2*, *Pt 5, Ch 23, 2.1 General 2.1.3*, and *Pt 5, Ch 23, 4.1 General 4.1.2*; and
- (b) the provision of electrical power described in *Pt 5, Ch 23, 2.1 General 2.1.4* and *Pt 5, Ch 23, 4.1 General 4.1.3*.

The plans are to identify:

- (a) watertight compartments and the bulkhead deck; and
- (b) for passenger ships having a length of 120 m or more or having three or more main vertical zones:
 - (i) safe areas in the context of a casualty; and
 - (ii) casualty threshold 'A' class structural fire protection boundaries.

The plans are to indicate segregation and fire/flooding protection measures and access arrangements for machinery spaces and associated control stations. These plans are also to be made available to the Surveyor on board.

1.4.7 A functional description of the system configurations and intended systems operation in the event of a fire or flooding casualty for the services referred to in *Pt 5, Ch 23, 2 Safe return to port* to *Pt 5, Ch 23, 4 Orderly evacuation and abandonment after a casualty*. This is to include reversionary control stations and required internal communications. A copy is to be provided on board.

1.4.8 Identification and details:

- (a) equipment designed to operate in flooded spaces or under fire conditions; and/or
- (b) other flooding or fire protection measures.

1.4.9 A schedule of normal and emergency operating loads on the electrical system for the different expected operating conditions and services described in *Pt 5, Ch 23, 2 Safe return to port to Pt 5, Ch 23, 4 Orderly evacuation and abandonment after a casualty*.

1.4.10 Details identifying the auxiliary systems required for the operation and control of machinery and equipment to provide the services described in *Pt 5, Ch 23, 2 Safe return to port to Pt 5, Ch 23, 4 Orderly evacuation and abandonment after a casualty*.

1.4.11 Details of time period of operation and ship range and service speed corresponding to fuel storage capacity available in the event of fire or flooding scenarios.

1.4.12 A schedule of activities, including testing and trials, to verify that the ship is capable of providing the services described in *Pt 5, Ch 23, 2 Safe return to port to Pt 5, Ch 23, 4 Orderly evacuation and abandonment after a casualty*.

■ Section 2 Safe return to port

2.1 General

2.1.1 Consistent with the requirements of the relevant SOLAS Regulations, this Section provides design criteria for machinery and equipment described in *Pt 5, Ch 23, 1.1 Scope and application 1.1.2* to remain operational for the ship's safe return to port under its own propulsion, in the event of:

- (a) a fire casualty that does not exceed the casualty threshold; or
- (b) flooding of any single watertight compartment.

2.1.2 When fire damage from a casualty does not exceed the casualty threshold or when the ship is subject to flooding of any single watertight compartment, machinery and equipment essential for the following services are to remain operational in the remaining part of the ship not affected by fire or flooding:

- (a) **propulsion systems and their necessary auxiliaries and control systems.** Propulsion machinery and auxiliary machinery essential for the propulsion of the ship at a service speed and range/distance acceptable to the National Administration for return to port under its own propulsion, see *Pt 5, Ch 23, 3 Qualitative failure analysis for propulsion, steering and essential services*;
- (b) **steering systems and steering-control systems.** Steering systems and steering-control systems sufficient to provide manoeuvring capability acceptable to the National Administration for return to port under its own propulsion, see *Pt 5, Ch 23, 3 Qualitative failure analysis for propulsion, steering and essential services*;
- (c) **systems for transfer and service of fuel oil.** Systems for internal transfer and service of fuel oil capable of fuel supply to active propulsion and power generation equipment;
- (d) **bilge and ballast system.** The bilge pumping systems, and all associated equipment essential for its operation, in all spaces not directly affected by the casualty, see also *Pt 5, Ch 13 Ship Piping Systems* and *Pt 6, Ch 1, 2.7 Valve control systems*;
- (e) **flooding detection systems.** See also *Pt 5, Ch 13, 14 Water ingress detection arrangements*;
- (f) **internal communications.** The means of communication required by:
 - (i) *Pt 5, Ch 1, 4.7 Communications*, *Pt 6, Ch 1, 2.2 Control stations for machinery 2.2.2* and/or *Pt 6, Ch 1, 2.6 Bridge control for main propulsion machinery 2.6.3* between the bridge and machinery main and subsidiary control stations and engineer's accommodation; and
 - (ii) *Pt 5, Ch 19, 2.1 General 2.1.7* between the navigating bridge and the steering gear compartment;
 necessary for operation of machinery and equipment, or otherwise identified by the National Administration to be required, during a ship's return to port under its own propulsion; and
- (g) **navigation lights.** Electric circuit protection, controls and failure alarms for lights specified by the National Administration to be capable of operation, see also *Pt 6, Ch 2, 15.6 Navigation lights*.

2.1.3 In addition to the requirements of *Pt 6, Ch 2, 1.16 Operation under fire conditions* and *Pt 6, Ch 2, 1.17 Operation under flooding conditions*, when fire damage from a casualty does not exceed the casualty threshold or when the ship is subject to flooding of any single watertight compartment, machinery and equipment essential for the following services are to remain operational in the remaining part of the ship not affected by fire or flooding:

(a) for **internal communication**:

- (i) general emergency alarm system. This is in addition to the requirements of *Pt 6, Ch 2, 18.2 General emergency alarm system*;
- (ii) public address system. This is in addition to the requirements of *Pt 6, Ch 2, 18.3 Public address system*; and
- (iii) from the safety centre as required by *Pt 6, Ch 2, 17.10 Safety centre on passenger ships 17.10.2*;

where identified by the National Administration to be required to satisfy the relevant SOLAS Regulations for communication between the bridge, engineering spaces, safety centre, fire-fighting and damage control teams, and for passenger and crew notification and mustering;

(b) for **fire main systems** where supplied by electrically driven fire pumps, the pumps (and electrical equipment essential for their operation) are to be located and arranged such that operating capability will be available in the event of any main vertical zones being directly affected by the casualty. This is in addition to the requirements of *Pt 6, Ch 2, 17.4 Fire pumps*;(c) for **fixed fire-extinguishing systems**:

- (i) for automatic sprinkler systems where supplied by electrically driven pumps, the pumps are to be located and arranged such that operating capability will be available in all spaces not directly affected by the casualty. This is in addition to the requirements of *Pt 6, Ch 2, 17.2 Automatic sprinkler system*;
- (ii) for electrically driven refrigeration units for carbon dioxide fire-extinguishing systems, the units are to be located and arranged such that operating capability will be available in all spaces not directly affected by the casualty. This is in addition to the requirements of *Pt 6, Ch 2, 17.5 Refrigerated liquid carbon dioxide systems*; and
- (iii) electrically operated fire-extinguishing media release alarms in spaces not directly affected by the casualty. This is in addition to the requirements of *Pt 6, Ch 2, 17.9 Fire-extinguishing media release*.

(d) the fire detection and alarm system in all spaces not directly affected by the casualty. This is in addition to the requirements of *Pt 6, Ch 1, 2.8 Fire detection alarm systems* and *Pt 6, Ch 2, 17.1 Fire detection and alarm systems*;(e) power-operated watertight doors in spaces not directly affected by the casualty. This is in addition to the requirements of *Pt 6, Ch 2, 19.1 Watertight doors*;(f) lighting of safe areas and escape route or electrically powered low location lighting. This is in addition to the requirements of *Pt 6, Ch 2 Electrical Engineering, Pt 6, Ch 2, 3 Emergency source of electrical power, Pt 6, Ch 2, 5.4 Insulated distribution systems, Pt 6, Ch 2, 5.7 Lighting circuits, Pt 6, Ch 2, 18.1 Emergency lighting* and *Pt 6, Ch 2, 18.4 Escape route or low location lighting (LLL)*; and

(g) other systems required by relevant engineering systems Rules that the National Administration has determined to be vital to damage control efforts.

2.1.4 When fire damage from a casualty does not exceed the casualty threshold or when the ship is subject to flooding of any single watertight compartment, electrical power, where required, is to be available and sustainable for the following services:

- (a) those required by *Pt 5, Ch 23, 2.1 General 2.1.2*;
- (b) navigational systems, including navigation lights, required by the National Administration to be capable of operation during return to port (see also *Pt 7, Ch 9 Navigational Arrangements and Integrated Bridge Systems* for relevant classification notations);
- (c) internal communication required during a ship's return to port under its own propulsion. Where applicable, charging power for portable means of communication is to be included;
- (d) external communication (for communicating via the GMDSS or the VHF Marine and Air Band distress frequencies even if the main GMDSS equipment is lost);
- (e) fire pumps for the fire main system not directly affected by the casualty;
- (f) fixed fire-extinguishing systems (gaseous and water) designed to protect an entire space in all spaces not directly affected by the casualty;
- (g) fire detection and alarm system in all spaces not directly affected by the casualty;
- (h) power-operated watertight and semi-watertight doors;
- (i) systems and equipment intended to support the provision of services to safe areas;
- (j) other systems that the National Administration has determined to be vital to damage control efforts; and
- (k) other fixed electrically powered loads intended to be operated during return to port.

The electrical power available is to be at least sufficient to supply the machinery and equipment specified by the National Administration as necessary and any additional loads identified in (l) during a ship's return to port under its own propulsion with due regard to such services as may be operated simultaneously.

2.1.5 Auxiliary and support systems (e.g. engine-room ventilation, lighting of spaces outside safe areas not affected by the casualty, etc.) required for the operation and control of machinery and equipment required to operate in accordance *Pt 5, Ch 23, 2.1 General 2.1.2* and *Pt 5, Ch 23, 2.1 General 2.1.3* and to provide electrical power in accordance with *Pt 5, Ch 23, 2.1 General 2.1.4* are to remain operational.

2.1.6 Fuel oil stores, machinery and equipment are to have sufficient capacity to permit the services required by *Pt 5, Ch 23, 2.1 General 2.1.2* to *Pt 5, Ch 23, 2.1 General 2.1.5* to be provided for a time period of operation, ship range/distance and service speed acceptable to the National Administration for the ship's return to port under its own propulsion.

2.1.7 To satisfy *Pt 5, Ch 23, 2.1 General 2.1.2* to *Pt 5, Ch 23, 2.1 General 2.1.6*, machinery and equipment is to be provided, constructed, segregated and arranged such that the services specified may be provided safely and effectively in the event of potential damage to machinery and equipment as a result of a fire that does not exceed the casualty threshold or flooding of any single watertight compartment, including control, safety, alarm and monitoring equipment and control stations.

2.1.8 A description of the intended system function in the event of fire or flooding for the services referred to in this Section are to be submitted for consideration, see *Pt 5, Ch 23, 1.4 Plans and information 1.4.2* and *Pt 5, Ch 23, 1.4 Plans and information 1.4.3*. A risk based analysis is to be conducted in accordance with standards acceptable to LR to assess the availability of services required by this Section (for propulsion and steering, see *Pt 5, Ch 23, 3 Qualitative failure analysis for propulsion, steering and essential services*; for other services, see *Pt 5, Ch 23, 1.4 Plans and information 1.4.4* and *Pt 5, Ch 23, 3.3 Analysis scope 3.3.4*).

■ Section 3 Qualitative failure analysis for propulsion, steering and essential services

3.1 General

3.1.1 A qualitative risk based failure analysis is to be conducted in accordance with this Section to assess compliance with the analysis objectives.

3.1.2 The analysis is to assess the magnitude and consequences of various types of potential hazards in the design that might lead to failure to fulfil the analysis objective(s) stated in *Pt 5, Ch 23, 3.2 Analysis objectives*. The following are to be considered during the analysis:

- (a) analysis facilitation;
- (b) these Rules;
- (c) relevant statutory regulations and National Administration criteria;
- (d) the ship design;
- (e) the intended ship operation; and
- (f) the relevant machinery, equipment and systems.

3.1.3 Those conducting the analysis and their roles are to be recorded in the analysis report.

3.1.4 Requirements specified by the National Administration to satisfy the relevant SOLAS Regulations for the ship's propulsion and steering during return to port, see *Pt 5, Ch 23, 2.1 General 2.1.2*, are to be identified in the analysis report, see also *Pt 5, Ch 23, 1.3 General requirements and risk management 1.3.1*.

3.1.5 The analysis is to be documented, see *Pt 5, Ch 23, 1.4 Plans and information 1.4.2*, and two reports are to be submitted:

- (a) a preliminary analysis, after the initial arrangements of different compartments and propulsion and steering arrangements are known, to permit an assessment of compliance with this Section. This is to include an assessment of propulsion and steering capability in the event of a failure, fire or flooding in any compartment casualty; and then
- (b) a final report on the design, documenting compliance with this Section, that includes a detailed assessment of machinery and equipment required to provide propulsion and steering safely and effectively in accordance with the applicable requirements of *Pt 5, Ch 23, 2.1 General 2.1.2*.

3.2 Analysis objectives

3.2.1 For passenger ships having a length of 120 m or more, or having 3 or more main vertical zones, the analysis is to:

- (a) assess, identify and record the effects of failure in propulsion and steering equipment and systems after a fire casualty or flooding as described in *Pt 5, Ch 23, 2.1 General 2.1.1* and *Pt 5, Ch 23, 2.1 General 2.1.1*; and
- (b) verify compliance with *Pt 5, Ch 23, 2.1 General 2.1.2* and *Pt 5, Ch 23, 2.1 General 2.1.2*.

3.2.2 For other passenger ships, the analysis is to assess, identify and record the effects of failure in propulsion and steering equipment in any space.

3.3 Analysis scope

3.3.1 The analysis is to consider the propulsion and steering machinery, equipment and other associated systems and equipment which might impair the availability of propulsion and steering.

3.3.2 To consider the effects of fire or flooding, the analysis is to address the installed locations of relevant equipment and systems.

3.3.3 The analysis is to include assessment of potential common cause failures and consequential failures when analysing system redundancy intended to maintain propulsion and/or steering in the event of a failure.

3.3.4 Where the analysis scope is extended to additionally consider other services and verify additional compliance with the requirements of *Pt 5, Ch 23, 2 Safe return to port* and/or *Pt 5, Ch 23, 4 Orderly evacuation and abandonment after a casualty*, details may be submitted, see *Pt 5, Ch 23, 1.4 Plans and information 1.4.3* and *Pt 5, Ch 23, 1.4 Plans and information 1.4.4*.

■ Section 4 Orderly evacuation and abandonment after a casualty

4.1 General

4.1.1 Consistent with the requirements of the relevant SOLAS Regulations, this Section provides design criteria for machinery and equipment described in *Pt 5, Ch 23, 1.1 Scope and application 1.1.2* to remain operational, thereby supporting orderly evacuation and abandonment of the ship in the event of a fire that exceeds the casualty threshold.

4.1.2 In addition to the requirements of *Pt 6, Ch 2, 1.16 Operation under fire conditions*, when fire damage from a casualty exceeds the casualty threshold, machinery and equipment essential for the provision of the following emergency services are to remain operational in the remaining part of the ship not affected by fire:

- (a) for **fire main systems** where supplied by electrically driven fire pumps, the pumps (and electrical equipment essential for their operation) are to be located and arranged such that operating capability will be available in all main vertical zones not directly affected by the casualty. This is in addition to the requirements of *Pt 6, Ch 2, 17.4 Fire pumps*;
- (b) for **internal communication**:
- (i) general emergency alarm system. This is in addition to the requirements of *Pt 6, Ch 2, 18.2 General emergency alarm system*;
 - (ii) public address system. This is in addition to the requirements of *Pt 6, Ch 2, 18.3 Public address system*; and
 - (iii) from the safety centre as required by *Pt 6, Ch 2, 17.10 Safety centre on passenger ships 17.10.2*;

where identified by the National Administration to be required to satisfy SOLAS 1974 as amended, Chapter II-2/G, 3 *Systems for communication in support of fire-fighting and/or for passenger and crew notification and evacuation*;

- (c) for **bilge systems**, the bilge pumping systems, and all associated equipment essential for its operation, in all spaces not directly affected by the casualty to permit the removal of fire-fighting water. This is in addition to the requirements of *Pt 5, Ch 13 Ship Piping Systems* and *Pt 6, Ch 1, 2.7 Valve control systems*; and
- (d) lighting of escape routes, assembly stations and at embarkation stations of life-saving appliances and electrically powered low location lighting. This is in addition to the requirements of *Pt 6, Ch 2 Electrical Engineering, Pt 6, Ch 2, 3 Emergency source of electrical power, Pt 6, Ch 2, 5.4 Insulated distribution systems, Pt 6, Ch 2, 5.7 Lighting circuits, Pt 6, Ch 2, 18.1 Emergency lighting* and *Pt 6, Ch 2, 18.4 Escape route or low location lighting (LLL)*.

4.1.3 When fire damage from a casualty exceeds the casualty threshold, electrical power, where required, is to be available and sustainable for the following services:

- (a) those required by *Pt 5, Ch 23, 4.1 General 4.1.2*;
- (b) other required means of internal communications systems not addressed by *Pt 5, Ch 23, 4.1 General 4.1.2*;

- (c) means of external communications provided to communicate via the GMDSS or the VHF Marine and Air Band distress frequencies even if the main GMDSS equipment is lost;
- (d) guidance systems for evacuation not addressed by *Pt 5, Ch 23, 4.1 General 4.1.2*;
- (e) life-saving appliances and arrangements;
- (f) other systems that the National Administration has determined to be necessary to comply with SOLAS 1974 as amended, Chapter II-2/G, 3 *Systems* ; and
- (g) other fixed electrically powered loads intended to be operated during evacuation and abandonment.

The electrical power available is to be at least sufficient to supply the machinery and equipment specified by the National Administration as necessary to support orderly evacuation and abandonment with due regard to such services as may be operated simultaneously.

4.1.4 Machinery and equipment required to satisfy this sub-Section is to be capable of operation for at least 3 hours based on the assumption of no damage outside the unserviceable main vertical zone. System operation within the unserviceable main vertical zones is not required.

4.1.5 A description of the intended system function in the event of fire for the services referred to in this Section is to be submitted for consideration, see *Pt 5, Ch 23, 1.4 Plans and information 1.4.3*. A risk based analysis is to be conducted in accordance with standards acceptable to LR to assess the availability of services required by this Section, see *Pt 5, Ch 23, 1.4 Plans and information 1.4.4* and *Pt 5, Ch 23, 3.3 Analysis scope 3.3.4*.

■ Section 5 Verification, testing and trials

5.1 General

5.1.1 Activities, including testing and trials, are to be carried out to verify that the services described in *Pt 5, Ch 23, 2 Safe return to port* and *Pt 5, Ch 23, 4 Orderly evacuation and abandonment after a casualty* may be provided in the event of fire or flooding to the satisfaction of LR, see *Pt 5, Ch 23, 1.1 Scope and application 1.1.3* and *Pt 5, Ch 23, 1.4 Plans and information 1.4.12*. These activities are to include at least those in *Pt 5, Ch 23, 5.1 General 5.1.2* and *Pt 5, Ch 23, 5.1 General 5.1.3*.

5.1.2 System Capability Testing is to be carried out to verify the ability of each essential system to provide capabilities in line with the design criteria. This testing is to be completed during harbour acceptance trials and sea trials, to the satisfaction of LR.

5.1.3 Scenario testing is to be carried out, verifying the ability of all the essential systems to provide the required capabilities under the identified fire and flooding casualties, taking full account of interaction and dependencies between the essential systems. Tests can be performed during harbour acceptance trials; however, certain scenarios will be required to be tested under sea-going conditions, where performance can only be properly verified during trials at sea (e.g. navigational systems, manoeuvrability, etc.). Testing of at least six scenarios is to be completed and is to include at least:

- (a) loss of a Main Vertical Zone;
- (b) casualty that results in the largest reduction in propulsion power;
- (c) casualty that results in the largest reduction in steering capability;
- (d) casualty that results in the most manual actions;
- (e) casualty with the highest fire risk/load; and
- (f) casualty affecting the greater number of essential systems.

Note It is acceptable that scenarios *Pt 5, Ch 23, 5.1 General 5.1.3*, *Pt 5, Ch 23, 5.1 General 5.1.3*, *Pt 5, Ch 23, 5.1 General 5.1.3*, *Pt 5, Ch 23, 5.1 General 5.1.3* and *Pt 5, Ch 23, 5.1 General 5.1.3* may be covered by the same test if applicable.

5.1.4 The above testing is to verify:

- (a) The effect of a specific component failure.
- (b) The effectiveness of automatic/manual isolation systems.
- (c) The behaviour of any interlocks that may inhibit operation of essential systems.

5.2 Trials

5.2.1 In addition to the requirements for sea trials in *Pt 5, Ch 1, 5.2 Sea trials*, trials are to be carried out to demonstrate that an acceptable service speed and steering capability for return to port can be achieved in the event of fire or flooding, see *Pt 5, Ch 23, 2.1 General 2.1.2, Pt 5, Ch 23, 2.1 General 2.1.2* and *Pt 5, Ch 23, 5.1 General 5.1.3*. The operational envelope(s) under the failure conditions is(are) to be determined.

Section

- 1 **General**
 - 2 **Functional requirements**
 - 3 **Information to be submitted**
 - 4 **Materials**
 - 5 **Hull construction**
 - 6 **Mechanical equipment**
 - 7 **Pumping and piping**
 - 8 **Pressure vessels**
 - 9 **Electrical and control equipment**
-

■ *Section 1*
General

1.1 Scope

1.1.1 The requirements of this Chapter apply to machinery and equipment fitted to combustion machinery in order to reduce emissions produced by the combustion of fuel. Such machinery and equipment is hereinafter referred to as emissions abatement plant.

The requirements are intended to ensure that the emissions abatement plant is safe to operate and maintain and, additionally, where the combustion machinery provides power for essential services, that failure of the emissions abatement plant does not result in an unacceptable loss or degradation of those essential services.

The requirements are applicable to emissions abatement plant making use of both primary techniques, which reduce emissions by controlling the combustion process or removing pollutants prior to combustion, and to secondary emissions abatement techniques which reduce emissions from the exhaust gas after combustion.

It should be noted that these requirements do not provide for the reliability or redundancy necessary to ensure continued operation of the emissions abatement plant, and thereby compliance with relevant emissions requirements, following failure of any machinery, equipment or components associated with the emissions abatement plant.

■ *Section 2*
Functional requirements

2.1 Functional requirements of emissions abatement plant

2.1.1 Emissions abatement plant is to be capable of operating at the maximum output power of the combustion machinery to which it is connected. Where the machinery installation is configured such that it is not intended to operate all the combustion machinery connected to the emissions abatement plant simultaneously in normal operating conditions, this will be subject to special consideration and supported by the submission required by *Pt 5, Ch 24, 3.1 General 3.1.2*. For engines, the maximum power is as stated on the Engine International Air Pollution Prevention Certificate (EIAPPC) or an equivalent certificated engine rating for vessels which are not subject to MARPOL Annex VI - *Regulations for the Prevention of Air Pollution from Ships*.

2.1.2 Operation and maintenance of the emissions abatement plant is not to present a hazard to the ship's occupants or to the environment.

2.1.3 Failure of the emissions abatement plant is not to present a hazard to the ship's occupants or any other hazard other than untreated emissions to the environment.

2.1.4 Where the emissions abatement plant is connected to combustion machinery providing power for essential services, failure of, or the inability to operate, the emissions abatement plant is not to prevent the combustion machinery from delivering sufficient power to those essential services so as to ensure the safe operation of the ship.

2.1.5 Any discharges to water from the emissions abatement plant are to be in accordance with the requirements of National and International Regulations, as applicable.

■ Section 3 Information to be submitted

3.1 General

3.1.1 The information required by this Section, the information required by *Pt 3, Ch 1, 5 Information required and Ch 1 LR IV Information and Plans to be Submitted* of the *Rules and Regulations for the Construction and Classification of Ships for the Carriage of Liquid Chemicals in Bulk, July 2015*, as applicable (hereinafter referred to as the Rules for Ships for Liquid Chemicals).

3.1.2 A description of the emissions abatement plant and the abatement technique(s) used. This is to include details of the proposed combustion machinery operating configurations where using a common emissions abatement system for multiple exhaust gas inlet streams and any limitations on the operation of combustion machinery connected to the emissions abatement system.

3.1.3 Where emissions abatement plant makes use of more than one abatement technique, e.g. separate means for reducing NO_x and SO_x, details demonstrating their compatibility with the combustion machinery and with each other.

3.1.4 Diagram showing the process flows.

3.1.5 Details of the maximum and minimum ambient and sea-water temperatures within which the emissions abatement plant is to operate, and maximum and minimum ambient air temperature and humidity where applicable.

3.1.6 Details of the hazards associated with operation and maintenance and reasonably foreseeable failure of the emissions abatement plant and the means by which they are mitigated.

3.1.7 Details of any fuel treatments, fuel additives or fuel emulsification used as a primary means of emissions abatement from combustion machinery, together with a manufacturer's letter confirming the suitability of combustion machinery to operate with such treatments and additives. Details are to include evidence that materials, fuel filtration and arrangements for the control of viscosity and temperature have been suitably modified, along with evidence of the suitability of fuel pumps and fuel valves for the treated fuel, with particular attention to viscosity, lubricity and stability, as applicable.

3.2 Materials

3.2.1 Details of the materials proposed for all types of construction.

3.3 Chemical substances

3.3.1 Details of the flammability, toxicity, corrosivity and reactivity of any chemicals used, together with details of any exothermic and hazardous reactions, particularly with regard to sea-water.

3.3.2 General arrangement of spaces where toxic or flammable liquids, gases, dusts or vapours are stored or may accumulate, indicating the hatches and other access openings.

3.3.3 Details of arrangements for loading, storage, transfer and disposal of chemicals, by-products or waste products.

3.3.4 General arrangement showing spaces maintained at an over-pressure to prevent the ingress of gases, dusts or vapours.

3.3.5 Details and arrangements of blowdown and bleedoff systems, where applicable, including quantities of chemicals, substances and effluents and the capacity and working pressure of tanks and receivers installed for the reception of such substances and effluents.

3.3.6 Arrangements for purging, gas freeing, inerting or otherwise rendering safe of the emissions abatement plant and storage facilities for chemicals, effluent and by-products associated with the plant.

3.3.7 The flow and return flow of chemicals, substances, effluent or by-products, including:

- (a) Substance supply and product discharge, with details of the arrangements showing the location of shut-off valves and of the control and indicating stations.
- (b) The process plant parameters and analysis of conditions under which emergency shutdown will be initiated.
- (c) Measures to eliminate risk of process fluid reverse flows which could present a risk to propulsion engines, auxiliary engines and essential services.
- (d) The proposed emergency procedures for controlled shutdown of the plant, i.e. depressurising, isolating and the arrangements for the continued operation of the essential services necessary to allow for such controlled shutdown under the emergency conditions identified in *Pt 5, Ch 24, 3.3 Chemical substances 3.3.7*, as applicable.

3.3.8 Proposals for the decontamination of the emissions abatement plant compartments for installations using chemicals, substances and/or producing effluent or byproducts or where there is a possibility of generating hazardous substances during the operation of plant. These proposals are to include both normal operating requirements for decontamination (such as for carrying out maintenance) and post-incident decontamination.

3.3.9 Arrangement for the detection of liquids, gas and vapours where such substances could present a fire, explosion or health hazard.

3.4 Mechanical equipment

3.4.1 Details of mechanical equipment associated with the emissions abatement plant to be installed.

3.4.2 Details of any safety and pressure-relief devices and their discharge arrangements.

3.4.3 Plans showing the materials of construction, working pressures and temperatures, maximum and minimum exhaust gas flows, fuel quality parameters, maximum and minimum flow rates of any water, fluids, chemicals or substances required by the process, maximum effluent or by-product discharge rate resulting from the process.

3.4.4 Details of the arrangements for protecting the emissions abatement plant, its tanks and vessels against temperature, over-pressure and vacuum. Details are to include consideration of storage temperature requirements and, where applicable, tanks are to be maintained within the temperature limits of the chemicals and substances they contain so as to avoid risks of boiling, stress corrosion, freezing and other temperature-sensitive processes.

3.4.5 Details of the by-pass arrangements or, where considered unnecessary, evidence demonstrating that the emissions abatement plant is capable of continued operation with the expected gas flows. Evidence is to include conditions where the emissions abatement plant is in a shutdown condition, both as a result of emergency conditions and when shut down for normal operational reasons. This is to be supported by detailed proposals demonstrating material suitability and is to ensure that, where there is a risk of blockage, this can be monitored so as to ensure that remedial action can be taken before blockage presents a risk to both propulsion and auxiliary engine and emissions abatement plant operations.

3.5 Pressure vessels

3.5.1 Plans of any pressure vessels, including details of the support of the vessels. Diagrammatic plans for systems associated with emissions abatement process equipment as required by *Pt 5, Ch 10 Steam Raising Plant and Associated Pressure Vessels* and *Pt 5, Ch 11 Other Pressure Vessels*, as applicable.

3.5.2 Details of the safety and pressure-relief devices and their discharge arrangements.

3.5.3 Stress calculations taking into account the ship linear and angular accelerations, roll and pitch amplitudes, ship flexure and wind loads, appropriate to any condition which may normally arise at sea.

3.6 Pumping and piping

3.6.1 Plans of the emissions abatement plant piping systems, showing the materials of construction, scantlings, support and expansion arrangements, together with the calculations.

3.6.2 Diagrammatic plans for systems associated with emissions abatement process equipment, as required by *Pt 5, Ch 12 Piping Design Requirements*, *Pt 5, Ch 13 Ship Piping Systems* and *Pt 5, Ch 14 Machinery Piping Systems* and by the Rules for Ships for Liquid Chemicals, as applicable.

3.6.3 Plans showing the arrangement and dimensions of main exhaust pipes, with details of flanges, bolts and weld attachments and particulars of the materials of the pipes, flanges, bolts and welding consumables.

3.6.4 Details of the safety and pressure-relief devices and their discharge arrangements.

3.6.5 Details of air and sounding pipes to tanks containing chemicals, substances and effluent.

3.6.6 The arrangements for the storage on board the ship, and the disposal, of bilge and effluent from the emissions abatement plant spaces, giving particular consideration to the risk of flooding as a result of emissions abatement plant failure. Recognition is to be given to the requirements of the appropriate National Authority.

3.7 Electrical and control equipment

3.7.1 General arrangement plan of the process plant, showing the location of the major items of electrical equipment.

3.7.2 Line diagram of the installation(s), indicating the rating of the various items of rotating machinery, converters and transformers.

3.7.3 Arrangement plans and circuit diagrams of the switchboards.

3.7.4 General arrangement plan of the process plant, showing the location of electrical equipment in hazardous zones.

3.7.5 A schedule of safe-type electrical equipment located in hazardous zones, giving details of the type of equipment employed, the certifying authority and the certificate number.

3.7.6 Line diagrams of any control system(s) fitted.

3.7.7 General arrangement plan of the process plant, showing the locations of items of control equipment and the locations of hazardous zones.

3.7.8 Schedule of the parameters which are monitored and controlled, including alarms and shutdown devices.

■ Section 4 **Materials**

4.1 General

4.1.1 The materials used in the construction of the emissions abatement plant and any associated chemical and effluent storage tanks are to be manufactured and tested in accordance with the requirements of the *Rules for the Manufacture, Testing and Certification of Materials, July 2015* and/or the Rules for Ships for Liquid Chemicals.

■ Section 5 **Hull construction**

5.1 General

5.1.1 The hull structure is to comply with the relevant requirements of *Pt 3 Ship Structures (General)* and *Pt 4 Ship Structures (Ship Types)*, except where stated otherwise in this Section.

5.1.2 All substance and effluent tank structures and their location relative to the ship's hull are to comply with *Ship Survival Capability and Location of Cargo Tanks* and *Cargo Containment* of the Rules for Ships for Liquid Chemicals.

5.1.3 Where necessary, the probable temperature variations during operations and the thermal stress considerations are to be stated. Where it is necessary either to heat or cool chemical storage tanks, the arrangements are to meet the requirements of *Cargo Temperature Control* of the Rules for Ships for Liquid Chemicals.

5.1.4 Where independent tanks are used for chemical substances, these are to be arranged so as to contain spillage. This may be achieved by using a double skinned storage tank, by means of a spill containment bund or by placing the tank in a dedicated compartment. Where a bund is to be used, it is to comply with the following:

- (a) the bund is dimensioned so as to contain the maximum contents of the tank at the angles of inclination required for main and auxiliary machinery in *Table 1.3.2 Inclination of ship* in *Pt 5, Ch 1 General Requirements for the Design and Construction of Machinery*; or

(b) there is a drain arrangement meeting the requirements of *Pt 5, Ch 24, 5.1 General 5.1.6*;

if the tank is located in a dedicated compartment then the compartment is to contain no equipment other than that required by the tank with permanent access and floor plates positioned above the liquid level if the tank were to discharge its full contents into the compartment. Any valves, equipment and emergency stop functions are to be operable from outside this compartment and are to meet the requirements of *Pt 5, Ch 24, 5.2 Location service and control spaces*.

Tanks and spill containment arrangements are to be fitted with alarms and safeguards, in accordance with *Pt 5, Ch 24, 9.1 General 9.1.9*.

5.1.5 Proposals are to be made for the dimensioning of containment arrangements, relative to the potential leakage which may require containment. Where it is not practicable to contain the potential leakage fully and where this leakage can pose a hazard to personnel, proposals are to be submitted, demonstrating that leakage will be transferred to a suitable retention tank, and the means of transfer shall be capable of operating in a dead ship condition and shall be fitted with a flow detection alarm, in accordance with *Pt 5, Ch 24, 9.1 General 9.1.9*.

5.1.6 Tanks are to be arranged such that any residues and slops can be pumped out, drained or otherwise removed from the tank without exposing personnel to these residues and slops.

5.1.7 Chemical tanks containing substances which are categorised as a safety hazard in *Summary of Minimum Requirements* of the Rules for Ships for Liquid Chemicals (designated by letter "S" in column d) are not to be located in the same space as essential machinery and equipment.

5.1.8 Arrangements for venting and gas freeing chemical tanks required by emissions abatement plant are to meet the requirements of *Cargo Tank Venting and Gas-Freeing Arrangements* of the Rules for Ships for Liquid Chemicals.

5.2 Location service and control spaces

5.2.1 Where flammable or toxic chemicals, gases or vapours are present, as identified in *Pt 5, Ch 24, 3.3 Chemical substances 3.3.1* and *Pt 5, Ch 24, 3.3 Chemical substances 3.3.2*, service and control stations essential to the operation of the plant are to meet the requirements of *Pt 5, Ch 24, 9.1 General 9.1.4*, and should, wherever possible, be located so that access thereto is from a defined safe space. If such a location is not possible, the station is to be specially ventilated.

Arrangements are to be made in spaces occupied by emissions abatement plant, in order that substances which are flammable, corrosive, toxic or likely to present a hazard due to reaction when mixed are kept separate unless they are fully contained within a part of the emissions abatement system which has been designed for the safe mixing of such substances.

5.3 Integrity of water and gastightness between compartments

5.3.1 Where integrity of water or gastightness is required between compartments containing the plant, it is to be maintained in way of pipe tunnels or duct keels where these traverse such compartments.

5.3.2 Installations and the spaces in which they are installed are to be, in all cases, compliant with applicable National and International requirements for prevention, detection and extinction of fire.

5.4 Plant support structure

5.4.1 Decks and other structures supporting the plant are, in general, to comply with the requirements of *Pt 3 Ship Structures (General)*. Such structures can, however, be considered on the basis of an agreed uniformly distributed loading in association with local loads at plant support points, provided that adequate transverse strength of the ship is maintained.

5.4.2 Where the nature and dispositions of heavy plant items are such that forces on the ship and support structure due to ship motions are significant (whether underway with or without working fluids, or moored with working fluids), calculations of the loading and the structural response are to be submitted.

5.5 Loading due to wave-induced motions

5.5.1 In cases where the mass distribution of large columnar equipment items is such that the centre of action of the dynamic force differs significantly from the centre of gravity of the item, due account of this is to be taken in the calculation of the forces and moments at the support positions.

5.6 Integrity of weather deck

5.6.1 The integrity of the weather deck is to be maintained. Where items of plant penetrate the weather deck and are intended to constitute the structural barrier to prevent the ingress of water to spaces below the freeboard deck, their structural strength is to be equivalent to the Rule requirements for this purpose. Otherwise, such items are to be enclosed in superstructures or deckhouses fully complying with the Rules.

**■ Section 6
Mechanical equipment****6.1 General**

6.1.1 Emissions abatement plant associated with oil engines, gas turbine and boilers is to comply with the requirements of *Pt 5, Ch 2 Reciprocating Internal Combustion Engines*, *Pt 5, Ch 4 Gas Turbines* and *Pt 5, Ch 10 Steam Raising Plant and Associated Pressure Vessels* respectively, as applicable.

6.1.2 The mounting arrangements for the equipment is to be capable of withstanding the forces and moments stated in *Pt 5, Ch 24, 5.4 Plant support structure* and *Pt 5, Ch 24, 5.5 Loading due to wave-induced motions*.

6.1.3 The design is to take account of the risk of fire or explosion hazards which may arise from deposition of chemicals, unburnt fuel, particulates or any by-products of chemical reactions which may arise during normal operation.

6.1.4 The emissions abatement plant is to be capable of being started in a hot condition without risk of failure due to thermal shock.

6.1.5 Safety or pressure-relief devices are to discharge to a place which will not present a hazard to the ship's occupants or to any machinery.

6.1.6 Where bursting discs or rupture panels are used as safety and pressure-relief devices, these are to be dimensioned and designed in accordance with a recognised National or International Standard.

6.1.7 Where it can be expected that there will be deposition of materials, caking and waste, arrangements are to be provided for the safe cleaning of such systems.

6.1.8 Where there is a possibility of operating conditions in the system falling below the dew point temperature of any gases or vapours present in the system, suitable drains are to be provided to permit the discharge of any condensate formed.

6.2 By-pass or equivalent arrangements

6.2.1 The emissions abatement plant is to be provided with a by-pass capable of transmitting the minimum and maximum exhaust gas flows from the combustion machinery to which it is connected. Where a by-pass is considered unnecessary, the emissions abatement plant is to be capable of safely transmitting the minimum and maximum exhaust gas flows with the emissions abatement plant out of operation, such that the combustion machinery to which it is connected can continue to operate.

6.2.2 Where a by-pass is fitted, there is to be a flow path for exhaust gas at all times.

6.2.3 A means of measuring differential pressure across the emissions abatement plant is to be provided.

6.3 Shared emissions abatement plant

6.3.1 Where emissions abatement plant is connected to more than one engine or source of exhaust gas, valves or equivalent means of isolating the exhaust systems of individual engines from common manifolds are to be provided to prevent reverse flow of exhaust gas into the exhaust manifolds of engines which have been shut down.

6.3.2 Where isolating valves are fitted, a means to verify the effectiveness of the isolation is to be provided.

6.4 Maintenance of back-pressure

6.4.1 The exhaust back-pressure, after installation of emissions abatement plant, is to remain within the allowable limits stated by engine and combustion machinery manufacturers under all expected operating conditions, unless it is intended to operate the system at a negative pressure by means of an induced draught fan.

6.4.2 Where an induced draught fan is fitted to maintain the required exhaust back-pressure, a fan failure is not to prevent the combustion machinery from operating.

6.4.3 Where the emissions abatement plant is fed from multiple exhaust gas inlet streams, the back-pressure is to be maintained within the allowable limits provided by engine machinery manufacturers for all engine or combustion machinery operating configurations.

6.5 Protection of combustion machinery

6.5.1 Measures are to be implemented to ensure that water from the emissions abatement plant cannot flow back into engine turbocharger(s) or other machinery.

6.5.2 Means are to be provided for protecting critical engine components from foreign object damage resulting from failure of, or damage to, the emissions abatement plant. Where such damage is considered unlikely, evidence is to be submitted accordingly.

6.5.3 Where chemicals or substances are injected into the exhaust gas stream before turbocharger(s) or emissions abatement plant are fitted, this is not to present a risk of damage, chemical attack or performance degradation to the turbocharger(s) or engine(s) or machinery with which they are associated.

6.5.4 Where fuel treatments, additives or emulsification are used as a primary means of abating exhaust emissions, machinery is to be compatible with such additives, treatments and emulsified fuel.

6.5.5 Where exhaust gas is re-circulated as a means of emission abatement, the re-circulated exhaust gas is not to cause fouling and corrosion of critical engine components and scavenge air temperature is to be maintained at a level which does not adversely affect engine performance.

6.5.6 Where a wet scrubber is used to clean and cool recirculated exhaust gas, the scrubber is to satisfy the requirements of *Pt 5, Ch 24, 7.1 General 7.1.9*.

■ **Section 7** **Pumping and piping**

7.1 General

7.1.1 Pipe work and transfer systems which may carry chemical substances are to meet the requirements of *Cargo Transfer* of the Rules for Ships for Liquid Chemicals. Lining steel pipe systems with corrosion-resistant materials is subject to special approval. The elasticity of the lining is not to be less than that of the supporting boundary material.

7.1.2 Pipe systems carrying sea-water or fresh water are to meet the requirements of *Pt 5, Ch 12 Piping Design Requirements, Pt 5, Ch 13 Ship Piping Systems* and *Pt 5, Ch 14 Machinery Piping Systems*. Where there is a risk of fresh water or sea-water systems becoming contaminated with process chemicals, substances or effluent, pipe systems are to comply with *Pt 5, Ch 24, 7.1 General 7.1.1*.

7.1.3 Chemical transfer and control arrangements are to meet the requirements of *Ch 1, 5.6 Cargo transfer control systems* of the Rules for Ships for Liquid Chemicals.

7.1.4 Bilge and effluent pumping and piping systems in the emissions abatement plant spaces are to be constructed of material suitable for any chemicals or substances used by the emissions abatement plant, effluent that is produced or any combination of substances on board which might result from accidental admixture.

7.1.5 Arrangements are to be provided for the control of the bilge and effluent pumping and piping system. They are to be installed in the emissions abatement plant spaces from within these spaces and also from a position outside the spaces.

7.1.6 Bilge and effluent pumping and piping systems for hazardous materials should, wherever possible, be installed in the space associated with the particular hazard.

7.1.7 Piping systems carrying chemical substances or effluents and by-products are to meet the requirements of *Materials of Construction and welding* of the Rules for Ships for Liquid Chemicals. This requirement includes exhaust piping where such substances are injected into exhaust gas or where the exhaust gas passes through a liquid scrubber which uses chemical substances.

7.1.8 Where filters are used, they are to be capable of being safely removed for cleaning and replacement safely without interrupting emissions abatement plant or engine operations.

7.1.9 Where scrubbers are used, the following apply:

- (a) Closed loop wet scrubbers are to have natural gravity fall drainage from the wet sump of the scrubber to the process tank or circulating pump suction, with the drain line dimensioned to accommodate 125 per cent of the maximum pumping capacity of the installed water pump(s). No valves are to be fitted to the drain line from the scrubber sump to the process tank unless it can be demonstrated that suitable precautions are in place to prevent the possibility of the scrubber filling with water and reverse-flowing into the engine exhaust duct. Where a valve is fitted to this line, the system is to be protected as for the overboard discharge valve of an open loop system, in accordance with *Pt 5, Ch 24, 9.1 General 9.1.9*.
- (b) For open loop wet scrubbers, the overboard discharge valve and any other sea-water valves downstream of the scrubber are to be protected in accordance with *Pt 5, Ch 24, 9.1 General 9.1.9*. The sea suction valve(s) are also to have position indicators which are to give remote indication of valve position. The scrubber is to be mounted above the waterline under all operating conditions to prevent seawater ingress into the scrubber from the natural flow.
- (c) For wet scrubbing systems (open loop and closed loop), an overflow line is to be fitted to prevent the risk of reverse flow of water to engines, boilers and other machinery. This overflow is to be dimensioned to accommodate 125 per cent of maximum capacity of installed water pumps and is to have no impairment to flow. This overflow line is to be directed to the process tank in closed loop or hybrid installations. On open loop installations, it is to be directed overboard. The overboard discharge is to have an effective means of preventing reverse flow of sea-water. Alternative arrangements to prevent the risk of reverse flow are subject to special consideration.
- (d) Overboard discharge connections from scrubbers are to be positioned below the lowest operating waterline and are to be internally protected from effluent-induced corrosion.

7.1.10 Where applicable, tanks are to be maintained within the temperature limits of the chemicals and substances they contain so as to avoid risks of boiling, stress corrosion, freezing and other temperature-sensitive processes.

■ Section 8 Pressure vessels

8.1 General

8.1.1 Pressure vessels are to be in accordance with the requirements of the relevant Sections of *Pt 5, Ch 10 Steam Raising Plant and Associated Pressure Vessels* or *Pt 5, Ch 11 Other Pressure Vessels* as applicable, or with agreed Codes and specifications normally used for similar plants in land installations, suitably modified and/or adapted for the marine environment.

8.1.2 Mounting arrangements are to take account of forces and moments generated at the supports. Mounting arrangements are to take account of thermal expansion and contraction.

8.1.3 Access is to be provided for inspection, and checking of mountings, fittings, controls and pressure-relief devices.

8.1.4 Arrangements are to allow the pressure settings of pressure-relief devices to be checked.

8.1.5 Where provision is made to isolate pressure-relief devices from pressure vessels for maintenance purposes, at least two such pressure-relief devices are to be fitted.

The isolating or blocking valves are to be arranged such that at least one pressure-relief device remains operational at all times.

■ Section 9 Electrical and control equipment

9.1 General

9.1.1 Electrical system(s) associated with emissions abatement plant are to meet the requirements of *Pt 6, Ch 2 Electrical Engineering*.

9.1.2 Control system(s) associated with the emissions abatement plant are to meet the requirements of *Pt 6, Ch 1 Control Engineering Systems*.

9.1.3 Electrical and control equipment associated with the emissions abatement plant is to be compatible with any chemicals used and meet the requirements of *Chapter 10* of the Rules for Ships for Liquid Chemicals.

9.1.4 Where flammable or toxic chemicals, gases or vapours are present, as identified in *Pt 5, Ch 24, 3.3 Chemical substances 3.3.1* and *Pt 5, Ch 24, 3.3 Chemical substances 3.3.2*, or where there is a possibility that flammable gases and vapours can be produced as a result of deviations from normal operation, the defining of hazardous zones is to be in accordance with *Pt 6, Ch 2, 14 Electrical equipment for use in explosive gas atmospheres or in the presence of combustible dusts*.

As a minimum, for the detection of gas and vapours, a gas detection system is to be fitted which is to activate at a concentration corresponding to the substance safe occupational level. The locations of the detectors are to be determined relative to the layouts of the individual spaces and are to be indicated on the plan submission required by *Pt 5, Ch 24, 3.3 Chemical substances 3.3.9*. Where it is not practicable to install a detection system where gas detection equipment is not appropriate, e.g. for substances not emitting gases or vapours, alternative proposals are to be submitted to ensure the safety of persons from exposure to such substances.

9.1.5 Process tanks which form part of the operating loop of any emissions abatement equipment are to have a high level alarm, in accordance with *Table 24.9.1 Machinery emissions to air abatement plant: alarms and safeguards*. Effluent tanks which are not part of the normal process loop and which are used for storage of effluent or substances prior to discharge from the vessel are to be protected, in accordance with *Table 24.9.1 Machinery emissions to air abatement plant: alarms and safeguards*.

Tank alarm and trip sensors are to be positioned at a point which will allow the system shutdown to operate before the tank overflows, based on the maximum design flow rates and shut-down response time. Where a low level is identified as presenting a risk to crew or machinery, tanks are to have a low level alarm and a low level trip. These are to be positioned so as to operate before a low level results in a hazardous condition, based on system design flow rates and a system shut-down response time.

9.1.6 An emergency stop function is to be provided, which is to:

- Close quick-closing valves on chemical tank(s) (where applicable).
- Stop chemical feed pump(s) (where applicable).
- Where fitted, open exhaust gas cleaning by-pass valve.
- Stop scrubber water pumps and close scrubber water inlet valve (where applicable).

9.1.7 The emergency stop function is to be capable of being actuated from the machinery control room, the navigating bridge and from within compartments containing exhaust gas cleaning plant. In order to mitigate the risk of chemical release, spaces containing chemical storage tanks or chemical pumping equipment are to have an emergency stop which is to shut down the chemical supply to the emissions abatement plant. Other parts of the emissions abatement plant such as wash water pumps need only be stopped by this emergency stop where loss of chemical injection could result in further risks arising from operating the plant without chemical injection. This is to form part of the submission required in *Pt 5, Ch 24, 3.1 General 3.1.6*.

9.1.8 Alarms and safeguards are to be provided for the critical system parameters in order to avoid danger to crew and machinery. As a minimum, the alarms and safeguards listed in *Table 24.9.1 Machinery emissions to air abatement plant: alarms and safeguards* are to be fitted. Where these Rules require alarms and also trip protection to be fitted, the alarm and trip are to be independent of each other.

9.1.9 Where emissions abatement plant makes use of chemical substances, a means of monitoring abnormal flows of such chemicals is to be provided.

Table 24.9.1 Machinery emissions to air abatement plant: alarms and safeguards

Item	Alarm	Note
Exhaust gas outlet temperature	High	
Exhaust gas inlet temperature	High	
Exhaust gas inlet temperature	Low	Only for selective catalytic reduction
Differential pressure across abatement plant unit	High	
Abatement plant by-pass valve in exhaust duct	Valve movement	See Note 1
Machinery exhaust duct isolating valve	Valve movement	See Note 2
Wet emissions abatement unit overboard discharge valve	Closed	Emissions abatement plant is to be shut down automatically, see Note 6
Wet emissions abatement unit overflow line flow detection	Flow present	Emissions abatement plant is to be shut down automatically, see Note 6
Wet emissions abatement water pressure	Low	
Wet emissions abatement unit water level	1st Stage high	
Wet emissions abatement unit water level	2nd Stage high	Emissions abatement plant is to be shut down automatically, see Note 6
Chemical feed flow	High	Chemical feed pump is to be shut down automatically
Chemical feed flow	1st Stage low	
Chemical feed flow	2nd Stage low	Chemical feed pump is to be shut down automatically
Process tank level	1st Stage high	See Note 3
Process tank level	2nd Stage high	Emissions abatement plant is to be shut down automatically, see Note 3
Chemical storage tank level	1st Stage high	
Chemical storage tank level	2nd Stage high	
Chemical storage tank level	Low	
Chemical storage tank temperature	High	See Note 4
Chemical storage tank temperature	Low	See Note 4
Chemical tank containment bund level	High	Tank outlet quick closing valve is to close automatically, see Note 5
Chemical tank containment drain line flow detection	Flow present	Tank outlet quick closing valve is to close automatically, see Note 5
Exhaust gas recirculating fan failure	Failure	
Recirculating exhaust gas temperature return to engine	High	

Emissions Abatement Plant for Combustion Machinery

Part 5, Chapter 24 Section 9

Induced draught fan failure	Failure	Where fitted
<p>Note 1. Only where a by-pass valve is fitted, see <i>Pt 5, Ch 24, 3.3 Chemical substances 3.3.5</i>. This valve shall open to the by-pass position as part of the unit shutdown logic.</p> <p>Note 2. Only where fitted, see <i>Pt 5, Ch 24, 5.1 General</i>.</p> <p>Note 3. The process tank is any tank forming part of a wet abatement system flow loop or effluent tanks which receive bleed-off from the main flow loop, or such tanks not forming part of the system flow loop but which are essential for operation of the system, including those on exhaust gas recirculating installations, see <i>Pt 5, Ch 24, 7.1 General 7.1.9</i>. Where low level can present a hazard, process tanks are also to have low level protection.</p> <p>Note 4. Where chemical substances are to be kept within a defined temperature range, alarms will be fitted, based on the allowable temperature range, see <i>Pt 5, Ch 24, 5.1 General 5.1.2</i> and <i>Pt 5, Ch 24, 7.1 General 7.1.10</i>.</p> <p>Note 5. Chemical spillage detection alarm will depend on the means of spill containment fitted, see <i>Pt 5, Ch 24, 5.1 General 5.1.2</i>.</p> <p>Note 6. Wet emissions abatement unit shall include such systems fitted as part of the exhaust gas recirculating installations.</p>		

Ballast Water Treatment System and Installation

Part 5, Chapter 25

Section 1

Section

- 1 **General**
- 2 **Functional requirements**
- 3 **Performance requirements**
- 4 **Documentation required for appraisal**
- 5 **Materials**
- 6 **Risk-based studies**
- 7 **Piping systems**
- 8 **Mechanical equipment and components**
- 9 **Electrotechnical Systems**
- 10 **Structural and Space categorisation requirements**
- 11 **System arrangement requirements**
- 12 **Fire safety requirements**

■ Section 1 General

1.1 Purpose and Scope

1.1.1 The purpose of this Chapter is to provide Rule requirements for machinery and equipment used to prevent transfer of harmful aquatic organisms and pathogens within ballast water and sediment. Such machinery and associated equipment is hereinafter referred to as the Ballast Water Treatment System (BWTS).

1.1.2 The Rules are intended to ensure that the design, construction and installation of the BWTS achieve a level of safety which is acceptable to Lloyd's Register (LR) and, additionally, to ensure that a failure of the BWTS will not affect the operation of essential ship systems.

1.1.3 These requirements do not address the environmental performance of the BWTS, which is subject to the national and international statutory requirements. Operators are responsible for ensuring compliance with the relevant ballast water discharge standards and sediment controls.

1.1.4 Where risk-based studies identify further risk mitigation measures in addition to the specific requirements in the Rules then such measures are to be implemented.

1.2 Definitions

1.2.1 Where any of the terms contained within this Section are used within this Chapter, their meaning is to be as defined in *Pt 5, Ch 25, 1.2 Definitions 1.2.2 to Pt 5, Ch 25, 1.2 Definitions 1.2.16*

1.2.2 **Area** - area means a defined location on board the ship. An area can be on open deck. An area can be open, semi-enclosed or enclosed. An area can be a space below deck. An area can be hazardous or non-hazardous.

1.2.3 **Ballast Water Treatment System** – is the arrangement in place for the purpose of treating ballast water, collecting samples, and analysing discharge (if fitted). It includes piping and fittings, equipment, treatment techniques and an electrical and control system.

1.2.4 **Concentrated treatment** – is the accumulation of treatment medium or its by-product (e.g. chemicals, other reactive materials, dissolved gases, etc.).

- 1.2.5 **Hazardous material** – a substance, in the form of liquid, solid or gaseous state, solely or in combination with other material, which promotes danger to environment or human life.
- 1.2.6 **Hazardous area** - as defined in *Pt 6, Ch 2, 14.5 Hazardous zones and spaces*.
- 1.2.7 **Reactive material** – a substance, used in ballast water treatment, which has potential for rapid oxidation or for undergoing a chemical reaction when in contact with other substances.
- 1.2.8 **Risk** - the combination of the likelihood of a potentially dangerous event and its consequence. Likelihood may be expressed as a probability or a frequency.
- 1.2.9 **Risk assessment**- is the evaluation of likelihood and consequence, together with a judgement on the significance of the result. See IEC/ISO 31010: *Risk management, risk assessment techniques*.
- 1.2.10 **Side stream piping arrangement** – is an arrangement in place to use a portion of ballast water from main ballast line or sea water from other sources (typically less than 10 per cent of ballast line capacity). The purpose for this arrangement is to produce a concentrated treatment (see *Pt 5, Ch 25, 1.2 Definitions 1.2.4*) that is then applied to the rest of the ballast capacity.
- 1.2.11 **Accommodation spaces** - are those spaces used for public spaces, corridors, lavatories, cabins, offices, hospitals, cinemas, game and hobby rooms, barber shops, pantries containing no cooking appliances and similar spaces.
- 1.2.12 **Cargo area** - is that part of the ship that contains cargo holds, cargo tanks, slop tanks and cargo pump-rooms including pump-rooms, cofferdams, ballast and void spaces adjacent to cargo tanks and also deck areas throughout the entire length and breadth of the part of the ship over the above-mentioned spaces.
- 1.2.13 **Machinery spaces of category A** - are those spaces and trunks to such spaces which contain either:
- internal combustion machinery used for main propulsion;
 - internal combustion machinery used for purposes other than main propulsion where such machinery has in the aggregate a total power output of not less than 375 kW; or
 - any oil-fired boiler or fuel oil unit, or any oil-fired equipment other than boilers, such as inert gas generators, incinerators, etc.
- 1.2.14 **Other machinery spaces** - are spaces containing propulsion machinery, boilers, fuel oil units, steam and internal combustion engines, generators and major electrical machinery, oil filling stations, refrigerating, stabilizing, ventilation and air conditioning machinery, and similar spaces, and trunks to such spaces.
- 1.2.15 **Service spaces** - are those spaces used for galleys, pantries containing cooking appliances, lockers, mail and specie rooms, store rooms, workshops other than those forming part of the machinery spaces, and similar spaces and trunks to such spaces.
- 1.2.16 **Special category spaces** - are those enclosed vehicle spaces above and below the bulkhead deck, into and from which vehicles can be driven and to which passengers have access. Special category spaces may be accommodated on more than one deck provided that the total overall clear height for vehicles does not exceed 10 m.

■ Section 2

Functional requirements

2.1 General

- 2.1.1 Failure of the Ballast Water Treatment System (BWTS) is not to impair or restrict ballasting or de-ballasting operations.
- 2.1.2 Failure of the BWTS is not to impair essential systems as defined by, but not limited to, *Pt 6, Ch 2, 1.6 Definitions*.
- 2.1.3 The BWTS is not to present a hazard to the personnel, the ship or the environment during normal operation or in the event of foreseeable failure.

■ Section 3 Performance requirements

3.1 General

- 3.1.1 The Ballast Water Treatment System is to be able to treat the ballast capacity of the vessel. Where specific requirements or conditions are to be maintained for the effectiveness of BWTS, the safety of the ship is not to be compromised.
- 3.1.2 Ballast water system pressure drop due to the BWTS is to be compensated, as required, to ensure that operation of the ballast water system is not compromised.
- 3.1.3 Where the BWTS, or its associated equipment, is in use for purposes other than that required by *Pt 5, Ch 25, 1.1 Purpose and Scope 1.1.1*, means should be provided to ensure that the BWTS is readily available for the primary purpose of treating ballast water.
- 3.1.4 The BWTS arrangement, including treatment units, filtration units, electrical and control units, sampling arrangements, neutralising units with associated piping and fittings, structural arrangements and hazardous area classification, where applicable, shall be subjected to appraisal and be acceptable to LR.
- 3.1.5 By-pass and isolation arrangements are to be provided for BWTS as required in *Pt 5, Ch 25, 11.3 By-pass and isolation arrangement*.
- 3.1.6 The design of BWTS equipment is to minimise the risk of fire, overheating, explosion and asphyxiation hazards arising from the use and/or production of chemicals and other substances. See *Pt 5, Ch 25, 9.1 General 9.1.6*.
- 3.1.7 The build-up of hazardous material in ballast pipes and in ballast tanks is to be prevented.
- 3.1.8 Ballast tank coatings are not to be affected by the prolonged exposure to any hazardous materials that may be released into the ballast water.

■ Section 4 Documentation required for appraisal

4.1 Ballast Water Treatment System appraisals

- 4.1.1 The documents listed in *Pt 5, Ch 25, 4.1 Ballast Water Treatment System appraisals 4.1.2* to *Pt 5, Ch 25, 4.1 Ballast Water Treatment System appraisals 4.1.9* are to be submitted for appraisal of the ballast water treatment system (BWTS).
- 4.1.2 A description of the BWTS and the treatment technique(s) used. This is to include the proposed treatment unit configurations, method of integration with the ship's ballast system and specific requirements for ancillary systems.
- 4.1.3 Functional description of the BWTS including the system operational concept and system description details.
- 4.1.4 Process Flow Diagram (PFD) of the BWTS.
- 4.1.5 Material specification for all items used in the construction of the BWTS including temperature and pressure ratings.
- 4.1.6 Details of flammability, toxicity and reactivity of chemicals to be made available along with the instructions for storage, handling and fire-fighting.
- 4.1.7 Arrangement plans and circuit diagrams of the switchboards and line diagrams of any control and safety system(s) fitted.
- 4.1.8 Report of risk-based studies, see *Pt 5, Ch 25, 6.2 Risk assessment of BWTS*
- 4.1.9 Documents, plans and information, as listed in the following Rules, are to be submitted:
- (a) For control systems:
- (i) Details of control, alarm and safety systems as required by *Pt 6, Ch 1, 1.2 Documentation required for design review 1.2.2*

Ballast Water Treatment System and Installation

Part 5, Chapter 25

Section 4

- (ii) Details of programmable electronic systems as required by *Pt 6, Ch 1, 1.2 Documentation required for design review 1.2.5*
- (iii) Plans showing the details and location of control stations as required by *Pt 6, Ch 1, 1.2 Documentation required for design review 1.2.7*
- (iv) Details of instrumentation and control cabling as required by *Pt 6, Ch 1, 1.2 Documentation required for design review 1.2.9*
- (b) For BWTS which are to be installed in hazardous areas:
 - (i) Details, plans and arrangements required by *Pt 6, Ch 2, 14 Electrical equipment for use in explosive gas atmospheres or in the presence of combustible dusts*
 - (ii) A schedule of equipment for use in explosive atmospheres as required by *Pt 6, Ch 2, 1.2 Documentation required for design review 1.2.9*
- (c) Type Approval Certification where required by the LR Rules, see *Pt 6, Ch 1, 2 Essential features for control, alarm and safety systems*.

4.2 Ballast Water Treatment System ship specific installation appraisal

4.2.1 The documents listed in *Pt 5, Ch 25, 4.2 Ballast Water Treatment System ship specific installation appraisal 4.2.2 to Pt 5, Ch 25, 4.2 Ballast Water Treatment System ship specific installation appraisal 4.2.11* are to be submitted for appraisal of the installation of a ballast water treatment system (BWTS) on board an LR classed ship, in addition to details of the BWTS required by *Pt 5, Ch 25, 4.1 Ballast Water Treatment System appraisals 4.1.3, Pt 5, Ch 25, 4.1 Ballast Water Treatment System appraisals 4.1.6 and Pt 5, Ch 25, 4.1 Ballast Water Treatment System appraisals 4.1.9*

4.2.2 Piping and Instrumentation Diagram (P&ID) of the ballast system, showing the proposed integration with the BWTS and ancillary systems connected to the BWTS, including cross-connections.

4.2.3 For retrofit installations, in addition to *Pt 5, Ch 25, 4.2 Ballast Water Treatment System ship specific installation appraisal 4.2.2*, existing ballast system's P&IDs are to be submitted along with details of any modifications required, such as cross-connection, tank construction, air vent, overflow lines, hull penetration, etc.

4.2.4 Material specification, temperature and pressure ratings of piping, valves and fittings used to integrate treatment unit(s) and associated equipment into the ballast system.

4.2.5 Details of by-pass arrangement or, where a by-pass arrangement is not fitted, evidence demonstrating the ability of the ship's ballast system to continue in operation at full capacity regardless of the BWTS's condition.

4.2.6 General arrangement of the ship showing layout of the BWTS installation, including major items of electrical equipment.

4.2.7 A copy of risk-based study report conducted for the BWTS, see *Pt 5, Ch 25, 4.1 Ballast Water Treatment System appraisals 4.1.8*.

4.2.8 Schedule of mechanical equipment to be located in hazardous area.

4.2.9 Details of electrical equipment and hazardous area installation as listed in the following Rules respectively:

(a) Details and arrangements of electrical equipment required by *Pt 6, Ch 2, 1.2 Documentation required for design review 1.2.2, Pt 6, Ch 2, 1.2 Documentation required for design review 1.2.2, Pt 6, Ch 2, 1.2 Documentation required for design review 1.2.2, Pt 6, Ch 2, 1.2 Documentation required for design review 1.2.2, Pt 6, Ch 2, 1.2 Documentation required for design review 1.2.2 and Pt 6, Ch 2, 1.2 Documentation required for design review 1.2.2*

(b) Details of the location and arrangement of hazardous area zones as required by *Pt 6, Ch 2, 1.2 Documentation required for design review 1.2.8*.

4.2.10 Fire detection, extinction and suppression arrangements of compartment(s) where the BWTS and associated chemicals are stored/in use, as applicable. This is to include specific extinguishing requirements and compatibility with materials/chemicals used.

4.2.11 In addition to the above, for a BWTS meant to be installed in tankers or a BWTS which generates or uses hazardous material, the following plans are required to be submitted:

(a) Ventilation system plans, including airlocks, pipe penetrations and general construction details, if the BWTS is meant to be placed in a dedicated room, see *Pt 5, Ch 25, 10.4 BWTS space categorisation requirements*. The ship's plans are to indicate hazardous area configuration, if any.

(b) Plans for ventilation system and electrical and mechanical equipment ratings are to be submitted if the BWTS is meant to be placed in the cargo pump room.

- (c) A water tightness test report is to be submitted for the equipment which is to be used in a submerged or semi-submerged condition.
-

■ Section 5 Materials

5.1 General

5.1.1 Material used for the Ballast Water Treatment System (BWTS) is to be manufactured and tested in accordance with the requirement of the *Rules for the Manufacture, Testing and Certification of Materials*.

5.1.2 Where the BWTS uses hazardous or reactive materials then the proposed materials for construction are to be suitable for their intended use. Such materials are subject to special consideration and are to be considered in the risk-based studies, see *Pt 5, Ch 25, 6 Risk-based studies*.

5.1.3 Materials for construction of chemical storage tanks and associated piping systems are to be in accordance with the *Rules and Regulations for the Construction and Classification of Ships for the Carriage of Liquid Chemicals in Bulk* (hereinafter referred to as the Rules for Ships for Liquid Chemicals), as applicable.

■ Section 6 Risk-based studies

6.1 Purpose

6.1.1 The purpose of the risk-based studies is to:

- (a) Evaluate the safety of the BWTS.
- (b) Evaluate the safety of the integration of the BWTS with the ballast system and other ship's systems.
- (c) Specially consider system designs which deviate from the requirements of LR Rules.

6.1.2 The risk-based studies are to be undertaken in accordance with LR's ShipRight procedure, *Assessment of Risk Based Design* and associated annexes.

6.1.3 The risk-based studies are to be undertaken to an acceptable industry or international standard (e.g. ISO 31010 *Risk management – Risk assessment techniques*), see *Pt 5, Ch 25, 6.2 Risk assessment of BWTS 6.2.1*.

6.1.4 Risk-based studies for ship specific installation are required (see *Pt 5, Ch 25, 6.3 Risk assessment of BWTS installation*),

- (a) if the system arrangement deviates from the requirements for installation of this Chapter, or
- (b) if the Risk assessment of the BWTS, see *Pt 5, Ch 25, 6.2 Risk assessment of BWTS*, identifies a need for further studies at the installation phase.

6.2 Risk assessment of BWTS

6.2.1 The risk assessment is to identify the hazards associated with operation and maintenance of the BWTS under all normal and reasonably foreseeable abnormal conditions including but not limited to system integrity, leakage scenarios and accumulation of hazardous materials.

6.2.2 The risk assessment is to consider any risk of scaling the BWTS to suit the different treatment capacities. It is to consider, but not be limited to, the effects of treatment techniques, by-products and neutralisation methods, as applicable.

6.2.3 The risk assessment is to consider risks, in general, which may occur when integrating the BWTS into the ship's ballast water system and associated systems as outlined in *Pt 5, Ch 25, 6.3 Risk assessment of BWTS installation 6.3.2*.

6.2.4 The risk assessment is to demonstrate that an appropriate level of safety is achieved; the risk acceptability criteria are to be defined by the risk-based study and are to be acceptable to LR.

6.2.5 A risk assessment may identify further safety measures in addition to those specifically stated in the Rules.

6.3 Risk assessment of BWTS installation

6.3.1 The risk assessment is to identify hazards associated with operation and maintenance of the BWTS in a ship specific environment, under all normal and reasonably foreseeable abnormal conditions. See *Pt 5, Ch 25, 6.2 Risk assessment of BWTS 6.2.1, Pt 5, Ch 25, 6.2 Risk assessment of BWTS 6.2.2 and Pt 5, Ch 25, 6.2 Risk assessment of BWTS 6.2.3.*

6.3.2 The risk assessment is to focus on, but not be limited to, risks which may affect safety of persons and the reliable operation of essential ship systems associated with operation of the BWTS under all normal and abnormal conditions. As a minimum the following are to be considered:

- effects on ballast tank coatings;
- effects on existing piping, fittings and valves;
- hazardous area classification;
- structural strength and integrity of hull;
- fail-safe condition, location and arrangement of isolation valves;
- accumulation of flammable or toxic gases;
- storage and handling of chemicals or reactive materials.

6.3.3 The risk assessment is to demonstrate that an appropriate level of safety is achieved and that the reliability of essential services is improved or remains unchanged. For risk acceptability criteria, see *Pt 5, Ch 25, 6.2 Risk assessment of BWTS 6.2.4.*

6.3.4 The risk assessment may identify further safety measures in addition to those specifically stated in the Rules.

6.4 Assessment of alternative BWTS designs

6.4.1 Alternative BWTS designs which deviate from these Rules are subject to special consideration and may be accepted by LR where supported by a risk assessment which demonstrates an equivalent level of safety to that which would be achieved by application of these Rules.

6.4.2 The risk assessment is to include an analysis of the BWTS as indicated in *Pt 5, Ch 25, 6.2 Risk assessment of BWTS and Pt 5, Ch 25, 6.3 Risk assessment of BWTS installation*, as applicable.

6.4.3 The risk assessment may identify the requirement for safety measures in addition to those specifically stated in the Rules.

■ Section 7 Piping systems

7.1 General

7.1.1 Manufacturing, testing and integration of piping and fittings are to be in accordance with the *Rules and Regulations for the Classification of Ships*, *Pt 5, Ch 12 Piping Design Requirements*, *Pt 5, Ch 13 Ship Piping Systems*, *Pt 5, Ch 14 Machinery Piping Systems* and *Pt 5, Ch 15 Piping Systems for Oil Tankers*.

7.1.2 Piping systems which carry chemical substances are to meet the requirements of *Ch 5* of the Rules for Ships for Liquid Chemicals. Use of non-metallic materials will require special consideration.

7.1.3 Piping systems which carry sea water or fresh water are to meet the requirements as per *Pt 5, Ch 25, 7.1 General 7.1.1*. Where there is a risk of a water system becoming contaminated with hazardous materials (e.g. process chemicals, reactive materials or by-products), piping systems are to comply with *Pt 5, Ch 25, 7.1 General 7.1.2* as applicable.

7.1.4 Piping systems utilising plastic pipes are to meet the requirements of *Table 12.5.3 Fire endurance requirements* in *Pt 5, Ch 12 Piping Design Requirements*.

7.1.5 Piping systems utilised for handling active/reactive materials are to be separate and distinct from each other and the ship's piping systems.

7.2 Side stream piping

7.2.1 Side stream piping is to meet the requirements of *Pt 5, Ch 25, 7.1 General* and the piping which carries concentrated treatment is also to meet the requirements of *Pt 5, Ch 25, 7.2 Side stream piping 7.2.2 to Pt 5, Ch 25, 7.2 Side stream piping 7.2.4*.

7.2.2 Material for side stream piping is to be non-reactive with the water properties and substances used in the system.

7.2.3 Side stream piping is to be designed to minimise pipe length and number of connections. Alternatively it is to be demonstrated that risk of leakage is limited and the formation of toxic or flammable atmosphere is prevented.

7.2.4 Side stream piping is to be protected against mechanical damage.

■ Section 8 Mechanical equipment and components

8.1 General

8.1.1 Air, sounding and overflow arrangement associated with BWTS are to comply with the requirement of *Pt 5, Ch 13, 11 Ballast system* and *Pt 5, Ch 13, 12 Air, overflow and sounding pipes* respectively.

8.1.2 Modification to ballast tank, air and overflow system, air pipe closing appliances and other systems and equipment is subject to special approval, see *Pt 5, Ch 25, 10 Structural and Space categorisation requirements*.

8.1.3 Chemical injection lines, concentrated treatment injection lines, inert gas injection lines and sampling point are to be of a rigid construction and be properly supported.

8.1.4 De-gassing equipment is to demonstrate that the risk of leakage is prevented. Vent arrangements are to be directed to a safe location on open deck. A safe location is a location that in the absence of a vent would be non-hazardous. Hazardous area classification is to be conducted for the area surrounding the openings of such vents.

8.2 Filtering units

8.2.1 Filters to be sized to the maximum flow rate of the ballast system.

8.2.2 Filters arranged in line with the ballast system are to be provided with redundancy.

8.2.3 Filter casings are to satisfy the requirements of *Pt 5, Ch 11 Other Pressure Vessels*, as applicable, see also *Pt 5, Ch 25, 5.1 General 5.1.1*.

8.2.4 Where filters are provided with by-pass arrangement as per *Pt 5, Ch 25, 11.3 By-pass and isolation arrangement*, above requirements *Pt 5, Ch 25, 8.2 Filtering units 8.2.2* and *Pt 5, Ch 25, 8.2 Filtering units 8.2.3* may be exempted.

8.3 Other components

8.3.1 Inert gas systems are to meet the technical requirements of *Pt 5, Ch 15, 7 Inert gas systems on Tankers of 8,000 tonnes DWT and above*, as applicable.

8.3.2 Ozone generators, electro chlorination units, electrolysis units, oxygen generators, electro-dialytic units, ultraviolet units, ultrasonic units, coagulation units, other treatment units and ancillaries are to be constructed to recognised industrial, National or International Standards acceptable to LR.

■ Section 9 Electrotechnical Systems

9.1 General

9.1.1 Control, ALERT and SAFETY systems are to be in accordance with the requirements of *Pt 6, Ch 1 Control Engineering Systems*.

- 9.1.2 Electrical engineering systems are to be in accordance with the requirements of *Pt 6, Ch 2 Electrical Engineering*.
- 9.1.3 A gas detection system with audible and visual alarm is to be provided for spaces, containing BWT equipment, which may present a hazardous atmosphere. The alarm is also to be provided on the bridge, at manned ballast water control station(s) and in the engine control room, as applicable. BWTS shutdown is to be activated at a concentration of not more than 40 per cent of Lower Explosive Limit (LEL).
- 9.1.4 Gas detection equipment is to be designed, installed and tested in accordance with IEC 60079-29-1 *Explosive atmospheres – Part 29-1: Gas detectors – Performance requirements of detectors for flammable gases*, and is to be suitable for the gases to be detected.
- 9.1.5 Failure of a BWTS power or control system is not to render the BWTS hazardous and is not to affect the operation of essential systems.
- 9.1.6 Active or passive monitoring systems with alarm and safeguards are to be provided to mitigate risks and to ensure the safety of the ship and its occupants.

■ Section 10 Structural and Space categorisation requirements

10.1 Structural requirements

10.1.1 The structural requirements are to comply with the relevant LR Rules and statutory requirements as applicable and separately approved. Consideration is to be given to BWTS space boundaries, fire integrity, hull penetrations and chemical storage tank constructions, if fitted.

10.2 Ballast tanks requirements

10.2.1 Tanks which could be subjected to over or under pressure are to be fitted with Pressure-Vacuum valves and a means of pressure measurement. Deviation from normal working pressure is to activate an alarm and is to shut down the BWTS. The pressure at which shutdown is to occur is to be set in accordance with the tank manufacturer's recommendations.

10.3 Chemical storage tank requirements

10.3.1 A means of controlling overflow is to be provided for the chemical storage tanks. Arrangements are to comply with the Rules for Ships for Liquid Chemicals, *Ch 1, 8.2 Cargo tank venting 8.2.3, Ch 1, 8.2 Cargo tank venting 8.2.3 and Ch 1, 15.19 Overflow control*.

10.3.2 Tanks for chemicals which react in a hazardous manner with other chemicals, residues or mixtures, are to:

- (a) be segregated from such other tanks by means of a cofferdam, void space, cargo pump-room, pump-room, empty tank, or tank containing a mutually compatible chemical;
- (b) have separate pumping and piping systems which shall not pass through other tanks containing such chemicals, unless encased in a tunnel;
- (c) have separate tank venting systems.

10.3.3 The tank and associated gauging requirements indicated in the *Chapter 17 Summary of minimum requirements*, columns f, g, h and j are to be complied with, as applicable to the chemicals being carried.

10.3.4 Secondary containment is to be provided for all free standing chemical storage tanks. Special consideration is to be given to storage tanks situated in high fire risk areas such as machinery spaces of category A.

10.4 BWTS space categorisation requirements

10.4.1 BWTS location, and ventilation requirements for spaces containing BWTS are to be in accordance with the requirements of *Table 25.10.1 Space categorisation and installation requirements*.

Table 25.10.1 Space categorisation and installation requirements

	BWTS which generates or uses hazardous material (i.e. Electro chlorination, chemical injection, ozone, etc.) ³	BWTS which does not generate or use hazardous material (UV reactor, ultra sound, mechanical filtration)
Machinery space of category A	Fitted with mechanical ventilation providing at least six (6) air changes per hour	Provide with adequate ventilation
Other machinery spaces		
Accommodation space	Not allowed to install	Not allowed to install
Cargo area ²	Fitted with mechanical ventilation providing at least six (6) air changes per hour	Provide with adequate ventilation
Weather deck ²		
Service spaces ²	Not allowed to install ¹	Not allowed to install ¹
Special category space ²		
<p>Note 1 May be allowed to install subjected to special consideration, see <i>Pt 5, Ch 25, 6.3 Risk assessment of BWTS installation</i></p> <p>Note 2 Installation space in hazardous area is to be fitted with mechanical ventilation system providing at least twenty (20) air changes per hour or as complying with relevant requirements, i.e. IEC60092-502, IBC code, IGC code, etc. whichever is greater.</p> <p>Note 3 For BWTS using ozone generators or electro chlorination with de-gas equipment, six (6) are to be replaced with twenty (20) air changes per hour. BWTS shutdown is to be activated upon failure of the ventilation system.</p>		

10.4.2 For BWTS which generates or uses hazardous materials, the following mitigation measures of *Pt 5, Ch 25, 10.4 BWTS space categorisation requirements 10.4.3 to Pt 5, Ch 25, 10.4 BWTS space categorisation requirements 10.4.6* are to be complied with, as applicable.

10.4.3 Where failure of the BWTS may result in release of hazardous material (e.g. toxic, flammable, etc.), gas detection is to be provided. The BWTS is to be shut down on detection of a gas concentration that is recognised as hazardous, see *Pt 5, Ch 25, 9.1 General 9.1.3*.

10.4.4 For the location of audible and visual alarms, see *Pt 5, Ch 25, 9.1 General 9.1.3*.

10.4.5 Vent arrangement is to be provided to discharge hazardous gas to a safe location on open deck in the event of failure of the BWTS as in *Pt 5, Ch 25, 10.4 BWTS space categorisation requirements 10.4.3*.

10.4.6 Where failure of the BWTS may result in release of hazardous material of flammable nature, electrical equipment is to comply with the requirements of *Pt 6, Ch 2, 14 Electrical equipment for use in explosive gas atmospheres or in the presence of combustible dusts*.

■ Section 11 System arrangement requirements

11.1 General

11.1.1 The BWTS arrangement is to satisfy the requirements of this Section as applicable.

11.2 Installation requirements

11.2.1 BWTS are to be installed to ensure that the treatment system can be efficiently isolated from the ballast water system without impairing ballast water flow.

11.2.2 Transfer of ballast between gas-safe areas and ballast tanks immediately adjacent to cargo tanks which carry either flammable liquids of a flash point not exceeding 60 degrees or liquefied chemicals in bulk is not permitted, unless otherwise stated in this Section. Ballast arrangements on ships carrying liquefied gases in bulk will be subject to special consideration.

11.2.3 Gas-safe areas are not to be rendered hazardous by the use of the BWTS or the connection with the ballast system as indicated above, see *Pt 5, Ch 25, 11.2 Installation requirements 11.2.2*.

11.3 By-pass and isolation arrangement

11.3.1 The BWTS is to be provided with isolation valves to effectively isolate it from any essential ship systems to which it is connected.

11.3.2 By-pass valves, if fitted, see *Pt 5, Ch 25, 4.2 Ballast Water Treatment System ship specific installation appraisal 4.2.5*, are to be accompanied by isolation valves to effectively by-pass and isolate the system.

11.3.3 By-pass and isolation valves are to be provided with remote means of operation and are also to comply with the requirements of *Pt 5, Ch 12, 6.1 Design requirements 6.1.3* and *Pt 5, Ch 12, 6.1 Design requirements 6.1.4* and *Pt 5, Ch 13, 2.3 Valves – Installation and control*.

11.3.4 Failure of power or control systems is not to impair or restrict the by-pass or isolation arrangements or alternatively is to be demonstrating that the fail safe arrangement is in place to ensure the function of by-pass and isolation arrangements.

11.3.5 By-pass and isolation valves are to be provided with position indicators to give remote indication of valve position.

11.3.6 Activation of by-pass or isolation arrangements is to activate an alarm in all stations from which the ballast water operations are controlled and on the navigating bridge.

11.3.7 Isolation and by-pass valves are to be placed in easily accessible positions.

11.4 Ballast arrangement between hazardous and non-hazardous area

11.4.1 Conditions for BWTS connecting with ballast water serving hazardous and non-hazardous areas are to meet the requirements of *Pt 5, Ch 25, 11.4 Ballast arrangement between hazardous and non-hazardous area 11.4.2* to *Pt 5, Ch 25, 11.4 Ballast arrangement between hazardous and non-hazardous area 11.4.6*.

11.4.2 Ballast water discharge from tanks within the hazardous area is not to be connected with the ballast piping serving in the non-hazardous area.

11.4.3 Ballast water for sampling/analysing may be allowed into non-hazardous areas, provided that sampling or analysing systems meet the requirements of *Pt 5, Ch 25, 11.4 Ballast arrangement between hazardous and non-hazardous area 11.4.6*.

11.4.4 Ballast water piping serving non-hazardous areas may be used to fill the ballast tanks in hazardous areas, provided that two non-return valves are installed in series. One of them is to be of a screw-down non-return type.

11.4.5 All pipe penetrations from the non-hazardous area to the hazardous area are to be led above main deck level.

11.4.6 Conditions for transferring ballast water from hazardous areas to non-hazardous areas, for the purpose of sampling/analysing, are to comply with the requirements of *Pt 5, Ch 25, 11.4 Ballast arrangement between hazardous and non-hazardous area 11.4.7* to *Pt 5, Ch 25, 11.4 Ballast arrangement between hazardous and non-hazardous area 11.4.13*, as minimum.

11.4.7 The sampling/analysing unit is to be located within a gas-tight enclosure and provided with mechanical ventilation. Exhaust is to be led to a safe area on the ship.

11.4.8 A remotely-operated stop valve is to be installed in the cabinet for each sample pipe.

11.4.9 A gas detection device is to be installed in the cabinet as per *Pt 5, Ch 25, 9.1 General 9.1.4* and, upon detection, an audible and visual alarm is to be activated at the relevant control station and the above stop valve is to be automatically closed.

11.4.10 Audible and visual alarms are to be connected to the control system and activated upon detection of an explosive gas concentration, i.e. not more than 40 per cent of the Lower Explosive Level (LEL) or upon failure of the mechanical ventilation system.

11.4.11 Pipes are to be of steel or equivalent. Alternative material is subject to special approval. It should also meet the requirements of *Pt 5, Ch 25, 7.2 Side stream piping*.

11.4.12 The return pipe is to be provided with a non-return valve to prevent reverse flow.

11.4.13 The suction and return pipes are to be provided with stop valves close to the penetration of the bulkhead at the gas safe side.

■ *Section 12***Fire safety requirements****12.1 General**

12.1.1 Spaces containing BWTS are to be provided with fixed fire detection and fire alarm systems complying with the International Code for Fire Safety Systems. As a minimum, the following spaces are to be covered:

- chemical storage spaces;
- treatment unit spaces;
- electrical equipment spaces;
- other spaces, if identified in Section 6 *Risk-based studies*.

12.1.2 Fire suppression techniques and medium are to be compatible with the chemicals and gases associated with the BWTS installed. Material Safety Data Sheets (MSDS) should be available and prominently displayed for all chemicals and gases employed in the ballast treatment process.

		CLASSIFICATION
PART	1	REGULATIONS
PART	2	RULES FOR THE MANUFACTURE, TESTING AND CERTIFICATION OF MATERIALS
PART	3	SHIP STRUCTURES (GENERAL)
PART	4	SHIP STRUCTURES (SHIP TYPES)
PART	5	MAIN AND AUXILIARY MACHINERY
PART	6	CONTROL, ELECTRICAL, REFRIGERATION AND FIRE
		CHAPTER 1 CONTROL ENGINEERING SYSTEMS
		CHAPTER 2 ELECTRICAL ENGINEERING
		CHAPTER 3 REFRIGERATED CARGO INSTALLATIONS
		CHAPTER 4 FIRE PROTECTION, DETECTION AND EXTINGUISHMENT REQUIREMENTS
PART	7	OTHER SHIP TYPES AND SYSTEMS
PART	8	RULES FOR ICE AND COLD OPERATIONS

Section

- 1 **General requirements**
- 2 **Essential features for control, alarm and safety systems**
- 3 **Ergonomics of control stations**
- 4 **Unattended machinery space(s) - UMS notation**
- 5 **Machinery operated from a centralised control station - CCS notation**
- 6 **Integrated computer control - ICC notation**
- 7 **Trials**

■ Section 1 General requirements

1.1 General

1.1.1 This Chapter applies to all ships intended to be classed with Lloyd's Register (hereinafter referred to as 'LR'), and is in addition to other relevant Sections of the Rules.

1.1.2 Control engineering systems are to:

- provide control of required services and habitability requirements during defined operational conditions. This is to include, but is not limited to, power generation, propulsion and their associated services;
- provide control of the engineering systems necessary to ensure availability of essential and emergency safety systems during all normal and reasonably foreseeable abnormal conditions;
- provide control of the engineering systems necessary to ensure transitional power supplies remain available;
- be suitably protected against damage to itself under fault conditions and to prevent injury to personnel; and
- not fail in a way which may cause machinery and systems located in hazardous areas to create additional fire or explosion risk.

1.1.3 Control engineering systems on passenger ships having a length of 120 m or more or having three or more main vertical zones (see *Pt 5, Ch 23, 1.2 Definitions 1.2.4* for definitions) are, in addition to the requirements of this Chapter, to be located, designed and arranged to comply with *Pt 5, Ch 23 Safe Return to Port and Orderly Evacuation and Abandonment in Passenger Ships*, as applicable.

1.1.4 LR will be prepared to give consideration to special cases or to arrangements which are equivalent to the Rules. For unconventional designs, see also *Pt 7, Ch 15 Refrigeration Systems and Equipment Serving Provision Stores and Air-Conditioning Installations*.

1.2 Documentation required for design review

1.2.1 The documentation described in *Pt 6, Ch 1, 1.2 Documentation required for design review 1.2.2 to Pt 6, Ch 1, 1.2 Documentation required for design review 1.2.8* is to be submitted for design review.

1.2.2 Where control, alarm and safety systems are intended for the machinery or equipment as defined in *Pt 6, Ch 1, 1.2 Documentation required for design review 1.2.3* the following are to be submitted:

- Description of operation with explanatory diagrams.
- Line diagrams of control circuits.
- List of monitored points.
- List of control points.
- Details of alarms and warnings to be presented by the user interface, including:

(i) an approach to category assignments which is in accordance with the IMO *Code on Alerts and Indicators, 2009* ; and

(ii) for alarms required by these Rules, the intended operator response and the message to be presented.

- Test schedules (for both works testing and sea trials) which should include methods of testing and test facilities provided, see *Pt 6, Ch 1, 1.3 Control, alarm and safety equipment 1.3.1*
- Failure Mode and Effects Analysis (FMEA) where required by other sections of the Rules.
- List of safety functions and details of any overrides, including consequences of use, see *Pt 6, Ch 1, 2.4 Safety systems, general requirements 2.4.8* and *Pt 6, Ch 1, 2.6 Bridge control for main propulsion machinery 2.6.8*.

1.2.3 Plans for the control, alarm and safety systems of the following are to be submitted:

- Air compressors.
- Bilge and ballast systems.
- Cargo pumping systems for tankers.
- Cargo and ballast pumps in hazardous areas.
- Cargo tank, cargo hold, ballast tank and void space instrumentation where such arrangements are specified by other sections of the Rules (e.g. water ingress detection, gas detection).
- Controllable pitch propellers.
- Electric generating plant.
- Fixed water based local application fire-fighting systems, see *Pt 6, Ch 1, 2.9 Fixed water-based local application fire-fighting systems*.
- Incinerators.
- Inert gas generators.
- Main propelling machinery including essential auxiliaries.
- Miscellaneous machinery or equipment (where control, alarm and safety systems are specified by other Sections of the Rules).
- Fuel oil transfer and storage systems.
- Steam raising plant. (Boilers and their ancillary equipment.)
- Steering gear.
- Thermal fluid heaters.
- Transverse thrust units.
- Valve position indicating systems.
- Waste-heat boiler.
- Waterjets for propulsion purposes.
- Windlasses.

1.2.4 **System operational concept.** A description of the intended operation of the control, alarm and safety systems for the main and auxiliary machinery, and other systems essential for the propulsion and safety of the ship. This description is to include a demonstration that the design provides an effective means of operation and control for all ship operating conditions.

1.2.5 **Alarm systems.** Details of the overall alarm system linking the main control station, subsidiary control stations, the bridge area and accommodation are to be submitted.

1.2.6 **Programmable electronic systems.** In addition to the documentation required by *Pt 6, Ch 1, 1.2 Documentation required for design review 1.2.2* the following is to be submitted:

- (a) System requirements specification.
- (b) System functional description.
- (c) System integration plan, see *Pt 6, Ch 1, 2.14 Programmable electronic systems – Additional requirements for integrated systems 2.14.2*.
- (d) Failure Mode and Effects Analysis (FMEA), see *Pt 6, Ch 1, 2.14 Programmable electronic systems – Additional requirements for integrated systems 2.14.5*.
- (e) Details of the hardware configuration in the form of a system block diagram, including input/output schedules.
- (f) Hardware certification details, see *Pt 6, Ch 1, 2.10 Programmable electronic systems - General requirements 2.10.5* and *Pt 6, Ch 1, 2.13 Programmable electronic systems - Additional requirements for essential services and safety critical systems 2.13.3*.

- (g) Software production plans, including applicable procedures, see *Pt 6, Ch 1, 2.10 Programmable electronic systems - General requirements 2.10.20*.
- (h) Factory acceptance, integration and sea trial test schedules for hardware and software.
- (i) Details of data storage arrangements, see *Pt 6, Ch 1, 2.10 Programmable electronic systems - General requirements 2.10.10* and *Pt 6, Ch 1, 2.13 Programmable electronic systems - Additional requirements for essential services and safety critical systems 2.13.6*.

1.2.7 For wireless data communication equipment:

- (a) Details of manufacturer's installation and maintenance recommendations;
- (b) network plan with arrangement and type of aerials and identification of location;
- (c) specification of wireless communication system protocols and management functions, see *Pt 6, Ch 1, 2.12 Additional requirements for wireless data communication links 2.12.4*; and
- (d) details of radio frequency and power levels, including details of those permitted by the National Administration.

1.2.8 Plans showing the location and details of control stations, e.g. control panels and consoles. Location and details of controls and displays on each panel. Detailed user interface specifications. A general arrangement plan of control rooms showing the position of consoles, handrails, operator area, lighting, door and window arrangements. Drawing of HVAC systems including vent arrangements.

1.2.9 **Fire detection systems.** Plans showing the system operation, and the type and location of all machinery space fire detector heads, manual call points and the fire detector indicator panel(s) are to be submitted. The plans are to indicate the position of the fire detectors in relation to significant items of machinery, ventilation and extraction openings.

1.3 Control, alarm and safety equipment

1.3.1 Equipment associated with control, alarm and safety systems as defined in *Pt 6, Ch 1, 1.2 Documentation required for design review 1.2.3* are to be surveyed at the manufacturers' works in accordance with the approved test schedule see *Pt 6, Ch 1, 1.2 Documentation required for design review 1.2.2*, and the inspection and testing are to be to the Surveyor's satisfaction.

1.3.2 Equipment used in control, alarm and safety systems is to be suitable for its intended purpose, and accordingly, whenever practicable, be selected from the *List of Type Approved Products* published by LR. A copy of the *Procedure for LR Type Approval System* will be supplied on application. For fire detection alarm systems, see *Pt 6, Ch 1, 2.8 Fire detection alarm systems 2.8.2* and for programmable electronic systems, see *Pt 6, Ch 1, 2.10 Programmable electronic systems - General requirements 2.10.5* and *Pt 6, Ch 1, 2.13 Programmable electronic systems - Additional requirements for essential services and safety critical systems 2.13.3*.

1.3.3 Where equipment requires a controlled environment, an alternative means is to be provided to maintain the required environment in the event of a failure of the normal air conditioning system, see also *Table 14.12.3 Miscellaneous machinery: Alarms and safeguards* in *Pt 5, Ch 14*.

1.3.4 Assessment of performance parameters, such as accuracy, repeatability, etc. are to be in accordance with an acceptable National or International Standard, e.g. IEC 60051: *Direct acting indicating analogue electrical measuring instruments and their accessories* (all parts).

1.3.5 Special consideration will be given to arrangements that comply with a relevant and acceptable National or International Standard, such as IEC 60092-504: *Electrical installations in ships - Part 504: Special features - Control and instrumentation*.

1.4 Alterations and additions

1.4.1 When an alteration or addition to the approved system(s) is proposed, plans are to be submitted for approval. The alterations or additions are to be carried out under survey and the installation and testing are to be to the Surveyor's satisfaction.

1.4.2 Details of proposed software modifications are to be submitted for consideration. Modifications are to be undertaken in accordance with defined modification processes which are part of the supplier's or system integrator's quality management system. The following documentation is to be submitted:

- (a) Project-specific software modification plan.
- (b) An impact analysis which identifies the effect(s) of the proposed modification. The results of the analysis are to be used to inform the extent of verification and validation that is to be applied. This analysis is to consider both the local impact and, where applicable, the system level impact of the modification.
- (c) Configuration management records that satisfy the requirements of ISO 10007, to demonstrate the traceability of the proposed modification.

(d) Factory acceptance, integration and sea trial test schedules as determined by the impact analysis in *Pt 6, Ch 1, 1.4 Alterations and additions 1.4.2.*

(e) Updated documentation as detailed in *Pt 6, Ch 1, 1.2 Documentation required for design review 1.2.5.*

1.4.3 Verification and validation activities are to demonstrate that the modified functionality performs as expected and that the modification has not unintentionally modified functionality outside the scope of the modification.

1.4.4 Software versions are to be uniquely identified by number, date or other appropriate means. Modifications are not to be made without also changing the version identifier. A record of changes to the system since the original issue (and their identification) is to be maintained and made available to the LR Surveyor on request.

1.5 Definitions

1.5.1 An Emergency Stop (E-Stop) is a safeguard instigated by a single human action. It requires a stop of all movement within the controlled system as rapidly as possible to prevent a hazard occurring or to reduce an existing hazard to persons, machinery or the vessel.

1.5.2 An Emergency Trip (E-Trip) is a safeguard instigated by a single human action and means the disconnection of fuel, electrical, hydraulic or other power source from the controlled system to prevent a hazard occurring or to reduce an existing hazard to persons, machinery or the vessel. Movement within the system may be allowed to continue.

1.5.3 An Emergency Stop Function may be either an Emergency Stop or Emergency Trip, as appropriate to the system and risk being controlled.

1.5.4 Alarm System: a system which will alert relevant personnel to faults, abnormal situations and other conditions requiring attention in the machinery and the safety and control systems.

1.5.5 Control System: a system which responds to input signals from the process and/or operator and generates output signals causing the equipment under control to operate in the desired manner.

1.5.6 Failure: a loss of the ability of a structure, system or element to function within acceptance criteria.

1.5.7 Fail safe: a system design such that, when a failure occurs, the system reverts to the least hazardous state.

1.5.8 A reasonably foreseeable abnormal condition is an event, incident or failure that :

- has happened and could happen again;
- is planned for (e.g. emergency actions cover such a situation, maintenance is undertaken to prevent it, etc.).

They should be identified by:

- using analysis processes that were capable of revealing abnormal conditions;
- employing a mix of personnel including competent safety / risk professionals and those with relevant domain knowledge and understanding to apply the processes;
- referencing relevant events and historic data; and
- documenting the results of the analysis.

1.5.9 Safety System: a designated system that:

- implements the required safety functions necessary to achieve or maintain a safe state for the equipment under control; and
- is intended to achieve, on its own or with other safety systems, the necessary safety needed for the required safety functions.

1.5.10 Safe State: the state of equipment under control when safety is achieved. For some situations, a safe state only exists so long as the equipment under control is continuously controlled. Such continuous control may be for a short or indefinite period.

1.5.11 System: a set of elements which interact according to a design, where an element of a system can be another system, called a sub-system, which may be a controlling system or a controlled system, and may include hardware, software and human interaction.

■ Section 2**Essential features for control, alarm and safety systems****2.1 General**

2.1.1 Systems complying with ISO 17894, *Ships and marine technology – Computer applications – General principles for the development and use of programmable electronic systems in marine applications*, may be accepted as meeting the requirements of this Section, in which case evidence of compliance is to be submitted for consideration.

2.2 Control stations for machinery

2.2.1 A system of alarm and warning displays and controls is to be provided which readily ensures identification of faults in the machinery and satisfactory supervision of related equipment by duty personnel. This may be provided at a main control station or, alternatively at subsidiary control stations. In the latter case, a master alarm display is to be provided at the main control station showing which of the subsidiary control stations is indicating a fault condition.

2.2.2 At the main control station (if provided) or close to the subsidiary stations (if fitted) means of communication with the bridge area, the accommodation for engineering personnel and, if necessary, the machinery space are to be provided.

2.2.3 Where operator interfaces are installed in the wheelhouse, illumination should not interfere with night vision. All illumination and lighting of instruments, keyboards and controls are to be adjustable to zero illumination, except for lighting for visual indication of alarms and the controls of dimmers, which are to remain readable.

2.2.4 Provision is to be made at the main control station, or subsidiary control stations as appropriate, for the operation of an engineers' alarm which is to be clearly audible in the engineers' accommodation.

2.2.5 Provision is to be made at the main control station and any other subsidiary control station from which the main propulsion and auxiliary machinery or associated equipment may be controlled to indicate which station is in control.

2.2.6 Control of machinery and associated equipment is to be possible only from one station at a time.

2.2.7 Changeover between control stations is to be arranged so that it may only be effected with the acceptance of the station taking control. The system is to be provided with interlocks or other suitable means to ensure effective transfer of control.

2.3 Alarm systems, general requirements

2.3.1 Machinery, safety and control system faults are to be indicated at the relevant control stations to advise duty personnel of a fault condition. The presence of unrectified faults is to be clearly indicated at all times.

2.3.2 Alarms and warnings associated with machinery and equipment required to satisfy this sub-Section are to be categorised according to the urgency and type of response required by the crew, as described in the *IMO Code on Alerts and Indicators, 2009*. The assignment of a category to each alert is to be evaluated on the basis not only of the machinery or equipment being monitored, but also the complete installation. Categories not included in an alarm system may be omitted from the system design. Details of alternative alert management proposals supported with evidence of service experience may be submitted for consideration by LR.

2.3.3 Where the facility to provide messages in association with alarms and warnings exists, messages accompanying alarms and warnings are to describe the condition and indicate the intended response required by the crew.

2.3.4 Where the facility to provide messages in association with alarms and warnings exists messages of different categories are to be clearly distinguishable from each other. Alarms associated with machinery, safety and control system faults are to be clearly distinguishable from other alarms (e.g. fire, general alarm).

2.3.5 Where alarms are displayed as group alarms provision is to be made to identify individual alarms at the main control station (if fitted) or alternatively at subsidiary control stations.

2.3.6 All alarms are to be both audible and visual. If arrangements are made to silence audible signals they are not to extinguish visual indications.

2.3.7 Acknowledgement of visual alarms is to be clearly indicated.

2.3.8 Acknowledgement of alarms at positions outside a machinery space is not to silence the audible signal or extinguish the visual indication in that machinery space.

2.3.9 If an alarm has been acknowledged and a second fault occurs prior to the first being rectified, audible signals and visual indications are again to operate. Where alarms are displayed at a local panel adjacent to the machinery and with arrangements to provide a group or common fault alarm in the control room, the occurrence of a second fault prior to the first alarm being rectified need only be displayed at the local panel; however, the group alarm is to be re-initiated. Unacknowledged alarms on monitors are to be distinguished by either flashing text or a flashing marker adjacent to the text. A change of colour will not in itself be sufficient to distinguish between acknowledged and unacknowledged alarms.

2.3.10 For the detection of transient faults which are subsequently self-correcting, alarms are required to lock in until accepted.

2.3.11 The alarm system is to be arranged with automatic changeover to a standby power supply in the event of a failure of the normal power supply. Where an alarm system could be adversely affected by an interruption in power supply, changeover to the standby power supply is to be achieved without a break.

2.3.12 Failure of any power supply to the alarm system is to operate an audible and visual alarm.

2.3.13 The alarm system should be designed with self-monitoring properties. Insofar as practicable, any fault in the alarm system should cause it to fail to the alarm condition.

2.3.14 The alarm system is to be capable of being tested during normal machinery operation, see *Pt 6, Ch 1, 7.1 General 7.1.2*.

2.3.15 The alarm system is to be designed as far as practicable to function independently of control and safety systems such that a failure or malfunction in these systems will not prevent the alarm system from operating.

2.3.16 Disconnection or manual overriding of any part of the alarm system is to be clearly indicated.

2.3.17 When alarm systems are provided with means to adjust their set point, the arrangements are to be such that the final settings can be readily identified.

2.3.18 Where monitors are provided at the station in control and, if fitted, in the duty engineer's accommodation, they are to provide immediate display of new alarm information regardless of the information display page currently selected. This may be achieved by provision of a dedicated alarm monitor, a dedicated area of screen for alarms or other suitable means.

2.3.19 Where practicable, alarms displayed on monitors are to be displayed in the order in which they occur. Alarms requiring manual shutdown or slow-down action are to be given visual prominence.

2.4 Safety systems, general requirements

2.4.1 Safety systems are to operate automatically in case of serious faults endangering the machinery, so that:

- (a) normal operating conditions are restored, e.g. by the starting of standby machinery, or
- (b) the operation of the machinery is temporarily adjusted to the prevailing conditions, e.g. by reducing the output of the machinery, or
- (c) the machinery is protected from critical conditions by shutting off the fuel or power supplies thereby stopping the machinery.

2.4.2 The safety system required by *Pt 6, Ch 1, 2.4 Safety systems, general requirements 2.4.1* is to be designed as far as practicable to operate independently of the control and alarm systems, such that a failure or malfunction in the control and alarm systems will not prevent the safety system from operating, see *Pt 5, Ch 14, 12.1 General 12.1.4*.

2.4.3 For safety systems required by *Pt 6, Ch 1, 2.4 Safety systems, general requirements 2.4.1* and *Pt 6, Ch 1, 2.4 Safety systems, general requirements 2.4.1* complete independence from other control systems is not necessary.

2.4.4 Safety systems for different items of the machinery plant are to be arranged so that failure of the safety system of one part of the plant will not interfere with the operation of the safety system in another part of the plant.

2.4.5 The safety system is to be designed to 'fail safe'. The characteristics of the 'fail safe' operation are to be evaluated on the basis not only of the safety system and its associated machinery, but also the complete installation. Failure of a safety system is to initiate an audible and visual alarm.

2.4.6 When a safety system is activated, an audible and visual alarm is to be provided to indicate the cause of the safety action.

2.4.7 The safety system is to be manually reset before the relevant machinery can be restarted.

2.4.8 Where arrangements are provided for overriding a safety system, they are to be such that inadvertent operation is prevented. Visual indication is to be given at the relevant control station(s) when a safety override is operated. The consequences of overriding a safety system are to be established and documented.

2.4.9 The safety system is to be arranged with automatic changeover to a standby power supply in the event of a failure of the normal power supply.

2.4.10 Failure of any power supply to a safety system is to operate an audible and visual alarm.

2.4.11 When safety systems are provided with means to adjust their set point, the arrangements are to be such that the final settings can be readily identified.

2.4.12 As far as practicable, the safety system required by *Pt 6, Ch 1, 2.4 Safety systems, general requirements 2.4.1* is to be arranged to effect a rapid reduction in speed or power.

2.5 Control systems, general requirements

2.5.1 Control systems for machinery operations are to be stable throughout their operating range.

2.5.2 Failure of any power supply to a control system is to operate an audible and visual alarm.

2.5.3 Control systems should be designed to 'fail safe'. The characteristics of the 'fail safe' operation are to be evaluated on the basis not only of the control system and its associated machinery, but also the complete installation.

2.5.4 The control system is to be designed such that normal operation of the controls cannot induce detrimental mechanical or thermal overloads in the machinery.

2.5.5 Remote or automatic controls are to be provided with suitable instrumentation at the relevant control stations to ensure effective control by duty personnel and to indicate that the system is functioning correctly.

2.5.6 When control systems are provided with means to adjust their sensitivity or set point, the arrangements are to be such that the final settings can be readily identified.

2.5.7 Failure of a control system is not to result in the loss of ability to provide essential services by alternative means. This may be achieved by manual control or redundancy within the control system or redundancy in machinery and equipment, *see also Pt 6, Ch 1, 2.13 Programmable electronic systems - Additional requirements for essential services and safety critical systems 2.13.2*. Instrumentation is to be provided at local manual control stations to ensure effective operation of the machinery by duty personnel.

2.6 Bridge control for main propulsion machinery

2.6.1 Means are to be provided to ensure satisfactory control of propulsion from the bridge in both the ahead and astern directions.

2.6.2 The following indications are to be provided on the bridge:

- (a) Propeller speed.
- (b) Direction of rotation of propeller for a fixed pitch propeller or pitch position for a controllable pitch propeller, *see also Pt 5, Ch 7, 5.3 Controllable pitch propellers and transverse thrust units*.
- (c) Direction and magnitude of thrust.
- (d) Clutch position, where applicable.
- (e) Shaft brake position, where applicable.

2.6.3 The propeller speed, direction of rotation and, if applicable, the propeller pitch are to be controlled from the bridge under all sea-going and manoeuvring conditions.

2.6.4 Remote control of the propulsion machinery is to be from only one control station at any one time, *see also Pt 6, Ch 1, 2.2 Control stations for machinery 2.2.6*. Main propulsion control units on the navigating bridge may be interconnected. Means are to be provided at the control station to ensure smooth transfer of control between the bridge and other control stations.

2.6.5 Means of control, independent of the bridge control system, are to be provided on the bridge to enable the watchkeeper to stop the propulsion machinery in an emergency.

2.6.6 Audible and visual alarms are to operate on the bridge and in the alarm system required by *Pt 6, Ch 1, 4.2 Alarm system for machinery* if any power supply to the bridge control system fails. Where practicable, the preset speed and direction of thrust are to be maintained until corrective action is taken.

2.6.7 Two means of communication are to be provided between the bridge and the main control station in the machinery space. One of these means may be the bridge control system; the other is to be independent of the main electrical power supply, *see also Pt 6, Ch 1, 2.2 Control stations for machinery 2.2.2 and Pt 5, Ch 1, 4 Machinery room arrangements*.

2.6.8 Automation systems are to be designed in a manner such that a threshold warning of impending or imminent slow-down or shutdown of the propulsion system is given to the officer in charge of the navigational watch in time to assess navigational circumstances in an emergency. In particular, the systems are to control, monitor, report, alert and take safety action to slow down or stop propulsion while providing the officer in charge of the navigational watch an opportunity to intervene manually, except for those cases where manual intervention will result in total failure of the engine and/or propulsion equipment within a short time, for example, in the case of overspeed.

2.7 Valve control systems

2.7.1 Where cargo, bilge, ballast, fuel oil transfer and sea valves for engine services are operated by remote or automatic control, the requirements of *Pt 6, Ch 1, 2.7 Valve control systems 2.7.2 to Pt 6, Ch 1, 2.7 Valve control systems 2.7.5* are to be satisfied.

2.7.2 Failure of control system power or actuator power is not to permit a valve to move to an unsafe condition.

2.7.3 Positive indication is to be provided at the remote control station for the service to show the actual valve position or alternatively that the valve is fully open or closed.

2.7.4 Equipment located in places which may be flooded is to be capable of operating when submerged.

2.7.5 A secondary means of operating the valves, which may be by local manual control, is to be provided.

2.7.6 For requirements applicable to closing appliances on scuppers and sanitary discharges, see *Pt 3, Ch 12, 4.2 Closing appliances*. For power supplies on passenger ships, see *Pt 6, Ch 2, 3.3 Emergency source of electrical power in passenger ships*.

2.8 Fire detection alarm systems

2.8.1 Fire detection and fire alarm systems are to comply with *Chapter 9 – Fixed fire detection and fire alarm systems* of the *Fire Safety Systems Code (FSS), Regulation 7 - Detection and alarm* of SOLAS Ch II-2, Part C and *Pt 6, Ch 1, 2.8 Fire detection alarm systems 2.8.2 to Pt 6, Ch 1, 2.8 Fire detection alarm systems 2.8.23* as applicable.

2.8.2 Fire detection control units, indicating panels, detector heads, manual call points and short-circuit isolation units are to satisfy the requirements of the Type Approval Test Specification Number 1 given in LR's Type Approval System for an environmental categories appropriate for the locations in which they are intended to operate. For addressable systems, see *also Pt 6, Ch 1, 2.10 Programmable electronic systems - General requirements*. FSS requires compliance of detectors with specific standards; refer to *Chapter 9 – Fixed fire detection and fire alarm systems* Section 2.3.1.2.

2.8.3 The alarm system is to be designed with self-monitoring properties. Power or system failures are to operate in accordance with FSS Code *Chapter 9 – Fixed fire detection and fire alarm systems*, Section 2.5.1.5.

2.8.4 When fire detectors are provided with means to adjust their sensitivity, the arrangements are to be such that the set point can be fixed and readily identified.

2.8.5 The fire detector heads are to be of a type which can be tested and reset without the renewal of any component. Testing of detector heads is to be in accordance with FSS Code, *Chapter 9 – Fixed fire detection and fire alarm systems* Section 2.5.2.

2.8.6 When it is intended that a particular loop is to be temporarily switched off, this state is to be clearly indicated at the fire detection indicating panels.

2.8.7 When it is intended that a particular detector(s) is (are) to be temporarily switched off locally, this state is to be clearly indicated at the local position. Reactivation of the detector(s) is to be performed automatically after a preset time.

2.8.8 It is to be demonstrated to the Surveyor's satisfaction that detector heads are located in accordance with *FSS Code - Fire Safety Systems – Resolution MSC.98(73)* Section 2.4.2.1.

2.8.9 An audible fire alarm is to be provided in accordance with SOLAS, Ch II-2, Part C, *4 Protection of machinery spaces*.

2.8.10 Where an automatic fire detection system is to be fitted in a machinery space, the requirements of *Pt 6, Ch 1, 2.8 Fire detection alarm systems 2.8.11 to Pt 6, Ch 1, 2.8 Fire detection alarm systems 2.8.15* are also to be satisfied. See *also* SOLAS 1974, as amended *Regulation 7 - Detection and alarm*, or *Pt 6, Ch 4 Fire Protection, Detection and Extinction Requirements* as applicable.

2.8.11 Detector heads are to be located in the machinery spaces so that all potential fire outbreak points are guarded. A combination of detectors is to be provided to ensure that the system will react to all possible fire characteristics.

2.8.12 Fire detection indicating panels are to denote the section in which a detector or manually operated call point has operated. At least one indicating panel is to be so located that it is easily accessible to responsible members of the crew at all times. An indicating panel is to be located on the navigating bridge.

2.8.13 A fire detection control unit is to be located in the navigating bridge area, the fire-control station, or in some other position such that a fire in the machinery spaces will not render it inoperable.

2.8.14 The audible fire-alarm is to be immediately audible on all parts of the navigating bridge, the fire-control station, the crew accommodation areas and the machinery spaces.

2.8.15 Facilities are to be provided in the fire detection system to initiate manually the fire alarm from the following locations:

- (a) Positions adjacent to all exits from machinery spaces.
- (b) Navigating bridge.
- (c) Control station in engine room.
- (d) Fire-control station.

2.8.16 Fire detection systems within the accommodation spaces and cabin balconies are also to comply with *Pt 6, Ch 1, 2.8 Fire detection alarm systems 2.8.17 to Pt 6, Ch 1, 2.8 Fire detection alarm systems 2.8.22*.

2.8.17 In passenger ships, the fixed fire detection and fire alarm systems are to be capable of remotely and individually identifying each detector and manually operated call point. On other ships, indicating units are to denote, as a minimum, the section in which a detector or manually operated call point has operated. At least one indication unit is to be so located that it is easily accessible to responsible members of the crew. One indicating unit is to be located on the navigating bridge if the control panel is located in the central control station.

2.8.18 Clear information is to be displayed on or adjacent to each indicating unit about the spaces covered and the location of the section and, for passenger ships, each detector and manually operated call point.

2.8.19 The fire detection system is not to be used for any other purpose, except those detailed in FSS Code, *Chapter 9 – Fixed fire detection and fire alarm systems* Section 2.1.2.

2.8.20 The fire-control panel is to be located on the navigating bridge or in a central fire-control station and may form part of that panel specified in *Pt 6, Ch 1, 2.8 Fire detection alarm systems 2.8.13*. For passenger ships carrying more than 36 passengers, the fire-control panel is to be located in the continuously manned central control station.

2.8.21 Detectors and manually operated call points are to be grouped into sections. The activation of any detector or manually operated call point is to initiate a visual and audible fire signal at the control panel and indicating units. If the signals have not received attention within two minutes an audible alarm is to be automatically sounded throughout the crew accommodation and service spaces, control stations and machinery spaces of Category A. This alarm sounder system need not be an integral part of the detection system.

2.8.22 A section of fire detectors and manually operated call points are to comply with FSS Code, *Chapter 9 – Fixed fire detection and fire alarm systems*, Section 2.4.1.2.

2.8.23 For electrical engineering requirements, see *Pt 6, Ch 2, 17.1 Fire detection and alarm systems*.

2.9 Fixed water-based local application fire-fighting systems

2.9.1 Where fixed water-based local application firefighting systems are installed in accordance with *SOLAS - International Convention for the Safety of Life at Sea* as amended Ch. II-2/C, 5 *Fire extinguishing arrangements in machinery spaces*, arrangements are to be in accordance with this sub-Section.

2.9.2 Systems are to be available for immediate use and arranged for manual activation from inside and outside the protected space. See also *Pt 6, Ch 2, 17.3 Fixed water-based local application fire-fighting systems 17.3.4*.

2.9.3 The activation of a system is not to result in loss of electrical power or reduction of the manoeuvrability of the ship and is not to require confirmation of space evacuation or sealing, see also *Pt 6, Ch 2, 17.3 Fixed water-based local application fire-fighting systems 17.3.12*.

2.9.4 System zones and protected areas are to be arranged to allow essential services to be provided by machinery and/or equipment located outside areas affected by direct spray or extended water in the event of a system activation, where the machinery and/or equipment is duplicated or otherwise replicated to provide redundancy.

2.9.5 A control panel is to be provided for managing actions such as opening of valves, starting of pumps and initiation of alarms and warnings and processing information from detectors. This panel is to be independent of the fire detection control unit required by *Pt 6, Ch 1, 2.8 Fire detection alarm systems*.

2.9.6 Alarms are to be initiated upon activation of a system and are to indicate the specific zone activated at the control panel. Alarms are to be provided in each protected space, at an attended machinery control station and in the wheelhouse. The audible signal is to be distinguishable from other safety system signals.

2.9.7 A failure in a manual system activation switch circuit is not to prevent system activation using other installed manual system activation switches or, where installed, automatic activation. The means of activation are to be provided with self-monitoring facilities which will activate an alarm at an attended control station in the event of failure detection.

2.9.8 Where *SOLAS - International Convention for the Safety of Life at Sea* requires the system, additionally, to be capable of automatic release, the arrangements are to be in accordance with *Pt 6, Ch 1, 2.9 Fixed water-based local application fire-fighting systems 2.9.9 to Pt 6, Ch 1, 2.9 Fixed water-based local application fire-fighting systems 2.9.12*.

2.9.9 A minimum of two fire detectors are to be provided for each protected area. One is to be a flame detector and the other is to be a smoke or heat detector, as considered appropriate to the nature of the risk and ambient conditions. The system is to be activated upon detection by two of the detectors. A fault in one detector is to initiate an alarm at an attended control station and is not to inhibit activation of the system under the control of the other detector or manually.

2.9.10 The fire detectors are to be arranged (located, oriented, guarded, etc.) to ensure that a fire in one protected area will not result in the inadvertent automatic activation of a system for another protected area. Guards or barriers provided to comply with this requirement are not to reduce the ability to detect a fire in the protected area.

2.9.11 A fire detection alarm system panel in accordance with *Pt 6, Ch 1, 2.8 Fire detection alarm systems* may be used for receiving fire detection signals. Separate loops are not required provided that the address of the initiating device can be identified at the control panel. The received signals are then to be sent to the control panel required by *Pt 6, Ch 1, 2.9 Fixed water-based local application fire-fighting systems 2.9.5* for processing and action.

2.9.12 The system's fire detection systems and control units are to meet the performance criteria of *SOLAS Ch II/C, Regulation 7 - Detection and alarm* and are to be Type Approved in accordance with *Test Specification Number 1* given in LR's *Type Approval System* for an environmental category appropriate for the locations in which they are intended to operate.

2.10 Programmable electronic systems - General requirements

2.10.1 The requirements of this sub-section are to be complied with where control, alarm or safety systems incorporate programmable electronic equipment. Systems for essential services and safety critical applications, systems incorporating shared data communication links and systems which are integrated are to comply with the additional requirements of *Pt 6, Ch 1, 2.11 Data communication links, Pt 6, Ch 1, 2.13 Programmable electronic systems - Additional requirements for essential services and safety critical systems and Pt 6, Ch 1, 2.14 Programmable electronic systems - Additional requirements for integrated systems* as applicable. For systems complying with *ISO 17894, Ships and marine technology - Computer applications - General principles for the development and use of programmable electronic systems in marine applications*, see *Pt 6, Ch 1, 2.12 Additional requirements for wireless data communication links*.

2.10.2 Where programmable electronic systems share resources, any components that can affect the ability to provide effectively required control, alarm or safety functions are to fulfil the requirements of *Pt 6, Ch 1, 2.10 Programmable electronic systems - General requirements to Pt 6, Ch 1, 2.14 Programmable electronic systems - Additional requirements for integrated systems* related to providing those required functions.

2.10.3 Programmable electronic equipment is to revert to a defined safe state on initial start-up or re-start in the event of failure.

2.10.4 In the event of failure of any programmable electronic equipment, the system, and any other system to which it is connected, is to fail to a defined safe state or maintain safe operation, as applicable.

2.10.5 Programmable electronic equipment is to be certified by a recognised authority as suitable for the environmental conditions in which it is intended to operate, see also *Pt 6, Ch 1, 2.13 Programmable electronic systems - Additional requirements for essential services and safety critical systems 2.13.3*.

2.10.6 Emergency stop functions are to be hard-wired and independent of any programmable electronic equipment. Alternatively, the system providing emergency stop functions is to comply with the requirements of *Pt 6, Ch 1, 2.13 Programmable electronic systems - Additional requirements for essential services and safety critical systems 2.13.2* and/or *Pt 6, Ch 1, 2.13 Programmable electronic systems - Additional requirements for essential services and safety critical systems 2.13.8*.

2.10.7 Programmable electronic equipment is to be provided with self-monitoring capabilities such that hardware and functional failures will initiate an audible and visual alarm in accordance with the requirements of *Pt 6, Ch 1, 2.3 Alarm systems, general requirements* and, where applicable, *Pt 6, Ch 1, 4.2 Alarm system for machinery*. Hardware failure indications are to enable faults to be identifiable at least down to the level of the lowest replaceable unit and the self-monitoring capabilities are to ensure that diagnostic information is readily available.

2.10.8 Means are to be provided to recover or replace data required for safe and effective system operation lost as a result of component failure. The submission required by *Pt 6, Ch 1, 1.2 Documentation required for design review 1.2.6* is to address reinstatement of system operation following data loss.

2.10.9 System configuration, programs and data are to be protected against loss or corruption in the event of failure of any power supply. For essential services and safety critical systems, see *Pt 6, Ch 1, 2.13 Programmable electronic systems - Additional requirements for essential services and safety critical systems 2.13.6*.

2.10.10 Where it is necessary to store data required for system operation in volatile memory, a back-up power supply is to be provided that prevents data loss in the event of loss of the normal power supply. The submission required by *Pt 6, Ch 1, 1.2 Documentation required for design review 1.2.6* is to include details of any routine maintenance necessary and the measures necessary to restore system operation in the event of data loss as a result of power supply failure.

2.10.11 Back-up power supplies required by *Pt 6, Ch 1, 2.10 Programmable electronic systems - General requirements 2.10.10* are to be rated to supply the connected load for a defined period of time that allows sufficient time to restore the supply in the event of loss of the normal power supply as a result of failure of a main source of electrical power. This period is not to be less than 30 minutes.

2.10.12 Where regular battery replacement is required to maintain the availability of volatile memory back-up power supply required by *Pt 6, Ch 1, 2.10 Programmable electronic systems - General requirements 2.10.10*, these are to be included in the schedule of batteries required by *Pt 6, Ch 2, 1.2 Documentation required for design review 1.2.15* and *Pt 6, Ch 2, 12.7 Recording of batteries for emergency and essential services*, irrespective of battery type and size. Applicable entries in this schedule are to note that these batteries are not for safety critical systems or essential or emergency services.

2.10.13 Access to system configuration, programs and data is to be restricted by physical and/or logical means providing effective security against unauthorised alteration.

2.10.14 Where date and time information is required by the equipment, this is to be provided by means of a battery backed clock with restricted access for alteration. Date and time information is to be fully represented and utilised.

2.10.15 Displays and controls are to be protected against liquid ingress due to spillage.

2.10.16 Display units are to comply with the requirements of an acceptable National or International Standard, e.g. IEC 60950-1: *Information technology equipment – Safety - Part 1: General requirements*, in respect of emission of ionising radiation.

2.10.17 Where systems detect fault conditions, any affected mimic diagrams are to ensure that the status of unreliable and incorrect data is clearly identified.

2.10.18 Multi-function displays and controls are to be duplicated and interchangeable where used for the control or monitoring of more than one system, machinery item or item of equipment. At least one unit at the main control station is to be supplied from an independent uninterruptable power system (UPS).

2.10.19 The number of multi-function display and control units provided at the main control station and their power supply arrangements are to be sufficient to ensure continuing safe operation in the event of failure of any unit or any power supply.

2.10.20 Software lifecycle activities, e.g. design, development, supply and maintenance, are to be carried out in accordance with an acceptable quality management system. Project specific software quality plans are to be submitted. These are to demonstrate that the provisions of ISO/IEC 90003: *Software engineering – Guidelines for the application of ISO 9001:2000 to computer software*, or equivalent, are incorporated. The plans are to define responsibilities for the lifecycle activities, including verification, validation, module testing and integration with other components or systems.

2.11 Data communication links

2.11.1 Where control, alarm or safety systems use shared data communication links to transfer data, the requirements of *Pt 6, Ch 1, 2.11 Data communication links 2.11.2* to *Pt 6, Ch 1, 2.11 Data communication links 2.11.10* are to be complied with. The requirements apply to local area networks, fieldbuses and other types of data communication link which make use of a shared medium to transfer control, alarm or safety related data between distributed programmable electronic equipment or systems.

2.11.2 Data communication is to be automatically restored within 45 seconds in the event of a single component failure. Upon restoration, priority is to be given to updating safety critical data and control, alarm and safety related data for essential services. Components comprise all items required to facilitate data communication, including cables, switches, repeaters, software components and power supplies.

2.11.3 Loss of a data communication link is not to result in the loss of ability to operate any essential service by alternative means, *see also Pt 6, Ch 1, 2.12 Additional requirements for wireless data communication links 2.12.2.*

2.11.4 The properties of the data communication link, (e.g. bandwidth, access control method, etc.), are to ensure that all connected systems will operate in a safe, stable and repeatable manner under all operating conditions. The latency of control, alarm and safety related data is not to exceed two seconds.

2.11.5 Protocols are to ensure the integrity of control, alarm and safety related data, and provide timely recovery of corrupted or invalid data.

2.11.6 Means are to be provided to monitor performance and identify hardware and functional failures. An audible and visual alarm is to operate in accordance with the requirements of *Pt 6, Ch 1, 2.3 Alarm systems, general requirements* and, where applicable, *Pt 6, Ch 1, 4.2 Alarm system for machinery* in the event of a failure of an active or standby component.

2.11.7 System self-monitoring capabilities are to be arranged to initiate transition to a defined safe state for the complete installation in the event of data communication failure, *see also Pt 6, Ch 1, 2.5 Control systems, general requirements 2.5.3.*

2.11.8 Means are to be provided to prevent unintended connection or disconnection of any equipment where this may affect the performance of any other systems in operation.

2.11.9 Data cables are to comply with the applicable requirements of *Pt 6, Ch 2, 11 Electric cables, optical fibre cables and busbar trunking systems (busways)*. Other media will be subject to special consideration.

2.11.10 The installation is to provide adequate protection against mechanical damage and electromagnetic interference.

2.11.11 Components are to be located with appropriate segregation such that the risk of mechanical damage or electromagnetic interference resulting in the loss of both active and standby components is minimised. Duplicated data communication links are to be routed to give as much physical separation as is practical.

2.12 Additional requirements for wireless data communication links

2.12.1 The requirements of this sub-Section are in addition to *Pt 6, Ch 1, 2.11 Data communication links* and apply to systems incorporating wireless data communication links.

2.12.2 Wireless data communication links are not to be used for safety critical systems or essential services that are required for the propulsion or safety of the ship, except as permitted by *Pt 6, Ch 1, 2.12 Additional requirements for wireless data communication links 2.12.3.*

2.12.3 For services not required to operate continuously, wireless data communication links may be considered where an alternative means of operation can be brought into action within an acceptable period of time.

2.12.4 Wireless data communication is to employ recognised international wireless communication system protocols that incorporate the following:

- (a) Message integrity: fault prevention, detection, diagnosis and correction, ensuring that the received message is not corrupted or altered when compared to the transmitted message.
- (b) Configuration and device authentication: is to permit connection only of devices that are included in the system design.
- (c) Message encryption: protection of the confidentiality and/or criticality of the data content.
- (d) Security management: protection of network assets and prevention of unauthorised access to network assets.

2.12.5 The wireless system is to comply with the radio frequency and power level requirements of the International Telecommunications Union and any requirements of the National Administration with which the ship is registered.

2.12.6 Compliance with different port state and local regulations pertaining to the use of radio-frequency transmission that would prohibit the operation of a wireless data communication link, due to frequency and power level restrictions, is not addressed by these requirements and is the responsibility of the Owner and Operator.

2.13 Programmable electronic systems - Additional requirements for essential services and safety critical systems

2.13.1 The requirements of *Pt 6, Ch 1, 2.13 Programmable electronic systems - Additional requirements for essential services and safety critical systems 2.13.2 to Pt 6, Ch 1, 2.13 Programmable electronic systems - Additional requirements for essential services and safety critical systems 2.13.10* are to be complied with where control, alarm or safety systems for essential services, as defined by *Pt 6, Ch 2, 1.6 Definitions*, or safety critical systems, incorporate programmable electronic equipment.

- (a) Safety critical systems are those which provide functions intended to protect persons from physical hazards (e.g. fire, explosion, etc.), or to prevent mechanical damage which may result in the loss of an essential service (e.g. main engine low lubricating oil pressure shutdown).
- (b) Applications that are not essential services may also be considered to be safety critical (e.g. domestic boiler low water level shutdown).

2.13.2 Alternative means of safe and effective operation are to be provided for essential services and, wherever practicable, these are to be provided by a fully independent hard-wired back-up system. Where these alternative means are not independent of any programmable electronic equipment, the software is to satisfy the requirements of LR's *Software Conformity Assessment System - Assessment Module GEN1 (1994)*.

2.13.3 Items of programmable electronic equipment used to implement control, alarm or safety functions are to be Type Approved in accordance with LR's *Type Approval System Test Specification Number 1 (2013)*. Type approval to an alternative and relevant National or International Standard may be submitted for consideration.

2.13.4 The system is to be configured such that control, alarm and safety function groups are independent. A failure of the system is not to result in the loss of more than one of these function groups. Proposals for alternative arrangements providing an equivalent level of safety will be subject to special consideration.

2.13.5 For essential services, the system is to be arranged to operate automatically from an alternative power supply in the event of a failure of the normal supply.

2.13.6 Volatile memory is not to be used to store data required for:

- an essential service or safety critical functions; or
- ensuring safety or preventing damage, including during start-up or re-start.

Alternative proposals which demonstrate that an equivalent level of system integrity will be achieved may be submitted for consideration.

2.13.7 Failure of any power supply is to initiate an audible and visual alarm in accordance with the requirements of *Pt 6, Ch 1, 2.3 Alarm systems, general requirements* and, where applicable, *Pt 6, Ch 1, 4.2 Alarm system for machinery*.

2.13.8 Where it is intended that the programmable electronic system implements an emergency stop function or safety critical functions, the software is to satisfy the requirements of LR's *Software Conformity Assessment System - Assessment Module GEN1 (1994)*. Alternative proposals providing an equivalent level of system integrity will be subject to special consideration, e.g. fully independent hard-wired back-up system, redundancy with design diversity, etc.

2.13.9 Control, alarm and safety related information is to be displayed in a clear, unambiguous and timely manner, and, where applicable, is to be given visual prominence over other information on the display.

2.13.10 Means of access to safety critical functions are to be dedicated to the intended function and readily distinguishable.

2.14 Programmable electronic systems – Additional requirements for integrated systems

2.14.1 The requirements of *Pt 6, Ch 1, 2.14 Programmable electronic systems – Additional requirements for integrated systems 2.14.2 to Pt 6, Ch 1, 2.14 Programmable electronic systems – Additional requirements for integrated systems 2.14.7* apply to integrated systems providing control, alarm or safety functions in accordance with the Rules, including systems capable of independent operation interconnected to provide co-ordinated functions or common user interfaces. Examples include integrated machinery control, alarm and monitoring systems, power management systems and safety management systems providing a grouping of fire, passenger, crew or ship safety functions, see *Pt 6, Ch 2, 17 Fire safety systems to Pt 6, Ch 2, 19 Ship safety systems*.

2.14.2 System integration is to be managed by a single designated party, and is to be carried out in accordance with a defined procedure identifying the roles, responsibilities and requirements of all parties involved. This procedure is to be submitted for consideration where the integration involves control functions for essential services or safety functions including fire, passenger, crew, and ship safety.

2.14.3 The system requirements specification, see *Pt 6, Ch 1, 1.2 Documentation required for design review 1.2.6*, is to identify the allocation of functions between modules of the integrated system, and any common data communication protocols or interface standards required to support these functions.

2.14.4 Reversionary modes of operation are to be provided to ensure safe and graceful degradation in the event of one or more failures. In general, the integrated system is to be arranged such that the failure of one part will not affect the functionality of other parts, except those that require data from the failed part.

2.14.5 Where the integration involves control functions for essential services or safety functions, including fire, passenger, crew, and ship safety, a Failure Mode and Effects Analysis (FMEA) is to be carried out in accordance with IEC 60812: *Analysis techniques for system reliability – Procedure for failure mode and effects analysis (FMEA)*, or an equivalent and acceptable National or International Standard and the report and worksheets submitted for consideration. The FMEA is to demonstrate that the integrated system will 'fail-safe', see *Pt 6, Ch 1, 2.4 Safety systems, general requirements 2.4.5* and *Pt 6, Ch 1, 2.5 Control systems, general requirements 2.5.3*, and that essential services in operation will not be lost or degraded beyond acceptable performance criteria where specified by these Rules.

2.14.6 The quantity and quality of information presented to the operator are to be managed to assist situational awareness in all operating conditions. Excessive or ambiguous information that may adversely affect the operator's ability to reason or act correctly is to be avoided, but information needed for corrective or emergency actions is not to be suppressed or obscured in satisfying this requirement.

2.14.7 Where information is required by the Rules or by National Administration requirements to be continuously displayed, the system configuration is to be such that the information may be viewed without manual intervention, e.g. the selection of a particular screen page or mode of operation. See also *Pt 6, Ch 1, 2.10 Programmable electronic systems - General requirements 2.10.16*.

■ Section 3 Ergonomics of control stations

3.1 Objectives

3.1.1 In order to take account of operator tasks at control stations, enhance usability and reduce human error, the layout arrangements are to comply with the requirements set out in *Pt 6, Ch 1, 3.2 Control station layout*.

3.1.2 In order to establish a working environment that has minimum distractions, is sufficiently comfortable, helps maintain vigilance and maximises communication amongst operators at main control stations, the requirements of *Pt 6, Ch 1, 3.3 Physical environment* are to be complied with.

3.1.3 The requirements of *Pt 6, Ch 1, 3.4 Operator interface* apply to operator interfaces for essential engineering systems located either locally, remotely or within the main control room. The requirements are intended to enhance the usability of systems and equipment, reduce human error, enhance situational awareness and support safe and effective monitoring and control under normal and abnormal modes of operation.

3.2 Control station layout

3.2.1 Control stations are to provide sufficient space and access for the intended number of operators in the expected operating conditions.

3.2.2 Local control stations are to be positioned to minimise the risk of harm to the operator.

3.2.3 Controls, displays and indicators are to be both logically and physically grouped, according to their function.

3.2.4 Where a function may be accessed from more than one interface, the arrangement of displays and controls is to be consistent.

3.2.5 Frequently used controls and displays are to be within easy reach and visible to the operator from the normal working position.

3.2.6 Controls and displays used infrequently and which may be used in an emergency are to be clearly identifiable, clearly visible, easily accessible and positioned to allow safe operability.

3.2.7 The relationship of a control with a display is to be immediately apparent.

- 3.2.8 The relationship of controls and displays with the equipment under control is to be immediately apparent.
- 3.2.9 There is to be adequate spacing between controls and between controls and obstructions.
- 3.2.10 Controls and their associated displays are to be located such that the information on the displays can be easily read during the operation of the controls.
- 3.2.11 Indicators related to controls are to be visible during their operation.
- 3.2.12 Instruments are to face the operator's intended working position.

3.3 Physical environment

- 3.3.1 Control stations are to be positioned as far, as practicable, away from, or insulated against, sources of structurally transmitted vibration and noise, such as ventilation fans, engine intake fans and other noise sources.
- 3.3.2 In general, noise levels are to comply with IMO Resolution MSC.337(91) – Adoption of the Code on Noise Levels on Board Ships – (Adopted on 30 November 2012)The Annex below is consolidated into Noise Levels - Code on Noise Levels on Board Ships (Resolution MSC.337(91)) , and take into account IMO Res. A.343(IX), Recommendation on Methods of Measuring Noise Levels at Listening Posts.
- 3.3.3 Where provided, the heating, ventilation and air conditioning system is to be capable of maintaining the temperature between 18°C and 27°C.
- 3.3.4 The flow of air from heating or air conditioning systems is not to be guided directly to the operator, or means are to be provided to adjust the direction of airflow from those systems.
- 3.3.5 Lighting is to be located to avoid glare from working and display surfaces, and is to be flicker-free. Surfaces are to have a non-reflective or matt finish.
- 3.3.6 Placement of controls, displays and indicators are to consider the position of light sources relative to the operator, with respect to reflections and evenness of lighting.
- 3.3.7 Where a transparent cover is fitted over a control, display or indicator, it is to be designed to minimise reflections.
- 3.3.8 The level of lighting is to be sufficient to enable operation of user interfaces. Lighting levels in accordance with Table 1.3.1 Specific lighting levels will be considered to satisfy this requirement.

Table 1.3.1 Specific lighting levels

Work area	Ideal Lux	Minimum Lux
General Lighting	540	220
Control room consoles (front)	540	320
Control room consoles (rear)	325	110
Local operating panels	540	320
Remote operating panels	540	320

- 3.3.9 Seating provided for use at control stations is to allow for varying height and/or reach needs of operators. Seating arrangements are to minimise the need for twisting and/or turning motions by the operator.
- 3.3.10 Physical hazards, e.g. sharp edges, protuberances and trip hazards, are to be avoided.
- 3.3.11 Sufficient handrails or equivalent are to be fitted to enable operators to move and stand safely in rough seas.
- 3.3.12 Work surfaces are to be capable of withstanding oils and solvents common to ships and are to be easy to clean.

3.4 Operator interface

- 3.4.1 The design of the operator interface is to permit the satisfactory monitoring, control and supervision of the machinery and equipment.

3.4.2 Information is to be presented to the operator consistently, both within and between different interfaces, see *Pt 6, Ch 1, 3.6 Displays 3.6.2 to Pt 6, Ch 1, 3.6 Displays 3.6.4*.

3.4.3 The response of the machinery and equipment to operator input is to be consistent between interfaces for the same function.

3.4.4 Visual, audible or mechanical feedback is to be provided to indicate that operator input has been acknowledged.

3.4.5 Functions requested by the operator are to be confirmed by the displays on completion.

3.4.6 Indications and documentation are to be in English or the language of the crew.

3.5 Controls

3.5.1 Operator inputs are to be checked for errors, for example, out of range data or incorrect actions, and the operator is to be alerted when they occur.

3.5.2 Means are to be provided to correct wrong inputs or commands rapidly and safely.

3.5.3 Assistance is to be provided to the operator to recover from operator errors, for example, through advisory screens where the automation system has this facility.

3.5.4 Operator confirmation is to be provided for any control action that could affect the safety of the ship, i.e. they should not rely on single keystrokes.

3.5.5 The purpose of each control is to be clearly indicated. Where standard symbols have been internationally adopted, they should be used.

3.5.6 The settings of mechanical controls are to be immediately evident.

3.5.7 The means of operation of mechanical controls is to be consistent with expectations.

3.5.8 Controls or combined controls and indicators are to be distinguishable from indicators.

3.5.9 Where control is provided by touch screens, the soft keys are to be of a sufficient size for operation in areas where vibration occurs or gloves are likely to be worn.

3.5.10 Where virtual keypads/keyboards or dialogue boxes are used on touch screens, they are not to obscure status or alarm areas of the display.

3.5.11 Keyboards are to be divided logically into functional areas. Alphanumeric, paging and specific system keys are to be grouped separately.

3.5.12 Controls that affect the safe operation of the ship should be arranged so as to minimise the possibility of inadvertent operation.

3.6 Displays

3.6.1 The displays and indicators are to present the operator with clear, timely and relevant information.

3.6.2 Graphical symbols and colour coding are to be consistent. The graphical symbols of display functions are to be in accordance with a recognised International Standard, for example, ISO 14617 (all parts): *Graphical symbols for diagrams*. Colour coding of functions and signals is to be in accordance with a recognised International Standard, for example, ISO 2412: *Shipbuilding – Colours of indicator lights*.

3.6.3 The symbols used in mimic diagrams for the services listed in *Pt 6, Ch 2, 1.6 Definitions 1.6.1* are to be consistent across all displays.

3.6.4 The display of information is to be consistent with respect to screen layout and arrangement of information.

3.6.5 Flashing of information is to be reserved for unacknowledged alerts or transient states, for example, valve moving.

3.6.6 The functions supported by a display are to be clearly indicated. For displays that can support multiple functions, it is to be possible to select the display associated with the primary function or an overview by a simple operator action.

3.6.7 The operating mode of the machinery and equipment is to be clearly indicated.

3.6.8 In general, indications provided by instrumentation which are displayed digitally are not to change more frequently than twice per second.

-
- 3.6.9 To indicate an increasing value in a single direction, on a fixed circular scale, the pointer is to move clockwise. If the pointer is fixed, the scale is to move anticlockwise to indicate an increase in value.
- 3.6.10 To indicate an increasing value on a horizontal linear scale, the pointer is to move from left to right. On a vertical linear scale, the pointer is to move upwards to indicate an increase in value.
- 3.6.11 The pointer is not to obscure the numbers on the scale.
- 3.6.12 Alphanumeric data, text, symbols and other graphical information is to be readable from relevant operator positions under lighting conditions, as specified in *Pt 6, Ch 1, 3.3 Physical environment 3.3.8*. Character height in millimetres is to be not less than three and a half times the reading distance in metres and character width is to be 0,7 times the character height.
- 3.6.13 A simple sans-serif character font is to be used in displays. In descriptive text, lower case letters are to be used, where appropriate, as opposed to capitals, to improve readability.
- 3.6.14 Where information related to the safe operation of machinery and equipment is provided, it is to be continuously available to the operator.
- 3.6.15 Failures are to be indicated in a clear and unambiguous manner. Sufficient information is to be provided for the operator to identify the cause of the failure.
-

■ *Section 4* **Unattended machinery space(s) - UMS notation**

4.1 General

4.1.1 Where it is proposed to operate the following machinery in an unattended space, no matter what period is envisaged, the controls, alarms and safeguards required by *Pt 5 Main and Auxiliary Machinery*, together with those given in *Pt 6, Ch 1, 4.2 Alarm system for machinery* are to be provided:

- (a) Air compressors.
- (b) Controllable pitch propellers and transverse thrust units.
- (c) Electric generating plant.
- (d) Inert gas generators.
- (e) Incinerators.
- (f) Main propelling machinery including essential auxiliaries.
- (g) Fuel oil transfer and storage systems (purifiers and oil heaters).
- (h) Steam raising plant (boilers and their ancillary equipment).
- (i) Thermal fluid heaters.
- (j) Waste heat boilers.

4.2 Alarm system for machinery

4.2.1 An alarm system which will provide warning of faults in the machinery is to be installed. The system is to satisfy the requirements of *Pt 6, Ch 1, 2.3 Alarm systems, general requirements*.

4.2.2 Audible and visual indication of machinery alarms is to be relayed to the engineers' accommodation so that engineering personnel are made aware that a fault has occurred.

4.2.3 The engineers' alarm required by *Pt 6, Ch 1, 2.2 Control stations for machinery 2.2.4* is to be activated automatically in the event that a machinery alarm or warning has not been acknowledged in the space within a predetermined time.

4.2.4 Audible and visual indication of machinery alarms is to be relayed to the navigating bridge control station in such a way that the navigating officer of the watch is made aware when:

- (a) a machinery fault has occurred;
- (b) the machinery fault is being attended to; and
- (c) the machinery fault has been rectified.

Alternative means of communication between the bridge area, accommodation for engineering personnel and machinery spaces will be considered.

4.2.5 Group alarms may be arranged on the bridge to indicate machinery faults, but alarms associated with faults requiring speed or power reduction or the automatic shutdown of propulsion machinery are to be identified by separate group alarms or by individual alarms.

4.3 Bridge control for main propulsion machinery

4.3.1 A bridge control system for the main propulsion machinery is to be fitted. The system is to satisfy the requirements of *Pt 6, Ch 1, 2.6 Bridge control for main propulsion machinery*.

4.4 Control stations for machinery

4.4.1 A control station(s) is to be provided in the space and on the bridge which satisfies the requirements of *Pt 6, Ch 1, 2.2 Control stations for machinery*.

4.5 Fire detection alarm system

4.5.1 An automatic fire detection system is to be fitted in the space together with an audible and visual alarm system. The system is to satisfy the requirements of *Pt 6, Ch 1, 2.8 Fire detection alarm systems*.

4.6 Bilge level detection

4.6.1 An alarm system is to be provided to warn when liquid in machinery space bilges has reached a predetermined level, and is to comply with *Pt 6, Ch 1, 2.3 Alarm systems, general requirements*. This level is to be sufficiently low to prevent liquid from overflowing from the bilges onto the tank top. The number and location of detectors are to be such that accumulation of liquids will be detected at all angles of heel and trim. In ships above 2000 gross tons there are to be two independent systems of bilge level detection in the machinery space, arranged such that each branch bilge as required by *Pt 5, Ch 13 Ship Piping Systems* is provided with a level detector.

4.6.2 Local or remote controls of any valve within the space serving a sea inlet, a discharge below the waterline, a bilge injection or a direct bilge system, should be so sited as to be readily accessible and to allow adequate time for operation in case of influx of water to the space, having regard to the time which could be taken to reach and operate such controls; *see also Pt 6, Ch 1, 2.7 Valve control systems and Pt 5, Ch 13, 2 Construction and installation and Pt 5, Ch 13, 4 Bilge drainage of machinery spaces*.

4.6.3 Where the bilge pumps are arranged to start automatically, means are to be provided to indicate if the influx of liquids is greater than the pump capacity or, if the pump is operating more frequently than would be expected. Special attention should be given to oil pollution prevention requirements.

4.7 Supply of electric power, general

4.7.1 For ships operating with one generator set in service, arrangements are to be such that a standby generator will automatically start and connect to the switchboard in as short a time as practicable, but in any case within 45 seconds, on loss of the service generator. For ships operating with two or more generator sets in service, arrangements are to be such that on loss of one generator the remaining one(s) are to be adequate for continuity of essential services. For the detailed requirements of these arrangements, *see Pt 6, Ch 2, 2.2 Number and rating of generators and converting equipment*.

■ *Section 5*

Machinery operated from a centralised control station - CCS notation

5.1 General requirements

5.1.1 Where it is proposed to operate the machinery as listed in *Pt 6, Ch 1, 4.1 General 4.1.1* with the continuous supervision from a centralised control station, the control station is to be such that the machinery operation will be as effective as it would be under direct supervision.

5.1.2 The arrangements are to be such that corrective actions can be taken at the control station in the event of machinery faults, e.g. stopping of machinery, starting of standby machinery, adjustment of operating parameters, etc. These actions may be effected by either remote manual or automatic control.

5.1.3 The controls, alarms and safeguards required by *Pt 6, Ch 1, 3 Ergonomics of control stations* and by *Pt 6, Ch 1, 4.6 Bilge level detection* together with a fire detection system satisfying the requirements of *Pt 6, Ch 1, 2.8 Fire detection alarm systems* are to be provided. However, the automatic operation of machinery and certain safeguards required by *Pt 6, Ch 1, 3 Ergonomics of control stations* may be omitted.

5.1.4 Additional requirements for controls, alarms and safeguards are given in *Pt 6, Ch 1, 5.2 Centralised control station for machinery*.

5.2 Centralised control station for machinery

5.2.1 A centralised control station which satisfies the requirements of *Pt 6, Ch 1, 5.2 Centralised control station for machinery 5.2.2* to *Pt 6, Ch 1, 5.2 Centralised control station for machinery 5.2.7* is to be provided at a suitable location.

5.2.2 A system of alarm displays and controls is to be provided which readily ensures identification of faults in the machinery and satisfactory supervision of related equipment. The alarm and control systems are to satisfy the requirements of *Pt 6, Ch 1, 2.3 Alarm systems, general requirements* and *Pt 6, Ch 1, 2.5 Control systems, general requirements*, as applicable.

5.2.3 Indication of all essential parameters necessary for the safe and effective operation of the machinery is to be provided, e.g. temperatures, pressures, tank levels, speeds, powers, etc.

5.2.4 Indication of the operational status of running and standby machinery is to be provided.

5.2.5 At the centralised control station, means of communication with the bridge area, the accommodation for engineering personnel and, if necessary, the machinery space are to be provided.

5.2.6 In addition to the communication required by *Pt 6, Ch 1, 5.2 Centralised control station for machinery 5.2.5*, a second means of communication is to be provided between the bridge and the centralised control station. One of these means is to be independent of the main electrical power supply, see also *Pt 5, Ch 1 General Requirements for the Design and Construction of Machinery*.

5.2.7 Arrangements are to be provided in the centralised control station so that the normal supply of electrical power may be restored in the event of failure.

■ **Section 6** **Integrated computer control - ICC notation**

6.1 General

6.1.1 Integrated Computer Control class notation **ICC** may be assigned where an integrated computer system in compliance with *Pt 6, Ch 1, 6.1 General* provides fault tolerant control and monitoring functions for one or more of the following services:

- (a) Propulsion;
- (b) Electrical generation and distribution (power management systems);
- (c) Cargo and ballast.

6.1.2 A Failure Mode and Effects Analysis (FMEA) is to be carried out in accordance with IEC 60812: *Analysis techniques for system reliability – Procedure for failure mode and effects analysis (FMEA)* and the report and worksheets submitted for consideration. See also *Pt 6, Ch 1, 2.14 Programmable electronic systems – Additional requirements for integrated systems 2.14.5*. The FMEA is to demonstrate that control and monitoring functions required by *Pt 6, Ch 1, 6.2 General requirements* will remain available at each operator station in the event of a single fault of the integrated computer control system, including input error, without adverse effect on the service(s).

6.1.3 Special consideration will be given to integrated computer control systems for other applications, except where these are addressed by other control engineering class notations. In particular, see *Pt 7, Ch 9 Navigational Arrangements and Integrated Bridge Systems* for requirements of the optional class notation **IBS** – Integrated Bridge Navigation Systems.

6.2 General requirements

6.2.1 The integrated computer control system is to comply with the programmable electronic system requirements of *Pt 6, Ch 1, 2.10 Programmable electronic systems - General requirements* to *Pt 6, Ch 1, 2.13 Programmable electronic systems - Additional requirements for essential services and safety critical systems* and the control and monitoring requirements of the Rules applicable to particular equipment, machinery or systems.

6.2.2 Alarm displays are to be provided, in compliance with the requirements of *Pt 6, Ch 1, 2.3 Alarm systems, general requirements*, which ensure ready identification of faults in the equipment under control.

6.2.3 Alarm and indication functions required by *Pt 6, Ch 1, 2.4 Safety systems, general requirements* are to be provided by the integrated computer control system in response to the activation of any safety function for associated machinery. Systems providing the safety functions are in general to be independent of the integrated computer system. See also *Pt 6, Ch 1, 2.13 Programmable electronic systems - Additional requirements for essential services and safety critical systems 2.13.7*.

6.2.4 Controls are to be provided, in compliance with *Pt 6, Ch 1, 2.5 Control systems, general requirements*, to ensure the safe and effective operation of equipment and response to faults, e.g. stopping, starting, adjustment of parameters, etc. Indication of operational status and other such parameters necessary to satisfy this requirement, is to be provided for all equipment under control by the integrated computer control system.

6.3 Operator stations

6.3.1 Each operator station allowing control of equipment is to be provided with a minimum of two multi-function display and control units. The number of units is to be sufficient to allow simultaneous access to control and monitoring functions required by *Pt 6, Ch 1, 6.2 General requirements 6.2.2* to *Pt 6, Ch 1, 6.2 General requirements 6.2.4*. See also *Pt 6, Ch 1, 2.10 Programmable electronic systems - General requirements 2.10.10* to *Pt 6, Ch 1, 2.10 Programmable electronic systems - General requirements 2.10.16*.

6.3.2 Each multi-function display and control unit is to include a monitor, keyboard and tracker ball. Alternative arrangements will be considered where these enable each unit to be configured by the user to provide required control or monitoring functions.

6.3.3 Where the integrated computer control system is arranged such that control and monitoring functions may be accessed at more than one operator station, the selected mode of operation of each station (e.g. in control, standby, etc.) is to be clearly indicated. See also *Pt 6, Ch 1, 2.2 Control stations for machinery*.

6.3.4 Means of communication are to be provided between operator stations and any other stations from which the equipment may be controlled. The arrangements are to be permanently installed and are to remain operational in the event of failure of the main electrical power supply to the integrated control system.

■ Section 7**Trials****7.1 General**

7.1.1 Before a new installation (or any alteration or addition to an existing installation) is put into service, trials are to be carried out. These trials are in addition to any acceptance tests which may have been carried out at the manufacturers' works and are to be based on the approved test schedules list as required by *Pt 6, Ch 1, 1.2 Documentation required for design review 1.2.2*. In the case of new construction it will be expected that most of these trials will be carried out before the official sea trials of the ship. During sea trials, system dynamic tests are to be carried out to demonstrate overall satisfactory performance of the control engineering installation.

7.1.2 Means are to be provided to facilitate testing during normal machinery operation, e.g. by the provision of three-way test valves or equivalent.

7.1.3 Acceptance tests and trials for programmable electronic systems are to include verification of software lifecycle activities appropriate to the stage in the system's lifecycle at the time of system examination. The documentation required by *Pt 6, Ch 1, 1.2 Documentation required for design review 1.2.6* is to be in accordance with the current configuration and the testing and trials are to address software modifications and configuration management procedures to the Surveyor's satisfaction.

7.1.4 Wireless data communication links are to be operational and tested during trials. Tests are to demonstrate that radio-frequency transmission does not interfere with the operation of equipment required by this Chapter or other Sections of the Rules and does not itself malfunction as a result of electromagnetic interference during expected operating conditions. Reversionary modes are to be activated to demonstrate continued safe and effective operation in the event of fault conditions.

7.2 Unattended machinery space operation - UMS notation

7.2.1 In addition to the tests required by *Pt 6, Ch 1, 7.1 General* the suitability of the installation for operation in the unattended mode is to be demonstrated during sea trials over a four to six hour period observing the following:

- (a) Occurring alarms and the frequency of operation both during steady steaming and under manoeuvring conditions using bridge control.
- (b) Any intervention by personnel in the operation of the machinery.

7.3 Operation from a centralised control station - CCS notation

7.3.1 In addition to the tests required by *Pt 6, Ch 1, 7.1 General*, the suitability of the installation for operation from the centralised control station is to be demonstrated during sea trials.

7.4 Record of trials

7.4.1 Two copies of the alarm and control equipment test schedules signed by the Surveyor and Builder are to be provided on completion of the survey. One copy is to be placed on board the vessel and the other submitted to LR.

Section

-
- 1 **General requirements**
 - 2 **Main source of electrical power**
 - 3 **Emergency source of electrical power**
 - 4 **External source of electrical power**
 - 5 **Supply and distribution**
 - 6 **System design – Protection**
 - 7 **Switchgear and controlgear assemblies**
 - 8 **Protection from electric arc hazards within electrical equipment**
 - 9 **Rotating machines**
 - 10 **Converter equipment**
 - 11 **Electric cables, optical fibre cables and busbar trunking systems (busways)**
 - 12 **Batteries**
 - 13 **Equipment - Heating, lighting and accessories**
 - 14 **Electrical equipment for use in explosive gas atmospheres or in the presence of combustible dusts**
 - 15 **Navigation and manoeuvring systems**
 - 16 **Electric propulsion**
 - 17 **Fire safety systems**
 - 18 **Crew and passenger emergency safety systems**
 - 19 **Ship safety systems**
 - 20 **Lightning conductors**
 - 21 **Testing and trials**
 - 22 **Spare gear**
 - 23 **Ergonomic Lighting Design – ELD optional notation**
-

■ *Section 1*
General requirements

1.1 General

1.1.1 The requirements of this Chapter apply to passenger ships and cargo ships except where otherwise stated.

1.1.2 Whilst these requirements are considered to meet those of the *SOLAS - International Convention for the Safety of Life at Sea*, and applicable amendments, attention should also be given to any relevant Statutory Regulations of the National Administration of the country in which the ship is to be registered. Compliance with the Statutory Regulations of the National Administration may be accepted as meeting the requirements of the *International Convention for the Safety of Life at Sea, 1974*, and applicable amendments.

1.1.3 Electrical services required to maintain the ship in a normal sea-going, operational and habitable condition are to be capable of being maintained without recourse to the emergency source of electrical power.

1.1.4 Electrical services essential for safety are to be maintained under declared normal and reasonably foreseeable abnormal conditions.

1.1.5 The safety of passengers, crew and ship from electrical hazards is to be ensured.

1.1.6 Electrical installations on passenger ships having a length of 120 m or more or having three or more main vertical zones (see *Pt 5, Ch 23, 1.2 Definitions 1.2.4* for definitions) are, in addition to the requirements of this Chapter, to be located, designed and arranged to comply with *Pt 5, Ch 23 Safe Return to Port and Orderly Evacuation and Abandonment in Passenger Ships*, as applicable.

1.1.7 Lloyd's Register (hereinafter referred to as 'LR') will be prepared to give consideration to special cases or to arrangements which are equivalent to the Rules. For unconventional designs, see also *Pt 7, Ch 15 Refrigeration Systems and Equipment Serving Provision Stores and Air-Conditioning Installations*. Consideration will also be given to electrical arrangements of small ships and ships to be assigned class notation for restricted or special services.

1.2 Documentation required for design review

1.2.1 The documentation described in *Pt 6, Ch 2, 1.2 Documentation required for design review 1.2.2* to *Pt 6, Ch 2, 1.2 Documentation required for design review 1.2.15* is to be submitted for design review.

1.2.2 Single line diagrams of main, emergency and transitional power and lighting systems which are to include:

- (a) ratings of machines, transformers, batteries and semiconductor converters;
- (b) all feeders connected to the main and emergency switchboards;
- (c) section boards and distribution boards;
- (d) insulation type, size and current loadings of cables;
- (e) make, type and rating of circuit breakers and fuses;
- (f) details of harmonic filters (where fitted); and
- (g) details of power supply arrangements used for control systems.

1.2.3 A functional description of operation of the main, emergency and transitional electrical power systems, which is to include:

- (a) the operating philosophy of the main, emergency and transitional electrical power systems under normal and reasonably foreseeable abnormal conditions;
- (b) degraded modes of operation;
- (c) load management and load sharing philosophy; and
- (d) protection philosophy.

1.2.4 An earthing philosophy document that defines the basic approach to be taken for earthing the electrical power systems and all electrical loads.

1.2.5 Simplified diagrams of generator circuits, inter-connector circuits and feeder circuits showing:

- (a) protective devices, e.g. short-circuit, overload, reverse power protection;
- (b) instrumentation and synchronising devices;
- (c) preference tripping;
- (d) remote stops and fire safety stops; and
- (e) earth fault indication/protection.

1.2.6 Calculations of short-circuit currents at main, emergency and transitional switchboards and section boards including those fed from transformers, details of circuitbreaker and fuse operating times and discrimination curves showing compliance with *Pt 6, Ch 2, 6.1 General* and *Pt 6, Ch 2, 11.6 Conductor size 11.6.2*.

1.2.7 Where required by *Pt 6, Ch 2, 8.1 General 8.1.1*, the hazards resulting from electric arcs within electrical equipment and their consequences for personnel are to be identified, and at least the following supporting evidence is to be submitted:

- (a) system design;
- (b) operating philosophies, e.g. manual or automatic control, local or remote operation;
- (c) general arrangement plans for switchboards, section boards and distribution boards, see also *Pt 6, Ch 2, 1.3 Documentation required for supporting evidence 1.3.4*;
- (d) general arrangement plans for the space in which the electrical equipment to be assessed are located showing:

- (i) access to adjacent spaces;
 - (ii) the location of the electrical equipment;
 - (iii) ventilation arrangements for air conditioning and/or the extraction of smoke, gas and vapours resulting from electric arcs; and
 - (iv) positions within the space in which the electrical equipment is located where personnel will be performing tasks, e.g. switching, equipment maintenance, instrument observation or cleaning, or where personnel could reasonably be expected to enter;
- (e) calculations in accordance with *Pt 6, Ch 2, 8.3 Calculations to be submitted*;
- (f) system operating procedures; and
- (g) details of defined additional safety measures to be taken during activities.

1.2.8 For ships in which explosive gas atmospheres and/or combustible dusts occur, a general arrangement of the ship showing hazardous zones and spaces, as defined within *Pt 6, Ch 2, 14 Electrical equipment for use in explosive gas atmospheres or in the presence of combustible dusts*, is to be submitted. Where the explosive gas or combustible dust is not associated with the ship's cargo, arrangement drawings for the hazardous locations only may be submitted in place of the complete ship general arrangement.

1.2.9 A schedule of electrical equipment for use in explosive gas atmospheres or in the presence of combustible dusts giving details, as appropriate, of:

- (a) type of equipment;
- (b) type of protection, e.g. Ex 'd';
- (c) apparatus group, e.g. IIB;
- (d) temperature class, e.g. T3;
- (e) enclosure ingress protection, e.g. IP55;
- (f) certifying authority;
- (g) certificate number;
- (h) location of equipment.

Details may be included on arrangement drawings for the hazardous locations, in place of a separate schedule. Where uncertified equipment is permitted by *Pt 6, Ch 2, 14.2 Selection of equipment for use in explosive gas atmospheres* or *Pt 6, Ch 2, 14.3 Selection of equipment for use in the presence of combustible dusts* or the Rules relevant to the specific type of ship, details of other documentation confirming *Pt 6, Ch 2, 1.2 Documentation required for design review 1.2.9* to *Pt 6, Ch 2, 1.2 Documentation required for design review 1.2.9* may be submitted in place of those listed under *Pt 6, Ch 2, 1.2 Documentation required for design review 1.2.9* and *Pt 6, Ch 2, 1.2 Documentation required for design review 1.2.9*.

1.2.10 For ships with electrical propulsion systems, a functional description is to be provided which includes:

- (a) the operating philosophy of the propulsion control systems under normal and reasonably foreseeable abnormal operating conditions;
- (b) degraded modes of operation;
- (c) protection philosophy;
- (d) earthing philosophy; and
- (e) harmonic analysis, including loss of harmonic filters. *See also Pt 6, Ch 2, 1.8 Quality of power supplies 1.8.3.*

1.2.11 Simplified circuit diagram of electrical propulsion system (where fitted) giving details of:

- (a) ratings of electrical machines, transformers, batteries, harmonic filters, dynamic braking assemblies and semiconductor converters;
- (b) lubrication and cooling arrangements, where provided;
- (c) insulation type, size and current loadings of cables;
- (d) make, type and rating of circuit-breakers and fuses;
- (e) instrumentation and protective devices;
- (f) earth fault indication/protection;
- (g) propulsion control systems, and the procedures used to ensure that there is satisfactory control of the design in relation to the requirements of *Pt 6, Ch 2, 16.4 Propulsion control*; and
- (h) harmonic analysis.

1.2.12 Details of electrically-operated fire, ship, crew and passenger emergency safety systems which are to include typical single line diagrams and arrangements, showing main vertical and, where applicable, horizontal fire zones, spaces along the ship bottom that are not fitted with a double bottom and the location of equipment and cable routes, including identification of relevant high fire risk areas, to be employed for:

- (a) emergency lighting;
- (b) accommodation fire detection, alarm and extinction systems;
- (c) fixed water-based local application fire-fighting systems;
- (d) public address system;
- (e) general emergency alarm;
- (f) watertight doors, bow, stern and shell doors and other electrically operated closing appliances; and
- (g) low location lighting.

Note A general arrangement plan of the complete ship showing the main vertical fire zones, spaces along the ship bottom that are not fitted with a double bottom and the location of equipment and cable routes, including identification of relevant high fire risk areas, for the above systems, is to be made available for the use of the Surveyor on board.

1.2.13 Evidence of the suitability of electrical and electronic equipment for use in protected areas and adjacent areas, as required by *Pt 6, Ch 2, 17.3 Fixed water-based local application fire-fighting systems 17.3.9* and *Pt 6, Ch 2, 17.3 Fixed water-based local application fire-fighting systems 17.3.10*, including a schedule of electrical and electronic equipment located in protected areas and adjacent areas, and general arrangement plans showing the coverage of the protected areas and adjacent areas. See also *Pt 6, Ch 2, 1.11 Location and construction*.

1.2.14 For battery installations, arrangement plans and calculations are to show compliance with *Pt 6, Ch 2, 12.5 Ventilation*.

1.2.15 A schedule of batteries fitted for use for emergency and essential services, giving details of:

- type and manufacturer's type designation;
- voltage and ampere-hour rating;
- location;
- equipment and/or system(s) served;
- maintenance/replacement cycle dates;
- date(s) of maintenance and/or replacement; and
- for replacement batteries in storage, the date of manufacture and shelf life; with accompanying battery replacement procedure documentation to show compliance with *Pt 6, Ch 2, 12.7 Recording of batteries for emergency and essential services*.

Note The above includes all batteries fitted as part of an uninterruptible power system (UPS) used for any essential or emergency services.

1.2.16 For high voltage rotating machines, type test reports for stator insulation systems, see *Pt 6, Ch 2, 9.1 General requirements 9.1.14*.

1.3 Documentation required for supporting evidence

1.3.1 The documentation and particulars in *Pt 6, Ch 2, 1.3 Documentation required for supporting evidence 1.3.2* to *Pt 6, Ch 2, 1.3 Documentation required for supporting evidence 1.3.5* are to be submitted as supporting evidence.

1.3.2 Plans for all cables that pass through atria or equivalent spaces, and for vertical runs in trunks or other restricted spaces. The information supplied is to show compliance with *Pt 6, Ch 2, 11.8 Installation of electric cables 11.8.10*.

1.3.3 In order to establish compliance with *Pt 6, Ch 2, 1.11 Location and construction 1.11.2* and *Pt 6, Ch 2, 5.1 Systems of supply and distribution 5.1.4*, a general arrangement plan of the ship showing the location of major items of electrical equipment, for example:

- main and emergency generators;
- transitional source of supply (where fitted);
- switchboards;
- section boards and distribution boards supplying essential and emergency services;
- emergency batteries;
- motors for emergency services;

- propulsion motors;
- propulsion transformers;
- propulsion semiconductor converters;
- dynamic braking equipment;
- reactors;
- harmonic filters; and
- cable routes between these items of equipment.

1.3.4 Arrangement plans of main and emergency switchboards, section boards and documentation that demonstrates that creepage and clearance distances are in accordance with *Pt 6, Ch 2, 7.5 Creepage and clearance distances*. The form factor of internal separation of low voltage switchgear and controlgear assemblies is to be in accordance with IEC 61439-2: *Low-voltage switchgear and controlgear assemblies – Part 2: Power switchgear and controlgear assemblies*, or an alternative acceptable and relevant national Standard. The form factor is to be stated, and the arrangement plans are to show how the form factor has been achieved.

1.3.5 Schedule of normal and emergency operating loads on the system estimated for the different operating conditions expected. The following details are to be provided to meet this requirement:

- (a) a description of the expected operating profiles (e.g. the number of generating sets connected when manoeuvring at sea, etc.), including that required by *Table 2.1.1 Plans and particulars to be submitted for appraisal*; and
- (b) a schedule of the normal and emergency operating loads, which is to state the kilowatt rating of each load and a load factor between 0 and 1 that reflects:
 - (i) the duty cycle of the load; and
 - (ii) the proportion of its maximum rating at which the load is expected to operate.

1.3.6 In order to establish compliance with the requirements of *Pt 6, Ch 2, 1.7 Design and construction 1.7.3*, when requested, evidence is to be submitted to demonstrate the suitability of electrical equipment for its intended purpose in the conditions in which it is expected to operate.

1.3.7 For non-metallic cable support systems or protective casings, test evidence, details of installation procedures and manufacturer's recommendations that show compliance with *Pt 6, Ch 2, 11.13 Non-metallic cable support systems, protective casings and fixings*.

1.3.8 Details of, and arrangements in, the spaces in which the lighting is required to satisfy the requirements of *Pt 6, Ch 2, 23 Ergonomic Lighting Design – ELD optional notation* Ergonomic Lighting Design (ELD) optional notation.

1.4 Surveys

1.4.1 Electrical propelling machinery and associated equipment together with auxiliary services essential for the safety of the ship are to be installed in accordance with the relevant requirements of this Chapter, surveyed and have tests witnessed by the Surveyors.

1.4.2 The following equipment, where intended for use for essential and emergency services, is to be surveyed by the Surveyors during manufacture and testing:

- Converting equipment of 100 kW and over;
- Rotating machines of 100 kW and over;
- Switchboards and section boards; and
- UPS units of 50 kVA and over.

1.4.3 For electric propulsion systems, in addition to the equipment listed in *Pt 6, Ch 2, 1.4 Surveys 1.4.2*, the following equipment is to be surveyed by the Surveyors during manufacture and testing:

- dynamic braking assemblies, see *Pt 6, Ch 2, 16.5 Protection of propulsion system 16.5.8*;
- exciters;
- filters;
- reactors;
- pre-magnetisation transformers; and
- slip ring assemblies.

1.4.4 For refrigerating cargo installations having an **RMC** notation, motors are to be tested and certificates furnished by the manufacturer. Motors of 100 kW or over are to be surveyed by the Surveyors during manufacture and testing.

1.4.5 All other electrical equipment, not specifically referenced in *Pt 6, Ch 2, 1.4 Surveys 1.4.2 to Pt 6, Ch 2, 1.4 Surveys 1.4.4*, intended for use for essential or emergency services is to be supplied with a manufacturer's works test certificate showing compliance with the constructional Standard(s) as referenced by the relevant requirements of this Chapter.

1.5 Additions or alterations

1.5.1 No addition, temporary or permanent, is to be made to the approved load of an existing installation until it has been ascertained that the current carrying capacity and the condition of the existing equipment including cables and switchgear are adequate for the increased load.

1.5.2 Plans are to be submitted for consideration, and the alterations or additions are to be carried out under the survey, and to the satisfaction of the Surveyors.

1.5.3 When it is proposed to replace permanently installed secondary valve-regulated sealed batteries with vented batteries, details are to be submitted for consideration to ensure continued safety in the presence of the products of electrolysis and evaporation being allowed to escape freely from the cells to the atmosphere. These details are to demonstrate that there will be adequate ventilation in accordance with *Pt 6, Ch 2, 12.5 Ventilation 12.5.9* and that the location and installation requirements of *Pt 6, Ch 2, 12.3 Location* and *Pt 6, Ch 2, 12.4 Installation* are complied with.

1.5.4 Proposed modifications to the electrical protection settings are to be developed in accordance with *Pt 6, Ch 2, 6.1 General 6.1.4* and plans submitted are also to address the updating of approved version of the details required by *Pt 6, Ch 2, 1.2 Documentation required for design review 1.2.5* and *Pt 6, Ch 2, 1.2 Documentation required for design review 1.2.6*.

1.5.5 Where it is intended to replace an existing incandescent lamp type navigation light with a light emitting diode type navigation light, details are to be submitted for consideration that demonstrate compliance with *Pt 6, Ch 2, 15.6 Navigation lights*. Light emitting diode type navigation lights failure detection arrangements are to satisfy the requirements of *Pt 6, Ch 2, 15.6 Navigation lights 15.6.5* and *Pt 6, Ch 2, 15.6 Navigation lights 15.6.6*.

1.6 Definitions

1.6.1 Essential services are those necessary for the propulsion and safety of the ship, such as the following:

- air compressors for oil engines;
- air pumps;
- automatic sprinkler systems;
- ballast pumps;
- bilge pumps;
- circulating and cooling water pumps;
- communication systems;
- condenser circulating pumps;
- electric propulsion equipment;
- electric starting systems for oil engines;
- extraction pumps;
- fans for forced draught to boilers;
- feed water pumps;
- fire detection and alarm systems;
- fuel valve cooling pumps;
- hydraulic pumps for controllable pitch propellers and those serving essential services here listed that would otherwise be directly electrically driven;
- lubricating oil pumps;
- inert gas fans and scrubber and deck seal pumps;
- lighting systems for those parts of the ship normally accessible to and used by personnel and passengers;
- liquefied gas cargo handling;
- navigational aids where required by Statutory Regulations;
- navigation lights and special purpose lights where required by Statutory Regulations;
- fuel oil pumps and fuel oil burning units;

- oil separators;
- pumps for fire-extinguishing systems;
- scavenge blowers;
- steering gear;
- thrusters for dynamic positioning;
- valves which are required to be remotely operated;
- ventilating fans for engine and boiler rooms;
- watertight doors, shell doors and other electrical operated closing appliances;
- windlasses;
- power sources and supply systems for supplying the above services; and
- steam raising plant, where steam is required for other essential services.

1.6.2 Services such as the following are considered necessary for minimum comfortable conditions of habitability:

- cooking;
- heating;
- domestic refrigeration;
- mechanical ventilation;
- sanitary and fresh water.

1.6.3 Services such as the following, which are additional to those in *Pt 6, Ch 2, 1.6 Definitions 1.6.1* and *Pt 6, Ch 2, 1.6 Definitions 1.6.2*, are considered necessary to maintain the ship in a normal sea-going operational and habitable condition:

- cargo handling and cargo care equipment;
- hotel services, other than those required for habitable conditions;
- thrusters, other than those for dynamic positioning.

1.6.4 A 'high voltage' is a voltage exceeding 1000 V a.c. or 1500 V d.c. between conductors, *see also Pt 6, Ch 2, 1.5 Additions or alterations 1.5.3*.

1.6.5 A 'switchboard' is a switchgear and controlgear assembly for the control of power generated by a source of electrical power and its distribution to electrical consumers.

1.6.6 A 'section board' is a switchgear and controlgear assembly for controlling the supply of electrical power from a switchboard and distributing it to other section boards, distribution boards or final sub-circuits.

1.6.7 A 'distribution board' is an assembly of one or more protective devices arranged for the distribution of electrical power to final sub-circuits.

1.6.8 A 'final sub-circuit' is that portion of a wiring system extending beyond the final overcurrent device of a board.

1.6.9 'Special category spaces' are those enclosed spaces above or below the bulkhead deck intended for the carriage of motor vehicles with fuel, for their own propulsion, in their tanks, into and from which such vehicles can be driven, and to which passengers have access. Special category spaces may be accommodated on more than one deck provided that the total overall clear height for vehicles does not exceed 10 m.

1.6.10 'Machinery spaces of Category A' are those spaces and trunks to such spaces which contain:

- (a) internal combustion machinery used for main propulsion; or
- (b) internal combustion machinery used for purposes other than main propulsion where such machinery has in the aggregate a total power output of not less than 375 kW; or
- (c) any oil-fired boiler or fuel oil unit.

1.6.11 'Dead ship condition' means that the entire machinery installation, including the power supply, is out of operation and that the auxiliary services for bringing the main propulsion systems into operation (e.g. compressed air, starting current from batteries, etc.) and for the restoration of the main power supply are not available. Means are to be available to start the emergency generator at all times, *see Pt 5, Ch 2, 9.4 Starting of the emergency source of power*.

1.6.12 Protected space is a machinery space where a fixed water-based local application fire-fighting system is installed.

1.6.13 Protected areas are areas within a protected space which are protected by a fixed water-based local application fire-fighting system.

1.6.14 Adjacent areas are areas, other than protected areas, exposed to direct spray or other areas where water may extend when a fixed water-based local application firefighting system is activated.

1.6.15 For emergency services and their emergency power supplies required to be capable of being operated under fire conditions, 'high fire risk areas' are:

- (a) machinery spaces, as defined by SOLAS 1974 as amended, *Chapter II-2 - Construction - Fire protection, fire detection and fire extinction*;
- (b) spaces containing fuel treatment equipment;
- (c) galleys and pantries containing cooking appliances;
- (d) laundries containing drying equipment;
- (e) hazardous zones and spaces; and
- (f) for passenger ships carrying more than 36 passengers:
 - (i) public spaces containing furniture and furnishings of other than restricted fire risk and having a deck area of 50 m² or more;
 - (ii) barber shops and beauty parlours; and
 - (iii) saunas.

Requests to exempt spaces identified in *Pt 6, Ch 2, 1.6 Definitions 1.6.15* may be considered when evidence is submitted that demonstrates emergency services will remain available in the event of a fire in the space (e.g. studies of fire protection measures, installation locations, system redundancy, etc.).

1.6.16 An 'electric arc' is an electrical discharge or a short-circuit through ionised air caused by isolation or insulation integrity failure.

1.6.17 'Incident energy' is the amount of energy impressed on a surface, a certain distance from the source, generated during an electric arc event.

1.7 Design and construction

1.7.1 Electrical propelling machinery and associated equipment together with equipment for services essential for the propulsion and safety of the ship are to be constructed in accordance with the relevant requirements of this Chapter.

1.7.2 The design and installation of other equipment is to be such that risk of fire due to its failure is minimised. It is, as a minimum, to comply with a National or International Standard revised where necessary for ambient conditions.

1.7.3 Electrical equipment is to be suitable for its intended purpose and accordingly, whenever practicable, be selected from the *List of Type Approved Products* published by LR. A copy of the Procedure for LR Type Approval System will be supplied on application.

1.7.4 For areas susceptible to deluge or submersion, cable entries are to prevent water ingress. In general, cable entries are to be in accordance with IEC 60092-101: *Electrical Installations in Ships – Part 101: Definitions and General Requirements*.

1.8 Quality of power supplies

1.8.1 All electrical equipment supplied from the main and emergency sources of electrical power and electrical equipment for essential and emergency services supplied from d.c. sources of electrical power is to be so designed and manufactured that it is capable of operating satisfactorily under normally occurring variations of voltage and frequency.

1.8.2 Unless specified otherwise, a.c. electrical equipment is to operate satisfactorily with the following simultaneous variations, from their nominal value, when measured at the consumer input terminals:

- (a) voltage:
 - permanent variations +6 per cent –10 per cent
 - transient variations due to step changes in load ± 20 per cent
 - recovery time 1,5 seconds
- (b) frequency:
 - permanent variations ± 5 per cent
 - transient variations due to step changes in load ± 10 per cent
 - recovery time 5 seconds
 - A maximum rate of change of frequency not exceeding $\pm 1,5$ Hz per second during cyclic frequency fluctuations.

1.8.3 **Harmonics.** Unless specified otherwise, the total harmonic distortion (THD) of the voltage waveform at any a.c. switchboard or section-board is not to exceed 8 per cent of the fundamental for all frequencies up to 50 times the supply frequency and no voltage at a frequency above 25 times supply frequency is to exceed 1,5 per cent of the fundamental of the supply voltage. THD is the ratio of the rms value of the harmonic content to the rms value of the fundamental, expressed in per cent and may be calculated using the expression:

$$THD = \frac{\sqrt{\sum_{h=2}^{\infty} V_h^2}}{V_1} \times 100$$

where

V_h = rms amplitude of a harmonic voltage of order h

V_1 = rms amplitude of the fundamental voltage.

1.8.4 Unless specified otherwise, d.c. electrical equipment is to operate satisfactorily with the following simultaneous variations from their nominal value, when measured at the consumer input terminals:

(a) When supplied by d.c. generator(s) or a rectified a.c. supply:

Voltage tolerance (continuous)	±10 per cent
Voltage cyclic variation deviation	5 per cent
Voltage ripple	10 per cent

(a.c. rms over steady state o.c. voltage)

(a) When supplied by batteries:

- (i) Equipment connected to the batteries during charging: Voltage tolerance +30 per cent, –25 per cent;
- (ii) Equipment not connected to batteries during charging: Voltage tolerance +20 per cent, –25 per cent.

Different voltage variations as determined by the charging/discharging characteristics, including ripple voltage from the charging device, may be considered. When battery chargers/battery combinations are used as d.c. power supply systems adequate measures are to be taken to keep the voltage within the specified limits during charging, boost charging and discharging of the battery.

1.9 Ambient reference and operating conditions

1.9.1 The rating for classification purposes of essential electrical equipment intended for installation in ships to be classed for unrestricted (geographical) service is to be based on an engine room ambient temperature of 45°C, and a sea-water temperature at the inlet of 32°C. The equipment manufacturer is not expected to provide simulated ambient reference conditions at a test bed.

1.9.2 In the case of a ship to be classed for restricted service, the rating is to be suitable for the ambient conditions associated with the geographical limits of the restricted service, see *Pt 1, Ch 2 Classification Regulations*.

1.9.3 Main and essential auxiliary machinery and equipment is to operate satisfactorily under the conditions shown in *Pt 5, Ch 1, 3.6 Ambient operating conditions*. Electrical equipment satisfying alternative ambient operating condition requirements for installation on ships contained in an acceptable and relevant National or International Standard may be considered to satisfy this requirement.

Note Details of local environmental conditions are stated in Annex B of IEC 60092-101-2002: *Electrical installations in ships – Part 101: Definitions and general requirements*.

1.9.4 Where electrical equipment is installed within environmentally controlled spaces, the ambient temperature for which the equipment is suitable for operation at its rated capacity may be reduced to a value not less than 35°C provided:

- the equipment is not for use for emergency services and is located outside of machinery space(s);
- temperature control is achieved by at least two cooling units so arranged that, in the event of loss of one cooling unit, for any reason, the remaining unit(s) will be capable of satisfactorily maintaining the design temperature;
- the equipment is able to be initially set to work safely within a 45°C ambient temperature until such a time that the lesser ambient temperature may be achieved; the cooling equipment is to be rated for an ambient temperature of not less than 45°C; and
- alarms are provided, at a continually attended control station, to indicate any malfunction of the cooling units.

See also Pt 6, Ch 1, 1.3 Control, alarm and safety equipment 1.3.3.

1.9.5 Where equipment is to comply with Pt 6, Ch 2, 1.9 Ambient reference and operating conditions 1.9.4, it is to be ensured that electrical cables for their entire length are adequately rated for the maximum ambient temperature to which they are exposed along their length.

1.9.6 Equipment used for cooling and maintaining the lesser ambient temperature in accordance with Pt 6, Ch 2, 1.9 Ambient reference and operating conditions 1.9.4 are considered essential services and are to satisfy the requirements of Pt 6, Ch 2, 5.2 Essential services.

1.10 Inclination of ship

1.10.1 Emergency and essential electrical equipment is to operate satisfactorily under the conditions as shown in Table 2.1.1 Inclination of ship.

1.10.2 In ships for the carriage of liquefied gas the emergency source of electrical power is also to remain operable under the conditions described in the Rules and Regulations for the Construction and Classification of Ships for the Carriage of Liquefied Gases in Bulk (hereinafter referred to as the Rules for Ships for Liquefied Gases), Electrical Installations. In ships for the carriage of liquid chemicals the emergency source of electrical power is also to remain operable under the conditions described in the Rules and Regulations for the Construction and Classification of Ships for the Carriage of Liquid Chemicals in Bulk (hereinafter referred to as the Rules for Ships for Liquid Chemicals), Ch 1, 10.1 General.

1.10.3 Any proposal to deviate from the angles given in Table 2.1.1 Inclination of ship will be specially considered taking into account the type, size and service of the ship.

Table 2.1.1 Inclination of ship

Installations, components	Angle of inclination, degrees, see Note 2			
	Athwartships		Fore-and-aft	dynamic
	static	dynamic	static	
Essential electrical equipment	15	22,5	5 see Note 3	7,5
Safety systems, e.g. emergency power installations, crew and passenger safety systems Switchgear, electrical and electronic appliances see Note 1	22,5	22,5	10	10

Note 1. Up to an angle of 45° no undesired switching operations or operational changes may occur.

Note 2. Athwartships and fore-and-aft inclinations may occur simultaneously.

Note 3. Where the length of the ship exceeds 100 m, the fore-and-aft static angle of inclination may be taken as:

$$\frac{500}{L} \text{ degrees}$$

where L = Rule length, in metres see Pt 3, Ch 1, 6.1 Principal particulars.

1.10.4 The dynamic angles of inclination in Table 2.1.1 Inclination of ship may be exceeded in certain circumstances dependent upon ship type and operation. The Shipbuilder is, therefore, to ensure that the electrical equipment is capable of operating under these angles of inclination.

1.11 Location and construction

1.11.1 All electrical equipment is to be constructed or selected, and installed such that:

- (a) live parts cannot be inadvertently touched, unless they are supplied at the safety voltage specified in Pt 6, Ch 2, 1.12 Earthing of non-current carrying parts 1.12.2;
- (b) it does not cause injury when handled or touched in the normal manner; and
- (c) it is unaffected by any water, steam or oil and oil vapour to which it is likely to be exposed.

Electrical equipment having, as a minimum, the degrees of protection as specified in IEC 60092-201: Electrical Installations In Ships – Part 201: System Design – General for the relevant location will satisfy these requirements.

1.11.2 Switchboards, section boards and distribution boards supplying essential and emergency services, as well as cables from the respective generators to and between these boards, are to be arranged to avoid areas of high fire risk and elevated temperatures, for example, in close proximity to incinerators and boilers.

1.11.3 Electrical equipment, as far as is practicable, is to be located:

- (a) such that it is accessible for the purpose of maintenance and survey;
- (b) clear of flammable material;
- (c) in spaces adequately ventilated to remove the waste heat liberated by the equipment under full load conditions, at the ambient conditions specified in *Pt 6, Ch 2, 1.9 Ambient reference and operating conditions*;
- (d) where flammable gases cannot accumulate. If this is not practicable, electrical equipment is to be of the appropriate 'safe-type', see *Pt 6, Ch 2, 14 Electrical equipment for use in explosive gas atmospheres or in the presence of combustible dusts*;
- (e) where it is not exposed to the risk of mechanical injury or damage from water, steam or oil.

1.11.4 Equipment design and the choice of materials are to reduce the likelihood of fire, ensuring that:

- (a) where the electrical energised part can cause ignition and fire, it is contained within the bounds of the enclosure of the electrotechnical product;
- (b) the design, material(s) and construction of the enclosure minimises, as far as is practicable, any internal ignition causing ignition of adjacent materials; and
- (c) where surfaces of the electrotechnical products can be exposed to external fire, they do not, as far as practicable, contribute to the fire growth.

Note Compliance with IEC 60695: *Fire hazard testing* (all parts), or an alternative and acceptable Standard, will satisfy this requirement.

1.11.5 Insulating materials and insulated windings are to be resistant to tracking, moisture, sea air, oil and oil vapour unless special precautions are taken to protect them.

1.11.6 The minimum creepage and clearance distances provided for electrical connections, terminals and similar bare live parts are to be in accordance with a relevant International or National Standard for the equipment or apparatus concerned. In cases where the rated voltage is outside that given in the Standard or where no Standard is available, the minimum creepage and clearance distances provided are to be in accordance with 7.5. Details of alternatives proposals including supporting design rationale and demonstration may be submitted for consideration.

1.11.7 Studs, screw-type or spring-type clamp terminations, satisfactory for the normal operating currents and voltages, are to be provided in electrical equipment for the connection of external cable, or busbar conductors, as appropriate, see also *Pt 6, Ch 2, 11.15 Electric cable ends*. There is to be adequate space and access for the terminations.

1.11.8 The design of equipment is to enable ease of access to all parts requiring inspection or replacement in service.

1.11.9 Equipment is not to remain alive through the control circuits and/or pilot lamps when switched off by the control switch. This does not apply to synchronising switches and/or plugs.

1.11.10 The operation of all electrical equipment and the lubrication arrangements are to be efficient under such conditions of vibration and shock as arise in normal practice.

1.11.11 All nuts, screws and clamping devices used in connection with current-carrying, supporting and working parts are to be provided with means to ensure that they cannot work loose by vibration and shock as arise in normal practice.

1.11.12 To allow ease of access, connectors are to be spaced far enough apart to permit connection and disconnection. At test points, adequate clearance is to be provided between connection points and controls to provide access for testing.

1.11.13 Conductors and equipment are to be placed at such a distance from the magnetic compasses, or are to be so disposed, that the interfering magnetic field is negligible when circuits are switched on and off.

1.11.14 Where electrical power is used for propulsion, the equipment is to be so arranged that it will operate satisfactorily in the event of partial flooding by bilge water above the tank top up to the bottom floor plate level, under the normal angles of inclination given in *Pt 6, Ch 2, 1.10 Inclination of ship* for essential electrical equipment, see *Pt 5, Ch 13 Ship Piping Systems*.

1.12 Earthing of non-current carrying parts

1.12.1 Except where exempted by *Pt 6, Ch 2, 1.12 Earthing of non-current carrying parts 1.12.2*, all non-current-carrying exposed metal parts of electrical equipment and cables are to be earthed for personal protection against electric shock.

1.12.2 The following parts may be exempted from the requirements of *Pt 6, Ch 2, 1.12 Earthing of non-current carrying parts 1.12.1*:

- (a) lamp-caps, where suitably shrouded;
- (b) shades, reflectors and guards supported on lampholders or light fittings constructed of, or shrouded in, non-conducting material;
- (c) metal parts on, or screws in or through, non-conducting materials, which are separated by such material from current-carrying parts and from earthed non-current carrying parts in such a way that in normal use they cannot become live or come into contact with earthed parts;
- (d) apparatus which is constructed in accordance with the principle of double insulation;
- (e) bearing housings which are insulated in order to prevent circulation of current in the bearings;
- (f) clips for fluorescent lamps;
- (g) cable clips and short lengths of pipes for cable protection;
- (h) apparatus supplied at a safety voltage not exceeding 50 V d.c. or 50 V a.c., between conductors, or between any conductor and earth in a circuit isolated from the supply. Autotransformers are not to be used for the purpose of achieving the alternating current voltage;
- (i) apparatus or parts of apparatus which although not shrouded in insulating material is nevertheless otherwise so guarded that it cannot be touched and cannot come in contact with exposed metal.

1.12.3 Where extraneous-conductive parts (i.e. parts not forming part of the electrical installation and liable to introduce an electric potential) are not bonded by separate earthing conductors, details are to be submitted that demonstrate that a permanent, metal-to-metal connection of negligible impedance, which will not degrade due to corrosion or vibration, will be achieved.

1.12.4 Armouring, braiding and other metal coverings of cables are to be effectively earthed. Where the armouring, braiding and other metal coverings are earthed at one end only, they are to be adequately protected and insulated at the unearthed end with the insulation being suitable for the maximum voltage that may be induced. See *Pt 6, Ch 2, 14.9 Cable and cable installation 14.9.3* for earthing of cables in hazardous zones or spaces.

1.12.5 The electrical continuity of all metal coverings of cables throughout the length of the cable, particularly at joints and tappings, is to be ensured.

1.12.6 Metal parts of portable appliances, other than current-carrying parts and parts exempted by *Pt 6, Ch 2, 1.12 Earthing of non-current carrying parts 1.12.2* are to be earthed by means of an earth-continuity conductor in the flexible cable or cord through the associated plug and socket-outlet.

1.12.7 Earthing conductors are to be of copper or other corrosion-resistant material and be securely installed and protected where necessary against damage and also, where necessary, against electrolytic corrosion. Connections are to be so secured that they cannot work loose under vibration.

1.12.8 The nominal cross-section areas of copper earthing conductors for electrical equipment are, in general to be equal to the cross-section of the current-carrying conductor up to 16 mm², with a minimum of 1,5 mm². Above this figure they are to be equal to at least half the cross-section of the current-carrying conductor with a minimum of 16 mm².

1.12.9 The nominal cross-section areas of copper earthing conductors for armouring, braiding and other metal coverings of cables are, in general, to be equal to the equivalent cross-section of the armouring, braiding and other metal coverings with a minimum of 1,5 mm².

1.12.10 Earthing conductors of materials other than copper are to have a conductance not less than that specified for an equivalent copper earthing conductor.

1.12.11 The connection of the earthing conductor to the hull of the ship is to be made in an accessible position, and is to be secured by a screw or stud of a diameter appropriate for the size of earthing conductor, but not less than 6 mm, which is to be used for this purpose only. Bright metallic surfaces at the contact areas are to be ensured immediately before the nut or screw is tightened and, where necessary, the joint is to be protected against electrolytic corrosion. The connection is to remain unpainted.

1.13 Bonding for the control of static electricity

1.13.1 Bonding straps for the control of static electricity are required for cargo tanks, process plant and piping systems, for flammable products and solids liable to release flammable gas and/or combustible dust, which are not permanently connected to the hull of the ship either directly or via their bolted or welded supports and where the resistance between them and the hull exceeds 1 M Ω .

1.13.2 Where bonding straps are required for the control of static electricity, they are to be robust, that is, having a cross-sectional area of at least 10 mm², and are to comply with *Pt 6, Ch 2, 1.12 Earthing of non-current carrying parts 1.12.7* and *Pt 6, Ch 2, 1.12 Earthing of non-current carrying parts 1.12.11*.

1.14 Alarms

1.14.1 Where alarms are required by this Chapter they are to be arranged in accordance with *Pt 6, Ch 1, 2.3 Alarm systems, general requirements*. Sound signal equipment, fire and general alarm bells are not required to be supplemented by visual indications, except in areas having high levels of background noise, such as machinery spaces.

1.14.2 The alarms in this Chapter are additional to those required by *Pt 6, Ch 1 Control Engineering Systems*. They may however form part of the alarm system that is required by *Pt 6, Ch 1 Control Engineering Systems*.

1.14.3 Cables for emergency alarms and their power sources are to be in accordance with *Pt 6, Ch 2, 1.16 Operation under fire conditions*.

1.14.4 Electrical equipment and cables for emergency alarms are to be so arranged that the loss of alarms in any one area due to localised fire, collision, flooding or similar damage is minimised, see *Pt 6, Ch 2, 1.16 Operation under fire conditions* and *Pt 6, Ch 2, 1.17 Operation under flooding conditions*.

1.14.5 Electric system: Alarms and safeguards are indicated in *Table 2.1.2 Electric system: Alarms and safeguards*.

Table 2.1.2 Electric system: Alarms and safeguards

Item	Alarm	Note
Busbar voltage	High and low	–
Busbar frequency	Low	–
Operation of load shedding	Warning	–
Generator cooling air temperature	High	For closed air circuit water-cooled machines

1.15 Labels, signs and notices

1.15.1 Labels, signs and notices required by this Chapter are to be positioned in clearly visible locations which will not be obscured.

1.15.2 Labels, signs and notices are to be easy to read under the expected operating conditions. Character height in accordance with *Table 2.1.3 Character height and viewing distance* will be considered to satisfy this requirement.

Table 2.1.3 Character height and viewing distance

Viewing distance (mm)	Minimum character height (mm)
Less than 500	2,3
500 – 1000	4,7
1000 – 2000	9,4
2000 – 4000	19
4000 – 8000	38

1.15.3 Controls, indicators and displays required by this Chapter are to be labelled to indicate their function. Labels are to be positioned in a manner that associates the label with the item being labelled.

1.15.4 Labels, signs and notices are to use short, clear messages. In general, warning signs and notices are to comprise:

- a signal word to convey the gravity of the risk (e.g. Danger, Warning or Caution);
- a statement of the nature and/or consequence of the hazard; and

- wherever practical, an instruction giving appropriate behaviour to avoid the hazard.

1.16 Operation under fire conditions

1.16.1 As a minimum, the following emergency services and their emergency power supplies, are required to be capable of being operated under fire conditions:

- Control and power systems to power-operated fire doors and status indication for all fire doors.
- Control and power systems to power-operated watertight doors and their status indication.
- Emergency lighting.
- Fire and general emergency alarms.
- Fire detection systems.
- Fire-extinguishing systems and fire-extinguishing media release alarms.
- Fire safety stops, *see also Pt 6, Ch 2, 17.6 Fire safety stops.*
- Low location lighting, *see also Pt 6, Ch 2, 18.4 Escape route or low location lighting (LLL) 18.4.3.*
- Public address systems.
- Emergency fire pump.

1.16.2 Where cables for the emergency services listed in *Pt 6, Ch 2, 1.16 Operation under fire conditions 1.16.1* pass through high fire risk areas, main vertical or horizontal fire zones other than those which they serve, they are to be so arranged that a fire in any of these areas or zones does not affect the operation of the emergency service in any other area or zone. This may be achieved either by:

- cables being of a fire resistant type complying with *Pt 6, Ch 2, 11.5 Construction 11.5.3*, and at least extending from the main control/monitoring panel to the nearest local distribution panel serving the relevant area or zone; or
- there being at least two-loops/radial distributions run as widely apart as is practicable and so arranged that in the event of damage by fire at least one of the loops/radial distributions remains operational.

1.16.3 Where the cables for the power supplies for the emergency services listed in *Pt 6, Ch 2, 1.16 Operation under fire conditions 1.16.1* pass through high fire risk areas, main vertical or horizontal fire zones other than those which they serve, they are to be of a fire resistant type complying with *Pt 6, Ch 2, 11.5 Construction 11.5.3*, extending at least to the local distribution panel serving the relevant area or zone.

1.16.4 Fire resistant electrical cables for the emergency services listed in *Pt 6, Ch 2, 1.16 Operation under fire conditions 1.16.1*, including their power supplies, are to be run as directly as is practicable, having regard to any special installation requirements, for example those concerning minimum bend radii.

1.16.5 In addition to *Pt 6, Ch 2, 1.11 Location and construction 1.11.4*, materials used for electrical equipment, cables and accessories within passenger accommodation areas are not to be capable of producing excessive quantities of smoke and toxic products.

1.16.6 NOTE:

Compliance with IEC 60695: *Fire hazard testing (all parts)*, or an alternative and acceptable Standard, will satisfy this requirement.

1.17 Operation under flooding conditions

1.17.1 Flooding of spaces along the ship bottom that are not fitted with a double bottom is not to result in the loss of the ability to provide electrically operated fire, ship, crew and passenger emergency safety systems outside of the spaces.

1.17.2 Installation of electrical equipment necessary to provide fire, ship, crew and passenger emergency safety systems in spaces along the ship bottom not fitted with a double bottom is to be avoided, wherever practical. Where it is proposed to install electrical equipment, including cabling, necessary to provide fire, ship, crew and passenger emergency safety systems in such spaces, evidence is to be submitted to demonstrate that required emergency services will be available in other spaces in the event of flooding of the space not fitted with a double bottom.

1.18 Protection of electrical equipment against the effects of lightning strikes

1.18.1 Precautions are to be taken to protect essential electronic equipment that may be susceptible to damage from voltage pulses attributable to the secondary effects of lightning. This may be achieved by suitable design and/or the use of additional protective devices, such as surge arrestors. Resultant induced voltages may be further reduced by the use of earthed metallic screened cables. *See also Pt 6, Ch 2, 19 Ship safety systems.*

1.19 Programmable electronic systems

1.19.1 Where programmable electronic systems are implemented and used to control the electrical installation, or to provide safety functions in accordance with the requirements of this Chapter (e.g. electric propulsion, circuit-breaker settings, switchgear and controlgear controllers, etc.), the arrangements are to satisfy the applicable requirements of *Pt 6, Ch 1, 2.10 Programmable electronic systems - General requirements* to *Pt 6, Ch 1, 2.13 Programmable electronic systems - Additional requirements for essential services and safety critical systems*.

1.19.2 Where *Pt 6, Ch 2, 1.19 Programmable electronic systems 1.19.1* applies, proposed modifications to software and acceptance testing and trials are to be in accordance with *Pt 6, Ch 1, 1.4 Alterations and additions* and *Pt 6, Ch 2, 7 Switchgear and controlgear assemblies* as applicable.

■ **Section 2**
Main source of electrical power

2.1 General

2.1.1 The main source of electrical power is to comply with the requirements of this Section and SOLAS Ch II-1, Part D, *Regulation 41 - Main source of electrical power and lighting systems* and *Regulation 42 - Emergency source of electrical power in passenger ships* without recourse to the emergency source of electrical power.

2.2 Number and rating of generators and converting equipment

2.2.1 Under sea-going conditions, the number and rating of service generating sets and converting sets, such as transformers and semi-conductor converters, when any one generating set or converting set is out of action, are:

- (a) to be in accordance with SOLAS Ch II-1, Part D, *Regulation 41 - Main source of electrical power and lighting systems*, Section 1.2 and to be sufficient to ensure operation of cargo refrigeration machinery of ships having an **RMC** notation and the container socket outlets and ventilation system of container ships having a **CRC** notation. See *Pt 6, Ch 2, 16.3 Power requirements 16.3.5* for electric propulsion systems;
- (b) to have sufficient reserve capacity to permit the starting of the largest motor without causing any motor to stall or any device to fail due to excessive voltage drop on the system;
- (c) to be capable of providing the electrical services necessary to start the main propulsion machinery from a dead ship condition in accordance with SOLAS Ch II-1, Part D, *Regulation 41 - Main source of electrical power and lighting systems*, Section 1.4.

2.2.2 The arrangement of the ship's main source of power is to be such that the operation of electrical services including cargo refrigeration machinery of ships having an RMC notation is to be in accordance with SOLAS Ch II-1, Part D *Regulation 41 - Main source of electrical power and lighting systems*, Section 1.3.

2.2.3 Where the electrical power requirement to maintain the ship in a normal operational and habitable condition is usually supplied by one generating set, arrangements are to be provided to prevent overloading of the running generator, see *Pt 6, Ch 2, 6.9 Load management*. On loss of power there is to be provision for automatic starting and connecting to the main switchboard of the standby set in as short a time as practicable, but in any case within 45 seconds, and automatic sequential restarting of essential services, see *Pt 6, Ch 2, 1.6 Definitions 1.6.1*, in as short a time as is practicable. In addition ships are to comply with SOLAS Ch II-1, Part D, *Regulation 41 - Main source of electrical power and lighting systems*, Section 5

Note Where the prime mover starting time will result in exceeding this starting and connection time, details are to be submitted for consideration.

2.3 Starting arrangements

2.3.1 The starting arrangements of the generating sets prime movers are to comply with the requirements of *Pt 5, Ch 2, 9 Starting arrangements* as applicable.

2.3.2 Where the emergency source of electrical power is required to be used to restore propulsion from a 'dead ship condition' it is to be in accordance with SOLAS Ch II-1, Part D, *Regulation 42 - Emergency source of electrical power in passenger ships*, Section 3.4, in addition to supplying those services in *Pt 6, Ch 2, 3.3 Emergency source of electrical power in passenger ships 3.3.1*, for passenger ships and *Pt 6, Ch 2, 3.4 Emergency source of electrical power in cargo ships 3.4.1* for cargo ships. See *Pt 5, Ch 2, 9.1 Dead ship condition starting arrangements 9.1.1* for dead ship condition starting arrangements.

2.4 Prime mover governors

2.4.1 The governing accuracy of the generating sets prime movers is to meet the requirements of *Pt 5, Ch 2, 7.3 Auxiliary engine governors*.

2.4.2 The maximum electrical step load switched on or off is not to cause the frequency variation of the electrical supply to exceed the parameters given in *Pt 6, Ch 2, 1.8 Quality of power supplies 1.8.2*.

2.5 Main propulsion driven generators not forming part of the main source of electrical power

2.5.1 Generators and generator systems having the ship's propulsion machinery as their prime mover but not forming part of the ship's main source of electrical power may be used whilst the ship is at sea to supply electrical services required for normal operational and habitable conditions provided that the requirements of *Pt 6, Ch 2, 2.5 Main propulsion driven generators not forming part of the main source of electrical power 2.5.2* to *Pt 6, Ch 2, 2.5 Main propulsion driven generators not forming part of the main source of electrical power 2.5.4* are satisfied.

2.5.2 Within the declared operating range of the generators and/or generator system, the specified voltage and frequency variations of the Rules are to be met.

2.5.3 Where there is remote control of the propulsion machinery, arrangements are to ensure that essential machinery power supplies are maintained during manoeuvring conditions in order to prevent a blackout situation.

2.5.4 In addition to the requirements of *Pt 6, Ch 2, 2.2 Number and rating of generators and converting equipment 2.2.3*, arrangements are to be fitted to automatically start one of the generators forming the main source of power should the frequency variations exceed those permitted by the Rules.

■ **Section 3**
Emergency source of electrical power

3.1 General

3.1.1 The requirements of this Section apply to passenger and cargo ships to be classed for unrestricted service. They do not apply to cargo ships of less than 500 tons gross tonnage.

3.1.2 For ships assigned a Service Restriction Notation in accordance with *Pt 1, Ch 2 Classification Regulations*, a lesser period than the 36 hour period and 18 hour period specified in *Pt 6, Ch 2, 3.3 Emergency source of electrical power in passenger ships* and *Pt 6, Ch 2, 3.4 Emergency source of electrical power in cargo ships* respectively may be considered, but not less than 12 hours.

3.1.3 The emergency source of power for cargo ships of less than 500 tons gross tonnage will be the subject of special consideration.

3.2 Emergency source of electrical power in all ship types

3.2.1 All ships are to comply with the requirements as described in SOLAS II-1, Part D, *Regulation 40 - General* and *Regulation 41 - Main source of electrical power and lighting systems* except where expressly provided.

3.2.2 Where compliance with *Pt 6, Ch 2, 3.2 Emergency source of electrical power in all ship types 3.2.1* is not practicable, details of the proposed design and arrangements are to be submitted for consideration in accordance with SOLAS II-1, Part D, *Regulation 45 - Precautions against shock, fire and other hazards of electrical origin (Paragraphs 10 and 11 of this regulation apply to ships constructed on or after 1 January 2007)*.

3.3 Emergency source of electrical power in passenger ships

3.3.1 Passenger ships are to comply with the requirements as described in SOLAS II-1, Part D, *Regulation 42 - Emergency source of electrical power in passenger ships* and *Regulation 42-1 - Supplementary emergency lighting for ro-ro passenger ships* as applicable.

3.3.2 In passenger ships, supplementary lighting is to be provided in all cabins to indicate clearly the exit so that occupants will be able to find their way to the door as described in SOLAS II-1, Part D, *Regulation 41 - Main source of electrical power and lighting systems*.

3.3.3 Where compliance with *Pt 6, Ch 2, 3.3 Emergency source of electrical power in passenger ships 3.3.1* and *Pt 6, Ch 2, 3.3 Emergency source of electrical power in passenger ships 3.3.2* is not practicable, details of the proposed design and arrangements are to be submitted for consideration in accordance with SOLAS II-1, Part D, *Regulation 45 - Precautions against shock, fire and other hazards of electrical origin (Paragraphs 10 and 11 of this regulation apply to ships constructed on or after 1 January 2007)*.

3.4 Emergency source of electrical power in cargo ships

3.4.1 Cargo ships are to comply with the requirements as described in SOLAS II-1, Part D, *Regulation 43 - Emergency source of electrical power in cargo ships*.

3.4.2 Where compliance with *Pt 6, Ch 2, 3.4 Emergency source of electrical power in cargo ships 3.4.1* is not practicable, details of the proposed design and arrangements are to be submitted for consideration in accordance with SOLAS II-1, Part D, *Regulation 45 - Precautions against shock, fire and other hazards of electrical origin (Paragraphs 10 and 11 of this regulation apply to ships constructed on or after 1 January 2007)*.

3.5 Starting arrangements

3.5.1 Where the emergency source of power is a generator, the starting arrangements are to comply with the requirements given in SOLAS II-1, Part D, *Regulation 44 - Starting arrangements for emergency generating sets*.

3.6 Prime mover governor

3.6.1 Where the emergency source of power is a generator, the governor is to comply with *Pt 6, Ch 2, 2.4 Prime mover governors*.

3.7 Sources of Energy for Radio installation

3.7.1 The sources of energy required for each radio installation as required by SOLAS 1974 as amended, Chapter IV, *Part C - Ship requirements*, are to comply with SOLAS 1974 as amended, Chapter IV, Part C, *Regulation 13 - Sources of energy*.

■ *Section 4* **External source of electrical power**

4.1 Temporary external supply

4.1.1 Where arrangements are made for the supply of electricity from a source on shore or elsewhere, a connection box is to be installed in a position suitable for the convenient reception of flexible cables from the external source and containing a circuit-breaker or isolating switch and fuses and terminals including one earthed, of ample size and suitable shape to facilitate a satisfactory connection of three-phase external supplies with earthed neutrals.

4.1.2 Suitable cables, permanently fixed, are to be provided, connecting the terminals in the connection box to a linked switch and/or a circuit-breaker at the main switchboard. An indicator is to be provided at the main switchboard in order to show when the cables are energised.

4.1.3 Means are to be provided for checking the phase sequence of the incoming supply.

4.1.4 At the connection box a notice is to be provided giving full information on the system of supply, the normal voltage and frequency of the installation's system and the procedure for carrying out the connection.

4.1.5 Alternative arrangements may be submitted for consideration. *See also Pt 7, Ch 13 On-shore Power Supplies* for class notation **OPS**.

4.2 Permanent external supply

4.2.1 Details are to be submitted.

■ Section 5 Supply and distribution

5.1 Systems of supply and distribution

5.1.1 The following systems of generation and distribution are acceptable, other than for tankers intended for the carriage in bulk of oil, liquefied gases and other hazardous liquids having a flash point not exceeding 60°C (closed-cup test):

- (a) d.c., two-wire,
- (b) a.c., single-phase, two-wire;
- (c) a.c., three-phase;
 - (i) three-wire;
 - (ii) four-wire with neutral solidly earthed but without hull return.

5.1.2 For tankers intended for the carriage in bulk of oil, liquefied gases and other hazardous liquids having a flash point not exceeding 60°C (closed-cup test) only the following systems of generation and distribution are acceptable:

- (a) d.c., two-wire, insulated;
- (b) a.c., single-phase, two-wire, insulated;
- (c) a.c., three-phase, three-wire, insulated;
- (d) earthed systems, a.c. or d.c., limited to areas outside any hazardous space or zone, and arranged so that no current arising from an earth-fault in any part of the system could pass through a hazardous space or zone;
- (e) earthed systems, complying with *Pt 6, Ch 2, 5.1 Systems of supply and distribution 5.1.1* and *Pt 6, Ch 2, 5.5 Earthed distribution systems 5.5.7*, provided the Government of the Flag State permits such an arrangement in accordance with the 'Equivalents' provisions of SOLAS *Chapter 1 - General provisions*, Regulation 5, see *Ch 1, 1.4 Equivalents* of the Rules for Ships for Liquid Chemicals and/or the the Rules for Ships for Liquefied Gases, as appropriate, see also *Pt 6, Ch 2, 14.1 General 14.1.2*.

Earthed intrinsically safe circuits are permitted to pass into and through hazardous spaces and zones.

5.1.3 System voltages for both alternating current and direct current in general are not to exceed:

- 15 000 V for generation and power distribution;
- 500 V for cooking and heating equipment permanently connected to fixed wiring;
- 250 V for lighting, heaters in cabins and public rooms, and other applications not mentioned above.

Voltages above these will be the subject of special consideration.

5.1.4 The arrangement of the main system of supply is to be such that a fire or other casualty in any space containing the main source of electrical power, associated converting equipment, if any, the main switchboard and the main lighting switchboard will not render inoperable any emergency service, other than those located within the space where the fire or casualty has occurred.

5.1.5 The main switchboard is to be so placed relative to the main source of power that, as far as is practicable, the integrity of the main system of supply will be affected only by a fire or other casualty in one space.

5.1.6 The arrangement of the emergency system of supply is to be such that a fire or other casualty in spaces containing the emergency source of electrical power, associated converting equipment, if any, the emergency switchboard and the emergency lighting switchboard, will not cause loss of services required to maintain the propulsion and safety of the ship.

5.1.7 Distribution systems required in an emergency are to be so arranged that a fire in any one main fire zone, as defined by SOLAS 1974 as amended *Regulation 3 - Definitions*, will not interfere with the emergency distribution in any other such zone.

5.2 Essential services

5.2.1 Essential services that are required by *Pt 5 Main and Auxiliary Machinery* to be duplicated are to be served by individual circuits, separated in their switchboard or section board and throughout their length as widely as is practicable without the use of common feeders, protective devices, control circuits or controlgear assemblies, so that any single fault will not cause the loss of both services.

5.2.2 Where *Pt 6, Ch 2, 5.2 Essential services 5.2.1* is applicable the main busbars of the switchboard, or section boards, are to be capable of being split, by a multipole linked circuit breaker, disconnecter or switch-disconnector, into at least two independent sections, each supplied by at least one generator, either directly or through a converter. The essential services are to be equally divided, as far as is practicable, between the independent sections.

5.2.3 Where *Pt 6, Ch 2, 5.2 Essential services 5.2.2* is applicable provision is to be made to transfer to a temporary circuit those essential services which are not required to be, and have not been, duplicated in the event of loss of their normal section of switchboard or section-board.

5.3 Isolation and switching

5.3.1 The incoming and outgoing circuits from every switchboard or section board are to be provided with a means of isolation and switching to permit each circuit to be switched off:

- (a) on load;
- (b) for mechanical maintenance;
- (c) in an emergency to prevent or remove danger.

In addition the requirements of *Pt 6, Ch 2, 5.3 Isolation and switching 5.3.2* and *Pt 6, Ch 2, 5.3 Isolation and switching 5.3.3* are to be complied with.

5.3.2 Isolation and switching is to be by means of a circuit-breaker or switch arranged to open and close simultaneously all insulated poles. Where a switch is used as the means of isolation and switching, it is to be capable of:

- (a) switching off the circuit on load;
- (b) withstanding, without damage, the overcurrents which may arise during overloads and short-circuit.

In addition, these requirements do not preclude the provision of single pole control switches in final sub-circuits, for example light switches. For circuit-breakers, see *Pt 6, Ch 2, 6.5 Circuit-breakers* and *Pt 6, Ch 2, 7.3 Circuit-breakers*.

5.3.3 Provision is to be made, in accordance with one of the following, to prevent any circuit being inadvertently energised:

- (a) the circuit-breaker or switch can be withdrawn, or locked in the open position;
- (b) the operating handle of the circuit-breaker or switch can be removed;
- (c) the circuit fuses, where fitted, can be readily removed and retained by authorised personnel.

5.3.4 Where arrangements are in place for automatic changeover between two or more supplies of electrical power in the event of failure of one supply, the arrangements are to be such that a fault in one feeder does not result in the loss of all supplies to the automatic changeover switch.

5.3.5 Where a section board, distribution board or item of equipment can be supplied by more than one circuit, a switching device is to be provided to permit each incoming circuit to be isolated and the supply transferred to the alternative circuit. In addition, the requirements of *Pt 6, Ch 2, 5.3 Isolation and switching 5.3.6* and *Pt 6, Ch 2, 5.3 Isolation and switching 5.3.7* are to be complied with.

5.3.6 The switching device required by *Pt 6, Ch 2, 5.3 Isolation and switching 5.3.5* is to be situated within or adjacent to the section board, distribution board or item of equipment. Where necessary, interlocking arrangements are to be provided to prevent circuits being inadvertently energised.

5.3.7 A notice is to be fixed to any section board, distribution board or item of equipment to which *Pt 6, Ch 2, 5.3 Isolation and switching 5.3.5* applies warning personnel before gaining access to live parts of the need to open the appropriate circuit-breakers or switches, unless an interlocking arrangement is provided so that all circuits concerned are isolated before access is gained.

5.3.8 Tankers designed in accordance with IEC 60092-502: *Electrical installations in ships – Part 502: Tankers – Special features*, see *Pt 6, Ch 2, 14.1 General 14.1.2*, are to meet the requirements of *Pt 6, Ch 2, 5.3 Isolation and switching* of that Standard.

5.3.9 Where high voltage equipment is contained in a room or protected area which also forms its enclosure, the access door(s) of the space is to be so interlocked that it cannot be opened until:

- the high voltage supply(ies) to the equipment is switched off;
- the equipment and its cable(s) are earthed down to dissipate stored energy sufficient to ensure personnel safety.

5.3.10 The access to the space(s) described in *Pt 6, Ch 2, 5.3 Isolation and switching 5.3.9* are to be suitably marked to indicate the danger of high voltage.

5.4 Insulated distribution systems

5.4.1 A device(s) is to be installed for every insulated distribution system, whether primary or secondary, for power, heating and lighting circuits, to continuously monitor the insulation level to earth and to operate an alarm in the engine control room, or equivalent attended position, in the event of an abnormally low level of insulation resistance, *see also Pt 6, Ch 1, 4.2 Alarm system for machinery.*

5.4.2 Where any insulated lower voltage system is supplied through transformers from a high voltage system, adequate precautions are to be taken to prevent the low voltage system being charged by capacitive leakage from the high voltage system.

5.4.3 Tankers designed in accordance with IEC 60092-502: *Electrical installations in ships – Part 502: Tankers – Special features* (see Pt 6, Ch 2, 14.1 General 14.1.2) are to meet the requirements of Pt 6, Ch 2, 5.3 Isolation and switching of that Standard.

5.4.4 Where filters are fitted, for example to reduce EMC susceptibility, these are not to cause distribution systems to be unintentionally connected to earth.

5.5 Earthed distribution systems

5.5.1 No fuse, non-linked switch or non-linked circuit-breaker is to be inserted in an earthed conductor. Any switch or circuit-breaker fitted is to operate simultaneously in the earthed conductor and the insulated conductors. These requirements do not preclude the provision (for test purposes) of an isolating link to be used only when the other conductors are isolated.

5.5.2 For high voltage systems, where the earthed neutral system of generation and primary distribution is used, earthing is to be through an impedance in order to limit the total earth fault current to a magnitude which does not exceed that of the three phase short-circuit current for which the generators are designed.

5.5.3 Generator neutrals may be connected in common, provided that the third harmonic content of the voltage waveform of each generator does not exceed five per cent.

5.5.4 Where a switchboard is split into sections operated independently or where there are separate switchboards, neutral earthing is to be provided for each section or for each switchboard. Means are to be provided to ensure that the earth connection is not removed when generators are isolated.

5.5.5 A means of isolation is to be fitted in the earthing connection of each generator so that generators can be completely isolated for maintenance.

5.5.6 All earthing impedances are to be connected to the hull. The connections to the hull are to be so arranged that any circulating currents in the earth connections do not interfere with radio, radar, communication and control equipment circuits.

5.5.7 Tankers designed in accordance with IEC 60092-502: *Electrical installations in ships – Part 502: Tankers – Special features* (see Pt 6, Ch 2, 14.1 General 14.1.2) are to meet the requirements of Pt 6, Ch 2, 5.3 Isolation and switching of that Standard.

5.6 Diversity factor

5.6.1 Circuits supplying two or more final sub-circuits are to be rated in accordance with the total connected load subject, where justified, to the application of a diversity factor. Where spare ways are provided on a section or distribution board, an allowance for future increase of load is to be added to the total connected load before application of any diversity factor.

5.6.2 A diversity factor may be applied to the calculation for size of cable and rating of switchgear and fusegear, taking into account the duty cycle of the connected loads and the frequency and duration of any motor starting loads.

5.6.3 For winches and crane motors the diversity factor is to be calculated and submitted when required.

5.7 Lighting circuits

5.7.1 Lighting circuits are to be supplied by final sub-circuits separate from those for heating and power. This does not preclude the supply from a lighting circuit supplying a single fixed appliance, such as a cabin fan, a dry shaver, a wardrobe or anti-condensation heater, taking a maximum current of 2 A.

5.7.2 Lighting for the following spaces is to be supplied from at least two final sub-circuits in such a way that failure of one of the circuits does not leave the space in darkness. One of these circuits may be an emergency circuit provided it is normally energised.

- Spaces that are required to be lit for the safe working of the ship, such as control stations, normal working spaces, etc.

- Spaces where there may be a hazard due to movement of crew, passengers and/or equipment, such as in corridors, working passage ways, stairways leading to boat decks, public rooms, etc.
- Spaces where there may be a hazard due to moving machinery and hot parts, such as in machinery spaces, workshops, large galleys, laundries, etc.

5.7.3 Lighting for enclosed hazardous spaces is to be supplied from at least two final sub-circuits to permit light from one circuit to be retained while maintenance is carried out on the other. One of these circuits may be an emergency circuit, provided it is normally energised in which case the arrangements are to comply with *Pt 6, Ch 2, 3 Emergency source of electrical power*.

5.7.4 Emergency lighting is to be fitted in accordance with *Pt 6, Ch 2, 3 Emergency source of electrical power*, see also *Pt 6, Ch 2, 18 Crew and passenger emergency safety systems*.

5.7.5 Lighting of unattended spaces, such as cargo spaces, is to be controlled by multipole linked switches situated outside such spaces. Provision is to be made for the complete isolation of these circuits, and locking the means of control in the off position.

5.7.6 Where lighting circuits in the cargo pump-rooms of tankers are also used for emergency lighting, and have been interlocked with the ventilation, the interlocking arrangements are:

- not to cause the lighting to go out following a failure of the ventilation system; and
- not to prevent operation of the emergency lighting following the loss of the main source of electrical power.

5.8 Motor circuits

5.8.1 A separate final sub-circuit is to be provided for every motor for essential services, see *Pt 6, Ch 2, 1.6 Definitions 1.6.1*.

5.9 Motor control

5.9.1 Every electric motor is to be provided with efficient means for starting and stopping so placed as to be easily operated by the person controlling the motor. Every motor above 0,5 kW is to be provided with control apparatus as given in *Pt 6, Ch 2, 5.9 Motor control 5.9.2*.

5.9.2 Means to prevent undesired restarting after a stoppage due to low volts or complete loss of volts are to be provided. This does not apply to motors where a dangerous condition might result from the failure to restart automatically, e.g. steering gear motor.

5.9.3 Means for automatic disconnection of the supply in the event of excess current due to mechanical overloading of the motor are to be provided, see also *Pt 6, Ch 2, 6.11 Motor circuits*.

5.9.4 Motor controlgear is to be suitable for the starting current and for the full load rated current of the motor.

■ *Section 6* **System design – Protection**

6.1 General

6.1.1 Installations are to be protected against overcurrents including short-circuits, and other electrical faults. The tripping/fault clearance times of the protective devices are to provide complete and co-ordinated protection to ensure:

- availability of essential and emergency services under fault conditions through discriminative action of the protective devices; as far as practicable the arrangements are also to secure the availability of other services;
- elimination of the fault to reduce damage to the system and hazard of fire.

6.1.2 Short-circuit and overload protection are to be provided in each non-earthed line of each system of supply and distribution, unless exempted under the provisions of any paragraph in this Section.

6.1.3 The protection of circuits is to be such that a fault in a circuit does not cause the interruption of supplies used to provide emergency or essential services other than those dependent on the circuit where the fault occurred. For circuits used to provide essential services which need not necessarily be in continuous operation to maintain propulsion and steering but which are necessary for maintaining the vessel's safety, arrangements that ensure that a fault in a circuit does not cause the sustained

interruption of supply to healthy circuits may be accepted. Such arrangements are to ensure the supply to healthy circuits is automatically re-established in sufficient time after a fault in a circuit.

6.1.4 Protection systems are to be developed using a systematic design procedure incorporating verification and validation methods to ensure successful implementation of the requirements above. Details of the procedures used are to be submitted when requested. An approved copy of the details required by *Pt 6, Ch 2, 1.2 Documentation required for design review 1.2.5* and *Pt 6, Ch 2, 1.2 Documentation required for design review 1.2.6* is to be retained on board and made available to the Surveyor on request. Access to protection relays setpoints is to be restricted, such that they will generally only be adjusted by authorised personnel to avoid accidental operation. A record is to be kept of the initial setpoints and any subsequent changes made to them. These details are to be made available to the Surveyor on request.

6.1.5 Short-circuit protection is to be provided for each source of power and at each point at which a distribution circuit branches into two or more subsidiary circuits.

6.1.6 Where protection for generator power circuits is provided at the associated switchboard, the cabling between generator and switchboard is to be of a type, and installed in a manner such as to minimise the risk of short-circuit.

6.1.7 Protection for battery circuits is to be provided at a position external and adjacent to the battery compartments. Where arrangements comply with *Pt 6, Ch 2, 12.3 Location 12.3.5*, the protection may be installed at a suitable location in the battery compartment.

6.1.8 Protection may be omitted from the following:

- (a) Engine starting battery circuits.
- (b) Circuits for which it can be shown that the risk resulting from spurious operation of the protective device may be greater than that resulting from a fault.

6.1.9 Short-circuit protection may be omitted from cabling or wiring to items of equipment internally protected against short-circuit or where it can be shown that they are unlikely to fail to a short-circuit condition and where the cabling or wiring is installed in a manner such as to minimise the risk of short-circuit.

6.1.10 Overload protection may be omitted from the following:

- (a) one line circuits of the insulated type;
- (b) circuits supplying equipment incapable of being overloaded, or overloading the associated supply cable, under normal conditions, and unlikely to fail to an overload condition.

6.2 Protection against short-circuit

6.2.1 Protection against short-circuit currents is to be provided by circuit-breakers or fuses.

6.2.2 The rated short-circuit making and breaking capacity of every protective device is to be adequate for the prospective fault level at its point of installation; the requirements for circuit-breakers and fuses are detailed in *Pt 6, Ch 2, 6.5 Circuit-breakers* and *Pt 6, Ch 2, 6.6 Fuses* respectively.

6.2.3 The prospective fault current is to be calculated for the following set of conditions:

- (a) all generators, motors and, where applicable, all transformers, connected as far as permitted by any interlocking arrangements;
- (b) a fault of negligible impedance close up to the load side of the protective device.

6.2.4 In the absence of precise data, the prospective fault current may be taken to be:

- (a) for alternating current systems at the main switchboard: 10 x f.l.c. (rated full load current) for each generator that may be connected, or, if the subtransient direct axis reactance, X''_d , of each generator is known,

$$\frac{\text{f.l.c.}}{X''_d(\text{p.u.})}$$

for each generator, and 3 x f.l.c. for motors simultaneously in service.

The value derived from the above is an approximation to the r.m.s. symmetrical fault current; the peak asymmetrical fault current may be estimated to be 2,5 times this figure (corresponding to a fault power factor of approximately 0,1).

- (b) battery-fed direct current systems at the battery terminals:
 - (i) 15 times ampere hour rating of the battery for vented lead-acid cells, or of alkaline type intended for discharge at low rates corresponding to a battery duration exceeding three hours, or

- (ii) 30 times ampere hour rating of the battery for sealed lead-acid cells having a capacity of 100 Ampere hours or more, or of alkaline type intended for discharge at high rates corresponding to a battery duration not exceeding three hours and,
- (iii) 6 x f.l.c. for motors simultaneously in service (if applicable).

6.3 Protection against overload

6.3.1 The characteristics of protective devices provided for overload protection are to ensure that cabling and electrical machinery are protected against overheating resulting from mechanical or electrical overload.

6.3.2 Fuses of a type intended for short-circuit protection only (e.g. high-voltage fuses or fuses complying with IEC 60269-1: *Low-voltage fuses – Part 1: General requirements*, of type 'a') are not to be used for overload protection.

6.4 Protection against earth faults

6.4.1 Every distribution system that has an intentional connection to earth, by way of an impedance, is to be provided with a means to continuously monitor and indicate the current flowing in the earth connection.

6.4.2 If the current in the earth connection exceeds 5 A there is to be an alarm and the fault current is to be automatically interrupted or limited to a safe value.

6.4.3 The rated short-circuit capacity of any device used for interrupting earth fault currents is to be not less than the prospective earth fault current at its point of installation.

6.4.4 Insulated neutral systems with harmonic distortion of the voltage waveform, which may result in earth fault currents exceeding the level given in *Pt 6, Ch 2, 6.4 Protection against earth faults 6.4.2* because of capacitive effects, are to be provided with arrangements to isolate the faulty circuit(s).

6.5 Circuit-breakers

6.5.1 Circuit-breakers for alternating current systems are to satisfy the following conditions:

- (a) the r.m.s. symmetrical breaking current for which the device is rated is to be not less than the r.m.s. value of the a.c. component of the prospective fault current, at the instant of contact separation (i.e. first half cycle, or time of interruption where an intentional time delay is provided to ensure suitability);
- (b) the peak asymmetrical making current for which the device is rated is not to be less than the peak value of the prospective fault current at the first half cycle, allowing for maximum asymmetry;
- (c) the power factor at which the device short-circuit ratings are assigned is to be no greater than that of the prospective fault current; alternatively for high voltage, the rated percentage d.c. component of the short-circuit breaking current of the device is to be not less than that of the prospective fault current.

6.5.2 Circuit-breakers for d.c. systems are to have a breaking current not less than the initial prospective fault current. The time constant of the fault current is not to be greater than that for which the circuit-breaker was tested.

6.5.3 The fault ratings considered in *Pt 6, Ch 2, 6.5 Circuit-breakers 6.5.1* and *Pt 6, Ch 2, 6.5 Circuit-breakers 6.5.2*, are to be assigned on the basis that the device is suitable for further use after fault clearance.

6.5.4 Circuit-breaker selection is, and ratings are, to be in accordance with the relevant requirements of IEC 60092- 202: *Electrical installations in ships – Part 202: System design – Protection*. Alternative methods acceptable to LR of selecting suitable circuit-breakers may be considered.

6.6 Fuses

6.6.1 Fuses for a.c. systems are to have a breaking current rating not less than the initial r.m.s. value of the a.c. component of the prospective fault current.

6.6.2 Fuses for d.c. systems are to have a d.c. breaking current rating not less than the initial value of the prospective fault current.

6.7 Circuit-breakers requiring back-up by fuse or other device

6.7.1 The use of a circuit-breaker having a short-circuit current capacity less than the prospective short-circuit current at the point of installation is permitted, provided that it is preceded by a device having at least the necessary short-circuit capacity. The generator circuit-breakers are not to be used for this purpose.

6.7.2 The same device may back-up more than one circuit-breaker provided that no essential or emergency service is supplied from there, or that any such service is duplicated by arrangements unaffected by tripping of the device.

6.7.3 The combination of back-up device and circuit-breaker is to have a short-circuit performance at least equal to that of a single circuit-breaker satisfying the requirements of *Pt 6, Ch 2, 6.5 Circuit-breakers*.

6.7.4 Evidence of testing of the combination is to be submitted for consideration; alternatively, consideration may be given to arrangements where it can be shown that:

- (a) the takeover current, above which the back-up device would clear a fault, is not greater than the rated short-circuit breaking capacity of the circuit-breaker and;
- (b) the characteristics of the back-up device, and the prospective fault level, are such that the peak fault current rating of the circuit-breaker cannot be exceeded and;
- (c) the Joule integral of the let-through current of the back-up device does not exceed that corresponding to the rated breaking current and opening time of the circuit-breaker.

6.8 Protection of generators

6.8.1 The protective gear required by *Pt 6, Ch 2, 6.8 Protection of generators 6.8.2* and *Pt 6, Ch 2, 6.8 Protection of generators 6.8.3* is to be provided as a minimum.

6.8.2 Generators not arranged to run in parallel are to be provided with a circuit-breaker arranged to open simultaneously, in the event of short-circuit, overload or under-voltage, all insulated poles. In the case of generators rated at less than 50 kW, a multipole linked switch with a fuse, complying with *Pt 6, Ch 2, 5.3 Isolation and switching 5.3.2*, in each insulated pole will be acceptable.

6.8.3 Generators arranged to operate in parallel are to be provided with a circuit-breaker arranged to open simultaneously, in the event of a short-circuit, an overload or an under-voltage, all insulated poles. This circuit-breaker is to be provided with reverse power protection with time delay, selected or set within the limits of 2 per cent to 15 per cent of full load to a value fixed in accordance with the characteristics of the prime mover; a fall of 50 per cent in the applied voltage is not to render the reverse power mechanism inoperative, although it may alter the amount of reverse power required to open the breakers.

6.8.4 The generator circuit-breaker short-circuit and overload tripping arrangements, or fuse characteristics, are to be such that the machine's thermal withstand capability is not exceeded.

6.8.5 All high-voltage generators and low-voltage generators having a capacity of 1500 kVA or above are to be equipped with a protective device which, in the event of a short-circuit in the generator or in the cables between the generator and its circuit-breaker, will instantaneously open the circuit-breaker and de-excite the generator.

6.8.6 The voltage and time delay settings of the under-voltage release mechanism(s) required by *Pt 6, Ch 2, 6.8 Protection of generators 6.8.2* and *Pt 6, Ch 2, 6.8 Protection of generators 6.8.3* are to be chosen to ensure that the discriminative action required by *Pt 6, Ch 2, 6.1 General 6.1.1* is maintained.

6.9 Load management

6.9.1 Arrangements are to be made to disconnect automatically, after an appropriate time delay, circuits of the following categories, when the generator(s) is/are overloaded, sufficient to ensure the connected generating set(s) is/are not overloaded:

- (a) non-essential circuits;
- (b) circuits feeding services for habitability, see *Pt 6, Ch 2, 1.6 Definitions 1.6.2*;
- (c) in cargo ships, circuits for cargo refrigeration.

Note For emergency generators see *Pt 6, Ch 2, 3.3 Emergency source of electrical power in passenger ships 3.3.1* and *Pt 6, Ch 2, 3.4 Emergency source of electrical power in cargo ships 3.4.1* as applicable.

6.9.2 If required, this load switching may be carried out in one or more stages, in which case the non-essential circuits are to be included in the first group to be disconnected.

6.9.3 The load management of power systems supplying electric propulsion motors is to satisfy the requirements of *Pt 6, Ch 2, 16.3 Power requirements*.

6.9.4 Consideration is to be given to providing means to inhibit automatically the starting of large motors, or the connection of other large loads, until sufficient generating capacity is available to supply them.

6.10 Feeder circuits

6.10.1 Isolation and protection of each feeder circuit is to be ensured by a multipole circuit-breaker or linked switch with a fuse in each insulated conductor. Protection is to be in accordance with *Pt 6, Ch 2, 6.2 Protection against short-circuit* and *Pt 6, Ch 2, 6.3 Protection against overload*. The protective devices are to allow excess current to pass during the normal accelerating period of motors.

6.11 Motor circuits

6.11.1 Motors of rating exceeding 0,5 kW and all motors for essential services are to be protected individually against overload and short-circuit. For motors which for essential services are duplicated, the overload protection may be replaced by an overload alarm; arrangements for steering gear motors are to comply with *Pt 6, Ch 2, 14.1 General*.

6.11.2 Protection for both the motor and its supply cable may be provided by the same device, provided that due account is taken of any differences between ratings of cable and motor.

6.11.3 Where operation of an item of equipment is dependent upon a number of motors, consideration may be given to the provision of a common means of short-circuit protection.

6.11.4 For motors for intermittent service, the characteristics of the arrangements for overload protection are to be chosen in relation to the load factor(s) of the motor(s).

6.11.5 Where fuses are used to protect polyphase motor circuits, means are to be provided to protect the motor from unacceptable overcurrent in the case of single phasing.

6.12 Protection of transformers

6.12.1 Short-circuit protection for transformers is to be provided by circuit-breakers or fuses in the primary circuit and in addition, overload protection is to be provided either in the primary or secondary circuit.

6.12.2 Arrangements are to be made to prevent the primary windings of transformers being inadvertently energised from their secondary side when disconnected from their source supply.

6.13 Harmonic filters

6.13.1 Harmonic filters' final sub-circuits are to be protected individually against overload and short-circuit.

6.13.2 An alarm is to be initiated in the event of protective device operation.

6.13.3 Where parallel harmonic filters are used, an alarm is to be initiated in the event of current imbalance that could lead to failure of a harmonic filter.

■ *Section 7*
Switchgear and controlgear assemblies

7.1 General requirements

7.1.1 Switchgear and controlgear assemblies and their components are to comply with the following standards, as appropriate for the nominal voltage and, amended where necessary for ambient temperature and other environmental conditions:

- (a) IEC 61439: *Low-voltage switchgear and controlgear assemblies* (relevant parts);
- (b) IEC 62271-200: *High-voltage switchgear and controlgear – Part 200: AC metal-enclosed switchgear and controlgear for rated voltages above 1 kV and up to and including 52 kV*;
- (c) IEC 62271-201: *High-voltage switchgear and controlgear – Part 201: AC insulation-enclosed switchgear and controlgear for rated voltages above 1 kV and up to and including 52 kV*;
- (d) IEC 60092-503: *Electrical installations in ships – Part 503: Special features – AC supply systems with voltages in the range of above 1 kV up to and including 15 kV*;
- (e) IEC 60255: *Measuring relays and protection equipment*; or
- (f) an acceptable and relevant National Standard.

In addition, the requirements of *Pt 6, Ch 2, 7.2 Busbars* to *Pt 6, Ch 2, 7.19 Disconnectors and switch-disconnectors* are to be complied with.

7.2 Busbars

7.2.1 Busbars and their connections are to be of copper or aluminium, all connections being so made as to inhibit corrosion/oxidisation between current-carrying mating faces, which may result in poor electrical contact giving rise to overheating. Busbars and their supports are to be designed to withstand the mechanical stresses which may arise during short-circuits. A test report or calculation to verify the short-circuit withstand strength of the busbar system is to be submitted for consideration when required.

7.2.2 For bare conductors, where no precautions are taken against surface oxidisation, the temperature rise limit at rated normal current is not to exceed 45°C. Where suitable precautions are taken against surface oxidisation, e.g. by using silver, nickel or tin coated terminations, a temperature rise limit not exceeding 60°C is permitted. Where the busbar temperature rises are above 45°C it is to be ensured that there is no adverse effect on equipment adjacent to and/or connected to the busbars and that the temperature rise limits of any materials in contact with the busbars are not exceeded. A test report or calculation to verify the rated current assigned to the busbar system is to be submitted for consideration when required.

7.3 Circuit-breakers

7.3.1 Circuit-breakers are to comply with one of the following standards amended where necessary for ambient temperature:

- (a) IEC 60947-2: *Low-voltage switchgear and controlgear – Part 2: Circuit-breakers*; or
- (b) IEC 62271-100: *High-voltage switchgear and controlgear – Part 100: Alternating current circuit-breakers*; or
- (c) an acceptable and relevant National Standard.

Type test reports to verify the characteristics of a circuit-breaker are to be submitted for consideration when required.

7.3.2 Circuit-breakers are to be capable of isolation.

7.3.3 Circuit-breakers are to be of the trip free type and, where applicable, be fitted with anti-pumping control.

7.3.4 High-voltage circuit-breakers are to be of the withdrawable type or with equivalent means or arrangements permitting safe maintenance whilst the busbars are live.

7.3.5 Where the means of setting adjustable protection characteristics are not durably marked and locked in position and cannot be visually inspected (e.g. electronic storage), the settings of characteristics are to be recorded and a copy of the records included in the details retained on board, see *Pt 6, Ch 2, 6.1 General 6.1.4*.

7.3.6 Air circuit-breakers for essential or emergency services and rated at 800 A and above are to have a cumulative count kept of the switching operations of the electrical contacts. This count, along with the manufacturer's details for the circuit-breaker, including the maximum number of switching operations for the electrical contacts, is to be retained on board. These details are to be made available to the Surveyor on request.

7.4 Contactors

7.4.1 High-voltage contactors are to comply with one of the following standards amended where necessary for ambient temperature:

- (a) IEC 62271-106: *High-voltage switchgear and controlgear – Part 106: Alternating current contactors, contactor-based controllers and motor-starters*; or
- (b) an acceptable and relevant National Standard.

Type test reports to verify the characteristics of a contactor are to be submitted for consideration when required.

7.4.2 High-voltage contactors are to be of the withdrawable type or with equivalent means or arrangements permitting safe maintenance whilst the busbars are live.

7.5 Creepage and clearance distances

7.5.1 The shortest distances between conductive parts and between conductive parts and earth, in air or along the surface of an insulating material, are to be suitable for the rated voltage having regard to:

- the nature of the insulating material;
- the transient over voltages developed by switching and fault conditions; and
- the environment into which the assembly will be installed.

Each assembly type is to be subjected to an impulse voltage test in accordance with its constructional Standard or, alternatively, the minimum distances for bare conductive parts in switchgear and controlgear assemblies given in *Table 2.7.1 Minimum clearance distances* are to be used.

Table 2.7.1 Minimum clearance distances

Nominal voltage (V)	Minimum clearance distance (mm)		
	Verified assemblies, see Note 2		Non-verified assemblies
	Main switchboards	Other switchgear and controlgear	Main switchboards and other switch and controlgear
≤ 250 (see Note 1)	8	8	15
≤ 690 (see Note 1)	8	8	20
≤ 1000 (see Note 1)	8	8	25
< 3,300	32	26	55
< 6600	60	50	90
< 11,000	100	80	120
≤ 15,000	See Note 3	See Note 3	160

Note 1 For assemblies installed in spaces where the pollution degree is > 3, see Pt 6, Ch 2, 7.5 Creepage and clearance distances 7.5.2.

Note 2 For the verification requirements for a verified assembly refer to IEC 61439-2.

Note 3 Clearance distances with reference to the applicable relevant National or International Standards, are to be submitted for approval, see Pt 6, Ch 2, 1.3 Documentation required for supporting evidence 1.3.4.

7.5.2 For assemblies with a rated voltage of up to and including 1kV, the requirement of Pt 6, Ch 2, 7.5 Creepage and clearance distances 7.5.1 may be met by complying with IEC 60092-302 *Electrical installations in ships – Part 302: Low-voltage switchgear and controlgear assemblies*.

- *Table 2.7.1 Minimum clearance distances* and *Table 2.7.2 Minimum creepage distances* indicate the minimum clearance and creepage distances normally allowed.
- For assemblies installed in spaces where the environmental conditions are in excess of pollution degree 3 (that is conductive pollution occurs or dry, non conductive pollution occurs which is expected to be conductive due to condensation) as defined in IEC 61439-1, *Low-voltage switchgear and controlgear assemblies – Part 1: General requirements*; the clearance distances for non-verified assemblies are to be used.
- A minimum creepage distance of 16 mm is permitted for assemblies verified in accordance with the requirements of IEC 61439-2, *Low-voltage switchgear and controlgear assemblies – Part 2: Power switchgear and controlgear assemblies*.
- An alternative relevant National or International Standard may be used when an acceptable justification is submitted as part of the documentation required by Pt 6, Ch 2, 1.3 Documentation required for supporting evidence 1.3.4.

7.5.3 For assemblies with a rated voltage above 1kV, the requirement of Pt 6, Ch 2, 7.5 Creepage and clearance distances 7.5.1 may be met by complying with IEC 60092-503 *Electrical installations in ships – Part 503: Special features – AC supply systems with voltages in the range of above 1 kV up to and including 15 kV*.

- *Table 2.7.1 Minimum clearance distances* and *Table 2.7.2 Minimum creepage distances* indicate the minimum clearance and creepage distances normally allowed.
- For main switchboards rated at above 1kV, a minimum clearance distance of 25 mm is required for busbars and other bare conductors.

An alternative relevant National or International Standard may be used when an acceptable justification is submitted as part of the documentation required by *Pt 6, Ch 2, 1.3 Documentation required for supporting evidence 1.3.4.*

Table 2.7.2 Minimum creepage distances

Nominal voltage (V)	Minimum creepage distance (mm)	
	Main switchboards	Other switchgear and controlgear
≤ 250 (see Note 1)	20	20
≤ 690 (see Note 1)	25	25
≤ 1000 (see Note 1)	35	35
< 3,300	48	See Note 2
< 6,600	90	70
< 11,000	150	120
≤ 15,000	See Note 2	See Note 2

Note 1 For verified assemblies a minimum creepage distance of 16 mm is permitted for LV switchboards, see *Pt 6, Ch 2, 7.5 Creepage and clearance distances 7.5.2.*

Note 2 Creepage distances, with reference to the applicable relevant National or International Standards, are to be submitted for approval, see *Pt 6, Ch 2, 1.3 Documentation required for supporting evidence 1.3.3.*

7.5.4 Suitable shrouding or barriers are to be provided in way of connections to equipment, where necessary, to maintain the minimum distances in *Table 2.7.1 Minimum clearance distances.*

7.6 Degree of protection

7.6.1 Low voltage assemblies where the rated voltage between conductors or to earth exceeds 55 V a.c. or 250 V d.c. are to be of the deadfront or enclosed type. High-voltage assemblies are to be of the enclosed type.

7.6.2 Where switchboards or section boards are required to comply with *Pt 6, Ch 2, 5.2 Essential services 5.2.2*, barriers are to be installed to provide protection for the independent sections against contamination due to the products of arcing, which may result in a fault.

7.6.3 Segregation between low-voltage and high-voltage circuits and equipment installed within common assemblies is to be in accordance with IEC 62271-1: *High-voltage switchgear and controlgear – Part 1: Common specifications.*

7.7 Distribution boards

7.7.1 Distribution boards are to be suitably enclosed unless they are installed in a cupboard or compartment to which only authorised persons have access in which case the cupboard may serve as an enclosure, see *Pt 6, Ch 2, 7.16 Position of switchboards 7.16.4.*

7.8 Earthing of high-voltage switchboards

7.8.1 High-voltage switchboards are to be provided with suitable means to earth isolated circuits so that they are discharged and so maintained that they are safe to touch.

7.8.2 Protective shutters associated with withdrawable parts are to be clearly marked to indicate the incoming and outgoing circuits and bus tie connections. The colour coding shall be as follows:

- Incoming (busbar side) – red;
- Outgoing (circuit side) – yellow; and
- Bus ties – red

7.9 Fuses

7.9.1 Fuses are to comply with one of the following Standards amended where necessary for ambient temperature:

- (a) IEC 60269 (all parts): *Low-voltage fuses* ;
- (b) IEC 60282-1: *High-voltage fuses – Part 1: Current-limiting fuses*;
- (c) acceptable and relevant National Standard for enclosed current-limiting fuses.

Type test reports to verify the characteristics of a fuse are to be submitted for consideration when required.

7.10 Handrails or handles

7.10.1 All main and emergency switchboards are to be provided with an insulated handrail or insulated handles suitably fitted on the front of the switchboard. Where access to the rear is required, a horizontal insulated handrail is to be suitably fitted on the rear of the switchboard.

7.11 Instruments for alternating current generators

7.11.1 For alternating current generators not operated in parallel, each generator is to be provided with at least one voltmeter, one frequency meter, and one ammeter with an ammeter switch to enable the current in each phase to be read, or an ammeter in each phase. Generators above 50 kVA are also to be provided with a wattmeter.

7.11.2 For alternating current generators operated in parallel, each generator is to be provided with a wattmeter, and one ammeter with an ammeter switch to enable the current in each phase to be read, or an ammeter in each phase.

7.11.3 For paralleling purposes, two voltmeters, two frequency meters and two synchronising devices, of which one at least is to be a synchroscope or a set of lamps are to be provided. One voltmeter and one frequency meter are to be connected to the busbars, the other voltmeter and frequency meter are to be switched to enable the voltage and frequency of any generator to be measured. Where the electrical power requirement to maintain the ship in a normal operational and habitable condition is usually supplied by two or more generators operating in parallel, the two synchronising devices are to be independent of each other, see also Pt 6, Ch 2, 2.2 Number and rating of generators and converting equipment 2.2.1.

7.11.4 The indicators and displays required by Pt 6, Ch 2, 7.11 Instruments for alternating current generators 7.11.1 to Pt 6, Ch 2, 7.11 Instruments for alternating current generators 7.11.3 are to be located and arranged such that they may be viewed at a single operating position. Where manual paralleling is provided, it is to be possible to adjust voltage and frequency at this position; generators are to have controls to adjust their voltage and frequency located at the single operating position. Access to voltage adjustment is to be restricted, such that it will generally only be used by authorised personnel to avoid accidental operation.

7.11.5 Where the indications of voltage, frequency, current and power are displayed digitally, the indications are to be separately displayed.

7.12 Instrument scales

7.12.1 The upper limit of the scale of every voltmeter is to be approximately 120 per cent of the nominal voltage of the circuit, and the nominal voltage is to be clearly indicated.

7.12.2 The upper limit of the scale of every ammeter is to be approximately 130 per cent of the normal rating of the circuit in which it is installed. Normal full load is to be clearly indicated.

7.12.3 Kilowatt meters for use with alternating current generators which may be operated in parallel are to be capable of indicating 15 per cent reverse power.

7.12.4 Where the indications provided by the instrumentation required by Pt 6, Ch 2, 7.11 Instruments for alternating current generators are displayed digitally, nominal voltage, over voltage, over current and reverse power indications are to be indicated by an appropriate means. The information provided is to be clearly visible and immediately available.

7.12.5 In general, indications provided by instrumentation which are displayed digitally are not to change more frequently than twice per second.

7.13 Labels

7.13.1 The identification of individual circuits and their devices is to be made on labels of durable material. The ratings of fuses and settings of protective devices are also to be indicated. Section and distribution boards are to be marked with the rated voltage.

7.14 Protection

7.14.1 See *Pt 6, Ch 2, 6 System design – Protection*.

7.15 Wiring

7.15.1 Insulated wiring connecting components are to be stranded, flame retardant and manufactured in accordance with a relevant and acceptable National Standard.

7.16 Position of switchboards

7.16.1 An unobstructed space not less than 1 m wide is to be provided in front of switchboards and section boards. When switchboards and section boards contain withdrawable equipment the unobstructed space is to be not less than 0,4 m wide with this equipment in its fully withdrawn position.

7.16.2 Where necessary, the space at the rear of switchboards and section boards is to be ample to permit maintenance and in general not less than 0,6 m except that this may be reduced to 0,5 m in way of stiffeners or frames.

7.16.3 The spaces defined in *Pt 6, Ch 2, 7.16 Position of switchboards 7.16.1* and *Pt 6, Ch 2, 7.16 Position of switchboards 7.16.2* are to have non-slip surfaces. Where access to live parts within switchboards and section boards is normally possible the surface is, in addition, to be electrically insulated.

7.16.4 So far as is practicable, pipes are not to be installed directly above or in front of or behind switchboards, section boards and distribution boards. If such placing is unavoidable, suitable protection is to be provided in these positions, see *Pt 5, Ch 13, 2 Construction and installation*.

7.16.5 For switchgear and controlgear assemblies, for rated voltages above 1 kV, arrangements are to be made to protect personnel in the event of gases or vapours escaping under pressure as the result of arcing due to an internal fault. Where personnel may be in the vicinity of the equipment when it is energised, this may be achieved by an assembly that has been tested in accordance with Annex A of IEC 62271-200:2011: *High-voltage switchgear and controlgear – Part 200: AC metal-enclosed switchgear and controlgear for rated voltages above 1 kV and up to and including 52 kV* and qualified for classification **IAC** (internal arc classification).

7.17 Switchboard auxiliary power supplies

7.17.1 Where the operation of a protective device relies upon a power supply, an alarm is to be provided to indicate failure of the power supply, unless its failure causes automatic tripping of the protected circuit.

7.18 Testing

7.18.1 Tests in accordance with *Pt 6, Ch 2, 7.18 Testing 7.18.2* to *Pt 6, Ch 2, 7.18 Testing 7.18.4* are to be satisfactorily carried out on all assemblies, complete or in sections, at the manufacturer's premises, and a test report issued by the manufacturer, see also *Pt 6, Ch 2, 1.4 Surveys 1.4.2*.

7.18.2 A high voltage test, see *Pt 6, Ch 2, 21 Testing and trials*.

7.18.3 Calibration of protective devices and indicating instruments is to be verified by means of current and/or voltage injection.

7.18.4 Demonstration of the satisfactory operation of protection circuits, control circuits and interlocks by means of simulated functional tests.

7.18.5 For switchgear and controlgear assemblies, for rated voltages above 1 kV, type tests are to be carried out, in accordance with Annex A of IEC 62271-200:2011: *High-voltage switchgear and controlgear – Part 200: AC metal-enclosed switchgear and controlgear for rated voltages above 1 kV and up to and including 52 kV* and IAC (internal arc classification) assigned, to verify that the assembly will withstand the effects of an internal arc occurring within the enclosure at a prospective fault level equal to, or in excess of, that of the installation.

7.19 Disconnectors and switch-disconnectors

7.19.1 Disconnectors, switch-disconnectors and their components are to comply with one of the following standards, amended where necessary for ambient temperature and other environmental conditions:

- (a) IEC 60947-3: *Low-voltage switchgear and controlgear – Part 3: Switches, disconnectors, switch-disconnectors and fuse-combination units*;

-
- (b) IEC 62271-102: *High-voltage switchgear and controlgear – Part 102: High-voltage alternating current disconnectors and earthing switches*;
- (c) acceptable and relevant National Standard.

Type test reports to verify the characteristics of a disconnector or switch-disconnector are to be submitted for consideration when required.

■ Section 8 Protection from electric arc hazards within electrical equipment

8.1 General

8.1.1 An assessment is to be carried out in accordance with *Pt 6, Ch 2, 8.2 Hazard identification and assessment 8.2.1* for all electrical equipment within which an arcing fault could occur, such as:

- harmonic filters;
- motor starter panels;
- semiconductor converters;
- switchboards, section boards and distribution boards; or
- transformers.

8.2 Hazard identification and assessment

8.2.1 An assessment is to be carried out to identify the hazards and their consequences for personnel resulting from electric arcs within the electrical equipment identified in *Pt 6, Ch 2, 8.1 General 8.1.1*. The purpose of the assessment is to demonstrate that the design incorporates adequate measures to reduce the risk of injury to personnel should an arcing fault occur within the electrical equipment, and that this will help to ensure both personnel and ship safety.

Details of the following are to be submitted:

- (a) each task to be performed, e.g. switching, equipment maintenance, instrument observation or cleaning;
- (b) the hazards to personnel that could result from an electric arc occurring during each task, and the hazards to personnel that could result from the electric arc;
- (c) the methods to be used to help to prevent electric arcs; and
- (d) the methods to be used to protect personnel from hazards resulting from electric arcs within electrical equipment.

8.3 Calculations to be submitted

8.3.1 The following calculations are to be conducted and used in the hazard identification and assessment:

- (a) calculations of the maximum current that would flow through an electric arc between each conductor and its adjacent conductor, and between each conductor and the exposed conductive parts of the enclosure, in the case of an arcing fault;
- (b) the maximum incident energy at the intended working distance in the case of an arcing fault; and
- (c) the distance from each conductor at which the incident energy would be 5 Joules (1,2 calories) per centimetre squared in the case of an arcing fault when the enclosure door is open.

These calculations may be made in accordance with a relevant Standard acceptable to LR, for example, IEEE Standard 1584, *IEEE Guide for Performing Arc-Flash Hazard Calculations*.

8.4 Testing and trials

8.4.1 It is to be demonstrated that, where provided, arrangements to detect arcing faults function correctly.

■ *Section 9*

Rotating machines**9.1 General requirements**

9.1.1 Rotating machines are to comply with the relevant parts of IEC 60092: *Electrical installations in ships*, or an acceptable and relevant National Standard, and the requirements of this Section.

9.1.2 For all the rotating machines a manufacturer's test certificate is to be provided, see also *Pt 6, Ch 2, 1.4 Surveys 1.4.2 to Pt 6, Ch 2, 1.4 Surveys 1.4.4*.

9.1.3 All machines of 100 kW and over, intended for essential services, are to be surveyed by the Surveyor during manufacture and test.

9.1.4 Shaft materials for rotating machines for essential services are to comply with the *Rules for the Manufacture, Testing and Certification of Materials, July 2015* (hereinafter referred to as the Rules for Materials) and be manufactured under LR survey for the following applications:

- (a) shaft material for dynamic positioning and electric propulsion motors;
- (b) shaft material for main engine driven generators where the shaft is part of the propulsion shafting; and
- (c) shaft material for machines with power ratings of 250 kW or greater.

Shaft material for machines with power ratings less than 250 kW is to have a manufacturer's certificate as detailed in *Ch 1 General Requirements* of the Rules for Materials.

9.1.5 Where welding is applied to shafts of machines for securing arms or spiders, stress relieving is to be carried out after welding. The finalised assembly is to be visually examined by the Surveyors, crack detection carried out by an appropriate method and the finished welds found sound and free from cracks.

9.1.6 The rotating parts of machines are to be so balanced that when running at any speed in the normal working range the vibration does not exceed the levels of IEC 60034-14: *Rotating electrical machines – Part 14: Mechanical vibration of certain machines with shaft heights 56 mm and higher – Measurement, evaluation and limits of vibration severity*.

9.1.7 The lubrication arrangement for bearings are to be effective under all operating conditions including the maximum ship inclinations defined by *Pt 6, Ch 2, 1.10 Inclination of ship* and there are to be effective means provided to ensure that lubricant does not reach the machine windings or other conductors and insulators.

9.1.8 Means are to be taken to prevent the ill effects of the flow of currents circulating between the shaft and machine bearings or bearings of connected machinery.

9.1.9 Alternating current machines are to be constructed such that, under any operating conditions, they are capable of withstanding the effects of a sudden short-circuit at their terminals without damage.

9.1.10 Propulsion motors, and generators that form part of electrical propulsion systems, are to have at least one embedded temperature detector (ETD) in each phase of the machine winding in locations which may be subjected to the highest temperature. Where there are two coil sides per slot the ETD's are to be located between the insulated coil sides in the slot, see *Pt 6, Ch 2, 16.1 General 16.1.3*.

9.1.11 A high bearing temperature alarm is to be provided for generators of 100 kW and above, and electric propulsion motors, which are supplied with forced lubrication.

9.1.12 A low lubricating oil pressure alarm is to be provided for generators and electric propulsion motors that are supplied with forced lubrication.

9.1.13 A high lubricating oil temperature alarm is to be provided for electric propulsion motors that are supplied with forced lubrication.

9.1.14 For high voltage machines, the stator insulation system is to be of a type that has undergone sample testing in accordance with the following International Standards, or relevant alternatives acceptable to LR, to demonstrate its suitability for the operating voltage in the presence of an LR Surveyor:

- (a) IEC 60894, *Guide for a test procedure for the measurement of loss tangent of coils and bars for machine windings*, at the insulation class rated temperature; and

- (b) IEC 60034-15: *Rotating electrical machines – Part 15: Impulse voltage withstand levels of form-wound stator coils for rotating a.c. machines*, with power-frequency voltage withstand testing conducted.

Test samples are to be representative in terms of the number and size of conductors, coil construction, combination of materials and manufacturing process.

9.1.15 For testing required by *Pt 6, Ch 2, 9.1 General requirements 9.1.14* on coils relating to global vacuum pressure impregnated systems, test samples representing the unimpregnated state and the impregnated state of the final winding and stator core are to be used as appropriate for testing.

9.2 Rating

9.2.1 Generators, including their excitation systems, and continuously rated motors are to be suitable for continuous duty at their full rated output at maximum cooling air or water temperature for an unlimited period, without the limits of temperature rise in *Pt 6, Ch 2, 9.3 Temperature rise* being exceeded. Generators are to be capable of an overload power of not less than 10 per cent at their rated power factor for a period of 15 minutes without injurious heating. Other machines are to be rated in accordance with the duty which they have to perform and, when tested under rated load conditions, the temperature rise is not to exceed the values in *Pt 6, Ch 2, 9.3 Temperature rise*.

9.2.2 When a rotating machine is connected to a supply system with harmonic distortion the rating of the machine is to allow for the increased heating effect of the harmonic loading.

9.2.3 The design and construction of smoke extraction fan motors are to be suitable for the ambient temperature and operating time required. Type test reports to verify the performance of the electric motor are to be submitted for consideration.

9.3 Temperature rise

9.3.1 The limits of temperature rise specified in *Table 2.9.1 Limits of temperature rise of machines cooled by air*, are based on the cooling air temperature and cooling water temperature given in *Pt 6, Ch 2, 1.9 Ambient reference and operating conditions*.

9.3.2 If it is known that the temperature of cooling medium exceeds the values given in *Pt 6, Ch 2, 1.9 Ambient reference and operating conditions* the permissible temperature rise is to be reduced by an amount equal to the excess temperature of the cooling medium.

9.3.3 If it is known that the temperature of cooling medium will be permanently less than the values given in *Pt 6, Ch 2, 1.9 Ambient reference and operating conditions* the permissible temperature rise may be increased by an amount equal to the difference between the declared temperature and that given in *Pt 6, Ch 2, 1.9 Ambient reference and operating conditions* up to a maximum of 15°C.

9.4 Generator control

9.4.1 Each alternating current generator, unless of the self-regulating type, is to be provided with automatic means of voltage regulation; voltage build-up is not to require an external source of power. Provision is to be made to safeguard the distribution system should there be a failure of the voltage regulating system resulting in a high voltage.

9.4.2 The voltage regulation of any alternating current generator with its regulating equipment is to be such that at all loads, from zero to full load at rated power factor, the rated voltage is maintained within $\pm 2,5$ per cent under steady conditions. There is to be provision at the voltage regulator to adjust the generator no load voltage.

9.4.3 Generators, and their excitation systems, when operating at rated speed and voltage on no-load are to be capable of absorbing the suddenly switched, balanced, current demand of the largest motor or load at a power factor not greater than 0,4 with a transient voltage dip which does not exceed 15 per cent of rated voltage. The voltage is to recover to rated voltage within a time not exceeding 1,5 seconds.

Table 2.9.1 Limits of temperature rise of machines cooled by air

Limits of temperature rise of machines cooled by air, °C							
Part of machine	Method of temperature measurement	Insulation class					
		A	E	B	F	H	
1. (a) a.c. windings of machines having output of 5000 kVA or more	ETD	55	–	75	95	115	
	R	50	–	70	90	110	
(b) a.c. windings of machines having output of less than 5000 kVA	ETD	55	–	80	100	115	
	R	50	65	70	95	110	
2. Windings of armatures having commutators	R	50	65	70	95	115	
	T	40	55	60	75	95	
3. Field windings of a.c. and d.c. machines having d.c. excitation other than those in item 4	R	50	65	70	95	115	
	T	40	55	60	75	95	
4. (a) Field windings of synchronous machines with cylindrical rotors having d.c. excitation (b) Stationary field windings of d.c. machines having more than one layer (c) Low resistance field windings of a.c. and d.c. machines and compensating windings of d.c. machines having more than one layer (d) Single-layer windings of a.c. and d.c. machines with exposed bare or varnished metal surfaces and single-layer compensating windings of d.c. machines	R	–	–	80	100	125	
	R	50	65	70	95	115	
	T	40	55	60	75	95	
	R, T	50	65	70	90	115	
5. Permanently short-circuited insulated windings	T	50	65	70	90	115	
	T	The temperature rise of these parts shall in no case reach such a value that there is a risk to any insulation or other materials on adjacent parts or to the item itself					
T							
8. Magnetic cores and other parts in contact with windings	T	50	65	70	90	110	

9.	Commutators and slip-rings open and enclosed	T	50	60	70	80	90
----	--	---	----	----	----	----	----

Note 1. Where water cooled heat exchangers are used in the machine cooling circuit the temperature rises are to be measured with respect to the temperature of the cooling water at the inlet to the heat exchanger and the temperature rises given in this Table shall be increased by 10°C provided the inlet water temperature does not exceed the values given in Pt 6, Ch 2, 1.9 Ambient reference and operating conditions.

Note 2. T = thermometer method
R = resistance method
ETD = embedded temperature detector.

Note 3. Temperature rise measurements are to use the resistance method whenever practicable.

Note 4. The ETD method may only be used when the ETD's are located between coil sides in the slot.

9.4.4 The transient voltage rise at the terminals of a generator is not to exceed 20 per cent of rated voltage when rated kVA at a power factor not greater than 0,8 is thrown off.

9.4.5 Generators and their voltage regulation systems are to be capable of maintaining, without damage, under steady state short-circuit conditions a current of at least three times the full load rated current for a duration of at least two seconds or where precise data is available for the duration of any time delay which may be provided by a tripping device for discrimination purposes.

9.4.6 Generators required to run in parallel are to be stable from no load (kW) up to the total combined full load (kW) of the group, and load sharing is to be such that the load on any generator does not normally differ from its proportionate share of the total load by more than 15 per cent of the rated output (kW) of the largest machine or 25 per cent of the rated output (kW) of the individual machine, whichever is less.

9.4.7 When generators are operated in parallel, the kVA loads of the individual generating sets are not to differ from the proportionate share of the total kVA load by more than 5 per cent of the rated kVA output of the largest machines.

9.5 Overloads

9.5.1 Machines are to withstand on test, without injury, the following momentary overloads:

- (a) **Generators.** An excess current of 50 per cent for 15 seconds after attaining the temperature rise corresponding to rated load, the terminal voltage being maintained as near the rated value as possible. The foregoing does not apply to the overload torque capacity of the prime mover.
- (b) **Motors.** At rated speed or, in the case of a range of speeds, at the highest and lowest speeds, under gradual increase of torque, the appropriate excess torque given below. Synchronous motors and synchronous induction motors are required to withstand the excess torque without falling out of synchronism and without adjustment of the excitation circuit preset at the value corresponding to rated load:

d.c. motors	50 per cent for 15 seconds;
polyphase a.c.	
synchronous motors	50 per cent for 15 seconds;
polyphase a.c.	
synchronous	
induction motors	35 per cent for 15 seconds;
polyphase a.c.	
induction motors	60 per cent for 15 seconds.

- (c) **Propulsion machines.** The overload tests for propulsion machines will be specially considered for each installation.
- (d) **Windlasses.** For the design and testing of windlass electric motors, see Pt 3, Ch 13, 8.8 Winch design and testing.

9.6 Machine enclosure

9.6.1 Where liquid-cooled heat exchangers are used in the machine cooling circuit there is to be provision to detect leakage of the liquid, and the system is to be arranged so as to prevent the entry of liquid into the machine.

9.7 Direct current machines

9.7.1 The final running position of brushgear is to be clearly and permanently marked.

9.7.2 Direct current machines are to work with fixed brush setting from no load to the momentary overload specified without injurious sparking.

9.8 Survey and testing

9.8.1 On machines for essential services tests are to be carried out and a certificate furnished by the manufacturer. The tests are to include temperature rise, momentary overload, high voltage, and commutation. The insulation resistance and the temperature at which it was measured are to be recorded, see also *Pt 6, Ch 2, 1.4 Surveys 1.4.2* to *Pt 6, Ch 2, 1.4 Surveys 1.4.4*

9.8.2 In the case of duplicate machines, type tests of temperature rise, excess current and torque and commutation taken on a machine identical in rating and in all other essential details may be accepted in conjunction with abbreviated tests on each machine. Type tests for propulsion machines will be specially considered, see also *Pt 6, Ch 2, 16 Electric propulsion*. For the abbreviated tests, each machine is to be run and is to be found electrically and mechanically sound and is to have a high voltage test and insulation resistance recorded.

9.8.3 A high voltage test, in accordance with *Pt 6, Ch 2, 21 Testing and trials*, is to be applied to new machines, preferably at the conclusion of the temperature rise test. Where both ends of each phase are brought out to accessible separate terminals each phase is to be tested separately.

9.8.4 Survey during manufacture, see *Pt 6, Ch 2, 1.4 Surveys*, is to be conducted prior to testing of the completed machine and is to include inspection of rotor and stator assemblies to assess compliance with the constructional requirements of the relevant standards and this Section.

9.8.5 For high voltage machines, a description of rotor and stator insulation system application procedures (taping, impregnation, pressing and curing, etc.) with application process records, including details of checks and tests conducted to verify successful application, is to be made available to the LR Surveyor during manufacture, see also *Pt 6, Ch 2, 9.1 General requirements 9.1.14*.

9.8.6 Routine impulse tests are to be carried out on the coils of high voltage machines in accordance with IEC 60034-15: *Rotating electrical machines – Part 15: Impulse voltage withstand levels of form-wound stator coils for rotating a.c. machines*, in order to demonstrate a satisfactory withstand level of the inter-turn insulation to voltage surges. The test is to be carried out on all coils after they have been inserted in the slots and after wedging and bracing. Each coil shall be subjected to at least five impulses of injected voltage, the peak value of the injected voltage being given by the formula:

$$V_{\text{peak}} = 2,45V$$

where

$$V = \text{rated line voltage r.m.s.}$$

Alternative proposals to demonstrate the withstand level of inter-turn insulation will be considered.

■ *Section 10*
Converter equipment

10.1 Transformers

10.1.1 Paragraphs *Pt 6, Ch 2, 10.1 Transformers 10.1.2* to *Pt 6, Ch 2, 10.1 Transformers 10.1.13* apply to transformers rated for 5 kVA upwards.

10.1.2 Transformers are to comply with the requirements of the following standards:

- (a) IEC 60076 (all parts); *Power transformers* (all parts);
- (b) IEC 60092-503: *Electrical installations in ships – Part 503: Special features – AC supply systems with voltages in the range of above 1 kV up to and including 15 kV*; or
- (c) an acceptable and relevant National Standard amended where necessary for ambient temperature, see *Pt 6, Ch 2, 1.9 Ambient reference and operating conditions*.

10.1.3 Transformers may be of the dry type, encapsulated or liquid-filled type.

10.1.4 The temperature rise of the winding of transformers above the ambient temperatures given in *Pt 6, Ch 2, 1.9 Ambient reference and operating conditions*, when measured by resistance during continuous operation at the maximum rating, is not to exceed:

(a) For dry type transformers, air cooled:

insulation of Class A - 50°C

insulation of Class E - 60°C

insulation of Class B - 70°C

insulation of Class F - 90°C

insulation of Class H - 110°C

(b) For liquid filled transformers:

50°C - where air provides cooling of the fluid

65°C - where water provides cooling of the fluid.

10.1.5 When a transformer is connected to a supply system with harmonic distortion, the rating of the transformer is to allow for the increased heating effect of the harmonic loading. Special attention is to be given to transformers connected for the purpose of reducing harmonic distortion.

10.1.6 The inherent regulation of transformers at their rated output is to be such that the total voltage drop to any point in the installation does not exceed that allowed by *Pt 6, Ch 2, 1.8 Quality of power supplies*.

10.1.7 Transformers, except those for motor starting, are to be double wound.

10.1.8 Liquid fillings for transformers are to be non-toxic and of a type which does not readily support combustion. Liquid filled transformers are to have a pressure relief device with an alarm and there is to be a suitable means provided to contain any liquid which may escape from the transformer due to the operation of the relief device or damage to the tank.

10.1.9 All transformers are to be capable of withstanding for two seconds, without damage, the thermal and mechanical effects of a short-circuit at the terminals of any winding.

10.1.10 When forced cooling is used, whether air or liquid, there is to be monitoring of the cooling medium and transformer winding temperatures with an alarm should these exceed preset limits. There are to be arrangements so that the load may be reduced to a level commensurate with the cooling available.

10.1.11 Transformers for propulsion power are to be provided with arrangements such that, in the event of excessive winding temperature, an alarm is initiated and:

- the load is reduced to a level commensurate with the cooling arrangements; or
- automatic shutdown of the transformer occurs.

10.1.12 Where liquid-cooled heat exchangers are used in transformer cooling circuits, there is to be provision to detect leakage of the liquid, and the system is to be arranged so as to prevent the entry of liquid into the transformer.

10.1.13 The following tests are to be carried out on all transformers at the manufacturer's works, and a certificate of tests issued by the manufacturer, see also *Pt 6, Ch 2, 1.4 Surveys 1.4.2* and *Pt 6, Ch 2, 1.4 Surveys 1.4.3*:

- (a) measurement of winding resistances, voltage ratio, impedance voltage, short-circuit impedance, insulation resistance, load loss, no load loss and current;
- (b) dielectric tests;
- (c) temperature rise test on one transformer of each size and type; and
- (d) where evidence of compliance with *Pt 6, Ch 2, 10.1 Transformers 10.1.9* is not submitted for consideration, short-circuit withstand on one transformer of each size and type.

10.2 Semiconductor converters

10.2.1 The requirements of *Pt 6, Ch 2, 10.2 Semiconductor converters 10.2.2* to *Pt 6, Ch 2, 10.2 Semiconductor converters 10.2.18* apply to semiconductor converters rated for 5 kW upwards.

10.2.2 Semiconductor converters are to comply with the requirements of IEC 60146 (all parts): *Semiconductor converters*, or an acceptable and relevant National Standard amended where necessary for ambient temperature, see *Pt 6, Ch 2, 1.9 Ambient reference and operating conditions*.

10.2.3 Semiconductor static power converters are to be rated for the required duty having regard to peak loads, system transients and overvoltage.

10.2.4 Converter equipment may be air or liquid cooled and is to be so arranged that it cannot remain loaded unless effective cooling is maintained. Alternatively the load may be automatically reduced to a level commensurate with the cooling available.

10.2.5 Liquid cooled converter equipment is to be provided with leakage alarms and there is to be a suitable means provided to contain any liquid which may leak from the system in order to ensure that it does not cause an electrical failure of the equipment. Where the semiconductors and other current carrying parts are in direct contact with the cooling liquid, the liquid is to be monitored for satisfactory resistivity and an alarm initiated at the relevant control station should the resistivity be outside the agreed limits.

10.2.6 Where forced cooling is used there is to be temperature monitoring of the heated cooling medium with an alarm and shutdown when the temperature exceeds a preset value.

10.2.7 Cooling fluids are to be non-toxic and of low flammability.

10.2.8 Converter equipment is to be so arranged that the semiconductor devices, fuses, control and firing circuit boards may be readily removed from the equipment for repair or replacement.

10.2.9 Test and monitoring facilities are to be provided to permit identification of control circuit faults and faulty components.

10.2.10 Protection devices fitted for converter equipment protection are to ensure that, under fault conditions, the protective action of circuit-breakers, fuses or control systems is such that there is no further damage to the converter or the installation.

10.2.11 Converter equipment, including any associated transformers, reactors, capacitors and filters, if provided, is to be so arranged that the harmonic distortion, and voltage spikes, introduced in to the ships electrical system are within the limits of *Pt 6, Ch 2, 1.8 Quality of power supplies 1.8.3* or restricted to a lower level necessary to ensure that it causes no malfunction of equipment connected to the electrical installation.

10.2.12 Overvoltage spikes or oscillations caused by commutation or other phenomena, are not to result in the supply voltage waveform deviating from a superimposed equivalent sine wave by more than 10 per cent of the maximum value of the equivalent sine wave.

10.2.13 When converter equipment is operated in parallel, load sharing is to be such that under normal operating conditions overloading of any unit does not occur and the combination of paralleled equipment is stable throughout the operating range.

10.2.14 When converter equipment has parallel circuits there is to be provision to ensure that the load is distributed uniformly between the parallel paths.

10.2.15 Transformers, reactors, capacitors and other circuit devices associated with converter equipment, or associated filters, are to be suitable for the distorted voltage and current waveforms to which they may be subjected and filter circuits are to be provided with facilities to ensure that their capacitors are discharged before the circuits are energised.

10.2.16 Any regenerated power developed during the operation of converter equipment is not to result in disturbances to the supply system voltage and frequency which exceeds the limits of *Pt 6, Ch 2, 1.8 Quality of power supplies*.

10.2.17 Where control systems form an integral part of semiconductor equipment, they are to be designed and manufactured with regard to the environmental conditions to which they will be exposed in service and their performance is to be demonstrated during the test and trials programme.

10.2.18 Tests at the manufacturer's works of converter equipment and any associated reactors or filters are to include the high voltage test of 20.1, a temperature rise test, on one of each size and type of converter equipment, and such other tests as may be necessary to demonstrate the suitability of the equipment for its intended duty. Details of tests are to be submitted for consideration when required, see also *Pt 6, Ch 2, 1.4 Surveys 1.4.2*.

10.3 Uninterruptible power systems

10.3.1 The requirements of this sub-Section apply to all uninterruptible power systems (UPS) intended to maintain essential services or provide emergency services. This sub-Section is in addition to the requirements of *Pt 6, Ch 2, 10.1 Transformers* to *Pt 6, Ch 2, 10.2 Semiconductor converters* and *Pt 6, Ch 2, 12 Batteries*, as applicable.

10.3.2 UPS units are to be constructed in accordance with IEC 62040: *Uninterruptible power systems (UPS)* (all parts), or an acceptable and relevant National or International Standard.

10.3.3 The operation of a UPS is not to depend upon external services.

10.3.4 The type of UPS unit employed, whether off-line, line-interactive or on-line, is to be appropriate to the power supply requirements of the connected load equipment.

10.3.5 An external bypass, that is hardwired and manually operated, is to be provided for UPS to allow isolation of UPS for safety during maintenance and maintain continuity of load power.

10.3.6 UPS units are to be monitored and an audible and visual alarm is to be initiated in the navigating bridge or the engine control room, or an equivalent attended location for:

- power supply failure (voltage and frequency) to the connected load;
- earth fault;
- operation of battery protective device;
- battery discharge; and
- bypass in operation for on-line UPS units.

10.3.7 UPS units required to provide emergency services are to be suitably located for use in an emergency.

10.3.8 UPS units utilising valve-regulated sealed batteries may be located in compartments with standard marine or industrial electrical equipment provided that the arrangements comply with *Pt 6, Ch 2, 12.3 Location 12.3.5*. Ventilation arrangements in accordance with IEC 62040-1: *Uninterruptible power systems (UPS) – Part 1: General and safety requirements for UPS*, or an acceptable and relevant National or International Standard, may be considered to satisfy the requirements of *Pt 6, Ch 2, 12.5 Ventilation 12.5.10*.

10.3.9 Output power is to be maintained for the duration required for the connected equipment.

10.3.10 The UPS battery capacity is, at all times, to be capable of supplying the designated loads for the time specified. Where it is proposed that additional circuits are connected to the UPS unit, details verifying that the UPS unit has adequate capacity are to be submitted for consideration, see *Pt 6, Ch 2, 1.5 Additions or alterations*.

10.3.11 On restoration of the input power, the rating of the charge unit is to be sufficient to recharge the batteries while maintaining the output supply to the load equipment.

10.3.12 Tests at the manufacturer's works or after installation on board are to include such tests necessary to demonstrate, to the Surveyor's satisfaction, the suitability of the UPS unit for its intended duty and location. As a minimum the following tests are required:

- a temperature rise test;
- battery capacity test;
- a ventilation rate test of both the equipment housing and the space into which it is to be located, see also *Pt 6, Ch 2, 12.5 Ventilation*; and
- functional testing, including operation of alarms.

Details of tests are to be submitted for consideration when required, see also *Pt 6, Ch 2, 1.4 Surveys 1.4.2*.

10.3.13 Where the supply is to be maintained without a break following a power input failure, this is to be verified after installation by practical testing.

■ Section 11

Electric cables, optical fibre cables and busbar trunking systems (busways)

11.1 General

11.1.1 The requirements of *Pt 6, Ch 2, 11.1 General* to *Pt 6, Ch 2, 11.16 Joints and branch circuits in cable systems* apply to all electric and optical fibre cables for fixed wiring unless otherwise exempted. The requirements of *Pt 6, Ch 2, 11.17 Busbar trunking systems (bustrunks)* apply to busbar trunking systems (busways) where they are used in place of electric cables.

11.1.2 Electric cables for fixed wiring are to be designed, manufactured and tested in accordance with the relevant IEC Standard stated in *Table 2.11.1 Electric cables* or an adequate and relevant National Standard.

11.1.3 Details of optical fibre cables for fixed installation are to be submitted to assess compliance with applicable international or National Standards. These are to include:

- Flame retardancy;
- Fire resistance (if applicable);
- Smoke density;
- Halogen content;
- Mechanical properties;

Suitability for use in the marine environment.

11.1.4 Electric cables for electric propulsion systems are to be Type Approved in accordance with LR's *Type Approval System Test Specification Number 3* or, alternatively, surveyed by the Surveyors during manufacture and testing to assess compliance with the applicable International or National Standards and application of an acceptable quality management system.

11.1.5 Provided that adequate flexibility of the finished cable is assured, conductors of nominal cross-section area 2,5 mm² and less need not be stranded.

11.1.6 Electric and optical fibre cables for non-fixed applications are to comply with a relevant national or international Standard.

11.1.7 For the purpose of this Section, pipes, conduits, trunking or any other system for the additional mechanical protection of cables are hereafter referred to under the generic name 'protective casings'.

11.1.8 Electrical cables for telecommunications and data transfer are, whenever practicable, to be selected in accordance with the recommendations of IEC TR 60092-370: *Guidance on the selection of cables for telecommunication and data transfer including radio-frequency cables*.

Table 2.11.1 Electric cables

Application	IEC Standard	Title
General constructional and testing requirements	60092-350	Electrical installations in ships – Part 350: General construction and test methods of power, control and instrumentation cables for shipboard and offshore applications
Fixed power and control circuits	60092-353	Electrical installations in ships – Part 353: Power cables for rated voltages 1 kV and 3 kV
Fixed power circuits	60092-354	Electrical installations in ships – Part 354: Single- and three-core power cables with extruded solid insulation for rated voltages 6 kV (Um = 7,2 kV) up to 30 kV (Um = 36 kV)
Instrumentation, control and communication circuits up to 60 V	60092-370	Electrical installations in ships – Part 370: Guidance on the selection of cables for telecommunication and data transfer including radio-frequency cables
Control circuits and instrumentation up to 250 V	60092-376	Electrical installations in ships – Part 376: Cables for control and instrumentation circuits 150/250 V (300 V)
Mineral insulated	60702 (all parts)	Mineral insulated cables and their terminations with a rated voltage not exceeding 750 V

11.2 Testing

11.2.1 Routine tests, consisting of at least:

- (a) measurement of electrical resistance of conductors;
- (b) high voltage test, *see also Pt 6, Ch 2, 21 Testing and trials*;

- (c) insulation resistance measurement;
- (d) for high voltage cables, partial discharge tests are to be made in accordance with the requirements of IEC 60885-2: *Electrical test methods for electric cables – Part 2: Partial discharge tests*, or an acceptable and relevant National Standard, at the manufacturer's works prior to despatch.

Evidence of successful completion of routine tests is to be provided by the manufacturer, see also *Pt 6, Ch 2, 11.1 General 11.1.4*.

11.2.2 Particular, special and type tests are to be made, when required, in accordance with the requirements of the relevant publication or National Standard referred to in *Pt 6, Ch 2, 11.1 General 11.1.2* and a test report issued by the manufacturer.

11.3 Voltage rating

11.3.1 The rated voltage of any electric cable is to be not lower than the nominal voltage of the circuit for which it is used. The maximum sustained voltage of the circuit is not to exceed the maximum voltage for which the cable has been designed.

11.3.2 Electric cables used in unearthed systems are to be suitably rated to withstand the additional stresses imposed on the insulation due to an earth fault.

11.4 Operating temperature

11.4.1 The maximum rated conductor temperature of the insulating material for normal operation is to be at least 10°C higher than the maximum ambient temperature liable to be produced in the space where the cable is installed.

11.4.2 The maximum rated conductor temperatures for normal and short-circuit operation, for the insulating materials included within the standards referred to in *Pt 6, Ch 2, 11.1 General 11.1.2* is not to exceed the values stated in *Table 2.11.2 Maximum rated conductor temperature*.

Table 2.11.2 Maximum rated conductor temperature

Type of insulating compound	Maximum rated conductor temperature, °C		
	Abbreviated designation	Normal operation	Short-circuit
Elastomeric or thermosetting, based upon:			
Ethylene-propylene rubber or similar (EPM or EPDM)	EPR	90	250
High modulus or hard grade ethylene propylene rubber	HEPR	90	250
Cross-linked polyethylene	XLPE	90	250
Cross-linked polyolefin material for halogen-free cables	HF90	90	250
Silicone rubber	S95	95	350

11.4.3 Electric cables constructed of an insulating material not included in *Table 2.11.2 Maximum rated conductor temperature* are to be rated in accordance with the National Standard chosen in compliance with *Pt 6, Ch 2, 11.1 General 11.1.2*.

11.5 Construction

11.5.1 Electric and optical fibre cables are to be at least of a flame-retardant type. IEC 60332-1-2: *Tests on electric and optical fibre cables under fire conditions – Part 1-2: Test for vertical flame propagation for a single insulated wire or cable – Procedure for 1 kW pre-mixed flame*, will be acceptable.

11.5.2 Exemption from the requirements of *Pt 6, Ch 2, 11.5 Construction 11.5.1* for applications such as radio frequency or digital communication systems, which require the use of particular types of cable, will be subject to special consideration.

11.5.3 Where electric and optical fibre cables are required to be of a 'fire resistant type', they are in addition to be easily distinguishable and comply with the performance requirements of the appropriate part of IEC 60331: *Tests for electric cables under fire conditions – Circuit integrity*, when tested with a minimum flame application time of 90 minutes, as follows:

- IEC 60331-1: *Tests for electric cables under fire conditions – Circuit integrity – Part 1: Test method for fire with shock at a temperature of at least 830 degrees C for cables of rated voltage up to and including 0,6/1,0 kV and with an overall diameter exceeding 20 mm.*

- IEC 60331-2: *Tests for electric cables under fire conditions – Circuit integrity – Part 2: Test method for fire with shock at a temperature of at least 830 Degrees C for cables of rated voltage up to and including 0,6/1,0 kV and with an overall diameter not exceeding 20 mm;*
- IEC 60331-21: *Tests for electric cables under fire conditions – Circuit integrity – Part 21: Procedures and requirements – Cables of rated voltage up to and including 0,6/1,0 kV;*
- IEC 60331-23: *Tests for electric cables under fire conditions – Circuit integrity – Part 23: Procedures and requirements – Electric data cables; or*
- IEC 60331-25: *Tests for electric cables under fire conditions – Circuit integrity – Part 25: Procedures and requirements – Optical fibre cables.*

11.5.4 Where electric or optical fibre cables are installed in locations exposed to the weather, in damp and in wet situations, in machinery compartments, refrigerated spaces or exposed to harmful vapours including oil vapour they are to have the conductor insulating materials or optical fibres enclosed in an impervious sheath of material appropriate to the expected ambient conditions.

11.5.5 Where electric or optical fibre cables are installed in locations which are totally submerged for extended periods of time, they are to have the conductor insulating materials or fibres enclosed in an impervious sheath of material appropriate to the expected submerged conditions and duration.

11.5.6 Where it is required that the construction of electric or optical fibre cables includes metallic sheaths, armouring or braids, they are to be provided with an overall impervious sheath or other means to protect the metallic elements against corrosion, see also Pt 6, Ch 2, 11.8 *Installation of electric cables* 11.8.7 and Pt 6, Ch 2, 11.8 *Installation of electric cables* 11.8.8.

11.5.7 Where cables are installed in an area where contamination by oil is likely to occur, the oversheath is to be of an enhanced oil resistance grade.

11.5.8 Where single core electric cables are used in circuits rated in excess of 20 Amps and are armoured the armour is to be of a non-magnetic material.

11.5.9 Electric cables are to be constructed such that they are capable of withstanding the mechanical and thermal effects of the maximum short-circuit current which can flow in any part of the circuit in which they are installed, taking into consideration not only the time/current characteristics of the circuit protective device but also the peak value of the prospective short-circuit current. Where electric cables are to be used in circuits with a maximum short-circuit current in excess of 70 kA, evidence is to be submitted for consideration when required demonstrating that the cable construction can withstand the effects of the short-circuit current.

11.5.10 All high voltage electric cables are to be readily identified by suitable marking.

11.6 Conductor size

11.6.1 The maximum continuous load carried by a cable is not to exceed its continuous current rating. It is to be chosen such that the maximum rated conductor temperature for normal operation for the insulation is not exceeded. In assessing the current rating the correction factors in Pt 6, Ch 2, 11.7 *Correction factors for cable current rating* may be applied as required.

11.6.2 The cross-sectional area of the conductors is to be sufficient to ensure that, under short-circuit conditions, the maximum rated conductor temperature for short-circuit operation is not exceeded, taking into consideration the time current characteristics of the circuit protective device and the peak value of the prospective short-circuit current.

11.6.3 The cable current ratings given in Table 2.11.3 *Electric cable current ratings, normal operation, based on ambient 45°C* and Table 2.11.4 *Electric cable current ratings, r.m.s. short-circuit current* are based on the maximum rated conductor temperatures given in Table 2.11.2 *Maximum rated conductor temperature*. When cable sizes are selected on the basis of precise evaluation of current rating based upon experimental and calculated data, details are to be submitted for consideration. Alternative short-circuit temperature limits, other than those given in Table 2.11.4 *Electric cable current ratings, r.m.s. short-circuit current*, may be applied using the data provided in:

- IEC 60724: *Short-circuit temperature limits of electric cables with rated voltages of 1kV ($U_m=1,2kV$) and 3kV ($U_m=3,6kV$); or*
- IEC 60986: *Short-circuit temperature limits of electric cables with rated voltages from 6kV ($U_m=7,2kV$) and up to 30kV ($U_m=36kV$).*

Alternative short-circuit temperature limits provided in an acceptable and relevant National Standard may also be considered.

11.6.4 The cross-sectional area of the conductors is to be sufficient to ensure that at no point in the installation will the voltage variations stated in Pt 6, Ch 2, 1.8 *Quality of power supplies* be exceeded when the conductors are carrying the maximum current under their normal conditions of service.

11.6.5 The size of earth conductors is to comply with *Pt 6, Ch 2, 1.12 Earthing of non-current carrying parts 1.12.8.*

Table 2.11.3 Electric cable current ratings, normal operation, based on ambient 45°C

Nominal cross-section (mm ²)	Continuous r.m.s. current rating, in amperes					
	Elastomeric (90°C)			Elastomeric or thermosetting, based on silicon rubber (95°C)		
	Single Core	2 core	3 or 4 core	Single Core	2 core	3 or 4 core
0,75	15	13	11	17	14	12
1	18	15	13	20	17	14
1,25	21	18	14	23	20	16
1,5	23	20	16	26	22	18
2	28	24	19	31	26	22
2,5	30	26	21	32	27	22
3,5	37	32	26	39	33	28
4	40	34	28	43	37	30
5,5	49	42	35	52	44	37
6	52	44	36	55	47	39
8	62	53	44	66	56	46
10	72	61	50	76	65	53
14	88	75	62	94	80	66
16	96	82	67	102	87	71
22	117	100	82	124	106	87
25	127	108	89	135	115	95
30	142	121	100	151	128	106
35	157	133	110	166	141	116
38	165	140	116	175	149	122
50	196	167	137	208	177	146
60	220	187	154	233	198	163
70	242	206	169	256	218	179
80	263	224	184	278	237	195
95	293	249	205	310	264	217
100	302	257	212	320	272	224
120	339	288	237	359	305	251
125	348	295	243	368	313	258
150	389	331	272	412	350	288
185	444	377	311	470	400	329
200	466	396	326	494	420	346
240	522	444	365	553	470	387
300	601	511	421	636	541	445

Table 2.11.4 Electric cable current ratings, r.m.s. short-circuit current

Nominal cross-section (mm ²)	Fault current (kA) at 250°C			Fault current (kA) at 350°C		
	1 s duration	0,5 s duration	0,1 s duration	1 s duration	0,5 s duration	0,1 s duration
0,75	0,1	0,2	0,3	0,1	0,2	0,4
1	0,1	0,2	0,5	0,2	0,2	0,5
1,25	0,2	0,3	0,6	0,2	0,3	0,7
1,5	0,2	0,3	0,7	0,3	0,4	0,8
2	0,3	0,4	0,9	0,3	0,5	1,1
2,5	0,4	0,5	1,1	0,4	0,6	1,4
3,5	0,5	0,7	1,6	0,6	0,8	1,9
4	0,6	0,8	1,8	0,7	1,0	2,2
5,5	0,8	1,1	2,5	0,9	1,3	3,0
6	0,9	1,2	2,7	1,0	1,5	3,2
8	1,1	1,6	3,6	1,4	1,9	4,3
10	1,4	2,0	4,5	1,7	2,4	5,4
14	2,0	2,8	6,3	2,4	3,4	7,6
16	2,3	3,2	7,2	2,7	3,9	8,7
22	3,1	4,5	10,0	3,8	5,3	11,9
25	3,6	5,1	11,3	4,3	6,0	13,5
30	4,3	6,1	13,6	5,1	7,3	16,2
35	5,0	7,1	15,8	6,0	8,5	18,9
38	5,4	7,7	17,2	6,5	9,2	20,6
50	7,2	10,1	22,6	8,6	12,1	27,1
60	8,6	12,1	27,1	10,3	14,5	32,5
70	10,0	14,2	31,7	12,0	16,9	37,9
80	11,4	16,2	36,2	13,7	19,4	43,3
95	13,6	19,2	43,0	16,3	23,0	51,4
100	14,3	20,2	45,2	17,1	24,2	54,1
120	17,2	24,3	54,3	20,5	29,0	64,9
125	17,9	25,3	56,6	21,4	30,2	67,6
150	21,5	30,4	67,9	25,7	36,3	81,2
185	26,5	37,4	83,7	31,7	44,8	100,1
200	28,6	40,5	90,5	34,2	48,4	108,2
240	34,3	48,6	108,6	41,1	58,1	129,9
300	42,9	60,7	135,7	51,3	72,6	162,3

11.6.6 The cross-sectional area of conductors used in circuits supplying cyclic or non-continuous loads is to be sufficient to ensure that the cables maximum rated conductor temperature for normal operation is not exceeded when the conductors are operating under their normal conditions of service, see Pt 6, Ch 2, 11.7 Correction factors for cable current rating 11.7.4.

11.7 Correction factors for cable current rating

11.7.1 The correction factors of Pt 6, Ch 2, 11.7 Correction factors for cable current rating 11.7.2 to Pt 6, Ch 2, 11.7 Correction factors for cable current rating 11.7.5 provide a guide for general applications in assessing a current rating. A more precise evaluation based upon experimental and calculated data may be submitted for consideration.

11.7.2 **Bunching of cables.** Where more than six electric cables, which may be expected to operate simultaneously at their full rated capacity, are laid close together in a cable bunch in such a way that there is an absence of free air circulation around them, a correction factor of 0,85 is to be applied. Signal cables may be exempted from this requirement.

11.7.3 **Ambient temperature.** The current ratings of Table 2.11.3 Electric cable current ratings, normal operation, based on ambient 45°C are based on an ambient temperature of 45°C. For other values of ambient temperature the correction factors shown in Pt 6, Ch 2, 11.7 Correction factors for cable current rating 11.7.3 are to be applied.

Table 2.11.5 Correction factors

Insulation material	Correction factor for ambient air temperature of °C										
	35	40	45	50	55	60	65	70	75	80	85
Elastomeric or thermosetting (90°C)	1,10	1,05	1,00	0,94	0,88	0,82	0,74	0,67	0,58	0,47	—
Elastomeric or thermosetting, based on silicone rubber (95°C)	1,10	1,05	1,00	0,95	0,89	0,84	0,77	0,71	0,63	0,55	0,45

11.7.4 **Short time duty.** When the load is not continuous, i.e. operates for periods of half an hour or one hour and the periods of no load are longer than three times the cable's time constant, T in minutes, the cable's continuous rating may be increased by a duty factor, calculated in accordance with:

$$Duty\ factor = \sqrt{\frac{1,12}{1 - e^{-\frac{t_s}{T}}}}$$

When the load is not continuous, is repetitive and has periods of no-load less than three times the cable's time constant, so that the cable has insufficient time to cool down between the applications of load, the cable's continuous rating may be increased by an intermittent factor, calculated in accordance with:

$$Intermittent\ factor = \sqrt{\frac{1 - e^{-\frac{t_p}{T}}}{1 - e^{-\frac{t_s}{T}}}}$$

where

t_p = the intermittent period, in minutes, i.e. the total period of load and no-load before the cycle is repeated

$T = 0,245d^{1,35}$ where d is the overall diameter of the cable, in mm

t_s = the service time of the load current in minutes

11.7.5 **Diversity.** Where cables are used to supply two or more final sub-circuits account may be taken of any diversity factors which may apply, see Pt 6, Ch 2, 5.6 Diversity factor.

11.8 Installation of electric cables

11.8.1 Electric and optical fibre cable runs are to be as far as practicable fixed in straight lines and in accessible positions.

11.8.2 Bends in fixed electric and optical fibre cable runs are to be in accordance with the cable manufacturer's recommendations. The minimum internal radius of bend for the installation of fixed electric cables is to be chosen according to the

construction and size of the cable and is not to be less than the values given in *Table 2.11.6 Minimum internal radii of bends in cables for fixed wiring*.

11.8.3 The installation of electric and optical fibre cables across expansion joints in any structure is to be avoided. Where this is not practicable, a loop of electric cable of length sufficient to accommodate the expansion of the joint is to be provided. For electric cables, the internal radius of the loop is to be at least 12 times the external diameter of the cable. For optical fibre cables, the internal radius of the loop is to meet the manufacturers' minimum recommendations.

11.8.4 Electric and optical fibre cables for essential and emergency services are to be arranged, so far as is practicable, to avoid galleys, machinery spaces and other enclosed spaces and high fire risk areas except as is necessary for the service being supplied. Such cables are also, so far as reasonably practicable, to be routed clear of bulkheads to preclude their being rendered unserviceable by heating of the bulkheads that may be caused by a fire in an adjacent space.

11.8.5 Electric cables having insulating materials with different maximum rated conductor temperatures are to be so installed that the maximum rated conductor temperature for normal operation of each cable is not exceeded.

11.8.6 Electric and optical fibre cables having a protective covering which may damage the covering of other cables are not to be bunched with those other cables.

Table 2.11.6 Minimum internal radii of bends in cables for fixed wiring

Cable construction		Overall diameter of cable	Minimum internal radius of bend (times overall diameter of cable)
Insulation	Outer covering		
Elastomeric 600/1000 V and below	Metal sheathed Armoured and braided	Any	6D
	Other finishes	≤ 25 mm > 25 mm	4D 6D
Mineral	Hard metal sheathed	Any	6D
Elastomeric above 600/1000 V – single core – multicore	Any	Any	12D
	Any	Any	9D

11.8.7 Cables having an exposed metallic screen, braid or armour are to be installed in such a manner that galvanic corrosion by contact with other metals is prevented. Sufficient measures are also to be taken to prevent damage to exposed galvanised coatings during installation.

11.8.8 Protection is to be provided for cable oversheaths in areas where cables are likely to be exposed to damaging substances under normal circumstances or areas where the spillage or release of harmful substances is likely.

11.8.9 Electric and optical fibre cables are to be as far as practicable installed remote from sources of heat. Where installation of cables near sources of heat cannot be avoided and where there is consequently a risk of damage to the cables by heat, suitable shields, insulation or other precautions are to be installed between the cables and the heat source. The free air circulation around the cables is not to be impaired.

11.8.10 Where electric and optical fibre cables are installed in bunches, provision is to be made to limit the propagation of fire. This requirement is considered satisfied when cables of the bunch have been tested in accordance with the requirements of IEC 60332-3-22: *Tests on electric and optical fibre cables under fire conditions – Part 3-22: Test for vertical flame spread of vertically-mounted bunched wires or cables – Category A*, and are installed in the same configuration(s) as are used for the test(s). If the cables are not so installed, information is to be submitted to demonstrate satisfactorily that suitable measures have been taken to ensure that an equivalent limit of fire propagation will be achieved for the configurations to be used. Particular attention is to be given to cables in:

- atria or equivalent spaces; and
- vertical runs in trunks and other restricted spaces.

In addition, cables that comply with the requirements of IEC 60332-3-22 are also required to meet the requirements of IEC 60332-1-2: *Tests on electric and optical fibre cables under fire conditions – Part 1-2: Test for vertical flame propagation for a single insulated wire or cable – Procedure for 1 kW pre-mixed flame*.

11.8.11 Electric and optical fibre cables are not to be coated or painted with materials which may adversely affect their sheath or their fire performance.

11.8.12 Where electric and optical fibre cables are installed in refrigerated spaces they are not to be covered with thermal insulation but may be placed directly on the face of the refrigeration chamber, provided that precautions are taken to prevent the electric cables being used as casual means of suspension.

11.8.13 All metal coverings of electric and optical fibre cables are to be earthed in accordance with *Pt 6, Ch 2, 1.12 Earthing of non-current carrying parts*.

11.8.14 High voltage cables may be installed as follows:

- (a) in the open, (e.g. on carrier plating), when they are to be provided with a continuous metallic sheath or armour which is effectively bonded to earth to reduce danger to personnel. The metallic sheath or armour may be omitted provided that the cable sheathing material has a longitudinal electric resistance high enough to prevent sheath currents which may be hazardous to personnel;
- (b) contained in earthed metallic protective casings when the cables may be as in *Pt 6, Ch 2, 11.8 Installation of electric cables 11.8.14* or the armour or metal sheath may be omitted. In the latter case care is to be taken to ensure that protective casings are electrically continuous and that short lengths of cable are not left unprotected.

11.8.15 High voltage electric cables are not to be run in the open through accommodation spaces.

11.8.16 High-voltage electric cables are to be segregated from electric cables operating at lower voltages.

11.8.17 Electric and optical fibre cables are to be, so far as reasonably practicable, installed remote from sources of mechanical damage. Where necessary the cables are to be protected in accordance with the requirements of *Pt 6, Ch 2, 11.9 Mechanical protection of cables*.

11.8.18 Electric and optical fibre cables with the exception of those for portable appliances and those installed in protective casings are to be fixed securely in accordance with the requirements of *Pt 6, Ch 2, 11.10 Cable support systems*.

11.8.19 Electric and optical fibre cables serving any essential services and any glands through which they pass must be able to withstand flooding for a period of 36 hours, based on the water pressure that may occur at the location.

11.8.20 Where electric and optical fibre cables penetrate bulkheads and decks the requirements of *Pt 6, Ch 2, 11.11 Penetration of bulkheads and decks by cables* are to be complied with.

11.8.21 Where electric and optical fibre cables are installed in protective casings the requirements of *Pt 6, Ch 2, 11.12 Installation of electric and optical fibre cables in protective casings* are to be complied with.

11.8.22 a.c. wiring is to be carried out using multicore cables wherever reasonably practicable. Where it is necessary to install single core electric cables for alternating current circuits in excess of 20 Amps the requirements of *Pt 6, Ch 2, 11.14 Single-core electric cables for alternating current* are to be complied with, see also *Pt 6, Ch 2, 11.5 Construction 11.5.8*.

11.9 Mechanical protection of cables

11.9.1 Electric cables exposed to risk of mechanical damage are to be protected by suitable protective casings unless the protective covering (e.g. armour or sheath) is sufficient to withstand the possible cause of damage.

11.9.2 Electric cables installed in spaces where there is exceptional risk of mechanical damage such as holds, storage spaces, cargo spaces, etc. are to be suitably protected by metallic protective casings, even when armoured, unless the ship's structure affords adequate protection.

11.9.3 Metal protective casings are to be efficiently protected against corrosion, and effectively earthed in accordance with *Pt 6, Ch 2, 1.12 Earthing of non-current carrying parts*.

11.10 Cable support systems

11.10.1 Electric cables are to be effectively supported and secured, without being damaged, to the ship's structure, either indirectly by a cable support system, or directly by means of clips, saddles or straps to bulkheads etc. see *Pt 6, Ch 2, 11.8 Installation of electric cables 11.8.4*.

11.10.2 Cable support systems, which may be in the form of trays or plates, separate support brackets, hangers or ladder racks, together with their fixings and accessories, are to be robust and are to be of corrosion-resistant material or suitably corrosion inhibited before erection. The cable support system is to be effectively secured to the ship's structure, the spacing of the

fixings taking account of the probability of vibration and any heavy external forces, e.g. where located in areas subject to impact by sea-water.

11.10.3 The distances between the points at which the cable is supported (e.g. distances between ladder rungs, support brackets, hangers, etc.) are to be chosen according to the construction of cable (i.e. size and rigidity) and the probability of vibration and are to be generally in accordance with those given in *Table 2.11.7 Maximum spacing for supports or fixings for securing cables*.

Table 2.11.7 Maximum spacing for supports or fixings for securing cables

External diameter of cable		Non-armoured cables	Armoured cables
exceeding	not exceeding		
mm	mm	mm	mm
-	8	200	250
8	13	250	300
13	20	300	350
20	30	350	400
30	-	400	450

11.10.4 Where the cables are laid on top of their support system, the spacings of fixings may be increased beyond those given in *Table 2.11.7 Maximum spacing for supports or fixings for securing cables*, but should take account of the probability of movement and vibration and in general is not to exceed 900 mm. This relaxation is not to be applied where cables can be subjected to heavy external forces, e.g. where they are run on, or above, open deck or in areas subject to impact by sea-water.

11.10.5 Single core electric cables are to be firmly fixed, using supports of strength adequate to withstand forces corresponding to the values of the peak prospective short-circuit current.

11.11 Penetration of bulkheads and decks by cables

11.11.1 Where electric and optical fibre cables pass through watertight, fire insulated or gastight bulkheads or decks separating hazardous zones or spaces from non-hazardous zones or spaces, the arrangements are to be such as to ensure the integrity of the bulkhead or deck is not impaired. The arrangements chosen are to ensure that the cables are not adversely affected.

11.11.2 Where cables pass through non-watertight bulkheads or structural steel, the holes are to be bushed with suitable material. If the steel is at least 6 mm thick, adequately rounded edges may be accepted as the equivalent of bushing.

11.11.3 Electric and optical fibre cables passing through decks are to be protected by deck tubes or ducts.

11.11.4 Where cables pass through thermal insulation they are to do so at right angles, in tubes sealed at both ends.

11.12 Installation of electric and optical fibre cables in protective casings

11.12.1 Protective casings are to be mechanically continuous across joints and effectively supported and secured to prevent damage to the electric or optical fibre cables.

11.12.2 Protective casings are to be suitably smooth on the interior and have their ends shaped or bushed in such a manner as not to damage the cables.

11.12.3 The internal radius of bends of protective casings are to be not less than that required for the largest cable installed therein, see *Pt 6, Ch 2, 11.8 Installation of electric cables 11.8.2*.

11.12.4 The space factor (ratio of the sum of the cross sectional areas corresponding to the external diameters of the cables to the internal cross-sectional area of the protective casings) is not to exceed 0,4.

11.12.5 Where necessary, ventilation openings are to be provided at the highest and lowest points of protective casings to permit air circulation and to prevent accumulation of water.

11.12.6 Expansion joints are to be provided in protective casings where necessary.

11.12.7 Protective casings containing high voltage electric cables are not to contain other electric or optical fibre cables and are to be clearly identified, defining their function and voltage.

11.13 Non-metallic cable support systems, protective casings and fixings

11.13.1 Where it is proposed to use non-metallic cable support systems, protective casings or fixings, the additional requirements of this sub-Section apply. For high voltage installations, metallic protective casings are required where *Pt 6, Ch 2, 11.8 Installation of electric cables 11.8.14* applies.

11.13.2 Non-metallic cable support systems and protective casings are to be installed in accordance with the manufacturer's recommendations. The support systems and protective casings are to have been tested in accordance with an acceptable test procedure for:

- (a) ambient operating temperatures;
- (b) safe working load;
- (c) impact resistance;
- (d) flame retardancy;
- (e) smoke and toxicity; and
- (f) use in explosive gas atmospheres or in the presence of combustible dusts, electrical conductivity;

with satisfactory results.

11.13.3 Non-metallic cable support systems, protective casings and fixings installed on the open deck are to be protected from degradation caused by exposure to solar radiation.

11.13.4 Where the cable support system, protective casing or fixings are manufactured from a material other than metal, suitable supplementary metallic fixings or straps spaced at regular distances are to be provided such that, in the event of a fire or failure, the cable support system, protective casing and the affixed cables are prevented from falling and causing an injury to personnel and/or an obstruction to any escape route. Alternatively, the cables may be routed away from such areas.

11.13.5 The load on non-metallic cable support systems or protective casings is not to exceed the tested safe working load.

11.13.6 When a cable support system or protective casing is secured by means of clips or straps manufactured from a material other than metal the fixings are to be supplemented by suitable metal clips or straps spaced at regular distances each not exceeding 2 m and, for non-metallic cable support systems or protective casings, that used during safe working load testing.

11.13.7 Non-metallic fixings are to be flame retardant in accordance with the requirements of IEC 60092-101: *Electrical installations in ships – Part 101: Definitions and general requirements*, or an alternative relevant National or International Standard.

11.14 Single-core electric cables for alternating current

11.14.1 When installed in protective casings, electric cables belonging to the same circuit are to be installed in the same casing, unless the casing is of non-magnetic material.

11.14.2 Cable clips are to include electric cables of all phases of a circuit unless the clips are of non-magnetic material.

11.14.3 Single-core cables of the same circuit are to be in contact with one another, as far as possible. In any event the distance between adjacent electric cables is not to be greater than one cable diameter.

11.14.4 If single-core cables of current rating greater than 250 A are installed near a steel bulkhead, the clearance between the cables and the bulkhead is to be at least 50 mm unless the cables belonging to the same a.c. circuit are installed in trefoil formation.

11.14.5 Magnetic material is not to be used between single core cables of a group. Where cables pass through steel plates, all the conductors of the same circuit are to pass through a plate or gland, so made that there is no magnetic material between the cables, and the clearance between the cables and the magnetic material is not to be less than 75 mm, unless the cables belonging to the same a.c. circuit are installed in trefoil formation.

11.14.6 Electric cables are to be installed such that the induced voltages, and any circulating currents, in the sheath or armour are limited to safe values.

11.15 Electric cable ends

11.15.1 Where screw-clamp or spring-clamp type terminations are used in electrical apparatus for external cable connections, see *Pt 6, Ch 2, 1.11 Location and construction 1.11.7*, cable conductors of the solid or stranded type may be inserted directly into

the terminals. Where flexible conductors are used, a suitable termination is to be fitted to the cable conductor to prevent 'whiskering' of the strands.

11.15.2 If compression type conductor terminations are used on the cable ends, they are to be of a size to match the conductor and to be made with a compression type tool with the dies selected to suit the termination and conductor sizes and having a ratchet action to ensure completion of the compression action.

11.15.3 Soldered sockets may be used in conjunction with non corrosive fluxes provided that the maximum conductor temperature at the joint, under short-circuit conditions, does not exceed 160°C.

11.15.4 High voltage cables of the radial field type (i.e. having a conducting layer to control the electric field within the insulation) are to have terminations which provide electrical stress control.

11.15.5 Electric cables having hygroscopic insulation (e.g. mineral insulated) are to have their ends sealed against ingress of moisture.

11.15.6 Cable terminations are to be of such a design and dimensions that the maximum current likely to flow through them will not result in degradation of the contacts or damage to insulation as the result of overheating.

11.15.7 The fixing of conductors in terminals at joints and at tappings is to be capable of withstanding the thermal and mechanical effects of short-circuit currents.

11.16 Joints and branch circuits in cable systems

11.16.1 If a joint is necessary it is to be carried out so that all conductors or fibres are adequately secured, insulated and protected from atmospheric action. The flame retardant properties of the cable are to be retained, the continuity of metallic sheath, braid or armour is to be maintained and the current carrying capacity or transmission of data through the cable is not to be impaired.

11.16.2 Tappings (branch circuits) are to be made in suitable boxes of such a design that the conductors and fibres remain suitably insulated, protected from atmospheric action and fitted with terminals or busbars of dimensions appropriate to the current rating.

11.16.3 Tappings and splices of optical fibre cables are to be made in accordance with the manufacturers' recommendations and to be provided with appropriate fittings. In addition they are to be located within suitably designed enclosures to ensure that the protection of the optical fibres is maintained.

11.16.4 Cables of a fire resistant type, see *Pt 6, Ch 2, 11.5 Construction 11.5.3* are to be installed so that they are continuous throughout their length without any joints or tappings.

11.17 Busbar trunking systems (bustrunks)

11.17.1 Where busbar trunking systems are used in place of electric cables, they are to comply with the requirements of *Pt 6, Ch 2, 11.17 Busbar trunking systems (bustrunks) 11.17.2 to Pt 6, Ch 2, 11.17 Busbar trunking systems (bustrunks) 11.17.6*, in addition to the applicable requirements in *Pt 6, Ch 2, 7 Switchgear and controlgear assemblies*.

11.17.2 The busbar trunking, or enclosure system, is to have a minimum ingress protection of IP54, according to IEC60529: *Degrees of protection provided by enclosures* (IP Code).

11.17.3 The internal and external arrangements of the busbar trunking, or enclosure system, are to ensure that the fire and/or watertight integrity of any structure through which it passes is not impaired.

11.17.4 Where the busbar trunking system is employed for circuits on and below the bulkhead deck, arrangements are to be made to ensure that circuits on other decks are not affected in the event of partial flooding under the normal angles of inclination given in *Pt 6, Ch 2, 1.10 Inclination of ship* for essential electrical equipment.

11.17.5 Supports and accessories are to be robust and are to be of corrosion-resistant material or suitably corrosion inhibited before erection. The support system is to effectively secure the busbar trunking system to the ship's structure.

11.17.6 When accessories are fixed to the busbar system by means of clips or straps manufactured from a material other than metal, the fixings are to be supplemented by suitable metal clips or straps, such that, in the event of a fire or failure, the accessories are prevented from falling and causing injury to personnel and/or an obstruction to any escape route. Alternatively, the busbar system may be routed away from such areas.

■ Section 12 Batteries

12.1 General

12.1.1 The requirements of this Section apply to permanently installed secondary batteries of the vented and valve - regulated sealed type.

12.1.2 A vented battery is one in which the cells have a cover provided with an opening through which the products of electrolysis and evaporation are allowed to escape freely from the cells to the atmosphere.

12.1.3 A valve-regulated sealed battery is one in which the cells are closed but have an arrangement (valve) which allows the escape of gas if the internal pressure exceeds a predetermined value. The electrolyte cannot normally be replaced.

12.2 Construction

12.2.1 Batteries are to be constructed so as to prevent spilling of the electrolyte due to motion and to minimise the emission of electrolyte spray.

12.3 Location

12.3.1 Vented batteries connected to a charging device with a power output of more than 2 kW, calculated from the maximum obtainable charging current and the nominal voltage of the battery, are to be housed in an adequately ventilated compartment assigned to batteries only, or in an adequately ventilated suitable box on open deck.

12.3.2 Vented batteries connected to a charging device with a power output within the range 0,2 kW to 2 kW, calculated from the maximum obtainable charging current and the nominal voltage of the battery, are to be installed in accordance with *Pt 6, Ch 2, 12.3 Location 12.3.1*, or may be installed within a well ventilated machinery or similar space.

12.3.3 Vented batteries connected to a charging device with a power output of less than 0,2 kW, calculated from the maximum obtainable charging current and the nominal voltage of the battery, may be installed in an open position or in a battery box in any suitable space.

12.3.4 Where more than one charging device is installed for any battery or group of batteries in one location, the total power output is to be used to determine the installation requirements of *Pt 6, Ch 2, 12.3 Location 12.3.1*, *Pt 6, Ch 2, 12.3 Location 12.3.2* or *Pt 6, Ch 2, 12.3 Location 12.3.3*.

12.3.5 Valve-regulated sealed batteries may be located in compartments with standard marine or industrial electrical equipment provided that the ventilation requirements of *Pt 6, Ch 2, 12.5 Ventilation 12.5.11* and the charging requirements of *Pt 6, Ch 2, 12.6 Charging facilities 12.6.4* and *Pt 6, Ch 2, 12.6 Charging facilities 12.6.5* are complied with. Equipment that may produce arcs, sparks or high temperatures in normal operation is not to be in close proximity to battery vent plugs or pressure relief valve outlets.

12.3.6 Where lead-acid and nickel-cadmium batteries are installed in the same compartment precautions are to be taken, such as the provision of screens, to prevent possible contamination of electrolytes.

12.3.7 Where batteries may be exposed to the risk of mechanical damage, or falling objects, they are to be suitably protected.

12.3.8 Batteries installed in crew and passenger cabins, together with their associated corridors, are to be of the hermetically sealed type.

12.3.9 A permanent notice prohibiting smoking and the use of naked lights or equipment capable of creating a source of ignition is to be prominently displayed adjacent to the entrances of all compartments containing batteries.

12.3.10 Only electrical equipment necessary for operational reasons and for the provision of lighting is to be installed in compartments provided in compliance with *Pt 6, Ch 2, 12.3 Location 12.3.1*, the compartment ventilation exhaust ducts and zones within a 1,5 m radius of the ventilation outlet(s). Such electrical equipment is to be certified for group IIC gases and temperature Class T1 in accordance with the applicable parts of IEC 60079: *Explosive atmospheres*, or an acceptable and relevant National Standard.

12.3.11 A permanent notice is to be prominently displayed adjacent to battery installations advising personnel that replacement batteries are to be of an equivalent performance type. For valve-regulated sealed batteries, the notice is to advise of the requirement for replacement batteries to be suitable with respect to products of electrolysis and evaporation being allowed to escape from cells to the atmosphere, see also *Pt 6, Ch 2, 1.5 Additions or alterations 1.5.3*.

12.4 Installation

12.4.1 Batteries are to be arranged such that each cell or crate of cells is accessible from the top and at least one side and it is to be ensured that they are suitably secured to move with the ship's motion.

12.4.2 The materials used in the construction of a battery rack or stand are to be resistant to the battery electrolyte or suitably protected by paint or a coating.

12.4.3 Measures are to be taken to minimise the effect of any electrolyte spillage and leakage, for example the use of rubber capping around the top of the cells and the provision of a tray of electrolyte-resistant material below the cells, unless the deck is suitably protected with paint or a coating.

12.4.4 The interiors of all compartments for batteries, including crates, trays, boxes, shelves and other structural parts therein, are to be of an electrolyte-resistant material or suitably protected, for example with paint or a coating.

12.5 Ventilation

12.5.1 Battery compartments and boxes are to be ventilated to avoid accumulation of dangerous concentrations of flammable gas.

12.5.2 Where a battery compartment ventilator is required to be fitted with a closing device in accordance with *Pt 3, Ch 12, 2.3 Closing appliances 2.3.9*, a warning notice clearly stating the purpose of the closing device, for example:

'This closing device is to be kept open and only closed in the event of a fire or flooding – Explosive gas atmosphere'

is to be provided at the closing device to mitigate the possibility of inadvertent closing of the ventilator. Furthermore, means to lock the battery compartment ventilators in the open position are to be provided.

12.5.3 Ducted natural ventilation may be employed for battery installations connected to a charging device with a power output of 2 kW or less, provided the exhaust duct can be run directly from the top of the compartment or box to the open air above, with no part of the duct more than 45° from the vertical. A suitable opening is also to be provided below the level of the top of the batteries, so as to ensure a free ventilation air flow. The ventilation duct is to have an area not less than 50 cm² for every 1 m³ of battery compartment or box volume.

12.5.4 Where natural ventilation is impracticable or insufficient, mechanical ventilation is to be provided, with the air inlet located near the floor and the exhaust at the top of the compartment.

12.5.5 Mechanical exhaust ventilation complying with *Pt 6, Ch 2, 12.5 Ventilation 12.5.9* is to be provided for battery installations connected to a charging device with a total maximum power output of more than 2 kW. Also, to minimise the possibility of oxygen enrichment, compartments and spaces containing batteries with boost charging facilities are to be provided with mechanical exhaust ventilation irrespective of the charging device power output.

12.5.6 The ventilation system for battery compartments and boxes, other than boxes located on open deck or in spaces to which *Pt 6, Ch 2, 12.3 Location 12.3.2, Pt 6, Ch 2, 12.3 Location 12.3.3* and *Pt 6, Ch 2, 12.3 Location 12.3.5* refer, is to be separate from other ventilation systems. The exhaust ducting is to be led to a location in the open air, where any gases can be safely diluted, away from possible sources of ignition and openings into spaces where gases may accumulate.

12.5.7 Fan motors associated with exhaust ducts from battery compartments are to be placed external to the ducts and the compartments.

12.5.8 Ventilating fans for battery compartments are to be so constructed and be of material such as to minimise risk of sparking in the event of the impeller touching the casing. Non-metallic-impellers are to be of an anti-static material.

12.5.9 Battery boxes are to be provided with sufficient ventilation openings located so as to avoid accumulation of flammable gas whilst preventing the entrance of rain or spray.

12.5.10 The ventilation arrangements for all installations of vented type batteries are to be such that the quantity of air expelled is at least equal to:

$$Q = 110In$$

where

n = number of cells in series

where

I = maximum current delivered by the charging equipment during gas formation, but not less than 25 per cent of the maximum obtainable charging current in amperes

Q = quantity of air expelled in litres/hr.

12.5.11 The ventilation rate for compartments containing valve-regulated sealed batteries may be reduced to 25 per cent of that given in *Pt 6, Ch 2, 12.5 Ventilation 12.5.10*.

12.6 Charging facilities

12.6.1 Charging facilities are to be provided for all secondary batteries such that they may be completely charged from the completely discharged state in a reasonable time having regard to the service requirements.

12.6.2 Suitable means including an ammeter and a voltmeter, are to be provided for controlling and monitoring charging of batteries, and to protect them against discharge into the charging circuits.

12.6.3 For floating circuits or any other conditions where the load is connected to the battery whilst it is on charge, the maximum battery voltage is not to exceed the safe value for any connected apparatus.

12.6.4 Where valve-regulated sealed batteries are installed, the charging facilities are to incorporate independent means such as overvoltage protection to prevent gas evolution in excess of the manufacturer's design quantity.

12.6.5 Boost charge facilities, where provided, are to be arranged such that they are automatically disconnected should the battery compartment ventilation system fail.

12.7 Recording of batteries for emergency and essential services

12.7.1 A schedule of batteries fitted for use for essential and emergency services is to be compiled and maintained.

12.7.2 Procedures are to be put in place and documented to ensure that, where batteries are replaced, they are of an equivalent performance type, *see also Pt 6, Ch 2, 1.5 Additions or alterations 1.5.3*.

12.7.3 When additions or alterations are proposed to the existing batteries for essential and emergency services, the schedule and replacement procedure documentation are to be updated to reflect the proposed installation and submitted in accordance with *Pt 6, Ch 2, 1.5 Additions or alterations 1.5.2*.

12.7.4 The schedule and replacement procedure documentation are to be made available to the LR Surveyor on request.

■ **Section 13 Equipment - Heating, lighting and accessories**

13.1 Heating and cooking equipment

13.1.1 The construction of heaters is to give a degree of protection according to IEC 60529: *Degrees of protection provided by enclosures (IP Code)*, or an acceptable and relevant National Standard, suitable for the intended location.

13.1.2 Heating elements are to be suitably guarded.

13.1.3 Heating and cooking equipment is to be installed such that adjacent bulkheads and decks are not subjected to excessive heating.

13.2 Lighting - General

13.2.1 Lampholders are to be constructed of flame retarding non-hygroscopic materials.

13.2.2 Lighting fittings are to be so arranged as to prevent temperature rises which overheat or damage surrounding materials. They must not impair the integrity of fire divisions.

13.3 Incandescent lighting

13.3.1 Tungsten filament lamps and lampholders are to be in accordance with *Table 2.13.1 Lamps and lampholders*.

Table 2.13.1 Lamps and lampholders

Designation	Maximum lamp rating		Maximum lampholder current, A
	Voltage, V	Power, W	
Screw cap lamps			
E40	250	3000	16
E27	250	200	4
E14	250	15	2
E10	24	-	2
Bayonet cap lamps			
B22	250	200	4
B15d	250	15	2
B15s	55	15	2
Tubular fluorescent lamps			
G13	250	115	-
G5	250	80	-
Note Other lamp types are to be in accordance with IEC 60092-306: <i>Electrical installations in ships - Part 306: Equipment - Luminaires and lighting accessories</i> .			

13.3.2 Lampholders of type E40 are to be provided with a means of locking the lamp in the lampholder.

13.4 Fluorescent lighting

13.4.1 Fluorescent lamps and lampholders are to be in accordance with *Table 2.13.1 Lamps and lampholders*.

13.4.2 Fittings, reactors, capacitors and other auxiliaries are not to be mounted on surfaces which are subject to high temperatures. If mounted separately they are additionally to be enclosed in an earthed conductive casing.

13.4.3 Where capacitors of 0,5 microfarads and above are installed, means are to be provided to promptly discharge the capacitors on disconnection of the supply.

13.5 Discharge lighting

13.5.1 Discharge lamps operating in excess of 250 V are only acceptable as fixed fittings. Warning notices calling attention to the voltage are to be permanently displayed at points of access to the lamps and where otherwise necessary.

13.6 Socket outlets and plugs

13.6.1 The temperature rise on the live parts of socket outlet and plugs is not to exceed 30°C. Socket outlets and plugs are to be so constructed that they cannot be readily short-circuited whether the plug is in or out, and so that a pin of the plug cannot be made to earth either pole of the socket outlet.

13.6.2 All socket outlets of current rating in excess of 16 A are to be provided with a switch, and be interlocked such that the plug cannot be inserted or withdrawn when the switch is in the 'on' position.

13.6.3 Where it is necessary to earth the non-current carrying parts of portable or transportable equipment, an effective means of earthing is to be provided at the socket outlet.

13.6.4 On weather decks, galleys, laundries, machinery spaces and all wet situations socket outlets and plugs are to be effectively shielded against rain and spray and are to be provided with means of maintaining this quality after removal of the plug.

13.7 Enclosures

13.7.1 Enclosures for the containing and mounting of electrical accessories are to be of metal, effectively protected against corrosion, or of flame retardant insulating materials.

■ Section 14

Electrical equipment for use in explosive gas atmospheres or in the presence of combustible dusts

14.1 General

14.1.1 The installation of electrical equipment in spaces and locations in which flammable mixtures are liable to collect, e.g. areas containing flammable gas or vapour and/or combustible dust, is to be minimised as far as is consistent with operational necessity and the provision of lighting, monitoring, alarm or control facilities enhancing the overall safety of the ship.

14.1.2 In order to eliminate potential sources of ignition from spaces and locations in which flammable mixtures are liable to collect, in accordance with SOLAS - *International Convention for the Safety of Life at Sea* as amended, Chapter II-1, *Regulation 45 - Precautions against shock, fire and other hazards of electrical origin (Paragraphs 10 and 11 of this regulation apply to ships constructed on or after 1 January 2007)*, such dangerous or hazardous areas are to be identified and electrical equipment within these areas is to be selected and installed in accordance with the requirements of this Section.

14.1.3 Equipment that is to be installed in an area where both explosive gases and combustible dusts can be present is to be selected in accordance with both *Pt 6, Ch 2, 14.2 Selection of equipment for use in explosive gas atmospheres* and *Pt 6, Ch 2, 14.3 Selection of equipment for use in the presence of combustible dusts*.

14.1.4 For permanent secondary battery installations, see *Pt 6, Ch 2, 12 Batteries*.

14.2 Selection of equipment for use in explosive gas atmospheres

14.2.1 When equipment is to be installed in areas where an explosive gas atmosphere may be present, it is generally to be of a type providing protection against ignition of the gases encountered and compliant with the relevant Parts of IEC 60079: *Explosive atmospheres*, or an acceptable and relevant National Standard, unless permitted otherwise by *Pt 6, Ch 2, 14.2 Selection of equipment for use in explosive gas atmospheres 14.2.4*, *Pt 6, Ch 2, 14.2 Selection of equipment for use in explosive gas atmospheres 14.2.5* or *Pt 6, Ch 2, 14.2 Selection of equipment for use in explosive gas atmospheres 14.2.6*.

14.2.2 The equipment protection type permitted depends on the hazardous zone where the equipment is to be located, as defined in *Pt 6, Ch 2, 14.5 Hazardous zones and spaces*. For certain locations on the ship other requirements may limit installations to specific equipment types and/or particular applications.

14.2.3 Equipment for **zone 0** or **zone 1**, with the exception of simple apparatus as defined in *Pt 6, Ch 2, 14.2 Selection of equipment for use in explosive gas atmospheres 14.2.4* or *Pt 6, Ch 2, 14.2 Selection of equipment for use in explosive gas atmospheres 14.2.5*, is to be certified or approved by a National or other appropriate authority. Equipment without independent certification or approval may be considered for installation in **zone 2**.

14.2.4 In **zone 0**, the following may be considered:

- (a) intrinsically safe, category 'a' (Ex 'ia'); or
- (b) simple electrical apparatus and components (for example thermocouples, photocells, strain gauges, junction boxes, switching devices), included in intrinsically safe circuits of category 'ia', not capable of storing or generating electrical power or energy in excess of the limits given in IEC 60079-14: *Explosive atmospheres – Part 14: Electrical installations design, selection and erection*.

14.2.5 In **zone 1**, the following may be considered:

- (a) apparatus permitted within **zone 0**;
- (b) intrinsically safe, category 'b' (Ex 'ib');
- (c) simple apparatus as defined above, included in intrinsically safe circuits of category 'ib';
- (d) increased safety (Ex 'e');
- (e) flameproof (Ex 'd');

- (f) pressurised enclosure (Ex 'p');
- (g) powder filled (Ex 'q'); or
- (h) encapsulated (Ex 'm').

14.2.6 In **zone 2**, the following may be considered:

- (a) apparatus permitted within **zone 0** or **zone 1**;
- (b) type of protection 'n' or 'N';
- (c) equipment such as control panels, protected by purging and pressurisation and capable of being verified by inspection as meeting the requirements of IEC 60079-2: *Explosive atmospheres – Part 2: Equipment protection by pressurized enclosures "p"*; or
- (d) radio aerials having robust construction, meeting the relevant requirements of IEC 60079-15: *Explosive atmospheres – Part 15: Equipment protection by type of protection "n"*. Additionally, in the case of transmitter aerials, it is to be shown, by detailed study or measurement, or by limiting the peak radiated power and field strength to 1 W and 30 V/m, respectively, that they present negligible risk of inducing incendive sparking in adjacent structures or equipment.

14.2.7 Apparatus having type of protection 'ia', 'ib', or 'd', is to be of a Group (IIA, IIB or IIC) meeting or exceeding that required for safe operation in the presence of any gas or vapour that can be present, or is to be certified specifically for such gases or vapours.

14.2.8 All apparatus is to be of a temperature classification (T1 to T6) that confirms, or is to be assessed so as to confirm, that its maximum surface temperature will not reach the ignition temperature of any gas or vapour, or mixture of gases or vapours, which can be present. The surface temperature considered may be that of an internal or external part, according to the type of protection of the apparatus.

14.2.9 Consideration may also be given to other types of protection, selected in accordance with the requirements of IEC 60079-14: *Explosive atmospheres – Part 14: Electrical installations design, selection and erection* or arrangements complying with IEC 60092-502: *Electrical installations in ships – Part 502: Tankers – Special features, see also Pt 6, Ch 2, 14.10 Requirements for tankers intended for the carriage in bulk of oil cargoes having a flash point not exceeding 60°C (closed-cup test) to Pt 6, Ch 2, 14.12 Requirements for ships intended for the carriage in bulk of other flammable liquid cargoes.*

14.3 Selection of equipment for use in the presence of combustible dusts

14.3.1 Where apparatus is to be installed in **hazardous areas**, as defined by *Pt 6, Ch 2, 14.5 Hazardous zones and spaces 14.5.3*, associated with the presence of combustible dusts, it is, when practicable, to be of a type certified or approved by a National or other appropriate authority for the dusts and, additionally, any explosive gases encountered.

14.3.2 Electrical equipment for use in such **hazardous areas** is to be so designed and installed as to minimise the accumulation of dust which may interfere with the safe dissipation of heat from the enclosure.

14.3.3 Where apparatus is to be installed in **extended hazardous areas**, as defined by *Pt 6, Ch 2, 14.5 Hazardous zones and spaces 14.5.3*, associated with the presence of combustible dust, the following may be considered:

- (a) apparatus permitted within a hazardous area associated with the combustible dust(s) that can be present;
- (b) apparatus having degree of protection IP5X, or better, and having a surface temperature under normal operating conditions not exceeding the auto-ignition temperature of the dust(s) that can be present; and
- (c) apparatus of a type which ensures absence of sparks or arcs and hot spots during normal operation.

14.3.4 Where equipment certified for combustible dusts is not available, consideration will be given to the use of apparatus complying as a minimum, with the following requirements provided no explosive gases will be present:

- (a) the enclosure is to be at least dust protected (IP5X) having, when type tested, an ingress of fine dust within the enclosure not exceeding 10 g per m³ of free air space, and
- (b) the surface temperature of the apparatus, under the most onerous combination of normal operating conditions, but in the absence of a dust layer, is not to exceed two-thirds of the minimum ignition temperature in degrees Celsius of the dust/air mixture(s) that can be present, or
- (c) the equipment is to be certified intrinsically safe having a temperature classification ensuring compliance with *Pt 6, Ch 2, 14.2 Selection of equipment for use in explosive gas atmospheres 14.2.5*, or
- (d) pressurised and operated in accordance with procedures ensuring, prior to its re-energisation, the absence of dust within the enclosure following loss of pressurisation and consequent shutdown, and having surface temperature complying with (b), or

(e) simple apparatus included in intrinsically safe circuits or radio aerials, complying with *Pt 6, Ch 2, 14.2 Selection of equipment for use in explosive gas atmospheres 14.2.5* or *Pt 6, Ch 2, 14.2 Selection of equipment for use in explosive gas atmospheres 14.2.6* respectively.

14.3.5 Consideration may also be given to arrangements complying with IEC 60092-506: *Electrical Installation in ships – Part 506: Special features – Ships carrying specific dangerous goods and materials hazardous only in bulk*.

14.4 Installation of electrical equipment

14.4.1 The method of installation and application of electrical equipment suitable for use in explosive gas atmospheres or in the presence of combustible dusts is to be in accordance with IEC 60079-14: *Explosive atmospheres – Part 14: Electrical installations design, selection and erection*, or the national code of practice relevant to the standard with which the equipment complies. The ambient temperature range for which the apparatus is certified is to be taken to be -20°C to 40°C , unless otherwise stated, and account is to be taken of this when assessing the suitability of the equipment for the auto-ignition temperature of the gases and dusts encountered. Any special requirements laid down by the equipment certification documentation are also to be observed.

14.4.2 All switches and protective devices from which equipment located in hazardous zones or spaces is supplied are to interrupt all poles or phases and, where practicable are to be located in a non-hazardous zone or space. Such equipment, switches and protective devices are to be suitably labelled for identification purposes.

14.5 Hazardous zones and spaces

14.5.1 Hazardous zones or spaces and sources of hazard for ships intended for the carriage in bulk of oil, liquefied gases and other hazardous substances, the requirements for ships carrying vehicles with fuel in their tanks and the requirements for ships with spaces for storing paint, are defined (either directly, or by reference to other documents) in *Pt 6, Ch 2, 14.10 Requirements for tankers intended for the carriage in bulk of oil cargoes having a flash point not exceeding 60°C (closed-cup test)* to *Pt 6, Ch 2, 14.15 Requirements for ships with spaces for storing paint*.

14.5.2 Hazardous areas associated with flammable liquids or gases are classified into zones based upon the frequency of the occurrence and duration of an explosive gas atmosphere, as follows:

- **zone 0:** place in which an explosive atmosphere consisting of a mixture with air of flammable substances in the form of gas, vapour or mist is present continuously or for long periods or frequently
- **zone 1:** place in which an explosive atmosphere consisting of a mixture with air of flammable substances in the form of gas, vapour or mist is likely to occur in normal operation occasionally
- **zone 2:** place in which an explosive atmosphere consisting of a mixture with air of flammable substances in the form of gas, vapour or mist is not likely to occur in normal operation but, if it does occur, will persist for a short period only.

See IEC 60079-10-1: *Explosive atmospheres – Part 10-1: Classification of areas – Explosive gas atmospheres*.

14.5.3 Hazardous areas associated with solid substances or packaged liquids to which *Pt 6, Ch 2, 14.14 Special requirements for ships intended for the carriage of dangerous goods and materials hazardous only in bulk* applies are classified into zones based upon the frequency of the occurrence and duration of an explosive atmosphere due to the presence of gas and/or dust, as follows:

- **hazardous area:** area in which an explosive atmosphere is likely to occur in normal operation (comparable with **zone 1**)
- **extended hazardous area:** area in which an explosive atmosphere is not likely to occur in normal operation and, if it does occur, is likely to do so only infrequently and will exist for a short period only (comparable with **zone 2**).

See IEC 60079-10-2: *Explosive atmospheres – Part 10-2: Classification of areas – Combustible dust atmospheres*, or IEC 60092-506: *Electrical Installation in ships – Part 506: Special features – Ships carrying specific dangerous goods and materials hazardous only in bulk*. An explosive atmosphere may exist due to gas and/or dust.

14.5.4 The following principles are to apply in general, and where any specific arrangement does not fall into any of the categories covered by *Pt 6, Ch 2, 14.10 Requirements for tankers intended for the carriage in bulk of oil cargoes having a flash point not exceeding 60°C (closed-cup test)* to *Pt 6, Ch 2, 14.15 Requirements for ships with spaces for storing paint*.

14.5.5 A hazardous zone or space may arise from the presence of any of the following:

(a) spaces or tanks containing either:

- (i) flammable liquid having a flashpoint (closed-cup test) not exceeding 60°C ;
- (ii) flammable liquid having a flashpoint exceeding 60°C , heated or raised by ambient conditions to a temperature within 15°C of its flashpoint; or

- (iii) flammable gas;
- (b) piping systems or equipment containing fluid defined by (a) and having flanged joints or glands or other openings through which leakage of fluid may occur under normal operating conditions;
- (c) spaces containing solids, such as coal or grain, liable to release flammable gas and/or combustible dust;
- (d) spaces containing dangerous goods in packaged form, of the following Classes as defined in the IMDG Code: 1 (with the exception of goods in division 1.4, compatibility group S), 2.1 (inclusive of applicable gas bottles for on board use), 3, 6.1 and 8;
- (e) piping systems or equipment associated with processes (such as electrochlorination) generating flammable gas as a by-product and having openings from which the gas may escape under normal operating conditions; or
- (f) piping systems or equivalent containing flammable liquids not defined by *Pt 6, Ch 2, 14.5 Hazardous zones and spaces 14.5.5*, having flanged joints, glands or other openings through which leakage of fluid in the form of a mist or fine spray may occur under normal operating conditions.

14.5.6 The following zones or spaces are regarded as hazardous, **zone 0**:

- (a) the interiors of those spaces, tanks, piping systems and equipment defined by *Pt 6, Ch 2, 14.5 Hazardous zones and spaces 14.5.5* and *Pt 6, Ch 2, 14.5 Hazardous zones and spaces 14.5.5*; and
- (b) enclosed, unventilated spaces containing pipework or equipment defined by *Pt 6, Ch 2, 14.5 Hazardous zones and spaces 14.5.5* and *Pt 6, Ch 2, 14.5 Hazardous zones and spaces 14.5.5*.

14.5.7 The following zones or spaces are regarded as hazardous, **zone 1**:

- (a) unventilated spaces separated by a single bulkhead or deck from a cargo defined by *Pt 6, Ch 2, 14.5 Hazardous zones and spaces 14.5.5*;
- (b) ventilated spaces containing pipework or equipment defined by *Pt 6, Ch 2, 14.5 Hazardous zones and spaces 14.5.5* and *Pt 6, Ch 2, 14.5 Hazardous zones and spaces 14.5.5*;
- (c) zones within a 1,5 m radius of ventilation outlets, hatches or doorways or other openings into spaces defined by *Pt 6, Ch 2, 14.5 Hazardous zones and spaces 14.5.7* or *Pt 6, Ch 2, 14.5 Hazardous zones and spaces 14.5.7*, or within 1,5 m of the ventilation outlets of spaces regarded by *Pt 6, Ch 2, 14.7 Ventilation* as open areas and which contain the pipework or equipment defined by *Pt 6, Ch 2, 14.5 Hazardous zones and spaces 14.5.5* or *Pt 6, Ch 2, 14.5 Hazardous zones and spaces 14.5.5*. Where the hazard results from flammable gas or vapour having a density relative to that of air of more than 0,75, the hazardous zone is considered to extend vertically downward to solid deck, or for a distance of 9 m, whichever is the lesser;
- (d) zones on open deck, or semi-enclosed spaces on open deck, within 3 m of the ventilation outlets of cargo tanks defined in *Pt 6, Ch 2, 14.5 Hazardous zones and spaces 14.5.5*, which permit the flow of small volumes of vapour or gas mixtures caused by thermal variation;
- (e) zones within a 1,5 m radius of flanged joints, or glands or other openings defined by *Pt 6, Ch 2, 14.5 Hazardous zones and spaces 14.5.5*; in the case of gas or vapour having a relative density of more than 0,75, the hazardous zone is considered to extend vertically downwards as described under *Pt 6, Ch 2, 14.5 Hazardous zones and spaces 14.5.7*;
- (f) zones within a 1,5 m radius of flanged joints, or glands or other openings defined by *Pt 6, Ch 2, 14.5 Hazardous zones and spaces 14.5.5* and *Pt 6, Ch 2, 14.5 Hazardous zones and spaces 14.5.5*;
- (g) zones within a 1,5 m radius of bunds or barriers intended to contain spillage of liquids defined by *Pt 6, Ch 2, 14.5 Hazardous zones and spaces 14.5.5*;
- (h) zones on open deck within a 1,5 m radius of any opening into a space defined by *Pt 6, Ch 2, 14.5 Hazardous zones and spaces 14.5.7*; and
- (i) enclosed or semi-enclosed spaces with direct opening into a **zone 1** hazardous location.

14.5.8 The following zones or spaces are regarded as hazardous, **zone 2**:

- (a) ventilated spaces separated by a single bulkhead or deck from a **zone 0** space;
- (b) zones on open deck extending 1,5 m beyond those defined by *14.5.7Pt 6, Ch 2, 14.5 Hazardous zones and spaces 14.5.7*, *Pt 6, Ch 2, 14.5 Hazardous zones and spaces 14.5.7*, *Pt 6, Ch 2, 14.5 Hazardous zones and spaces 14.5.7*, *Pt 6, Ch 2, 14.5 Hazardous zones and spaces 14.5.7* or *Pt 6, Ch 2, 14.5 Hazardous zones and spaces 14.5.7*;
- (c) zones on open deck extending 2 m beyond those defined by *Pt 6, Ch 2, 14.5 Hazardous zones and spaces 14.5.7*;
- (d) zones within a 1,5 m radius of ventilation inlets serving spaces defined by *Pt 6, Ch 2, 14.5 Hazardous zones and spaces 14.5.7*; and
- (e) enclosed or semi-enclosed spaces with direct opening into a **zone 2** hazardous location.

14.6 Semi-enclosed spaces

14.6.1 Semi-enclosed spaces are considered to be spaces limited by decks and/or bulkheads in such a manner that the natural conditions of ventilation are sensibly different from those obtained on open deck.

14.7 Ventilation

14.7.1 Where an enclosed or semi-enclosed space is provided with mechanical ventilation ensuring at least 12 air changes/hour, and leaving no areas of stagnant air, it may be regarded in consideration of hazardous zones as would otherwise be defined by *Pt 6, Ch 2, 14.5 Hazardous zones and spaces 14.5.6, Pt 6, Ch 2, 14.5 Hazardous zones and spaces 14.5.7 or Pt 6, Ch 2, 14.5 Hazardous zones and spaces 14.5.7 and Pt 6, Ch 2, 14.5 Hazardous zones and spaces 14.5.8*, as an open area.

14.7.2 Where the rate of ventilation air flow, in relation to the maximum rate of release of flammable substances reasonably to be expected under normal conditions, is sufficient to prevent the concentration of flammable substances approaching their lower explosive limit, consideration may be given to regarding as non-hazardous, the space, ventilation and other openings into it, and the zone around the equipment contained within.

14.7.3 An alarm is to be provided on the navigating bridge, engine control room, and where applicable, cargo control room to indicate any loss of the required ventilation capacity.

14.8 Pressurisation

14.8.1 A space having access to a hazardous space or zone defined as **zone 1** or **zone 2** may be regarded as non-hazardous if fulfilling all the following conditions:

- (a) access is by means of an air-lock, having gastight steel doors, the inner of which as a minimum, is self-closing without any hold-back arrangement;
- (b) it is maintained at an overpressure relative to the external hazardous area by ventilation from a non-hazardous area;
- (c) the relative air pressure within the space is continuously monitored and so arranged that, in the event of loss of overpressure, an alarm is given and the electrical supply to all equipment not of a type suitable for **zone 1** is automatically disconnected. Where the shutdown of equipment could introduce a hazard, an alarm may be given, in lieu of shutdown, upon loss of overpressure, and a means of disconnection of electrical equipment not of a type suitable for **zone 1**, capable of being controlled from an attended station, provided in conjunction with an agreed operational procedure; where the means of disconnection is located within the space then it is to be effected by equipment of a type suitable for **zone 1**;
- (d) any electrical equipment required to operate upon loss of overpressure, lighting fittings (see *Pt 6, Ch 2, 5.7 Lighting circuits 5.7.3*) and equipment within the air-lock, is to be of a type suitable for **zone 1**; and
- (e) means are to be provided to prevent electrical equipment, other than of a type suitable for **zone 1**, being energised until the atmosphere within the space is made safe, by air renewal of at least 10 times the capacity of the space.

14.8.2 A space having access to a hazardous space or zone defined as **zone 2** may be regarded as non-hazardous if fulfilling all the following conditions:

- (a) access is by means of a self-closing gastight steel door without any hold-back arrangement;
- (b) it is maintained at an overpressure relative to the external hazardous area by ventilation from a non-hazardous area;
- (c) the relative air pressure within the space is continuously monitored and so arranged that, in the event of loss of overpressure, an alarm is given. A means of disconnection of electrical equipment not of a type suitable for **zone 2** is to be provided; where the means of disconnection is located within the space then it is to be effected by equipment of a type suitable for **zone 2**;
- (d) any electrical equipment required to operate upon loss of overpressure (e.g. lighting fittings, see *Pt 6, Ch 2, 5.7 Lighting circuits 5.7.3*), is to be of a type suitable for **zone 2**.

14.9 Cable and cable installation

14.9.1 Electric cables are not, as far as is practicable, to be installed in hazardous zones or spaces, except where serving equipment installed within the zone or space. Through runs of cable may be accepted in locations classified as **zone 1** or **zone 2**, where alternative routes are impracticable.

14.9.2 In addition to the requirements of *Pt 6, Ch 2, 11 Electric cables, optical fibre cables and busbar trunking systems (busways)*, cables for circuits that are not intrinsically safe, which are located in hazardous zones or spaces, or which may be exposed to cargo oil, oil vapour or gas, are to be either:

- (a) mineral insulated with copper sheath, or
- (b) armoured or braided for earth detection,

- (c) otherwise adequately protected against mechanical or chemical damage, within **zone 2** or non-hazardous locations only, or
 (d) as otherwise specifically permitted elsewhere within this Section.

14.9.3 Armouring, braiding and other metal coverings of cables installed in dangerous zones or spaces are to be effectively earthed at least at both ends.

14.9.4 Where there is risk of intermittent contact between armour and exposed metalwork, non-metallic impervious sheath is to be applied over metallic armour of cables.

14.9.5 Cables associated with intrinsically safe circuits are to be used only for such circuits. They are to be physically separated from cables associated with non-intrinsically safe circuits, e.g. neither installed in the same protective casing nor secured by the same fixing clip. Consideration may be given to other arrangements complying with IEC 60079-14: *Explosive atmospheres– Part 14: Electrical installations design, selection and erection*.

14.9.6 In **zone 0**, cable joints may only be used in intrinsically safe circuits.

14.9.7 Cable runs in **zone 1** or **zone 2** are, where practicable, to be uninterrupted. Where discontinuities cannot be avoided, cable joints are, additionally, to:

- be made in an enclosure with a type of protection appropriate to the location; or
- provided the joint is not subject to mechanical stress, be epoxy filled, compound-filled or sleeved with heat-shrunk tubing, in accordance with the manufacturer's instructions.

14.10 Requirements for tankers intended for the carriage in bulk of oil cargoes having a flash point not exceeding 60°C (closed-cup test)

14.10.1 In order to eliminate potential sources of ignition from hazardous areas on board tankers in accordance with SOLAS - *International Convention for the Safety of Life at Sea* as amended, Chapter II-1, *Regulation 45 - Precautions against shock, fire and other hazards of electrical origin (Paragraphs 10 and 11 of this regulation apply to ships constructed on or after 1 January 2007)*, electrical equipment is to be selected and installed in accordance with IEC 60092: *Electrical installations in ships – Part 502: Tankers – Special features*.

14.10.2 The relevant group and temperature class for electrical equipment in hazardous zones are, respectively, IIA and T3.

14.11 Requirements for ships for the carriage of liquefied gases in bulk

14.11.1 See 18, *Ch 10 Electrical Installations* of the Rules for Ships for Liquefied Gases.

14.12 Requirements for ships intended for the carriage in bulk of other flammable liquid cargoes

14.12.1 See *Ch 1, 10.1 General* of the Rules for Ships for Liquid Chemicals.

14.13 Special requirements for ships with spaces for carrying vehicles with fuel in their tanks, for their own propulsion

14.13.1 Passenger ships with special category spaces above the bulkhead deck for carrying vehicles:

- (a) electrical equipment fitted within a height of 45 cm above the vehicle deck, or any platform on which vehicles are carried, or within the exhaust ventilation trunking for the space, is to be of a type acceptable for **zone 1**;
- (b) electrical equipment situated elsewhere within the space is to be of a type acceptable for **zone 2**, or is to have an enclosure of ingress protection rating of at least IP55, see IEC 60529: *Degrees of protection provided by enclosures (IP Code)*. Smoke and gas detector heads are exempt from this requirement.

14.13.2 **Passenger ships with special category spaces below the bulkhead deck for carrying vehicles:** electrical equipment fitted within the space and within the exhaust ventilation trunking for the space, is to be of a type acceptable for **zone 1**.

14.13.3 Passenger ship with cargo spaces, other than special category spaces, for carrying vehicles:

- (a) electrical equipment within such a cargo space, or within the exhaust ventilation trunking for the space, is to be of a type acceptable for **zone 1**;
- (b) all electrical circuits terminating in the cargo space are to be provided with multipole linked isolating switches located outside the cargo hold. Provision is to be made for locking in the off position. This does not apply to safety circuits such as those for fire, smoke or gas detection.

14.13.4 Cargo ships with closed ro-ro cargo spaces for carrying vehicles:

- (a) except where exempted by (b) electrical equipment fitted within the space and within the exhaust ventilation trunking for the space is to be of a type acceptable for **zone 1**;
- (b) where the ventilation system required by SOLAS - *International Convention for the Safety of Life at Sea* as amended, Chapter II-2, *Regulation 20 - Protection of vehicle, special category and ro-ro spaces*, 20.3.1.1 is arranged to operate continuously and is sufficient to provide at least ten air changes per hour, whenever vehicles are on board, above a height of 45 cm from the vehicle deck, or any platform on which vehicles are carried, electrical equipment is to be of a type acceptable for **zone 2**, or is to have an enclosure of ingress protection rating of at least IP 55;
- (c) all electrical circuits terminating in the cargo space are to be provided with multipole linked isolating switches located outside the cargo hold. Provision is to be made for locking in the off position. This does not apply to safety circuits such as those for fire, smoke or gas detection.

14.13.5 Vehicle carriers with spaces for carrying vehicles with compressed natural gas in their tanks, for their own propulsion:

- electrical equipment fitted within the space and within any ventilation trunking for the space, is to be of a type acceptable for **zone 1**. See also *Pt 6, Ch 2, 14.2 Selection of equipment for use in explosive gas atmospheres 14.2.7*.

14.13.6 Vehicle carriers with spaces for carrying vehicles with compressed hydrogen in their tanks for their own propulsion:

- electrical equipment fitted within the space and within any ventilation trunking for the space, is to be of a type acceptable for **zone 1**. See also *Pt 6, Ch 2, 14.2 Selection of equipment for use in explosive gas atmospheres 14.2.7*.

14.14 Special requirements for ships intended for the carriage of dangerous goods and materials hazardous only in bulk

14.14.1 In order to eliminate potential sources of ignition in enclosed cargo spaces or vehicle spaces in accordance with SOLAS - *International Convention for the Safety of Life at Sea* as amended, Chapter II-2, *Regulation 19 - Carriage of dangerous goods*, and from associated hazardous areas (see *Pt 6, Ch 2, 14.5 Hazardous zones and spaces 14.5.3*), electrical equipment is to be selected in accordance with *Pt 6, Ch 2, 14.14 Special requirements for ships intended for the carriage of dangerous goods and materials hazardous only in bulk 14.14.2* and *Pt 6, Ch 2, 14.14 Special requirements for ships intended for the carriage of dangerous goods and materials hazardous only in bulk 14.14.3* and installed in accordance with *Pt 6, Ch 2, 14.4 Installation of electrical equipment* and *Pt 6, Ch 2, 14.14 Special requirements for ships intended for the carriage of dangerous goods and materials hazardous only in bulk 14.14.4* to *14.14.7*.

14.14.2 Electrical equipment essential for the safety and operation of the ship is to be of a type providing protection against ignition of the gases and/or dusts that can be present, selected in accordance with IEC 60092-506: *Electrical installations in ships – Part 506: Special features – Ships carrying specific dangerous goods and materials hazardous only in bulk*.

14.14.3 In addition to the requirements of IEC 60092- 506: *Electrical installations in ships – Part 506: Special features – Ships carrying specific dangerous goods and materials hazardous only in bulk*, pipes such as ventilation and bilge pipes, having ends opening into a hazardous area are to be considered a hazardous area. Enclosed spaces such as pipe tunnels and bilge pump-rooms containing such pipes and with equipment and components such as pumps, valves and flanges are to be considered as extended hazardous areas unless protected by overpressure.

14.14.4 Electrical equipment not essential for the safety or operation of the ship and which is not of a type providing protection against ignition of the gases and/or dusts that can be present is to be completely disconnected and protected against unauthorised re-connection. Disconnection is to be made outside the hazardous areas and be effected with isolating links or lockable switches.

14.14.5 Electrical equipment and all cables, including through runs and terminating cables, are to be protected against mechanical damage. Cables are to be either enclosed in screwed heavy gauge steel drawn or seam-welded and galvanised conduit, or protected by electrically continuous metal sheathing or metallic wire armour braid or tape.

14.14.6 Cable penetrations of decks and bulkheads are to be sealed against the passage of gas or vapour.

14.15 Requirements for ships with spaces for storing paint

14.15.1 In order to eliminate potential sources of ignition in paint stores, electrical equipment is to be selected as follows:

- (a) electrical equipment fitted within the space and within the exhaust ventilation trunking for the space is to be of a type acceptable for **zone 1**;

(b) electrical equipment situated within 1 m of inlet and exhaust ventilation openings or within 3 m of exhaust mechanical ventilation outlets is to be of a type acceptable for **zone 2**, or is to have an enclosure of ingress protection rating of at least IP55, see IEC 60529, *Classification of Degrees of Protection Provided by Enclosures*. See Pt 6, Ch 2, 1.11 Location and construction 1.11.1 for degrees of protection required for equipment on open deck.

14.15.2 A space having access to a paint store may be regarded as non-hazardous if fulfilling all of the following conditions:

- (a) access is by means of a self-closing gastight steel door without any hold-back arrangement;
- (b) the paint store is ventilated from a non-hazardous area and;
- (c) warning notices are fitted adjacent to the paint store entrance warning of flammable liquids contained in paint store.

Note A watertight door may be considered as being gastight.

14.15.3 The relevant group and temperature class for electrical equipment in hazardous zones are, respectively, IIB and T3.

■ Section 15 Navigation and manoeuvring systems

15.1 Steering gear

15.1.1 The requirements of Pt 6, Ch 2, 15.1 Steering gear 15.1.2 to Pt 6, Ch 2, 15.1 Steering gear 15.1.5 are to be read in conjunction with those in Pt 5, Ch 19, 5 Electric power circuits, electric control circuits, monitoring and alarms.

15.1.2 Two exclusive circuits, fed from the main source of electrical power and each having adequate capacity to supply all the motors which may be connected to it simultaneously are to be provided for each electric or electrohydraulic steering gear arrangement consisting of one or more electric motors. One of these circuits may pass through the emergency switchboard, see also Pt 5, Ch 19, 6 Emergency power.

15.1.3 The motor of an associated auxiliary electric or electrohydraulic power unit may be connected to one of the circuits supplying the main steering gear.

15.1.4 Any main and auxiliary steering gear electrical control system and steering gear motors operable from the navigational bridge are to comply with SOLAS Ch II-1, Part C, Regulation 29 - Steering gear1, Section 8 and SOLAS Ch II, Part C, Regulation 29 - Steering gear1 Section 5.

15.1.5 In ships of less than 1600 gross tonnage, if an auxiliary steering gear is not electrically powered or is powered by an electric motor primarily intended for other services, the main steering gear may be fed by one circuit from the main switchboard. Consideration would be given to other protective arrangements other than described in Pt 6, Ch 2, 15.1 Steering gear 15.1.4 for such a motor primarily intended for other services.

15.2 Thruster systems for steering

15.2.1 Where azimuth or rotatable thruster units, used as the sole means of steering, are electrically driven the requirements of Pt 5, Ch 20, 5.1 General are to be complied with.

15.3 Thruster systems for dynamic positioning

15.3.1 For ships having a **DP** notation the requirements of Pt 7, Ch 4 Dynamic Positioning Systems are to be complied with.

15.4 Thruster systems for manoeuvring

15.4.1 Where a thruster unit is fitted solely for the purpose of manoeuvring, and is electrically driven, its starting and operation is not to cause the loss of any essential services.

15.4.2 In order to ensure that the thruster system is not tripped inadvertently whilst manoeuvring the ship, overload protection in the form of an alarm is to be provided for the electric motor and any associated supply converters, in lieu of tripping.

15.4.3 The thruster unit electric motor is not to be disconnected as part of a load management switching operation.

15.5 Transverse thrust units

15.5.1 Where transverse thrust units are remotely controlled, means are to be provided at the remote control station to stop the propulsion unit.

15.5.2 Transverse thrust units are to be provided with indications of direction and magnitude of thrust and propeller pitch at each station from which it is possible to control justify the propeller pitch.

15.6 Navigation lights

15.6.1 Navigation lights are to be connected separately to a distribution board reserved for this purpose only and accessible to the officer of the watch. This distribution board is to be connected directly or through transformers to the emergency source of electrical power in compliance with, for passenger ships, *Pt 6, Ch 2, 3.3 Emergency source of electrical power in passenger ships 3.3.1* or, for cargo ships, *Pt 6, Ch 2, 3.4 Emergency source of electrical power in cargo ships 3.4.1*. An alarm is to be activated in the event of failure of a power supply from the distribution board.

15.6.2 Each navigation light is to be controlled and protected in each insulated pole by a switch and fuse or circuit-breaker mounted on the distribution board.

15.6.3 Provision is to be made on the navigating bridge for the navigation lights to be transferred to an alternative circuit fed from the main source of electrical power.

15.6.4 Each navigation light is to be provided with an automatic indicator giving audible and/or visual indication of failure of the light. If an audible device alone is fitted, it is to be connected to an independent source of supply, e.g. a battery, with means provided to test this supply. If a visual signal is used connected in series with the navigation light, means are to be provided to prevent extinction of the navigation light due to failure of the signal. The requirements of this paragraph do not apply to tugs, trawlers and similar small vessels.

15.6.5 For navigation lights using light emitting diodes (consisting of multiple light sources) means to ensure that the overall luminous intensity of the navigation light is sufficient are to be provided in addition to the alarm to indicate the complete loss of the navigation light illumination required by *Pt 6, Ch 2, 15.6 Navigation lights 15.6.4*. For replacement navigation lights, see *Pt 6, Ch 2, 1.5 Additions or alterations 1.5.5*.

15.6.6 To satisfy *Pt 6, Ch 2, 15.6 Navigation lights 15.6.5*, an audible and visual alarm is to be activated to notify the Officer of the Watch when the luminous intensity of the light reduces below the level required by the *IMO Convention on the International Regulations for Preventing Collisions at Sea*. Alternative measures to ensure continuing acceptable performance of navigation lights using light emitting diodes may be considered that are in accordance with:

- *IMO Resolution MSC.253(83) - Adoption of the Performance Standards for Navigation Lights, Navigation Light Controllers and Associated Equipment - (Adopted on 8 October 2007)*, and
- *EN 14744, Inland navigation vessels and sea-going vessels – Navigation light*, or a relevant National or International Standard.

Where alternative measures are proposed that require verification by personnel of the luminous intensity of navigation lights using light emitting diodes, details of the inspection implementation in the ship's safety management system and acceptance by the National Administration are to be submitted for consideration.

15.6.7 Navigation light power supply units installed to convert, control and/or monitor the distribution board power supply required by *Pt 6, Ch 2, 15.6 Navigation lights 15.6.1* above for connection to the light source(s) (e.g. for LED type navigation lights) are, in the event of a short-circuit on the unit output, to disconnect or limit the supply to prevent further damage and activate an alarm.

15.6.8 Navigation light power supply units are to be self-checking, detecting failures of the unit itself and activating an alarm. These are to include:

- detection of system lock-ups (program hangs);
- means to detect failure of navigation light switching command input circuits or links; and
- means to detect failure of the navigation light monitoring arrangements required to provide the alarms required by *Pt 6, Ch 2, 15.6 Navigation lights 15.6.4* and *Pt 6, Ch 2, 15.6 Navigation lights 15.6.5*, as applicable.

15.6.9 The navigation light power supply failure alarms required by *Pt 6, Ch 2, 15.6 Navigation lights 15.6.1* are not to be displayed as a group alarm. Other navigation light alarms may be grouped for each navigation light where means are provided for personnel to determine the cause of the alarm. Activation of more than one of the navigation light alarms as a result of a single failure is to be prevented.

15.6.10 Any statutory requirements of the country of registration are to be complied with and may be accepted as an alternative to the above.

15.7 Navigational aids

15.7.1 Navigational aids as required by SOLAS are to be fed from the emergency source of electrical power, see also *Pt 6, Ch 2, 3.3 Emergency source of electrical power in passenger ships 3.3.1* and *Pt 6, Ch 2, 3.4 Emergency source of electrical power in cargo ships 3.4.1*.

15.7.2 For ships having a notation **NAV1** navigational aids are to have an alternative supply fed from the main source of electrical power, independent of the emergency switchboard, with automatic changeover facilities.

■ Section 16 **Electric propulsion**

16.1 General

16.1.1 Where the arrangements permit a propulsion motor to be connected to a generating plant having a continuous rating greater than the motor rating, means are to be provided to limit the continuous input to the motor to a value not exceeding the continuous full load torque for which the motor and shafts are approved.

16.1.2 The ventilation and cooling systems for electrical propulsion equipment are to be provided with monitoring devices arranged to operate an alarm if the temperature of the heated cooling medium exceeds a predetermined safe value.

16.1.3 The embedded temperature detectors required by *Pt 6, Ch 2, 9.1 General requirements 9.1.10* are to be arranged to operate an alarm if the temperature exceeds a predetermined safe value.

16.1.4 Propulsion motors, generators and converters are to be provided with means to prevent the accumulation of moisture and condensate when operating at low power levels, or when idle.

16.2 System design and arrangement

16.2.1 In general, for a ship to be assigned an unrestricted service notation, it is to have two independently driven propellers or other propulsion devices, each connected with at least one electric motor, where these form the sole means of propulsion.

16.2.2 For vessels where a propulsion device driven by electric motors is proposed as the sole means of propulsion, at least two effective, independent electric propulsion motors are to be provided and the system is to be designed in accordance with *Pt 7, Ch 14 Requirements for Machinery and Engineering Systems of Unconventional Design*. The risk management is to identify components where a failure could cause loss of propulsion power or other essential services and the proposed arrangements for preventing and mitigating the effects of such a failure.

16.3 Power requirements

16.3.1 The propulsion system is to have sufficient power for manoeuvring the vessel and for going astern. With the ship travelling at its maximum service speed the propulsion equipment is to be capable of stopping and reversing the ship in an agreed time.

16.3.2 The propulsion system is to have adequate torque and power margins for all operating conditions including manoeuvring and rough weather with due regard to propeller and ship characteristics.

16.3.3 The electric power for the propulsion system may be derived from generating sets dedicated to propulsion duty or from a central power generation plant which serves both propulsion and ship service loads.

16.3.4 Where propulsion power is derived from a central, common, power plant the control system is to ensure a safe distribution of power between propulsion and ship services, with tripping of non-essential loads and/or reduction in propulsion power if necessary.

16.3.5 Where a central power generation system is employed the number and rating of generator sets is to be such that with one set out of action the remaining sets are capable of providing all essential and normal ship service loads whilst maintaining an effective level of propulsion power.

16.3.6 Where, in a central power generation system, the electrical power requirements are normally supplied by two or more generating sets operating in parallel, on sudden loss of power from one set, the rating of the remaining set(s) in service is to be sufficient to ensure uninterrupted operation of essential services and an effective level of propulsion power.

16.3.7 Where a central power generation system is employed, means are to be provided to connect available generator sets to meet the power requirement of the electric propulsion system. Arrangements are to be in place to prevent generator sets being automatically disconnected during ship manoeuvres.

16.3.8 Where forced cooling is used on propulsion motors it is to be possible to operate the motor at a defined reduced power level in the event of failure of the forced cooling.

16.3.9 Total harmonic distortion of the a.c. voltage waveform up to 10 per cent on electric propulsion circuits, not directly connected to the main source of electrical power, may be considered where details are submitted which demonstrate that the equipment and systems are capable of operating under such conditions.

16.4 Propulsion control

16.4.1 Propulsion control systems are to be stable throughout their normal operating range and arranged to attenuate any effects of cyclic propeller load fluctuations caused by wave action.

16.4.2 Step-less control of propeller speed, and/or pitch, from zero to full power ahead or astern is to be provided.

16.4.3 The control system is to ensure that there is no dangerous overspeeding of propulsion motors upon loss of load.

16.4.4 Interlocks are to be provided in the control system to ensure that ahead and astern circuits are not energised simultaneously.

16.4.5 Any single fault in either the propulsion machine excitation or power distribution systems is not to result in a total loss of propulsion power.

16.4.6 Control, alarm and safety systems for the propulsion system are to satisfy the requirements of *Pt 6, Ch 1 Control Engineering Systems*.

16.4.7 Each control station is to be provided with an emergency stop function for the propulsion motors. The emergency stop function is to be independent of the normal control system.

16.4.8 The control system is to limit the propulsion power if the power available from the generator(s) is not sufficient to supply the demand level of propulsion power. In the event of a power limitation, there is to be a visual indication at the control stations.

16.4.9 Means are to be provided to identify the cause of propulsion motor power limitation or automatic reduction (e.g. excessive load torque, cooling failure, high temperature, power availability).

16.4.10 Local controls are to be provided, independent of any remote or automatic system, to permit effective control of the propulsion equipment.

16.4.11 Control systems are not to share hardware or data communication links with control, safety and alarm systems not associated with propulsion control, *see also Pt 6, Ch 1, 2.11 Data communication links*.

16.5 Protection of propulsion system

16.5.1 Provision is to be made for protection against severe overloads, and electrical faults likely to result in damage to plant.

16.5.2 Propulsion motors are to be capable of withstanding, without damage, the thermal and mechanical effects of a short-circuit at the terminals.

16.5.3 Electric motors of podded propulsion units, and/or having permanent magnet excitation, are to be provided with a protective device which, in the event of a short-circuit in the motor or in the cables between the motor and its circuit-breaker, will instantaneously open the circuit-breaker and, in motors with electromagnetic excitation, de-excite the motor. Motors with permanent magnet main excitation are to be provided with means to prevent further damage as a result of continued rotation after disconnection (e.g. shaft brake).

16.5.4 Safeguards for protecting propulsion equipment against damage resulting from earth faults are to be as specified by the equipment manufacturer. Where the fault current flowing is liable to cause damage to the electrical equipment there are to be arrangements for interrupting the current automatically.

16.5.5 For the protection of electrical equipment and cables against overvoltages means are to be provided for limiting the induced voltage when field windings, and other inductive circuits are opened. Protective resistors and devices are to be sized to cater for the likely extreme operating conditions.

16.5.6 An alarm is to be initiated when the excitation system of electric generators providing propulsion power is overloaded such that damage due to heating could occur in the generator or its cabling.

16.5.7 Where, on stopping or reversing the propeller, regenerated energy is produced by the propulsion motor this is not to cause a dangerous increase of speed in the prime mover or a dangerous overvoltage condition on the supply system. Where a central power generation system is used then the voltage and frequency fluctuations are not to exceed the limits given in *Pt 6, Ch 2, 1.8 Quality of power supplies*.

16.5.8 Dynamic braking resistors are to be suitably rated for their expected operation.

16.5.9 Propulsion converters are to be capable of withstanding, without damage, the thermal and mechanical effects of a short-circuit at the terminals or connection to a propulsion motor with a stalled or locked rotor.

16.5.10 Loss of flow of air or liquid cooling of propulsion converters, where used, is to initiate an alarm at an attended control position. Loss of flow of air or liquid cooling is not to result in immediate damage to the propulsion converter, see *Pt 6, Ch 2, 10.2 Semiconductor converters 10.2.4*.

16.5.11 Alarms and safeguards for electric propulsion equipment are indicated in *Table 2.16.1 Electric propulsion equipment: Alarms and safeguards*.

Table 2.16.1 Electric propulsion equipment: Alarms and safeguards

Item	Alarm	Note
Electric propulsion equipment ventilation and cooling medium temperature	High	See <i>Pt 6, Ch 2, 16.1 General 16.1.2</i> and <i>Pt 6, Ch 2, 16.3 Power requirements 16.3.8</i>
Electric propulsion transformer winding temperature	High	See <i>Pt 6, Ch 2, 10.1 Transformers 10.1.11</i>
Electric propulsion generator excitation	Overload	See <i>Pt 6, Ch 2, 16.5 Protection of propulsion system 16.5.6</i>
Electric propulsion generators and motors winding temperature	High	See <i>Pt 6, Ch 2, 16.1 General 16.1.3</i>
Electric propulsion generator and motor bearing temperature	High	See <i>Pt 6, Ch 2, 9.1 General requirements 9.1.11</i>
Electric propulsion generator and motor lubricating oil supply pressure	Low	See <i>Pt 6, Ch 2, 9.1 General requirements 9.1.12</i>
Electric propulsion generator and motor lubricating oil temperature	High	See <i>Pt 6, Ch 2, 9.1 General requirements 9.1.13</i>

16.6 Instruments

16.6.1 The main control station is to be provided with the following instruments:

- (a) a.c. systems:
 - (i) an ammeter for each generator, propulsion motor and propulsion transformer primary; voltmeter, wattmeter and frequency meter for each generator and ammeter for each excitation circuit; and
 - (ii) a temperature indicator for each generator, propulsion transformer and propulsion motor windings and bearings, the indicator is to read stator winding temperature of the rotating machines, and cooling system temperature.
- (b) d.c. systems:
 - (i) a voltmeter and ammeter for each generator and propulsion motor; and
 - (ii) an ammeter for each excitation circuit.

16.6.2 Each control station is to be provided with instruments to indicate:

- (a) propeller speed;
- (b) direction of rotation for a fixed pitch propeller or pitch position for a controllable pitch propeller;
- (c) visual indication of power limitation; and
- (d) indication of station in control.

■ Section 17**Fire safety systems****17.1 Fire detection and alarm systems**

17.1.1 Fire detection and alarm systems are to comply with Chapter 9 of the *Fire Safety Systems Code* (FSS Code) and *Pt 6, Ch 2, 17.1 Fire detection and alarm systems 17.1.2*.

17.1.2 Fire detection and alarm systems are to be provided with at least two power supplies from the main and emergency switchboards and automatic changeover facilities as directed by *FSS Code - Fire Safety Systems – Resolution MSC.98(73) 2.2.1*. Failure of any power supply is to operate an audible and visual alarm in accordance with the *Code on Alerts and Indicators, 2009*.

17.1.3 Where an accumulator battery provides a power supply, on restoration of the main source of electrical power, the rating of the charge unit is to be sufficient to recharge the battery while maintaining the output supply to the fire detection and alarm system.

17.1.4 A loop circuit of an addressable fire detection system, capable of remotely identifying from either end of the loop each detector and manually operated call point served by the circuit, may serve spaces on both sides of the ship and on several decks, but is not to be situated in more than one main vertical or horizontal fire zone, nor is a loop circuit which covers an accommodation space, service space and/or control station to include a machinery space of Category A.

17.1.5 A loop circuit of an addressable fire detection system may comprise one or more sections. Where the loop comprises more than one section, the sections are to be separated by devices which will ensure that, if a short-circuit occurs anywhere in the loop, only the affected section will be isolated from the control panel. No section of detectors and manually operated call points is in general to include more than 50 detectors.

17.1.6 Where the fire detection system does not include means of remotely identifying each detector and manually operated call point individually, it is to be in accordance with the *FSS Code Chapter 9 – Fixed fire detection and fire alarm systems 2.4.1.3*.

17.1.7 A section of fire detectors and manually operated call points is not to be situated in more than one main vertical zone.

17.1.8 The wiring for each section of detectors and manually operated call points in an addressable fire detector system is to be separated as widely as practicable from that of all other sections on the same loop. Where practicable no loop is to pass through a space twice. When this is not practicable, such as in large public spaces, the part of the loop which by necessity passes through the space for a second time is to be installed at the maximum possible distance from other parts of the loop.

17.2 Automatic sprinkler system

17.2.1 Any electrically driven power pump, provided solely for the purpose of continuing automatically the discharge of water from the sprinklers, is to be brought into action automatically by the pressure drop in the system before the standing fresh water charge in the pressure tank is completely exhausted.

17.2.2 For **passenger ships**, electrically driven sea-water pumps for automatic sprinkler systems are to be in accordance with *FSS Code Chapter 8 - Automatic Sprinkler, Fire Detection and Fire Alarm Systems, Section 2.2.1*.

17.2.3 The automatic alarm and detection system is to be fed by exclusive feeders from two sources of electrical power, one of which is to be an emergency source, with automatic changeover facilities located in, or adjacent to, the main alarm and detection panel.

17.2.4 Feeders for the sea-water pump and the automatic alarm and detection system are to be arranged so as to avoid galleys, machinery spaces and other enclosed spaces of high fire risk, except in so far as it is necessary to reach the appropriate switch boards. The cables are to be of a fire resistant type where they pass through such high risk areas.

17.3 Fixed water-based local application fire-fighting systems

17.3.1 Where fixed water-based local application fire-fighting system pressure sources are reliant on external power they need only be supplied by the main source of electrical power.

17.3.2 The fire detection, control and alarm systems are to be provided with an emergency source of electrical power required by *Pt 6, Ch 2, 3.3 Emergency source of electrical power in passenger ships* or *Pt 6, Ch 2, 3.4 Emergency source of electrical power in cargo ships* and are also to be connected to the main source of electrical power. Separate feeders, reserved solely for this purpose, with automatic changeover facilities located in, or adjacent to, the main control panel are to be provided.

17.3.3 Failure of any power supply is to operate an audible and visual alarm. See also *Pt 6, Ch 2, 1.14 Alarms* and *Pt 6, Ch 2, 1.15 Labels, signs and notices*.

17.3.4 Means to activate a system are to be located at easily accessible positions inside and outside the protected space. Arrangements inside the space are to be situated such that they will not be cut off by a fire in the protected areas and are suitable for activation in the event of escape. Where it is proposed to install local activation means outside of the protected space, details are to be submitted for consideration.

17.3.5 For the electrical safety of electrical and electronic equipment in areas protected by fixed water-based local application fire-fighting systems and adjacent areas where water may extend, the requirements of *Pt 6, Ch 2, 17.3 Fixed water-based local application fire-fighting systems 17.3.6* to *Pt 6, Ch 2, 17.3 Fixed water-based local application fire-fighting systems 17.3.10* apply.

17.3.6 As far as is practicable, electrical and electronic equipment is not to be located within protected areas or adjacent areas. The system pump, its electrical motor and the sea valve if any, may be in a protected space provided that they are outside areas where water or spray may extend.

17.3.7 High voltage equipment and their enclosures are not to be installed in protected areas or adjacent areas. For high voltage generators enclosures which cannot be fully located outside of adjacent areas due to close proximity, a technical justification, including proposed degree of protection ratings that are normally not to be lower than IP54, may be submitted for consideration that demonstrates the overall safety of the installation in the event of system operation.

17.3.8 In addition to the degree of protection requirements of *Pt 6, Ch 2, 1.11 Location and construction 1.11.1*, electrical and electronic equipment enclosures located within protected areas and within adjacent areas are to provide adequate protection in the event of system operation.

17.3.9 To demonstrate compliance with *Pt 6, Ch 2, 17.3 Fixed water-based local application fire-fighting systems 17.3.8*, evidence of the suitability of electrical and electronic equipment for use in protected areas and adjacent areas is to be submitted in accordance with *Pt 6, Ch 2, 1.2 Documentation required for design review 1.2.13*. The evidence is to demonstrate that additional precautions have been taken, where necessary, in respect of:

- (a) satisfying *Pt 6, Ch 2, 17.3 Fixed water-based local application fire-fighting systems 17.3.6* and *Pt 6, Ch 2, 17.3 Fixed water-based local application fire-fighting systems 17.3.7*;
- (b) personnel protection against electric shock;
- (c) cooling airflow, where necessary, for equipment required to operate during system operation; and
- (d) maintenance requirements for equipment before return to operation following system activation.

Any test evidence submitted is to consider the overall installation, including equipment types, system configuration and nozzles and the potential effects of airflows in the protected space.

17.3.10 The evidence required by *Pt 6, Ch 2, 17.3 Fixed water-based local application fire-fighting systems 17.3.9* is to demonstrate the safe and effective operation of the overall arrangements in the event of system operation. This evidence is to demonstrate that exposure to system spray and/or water:

- cannot result in loss of essential services (e.g. unintended activation of automatic machinery shutdown);
- cannot result in loss of availability of emergency services;
- will not affect the continued safe and effective operation of electrical and electronic equipment required to operate during the required period of system operation;
- does not present additional electrical or fire hazards; and
- would require only identified readily replaceable components to be repaired or replaced.

The installation of electrical and electronic equipment required to provide essential or emergency services in enclosures with a degree of protection less than IP44 within areas exposed to direct spray is to be acceptable to LR, and evidence of suitability is to be submitted accordingly.

17.3.11 Fixed water-based local application fire-fighting system electrically driven pumps may be shared with:

- equivalent automatic sprinkler systems;
- equivalent main machinery space fire-fighting systems; or
- local fire-fighting systems for deep-fat cooking equipment;

provided that the shared use is accepted by the National Administration as complying with applicable statutory regulations and the arrangements comply with the requirements of *Pt 6, Ch 2, 17.3 Fixed water-based local application fire-fighting systems 17.3.12* to *Pt 6, Ch 2, 17.3 Fixed water-based local application fire-fighting systems 17.3.14*.

17.3.12 Shared electrically driven sea-water pumps are to be served by not less than two circuits reserved solely for this purpose, one fed from the main source of electrical power and one from the emergency source of electrical power. Such feeders are to be connected to an automatic changeover switch situated near the pumps and the switch is to be normally closed to the feeder from the main source of electrical power. No other switches are permitted in the feeders. The switches on the main and emergency switchboards are to be clearly labelled and normally kept closed.

17.3.13 Failure of a component in the power and control system is not to result in a reduction of the total available pump capacity below that required by any of the areas which the system is required to protect. For equivalent automatic sprinkler systems, a failure is not to prevent automatic release or reduce sprinkler pump capacity by more than 50 per cent.

17.3.14 Where fire-fighting systems share fire-fighting pumps, failure of one system is not to prevent activation of the pumps by any other system.

17.4 Fire pumps

17.4.1 When the emergency fire pump is electrically driven, the power is to be supplied by a source other than that supplying the main fire pumps. This source is to be located outside the machinery spaces containing the main fire pumps and their source of power and drive units.

17.4.2 The cables to the emergency fire pump are not to pass through the machinery spaces containing the main fire pumps and their source of power and drive units. The cables are to be of a fire-resistant type where they pass through other high fire risk areas.

17.5 Refrigerated liquid carbon dioxide systems

17.5.1 Where there are electrically driven refrigeration units for carbon dioxide fire-extinguishing systems, one unit is to be supplied by the main source of electrical power and the other unit from the emergency source of electrical power.

17.5.2 Each electrically driven carbon dioxide refrigerating unit is to be arranged for automatic operation in the event of loss of the alternative unit.

17.6 Fire safety stops

17.6.1 In order to limit the fire growth potential in every space of the ship, means for controlling the air supply to the spaces and flammable liquids within the spaces are to be provided.

17.6.2 To control air supply, a means of stopping all forced and induced draught fans, and all ventilation fans serving accommodation spaces, service spaces, control stations and machinery spaces from an easily accessible position outside of the space being served is to be provided. The position is not to be readily cut off in the event of a fire in the spaces served by the fans.

17.6.3 In passenger ships carrying more than 36 passengers, a second means of stopping ventilation fans serving accommodation spaces, service spaces and control stations is to be provided at a position as far apart from the position required by *Pt 6, Ch 2, 17.6 Fire safety stops 17.6.2* as is practicable. At both positions, the controls are to be grouped so that all fans can be stopped from either of the two positions.

17.6.4 A second means of stopping ventilation fans serving machinery spaces is to be provided at a position as far apart from the position required by *Pt 6, Ch 2, 17.6 Fire safety stops 17.6.2* as is practicable. At both positions the controls are to be grouped so that all fans are operable from either of the two positions. The means for stopping machinery space ventilation fans are to be entirely separate from the means for stopping fans serving all other spaces.

17.6.5 In passenger ships, the means of stopping machinery ventilation fans required by *Pt 6, Ch 2, 17.6 Fire safety stops 17.6.2* is to be located at the central control station which is to have safe access from the open deck. The central control station is to be provided with ventilation fan OFF status indications together with a means for restarting the ventilation fans.

17.6.6 In passenger ships and cargo ships, to which SOLAS 1974 as amended applies, exhaust ducts from main laundries, drying rooms and galley ranges are to be fitted with additional remote-control arrangements as required by SOLAS, Chapter II-2, Part C, *Regulation 9 - Containment of fire*, Section 7.

17.6.7 To control flammable liquids, a means of stopping all fuel oil, lubricating oil, hydraulic oil, cargo oil and thermal oil pumps, oil purifiers from outside the spaces being served is to be provided. The position is not to be cut off in the event of a fire.

17.6.8 Means of cutting off all electrical power to the galley except lighting circuits, in the event of a fire, is to be provided outside the galley exits, at positions which will not readily be rendered inaccessible by such a fire. Consideration may be given to relaxing this requirement for supplies to equipment not used for heating or cooking (e.g. alarm and clock systems) that do not present an electrical shock risk to fire-fighting personnel.

17.6.9 Following activation of any fire safety stops, a manual reset is to be provided in order to restart the associated equipment.

17.6.10 Fire safety stop systems are to be designed on the fail safe principle or alternatively the power supplies to, and the circuits of, the fire safety stop systems are to be continuously monitored and an alarm initiated in the event of a fault. Cables are to be of a fire-resistant type, see *Pt 6, Ch 2, 11.5 Construction 11.5.3*. See also *Pt 6, Ch 2, 5.2 Essential services 5.2.1*.

17.7 Fire doors

17.7.1 The electrical power required for the control, indication and alarm circuits of fire doors is to be provided by an emergency source of electrical power as required by *Pt 6, Ch 2, 3.3 Emergency source of electrical power in passenger ships*. In passenger ships carrying more than 36 passengers an alternative supply fed from the main source of electrical power, with automatic change over facilities, is to be provided at the central control station. Failure of any power supply is to operate an audible and visual alarm, see also *Pt 6, Ch 2, 1.14 Alarms* and *Pt 6, Ch 2, 1.16 Operation under fire conditions*.

17.7.2 The control and indication systems for the fire doors are to be designed on the fail-safe principle with the release system having a manual reset.

17.8 Fire dampers

17.8.1 The electrical power required for the control and indication circuits of fire dampers is to be supplied from the emergency source of electrical power.

17.8.2 The control and indication systems for the fire dampers are to be designed on the fail-safe principle with the release system having a manual reset.

17.8.3 In passenger ships and cargo ships, to which SOLAS 1974 as amended applies, where electrically operated fire dampers are fitted in main laundries, drying rooms and galley ranges, they are to be as required by SOLAS, Ch II-2, Part C, *Regulation 9 - Containment of fire, Section 7*.

17.9 Fire-extinguishing media release

17.9.1 Where it is required that alarms be provided to warn of the release of a fire-extinguishing medium, and these are electrically operated, they are to be provided with an emergency source of electrical power, as required by *Pt 6, Ch 2, 3.3 Emergency source of electrical power in passenger ships* or *Pt 6, Ch 2, 3.4 Emergency source of electrical power in cargo ships*, and also connected to the main source of electrical power, with automatic changeover facilities located in, or adjacent to, the fire-extinguishing media release panel, see also *Pt 6, Ch 2, 1.14 Alarms*. Failure of any power supply is to operate an audible and visual alarm, see also *Pt 6, Ch 2, 1.14 Alarms* and *Pt 6, Ch 2, 1.16 Operation under fire conditions*.

17.9.2 The opening of the fire-extinguishing media control cabinet door, or panel, for any purpose, other than for the release of the fire-extinguishing media, is not to cause the loss of any essential services, see *Pt 6, Ch 2, 1.6 Definitions 1.6.1*.

17.10 Safety centre on passenger ships

17.10.1 Passenger ship safety centres required by SOLAS Ch II/2, *Regulation 23 - Special requirements for ro-ro passenger ships* to provide a control station dedicated to assist with the management of emergency situations are to satisfy the requirements of this sub-Section.

17.10.2 The safety centre location, operation, control and monitoring of the safety systems are to be in accordance with SOLAS Chapter II-2, *Regulation 23 - Special requirements for ro-ro passenger ships*.

17.10.3 Operation, control and/or monitoring facilities provided at the safety centre are additional to any dedicated facilities required at other locations by the Rules or the National Administration.

17.10.4 Where arrangements are operated, controlled and/or monitored from the safety centre in accordance with *Pt 6, Ch 2, 17.10 Safety centre on passenger ships 17.10.3*, they are to comply with the relevant requirements of *Pt 6, Ch 1, 2 Essential features for control, alarm and safety systems* in respect of control, alarm and programmable electronic systems.

17.11 Electrically powered air compressors for breathing air cylinders

17.11.1 In passenger ships carrying more than 36 passengers where electrically powered air compressors are installed they are to be in accordance with SOLAS, Chapter II-2, *Regulation 10 - Construction of watertight bulkheads*, Section 10.2.6.

■ *Section 18*

Crew and passenger emergency safety systems**18.1 Emergency lighting**

18.1.1 For the purpose of this Section emergency lighting, transitional emergency lighting and supplementary emergency lighting are hereafter referred to under the generic name 'emergency lighting'.

18.1.2 Emergency lighting provided in compliance with *Pt 6, Ch 2, 3 Emergency source of electrical power* is to be arranged so that a fire or other casualty in the spaces containing the emergency source of electrical power, associated transforming equipment and the emergency lighting switchboard does not render the main lighting system inoperative.

18.1.3 The level of illumination provided by the emergency lighting is to be adequate to permit safe evacuation in an emergency, having regard to the possible presence of smoke, see *Pt 6, Ch 2, 18.4 Escape route or low location lighting (LLL)*.

18.1.4 The exit(s) from every main compartment occupied by passengers or crew is to be continuously illuminated by an emergency lighting fitting.

18.1.5 Switches are not to be installed in the final sub-circuits to emergency light fittings unless the light fittings are serving normally unmanned spaces (e.g. storage-rooms, cold rooms, etc.), or they are normally required to be extinguished for operational reasons (e.g. for night visibility from the navigating bridge). Where switches are fitted they are to be accessible only to ship's crew with provision made to ensure that the emergency lighting is energised when such spaces are manned and/or during emergency conditions.

18.1.6 Where emergency lighting fittings are connected to dimmers, provision is to be made, upon the loss of the main lighting, to automatically restore them to their normal level of illumination.

18.1.7 Fittings are to be specially marked to indicate that they form part of the emergency lighting system.

18.2 General emergency alarm system

18.2.1 An electrically operated bell or klaxon or air-operated whistle with independent air supply or other equivalent warning system installed in addition to the ship's whistle or siren, for sounding the general emergency alarm signal is to comply with the *LSA Code - International Life-Saving Appliance Code – Resolution MSC.48(66)* and with the requirements of this Section, see also *Pt 6, Ch 2, 1.14 Alarms* and *Pt 6, Ch 2, 1.16 Operation under fire conditions*.

18.2.2 The main and emergency sources of supply to the general emergency alarm system shall be in accordance with *LSA Code*, Chapter VII, *7.2 General alarm and public address system*. For General emergency alarm systems refer to the *IMO Code on Alerts and Indicators, 2009, 4 General*.

18.2.3 In conjunction with the *IMO Code on Alerts and Indicators, 2009 4 General* the general emergency alarm distribution system is to be so arranged that a fire or casualty in any one main vertical zone, as defined by SOLAS 1974 as amended Reg II-2/A, *Regulation 3 - Definitions*, other than the zone in which the public address control station is located, will not interfere with the distribution in any other such zone.

18.2.4 There are to be segregated cable routes to public rooms, alleyways, stairways, control stations and on passenger ships on open decks, so arranged that any single electrical fault, localised fire or casualty will not cause the loss of the facility to sound the general emergency alarm in any public rooms, alleyways, stairways, control stations and on passenger ships on open decks, albeit at a reduced capacity.

18.2.5 Where the special alarm fitted to summon the crew, operated from the navigation bridge, or fire control station, forms part of the ship's general alarm system, it is to be capable of being sounded independently of the alarm to the passenger spaces.

18.2.6 The sound pressure levels are to be measured during a practical test and documented, see *Pt 6, Ch 2, 21.2 Trials*.

18.3 Public address system

18.3.1 Public address systems on passenger ships and cargo ships used to sound the general emergency alarm or the fire-alarm are to comply with SOLAS Ch III, Part B, *Section IV - Life-Saving Appliances and Arrangements Requirements* and *Section V - Miscellaneous*, the *LSA Code - International Life-Saving Appliance Code – Resolution MSC.48(66)*, *Code on Alerts and Indicators, 2009*, and the requirements of this Section.

18.3.2 The public address system is to be provided with an emergency source of electrical power in accordance with SOLAS Ch III, Part B, *Regulation 6 - Communications*, Section 5.4 with automatic changeover facilities located adjacent to the public address system. Failure of any power supply is to operate an audible and visual alarm, in accordance with LSA Code, *Chapter VII - Other Life-Saving Appliances and Code on Alerts and Indicators, 2009*, 4 General.

18.3.3 The public address system is to have multiple amplifiers having their power supplies so arranged that a single fault will not cause the loss of the facility to broadcast emergency announcements in public rooms, alleyways, stairways and control stations, albeit at a reduced capacity, for passenger vessels it is to be in accordance with *MSC/Circular.808 - Recommendation on Performance Standards for Public Address Systems on Passenger Ships, Including Cabling - (Adopted on 30 June 1997)*, Sections 2.5 - 2.7.

18.3.4 The public address distribution system is to be so arranged that a fire or casualty in any one main vertical zone, as defined by SOLAS 1974 as amended Reg II-2/A, *Regulation 3 - Definitions*, other than the zone in which the public address control station is located, will not interfere with the distribution in any other such zone.

18.3.5 There are to be at least two cable routes, sufficiently separated throughout their length, to public rooms, alleyways, stairways and control stations so arranged that any single electrical fault, fire or casualty will not cause the loss of the facility to broadcast emergency announcements in any public rooms, alleyways, stairways, and control stations, albeit at a reduced capacity. Refer to SOLAS *Chapter III - Life-saving appliances and arrangements*.

18.3.6 Amplifiers are to be continuously rated for the maximum power that they are required to deliver into the system for audio and, where alarms are to be sounded through the public address system, for tone signals.

18.3.7 Loudspeakers are to be continuously rated for their proportionate share of amplifier output and protected against short-circuits and passenger vessels are to be in compliance with *MSC/Circular.808 - Recommendation on Performance Standards for Public Address Systems on Passenger Ships, Including Cabling - (Adopted on 30 June 1997)*.

18.3.8 Amplifiers and loudspeakers are to be selected and arranged to prevent feedback and other interference. There are also to be means to automatically override any volume controls, so as to ensure the specified sound pressure levels are met. In addition the requirements of MSC Circular 808 for passenger vessels are required.

18.3.9 Where the public address system is used for sounding the general emergency alarm and the fire-alarm, the requirements as per *IMO Code on Alerts and Indicators, 2009*, 5 Audible Presentation of Alerts and Calls and 5 Audible Presentation of Alerts and Calls are to be met.

18.3.10 Where more than one alarm is to be sounded through the public address system, the requirements are in accordance with *Code on Alerts and Indicators, 2009* 5 Audible Presentation of Alerts and Calls.

18.3.11 The sound pressure levels are to be measured during a practical test using speech and, where applicable, tone signals, and documented, see *Pt 6, Ch 2, 21.2 Trials*.

18.4 Escape route or low location lighting (LLL)

18.4.1 The escape route or low location lighting (LLL) required by SOLAS 1974, as amended Pt D, Ch II-2, *Regulation 13 - Means of escape*, 3.2.5.1, where satisfied by electric illumination, is to comply with the requirements of this sub-Section. The positional marking of lighting or photo luminescent strip indicators is to be in accordance with SOLAS Ch II-2 Pt D, *Regulation 13 - Means of escape*, 3.2.5.1.

18.4.2 The LLL system is to be provided with an emergency source of electrical power as required by *Pt 6, Ch 2, 3.3 Emergency source of electrical power in passenger ships* and also be connected to the main source of electrical power, with automatic changeover facilities located adjacent to the control panel, see also *Pt 6, Ch 2, 1.16 Operation under fire conditions*.

18.4.3 The power supply arrangements to the LLL are to be arranged so that a single fault or a fire in any one fire zone or deck does not result in loss of the lighting in any other zone or deck. This requirement may be satisfied by the power supply circuit configuration, use of fire-resistant cables complying with *Pt 6, Ch 2, 11.5 Construction 11.5.3*, and/or the provision of suitably located power supply units having integral batteries adequately rated to supply the connected LLL for a minimum period of 60 minutes, see *Pt 6, Ch 2, 12.3 Location 12.3.8*. Manual activation is to be in accordance with *IMO Resolution A.752(18) - Guidelines for the Evaluation, Testing and Application of Low-Location Lighting on Passenger Ships - (Adopted on 4 November 1993)*.

18.4.4 For the recommendation of performance and installation of lights and lighting assemblies refer to ISO Standard 15370:2001 *Ships and marine technology - Low location lighting on passenger ships*.

■ Section 19 Ship safety systems

19.1 Watertight doors

19.1.1 Power operated sliding watertight doors including power supply, power supply availability, control, indication and alarm circuits are to comply with SOLAS Ch II-1, Regulation 13, *7 Additional requirements for ro-ro passenger ships*.

19.1.2 The enclosures of electrical components including their electric control cables are to be in compliance with SOLAS Ch II-1, Reg 13, *5 Means of escape on passenger ships from special category and open ro-ro spaces to which any passengers carried can have access*.

19.1.3 An audible alarm and where required supplemented by a visual signal at the door when the watertight doors are operated from remote is to be in accordance with SOLAS Ch II-1, Reg 13, *7 Additional requirements for ro-ro passenger ships*.

19.1.4 The requirement of sliding watertight doors on cargo ships is to comply with SOLAS Ch II-1, Regulation 13-1, *2 General requirements*.

19.1.5 For the necessity of a centralised operating console located on the navigation bridge on passenger vessels, it is to comply with SOLAS Ch II-1, , *Regulation 13 - Means of escape* Section 8.

19.2 Stern and side shell doors and bow and inner doors

19.2.1 The requirements of *Pt 6, Ch 2, 19.2 Stern and side shell doors and bow and inner doors 19.2.2 to Pt 6, Ch 2, 19.2 Stern and side shell doors and bow and inner doors 19.2.14* apply to all stern and side shell doors, bow doors and inner doors, giving access to vehicle decks, and subdivision doors, in accordance with *Pt 4, Ch 2, 9 Subdivision structure on vehicle deck*, on all ships except where otherwise stated in *Pt 6, Ch 2, 19.2 Stern and side shell doors and bow and inner doors 19.2.11* and *Pt 6, Ch 2, 19.2 Stern and side shell doors and bow and inner doors 19.2.12*.

19.2.2 A notice is to be displayed at the operating panel stating that the door is to be fully closed, secured and locked preferably before, or immediately the ship leaves the berth and that this operation is to be entered in the ship's log.

19.2.3 Control positions are to be provided with a system of warning indicator lights. The system is to provide positive indication that the door is fully closed, secured and locked. The indication arrangements are to be 'fail-safe' such that in the event of a fault the system cannot incorrectly indicate that the doors are fully closed, secured or locked.

19.2.4 The indication system is to be arranged such that it functions independently of any system for door operation, securing and locking.

19.2.5 The electrical power supply for the indication system is to be independent of any electrical power supply for operating, securing and locking the doors.

19.2.6 The indication system is to be fed from two exclusive circuits, one from the main source of electrical power and one from the emergency source of electrical power with automatic changeover facilities located adjacent to the panel. Loss of either active or standby power supply is to initiate an audible and visual alarm on the navigation bridge.

19.2.7 The indicator panel is to be provided with a lamp test function. It is not to be possible to turn off the indication lights at the panel. Dimming facilities may be provided, but the indications are to remain clearly readable under all operating lighting conditions.

19.2.8 Means are to be provided to prevent unauthorised operation of the doors and associated securing and locking devices.

19.2.9 Detection of door position and securing and locking device status is to be by direct sensing of proximity, contact or equivalent, not inferred from actuator positions. Sensors are to be protected against ice formation, mechanical damage and water ingress to be not less than IPX6 Standard as defined in IEC 60529: *Degrees of protection provided by enclosures (IP Code)*, or an acceptable and relevant National Standard.

19.2.10 Where a strongback or equivalent independent secondary means of securing an inwardly opening door is required, these need not be monitored by the indication system providing their correct positioning can be easily observed from the control position.

19.2.11 Doors with a clear opening area of 12 m² or greater are to be provided with closing devices operable from a remote control position. Doors which are located partly or totally below the freeboard deck with a clear opening area greater than 6 m² are

to be provided with an arrangement for remote control from a position above the freeboard deck. This remote control is to provide centralised control for:

- (a) The closing and opening of the doors.
- (b) Associated securing and locking devices.

19.2.12 Bow doors and inner doors, giving access to vehicle decks, and subdivision doors are to be provided with an arrangement for remote control from a position above the freeboard deck, providing centralised control for:

- (a) the closing and opening of the doors; and
- (b) associated securing and locking devices.

19.2.13 The location of the remote control panel is to be such that door operation can be easily observed by the operator or by other suitable means such as closed circuit television. Where remote control is required, television surveillance or other such means may satisfy this requirement.

19.2.14 A drainage system is to be arranged in the area between bow door and ramp or, where no ramp is fitted, between the bow door and inner door. The system is to be equipped with an audible alarm function on the navigation bridge being set off when the water levels in these areas exceed 0,5 m.

19.2.15 The additional requirements of *Pt 6, Ch 2, 19.2 Stern and side shell doors and bow and inner doors 19.2.16 to Pt 6, Ch 2, 19.2 Stern and side shell doors and bow and inner doors 19.2.22* apply to stern and side shell doors in the boundaries of special category spaces or ro-ro cargo spaces through which such spaces may be flooded, and to bow doors and inner doors. For cargo ships, where no part of the door is below the uppermost waterline and the area of the door opening is not greater than 6 m², the requirements of *Pt 6, Ch 2, 19.2 Stern and side shell doors and bow and inner doors 19.2.16 to Pt 6, Ch 2, 19.2 Stern and side shell doors and bow and inner doors 19.2.22* need not be applied.

19.2.16 An indicator panel is to be located on the navigating bridge, providing separate visual indications of the position of each door and the status of their associated securing/locking devices.

19.2.17 The indication system is to be provided with a 'harbour/sea voyage' mode selection function, with means of operation located on or adjacent to the navigating bridge indication panel. The selected mode is to be displayed on all indicator panels. An audible alarm is to be initiated on the navigating bridge if the ship leaves the harbour with any door not fully closed or not fully secured. Where practical, the alarm should be initiated immediately the ship leaves the berth. Audible alarms are to be silenced in the 'harbour' mode. Visual indications are to remain operational in either mode.

19.2.18 An audible and visual alarm is to be given on the navigation bridge in the event of any fault within the indication system.

19.2.19 An audible and visual alarm is to be initiated on the navigation bridge and the engine control room, or an equivalent attended position, in the event of leakage through the doors.

19.2.20 Television surveillance arrangements are to be provided to enable the positions of bow doors and inner doors, and a sufficient number of their closing devices, to be monitored from the navigation bridge and the engine control room, or an equivalent attended position. The television surveillance arrangements are also to allow leakage through the bow doors and inner doors to be assessed from the same positions in the event of leakage through the doors. Special consideration is to be given to the lighting and contrasting colour of objects under surveillance.

19.2.21 For passenger ships, television surveillance arrangements are to be provided to allow leakage through stern and side shell doors below the freeboard deck to be assessed from the navigation bridge and the engine control room, or equivalent attended position.

19.2.22 The electrical power supply for surveillance lighting is to be independent of any electrical power supply for operating, securing and locking the doors.

19.3 Subdivision doors on vehicle decks

19.3.1 Where subdivision doors are provided on passenger ship vehicle decks in accordance with *Pt 4, Ch 2, 9 Subdivision structure on vehicle deck*, the control and monitoring arrangements for these doors are to generally comply with *Pt 6, Ch 2, 19.2 Stern and side shell doors and bow and inner doors*.

19.4 Bilge pumps

19.4.1 Where the bilge pumps for the holds of open-top container ships are electrically driven one pump is to be supplied from the emergency switchboard, the remaining pumps are to be supplied from the main source of electrical power, independent of the emergency switchboard.

■ **Section 20**
Lightning conductors

20.1 General

20.1.1 In order to minimise the risks of damage to the ship and its electrical installation due to lightning, ships having non-metallic masts or topmasts are to be fitted with lightning conductors in accordance with the applicable requirements of IEC 60092-401: *Electrical installations in ships - Part 401: Installation and test of completed installation* or an alternative and relevant National Standard.

■ **Section 21**
Testing and trials

21.1 Testing

21.1.1 Tests in accordance with *Pt 6, Ch 2, 21.1 Testing 21.1.2* are to be satisfactorily carried out on all electrical equipment, complete or in sections, at the manufacturer's premises and a test report issued by the manufacturer.

21.1.2 A high voltage at any frequency between 25 and 100Hz is to be applied between:

- (a) all current carrying parts connected together and earth;
- (b) all current carrying parts of opposite polarity or phase.

For rotating machines the value of test voltage is to be 1000 V plus 2 x rated voltage with a minimum of 2000 V, and for other electrical equipment, it is to be in accordance with *Table 2.21.1 Test voltage*. Items of equipment included in the assembly for which a test voltage lower than the above is specified may be disconnected during the test and tested separately at the appropriate lower test voltage. The test is to be commenced at a voltage of about one-third the test voltage and is to be increased to full value as rapidly as is consistent with its value being indicated by the measuring instrument. The full test voltage is then to be maintained for 1 minute, and then reduced to one-third full value before switching off. The assembly is considered to have passed the test if no disruptive discharge occurs.

21.1.3 When it is desired to make additional high voltage tests on equipment which has already passed its tests, the voltage of such additional tests is to be 80 per cent of the test voltage the equipment has already passed.

Table 2.21.1 Test voltage

Rated voltage, U_n U_n V	Test voltage a.c. (r.m.s.), V
$U_n \leq 60$	500
$60 < U_n \leq 1000$	$2 \times U_n + 1000$
$1000 < U_n \leq 2500$	6500
$2500 < U_n \leq 3500$	10000
$3500 < U_n \leq 7200$	20000
$7200 < U_n \leq 12000$	28000
$12000 < U_n \leq 15000$	38000

21.1.4 Immediately after the high voltage test, the insulation resistance is to be measured using a direct current insulation tester, between:

- (a) all current-carrying parts connected together and earth;
- (b) all current-carrying parts of different polarity or phase.

The minimum values of test voltage and insulation resistance are given in *Table 2.21.2 Test voltage and minimum insulation*.

Table 2.21.2 Test voltage and minimum insulation

Rated voltage U_n V	Minimum voltage of the tests, V	Minimum insulation resistance, M Ω
$U_n \leq 250$	$2 \times U_n$	1
$250 < U_n \leq 1000$	500	1
$1000 < U_n \leq 7200$	1000	$\frac{U_n}{1000} + 1$
$7200 < U_n \leq 15000$	5000	$\frac{U_n}{1000} + 1$

21.1.5 Tests in accordance with the Standard with which the equipment complies may be accepted as an alternative to the above.

21.2 Trials

21.2.1 Before a new installation, or any alteration or addition to an existing installation, is put into service the applicable trials in *Pt 6, Ch 2, 21.2 Trials 21.2.2 to Pt 6, Ch 2, 21.2 Trials 21.2.7* are to be carried out. These trials are in addition to any acceptance tests which may have been carried out at the manufacturer's works and are to be to the Surveyor's satisfaction.

21.2.2 The insulation resistance is to be measured of all circuits and electrical equipment, using a direct current insulation tester, between:

- (a) all current-carrying parts connected together and earth and, so far as is reasonably practicable;
- (b) all current-carrying parts of different polarity or phase;

The minimum values of test voltage and insulation resistance are given in *Table 2.21.2 Test voltage and minimum insulation*. The installation may be subdivided and appliances may be disconnected if initial tests produce results less than these figures.

21.2.3 Tests are to be made to verify the effectiveness of:

- (a) earth continuity conductor;
- (b) the earthing of non-current-carrying exposed metal parts of electrical equipment and cables not exempted by *Pt 6, Ch 2, 1.12 Earthing of non-current carrying parts 1.12.2*;
- (c) bonding for the control of static electricity.

21.2.4 It is to be demonstrated that the Rules have been complied with in respect of:

- (a) satisfactory performance of each generator throughout a run at full rated load;
- (b) temperature of joint, connections, circuit-breakers and fuses;
- (c) the operation of engine governors, synchronising devices, overspeed trips, reverse-current, reverse-power and over-current trips and other safety devices;
- (d) voltage regulation of every generator when full rated load is suddenly thrown off and when starting the largest motor connected to the system;
- (e) voltage drop at the worst case condition;
- (f) harmonic distortion of the voltage waveform, where declared;
- (g) satisfactory parallel operation, and kW and KVA load sharing of all generators capable of being operated in parallel at all loads up to normal working load;
- (h) all essential and other important equipment are to be operated under service conditions, though not necessarily at full load or simultaneously, for a sufficient length of time to demonstrate that they are satisfactory;
- (i) propulsion equipment is to be tested under working conditions and operated in the presence of the Surveyors and to their satisfaction. The equipment is to have sufficient power for going astern to secure proper control of the ship in all normal circumstances. In passenger ships the ability of the machinery to reverse the direction of thrust of the propeller in sufficient time, under normal manoeuvring conditions, and so bring the ship to rest from maximum ahead service speed, is to be demonstrated at the sea trial; and

(j) operation of power management for electric propulsion.

21.2.5 Measurements are to be taken as part of the trials specified in *Pt 6, Ch 2, 21.2 Trials 21.2.4, Pt 6, Ch 2, 21.2 Trials 21.2.4, Pt 6, Ch 2, 21.2 Trials 21.2.4* and *Pt 6, Ch 2, 21.2 Trials 21.2.4* to verify that the installation will provide a quality of power supply in accordance with the values listed in *Pt 6, Ch 2, 1.8 Quality of power supplies*.

21.2.6 Satisfactory load management in accordance with *Pt 6, Ch 2, 6.9 Load management* is to be demonstrated. The demonstration is to include verification that the requirements of *Pt 6, Ch 2, 1.8 Quality of power supplies* will be met following disconnection of a generator under all defined operating profiles as agreed with the operators.

21.2.7 It is to be demonstrated by practical tests that the Rules have been complied with in respect of fire, crew and passenger emergency and ship safety systems.

21.2.8 On completion of the general emergency alarm system and the public address system tests, the Surveyor is to be provided with two copies of the test schedule, detailing the measured sound pressure levels. Such schedules are to be signed by the Surveyor and the Builder.

21.3 High voltage cables

21.3.1 Before a new high voltage cable installation, or an addition to an existing installation, is put into service a voltage withstand test is to be satisfactorily carried out on each completed cable and its accessories. The test is to be carried out after the insulation resistance test required by *Pt 6, Ch 2, 21.2 Trials 21.2.2* and may use either an a.c. voltage at power frequency or a d.c. voltage.

21.3.2 When an a.c. voltage withstand test is carried out, the voltage is to be not less than the normal operating voltage of the cable and it is to be maintained for a minimum of 24 hours.

21.3.3 When a d.c. voltage withstand test is carried out, the voltage is to be not less than:

- (a) $1,6 (2,5U_o + 2 \text{ kV})$ for cables of rated voltages (U_o) up to and including 3,6 kV, or
- (b) $4,2U_o$ for higher rated voltages

where U_o is the rated power frequency voltage between conductor and earth or metallic screen, for which the cable is designed.

The test voltage is to be maintained for a minimum of 15 minutes. After completion of the test the conductors are to be connected to earth for a sufficient period in order to remove any trapped electrical charge. An insulation resistance test in accordance with *Pt 6, Ch 2, 21.2 Trials 21.2.2* is then to be repeated.

21.4 Hazardous areas

21.4.1 All electric equipment located in hazardous areas is to be examined to ensure that it is of a type permitted by the Rules, has been installed in compliance with its certification, and that the integrity of the protection concept has not been impaired.

21.4.2 Alarms and interlocks associated with pressurised equipment and the ventilation of spaces located in hazardous areas are to be tested for correct operation.

■ *Section 22* **Spare gear**

22.1 General

22.1.1 It is recommended that adequate spares, together with the tools necessary for maintenance, or repair, be carried. The spares are to be determined by the Owner according to the design and intended service. The maintenance of the spares is the responsibility of the Owner.

■ Section 23**Ergonomic Lighting Design – ELD optional notation****23.1 Objectives**

23.1.1 The requirements in this Section are applicable where the optional class notation for ergonomic lighting design is requested.

23.1.2 The design and installation of indoor lighting is to facilitate visual task performance, safety and visual comfort. In order to achieve this goal the requirements of *Pt 6, Ch 2, 23.2 Positioning and installation to Pt 6, Ch 2, 23.6 Night vision* are to be complied with.

23.1.3 The requirements in this Section do not address emergency or navigational lighting.

23.2 Positioning and installation

23.2.1 In order to meet the ergonomic requirements of *Pt 6, Ch 2, 23.2 Positioning and installation to Pt 6, Ch 2, 23.6 Night vision* the positioning and installation of lights is to comply with *Pt 6, Ch 2, 23.2 Positioning and installation 23.2.2 to Pt 6, Ch 2, 23.2 Positioning and installation 23.2.11*.

23.2.2 Natural lighting through the use of windows and doors is to be provided as far as practicable.

23.2.3 Lights are to be positioned, as far as practicable, in the same horizontal plane and arranged symmetrically to produce a uniform level of illumination.

23.2.4 Lights are to be positioned so as to reduce bright spots and shadows as far as possible.

23.2.5 Lights are to be positioned taking account of structures such as beams and columns etc. so the lighting is not blocked by these items.

23.2.6 Lights are not to be positioned in locations which would result in limited illumination.

23.2.7 Lights are to be positioned taking account of air-conditioning vents or fans, fire detectors, water sprinklers etc. so the lighting is not blocked by these items.

23.2.8 The position of lights configured to strips or tubes is, as far as practicable, to be at right angles to an operator's line of sight while the operator is located at their typical duty station.

23.2.9 Any physical hazards that provide a risk to operator safety are to be appropriately illuminated.

23.2.10 The positioning of lights is to consider the transfer of heat to adjacent surfaces.

23.2.11 Lights are to be positioned in locations that are easy to reach for lamp replacement or maintenance.

23.3 Luminance distribution

23.3.1 In order to provide even, fatigue-free illumination the requirements of *Pt 6, Ch 2, 23.3 Luminance distribution 23.3.2 to Pt 6, Ch 2, 23.3 Luminance distribution 23.3.6* are to be complied with.

23.3.2 The light levels falling on the plane in which a task is performed are to be suitable for the type of task, i.e. they are to consider the variation in the working planes.

23.3.3 Sharp contrasts in illumination levels across an operator task or working plane are to be avoided, as far as possible.

23.3.4 Sharp contrasts in illumination levels between an operator task area and the immediate surround and general background area are to be avoided, as far as possible.

23.3.5 Where required, local lighting for operational tasks is to be provided in addition to general lighting.

23.3.6 Lighting is to be free of perceived flicker.

23.4 Glare

23.4.1 In order to minimise glare (to avoid dazzle, discomfort and fatigue) the requirements of *Pt 6, Ch 2, 23.4 Glare 23.4.2 to Pt 6, Ch 2, 23.4 Glare 23.4.6* are to be complied with.

23.4.2 Lights are to be positioned so as to reduce, as far as possible, glare or high brightness reflections from working and display surfaces.

23.4.3 Lights are to be positioned so as to provide even illumination and minimal glare on controls, displays and indicators.

23.4.4 Where necessary, suitable blinds and shading devices are to be used to prevent glare.

23.4.5 Surfaces are to have a non-reflective or matt finish in order to reduce the likelihood of indirect glare.

23.4.6 Where a transparent cover is fitted over a control, display or indicator, it is to be designed to minimise reflections.

23.5 Location of lighting controls and outlets

23.5.1 In order to allow convenient use of lighting the requirements of *Pt 6, Ch 2, 23.5 Location of lighting controls and outlets 23.5.2 to Pt 6, Ch 2, 23.5 Location of lighting controls and outlets 23.5.2* are to be complied with.

23.5.2 The lighting system is to be easily maintained and operated by personnel.

23.5.3 Lighting is to be controllable locally in accommodation and working areas, except where this conflicts with safety requirements.

23.5.4 Light switches are to be fitted in safe positions for personnel.

23.5.5 The mounting height of switches is to be such that personnel can reach switches with ease.

23.5.6 Power outlets are to be provided where temporary, local, task lighting will be required, except in hazardous areas.

23.6 Night vision

23.6.1 In order to maintain night vision and facilitate safety during hours of darkness the requirements of *Pt 6, Ch 2, 23.6 Night vision 23.6.2 to Pt 6, Ch 2, 23.6 Night vision 23.6.4* are to be complied with.

23.6.2 Lighting on the ship's superstructure is to be directed away from, and shaded to prevent direct illumination of, the bridge windows and lookout points.

23.6.3 Instrument lighting is to be such that the operator can read dials and indicators without impediment of night vision.

23.6.4 Lighting of instruments, keyboards and controls is to be adjustable down to zero, except for the lighting of alarm and warning indicators and the controls of dimmers, which are to remain readable.

Section

- 1 **General requirements**
- 2 **Design criteria**
- 3 **Refrigerating machinery and refrigerant storage compartments**
- 4 **Refrigeration plant, pipes, valves and fittings**
- 5 **Refrigerant detection systems**
- 6 **Electrical installation**
- 7 **Instrumentation, control, alarm, safety and monitoring systems**
- 8 **Personnel safety equipment and systems**
- 9 **Refrigerated cargo spaces**
- 10 **Container ships fitted with refrigerating plant to supply cooled air to insulated containers in holds**
- 11 **Acceptance trials**

■ *Section 1* **General requirements**

1.1 Application

1.1.1 The requirements of this Chapter apply to the refrigerated cargo installations of refrigerated cargo ships, refrigerated container ships, fish factory ships, fishing vessels, fruit juice carriers, and the reliquefaction/refrigerating plant of liquefied gas carriers and chemical carriers or tankers, where an **RMC** notation is requested.

1.1.2 Ships with refrigerated cargo installations which are approved, installed and tested in accordance with these requirements will be eligible for the applicable class notation specified in *Pt 1, Ch 2 Classification Regulations*.

1.1.3 The requirements for the classification of ships for the carriage of liquefied gas are given in Lloyd's Register's (hereinafter referred to as 'LR') *18 Rules and Regulations for the Construction and Classification of Ships for the Carriage of Liquefied Gases in Bulk, July 2015* (hereinafter referred to as the Rules for Ships for Liquefied Gases). Where reliquefaction or refrigeration equipment is fitted for cargo temperature and pressure control, the equipment is to comply with the requirements of *Pt 6, Ch 3, 2 Design criteria to Pt 6, Ch 3, 11 Acceptance trials*, as applicable.

1.1.4 The requirements for the refrigeration equipment and systems necessary for provision stores and air conditioning are specified in *Pt 7, Ch 15 Refrigeration Systems and Equipment Serving Provision Stores and Air-Conditioning Installations*.

1.2 Plans and particulars

1.2.1 The following plans and particulars, as applicable, and any others which may be specially requested for the **refrigerating plant and systems**, are to be submitted in triplicate for approval, before construction is commenced:

- (a) Schematic plans, including full particulars of piping and instrumentations, for:
 - primary and secondary refrigeration systems;
 - air cooler defrosting arrangements;
 - gas reliquefaction systems; and
 - condenser cooling water systems.
- (b) Detailed dimensioned plans and material specifications for:
 - reciprocating compressor crankshaft and crankcase, where exposed to refrigerant pressure;
 - rotary-type compressor rotors and casing;
 - condensers shell and tube and plate type;

- evaporators shell and tube and plate type;
 - air coolers;
 - arrangement of air cooling pipe grids and construction method;
 - liquid receivers;
 - oil separators; and
 - any other pressure vessels, *see Pt 5, Ch 11, 1.6 Plans 1.6.1.*
- (c) General arrangement of refrigerating machinery compartment in elevation and plan, showing location and arrangement of the plant, ventilation details and location of temperature sensors and vapour detectors.
- (d) Details of automatic controls, alarms and safety systems, *see Pt 6, Ch 3, 1.1 Application.*
- (e) Details of level indicators.
- (f) Where provision is made for the manufacture and/or storage of inert gas in liquid form, details of the storage vessel insulation arrangements and the reliquefaction equipment and piping system are to be submitted.
- (g) Capacity calculations for pressure relief valves and/or bursting discs, and discharge pipe pressure drop calculations, *see Pt 6, Ch 3, 4.15 Overpressure protection devices 4.15.5 to Pt 6, Ch 3, 4.15 Overpressure protection devices 4.15.21.*
- (h) Programme of tests to be conducted on completion of the installation, *see Pt 6, Ch 3, 11 Acceptance trials.*

1.2.2 The following plans and particulars, as applicable, and any others which may be specially requested for **refrigerated cargo spaces**, are to be submitted in triplicate for approval, before work is commenced:

- (a) Specification of proposed insulation envelope system, including physical, thermal and fire properties.
- (b) General arrangement of insulated refrigerated spaces in elevation and plan.
- The plans are to be to a scale adequate for the measurement of the external surfaces and the deck and bulkhead edges.
 - Dimensions and spacing of frames, beams and stiffeners, and details of other steel work intruding into the insulation and within the spaces, are to be shown.
 - Fuel oil and liquid cargo tanks adjacent to or below the refrigerated spaces are to be shown, and whether heating arrangements are provided for such tanks are to be indicated.
 - Ventilating and air-conditioning trunks, and ducts passing through refrigerated spaces are to be shown.
 - The plans are to include a diagram showing the position of the spaces in relation to other parts of the ship if this is not otherwise apparent.
- (c) Plans showing:
- the thicknesses and methods of attachment of the insulation and linings on all surfaces including girders, hatch coamings and pillars; and
 - details of prefabricated panels and their fixings, vapour barriers, insulated doors and hatch access, bilge and manhole plugs and their frames.
- (d) Methods of attachment of air cooling grids (if fitted) are to be indicated.
- (e) Size and position of refrigerated space pressure equalising devices, where fitted, *see Pt 6, Ch 3, 9.2 Insulation systems 9.2.12 and Pt 6, Ch 3, 9.2 Insulation systems 9.2.13.*
- (f) Arrangements of the drainage system, and sounding and air pipes that pass through the refrigerated spaces.
- (g) Arrangements of air ducts and distribution systems within the refrigerated spaces (including method of cooling spaces within hatch coamings), and air cooler spaces showing location of the coolers and their fans and drive motors.
- (h) Details of temperature indicating, and recording and sensing equipment, and arrangement of sensors within the refrigerated spaces.

1.2.3 Single copies of the following plans and particulars are to be submitted:

- LR Data Sheet for refrigerated cargo installations (LR Form 3905).
- Specification of proposed refrigerating system and auxiliary equipment, including the refrigerating capacities of the compressors, condensers, evaporators and air coolers.
- Heat load calculations at all design operating conditions justifying the refrigerating capacity which is to be installed.

1.3 Materials

1.3.1 Steel plating used in ship construction is to be of an appropriate grade corresponding to the proposed temperature notation, *see Pt 3, Ch 2, 2.2 Refrigerated spaces.*

1.3.2 Materials used in the construction of the refrigerating equipment and associated systems are to be generally manufactured and tested in accordance with the requirements of the *Rules for the Manufacture, Testing and Certification of Materials, July 2015* (hereinafter referred to as the Rules for Materials).

1.3.3 Where it is proposed to use materials other than those specified in the Rules for Materials, details of the chemical compositions, heat treatment and mechanical properties are to be submitted for approval. In such cases the values of the mechanical properties used for deriving the allowable stress are to be subject to agreement with LR.

1.3.4 All materials used in refrigerating equipment and systems are to be suitable for use with the selected refrigerants. This includes joints, sealing materials and lubricants. For example, the following materials and refrigerants are not to be combined:

- Copper with ammonia.
- Magnesium with fluorinated hydrocarbons.
- Zinc with ammonia or fluorinated hydrocarbons.

1.3.5 For ammonia systems, the condensers/evaporators are to be manufactured in titanium or a suitable grade of stainless steel.

1.4 Equipment to be constructed under survey

1.4.1 All major items of equipment are to be surveyed at the manufacturer's works. The workmanship is to be to the Surveyor's satisfaction and the Surveyor is to be satisfied that the components are suitable for the intended purpose and duty. Examples of such units are:

- Crankshafts, crankcases, rotor shafts and casings for all compressors.
- Condensers.
- Evaporators (secondary refrigerant coolers).
- Air coolers.
- Pressure vessels (e.g. liquid receivers, surge drums, suction separators, intercoolers, oil separators).
- Cooling water pumps for condensers.
- Valves and other components intended for installation in pressure piping systems having a maximum working pressure greater than 7 bar.
- Thermal insulating panels (factory made).

1.5 Type approved equipment

1.5.1 Where it is proposed to use components (e.g. compressors, condensers, oil separators) which have valid LR Type Approval or General Approval Certificates, the types and model numbers of the components are to be stated. Plans of components that have been so approved need not be re-submitted.

1.6 Notation and temperature conditions

1.6.1 The class notation assigned will state the minimum temperature or a temperature range approved by the Committee for the installation with the maximum sea temperature stated, e.g. `✱ Lloyd's RMC to maintain temperature(s) of minus 29°C to plus 14°C with sea temperature plus 32°C maximum'.

1.6.2 For refrigerated installations aboard container ships with approved refrigerating plant and arrangements to supply refrigerated air through ducting to insulated containers, the class notation assigned will additionally specify the maximum number and characteristics of the containers for which the plant is approved, e.g. `to supply refrigerated air at temperatures of minus 25°C to plus 14°C to 800 certified insulated containers with an average thermal transmittance per container of 27 W/K with sea temperature plus 32°C maximum'.

1.6.3 For reliquefaction or refrigerating plants aboard liquefied gas carriers, the notation assigned will state the minimum cargo temperature for which the installation is approved, unless otherwise qualified, see *LR III.3 Class notation (refrigerated installations)* of the Rules for Ships for Liquefied Gases.

1.6.4 On application from an Owner, consideration will be given by the Committee to an alternative temperature notation being assigned to that appearing in the *Register Book*.

1.7 Novel arrangements and design

1.7.1 Where the proposed construction of the refrigerating plant or refrigerated spaces or chambers is novel in design or involves the use of unusual material, special tests may be required, and a suitable class notation may be assigned when the Committee considers this necessary.

1.8 Heat balance tests

1.8.1 A heat balance test will be required as prescribed in *Pt 6, Ch 3, 11 Acceptance trials* on a classed installation, or one being considered for reclassification, when extensive repairs or alterations have been carried out, or when the Surveyors consider that an amended temperature condition should be assigned.

1.9 Controlled atmosphere (CA) systems

1.9.1 Where it is intended to install a CA system on a vessel intended for classification, the requirements of *Pt 7, Ch 1 Controlled Atmosphere Systems* are to be complied with.

1.9.2 Where a **CA** notation is requested by an Owner, it is a prerequisite that the refrigeration installation be assigned an **RMC** notation.

1.10 Spare gear and refrigerant charge

1.10.1 It is recommended that adequate spares, together with the tools necessary for maintenance, or repair, be carried. The spares are to be determined by the Owner according to the design and intended service. The maintenance of the spares is the responsibility of the Owner.

1.10.2 For systems complying with *Pt 6, Ch 3, 2.5 Design pressures 2.5.6* sufficient carbon dioxide is to be carried on board to allow the refrigeration system to be fully recharged. In addition, adequate reserve supplies of refrigerant are to be carried for maintenance purposes. The replacement refrigerant is to be stored in containers complying with *Pt 6, Ch 3, 3.3 Gas storage compartments 3.3.5*.

■ Section 2 Design criteria

2.1 General

2.1.1 The proposed refrigerating plant, insulation and refrigerants are to be suitable for achieving the designed notation temperature. The refrigerating machinery and all components are to operate satisfactorily under the conditions listed in *Table 1.3.1 Ambient operating conditions in Pt 5, Ch 1 General Requirements for the Design and Construction of Machinery*.

2.1.2 The properties of steel materials used in refrigerated holds are to be suitable for the proposed notation temperature.

2.2 Refrigerants and classes of pipes

2.2.1 These Rules are applicable to the primary refrigerants in *Table 3.2.1 Primary refrigerants and their class of pipe*.

2.2.2 Attention is to be given to any statutory requirements, regarding the use of refrigerants, of the National Authority of the country in which the ship is to be registered.

Table 3.2.1 Primary refrigerants and their class of pipe

Refrigerant	Type	Composition	Class of Pipe		
			Class I	Class II	Class III
R-717 (Ammonia)	NH ₃	-	X	-	-
R-22	HCFC	-	-	X	-
R-290 (Propane)	HC	-	-	X	-

R-600a (Isobutane)	HC	-	-	X	-
R-134a	HFC	-	-	-	X
R-407C	Blend	R-32, R-125, R-134a	-	X	-
R-410A	Blend	R-32, R-125	-	X	-
R-507A	Blend	R-125, R-143a	-	X	-
R-404A	Blend	R-134a, R-125, R-143a	-	X	-
R-744 (Carbon Dioxide)	CO ₂	-	See Pt 6, Ch 3, 2.5 Design pressures 2.5.6		
<p>Note 1. HCFC - Hydrochlorofluorocarbon.</p> <p>Note 2. HFC - Hydrofluorocarbons.</p> <p>Note 3. HC – Hydrocarbon.</p> <p>Note 4. In view of increasing world-wide restrictive legislation and phasing out of the refrigerants R-22, it is recommended that this refrigerant should not be used in any new installation.</p> <p>Note 5. Although ozone depleting and global warming potentials are not included in these Rules for Classification, these effects are important and need to be considered when selecting the refrigerant for a particular application.</p>					

2.2.3 Within the parameters of pressures, temperatures, toxic nature and flammability, the class of pipe to be used with various refrigerants is shown in *Table 3.2.1 Primary refrigerants and their class of pipe*.

2.2.4 Design conditions as applicable to the classes of pipes are defined in *Pt 5, Ch 12, 1.5 Design temperature*.

2.2.5 The materials of Class I and Class II piping systems are to be manufactured at a works approved by LR and tested in accordance with the appropriate requirements of Rules for Materials. Particular attention is drawn to *Ch 6, 4 Ferritic steel pressure pipes for low temperature service*, of the Rules for Materials, where testing requirements for pipes used for low temperature service are given.

2.2.6 The materials of Class III piping system are to be manufactured and tested in accordance with the requirements of acceptable National Specifications. The manufacturer's test certificate will be acceptable and is to be provided for each consignment of materials.

2.2.7 Particulars of refrigerating systems using refrigerants other than those listed will be given special consideration.

2.3 Refrigeration units

2.3.1 A refrigerating unit is considered to comprise a compressor, its driving motor and one condenser. Where a secondary refrigerant, such as brine, is employed, the unit is also to include an evaporator (secondary refrigerant cooler) and a brine pump.

2.3.2 Two or more compressors driven by a single motor, or having only one condenser or evaporator (secondary refrigerant cooler) are to be regarded as one unit.

2.3.3 The refrigerating units of a classed cargo installation are to be completely independent of any refrigerating machinery associated with air-conditioning plant, or any domestic refrigerated installation, or any process plant, unless full details of any proposal have been submitted and approved.

2.4 Refrigeration capacity

2.4.1 The refrigeration capacity provided is to be sufficient to maintain the temperatures specified in the class notation when operating 24 hours per day with one unit on standby. The plant is to be able to cool down a complete cargo to its carrying temperature within the time specified by the manufacturer. The standby unit may be considered as an operating unit during the cooling down period of a non-precooled cargo. In order to compensate for deterioration of machinery and insulation over the life of the installation, the equipment is to be designed to have at least five per cent excess capacity over that required for maximum design output.

2.4.2 The proposals of both machinery and insulating contractors will be evaluated by LR in determining the theoretical capabilities of the equipment to maintain the duty temperatures. LR will advise the contractors after appraisal of the specification and plans if it is considered that additional refrigeration or insulating effect is required, but the temperature assigned on completion of the capacity heat balance test will be determined from the actual results of the test.

2.4.3 Where the units are not connected in common to all refrigerated chambers, the equipment serving each group of chambers is to comply with *Pt 6, Ch 3, 2.4 Refrigeration capacity 2.4.1*.

2.4.4 In the case of installations having a large number of small units arranged to serve individual chambers or groups of chambers, the question of standby capacity will be specially considered.

2.4.5 Where only two refrigerating units are fitted, the working parts are to be interchangeable.

2.4.6 Where a refrigerating plant is provided for sub-cooling the liquid refrigerant of other units, but is not arranged for cooling the cargo chambers independently, it will not be regarded as a unit.

2.5 Design pressures

2.5.1 The design pressure of the system will be regarded as equal to its maximum working pressure.

2.5.2 The maximum working pressure is the maximum permissible pressure within the system (or part system) in operation or at rest. No relief valve is to be set to a pressure higher than the maximum working pressure.

2.5.3 The design pressure of the low pressure side of the system is to be the saturated vapour pressure of the refrigerant at plus 46°C. Due regard is to be taken of defrosting arrangements which may cause a higher pressure to be imposed on the low pressure system.

2.5.4 The minimum design pressure of the high pressure side of the system (P_{dh}), is to be $1,11 \times P_b$, where P_b is an allowance for the compressor high pressure cut-out. P_b is to be at least equal to $1,11 \times P_a$, where P_a is the condenser working pressure, when operating in tropical zones and equates to the saturation pressure at 46°C.

2.5.5 Design pressures (bar g) applicable to refrigerants are to be not less than the values given in *Table 3.2.2 Pressure limits* when condensers are sea-water cooled. The design pressure for other refrigerants and condensing arrangements is to be agreed with LR.

2.5.6 Due to the low critical temperature of carbon dioxide it is inappropriate to determine the design pressure in accordance with *Pt 6, Ch 3, 2.5 Design pressures 2.5.3*. The proposed design pressure for a carbon dioxide system is to be stated, taking account of the maximum working pressure and the maximum pressure at rest conditions. Where the maximum pressure at rest condition is maintained by the fitting of a supplementary refrigeration unit, condensing the vapour in a holding vessel, supporting calculation is to be provided to show that this can be undertaken with a local ambient temperature of 45°C. The holding vessel is to be thermally insulated to prevent the operation of the relief devices within a 24 hour period after stopping the supplementary refrigeration unit at an ambient temperature of 45°C and an initial pressure equal to the starting pressure of the refrigeration unit. *Pt 6, Ch 3, 2.5 Design pressures 2.5.7*

2.5.7 Where a carbon dioxide system is designed for hot gas defrosting, due regard is to be given to the possibility of a higher pressure being imposed on the low pressure system. The design pressure for this section of the system shall be 10 per cent above the maximum pressure experienced during defrosting.

Table 3.2.2 Pressure limits

Refrigerant	Pressure (bar g)	
	High	Low
R-717	21,2	17,2
R-22	20,6	16,7
R-290	18,1	14,7
R-600a	6,4	5,2
R-134a	13,4	10,9
R-407C	23,5	19,0
R-410A	33,14	29,9
R-507A	25,3	20,5

R-404A	24,8	20,1
R-744	See Pt 6, Ch 3, 2.5 Design pressures 2.5.6	

2.6 Insulation

2.6.1 Properties of materials used for thermal insulation are to be verified against known standards for the following parameters, as applicable, to ensure that they are adequate for the intended service. The test results are to be made available to LR for approval:

- Closed cell content.
- Density.
- Mechanical properties.
- Thermal expansion.
- Abrasion.
- Cohesion.
- Thermal conductivity.
- Resistance to fire and flame spread.
- Ageing.
- Bonding (adhesive and cohesive strength).

2.6.2 Where the *in situ* foam type of insulation is proposed, full details of the process are to be submitted for approval.

2.6.3 Where applicable, having regard to their location and environmental conditions, insulation materials are to be:

- suitably resistant to fire;
- suitably resistant to the spreading of flame;
- adequately protected against penetration of water vapour; and
- adequately protected against mechanical damage.

■ Section 3 Refrigerating machinery and refrigerant storage compartments

3.1 General

3.1.1 Refrigerating machinery is to be located in a well ventilated compartment. In general, the arrangements are to be such that all components of the refrigerating machinery can be readily opened up for inspection or replacement. Space is to be provided for the withdrawal and renewal of the tubes in 'shell-and-tube' type evaporators (brine coolers) and condensers. Proposals for alternative arrangements are to be submitted for consideration. See Pt 6, Ch 3, 3.2 Arrangements for compartments housing machinery using ammonia for refrigerating machinery using ammonia.

3.1.2 Refrigerating machinery using toxic and/or flammable refrigerants is to be located outside the main machinery space in a separate gastight compartment.

3.1.3 Where the refrigerating machinery is located in a separate gastight compartment, outside the main machinery space, this compartment is to be equipped with effective mechanical ventilation to provide 30 air changes per hour based upon the total volume of the space. The mechanical ventilation is to have two main controls, one of which is to be operable from a place outside the compartment.

3.1.4 Refrigerating machinery using non-toxic and non-flammable refrigerants will not, in general, be required to be located in a separate compartment outside the main machinery space.

3.1.5 Openings for pipes, electrical cables and other fittings in the bulkheads and deck are to be fitted with gastight seals.

3.1.6 Ammonia piping is not to pass through accommodation spaces.

3.2 Arrangements for compartments housing machinery using ammonia

3.2.1 Where ammonia refrigerant is used, the refrigerating machinery shall be installed in a dedicated gastight compartment. See also Pt 6, Ch 3, 3.2 Arrangements for compartments housing machinery using ammonia 3.2.9.

3.2.2 The compartment containing ammonia refrigerating machinery and any access ways are to be provided with independent mechanical ventilation capable of:

- removing the heat generated by the equipment installed in the compartment;
- maintaining the atmosphere in the compartment at acceptable vapour threshold levels under normal operating conditions; and
- disposing of ammonia vapour safely and quickly in the event of a major leakage.

3.2.3 The ventilation system is to be of the negative pressure type where abnormal stoppages of the extraction fans activate an audible and visual alarm.

3.2.4 Compartments containing ammonia refrigerating machinery, including process vessels, are to be provided with:

- a negative ventilation system, independent of ventilation systems serving other spaces, having a capacity of not less than 30 air changes per hour based upon the total volume of the space. Other suitable arrangements which ensure an equivalent effectiveness may be considered;
- fresh air inlets, located at a low level in the machinery compartment and arranged so as to provide a supply of fresh air and to minimise the possibility of re-cycling the exhaust air from the outlet;
- exhaust outlets, located at a high level and arranged so as to promote good air distribution throughout the compartment;
- a fixed ammonia detector system with alarms inside and outside the compartment;
- water screens above all access doors, operable manually from outside the compartment in all ambient conditions;
- an independent bilge system;
- where the charge is greater than 50 kg, emergency body shower and eye wash facilities shall be installed locally outside the compartment. The water for the shower is to be thermostatically controlled so as to avoid low temperature shock.

3.2.5 Compartments are to have at least two access doors, opening outwards, one of which is to be an emergency exit giving direct access to the open deck. The doors are to be fitted with an easily operated opening mechanism to facilitate rapid escape in an emergency. In the case of small compartments where more than one door would be impractical, the emergency exit only is to be provided.

3.2.6 At least two sets of self-contained breathing apparatus and protective clothing are to be provided, readily available in the vicinity of the compartment but external to the area of risk. See Pt 6, Ch 3, 8.1 Personnel safety equipment 8.1.4.

3.2.7 The location of the exhaust duct, from the compartment or area, is to be free from obstruction and be such as not to cause danger. Where practicable, they are to be 10 m, where practicable, in the horizontal direction from other ventilation intakes and openings to accommodation and other enclosed areas, and at least 2 m above the surrounding deck.

3.2.8 Ventilation fans are not to produce a source of vapour ignition in either the ventilated compartment/area or ventilation system. Ventilation fans and fan ducts, in way of fans only, are to be of non-sparking construction.

3.2.9 In the case of ammonia plants on fishing ships under 55 m overall length, or ammonia plants with a charge of ammonia not greater than 25 kg, the refrigerating machinery may be located in the main machinery space provided it complies with the following requirements:

- The entrance to the machinery space is properly illuminated and marked and has warning signs permanently posted.
- The area where the ammonia machinery is installed is served by a hood with a negative ventilation system, so as not to permit any leakage of ammonia dissipating into other areas.
- A water spray system is provided for the area.
- Coamings, of not less than 150 mm in height, are installed around the ammonia machinery area.
- A fixed ammonia detector system with alarms inside and outside the main machinery space is provided.
- Means are provided for stopping the ammonia compressor prime movers from a position outside the machinery space.
- At least two sets of self-contained breathing apparatus and protective clothing are to be provided readily available in the vicinity of the compartment but external to the area of risk. See Pt 6, Ch 3, 8.1 Personnel safety equipment 8.1.4.
- Air intakes of other machinery are located away from the ammonia machinery area as far as is practicable.

3.3 Gas storage compartments

3.3.1 Portable steel cylinders containing reserve supplies of refrigerant are to be stored in a well ventilated compartment reserved solely for this purpose.

3.3.2 The compartment is to be provided with a mechanical ventilation system providing 10 air changes per hour and is to have at least one door opening outwards giving direct access to open deck.

3.3.3 Bulk storage tanks holding more than 150 kg of replacement carbon dioxide are to be located in a separate compartment. The compartment is to be provided with a mechanical ventilation system having a minimum capacity of 6 air changes per hour. The ventilation system exhaust ducting is to remove air from the base of the compartment. The compartment is to be fitted with a gas tight access door opening outward.

3.3.4 The compartment is to be provided with a refrigerant vapour detection system.

3.3.5 The compartment is to be provided with suitable water drainage arrangements not connected with the main machinery spaces.

3.3.6 Steel storage cylinders are to be of an approved type, supplied by the refrigerant manufacturer and are to be filled to a level suitable for an ambient temperature of plus 46°C.

3.3.7 The compartment is to be provided with racks to facilitate secure stowage of the cylinders.

3.4 Compartments housing carbon dioxide containing equipment

3.4.1 Self closing gas tight access doors are to be provided between each compartment and the dedicated escape routes. See Pt 6, Ch 3, 5.1 General 5.1.5.

3.4.2 In compartments which are normally occupied and where the volume of ventilation required by Pt 6, Ch 3, 3.1 General 3.1.3 is not desirable, such as production areas on fishing vessels, a negative pressure ventilation system, capable of 10 air changes per hour, is required to be fitted. This ventilation system is to be automatically activated when, in the event of a leak the concentration of carbon dioxide reaches a predetermined level but in no case higher than the threshold limit value of 5,000 ppm.

■ Section 4**Refrigeration plant, pipes, valves and fittings****4.1 General requirements for refrigerating compressors**

4.1.1 New compressor types or developments of existing types are to be subjected to an agreed programme of type testing to complement the design appraisal and review of documentation.

4.1.2 Where it is proposed to treat the bearing surfaces either by local hardening or by chromium plating, then these processes are to be confined to the bearing area and not extended to the fillets. Particulars of the process are to be submitted.

4.1.3 Where ball or roller bearings are incorporated, they are to have a minimum life expectancy of 25 000 running hours, for the application in question.

4.1.4 A check valve is to be fitted to each compressor discharge.

4.1.5 Where off-loading devices are incorporated, arrangements are to be provided which indicate the extent of the off-loading being effected.

4.1.6 A pressure relief valve and/or safety disc is to be fitted between each compressor and its gas delivery stop valve in accordance with Pt 6, Ch 3, 4.15 Overpressure protection devices 4.15.5 and Pt 6, Ch 3, 4.15 Overpressure protection devices 4.15.6.

4.1.7 Stop valves are to be provided on compressor suctions and discharges.

4.1.8 Suction strainers and lubricating oil filters are to be provided and so arranged that they are easily accessible for cleaning or renewal of the filter elements, without substantial loss of refrigerant or lubricating oil.

4.1.9 The correct direction of rotation is to be permanently indicated.

4.1.10 Where any hermetic or semi-hermetic compressor has the electric motor cooled by the circulating refrigerant, the following arrangements are to be provided:

- (a) Refrigeration circuits are to contain no more than one hermetic or semi-hermetic compressor.
- (b) Every compressor motor is to be fitted with a thermal cut-out device to protect the motor against overheating.
- (c) In each refrigeration circuit containing a hermetic or semi-hermetic compressor, suitable arrangements shall be provided to remove debris and contaminants resulting from a motor failure. See Pt 6, Ch 3, 4.16 Filters, driers and moisture indicators 4.16.1.
- (d) The pressure envelope of any hermetic or semi-hermetic compressor exposed to the refrigerant pressure is to be designed and constructed in accordance with the requirements of Pt 5, Ch 11 and Ch 17 as applicable. Plans are to be submitted for consideration as required by Pt 5, Ch Pt 5, Ch 11, 1.6 Plans.

4.2 Reciprocating compressors

4.2.1 The specified minimum tensile strength of castings and forgings for crankshafts is to be selected within the following general limits:

- (a) Carbon and carbon-manganese steel castings -
400 to 550 N/mm².
- (b) Carbon and carbon-manganese steel forgings (normalised and tempered) -
400 to 600 N/mm².
- (c) Carbon and carbon-manganese steel forgings (quenched and tempered) -
not exceeding 700 N/mm².
- (d) Alloy steel castings -
not exceeding 700 N/mm².
- (e) Alloy steel forgings -
not exceeding 1000 N/mm².
- (f) Spheroidal or nodular graphite iron castings -
370 to 800 N/mm².
- (g) Grey iron castings -
not less than 300 N/mm².

4.2.2 Where it is proposed to use materials outside the ranges specified in Pt 6, Ch 3, 4.2 Reciprocating compressors 4.2.1, details of the chemical composition, heat treatment and mechanical properties are to be submitted for approval.

4.2.3 Materials for components of reciprocating compressors such as crankshafts, pistons, piston rods, crank cases, etc. are to be produced at a works approved by LR and in general to be tested in accordance with the Rules for Materials.

4.2.4 A fully documented fatigue strength analysis is to be submitted indicating a factor of safety of 1,5 at the design loads based on a suitable fatigue strength criteria. Alternatively, the requirements of Pt 6, Ch 3, 4.2 Reciprocating compressors 4.2.5 to Pt 6, Ch 3, 4.2 Reciprocating compressors 4.2.9 may be used.

4.2.5 The diameter, d , of a compressor crankshaft using one of the refrigerants detailed in Pt 6, Ch 3, 2.5 Design pressures, is to be not less than that determined by the following formula, when all cranks are located between two main bearings:

$$d = V_c \left(\frac{D^2 p Z}{78,5} \left(\frac{S}{16} + \frac{ab}{a+b} \right) \right)^{1/3} \text{ mm}$$

where

a = distance between inner edge of one main bearing and the centreline of the crankpin nearest the centre of the span, in mm

b = distance from the centreline of the same crankpin to the inner edge of the adjacent main bearing, in mm

$a + b$ = span between inner edges of main bearings, in mm

d_p = proposed minimum diameter of crankshaft, in mm

where

p = design pressure, in bar g, as defined in *Pt 6, Ch 3, 2.5 Design pressures*

D = diameter of cylinder, in mm

S = length of stroke, in mm

V_c = 1,0 for shafts having one cylinder per crank, or

= 1,05 for 90° between adjacent cylinders on the same crankpin

= 1,18 for 60° between adjacent cylinders on the same crankpin

= 1,25 for 45° between adjacent cylinders on the same crankpin

= for the shaft and cylinder arrangements as detailed in *Table 3.4.1 Angle between cylinders*

$$Z = \frac{560}{\sigma_u + 160} \text{ for steel}$$

$$Z = \frac{700}{\sigma_u + 260 - 0,059d_p} \text{ for spheroidal or nodular graphite cast iron}$$

$$Z = \frac{700}{\sigma_u + 260 - 0,069d_p} \text{ for grey cast iron}$$

σ_u = specified minimum tensile strength of crankshaft material, in N/mm².

4.2.6 Where the shaft is supported additionally by a centre bearing, the diameter is to be evaluated from the half shaft between the inner edges of the centre and outer main bearings. The diameter so found for the half shaft is to be increased by six per cent for the full length shaft diameter.

Table 3.4.1 Angle between cylinders

Number of crankpins	Number of cylinders per crank	Angle between cylinders, in degrees		
		45	60	90
1 or 2	2	45	60	90
3	2	45	60	-
4	2	45	60	-
1	3	45	60	90
2	3	45	60	-
3	3	45	-	-
1	4	45	60	-
2	4	45	-	-

4.2.7 The dimensions of crankwebs are to be such that Bt^2 is to be not less than given by the following formulae:

$$= 0,4d^3, \text{ for the web adjacent to the bearing}$$

$$= 0,75d^3, \text{ for intermediate webs where a single intermediate web is common to two adjacent crank throws}$$

where

B = breadth of web, in mm

d = minimum diameter of crankshaft as required by *Pt 6, Ch 3, 4.2 Reciprocating compressors 4.2.5*, in mm

t = axial thickness of web which is to be not less than 0,45d for the web adjacent to the bearing, or 0,60d for intermediate webs, in mm.

4.2.8 Fillets at the junction of crankwebs with crankpins or journals are to be machined to a radius not less than $0,05d$. Smaller fillets, but of a radius not less than $0,025d$, may be used provided the diameter of the crankpin or journal is not less than cd ,

where

$$c = 1, 1 - 2\frac{r}{d} \text{ but to be taken as not less than } 1,0$$

d = minimum diameter of crankshaft as required by *Pt 6, Ch 3, 4.2 Reciprocating compressors 4.2.5*, in mm

r = fillet radius, in mm.

4.2.9 Fillets and oil holes are to be rounded to an even contour and smooth finish.

4.2.10 An oil level sight glass is to be fitted to the crankcase.

4.2.11 Compressors with cylinder bores in excess of 50 mm diameter are to be provided with arrangements to relieve high cylinder pressures such as would result from 'hydraulic lock' (i.e. liquid refrigerant in the cylinders). Alternatively the provision of positive means to prevent liquid refrigerant reaching the compressor may be accepted.

4.2.12 The crankcases of trunk piston compressors are to be designed to withstand a pressure equal to the maximum working pressure of the system. The crankcases of compressors of the crosshead type which are substantially isolated from the refrigerant circuit may be designed for lower pressures but are to be provided with relief valves adjusted to lift at a pressure not exceeding the design pressure, and discharging to a safe place.

4.2.13 A crankcase heater, arranged to be energised when the compressor is stopped, is to be provided.

4.3 Screw compressors

4.3.1 For screw-type compressors, the materials of the rotors and casings are to be produced, and the manufacture is to be carried out, at a works approved by LR, and in general, they are to be tested in accordance with the Rules for general machinery forgings.

4.3.2 The rotor casing is to be designed for the maximum pressure to which it may be subjected, see *Pt 6, Ch 3, 2.5 Design pressures*.

4.3.3 Where gearing is fitted to increase the rotor speed and also to locate the rotors, the gearing is to comply with *Pt 5, Ch 5 Gearing*. The manufacturer's maximum allowable tolerances for clearances and backlash between mating rotors are to be stated.

4.4 Pressure vessels and heat exchangers

4.4.1 The term 'pressure vessel' will normally apply to receivers and heat exchangers, and does not include any of the following:

- Compressors.
- Liquid refrigerant pumps.
- Pipes and their fittings.

The use of plate heat exchangers will be specially considered on submission of plans, and special tests may be required.

4.4.2 Fusion welded steel pressure vessels exposed to the pressure of the refrigerants are to be constructed in accordance with the requirements of *Pt 5, Ch 11 Other Pressure Vessels* and *Pt 5, Ch 17 Requirements for Fusion Welding of Pressure Vessels and Piping*. Plans are to be submitted for consideration if required by *Pt 5, Ch 11, 1.6 Plans*.

4.4.3 Where ammonia is the refrigerant, the pressure vessels are to be constructed to at least Class 2/1 requirements.

4.4.4 Pressure vessels for the containment of primary refrigerants for use in conventional refrigeration circuits where the pressure/saturation temperature relationship applies are not required to be low temperature impact tested unless the design temperature is lower than minus 40°C.

4.4.5 Pressure vessels are to be thermally insulated to an extent which will minimise condensation of moisture from the surrounding atmosphere. The insulation is to be provided with an efficient vapour barrier and adequately protected from mechanical damage. Prior to applying the insulation, the steel surfaces are to be suitably protected against corrosion.

4.4.6 Each pressure vessel which may contain liquid refrigerant and which is capable of being isolated is to be protected with overpressure relief devices, see *Pt 6, Ch 3, 4.15 Overpressure protection devices*.

4.5 Condensers, oil coolers and evaporators

4.5.1 In order to minimise the risk of corrosion, where the refrigerant is ammonia, the material interface between the primary refrigerant and cooling water or secondary refrigerant is to be of a suitable grade of stainless steel. Carbon-manganese steel with a suitable inhibitor would also be acceptable.

4.5.2 Space is to be provided for the withdrawal and replacement of condenser and evaporator tubes, *see Pt 6, Ch 3, 3.1 General 3.1.1*.

4.5.3 Where ammonia is used as the refrigerant, the refrigerating plant is to comply with the following additional requirements:

- (a) Automatic air purgers are to be provided, with their discharges being led through water before venting to atmosphere.
- (b) The cooling water returns from sea-water cooled condensers are not to be led into the main machinery spaces.
- (c) Fresh water condenser cooling systems are to be provided with pH meters to activate audible and visual alarms in the event of an ammonia leak.

4.6 Liquid receivers

4.6.1 Primary refrigerating systems are to be provided with liquid receivers with sufficient capacity to hold the complete refrigerant charge to prevent emission of the refrigerant to the atmosphere during servicing or repairs.

4.6.2 Alternatively, in systems using a secondary refrigerant, with a number of units, smaller receivers may be used provided the system includes a common storage receiver with sufficient capacity to hold at least the primary refrigerant charge from two units. The common receiver is to be provided with the necessary crossover connections to facilitate transfer of refrigerant to and from each unit in the system.

4.7 Oil separators

4.7.1 Oil separators are to be provided at compressor discharges and are to be fitted with a control arrangement to enable the separated oil to be returned to the compressor crankcase. Wire gauze used in separators is to be sufficiently robust and well supported.

4.8 Air coolers and cooling grids

4.8.1 Refrigerated spaces may be cooled by air coolers or cooling grids on the ceiling, bulkheads, and sides. In order to minimise the dehydration of the cargo and the frosting of the air coolers or cooling grids, the installation is to be designed to maintain the required notation temperatures with a minimum of difference between the refrigerant and space temperatures.

4.8.2 Individual spaces are to have a minimum of two independent air coolers, each comprising one or more fans and one or more refrigerant circuits in a single casing and with isolating valves. Alternatively, multiple circuits each with their own fan(s), in a single cooler casing may each be regarded as a separate cooler, provided stop valves are fitted so that each circuit may be isolated.

4.8.3 For refrigerated spaces having a net volume of 300 m³ or less, a single cooler with one circuit will be accepted.

4.8.4 The refrigeration capacity of the air cooler arrangement is to be such that the notation temperature conditions can be maintained with any one independent cooler or circuit out of action. The capacities of the fans are also to be such that they can maintain the required air flow rates (*see also Pt 6, Ch 3, 9.4 Air circulation and distribution*) and uniform air temperature throughout the refrigerated spaces, when part or fully loaded with cargo, with any one cooler or fan out of action.

4.8.5 Air cooler fan motors are to be suitably enclosed to withstand the effects of moisture.

4.8.6 Means are to be provided for effectively defrosting air coolers. Air coolers are to be provided with trays of suitable depth arranged to collect all condensate. The trays are to be provided with drains at their lowest points to enable the condensate to be drained away when the refrigerated spaces are in service. Provision is to be made for the prevention of freezing of the condensate.

4.8.7 Air coolers are to be located such that when the refrigerated spaces are loaded with cargo, adequate space is provided for the inspection, servicing and renewal of controls, valves, fans and fan motors.

4.8.8 The cooling grids in each refrigerated space are to be arranged in not less than two sections, and each section is to be fitted with valves so that it can be shut off. The notation temperature conditions are to be capable of being maintained with any one section isolated. For spaces having a net volume of 300 m³ or less, a single section will be acceptable.

4.8.9 Steel air cooler circuits and cooling grids are to be suitably protected against external corrosion.

4.9 Refrigerant pumps

4.9.1 Pumped primary and/or secondary refrigerant systems are to have a minimum of two pumps. Each pump is to be capable of operating on all cargo chambers and maintaining full duty with any one pump out of operation.

4.9.2 Primary and, where appropriate, secondary refrigerant pumps are to be provided with pressure relief valves, see *Pt 6, Ch 3, 4.15 Overpressure protection devices 4.15.13*.

4.10 Condenser cooling water pumps

4.10.1 At least two separate condenser cooling water pumps are to be installed. One of the pumps may be considered as a standby pump and may be used for other purposes, provided that it is of adequate capacity and its use on other services does not interfere with the supply of cooling water to the condensers.

4.10.2 Not less than two sea inlets are to be provided supplying sea-water to the pumps for condenser cooling. It is recommended that one of the sea inlets be provided on the port side and the other on the starboard side. The sea inlets are to be fitted in accordance with *Pt 5, Ch 13, 2.6 Piping systems – Installation*.

4.10.3 The cooling water pumps and sea inlets are to be suitably valved and cross-connected with each condenser.

4.10.4 Suitable spring-loaded safety valves are to be provided in each cooling water circuit, see *Pt 6, Ch 3, 4.15 Overpressure protection devices 4.15.13*.

4.11 Piping systems

4.11.1 All piping, valves and fittings are to be suitable for the maximum pressure to which the system can be subjected and are to comply with the requirements of *Pt 5, Ch 12 Piping Design Requirements*.

4.11.2 Pipework for Ammonia (R-717) is to comply with Class 1 requirements.

4.11.3 In addition to visual examination of pipe welds, non-destructive examination of pipe welds is to be carried out in accordance with the requirements of *Ch 13 Requirements for Welded Construction* of the Rules for Materials, to the satisfaction of the Surveyors.

4.11.4 All steel pipework on the low temperature part of the system is to be protected against external corrosion. Protective coatings are to be removed from pipe surfaces to a distance of not less than 50 mm either side of the joint weld preparations prior to welding. On completion of welding and testing a protective coating is to be applied.

4.11.5 Where brine is the secondary refrigerant, piping and tanks should not be galvanised on the brine side. If any parts of the brine system have been galvanised, the brine cooling and return tanks are to be provided with a ventilating pipe or pipes led to the atmosphere in a location where no damage will arise from the gas discharged. The ventilation pipes are to be fitted with wire gauze diaphragms which can be readily renewed.

4.11.6 Copper piping is to be manufactured in accordance with *Pt 5, Ch 12, 3 Copper and copper alloys* except in the case of small air coolers having finned pipes of sizes not greater than 19 mm outside diameter, and which have been fabricated under workshop conditions. The finned pipes may have a minimum wall thickness of 0,5 mm when used with R-22 and R-134a refrigerants.

4.11.7 Where the use of plastics pipe is proposed in a secondary refrigerant system (e.g. brine), it is to be in accordance with *Pt 5, Ch 12, 5 Plastics pipes*.

4.11.8 Pipelines are to have ample provision for expansion and contraction in service conditions. In general, expansion bends are to be used for this purpose. However, the use of metallic expansion bellows will be accepted provided test data is produced showing satisfactory strength and fatigue properties under the appropriate conditions.

4.11.9 All pipelines are to be fully supported and secured so as to prevent vibration. Flexible hoses may be used, where necessary, to prevent transmission of vibration provided the documentation in *Pt 6, Ch 3, 4.11 Piping systems 4.11.8* is provided. Flexible hoses are to be of a type which has been approved by LR, see *Pt 5, Ch 12, 7 Flexible hoses*.

4.11.10 Pipework, which may contain low temperature refrigerant, except within secondary refrigerant cooler rooms, is to be thermally insulated to an extent which will minimise condensation of moisture. Insulation in pre-formed sections is recommended. If *in situ* foamed insulation is employed, pre-production testing on site is to be carried out to the satisfaction of the Surveyor, using a 'mock-up' representative of the system to be employed.

4.11.11 All pipe insulation is to be provided with an efficient vapour barrier, care being taken to ensure that it is not interrupted in way of supports, valves, etc. Also adequate protection of insulation surfaces from mechanical damage is to be provided.

4.11.12 Where refrigerating piping is embedded in the cargo chamber insulation, the locations of the pipe joints are to be marked on the outside of the insulation lining.

4.12 Joints

4.12.1 Butt welded pipe joints are to be employed as far as practicable. Socket welded pipe joints are acceptable up to 25 mm diameter. Flanged or other joints are to be kept to a minimum and, in general, are to be restricted to connections with items of machinery or components which may have to be removed for maintenance purposes. Connections to valves are normally to be welded unless they are of a type, or in a position, which precludes *in situ* maintenance.

4.12.2 Pipe connections to fittings (e.g. gauge lines, level controls) which are likely to be subjected to heavy corrosion, are to be of heavy gauge construction, or be made from suitable corrosion resistant materials.

4.13 Liquid level indicators

4.13.1 Where liquid level indicators of the 'see-through' variety are used they are to be of the flat plate type incorporating glass (or equivalent material) of heat resistant grade.

4.13.2 All level indicators are to be provided with automatic shut-off devices and isolating valves. Plate-type sight glasses which form an integral part of the component in which they are mounted (e.g. compressor crankcases, pressure vessels) are exempt from this requirement.

4.13.3 All level indicators are to be suitable for the system maximum working pressure and tested accordingly.

4.14 Automatic expansion valves

4.14.1 Refrigerating systems with automatic expansion valves are also to be provided with efficient hand expansion valves and the arrangement is to be such that the automatic expansion valves can be by-passed and isolated.

4.14.2 As an alternative, duplicate automatic expansion valves may be fitted, each valve to be capable of the required duty and operable with the other out of action.

4.15 Overpressure protection devices

4.15.1 Refrigeration systems are to be provided with relief devices, but it is important to avoid circumstances which would bring about an inadvertent discharge of refrigerant to the atmosphere. The system is to be so designed that pressure due to fire conditions will be safely relieved.

4.15.2 Pressure relief devices are to be mounted in such a way that it is not possible to isolate them from the part of the system which they are protecting except that, where duplicated, a changeover valve may be fitted which will allow either device to be isolated for maintenance purposes without it being possible to shut off the other device at the same time.

4.15.3 Relief discharge is to be led to a safe place above deck away from personnel accesses and air intakes. Discharge piping should be designed to preclude ingress of water, dirt or debris which may cause the equipment to malfunction.

4.15.4 For ammonia systems, discharge from relief valves is to be led through water before venting to the atmosphere. Vapour detectors are to be provided in the discharge pipes to activate audible and visual alarms in the event of a leakage of ammonia.

4.15.5 A pressure relief valve and/or bursting disc is to be fitted between each positive displacement compressor and its gas delivery stop valve, the discharge being led to the suction side of the compressor. The flow capacity of the valve or disc is to exceed the full load compressor capacity on the particular refrigerant at the maximum potential suction pressure. For these internal relief valves, servo-operated valves will be accepted. Where the motive power for the compressor does not exceed 10 kW, the pressure relief valve and/or bursting disc may be omitted.

4.15.6 Compressors protected by bursting discs are to be provided with automatic shutdown in the event of high discharge temperatures.

4.15.7 Each compressor is to be provided with automatic shutdown in the event of high discharge pressure. For refrigeration systems where the maximum working pressure is less than or equal to 40 bar g the automatic shutdown is to operate at a pressure in excess of normal operating pressure but no greater than 0,9 of the maximum working pressure. For refrigeration systems where the maximum working pressure is greater than 40 bar g the automatic shutdown is to operate at a pressure in excess of normal operating pressure but no greater than 0,95 of the maximum working pressure.

4.15.8 Each pressure vessel which may contain liquid refrigerant and which is capable of being isolated by means of stop or automatic control or check valves is to be protected by two pressure relief valves or two bursting discs, or one of each, controlled by a changeover device.

4.15.9 Pressure vessels which are interconnected by pipework without valves, so that they cannot be isolated from each other, may be regarded as a single pressure vessel for this purpose, provided that the interconnecting pipework does not prevent effective venting of any vessel.

4.15.10 Omission of one of the specified relief devices and the changeover device, as required by *Pt 6, Ch 3, 4.15 Overpressure protection devices 4.15.8*, will be allowed where:

- vessels are of less than 300 litres internal gross volume; or
- vessels discharge into the low pressure side by means of a relief valve; or
- vessels operating using only cargo gas and, which can be independently isolated and gas freed during normal cargo operations provided that a shelf spare is carried.

4.15.11 Sections of systems and components which could become full of liquid between closed valves are to be provided with pressure relief devices relieving to a suitable point in the refrigerant circuit.

4.15.12 Refrigerant pumps are to be provided with pressure relief valves on the discharge side, which may relieve to the suction side, or to another suitable location.

4.15.13 Suitable spring-loaded safety valves are to be provided on the cooling liquid side of condensers and the brine side of evaporators where the pressure from any pump or expansion of the liquid in the circuit could exceed the design pressure of the system or any component forming part of the cooling system.

4.15.14 Relief valves are to be adjusted and bursting discs so selected that they relieve at a pressure not greater than the design pressure of the system, as defined in *Pt 6, Ch 3, 2.5 Design pressures*.

4.15.15 When satisfactorily adjusted, relief valves are to be protected against tampering or interference by a wire with a lead seal or similar arrangement.

4.15.16 Valves which are arranged to discharge to the low pressure side of the system are to be substantially independent of back pressure and are to be of a type which has been approved by LR.

4.15.17 The minimum required discharge capacity related to air of the pressure relief device for each pressure vessel is to be determined as follows:

$$C = D L f$$

where

C = minimum required discharge capacity related to air of each relief device, in kg/s

D = outside diameter of the vessel, in metres

L = length of the vessel, in metres

f = factor which is dependent on the refrigerant:

R-717 (Ammonia)	0,041
R-22, R-134a, R-407C	0,131
R-290 (Propane), R-600a (Isobutane)	0,082
R-410A, R-404A, R-507A	0,203
R-744 (Carbon dioxide) (when used on the low side of a cascade system)	0,082

4.15.18 The rated discharge capacity of the pressure relief valves expressed in kg/s of air is to be determined in accordance with an appropriate recognised National Standard such as *ISO 5149 Mechanical Refrigeration Systems used for Cooling and Heating – Safety Requirements*.

4.15.19 The rated discharge capacity of a bursting disc discharging to atmosphere under critical flow conditions is to be determined by the following formula:

$$d = 85,75 \sqrt{\frac{C}{P}} \text{ mm}$$

where

d = minimum diameter of free aperture of bursting disc, in mm

C = minimum required air equivalent discharge capacity, in kg/s, see *Pt 6, Ch 3, 4.15 Overpressure protection devices 4.15.17*

P = $1,1 \times$ maximum working pressure, see *Pt 6, Ch 3, 2.5 Design pressures*.

4.15.20 The bore of the discharge pipe shall be at least the same bore as the relieving device outlet. The size of a common discharge line serving two or more pressure relieving devices which may discharge simultaneously shall be based on the sum of their outlet areas. Where discharge lines are long or where the outlets of two or more pressure relieving devices are connected into a common line, the discharge piping shall be sized such that the back pressure at full relief rate does not exceed 10 per cent of the relief valve set pressure.

4.15.21 Due account is to be taken of the reaction force on a relief valve or on discharge piping during discharge and adequate support provided.

4.15.22 As carbon dioxide can form a solid powder at atmospheric pressure, there is a possibility that relief devices will choke if vented directly to atmosphere. The method used to guard against the formation of powder is to be submitted for consideration.

4.15.23 In carbon dioxide systems, overpressure protection is to be fitted to pipelines or components which can be isolated in a liquid full condition. Pressure relief devices are to be arranged such as to vent vapour at all times.

4.15.24 In cascade systems where carbon dioxide is used in combination with ammonia, the effects of carbon dioxide leaking into the ammonia side are to be considered. It may be desirable to design the ammonia system to either withstand the design pressure on the carbon dioxide side or have relief arrangements to safely deal with the additional vapour produced if a leak occurs.

4.16 Filters, driers and moisture indicators

4.16.1 Suitable filters are to be provided in the refrigerant gas lines to compressors and in the liquid lines to refrigerant flow controls. Wire gauze used in filters is to be sufficiently robust and well-supported. A filter may be combined with the oil separator required by *Pt 6, Ch 3, 4.7 Oil separators 4.7.1*. Stop valves are to be provided to allow for servicing of filters. After first commissioning of the system, the filters should be examined to confirm that elements remain intact and not collapsed.

4.16.2 Refrigerant filters, driers and moisture indicators are to be fitted in halocarbon refrigerant systems, and the arrangement is to be such that filters and driers can be by-passed, isolated and opened up without interrupting plant operations.

4.17 Purging devices

4.17.1 Where the operating pressure of the low pressure system may be below atmospheric, a purging device is to be provided, the discharge from which is to be led to a safe place above deck.

4.18 Piping in way of refrigerated spaces

4.18.1 All sounding pipes, whether for compartments or tanks, which pass through refrigerated spaces or the insulation thereof, in which the temperatures contemplated are 0°C or below, are to be not less than 65 mm bore. The pipework is to be in accordance with the requirements of *Pt 5, Ch 12 Piping Design Requirements* and *Pt 5, Ch 13, 2.9 Miscellaneous requirements*.

4.18.2 Sounding pipes to oil compartments are not to terminate within refrigerated spaces or in their air cooler spaces, or are these pipes to terminate in enclosed spaces from which access is provided to refrigerated spaces or their air cooler spaces.

4.18.3 All pipes, including scupper pipes, air pipes and sounding pipes that pass through refrigerated spaces are to be insulated.

4.18.4 Where the pipes referred to in *Pt 6, Ch 3, 4.18 Piping in way of refrigerated spaces 4.18.3* pass through chambers intended for temperatures of 0°C or below, they are also to be insulated from the steel structure, except in positions where the temperature of the structure is mainly controlled by the external temperature and will normally be above freezing point. Pipes passing through a deck plate within the ship side insulation, where the deck is fully insulated below and has an insulation ribband

on top, are to be attached to the deck plating. In the case of pipes adjacent to the shell plating, metallic contact between the pipes and the shell plating or frames is to be avoided so far as practicable.

4.18.5 The air refreshing pipes to and from refrigerated spaces need not, however, be insulated from the steelwork.

4.19 Drainage from refrigerated spaces

4.19.1 Provision is to be made for the continuous drainage of the inside of all refrigerated spaces and cooler trays. The pipework is to be in accordance with the requirements of *Pt 5, Ch 12 Piping Design Requirements* and *Pt 5, Ch 13, 3.2 Cargo holds*.

4.19.2 All drain pipes from the refrigerated spaces and cooler trays are to be fitted with liquid sealed traps, which are to be of adequate depth and readily accessible for cleaning and refilling with brine. The pipes from lower spaces situated on the tank tops are also to be fitted with bilge non-return valves.

4.19.3 Where drains from separate refrigerated spaces join a common main, the branch pipes are each to be provided with a liquid sealed trap.

4.19.4 Sluices, scuppers or drain pipes which would permit drainage from compartments outside the refrigerated spaces into the bilges of the latter are not to be fitted.

4.19.5 Screwed plugs or other means for blanking off scuppers, draining chambers and cooler trays are not to be fitted. If, however, it is specially desired to provide means for temporarily closing these scuppers, they may be fitted with shut-off valves.

4.20 Corrosion protection of metal fixtures

4.20.1 All steel bolts, nuts, hangers, brackets and fixtures which support or secure cooling appliances, piping insulation, meat rails, linings and prefabricated insulated panels, etc. are to be suitably protected against corrosion.

4.21 Pressure testing at manufacturers' works

4.21.1 Components intended for use with a primary refrigerant are to be subject to strength and leak pressure tests as detailed in *Table 3.4.2 Test pressure*.

Table 3.4.2 Test pressure

Component	Test pressure, bar g	
	Strength test	Leakage test
1. Pressure vessels	<i>See Pt 5, Ch 11 Other Pressure Vessels</i>	1,0p
2. Compressor cylinders/crankcase/casing	1,5p	1,0p
3. Valves & fittings	2,0p	1,0p
4. Pressure piping, fabricated headers, air coolers, etc.	1,5p	1,0p

Note p is the design pressure as defined in *Pt 6, Ch 3, 2.5 Design pressures*.

4.21.2 Component strength pressure tests are to be hydraulic or where suitable safety measures are taken, may be pneumatic. The latter is to be carried out with a suitable dry inert gas.

4.21.3 Component leakage pressure tests are to be carried out only after completion of satisfactory strength pressure tests. Pneumatic pressure is to be applied using a suitable dry inert gas.

4.21.4 Components for use with a secondary refrigerant or cooling water are to be hydraulically tested to 1,5 times the design pressure, but in no case less than 3,5 bar g.

4.22 Pressure test after installation on board ship

4.22.1 For primary refrigerant piping welded in place, strength pressure tests of the welds are to be carried out at a test pressure of 1,5p. This will normally take the form of a pneumatic test since hydraulic testing media such as water are not

acceptable due to their incompatibility with the primary refrigerants and the difficulty of removing all traces from a completed system.

4.22.2 Pneumatic pressure tests are to be carried out using a suitable inert gas. All pneumatic tests are potentially dangerous and due precautions are to be observed.

4.22.3 Where pneumatic tests are prohibited by relevant authorities, the tests required by *Pt 6, Ch 3, 4.22 Pressure test after installation on board ship 4.22.2* may be omitted provided non-destructive tests by ultrasonic or radiographic methods are carried out with satisfactory results on the entire circumference of all butt welds not tested in accordance with *Pt 6, Ch 3, 4.11 Piping systems 4.11.3*. Where ultrasonic tests have been carried out, the manufacturer is to provide the Surveyor with a signed statement confirming that ultrasonic examination has been carried out by an approved operator and that there were no indications of defects which could be expected to have a prejudicial effect on the service performance of the piping.

4.22.4 After completion of the test required by *Pt 6, Ch 3, 4.22 Pressure test after installation on board ship 4.22.1, Pt 6, Ch 3, 4.22 Pressure test after installation on board ship 4.22.2* or *Pt 6, Ch 3, 4.22 Pressure test after installation on board ship 4.22.3*, a leak pressure test is to be carried out using a suitable inert gas at a pressure equal to the design pressure, in the presence of the Surveyor.

4.22.5 Secondary refrigerant piping welded in place is to be hydraulically tested to 1,5 times the design pressure, but in no case less than 3,5 bar g.

■ Section 5 Refrigerant detection systems

5.1 General

5.1.1 A fixed refrigerant detection system is to be provided in the refrigerating machinery compartment or space, the discharge pipes from pressure relief valves, ventilation outlet ducts, and the cargo chambers, where appropriate.

5.1.2 The alarm system is to comply with the requirements of *Pt 6, Ch 1 Control Engineering Systems* and, as a minimum requirement, the system is to activate at a low-level concentration to give warning of refrigerant leaks, and a high-level concentration corresponding to the refrigerant's safe occupational level.

5.1.3 Detection equipment is to be so designed that it may be readily tested and calibrated, and failure of the equipment is to initiate an alarm.

5.1.4 The location of the detectors is to be determined relative to the layouts of the individual compartments and machinery spaces and are to be indicated on the plan submission.

5.1.5 For carbon dioxide systems, spaces such as machinery rooms, storage compartments, production areas on fishing vessels and valve stations, where leakage may occur, are to be fitted with detectors. Welded pipelines passing through passageways or access ducts are not considered possible leakage areas.

5.1.6 Audible and visual alarms are to be activated, located both inside and outside the affected space. The alarms are to be readily identifiable and be visible and audible in all locations within the space housing the refrigeration equipment.

5.2 Ammonia vapour detection and alarm equipment

5.2.1 A fixed detector system for ammonia is to comply with the requirements contained in *Pt 6, Ch 3, 5.2 Ammonia vapour detection and alarm equipment 5.2.2*.

5.2.2 The location of the detectors is to be determined relative to the layouts of the individual spaces and are to be indicated on the plan submission required by *Pt 6, Ch 3, 1.2 Plans and particulars*.

5.2.3 Ammonia vapour detectors are to be provided in the refrigeration machinery compartment, associated access ways, the exhaust duct, the ammonia store room and the discharge pipes from pressure relief valves.

5.2.4 Sufficient detectors are to be provided to monitor the total areas of the above spaces.

5.2.5 For vapour detection in relief valve discharge pipes, see *Pt 6, Ch 3, 4.15 Overpressure protection devices 4.15.4*.

5.2.6 Details of the refrigerant detector set points and operational philosophy are to be submitted for consideration.

■ *Section 6* **Electrical installation**

6.1 General

6.1.1 Where the refrigerating machinery is to be electrically driven, the requirements of *Pt 6, Ch 2, 2 Main source of electrical power* are to be complied with, as applicable.

6.1.2 The generating capacity available for the refrigerated installation is to be sufficient to supply power to the installation during cooling down of a complete cargo to, and maintenance of, the notation temperature conditions in all refrigerated spaces at the Rule maximum ambient and sea-water temperatures.

6.1.3 Electrical equipment is not to be installed in spaces in which ammonia refrigerant is used or stored unless it is essential for operational purposes. Where electrical equipment is installed in such spaces the requirements of *Pt 6, Ch 3, 6.2 Electrical equipment for use in explosive gas atmospheres* are to be complied with.

6.2 Electrical equipment for use in explosive gas atmospheres

6.2.1 Lighting fittings are to be of a certified safe-type and be arranged on at least two independent final branch circuits. Switches and protective devices are to interrupt all lines or phases and are to be located outside the space.

6.2.2 Where electric motors driving ventilation fans are located within the spaces, within ventilation ducts, or within three metres of ventilation openings, they are to be of a certified safe-type.

6.2.3 Monitoring control and alarm systems which are required to operate under conditions of ammonia leakage are to be of a certified safe-type.

6.2.4 Electrical equipment which is not of a certified safe-type is to de-energise automatically if the ammonia concentration within the space exceeds 1,0 per cent by volume.

■ *Section 7* **Instrumentation, control, alarm, safety and monitoring systems**

7.1 Instrumentation

7.1.1 All compressors are to be provided with the following instrumentation and automatic shutdowns:

- Indication of suction pressure (saturated temperature), including intermediate stage, when applicable.
- Indication of discharge pressure (saturated temperature), including intermediate stage when applicable.
- Indication of lubricating oil pressure.
- Indication of cumulative running hours (screw compressors).
- Automatic shutdown in the event of low lubricating oil pressure.
- Automatic shutdown in the event of high discharge pressure, *see also Pt 6, Ch 3, 4.15 Overpressure protection devices 4.15.7.*
- Automatic shutdown in the event of low suction pressure.

7.1.2 The automatic safety equipment is to be designed to fail safe and the arrangements are to be such that the compressors can be operated manually with the equipment out of action, in accordance with the relevant requirements of *Pt 6, Ch 1 Control Engineering Systems*.

7.1.3 For installations greater than 25 kW the following instrumentation, additional to that required by *Pt 6, Ch 3, 7.1 Instrumentation 7.1.1*, is to be provided:

- Indication of lubricating oil temperature.
- Indication of cooling water outlet temperature.
- Indication of cumulative running hours (reciprocating compressors).
- Indication of suction and discharge temperatures.

7.2 Control, alarm and safety systems

7.2.1 Where the refrigerating system is fitted with automatic or remote controls, so that under normal operating conditions no manual intervention by the operators is required, it is to be provided with the alarms required by *Pt 6, Ch 3, 7.2 Control, alarm and safety systems 7.2.2* and *Pt 6, Ch 3, 7.2 Control, alarm and safety systems 7.2.3* in accordance with the relevant requirements of *Pt 6, Ch 1 Control Engineering Systems*.

7.2.2 Alarms are to be initiated in the event of the following compressor fault conditions:

- High discharge pressure.
- Low suction pressure.
- Low oil pressure.
- High discharge temperature.
- High oil temperature.
- Motor shutdown.

7.2.3 Alarms are also to be initiated in the event of the following fault conditions:

- Failure of condenser cooling water pumps.
- High condenser cooling water outlet temperature.
- Failure of air cooler fans.
- High and low refrigerated air delivery temperatures.
- High secondary refrigerant temperatures.
- Failure of secondary refrigerant pump.
- Failure of air refreshing fans.
- Low level in secondary refrigerant header tank.

7.3 Temperature monitoring and recording

7.3.1 Temperature sensors are to be of a type which has been approved by LR. The number of sensors and their locations are to be such as to give a true measurement of the temperatures within the refrigerated spaces and of the cooler delivery and return air temperatures.

7.3.2 At least one automatic recorder is to be provided for the remote monitoring and continuous recording of air temperatures within the refrigerated spaces, and delivery and return air temperatures of individual air coolers. Where only one recorder is installed, at least one sensor in each refrigerated space or in its air distribution system is to be connected to a separate remote temperature indicating instrument.

7.3.3 Where the equipment controlling the temperature of the air delivered from the air coolers is equipped with a temperature indicator, this indicator will be given consideration as a standby instrument.

7.3.4 In the case of freezer fishing vessels, where the catch is frozen on board and stored in a refrigerated space, thermometer(s) hung within each space(s) will be accepted as the standby temperature indicator, provided the space is accessible at all times.

7.3.5 Automatic temperature recorders and temperature indicators are to be of a type which has been approved by LR and, where appropriate, are to be in accordance with the requirements of *Pt 6, Ch 1 Control Engineering Systems*. Approval will be granted on the basis of compliance with *Pt 6, Ch 3, 7.3 Temperature monitoring and recording 7.3.6* and *Pt 6, Ch 3, 7.3 Temperature monitoring and recording 7.3.7*, together with satisfactory environmental testing in accordance with the requirements of LR's Type Approval System. This is to include low temperature testing at the class notation minimum temperatures for any components which may be installed in environments subject to temperatures below ambient.

7.3.6 All temperature instrumentation is to be accurate to within $\pm 0,15^{\circ}\text{C}$ of the true temperature in the range minus 3°C to plus 15°C , and to $\pm 0,3^{\circ}\text{C}$ in other parts of the range and is to register to 0,1 of a degree Celsius.

7.3.7 Where the installation is intended for the carriage of frozen cargo only, the readings need only be accurate to within $\pm 0,5^{\circ}\text{C}$ of the true temperature, throughout the range.

7.3.8 A spirit-in-glass thermometer is to be carried on board for checking purposes, which is to be calibrated to a recognised National Standard.

7.3.9 Thermometer tubes with their flanges and covers are to be insulated from the deck plating, and on weather decks they are to be so arranged that water will not run down the tubes when temperatures are being taken.

7.3.10 The inside diameter of thermometer tubes is to be not less than 50 mm, and the tubes are not to be in contact with cold decks.

7.3.11 Where thermometer tubes pass through compartments other than those which they serve, they are to be efficiently insulated.

■ *Section 8* **Personnel safety equipment and systems**

8.1 Personnel safety equipment

8.1.1 Access doors, and hatches to the refrigerated spaces and air cooler spaces are to be provided with an external locking arrangement.

8.1.2 Access ways to the refrigerated space are to be designed to facilitate escape in emergencies, and the removal of stretcher-borne personnel.

8.1.3 Access ways and air cooler spaces are to be provided with an independent lighting system in accordance with the requirements of *Pt 6, Ch 2, 5.7 Lighting circuits 5.7.2* and *Pt 6, Ch 2, 5.7 Lighting circuits 5.7.4*, with the means of locking the switches in the 'on' position.

8.1.4 Where ammonia is used in refrigerating systems, the following items of safety equipment are to be provided as a minimum, and positioned in accessible protected storage (e.g. locked glass fronted cabinets) located outside the machinery compartment:

- Two sets of ammonia protective clothing (including helmet, boots and gloves).
- Two portable battery powered hand lamps (to be of certified safe-type).
- Two sets of self-contained breathing apparatus (compressed air).
- Two full face mask respirators.
- Two fire-resistant life-lines.
- Two firemen's axes.
- Two heavy duty adjustable spanners.
- Two wheel wrenches.
- Irrigation facilities or eye wash bottles containing an eye wash solution, distilled water or non-carbonated mineral water.
- Hand or foot-operated douches providing a copious supply of clean water, located outside the compartment's doors. See *Pt 6, Ch 3, 3.2 Arrangements for compartments housing machinery using ammonia 3.2.4*.

8.2 Personnel warning systems

8.2.1 A system to monitor the well-being of crew members entering refrigerated spaces is to be provided.

8.2.2 The system is to be such that at a predetermined time, after initiation, the crew member(s) receives warning that the Surveyors must indicate their well-being by accepting the warning.

8.2.3 The system is to be designed and arranged such that only an authorised person has access for enabling and disabling it and setting the appropriate intervals, and such that it cannot be operated in an unauthorised manner.

8.2.4 It is to be possible to acknowledge the warning by means of illuminated switches situated near the access doors or hatches of each refrigerated space or chambers within the space.

8.2.5 In the event that the crew member(s) fails to respond and accept the warning within an agreed specified time, the system is to immediately initiate an alarm on the bridge and in the engineers' accommodation. Manual initiation of the alarm system from the refrigerated spaces is to be possible at any time.

8.2.6 The system is to comply with the relevant requirements of *Pt 6, Ch 1 Control Engineering Systems*.

■ Section 9 Refrigerated cargo spaces

9.1 Airtightness of refrigerated spaces

9.1.1 The envelopes of individual refrigerated spaces, enclosing each temperature zone, are to be sufficiently airtight to prevent infiltration of water vapour and cross-contaminating odours. Each envelope is to be hose-tested for tightness before the insulation is installed. Alternative proposals to test with gas or air under pressure will be considered.

9.1.2 Hatch closing appliances, access doors, side loading doors, bilge and manhole plugs forming part of an insulated envelope are to be made airtight and, where exposed to ambient conditions, are to be provided with a double seal.

9.1.3 Ventilators, ducts or pipes passing through refrigerated spaces to other compartments are to be made airtight and efficiently insulated. Particular attention is to be given to insulation linings forming surfaces of air ducts. Ventilators to refrigerated spaces, if fitted, are to be provided with airtight closing appliances.

9.1.4 Refrigeration pipes passing through bulkheads or decks of refrigerated chambers or spaces are not to be in direct contact with the steelwork. The temperature of the ship's steelwork close to low temperature refrigeration piping must not be lower than that acceptable for the steel grade, see also Pt 3, Ch 2, 2.2 *Refrigerated spaces*. The airtightness of the bulkheads and decks is to be maintained and, where the pipes pass through watertight decks and bulkheads, the fittings and packing of the glands are to be both fire resisting and watertight.

9.2 Insulation systems

9.2.1 Steelwork and fittings are to be clean and dry, and suitably coated to prevent corrosion, before insulation is applied.

9.2.2 *In situ* insulation and insulating panels are to be of a type that has been approved by LR and accordingly, whenever practicable, be selected from the *List of Type Approved Products* published by LR. A copy of the *Procedure for LR Type Approval System* will be supplied on application. Prefabricated panels, with an organic foam core and metal or similar cladding both sides, are also to be manufactured under survey at a works approved by LR. Organic foam materials are to be certified as self-extinguishing. All materials are to be free from odour likely to cause taint.

9.2.3 The thickness of insulation over all surfaces and the manner in which it is supported are to be in accordance with the approved specification and plan.

9.2.4 The insulation is to be efficiently packed and, where it is of slab form, the joints are to be butted closely together and staggered. Where it is intended to use a foamed *in situ* type of insulation, full details of the process are to be submitted for approval before the work commences and pre-production testing on site is to be carried out to the satisfaction of the Surveyor, using a 'mock-up' representative of the system to be employed. Prefabricated panels are to be of a design such that, when erected, continuity of the insulation envelope is maintained without any gaps. Gaps between panels or insulation slabs are to be filled with insulating material to the satisfaction of the Surveyor.

9.2.5 The inner surfaces of insulation envelopes are to be clad with a suitable lining, such as marine grade aluminium or plywood, or equivalent material which is:

- impermeable;
- able to withstand wear and tear and the flexing of the ship's structure without fracture at the notation temperatures;
- non-corrosive, non-rotting; and
- free from odour likely to cause taint.

Where prefabricated panels are employed the outer surfaces are also to be clad with a suitable lining.

9.2.6 Insulation linings are to be constructed and fitted so that they are airtight and provide an effective vapour barrier. The means of joining prefabricated panels are to have sufficient mechanical strength to maintain a vapour barrier on the inner and outer faces. All joints, including corner, deck, deckhead and tank top intersections are to be sealed with a suitable flexible, water vapour resistant sealant or gasket. Special care is necessary where air ducts are embedded in the insulation, and where refrigeration pipes, air refreshing ducts, fan supports, fixtures, etc. protrude through the linings.

9.2.7 Hatch covers and plugs, access doors, manhole plugs, bilge limbers and plugs forming part of the insulated envelope are to be constructed of, or covered with, a suitable lining material.

9.2.8 Insulation linings and air screens, together with supports, are to be strong enough to withstand the loads imposed by either refrigerated or general cargo.

9.2.9 Successive coatings impervious to oil are to be applied before insulating the exposed plating of tank tops and bulkheads protecting tanks containing oil. The total thickness of the required coating will depend on the construction of the tank, the composition of the coating used and the method of application.

9.2.10 If the cargo to be loaded on the tank top insulation could cause damage to the lining, then additional protection is to be provided in way of the hatch and 0,6 m beyond. The protection may be of either a permanent or temporary nature.

9.2.11 Where the insulation is to support fork lift trucks, the strength of the lining and its supports is to be demonstrated. A sample of the insulation, approximately 4 m × 4 m, is to be prepared and tested by a fully loaded fork lift truck with a gross weight of 6,5 tons on one axle with a wheel pitch of 1450 mm, having single wheeled pneumatic tyres. The truck is to be driven and manoeuvred over the sample to the satisfaction of the Surveyors.

9.2.12 Prefabricated panel systems are to be fitted with suitable pressure equalising devices to prevent damage which may be caused by under or over pressure resulting from the defrosting of coolers, rapid changes in pressure on the inner and outer faces of the panels or rapid cooling of the chamber.

9.2.13 The pressure equalising devices are to be so designed as to allow the passage of air in either direction, but remain effectively closed until the pressure differential reaches a value of 10 mm water column. Heating is to be provided to protect the mechanism from freezing.

9.3 Access plugs and panels

9.3.1 Insulated plugs are to be provided in the insulation where required for easy access to the bilges, bilge suction strum boxes, cooler and chamber drains and tank manhole lids. Removable panels are to be provided for access to tank air and sounding pipes and drains.

9.3.2 Tank top insulation in way of manholes and bilge hats is to be provided with a liquid-tight steel coaming to prevent seepage into the insulation.

9.3.3 Manholes are not permitted in the bulkheads of fuel oil tanks which form part of the cargo space envelope.

9.4 Air circulation and distribution

9.4.1 When frozen cargo is carried, provision is to be made for the adequate circulation of air between the frozen cargo and all the insulation lining surfaces.

9.4.2 When cooled cargo is carried, of a type which may generate heat or emit gas, provision is to be made for the adequate circulation of air through all the stow.

9.4.3 There is to be adequate air flow between cargo and cooling grids, where fitted.

9.4.4 The air distribution arrangements are to be such that the required circulation rate and uniform distribution can be achieved when the space is part or fully loaded with cargo. The arrangement is also to be capable of maintaining uniform air temperature throughout the space with any one fan, or air cooler, or cooling grid circuit out of action, see *Pt 6, Ch 3, 4.8 Air coolers and cooling grids*.

9.5 Air refreshing arrangements

9.5.1 Where spaces are intended for the carriage of refrigerated cargoes requiring controlled ventilation, means are to be provided for air refreshing. The positions of the air inlets are to be carefully selected to minimise the possibility of contaminated air entering the spaces. Chambers or spaces are to be provided with separate inlet and discharge vents. Each vent is to have a positive airtight valve capable of closing onto a seat. It is recommended that a distance of at least 3 m is maintained between inlet and exhaust vents.

9.6 Heating arrangements for fruit cargoes

9.6.1 Where the class notation includes the symbol ‡ for the carriage of fruit cargoes, facilities for heating the refrigerated spaces are to be provided to maintain the carrying temperatures when the temperatures outside the spaces are lower.

■ Section 10**Container ships fitted with refrigerating plant to supply cooled air to insulated containers in holds****10.1 General**

10.1.1 Classed installations designed to supply refrigerated air to insulated 'porthole' containers in holds aboard container ships are to comply with the requirements of *Pt 6, Ch 3, 1 General requirements to Pt 6, Ch 3, 9 Refrigerated cargo spaces* and *Pt 6, Ch 3, 11 Acceptance trials*, so far as they are applicable, and the special requirements of this Section.

10.1.2 The classed refrigerating installation is to include the refrigerating machinery, air coolers, supply and return air ducting, and the flexible couplings between containers and the duct system. Where the arrangements are such that cell air conditioning is essential to the carriage of the containers, the air conditioning equipment and (if fitted) the insulation of the hold, deckheads, sides and tank tops are to be included in the classification.

10.2 Additional information and plans

10.2.1 In addition to those requirements detailed in *Pt 6, Ch 3, 1 General requirements* which are also applicable to refrigerated container ships, the following information is to be submitted before the work commences:

- Details of air coolers.
- Details of the design of ducting proposed, including joints, connections, insulation, vapour sealing and linings.
- Details of cell air conditioning arrangements and components.
- Details of couplings between ducting and containers, including operating arrangements.

10.3 Air coolers

10.3.1 Air ducts supplying more than ten standard 20 ft containers or five standard 40 ft containers are to have a single air cooler with multiple circuits or two independent coolers. The individual circuits or coolers are to be provided with stop valves so that each circuit or cooler may be readily isolated.

10.3.2 The refrigeration capacity of the air cooler arrangement is to be such that the temperature conditions can be maintained with any one circuit or independent cooler out of action.

10.3.3 For air ducts supplying ten standard 20 ft containers or five standard 40 ft containers or less, a single cooler with one circuit will be acceptable.

10.4 Air duct systems

10.4.1 The air ducts, together with all branches and couplings, supplying refrigerated air to insulated containers in holds, are to be made airtight. For design purposes, however, an air leakage rate of 0,5 per cent of total volume flow at the design pressure for each duct is to be taken.

10.4.2 Where air ducting is insulated on the internal surfaces, provision is to be made to prevent retention of odour which may taint subsequent cargo.

10.4.3 Couplings are to be of a type that has been approved by LR. Prototypes are to be tested under all operating conditions, witnessed by the Surveyors, to demonstrate that they extend, retract and separate satisfactorily from a 'container end wall' at the minimum temperature condition. When operated by means of air pressure they are to be supplied with air sufficiently dry to avoid ice formation. The air supply lines are to be strength pressure tested to $1,5 \times$ design pressure.

10.5 Duct air leakage and distribution tests

10.5.1 Air leakage tests on at least 10 per cent of ducting, selected at random, are to be carried out to the satisfaction of the Surveyors before the insulation is applied. The Surveyors may require further testing to demonstrate airtightness of ducting. The air leakage from each duct will depend on several factors and, while complete airtightness should be the objective, the air leakage rate for design purposes is not to exceed 0,5 per cent of total volume flow at the design pressure of 250 Pa.

10.5.2 In the case of prefabricated ducts, the prototype is to be subjected to air distribution, heat leakage and air leakage tests. Each production duct is to be tested for air leakage and is not to exceed the prototype test results by more than five per cent.

Additionally, one duct in 50 or part thereof is to be tested for heat leakage and the results are not to exceed the prototype test results by more than 10 per cent.

10.5.3 In all cases when prefabricated sections are assembled on board, the tests as detailed in *Pt 6, Ch 3, 10.5 Duct air leakage and distribution tests 10.5.2*, are to be carried out aboard the ship.

10.5.4 On application from the Owner, the air leakage tests on air ducts installed aboard the ship, as detailed in *Pt 6, Ch 3, 10.5 Duct air leakage and distribution tests 10.5.1*, may be omitted provided that:

- the installation is designed with at least 20 per cent surplus refrigerating capacity, or
- assignment of a temperature notation for the installation be deferred until verified by a thermal balance test to the Surveyor's satisfaction.

10.5.5 All ducts are to be tested for air distribution to the containers, at the manufacturer's works, by measuring the flow of air from the supply couplings while the fan is operated at full speed against the designed pressure. The air flow at each coupling is to meet the specified figure within ± 5 per cent.

10.5.6 Systems comprising rigid prefabricated ducts complete with coolers and fans are to be tested for air distribution at the place of manufacture. The remaining tests are to be carried out aboard the ship.

10.6 Cell air-conditioning arrangements

10.6.1 The cell air-conditioning equipment and ducting, and/or insulation of the holds, deckheads, sides and tank tops, is to be such as to maintain a uniform temperature throughout the cell and to ensure the ship's steelwork is maintained above the minimum temperature acceptable for the steel grade, *see also Pt 3, Ch 2, 2.2 Refrigerated spaces*.

■ **Section 11** **Acceptance trials**

11.1 Tests after completion

11.1.1 On completion of construction, the acceptance tests prescribed in *Pt 6, Ch 3, 11.3 Acceptance tests 11.3.1* are to be carried out to verify the correct functioning of the installation and its ability to maintain the lowest notation temperature conditions required for the assignment of the intended class notation. The proposed test schedules, which should include methods of testing and test facilities provided, are to be submitted for approval before these acceptance tests are started.

11.2 Thermographic survey

11.2.1 The insulated envelope of refrigerated cargo ships and, where applicable, fish factory ships, fishing vessels, fruit juice carriers and container ships is to be scanned using a thermal imaging camera. The main purpose of carrying out the infra-red scan is to verify the efficiency of the insulation system.

11.2.2 During the course of, or prior to, the acceptance trials all inner insulated surfaces, including tank tops, bulkheads, 'tween decks, insulated hatches, coamings and weather decks are to be subject to an infra-red scan.

11.2.3 Where internal obstructions preclude an internal scan, it is to be carried out externally.

11.2.4 The scan is to be conducted with the 'tween deck and main holds in total darkness and with air coolers/cooling grids isolated and all heat sources disconnected. The temperature difference, cargo hold to ambient air or sea-water temperature, is to be 15 K or more.

11.2.5 Any deficiencies or abnormalities revealed are to be investigated and repaired to the extent considered necessary by the Surveyor.

11.3 Acceptance tests

11.3.1 The acceptance tests (*see also Pt 6, Ch 3, 11.3 Acceptance tests 11.3.2 and Pt 6, Ch 3, 11.3 Acceptance tests 11.3.3*) are to comprise the following:

- (a) Verification of control, alarm, safety and refrigerant detection systems.

- (b) Test simulating failure of selected components such as compressors, fans and pumps, to verify correct functioning of alarm and systems in service.
- (c) Verification of accuracy, calibration and functioning of temperature control, monitoring and recording instrumentation.
- (d) Verification of air cooler fan outputs running at maximum speed, and air circulation rates and distribution arrangements in individual refrigerated spaces or chambers. The latter is to be undertaken firstly with all coolers in operation and secondly with any one cooler or fan out of action.
- (e) Verification of air refreshing and heating arrangements.
- (f) Verification of personnel safety devices and warning systems in refrigerated spaces.
- (g) Refrigeration and thermal balance tests to demonstrate the capability of the combined refrigerating plant and insulation envelope to maintain the lowest notation temperature to be assigned.
- (h) Refrigeration tests for refrigerated container ships carrying 'porthole' type insulated containers. If the prescribed thermal balance tests cannot be carried out due to the number of insulated containers available in the shipyard being inadequate, then, alternatively, the following separate tests will be accepted:
 - (i) Compressor capacity test.
 - (ii) Duct heat leakage test on at least 20 per cent of the insulated ducting selected at random.
 - (iii) Cell heat leakage test.
- (i) Thermographic scan to be carried out as required by *Pt 6, Ch 3, 11.2 Thermographic survey*.

11.3.2 Where a number of identical installations are constructed for the same Owner and by the same shipyard, the refrigeration and thermal balance tests required in *Pt 6, Ch 3, 11.3 Acceptance tests 11.3.1*, need only be carried out on two of the series, provided the results are satisfactory.

11.3.3 Where the cells of 'porthole' type insulated containers are not insulated, a heat leakage test will be required on the first ship of the series only.

11.4 Sea trials

11.4.1 Where the class notation includes the symbol ‡ for the carriage of fruit, or the symbol ‡ is to be assigned to a fishing vessel the following records are to be kept during the first loaded voyage:

(a) **Refrigerated cargo or container ships:**

Refrigerating machinery logs and temperature records for the refrigerated cargo spaces or containers, demonstrating the installation's capability to cool down the full cargo of fruit and maintain the notation temperature conditions.

(b) **Fishing vessels:**

Refrigerating machinery and freezing equipment logs and temperature records for the refrigerated cargo spaces, demonstrating the installation's capability to freeze the catch and maintain the notation temperature conditions.

11.5 Reporting of tests

11.5.1 On completion of the tests prescribed in *Pt 6, Ch 3, 11.1 Tests after completion*, two copies of the test schedule for the refrigerated cargo installation, giving details of all recorded data and thermal heat balance results, signed by the Surveyor and Builder are to be provided. One copy is to be placed on board the ship and the other submitted to LR.

11.5.2 At the end of the first loaded voyage a copy of the logs and temperature records requested in *Pt 6, Ch 3, 11.4 Sea trials 11.4.1* and *Pt 6, Ch 3, 11.4 Sea trials 11.4.1*, as applicable, signed by the ship's Chief Engineer, are to be submitted to LR.

Fire Protection, Detection and Extinction Requirements

Part 6, Chapter 4

Section 1

Section

1 General

2 Fire detection, protection and extinction

■ Section 1 General

1.1 Application

1.1.1 Cargo ships of 500 gross tons or more, all passenger ships and gas and chemical tankers on international voyages, where provision is made within International Conventions, are to be provided with the fire safety measures required by the *International Convention for the Safety of Life at Sea, 1974, as amended (SOLAS - International Convention for the Safety of Life at Sea)*. Fishing vessels of 45 m freeboard length and over are to be provided with the fire safety measures required by the *Torremolinos Protocol of 1993 relating to the Torremolinos International Convention for the Safety of Fishing Vessels, 1977 (Torremolinos Protocol)*.

1.1.2 Cargo ships of 500 gross tons or more, all passenger ships, and gas and chemical tankers, employed on national voyages are to comply with the fire safety measures prescribed and approved by the Government of the Flag State.

1.1.3 It is the responsibility of the Government of the Flag State to give effect to the fire protection, detection and extinction requirements of *Pt 6, Ch 4, 1.1 Application 1.1.1* and *Pt 6, Ch 4, 1.1 Application 1.1.2*. However, Lloyd's Register (hereinafter referred to as 'LR') will undertake to do this in cases where:

- (a) contracting Governments have authorised LR to apply the requirements of *SOLAS - International Convention for the Safety of Life at Sea* or the *Torremolinos Protocol* and issue the appropriate certification on their behalf; or
- (b) the Government of the Flag State is not a signatory to *SOLAS - International Convention for the Safety of Life at Sea* or the *Torremolinos Protocol*; or
- (c) the ship or fishing vessel is to be classed for restricted or special service in national waters for which the Government of the Flag State has no national requirements. In such cases, LR will apply the fire safety measures required by *SOLAS - International Convention for the Safety of Life at Sea* or the *Torremolinos Protocol*, as appropriate.

However, due consideration will be given to arrangements deemed to provide an equivalent level of fire safety, taking due cognisance of the circumstances of the restricted or special service.

1.1.4 *Pt 6, Ch 4, 2 Fire detection, protection and extinction* of this Chapter, which is within the spirit of the International Convention and Protocol requirements for ships of Convention size, is applicable to cargo ships of less than 500 gross tons (where not covered by International Conventions), fishing vessels of 12 m registered length and over but less than 45 m freeboard length, and ships not fitted with propelling machinery.

1.1.5 Consideration will be given to the acceptance of fire safety measures prescribed and approved by the Government of the Flag State in lieu of *Pt 6, Ch 4, 1.1 Application 1.1.4*.

1.1.6 Special consideration, consistent with the fire hazard involved, will be given to construction or arrangement features not covered by this Chapter.

1.1.7 Cargo ships of less than 500 gross tons intended for the carriage of dangerous goods are to comply with SOLAS 1974 as amended *Regulation 19 - Carriage of dangerous goods*¹.

■ Section 2

Fire detection, protection and extinction

2.1 General provisions

2.1.1 The provisions of these requirements, are intended to apply to new and, as far as reasonable and practicable, or as found necessary by the relevant Administration, to existing cargo ships of less than 500 gt.

2.1.2 It should be remembered that the *IBC Code - International Code for the Construction and Equipment of Ships Carrying Dangerous Chemicals in Bulk* Amended by Resolution MEPC.225(64) and *IGC Code - International Code for the Construction and Equipment of Ships Carrying Liquefied Gases in Bulk* are applicable to such ships regardless of size including those of less than 500 gt.

2.2 Definitions

2.2.1 The terms, used in these requirements are as defined in *SOLAS - International Convention for the Safety of Life at Sea 1974* (as amended).

2.2.2 The term Gross Tonnage (gt) is as defined in IMO Resolutions A.493 (XII), calculated in accordance with the 1969 Tonnage Convention and the interim scheme applicable to ships with keels laid up to 18 July 1994 in accordance with IMO Resolution A.494 (XII).

2.2.3 Service area definitions

2.2.4 'Unrestricted service' means a ship engaged on international voyages.

2.2.5 'Restricted service' is broken down into two broad categories (a) ships operating coastal or specified operating areas (b) ships operating within protected or extended protected waters.

(a) **Specified coastal service.** Service along a coast, the geographical limits of which are to be defined and for a distance out to sea generally not exceeding 20 nautical miles, unless some other distance is specified for 'coastal service' by the Administration with which the ship is registered, or by the Administration of the coast off which it is operating. A typical example might be 'Indonesian coastal service'.

Specified operating or service areas may be service between two or more ports or other geographical features, or service within a defined geographical area such as 'Red Sea Service', 'Piraeus to Thessaloniki and Islands within the Aegean Sea'.

(b) **Protected water service.** Service in sheltered water adjacent to sand banks, reefs, breakwaters to other coastal features, and in sheltered water between islands.

Extended protected water service. Service in protected waters and also short distances (generally less than 15 nautical miles) beyond protected waters in 'reasonable weather'.

2.3 Surveys and maintenance

2.3.1 The hull, machinery and all equipment required for safety aspects of every ship should be constructed and installed so as to be capable of being regularly maintained to ensure that they are at all times, in all respects, satisfactory for the ship's intended service.

2.3.2 A competent authority should arrange for appropriate surveys of the required equipment relating to fire safety aspects during construction and, at regular intervals after completion, generally as prescribed within Chapter I of *SOLAS - International Convention for the Safety of Life at Sea* (as amended). Such surveys should be carried out by the Society classing the ship or the Flag State.

2.3.3 The condition of the structural fire protection and fire safety related equipment shall be maintained to conform with the provisions of the requirements to ensure that the ship, in these respects, will remain fit to proceed to sea without danger to the ship or persons on board. The hull structure and machinery do not form part of these requirements but should be similarly surveyed and maintained.

2.4 Requirements

2.4.1 *Table 4.2.1 General fire detection, protection and extinction requirements* details the various minimum fire protection, detection and extinction arrangements that are required depending on the vessel's intended service area.

Fire Protection, Detection and Extinction Requirements

Table 4.2.1 General fire detection, protection and extinction requirements

Fire-fighting	Unrestricted	Restricted	Protected
1 FIRE PUMPS			
Ships greater than 150 gt			
Independently driven power pumps	1	1	1
Power pumps	1	1	—
Hand pumps	—	—	1
Ships less than 150 gt			
Independently driven power pumps	—	—	—
Power pumps	1	1	1
Hand pumps	1	1	—
2 FIRE HYDRANTS			
Sufficient number and so located that at least one powerful water jet can reach any normally accessible part of ship	X	X	X
3 FIRE HOSES (Length >15 m)			
	≥3	≥3	≥2
With couplings and nozzles			
4 FIRE NOZZLES			
Dual purpose (spray/jet) with 12 mm jet and integral shut-off	X	X	X
Jet may be reduced to 10mm and shut-off omitted for hand pump hoses			
5 PORTABLE FIRE-EXTINGUISHERS			
Accommodation and service spaces	≥3	≥3	≥2
Boiler rooms, etc.	≥2	≥2	≥2
Machinery spaces (one extinguisher per 375 kW of internal combustion engine power)	≥2 ≤6	≥2 ≤6	≥2 ≤6
Cargo pump-rooms			
(capacity 9 l. fluid or equivalent)	≥2	≥2	≥2
6 NON-PORTABLE FIRE-EXTINGUISHERS IN MACHINERY SPACES			
Ships greater than 150 gt	1	1	—
Ships greater than 350 gt	—	—	1

Fire Protection, Detection and Extinction Requirements

Part 6, Chapter 4 Section 2

(capacity 45 l. fluid or equivalent)			
7 FIXED FIRE-EXTINGUISHING SYSTEMS SHIPS GREATER THAN 350 gt			
Category A machinery spaces	X	X	—
Cargo pump-rooms	X	X	—
8 CARGO TANK PROTECTION			
Mobile foam appliances	X	X	X
9 FIREMAN'S OUTFIT			
Ships greater than 150 gt			
complete outfit	≥2	≥2	≥2
Ships less than 150 gt			
complete outfit	≥1	≥1	—
Fireman's axe	—	—	1
10 MEANS OF ESCAPE			
Accommodation and service spaces	2	2	2
Machinery spaces	≥1	≥1	≥1
Cargo pump-rooms	1	1	1
11 STRUCTURAL FIRE PROTECTION WHEEL HOUSE AND MACHINERY SPACES			
Separation from adjacent spaces of negligible fire risk	A-0	A-0	A-0
Separation from other adjacent spaces	A-60	A-30	A-0
Escape routes	B-0	B-0	B-0

		CLASSIFICATION
PART	1	REGULATIONS
PART	2	RULES FOR THE MANUFACTURE, TESTING AND CERTIFICATION OF MATERIALS
PART	3	SHIP STRUCTURES (GENERAL)
PART	4	SHIP STRUCTURES (SHIP TYPES)
PART	5	MAIN AND AUXILIARY MACHINERY
PART	6	CONTROL, ELECTRICAL, REFRIGERATION AND FIRE
PART	7	OTHER SHIP TYPES AND SYSTEMS
		CHAPTER 1 CONTROLLED ATMOSPHERE SYSTEMS
		CHAPTER 2 SHIPS WITH INSTALLED PROCESS PLANT FOR CHEMICALS, LIQUIFIED GASES AND RELATED PRODUCTS
		CHAPTER 3 FIRE-FIGHTING SHIPS
		CHAPTER 4 DYNAMIC POSITIONING SYSTEMS
		CHAPTER 5 SHIPS EQUIPPED FOR OIL RECOVERY OPERATIONS
		CHAPTER 6 ARRANGEMENTS FOR OFFSHORE LOADING
		CHAPTER 7 BURNING OF COAL IN SHIPS' BOILERS
		CHAPTER 8 POSITIONAL MOORING AND THRUSTER-ASSISTED POSITIONAL MOORING SYSTEMS
		CHAPTER 9 NAVIGATIONAL ARRANGEMENTS AND INTEGRATED BRIDGE SYSTEMS
		CHAPTER 10 CARRIAGE OF REFRIGERATED CONTAINERS
		CHAPTER 11 ARRANGEMENTS AND EQUIPMENT FOR ENVIRONMENTAL PROTECTION (ECO CLASS NOTATION)
		CHAPTER 12 PASSENGER AND CREW ACCOMMODATION COMFORT
		CHAPTER 13 ON-SHORE POWER SUPPLIES
		CHAPTER 14 REQUIREMENTS FOR MACHINERY AND ENGINEERING SYSTEMS OF UNCONVENTIONAL DESIGN
		CHAPTER 15 REFRIGERATION SYSTEMS AND EQUIPMENT SERVING PROVISION STORES AND AIR-CONDITIONING INSTALLATIONS
PART	8	RULES FOR ICE AND COLD OPERATIONS

Section

- 1 **General requirements**
- 2 **Plans and documentation**
- 3 **CA zones and adjacent spaces**
- 4 **Gas systems**
- 5 **Relative humidity (RH)**
- 6 **Electrical installation**
- 7 **Control instrumentation and alarms**
- 8 **Safety requirements**
- 9 **Inspection and testing on completion**

■ *Section 1* **General requirements**

1.1 General

1.1.1 The requirements of this Chapter apply to refrigerated cargo ships where a Controlled Atmosphere (**CA**) notation is requested.

1.1.2 The requirements are additional to the classification requirements for refrigerated cargo installations contained in *Pt 6, Ch 3 Refrigerated Cargo Installations*.

1.1.3 Ships provided with CA systems which are approved, installed and tested in accordance with the following requirements will be eligible for the applicable class notation specified in *Pt 1, Ch 2, 2.6 Class notations (refrigerated cargo installations (RMC), controlled atmosphere (CA) systems and carriage of refrigerated containers (CRC)) 2.6.2*.

1.1.4 An example of a typical class notation on a refrigeration installation classed with Lloyd's Register (hereinafter referred to as 'LR'), fitted with a CA system built under Special Survey, would be:

☒ **Lloyd's RMC** to maintain a temperature -29°C to +14°C with sea temperature 35°C maximum.

☒ **CA (1-12% O₂, 0-25% CO₂) RH**

1.2 Novel arrangements and design

1.2.1 Where the proposed construction of the CA system, or CA zones, is novel in design, or involves the use of unusual materials or equivalent arrangements to those specified in the following sections, special tests may be required, and a suitable descriptive note may be assigned.

1.3 Definitions

1.3.1 **CA zone** means one or more cargo chambers enclosed in an air-tight envelope.

1.3.2 **Gas** means a suitable gaseous mixture to retard the metabolic process of fresh products.

1.3.3 **Gas system** means a system which controls the levels of oxygen and/or carbon dioxide.

1.3.4 **Adjacent space** means an enclosed space adjoining a CA zone separated by watertight bulkheads or decks penetrated by pipes, cables, ducts, doors, tween deck, etc.

■ *Section 2* **Plans and documentation**

2.1 Plans of CA zones and adjacent spaces

2.1.1 The following plans and particulars of the CA zones and adjacent spaces are to be submitted in triplicate for approval before construction is commenced:

- (a) Capacity plan.
- (b) Location and installation of CA equipment.
- (c) Arrangement of CA zones in elevation and plan view.
- (d) Access arrangement.
- (e) Arrangement and use of spaces adjacent to CA zones.
- (f) Details of securing weather deck and tween deck hatch lids.
- (g) Details of securing gratings in way of hatch lids.
- (h) Details of weather deck and access hatch seals.
- (i) Door seals, scuppers, pipes, cables and ducts penetrating the decks, bulkheads, etc. together with proposed design conditions in the CA zones.
- (j) Specified leakage rate and proposals for its measurement.
- (k) Location of sampling points for CA gas and/or sensors in the CA zones and adjacent spaces.
- (l) Details of the gas supply piping system.
- (m) Details of gas freeing arrangements including fans, valves, ducts and any interlocks.
- (n) Details of pressure/vacuum valves for protecting devices in CA zones, location of outlets from P/V valves and capacity calculations.
- (o) Details of security locks provided on entry to the hatch and manhole covers, and doors leading to CA zones and adjacent spaces.
- (p) Arrangements of ventilation systems for the gas generator compartment and other adjacent spaces adjoining CA zones.

2.2 Gas supply system

2.2.1 The following plans and particulars of the gas supply system, etc. are to be submitted in triplicate for approval, before construction is commenced:

- (a) Schematic arrangements of the proposed gas supply systems and, where applicable, details of compressors, pressure vessels, membranes, storage tanks, gas cylinders, control and relief valves and safety arrangements, including pressure set points of alarm and safety devices.
- (b) Capacities of gas supply systems at different oxygen and carbon dioxide levels, if applicable.

2.3 Humidifiers

2.3.1 Where applicable, the following plans and particulars of the humidification system, etc. are to be submitted in triplicate for approval, before construction is commenced:

- (a) Specification and capacity of the system.
- (b) Principles of operation and control of relative humidities under different operating conditions.
- (c) Details of proposed equipment, nozzles, pads, heaters, pumps, steam generator, compressors, water tanks, etc.
- (d) Layouts of the equipment and the positioning of sensors and controls.

2.4 Control equipment

2.4.1 The following plans and details of the control, alarm and safety systems for CA zones, gas supply compartment and other adjacent spaces, are to be submitted in triplicate before construction is commenced:

- (a) Line diagrams of all control circuits.
- (b) List of monitored, control and alarm points.
- (c) Details of computer systems, if fitted.

- (d) Location of control panels and consoles.
- (e) Controls of all valves and dampers fitted to CA zones.
- (f) Details of oxygen and carbon dioxide analysers and arrangements for calibration.
- (g) Relative humidity (RH) sensors and details of calibration.
- (h) Details of alarm system, including location of central control panel and audible and visual warning devices.

2.5 Electrical

2.5.1 In addition to the applicable requirements of *Pt 6, Ch 2, 1.2 Documentation required for design review*, the following information and plans specific to the installed CA system are to be submitted in triplicate for approval, before construction is commenced:

- (a) Main power supply arrangement to the CA system.
- (b) Single-line diagram of the CA system which is to include rating of electrical machines, insulation type, size and current loading of cables and make, type and rating of protective devices.
- (c) A schedule of normal operating loads of CA system, estimated for the different operating conditions expected.

2.6 Testing

2.6.1 Details of the testing programme are to be submitted, including instrumentation to be used with range and calibration.

■ Section 3 **CA zones and adjacent spaces**

3.1 Air-tightness of CA zones

3.1.1 The CA zones are to be made air-tight in accordance with the requirements in *Pt 7, Ch 1, 9.3 Air-tightness of CA zones*. Particular attention is to be paid to sealing of hatches, plugs and access doors in each CA zone. Double seals are to be fitted to each opening.

3.1.2 Openings for pipes, ducts, cables, sensors, sampling lines and other fittings passing through the decks and bulkheads are to be suitably sealed and made air-tight.

3.1.3 The liquid sealed traps from bilges and drains from the cooler trays are to be deep enough to withstand, when filled with liquid which will not evaporate or freeze, the design pressure in each CA zone when taking account of the ship's motion.

3.1.4 Air refreshing inlets and outlets are to be provided with isolating arrangements.

3.2 CA zone protection

3.2.1 Means are to be provided to protect CA zones against the effect of overpressure or vacuum.

3.2.2 At least two P/V valves are to be fitted in each CA zone. They are to be set for the design conditions of the CA zone.

3.2.3 Consideration will be given to the use of a single valve in combination with other suitable means of overpressure or vacuum protection.

3.2.4 The proposed P/V valves for each zone are to be of adequate size to release any excess pressure and to relieve the vacuum at maximum cooling rate.

3.2.5 P/V valve discharges are to be located at least 2 m above deck and 10 m away from any ventilation inlets. Discharge piping is to be arranged to preclude ingress of water, dirt or debris which may cause the equipment to malfunction.

3.2.6 Pressure sensors are to be installed in locations necessary to monitor pressure of all CA zones. Pressure sensors are to be installed away from fans, air inlets and outlets.

3.3 Gas freeing of CA zones

3.3.1 The arrangements for gas freeing of CA zones are to be capable of purging all parts of the zone to ensure a safe atmosphere.

- 3.3.2 Cargo air cooling fans and the air refreshing arrangements may be used for gas freeing operations.
- 3.3.3 Gas freeing outlets are to be led to a safe place in the atmosphere 2 m above the deck, away from accommodation spaces and intakes of the fans for accommodation.

3.4 Ventilation of adjacent spaces

- 3.4.1 Deckhouses and other adjacent spaces which require to be entered regularly are to be fitted with a positive pressure type mechanical ventilation system with a capacity of at least 10 air changes per hour capable of being controlled from outside these spaces.
- 3.4.2 Adjacent spaces not normally entered are to be provided with a mechanical ventilation system which can be permanent or portable to gas free the space prior to entry.
- 3.4.3 Ventilation inlets are to be arranged so as to minimise recycling any gas and are to be at least 10 m in the horizontal direction away from the ventilation outlets.

■ *Section 4* **Gas systems**

4.1 General

- 4.1.1 Means are to be provided to achieve and maintain the required oxygen and/or carbon dioxide levels in the CA zones. This may be accomplished by the use of stored gas, portable or fixed gas generating equipment or other equivalent arrangements. The arrangements are to be such that a single failure will not cause a complete loss of gas supply to the CA zones.
- 4.1.2 The gas system is to have sufficient capacity to make good any gas loss from the CA zones and to maintain a positive pressure in all CA zones.
- 4.1.3 The gas system is also to be able to:
- Deliver gas at 125 per cent of the specified flow rate with two compressors operating.
 - Maintain the specified gas levels in all CA zones when operating 24 hours per day with one unit on stand-by.
- 4.1.4 Air intakes are to be located to ensure that contaminated air is not drawn into the compressors.
- 4.1.5 Where it is intended to supply gas by means of stored gas bottles, the arrangements are to be such that depleted bottles may be readily and safely disconnected and charged bottles readily connected.

4.2 Location

- 4.2.1 Fixed gas generating equipment, gas bottles or portable gas generators are to be located in a compartment reserved solely for their use. Such compartments are to be separated by a gastight bulkhead and/or deck from accommodation, service and control station spaces. Access to such compartments is to be only from the open deck.
- 4.2.2 Gas piping systems are not to be led through accommodation, service and machinery spaces or control stations.

4.3 Gas supply

- 4.3.1 The gas systems are to be designed so that the pressure which they can exert on any CA zone will not exceed the design pressure of the zone.
- 4.3.2 During initial operation, arrangements are to be made to vent the gas outlets from each generator to the atmosphere. All vents from gas generators are to be led to a safe location on the open deck.
- 4.3.3 Where gas generators use positive displacement compressors, a pressure relief device is to be provided to prevent excess pressure being developed on the discharge side of the compressor.
- 4.3.4 Suitable arrangements are to be provided to enable the supply main to be connected to an external supply.
- 4.3.5 Where it is intended that gas systems are to be operated unattended, the required CA zone environment is to be automatically controlled.
- 4.3.6 Means of controlling inadvertent release of nitrogen into CA zones, such as locked valves, are to be provided.

4.4 Gas supply compartment ventilation and alarm

- 4.4.1 The gas supply compartment is to be fitted with a mechanical extraction ventilation system providing a rate of at least 20 air changes per hour based on the total empty volume of the compartment.
- 4.4.2 Ventilation ducts from the gas generator/supply compartment are not to be led through accommodation, service and machinery spaces or control stations.
- 4.4.3 The air outlet duct is to be led to a safe place on the open deck.
- 4.4.4 The gas supply compartment is to be provided with a low oxygen alarm system.

■ *Section 5*
Relative humidity (RH)

5.1 Humidification

- 5.1.1 Where a humidification system is fitted, the following requirements are to be complied with:
- (a) The supply of fresh water for humidification is to be such as to minimise the risk of corrosion and contamination of the cargo.
- (b) To prevent damage or blockage in the humidification system caused by water freezing, the air, steam or water pipelines in the cargo chambers are to be installed to facilitate ease of drainage and are to be provided with suitable heating arrangements.

■ *Section 6*
Electrical installation

6.1 General

- 6.1.1 In addition to the requirements of *Pt 6, Ch 2 Electrical Engineering*, the following requirements are to be complied with:
- (a) The electrical power for the CA plant is to be provided from a separate feeder circuit from the main switchboard.
- (b) Under sea-going conditions, the number and rating of service generators are to be sufficient to supply the cargo refrigeration machinery and CA equipment in addition to the ship's essential services, when any one generating set is out of action.

■ *Section 7*
Control instrumentation and alarms

7.1 General

- 7.1.1 An alarm system for monitoring the atmosphere in CA zones is to be installed which may be integral with the machinery space alarm system as required by *Pt 6, Ch 1, 2.3 Alarm systems, general requirements*.
- 7.1.2 Where alarms are displayed as group alarms in the main machinery space alarm system, provision is to be made to identify individual alarms at the refrigerated cargo control station.
- 7.1.3 The pressure in each CA zone is to be monitored and an alarm initiated when the pressure is too high or too low.
- 7.1.4 Where the **RH** notation is to be assigned, humidity sensors are to be installed in each of the CA zones and are to initiate an alarm when the relative humidity (RH) falls below or exceeds the predetermined set values.
- 7.1.5 Gas sensors or analysers are to be provided to monitor gas content in CA zones, see *Pt 7, Ch 1, 7.3 Gas analysers and sampling* and *Pt 7, Ch 1, 7.4 Gas sensors*.
- 7.1.6 Gas analysers and sensors are to be calibrated automatically once in every 24 hours. An alarm is to be initiated if accuracy is outside tolerance limits.

- 7.1.7 Direct readout of the gas quality within any CA zone is to be available to the operating staff on demand.
- 7.1.8 At least one automatic recorder is to be provided for the remote monitoring and recording of O₂ and CO₂ levels in each CA zone.
- 7.1.9 Alarms are to be initiated in the event of O₂ or CO₂ levels in each CA zone falling below or exceeding the predetermined set values.

7.2 Gas systems

7.2.1 Where air compressors are to be used for gas production, alarms are to be initiated for the following conditions:

- High lubricating oil temperature.
- High differential pressure across the filters.
- Electric supply failure.

The compressors are to shutdown automatically in the event of:

- High discharge air temperature.
- High discharge air pressure.
- Low lubricating oil pressure.
- High pressure in CA zone.

7.2.2 Instrumentation is to be fitted for indicating continuously:

- (a) Gas pressure.
- (b) Gas temperature.
- (c) Gas content.
- (d) Gas flow.

7.3 Gas analysers and sampling

7.3.1 Where analysers are fitted, at least two analysers for oxygen and carbon dioxide having a tolerance of $\pm 0,1$ per cent by volume are to be provided to determine the content of the circulated gas within the CA zones.

7.3.2 Two separate sampling points are to be located in each CA zone and one sampling point in each of the adjacent spaces. The arrangements are to be such as to prevent water condensing and freezing in the sampling lines under normal operating conditions. Filters are to be provided at the inlet to sampling point lines.

7.3.3 Arrangements of the gas sampling points are to be such as to facilitate representative sampling of the gas in the space.

7.3.4 Where gas is extracted from the CA zones via a sampling tube to analysers outside the space, the sample gas is to be discharged safely to the open deck.

7.3.5 Provision is to be made for gas sampling by means of portable equipment as required by *Pt 7, Ch 1, 9.6 Safety, alarms and instrumentation 9.6.3*.

7.3.6 The sampling frequency is to be at least once per hour.

7.4 Gas sensors

7.4.1 Where sensors are fitted, at least two sensors for each of O₂ and CO₂, having a tolerance of $\pm 0,1$ per cent are to be installed in each CA zone to monitor gas levels.

7.4.2 Gas sensors may be used for indication and alarm.

■ Section 8 **Safety requirements**

8.1 Personnel safety

8.1.1 CA zones are to be clearly labelled with 'Caution' and 'Danger' signs to alert personnel.

- 8.1.2 Entry hatch and manhole covers, doors leading to the CA zones and adjacent spaces are to be fitted with acceptable security-type locks and alarms activated when covers and doors are opened. The alarms are to be placed in a manned location.
- 8.1.3 All doors and access hatches to CA zones which may be under pressure are to open outwards and are to be fitted with secondary catches to prevent injury or damage during opening.
- 8.1.4 At least two portable oxygen sensors are to be provided to sample the oxygen level in all CA zones and adjacent spaces.
- 8.1.5 A means of communication is to be provided between CA zones and an attended location on deck.
- 8.1.6 Medical first aid equipment, including at least one set of oxygen resuscitation equipment, is to be provided on board.

■ *Section 9* **Inspection and testing on completion**

9.1 General

- 9.1.1 CA system trials are to be witnessed on board by the LR Surveyor, before the system is put into service and before a certificate is issued. These trials are in addition to any tests which may have been carried out at the manufacturer's works.
- 9.1.2 An Operating and Safety Manual for the guidance of the ship's staff is to be provided, covering the following topics:
- Principal information on the use of CA.
 - Complete description of the CA installation on board.
 - Hazards of low oxygen atmospheres and consequential effects on human life.
 - Countermeasures when exposed to low oxygen atmospheres.
 - Instructions for operation, maintenance and calibration of all gas detectors.
 - Instructions for use of portable oxygen analysers with alarm for personal protection.
 - Prohibition of entry to spaces under CA.
 - Loading instructions prior to injection of gas.
 - Procedure for checking security of CA zones, doors and access hatches prior to injection of gas.
 - Gas freeing procedure for all CA zones.
 - Procedure for checking atmosphere of CA zones before entry.

9.2 Gas supply and sampling systems

- 9.2.1 The gas supply main and branches are to be pressure and leak tested. The test pressures are to be 1,5 and 1,0 times the design pressure respectively.
- 9.2.2 All gas sampling lines are to be leak tested using a vacuum or overpressure method.

9.3 Air-tightness of CA zones

- 9.3.1 Air-tightness of each CA zone is to be tested and the results entered on the certificate. The measured leakage rate of each zone is to be compared with the specified value.
- 9.3.2 Either a constant pressure method or a pressure decay method is to be used to determine the degree of air-tightness.
- 9.3.3 If the constant pressure method is used, the test is to be carried out at the design pressure of the CA zones.
- 9.3.4 If the pressure decay method is used, the time for the pressure to drop from 350 Pa to 150 Pa is to be measured and the leakage is to be calculated using the following formula:

$$A.L. = \frac{7,095 \times V}{t}$$

where

A.L. = air leakage, in m³/h

V = volume of zone, in m³

where

t = time, in seconds

7,095 = constant for 200 Pa pressure decay.

During this test, adjacent zones are to be kept at atmospheric pressure.

9.4 Gas system performance

9.4.1 Capability of the gas system to supply the gas at the specified flow rate and condition is to be verified by tests.

9.4.2 If the notation conditions cannot be verified during testing, assignment of the notation is to be deferred until log book entries confirm the achievement of the specified conditions in every CA zone during a loaded passage.

9.5 Gas freeing

9.5.1 The gas freeing arrangements are to be tested to demonstrate that they are effective.

9.6 Safety, alarms and instrumentation

9.6.1 The control, alarm and safety systems are to be tested to demonstrate overall satisfactory performance of the control engineering installation. Testing is also to take account of the electrical power supply arrangements, *see also Pt 6, Ch 1, 2.3 Alarm systems, general requirements*.

9.6.2 Locking arrangements of all CA zones and adjacent spaces where gas may accumulate, provision of warning notices at all entrances to such spaces, communication arrangements and operation of alarms, controls, etc. are to be examined.

9.6.3 The provision of portable gas detectors and personnel oxygen monitors are to be verified by the LR Surveyor. Suitable calibrated instruments for measuring the levels of O₂, CO₂ and humidity, gas pressure and gas flow to the CA zones, are to be provided for testing. Their accuracy is to be verified.

Ships with Installed Process Plant for Chemicals, Liquefied Gases and Related Products

Part 7, Chapter 2

Section 1

Section

- 1 **Introduction**
- 2 **Class notations**
- 3 **Plans and particulars**
- 4 **Materials**
- 5 **Process plant characteristics**
- 6 **Hull construction**
- 7 **Mechanical equipment for the process plant**
- 8 **Boilers and other pressure vessels for the process plant**
- 9 **Pumping and piping systems for the process plant**
- 10 **Firing arrangements of steam boilers, fired pressure vessels, heaters, reformers, etc.**
- 11 **Electrical equipment for the process plant**
- 12 **Control engineering for the process plant**
- 13 **Plant blowdown systems**
- 14 **Plant flare gas systems**
- 15 **Supply and discharge arrangements for feedstock and product**
- 16 **Ventilation of the process plant and other spaces associated with the process plant operation**
- 17 **Gas detection**
- 18 **Fire protection, detection and extinction**

■ Section 1 Introduction

1.1 Scope

1.1.1 This Chapter is intended for the classification of self-propelled or non-self-propelled ships with specialised structures which have plant installed on board for the processing of chemicals, liquefied gases and related products, where permitted by the Flag Administration, and which fall into one of the following environmental categories:

- (a) Ships which have plants operable while navigating at sea.
- (b) Ships which have plants operable at sea, but only while the ship is attached to an offshore mooring facility.
- (c) Ships which can navigate at sea, but whose plants are intended to be operated only while the ships are in harbour or similarly protected waters.
- (d) Specialised ships, including pontoons, barges and similar structures which are designed as sea transportation vehicles to carry non-operative process plants, but which are specially constructed to be fully supported by the sea bed when the plants are operative.

1.1.2 Each category in *Pt 7, Ch 2, 1.1 Scope 1.1.1* may include provision for the storage of the products used in the process or processes concerned.

Ships with Installed Process Plant for Chemicals, Liquified Gases and Related Products

Part 7, Chapter 2

Section 1

1.2 General

1.2.1 The Rules are framed on the understanding that ships will not be operated in environmental conditions more severe than those agreed for the design basis and approval, without the prior agreement of Lloyd's Register (hereinafter referred to as 'LR').

1.2.2 Except as indicated in this Chapter, the hull, propulsion machinery, auxiliary machinery, equipment for essential services of the ship, electrical installations and control engineering systems are to comply with the relevant Sections of Parts *Pt 3 Ship Structures (General)*, *Pt 4 Ship Structures (Ship Types)*, *Pt 5 Main and Auxiliary Machinery* and *Pt 6 Control, Electrical, Refrigeration and Fire*, the *Rules for Ships for the Carriage of Liquid Chemicals in Bulk* and the *Rules for Ships for Liquefied Gases*, where applicable. Hulls made of reinforced or prestressed concrete will be specially considered.

1.2.3 The additional hull structural requirements for Category 3 ships to enable them to be satisfactorily grounded on prepared foundations will be specially considered. Full details of the intended foundations and the local conditions at the site are to be submitted for use in assessing the hull structural capability, etc.

1.2.4 Where the process plant is intended to operate in close proximity to bulk storage of feedstocks and/or products, further consideration may be necessary in addition to that contained in this Chapter, particularly with regard to the provision of effective separation, methods of storage, loading and discharging arrangements.

1.2.5 For ships of all categories in *Pt 7, Ch 2, 1.1 Scope 1.1.1* except Category 1A, provision is to be made for purging, gas freeing, inerting or otherwise rendering safe the plant and process storage facilities before the ship proceeds to sea or changes location. The provisions to be adopted, if any, when a ship of Category 1A enters harbour will be specially considered.

1.2.6 In addition to the requirements for periodical surveys, a general examination of the ship, machinery and process plant is to be carried out by LR's Surveyors before and after a ship, of any category other than 1A, changes location. Every precaution is to be taken to ensure safety during such examination.

1.2.7 Requirements additional to those of this Chapter may be imposed by the National Authority with whom the ship is registered and/or by the Administration within whose territorial jurisdiction the process plant is intended to operate.

1.3 Classification of ship

1.3.1 A ship built in accordance with the requirements of this Chapter, or in accordance with requirements equivalent thereto, will be assigned an appropriate class in the *Register Book*, as indicated in *Pt 7, Ch 2, 2 Class notations*, and will continue to be classed so long as it is found, upon examination at the prescribed surveys, to be maintained in a safe and efficient condition, see also *Pt 7, Ch 2, 1.4 Certification of process plant 1.4.6*.

1.3.2 For each category described in *Pt 7, Ch 2, 1.1 Scope 1.1.1*, classification covers the hull, containment systems for stored products, propulsion machinery, auxiliary machinery used for essential services, and equipment necessary to maintain a suitable environment within which the plant may safely operate.

1.3.3 In general, classification will not be extended to the process plant itself, and the classification requirements do not relate to the specialised machinery, equipment and associated piping, etc. which is solely concerned with the production operations, except where the design and/or arrangements of such equipment and piping may affect the safety of the vessel.

1.3.4 When reliquefaction plant is installed, and the plant and equipment are in accordance with the requirements of the *18 Rules and Regulations for the Construction and Classification of Ships for the Carriage of Liquefied Gases in Bulk, July 2015*, consideration will be given to classing the plant in accordance with *Pt 1, Ch 2, 2.6 Class notations (refrigerated cargo installations (RMC), controlled atmosphere (CA) systems and carriage of refrigerated containers (CRC))*.

1.4 Certification of process plant

1.4.1 Process plant will be required to be certified by LR, and a note to the effect that this has been carried out will be appended to the class notation in the *Register Book*.

1.4.2 The certificate will include a brief description of the process plant, indicating the chemical(s) processed and the end products.

1.4.3 The certificate of the plant will cease to be valid if a significant alteration is made to the plant or the arrangements on board without the written approval of LR. This provision does not exclude the direct replacement of any item by a substitute part which has been approved and tested by LR.

1.4.4 The process plant will be required to be surveyed by LR's Surveyors at intervals to be prescribed by the Committee, dependent on the process involved.

Ships with Installed Process Plant for Chemicals, Liquified Gases and Related Products

Part 7, Chapter 2

Section 2

1.4.5 The class notation for the ship will, in general, state that the process plant is not classed but certificated by LR and periodically surveyed by LR's Surveyors.

1.4.6 The maintenance of the class of the ship while the plant is in operation will be dependent upon a valid certificate and the plant being found, upon examination at the prescribed surveys, to be maintained in a safe and efficient condition.

1.4.7 The plant certificate is not to be taken as a recommendation for, or an approval of, the process or processes.

■ Section 2 Class notations

2.1 Ship notations

2.1.1 Ships of Category 1A, which have chemical process plants designed to operate while the ship is navigating at sea, will be eligible to be classed '100A1 Chemical Process Factory', see also Pt 7, Ch 2, 1.4 Certification of process plant 1.4.5.

2.1.2 Ships of Category 1B, which have chemical plants designed for operation at sea while the ship is specially moored, anchored or otherwise linked to the shore, sea bed or other stationary vessel or structure, will be eligible to be classed '100A1 (T) moored (oil, ammonia, etc.) processing (tanker, barge, etc.) for service at . . .', see also Pt 7, Ch 2, 1.4 Certification of process plant 1.4.5.

2.1.3 Ships of Category 2, which have chemical plants installed and designed for operation while the ship is in harbour, will be eligible to be classed '100A(T) chemical process plant installed – for operation only when moored in harbour', see also Pt 7, Ch 2, 1.4 Certification of process plant 1.4.5.

2.1.4 Specialised ships of Category 3 which have chemical plants designed to operate only while the ship is fully supported on the sea bed, will be eligible to be classed 'A chemical process plant pontoon/platform – to be operated only when grounded on prepared foundations at...', see also Pt 7, Ch 2, 1.4 Certification of process plant 1.4.5.

2.2 Additional notations

2.2.1 A special chemical cargoes notation may be assigned to ships where raw materials or products are stored or retained on board in bulk.

2.2.2 The Committee may append details of process, product storage, safety or other particulars to the notation as it considers necessary.

2.2.3 Ships of Category 1B or 2 which have process plants installed solely for the purposes of the physical liquefaction of impure feedstock gases at low temperatures and the storage of the purified liquefied gases (where the chemical treatment of the impurities is an incidental process) will be assigned additional notations to those stated in Pt 7, Ch 2, 2.1 Ship notations 2.1.2 or Pt 7, Ch 2, 2.1 Ship notations 2.1.3 such as 'for liquefaction and storage of methane, etc. in independent tanks Type B, etc. – maximum pressure – minimum temperature'.

2.3 Special mooring and linking arrangements

2.3.1 Where the process plant is operable only when the ship is specially moored, anchored or otherwise linked to the shore, sea bed or other stationary vessel, and the equipment and/or other linking arrangements and components have been approved by the Committee as suitable and sufficient for the intended service, an equipment character, T, will be assigned in addition, or as an alternative, to the equipment character 1, as appropriate.

2.3.2 For the purpose of the Rules, the word 'linked' is to be taken to include spuds, retractable legs, floating or submerged pipelines connecting directly to the ship, ship to shore electrical connections, etc. which restrain the ship in its operating position, or which require such restraint to be applied and the failure of which could hazard the ship.

Ships with Installed Process Plant for Chemicals, Liquified Gases and Related Products

Part 7, Chapter 2

Section 3

■ Section 3 Plans and particulars

3.1 General

3.1.1 Before the work is commenced, plans in triplicate, together with the relevant information as detailed in this Section, are to be submitted for consideration. Any subsequent modifications are subject to approval before being put into operation.

3.1.2 Any alterations to basic design, construction, materials, manufacturing procedure, equipment, fittings or arrangements of the process are to be re-submitted for approval.

3.1.3 For Category 1 ships, the plant is to be capable of sustaining an emergency condition at full operating temperatures and pressures with the hull statically listed to an angle of $22\frac{1}{2}^{\circ}$ and statically trimmed to an angle of 10° beyond the maximum normal operating trim. These angles may be modified by the Committee in particular cases as it considers necessary. The stress calculations for the plant and the supporting structure are to take account of this condition. Wind loads need not be considered to be acting during this emergency condition.

3.1.4 For Category 2 ships, the plant is to be capable of sustaining an emergency condition at full operating temperatures and pressures with the hull statically listed to an angle of 15° and statically trimmed to an angle of 5° beyond the maximum normal operating trim. These angles may be modified by the Committee in particular cases as it considers necessary. The stress calculations for the plant and the supporting structure are to take account of this condition. Wind loads need not be considered to be acting during this emergency condition.

3.2 Hull construction

3.2.1 For all categories of ship, the plans and information detailed in *Pt 7, Ch 2, 3.2 Hull construction 3.2.2* are to be submitted, in addition to those required by *Pt 3, Ch 1, 5 Information required, Cargo Containment* of the Rules for Ships for Liquid Chemicals or *18, Ch 4 Cargo Containment* of the Rules for Ships for Liquefied Gases, as applicable.

3.2.2 Plans showing the general arrangement of the ship are to be submitted, giving the location of the following:

- Hatches and other openings to enclosed plant spaces and adjacent cofferdams.
- Doors, hatches, ventilation and other openings to crew accommodation, stations essential for operation at sea, control stations, store rooms and workshops.
- Coated tanks or tanks constructed of special material.
- Additional structure associated with the plant above the deck.
- Proposed grouping of areas within the plant for segregation purposes.

3.2.3 Plans for mooring, anchoring and linking, as applicable, together with relevant wind and sea data are to be submitted for information.

3.2.4 Plans outlining the containment arrangements in the event of an accident, together with all relevant information, are to be submitted.

3.2.5 Particulars of the marine environment and safety arrangements associated with the process plant are to be submitted, including:

- Arrangements for preventing the ingress of water into the ship or structure where process plant and equipment protrude through the weather deck.
- Proposed emergency flooding procedures and their control.

3.2.6 Particulars of the proposed storage arrangements of hazardous and/or toxic substances, feedstocks and products in bulk, on the ship or structure, are to be submitted.

3.3 Process plant

3.3.1 A description of the expected method of operation of the process plant and a diagram showing the process flow are to be submitted.

3.3.2 General arrangement plans of the process plant showing the hazardous and safe zones and spaces are to be submitted, indicating the following:

Ships with Installed Process Plant for Chemicals, Liquefied Gases and Related Products

- Spaces where toxic gases or vapours may accumulate.
- Spaces where flammable gases or vapours may accumulate.
- Areas maintained at an over-pressure to prevent the ingress of such gases or vapours.

3.3.3 Details of the flammability, toxicity, corrosivity and reactivity of the substances entering, being processed and leaving, or stored in, each compartment, together with details of any exothermic and hazardous reactions particularly with regard to sea-water and other materials normally found in the marine environment, are to be submitted.

3.3.4 Plans of the layout of the process plant indicating the hatches and other openings to enclosed plant spaces and cofferdams are to be submitted.

3.3.5 Details and arrangements of the blow-down systems, including quantities of materials and the capacity and working pressure of the containers installed for the reception of the materials to be blown down, are to be submitted.

3.3.6 Proposals for de-watering blow-down tanks in which hot oils and/or chemicals are discharged are to be submitted.

3.3.7 Proposals for the purging, gas freeing, inerting or otherwise rendering safe of the process plant and storage facilities are to be submitted.

3.3.8 Particulars of the arrangements for protecting the process plant systems and vessels against temperature, over-pressure and vacuum are to be submitted.

3.3.9 Proposals for the disposal of hazardous or toxic gases and liquid effluents during normal plant operation, including any proposed flare systems, are to be submitted.

3.3.10 Particulars of the proposals for isolating the ship or structure from the shore installation and/or lightering ships or vessels, where applicable, and from the supply of fuel to boilers, etc. in the process plant and the return flow of chemicals or process effluent, are to be submitted, including:

- Feedstock supply and product discharge, with details of the arrangements showing the location of shut-off valves and of the control and indicating stations.
- The process plant parameters and analysis of transient conditions under which emergency shutdown will be initiated and the time estimated to obtain a safe environment.
- The proposed emergency procedures for controlled shutdown of the process plant, i.e. depressurising, inerting, etc. and the arrangements for the continued operation of the essential services necessary to allow for such controlled shutdown under the emergency conditions of *Pt 7, Ch 2, 3.1 General 3.1.3* or *Pt 7, Ch 2, 3.1 General 3.1.4*, as applicable.

3.3.11 Plans for the ventilation of process plant compartments are to be submitted, together with the following information:

- Location of hazardous and safe zones and spaces.
- Location of all possible sources of ignition.
- Location of air inlets and outlets.
- Number of complete air changes per hour.
- Estimated maximum and minimum ambient temperatures for the regions in which the plant is to operate.
- Expected heat loss of the process plant to the compartment environment.

3.3.12 Particulars of any dust or gas explosion hazard in the enclosed compartments of the process plant are to be submitted.

3.3.13 Proposals for the decontamination of the process plant compartments are to be submitted.

3.3.14 Proposals for the detection of vapour or gas and of oxygen deficiency in the process plant compartments are to be submitted.

3.4 Mechanical equipment associated with the process plant

3.4.1 A list of mechanical equipment associated with the process plant, with the exception of any boilers and other pressure vessels, to be installed in the ship or structure is to be submitted.

3.4.2 Details of safety and relief devices and their discharge arrangements are to be submitted.

3.4.3 When required, in order to facilitate inspection, plans showing the materials of construction, working pressures and temperatures, maximum power and revolutions per minute, as applicable, are to be submitted before the work is commenced.

3.4.4 Calculations of the torsional vibration characteristics of the shafting systems, where applicable, are to be submitted in accordance with the requirements of *Pt 5, Ch 8 Shaft Vibration and Alignment*.

Ships with Installed Process Plant for Chemicals, Liquefied Gases and Related Products

3.5 Boilers and other pressure vessels associated with the process plant

3.5.1 Plans of the boilers and other pressure vessels, including the proposals for the support of the vessels, are to be submitted.

3.5.2 Details of the safety and relief devices and their discharge arrangements are to be submitted.

3.5.3 Stress calculations are to be submitted, taking into account the ship linear and angular accelerations, roll and pitch amplitudes, ship flexure and wind loads appropriate to any condition which may normally arise at sea. Where applicable, calculations for the emergency condition in *Pt 7, Ch 2, 3.1 General 3.1.3* or *Pt 7, Ch 2, 3.1 General 3.1.4* are to be submitted. Due consideration is to be given to the effects of thermal expansion and contraction on the support points of the vessels.

3.5.4 Outline plans of all types of fired equipment, ventilation arrangements with projected casing temperatures, uptake arrangements, gas and/or fuel oil burning arrangements and controls are to be submitted.

3.6 Pumping and piping systems associated with the process plant

3.6.1 Plans of the process plant piping systems, showing the materials of construction, scantlings, support and expansion arrangements, together with the calculations, are to be submitted for consideration.

3.6.2 The following diagrammatic plans for systems associated with the process plant are to be submitted, in addition to those required by *Pt 5, Ch 13 Ship Piping Systems* and *Pt 5, Ch 15 Piping Systems for Oil Tankers* or Chapter V of the Rules for Ships for Liquefied Gases, as applicable:

- The Shipbuilder's plan of the general pumping arrangements, including air and sounding pipes and any cross flooding pipes and fittings.
- Pumping arrangements at the fore and aft ends, drainage of cofferdams and process spaces.
- Bilge, ballast and fuel oil pumping arrangements in the process plant machinery space, including the capacities of the pumps on bilge service.
- Arrangement of fuel oil pipes and fittings at settling and service tanks.
- Arrangement of gas and/or fuel oil piping in connection with gas and/or oil burning arrangements.
- Fuel oil overflow systems, where fitted.
- Arrangement of boiler feed system.
- Arrangement of compressed air systems for the process plant.
- Arrangements of lubricating oil and cooling water systems, fuel oil settling, service and other oil tanks not forming part of the ship's structure.

3.6.3 Plans showing the arrangement and dimensions of main steam pipes, with details of flanges, bolts and weld attachments and particulars of the materials of the pipes, flanges, bolts and welding consumables, are to be submitted for consideration.

3.6.4 Details of the safety and relief devices and their discharge arrangements are to be submitted.

3.7 Electrical equipment for the process plant

3.7.1 Details of the electrical system(s) are to be submitted, including the following:

- A statement quoting the standard or Code of Practice in accordance with which the installation has been designed.
- A statement quoting the standard of design and/or manufacture of electrical equipment, e.g. BS, NEMA, VDE, etc.
- A schedule of the normal operational loads on the system, estimated for the different operating conditions expected.
- Expected range of ambient temperature.

3.7.2 The following line diagram plans and particulars are to be submitted:

- General arrangement plan of the process plant showing the location of the major items of electrical equipment.
- Line diagram of the installation(s) indicating the rating of the various items of rotating machinery, converters, transformers and protective devices, together with the types and sizes of cables and the makes and types of protective devices.
- Arrangement plans and circuit diagrams of the switchboards.
- Calculations of short-circuit currents at the main switchboards, sub-switchboards and the secondary side of transformers.
- General arrangement plan of the process plant showing the location of electrical equipment in hazardous zones, together with the Code of Practice on which they are based.

Ships with Installed Process Plant for Chemicals, Liquefied Gases and Related Products

Part 7, Chapter 2

Section 4

- A schedule of safe-type electrical equipment located in hazardous zones, giving details of the type of equipment employed, the certifying authority and the certificate number.
- 3.7.3 Written confirmation and Works' Test Certificates that all items of electrical equipment comply with the relevant standard or Code of Practice are to be supplied.

3.8 Control equipment for the process plant

3.8.1 Details of the control system(s) are to be submitted, together with the following line diagrams and particulars:

- Line diagrams of any control system(s) fitted.
- General arrangement plan of the process plant showing the locations of items of control equipment and the locations of hazardous zones.
- Schedule of the parameters which are monitored and controlled, including alarms and shutdown devices.

3.9 Fire protection, detection and extinction

3.9.1 Plans of fire protection, detection and extinction arrangements, together with details of the fire and explosion hazards involved, are to be submitted.

■ Section 4 Materials

4.1 General

4.1.1 The materials used in the construction are to be manufactured and tested in accordance with the requirements of the *Rules for the Manufacture, Testing and Certification of Materials, July 2015* (hereinafter referred to as the Rules for Materials) and of *Chapter 6* of the Rules for Ships for Liquefied Gases, as applicable. Materials for which provision is not made in those requirements may be accepted, provided that they comply with an approved specification and such tests as may be considered necessary.

4.1.2 Materials of construction are to be suitable for the intended service, having regard to the substances, process and temperatures involved. For materials unsuitable for use with certain chemicals, and for the protection of materials, see *Materials of Construction and welding* of the Rules for Ships for Liquid Chemicals.

4.1.3 Details of the materials proposed for all types of construction are to be submitted for approval.

■ Section 5 Process plant characteristics

5.1 Design

5.1.1 The design and arrangements are to comply with the requirements of this Chapter and with relevant statutory regulations of the National Authority of the country in which the ship or structure is registered and/or in which it is to operate.

5.1.2 The process plant is to be designed for normal operation in accordance with recognised and agreed codes suitably modified to take into account the ship-borne environment in all its aspects. Except for emergency conditions, as detailed in *Pt 7, Ch 2, 3.1 General 3.1.3* or *Pt 7, Ch 2, 3.1 General 3.1.4*, the total stress in any component of the plant is not to exceed the code value at the temperature concerned, unless expressly agreed otherwise by LR, whether the plant is operative or non-operative, when subjected to any possible combination of the following loads:

- Static and dynamic loads due to wave-induced ship motions.
- Loads resulting from hull flexural effects at the plant support points.
- Direct wind loads.
- Normal process weights and pressures.
- Thermal loads.

Ships with Installed Process Plant for Chemicals, Liquefied Gases and Related Products

Part 7, Chapter 2

Section 6

5.1.3 For the emergency conditions in *Pt 7, Ch 2, 3.1 General 3.1.3* or *Pt 7, Ch 2, 3.1 General 3.1.4*, the stress levels are to be agreed with LR.

5.2 Separation from ship machinery

5.2.1 Where, during operation, process plant spaces contain or are likely to contain hazardous and/or toxic substances, they are to be kept separate and distinct from the main propulsion and auxiliary machinery and essential ship services, and also the power generating machinery for the process plant.

5.2.2 Notwithstanding the requirements of *Pt 7, Ch 2, 5.2 Separation from ship machinery 5.2.1*, this does not exclude the use of the ship's main, auxiliary and/or essential services, for process plant operation in suitable cases. Where, for reason of hazard, essential ship services have to be duplicated within the process plant space, they are to comply with the requirements of *Pt 7, Ch 2, 9 Pumping and piping systems for the process plant* and *Pt 5 Main and Auxiliary Machinery* and *Pt 6 Control, Electrical, Refrigeration and Fire*, as applicable.

Section 6 Hull construction

6.1 General

6.1.1 The hull structure is to comply with the relevant requirements of *Pt 3 Ship Structures (General)* and *Pt 4 Ship Structures (Ship Types)*, except as stated otherwise in this Section. The containment of liquefied gas products is to comply with *18, Ch 4 Cargo Containment* of the *18 Rules and Regulations for the Construction and Classification of Ships for the Carriage of Liquefied Gases in Bulk, July 2015*.

6.1.2 All chemical product and effluent tank structures and their location relative to the ship's hull are to comply with the *18 Rules and Regulations for the Construction and Classification of Ships for the Carriage of Liquefied Gases in Bulk, July 2015*, or with the *Rules and Regulations for the Construction and Classification of Ships for the Carriage of Liquid Chemicals in Bulk, July 2015*, as applicable. Where necessary, the probable temperature variations during operations and the thermal stress considerations are to be stated.

6.1.3 Materials for the hull structures subjected to low temperature are to comply with *Pt 3, Ch 2, 2.2 Refrigerated spaces* relating to refrigerated spaces and adjacent structures, or with *Chapter 6* of the Rules for Ships for Liquefied Gases, as applicable.

6.1.4 Subdivision and damage stability are not covered by these Rules. However, attention must be given to any relevant statutory regulations of the National Authority of the country in which the ship is to be registered or in which the plant is to be operated.

6.2 Location of accommodation, service and control spaces

6.2.1 All accommodation and other compartments not directly essential to the operation of the plant are to be arranged well clear of plant spaces, and feedstock and product tanks.

6.2.2 Service and control stations essential to the operation of the plant must be made 'gas-safe' in accordance with internationally accepted codes and standards, and should, wherever possible, be so located that access thereto is from a defined safe space. If such location is not possible, the station is to be specially ventilated.

6.3 Integrity of gastightness between compartments

6.3.1 Where integrity of gastightness is required between compartments containing the plant, this is to be maintained in way of pipe tunnels or duct keels where these traverse such compartments.

6.4 Cofferdams

6.4.1 Cofferdams are to be sited as required by the *18 Rules and Regulations for the Construction and Classification of Ships for the Carriage of Liquefied Gases in Bulk, July 2015*, or by the *Rules and Regulations for the Construction and Classification of Ships for the Carriage of Liquid Chemicals in Bulk, July 2015*, as applicable, segregating any spaces in which raw materials or products are stored or retained in bulk.

Ships with Installed Process Plant for Chemicals, Liquefied Gases and Related Products

Part 7, Chapter 2

Section 6

6.4.2 Cofferdams are to be arranged around independent tanks containing chemical products or effluents where these are separate from the ship structure, but permanently connected thereto. Such cofferdams are to be mechanically ventilated using portable or permanent systems as required by *Chapter 12* of the Rules for Ships for Liquid Chemicals, and are to be of sufficient size to allow effective inspection of all the tank and ship structure in way.

6.5 Access and openings to spaces

6.5.1 Access openings, windows, side scuttles and ventilation openings to accommodation, service and control stations essential for the operation of the ship, and similar safe spaces are to be located and arranged as required by the *18 Rules and Regulations for the Construction and Classification of Ships for the Carriage of Liquefied Gases in Bulk, July 2015*, or by the *Rules and Regulations for the Construction and Classification of Ships for the Carriage of Liquid Chemicals in Bulk, July 2015*, as applicable.

6.5.2 Arrangements are to be made to provide easy access to, or escape from, plant working spaces. In general, ladders are not to be arranged vertically, and intermediate platforms are to be fitted at vertical intervals of about 6 m. Ladders and platforms are to have guard rails and permanent provision made for attaching hoists for use in emergencies. The arrangements for the emergency hoists are to allow a clear, unobstructed lift to the outside deck.

6.5.3 Two separate means of access from the open deck are generally to be provided to the cofferdams required by *Pt 7, Ch 2, 6.4 Cofferdams 6.4.1*.

6.6 Longitudinal strength

6.6.1 Longitudinal strength calculations are to be made in accordance with *Pt 3, Ch 4 Longitudinal Strength* for the following conditions, and the Loading Manual required by *Pt 3, Ch 4, 8 Loading guidance information* is to include this information:

(a) **Sea-going conditions:**

These conditions are to take account of the weights and disposition of all ballast, plant items including any working fluids, other substances, spare gear, etc. and any special support bracing where thermal effects are considered, which will be on board during any sea-going condition of the plant appropriate to the category of ship.

(b) **Harbour condition:**

This condition is to take account of the weights and disposition of all ballast and plant items, including all working and other substances (in all intended stowage dispositions) and spare gear which will be on board during operation of the plant in harbour.

6.7 Plant support structure

6.7.1 Decks and other structure supporting the plant are, in general, to comply with the requirements of *Pt 3 Ship Structures (General)*. Such structure can, however, be considered on the basis of an agreed uniformly distributed loading in association with local loads at plant support points, provided that adequate transverse strength of the ship is maintained.

6.7.2 Where the nature and dispositions of heavy plant items are such that forces on the ship and support structure due to ship motions are significant (whether underway with or without working fluids, or moored with working fluids), calculations of the loading and the structural response are to be submitted. In this respect, the guidance formulæ for accelerations as given in the *18 Rules and Regulations for the Construction and Classification of Ships for the Carriage of Liquefied Gases in Bulk, July 2015* can be used where appropriate. Details of the mass distribution and support points of the plant items are to be submitted in all cases.

6.7.3 Where model tests or reliable direct calculation procedures are used to estimate wave-induced responses and which may indicate accelerations and motion amplitudes differing from those arising from the application of the Rules, such values will be taken into account in the approval of support structure.

6.7.4 If the vessel is intended for limited service at sea (e.g. a 'once only' voyage from port of build to service location), a reduction in the Rule accelerations and motion amplitudes may be permitted. In order to apply such a reduction, details of the intended service limitation should be submitted.

6.8 Loading due to wave-induced motions

6.8.1 In cases where the mass distribution of large columnar plant items is such that the centre of action of the dynamic force differs significantly from the centre of gravity of the item, due account of this is to be taken in the calculation of the forces and moments at the support positions.

Ships with Installed Process Plant for Chemicals, Liquified Gases and Related Products

6.9 Additional loads

6.9.1 The structure supporting the plant is also to be capable of withstanding forces arising from the following:

- Wind loads (in all conditions of service and all categories of ships).
- The angle of static heel arising from the emergency condition referred to in *Pt 7, Ch 2, 3.1 General 3.1.3* or *Pt 7, Ch 2, 3.1 General 3.1.4*, as applicable.
- For a Category 1 A ship, a collision force acting on the tank corresponding to one-half of the weight of the item with or without working fluids, as appropriate, to the approved sea-going conditions from forward and one-quarter of the weight of the item from aft.
- For all other categories of ship, a collision force from any horizontal direction of one-fifth of the weight of the item.

6.9.2 Wind loading, which is to be applied to the plant items and supporting structure protruding above the weather deck, should be considered to act simultaneously with wave-induced loading. Loadings *Pt 7, Ch 2, 6.9 Additional loads 6.9.1*, *Pt 7, Ch 2, 6.9 Additional loads 6.9.1* and *Pt 7, Ch 2, 6.9 Additional loads 6.9.1* need not be combined with wind loads or wave-induced loads.

6.10 Allowable stresses in support structure

6.10.1 The following stress levels are applicable in conjunction with the loading on the support structure:

- Support members above or below the weather deck which are not subject to main hull girder loading:

direct stress:

$$\sigma_a + \sigma_b = 0,6\sigma_y$$

shear stress:

$$\tau = 0,6\tau_y \text{ or } 0,35\sigma_y \text{ whichever is the smaller}$$

combined stress:

$$\sigma_c = 0,75 \sigma_y = \sqrt{(\sigma_a + \sigma_b)^2 + 3\tau^2}$$

where

$\sigma_a + \sigma_b$ = the algebraic sum of the axial and bending stresses at the point under consideration

σ_y = specified minimum tensile yield stress or 0,2 per cent proof stress at room temperature

τ_y = shear yield stress.

- Support members directly connected to hull structure and subject to transference of loading therefrom:
 - the maximum allowable direct, shear and combined stresses as defined in (a), but with member local loading increased by a factor of 1,30, or
 - when the stresses in such structure are determined using methods which satisfactorily take into account any ship deflection and load transference in way of supports, no load factor need be applied.
- Primary members forming an integral ship structural and plant support system:
 - in general, the allowable stresses in such a system will be especially considered on the basis of the degree of refinement employed in the load prediction, structural response and stress analysis methods. Structural response calculations should include the interaction effects of the hull and plant item.

6.10.2 In general, all seatings, platform decks, girders and pillars supporting plant items are to be arranged to align with the main hull structure, which is to be suitably reinforced, where necessary, to carry the appropriate loads. Attention should be paid to the capability of the support structure to withstand buckling.

6.11 Integrity of weather deck

6.11.1 The integrity of the weather deck is to be maintained. Where items of plant equipment penetrate the weather deck and are intended to constitute the structural barrier to prevent the ingress of water to spaces below the freeboard deck, their structural strength is to be equivalent to the Rule requirements for this purpose. Otherwise such items are to be enclosed in superstructures or deckhouses fully complying with the Rules. Full details are to be submitted for approval.

Ships with Installed Process Plant for Chemicals, Liquified Gases and Related Products

6.12 Equipment

6.12.1 Anchors and chain cables for ships navigating at sea are to comply with the requirements of *Pt 3, Ch 13, 7 Equipment*. Special consideration will be given to the equipment required for ships of Categories 1B and 2.

6.13 Gangways and freeing arrangements

6.13.1 Gangways are to be sufficient to provide proper access to all areas necessary for ship safety while the ship is operational and while it is at sea, and are to be to the Surveyor's satisfaction.

6.13.2 Freeing ports are to be fitted in accordance with the requirements of *Pt 3, Ch 8, 5.3 Freeing arrangements*.

■ Section 7

Mechanical equipment for the process plant

7.1 General

7.1.1 The requirements of this Section are applicable to all types of mechanical equipment associated with the process plant, with the exception of boilers and other pressure vessels.

7.1.2 The mechanical plant and equipment is to be designed and constructed in accordance with the relevant Sections of *Pt 5 Main and Auxiliary Machinery* and *Pt 6, Ch 3 Refrigerated Cargo Installations*, as applicable, and/or with agreed codes and specifications, suitably modified where necessary to suit shipboard conditions. The design is to be capable of accommodating the forces and moments stated in *Pt 7, Ch 2, 6.7 Plant support structure*, *Pt 7, Ch 2, 6.8 Loading due to wave-induced motions* and *Pt 7, Ch 2, 6.9 Additional loads*, as applicable, generated at the support points.

7.2 Safety precautions

7.2.1 Oil engines, air compressors and associated air starting piping, concerned with supplying services not essential to the safety of the vessel or structure, are to comply with the requirements of *Pt 5, Ch 2 Reciprocating Internal Combustion Engines*, where applicable.

7.2.2 Air intakes for internal combustion engines are to be led from a safe space. Where internal combustion engines, other than gas turbines, are used in association with plant processing flammable substances, the air intakes are to be fitted with an automatic device to prevent overspeeding in the event of accidental ingestion of flammable gases and/or vapours.

7.2.3 Exhaust pipes from internal combustion engines are to be led well clear of hazardous areas and, where such engines are used in association with plant processing flammable substances, are to be fitted with efficient spark arresters.

7.2.4 In general, air compressors are not to be installed in hazardous areas. Where this is not practicable, alternative arrangements may be accepted, provided that the air inlets are trunked or ducted from a safe space and that such trunking/ducting is fitted with gas detectors arranged to give audible and visible alarms and to shutdown the compressor in the event of flammable and/or toxic gas or vapour entering the air inlets.

7.2.5 The gas detectors are to be capable of continuously sampling the air supply and are to be so arranged as to prevent cross-communication between hazardous and safe spaces, such as control rooms, etc.

7.3 Inspection and installation

7.3.1 The scope of the inspection to be carried out at the manufacturers' works by the Surveyors is to be agreed before the work is commenced.

7.3.2 The mechanical plant and equipment are to be installed to the Surveyor's satisfaction. Proposals to site internal combustion engines in hazardous areas will be the subject of special consideration.

Ships with Installed Process Plant for Chemicals, Liquefied Gases and Related Products

Part 7, Chapter 2

Section 8

■ Section 8

Boilers and other pressure vessels for the process plant

8.1 General

8.1.1 The requirements of this Section are applicable to fired and unfired pressure vessels associated with the process plant.

8.1.2 The pressure vessels are to be made in accordance with the requirements of the relevant Sections of *Pt 5, Ch 10 Steam Raising Plant and Associated Pressure Vessels* or *Pt 7, Ch 2, 11 Electrical equipment for the process plant*, as applicable, or with agreed codes and specifications normally used for similar plant in land installations suitably modified and/or adapted for the marine environment. The design is to be capable of accommodating the forces and moments stated in *Pt 7, Ch 2, 6.7 Plant support structure*, *Pt 7, Ch 2, 6.8 Loading due to wave-induced motions* and *Pt 7, Ch 2, 6.9 Additional loads*, as applicable, generated at the support points.

8.1.3 Stress calculations are to take account of the emergency conditions in *Pt 7, Ch 2, 3.1 General 3.1.3* or *Pt 7, Ch 2, 3.1 General 3.1.4*, as applicable, in addition to the normal operational loadings. Due consideration is to be given to the effects of thermal expansion and contraction on the support points of the vessels.

8.2 Construction and installation

8.2.1 The pressure vessels are to be constructed, installed and tested to the Surveyor's satisfaction.

8.2.2 Suitable access is to be provided to the vessels for inspection, including checks on the operation of mountings, fittings, controls and pressure relief devices.

8.3 Safety devices

8.3.1 Where necessary, a test rig is to be supplied to enable the pressure setting of the safety and relief devices to be checked.

8.3.2 Where required, an additional pressure relieving device, with sufficient capacity (a) to prevent pressure vessels becoming liquid-full during fire engulfment and/or (b) to discharge vapours generated under fire exposure, is to be fitted in accordance with the relevant *18 Rules and Regulations for the Construction and Classification of Ships for the Carriage of Liquefied Gases in Bulk, July 2015*.

8.3.3 The arrangement of safety and relief discharges is to be such that there is no possibility of hazardous reaction between the substances involved.

8.3.4 Where provision is made for the isolation of safety relief devices from vessels and/or systems for maintenance purposes, not less than two such safety devices are to be fitted.

8.3.5 The isolating or blocking valves are to be so arranged that at least one safety relief device will remain in communication with the vessel or system under all conditions.

■ Section 9

Pumping and piping systems for the process plant

9.1 General

9.1.1 Arrangements are to be made in the process plant spaces, in order that substances which are flammable, toxic or are likely to present a hazard due to reaction when mixed are kept separate.

9.2 Process plant piping systems

9.2.1 Process plant piping systems are to be designed and constructed in accordance with agreed codes and specifications normally used for similar plants in land installations, suitably modified and/or adapted where necessary to suit the marine environment.

Ships with Installed Process Plant for Chemicals, Liquefied Gases and Related Products

Part 7, Chapter 2

Section 10

9.2.2 Sections of piping which may contain hazardous liquids or gases and which can be isolated are to be suitably protected, see Pt 7, Ch 2, 8.3 Safety devices 8.3.2.

9.3 Lubricating oil and fuel oil piping

9.3.1 Lubricating oil and fuel oil pipes, fittings, associated equipment, fuel oil burning arrangements and their materials of construction are to comply with the requirements of Pt 5, Ch 14 Machinery Piping Systems, where applicable.

9.4 Gas fuel supply systems

9.4.1 The gas fuel supply systems are to comply with the requirements of the relevant Sections of the 18 Rules and Regulations for the Construction and Classification of Ships for the Carriage of Liquefied Gases in Bulk, July 2015, where applicable.

9.4.2 Provision to shut off the gas is to be made in the gas firing supply lines immediately before the lines enter the compartment in which the equipment is installed. The shut-off arrangements are to be of the double block and vent type, and are to be operable at the equipment or the equipment control position and at a position in a safe area remote from the equipment.

9.5 Air and sounding pipes

9.5.1 Details of air and sounding pipes to tanks containing chemical products are to be submitted for approval.

9.6 Bilge and effluent arrangements

9.6.1 The arrangements for the storage on board ship, and the disposal of bilge and effluent from the process plant spaces, are to be submitted for consideration, and due recognition is to be given to the requirements of the appropriate National Authority.

9.6.2 Bilge and effluent pumping and piping systems in the process plant spaces are to be constructed of material suitable for the substances processed or produced or any combination of the substances which might result from accidental admixture.

9.6.3 Arrangements are to be provided for the control of the bilge and effluent pumping and piping system installed in the process plant spaces from within these spaces and also from a position outside the spaces.

9.6.4 The bilge and effluent pumping and piping systems handling hazardous materials should, wherever possible, be installed in the space associated with the particular hazard. Spaces containing pumps and piping systems that take their suction from a hazardous space may also be considered as hazardous spaces where a pipeline is not of an all-welded construction without flanges, valve glands and bolted connections, etc. and the pumps are not totally enclosed.

9.6.5 Where, during operation, process plant spaces contain or are likely to contain hazardous and/or toxic substances, they are to be kept separate and distinct from the ship's main bilge pumping and piping system. This does not, however, preclude the use of the ship's main bilge system when the process plant is shutdown, gas freed or otherwise made safe.

9.6.6 Pumping and piping systems for the ship services and process plant are to be constructed and installed to the Surveyor's satisfaction.

■ Section 10

Firing arrangements of steam boilers, fired pressure vessels, heaters, reformers, etc.

10.1 General

10.1.1 The requirements of this Section are applicable to all types of fired equipment associated with the process plant. The equipment is to be constructed, installed and tested to the Surveyor's satisfaction.

10.2 Design and construction

10.2.1 Details of the design and construction of the fuel gas burning equipment for steam boilers, oil and gas heater furnaces, reformers, etc. are to be in accordance with the 18 Rules and Regulations for the Construction and Classification of Ships for the Carriage of Liquefied Gases in Bulk, July 2015, or with agreed codes and specifications normally used for similar plants in land

Ships with Installed Process Plant for Chemicals, Liquefied Gases and Related Products

Part 7, Chapter 2

Section 11

installations, suitably modified and/or adapted for the marine environment. Ignition of the burners is to be by means of permanently installed igniters, or properly located and interlocked pilot burners and main burners arranged for sequential ignition.

10.2.2 Gas or gas/air mixtures having relative densities compared with that of air at the same temperature greater than one are not to be used as fuels for fired pressure vessels situated below deck. Proposals to burn such mixtures above deck will be specially considered in each case.

10.2.3 Proposals for the furnace purging arrangements prior to ignition of the burners are to be submitted. Such arrangements are to ensure that any accidental leakage of product liquid or gas into the furnace, from a liquid or gas heating element, or from the accidental ingestion of flammable gases and/or vapours, does not result in hazardous conditions.

10.2.4 Compartments containing fired pressure vessels, heaters, reformers, etc. for heating or processing hazardous substances are to be so arranged that the compartment in which the fired equipment is installed is maintained at a higher pressure than the combustion chamber of the equipment. For this purpose, induced draught fans or a closed stokehold system of forced draught may be employed. Alternatively, the fired equipment may be enclosed in a pressurised air casing.

10.2.5 The fired equipment is to be suitably lagged. The clearance spaces between the fired equipment and any tanks containing oil are to be not less than 760 mm. The compartments in which the fired equipment is installed are to be provided with an efficient ventilating system.

10.2.6 Smoke box and header box doors of fired equipment are to be well-fitting and shielded, and the uptake joints made gastight. Where it is proposed to install dampers in the uptake gas passages of fired equipment, the details are to be submitted. Dampers are to be provided with a suitable device whereby they may be securely locked in the fully open position.

10.2.7 Each item of fired equipment is to have a separate uptake to the top of the stack casing. Where it is proposed to install process fired equipment with separately fixed furnaces converging into a convection section common to two or more furnaces and/or a secondary radiant section at the confluence of the fired furnace uptake to the convection section, the proposed arrangements, together with the details of the furnace purging and combustion controls, are to be submitted.

■ Section 11 Electrical equipment for the process plant

11.1 Design of installation

11.1.1 Installations are to be designed in accordance with *Pt 6, Ch 2 Electrical Engineering*, or with a recognised National or International Standard or Code of Practice.

11.1.2 Attention must be given to any relevant statutory regulations of the National Authority of the country in which the ship is to be registered or in which the process plant is to be operated.

11.2 Equipment suitability for environment

11.2.1 Electrical equipment is to be constructed so that it is suitable for use in the environmental conditions envisaged, e.g. in areas of high ambient temperature, derating may be necessary.

11.3 Hazardous zones

11.3.1 Where flammable gases and vapours are involved, the defining of hazardous zones is to be in accordance with a National or International Standard or Code of Practice.

11.4 Certified safe-type equipment

11.4.1 Where safe-type equipment is permitted in hazardous zones, e.g.:

- Intrinsically-safe (symbol i),
- Flameproof (symbol d),
- Increased safety (symbol e),
- Pressurised enclosure (symbol p),

such equipment is to be certified for the gases and vapours involved. The construction and type testing are to be in accordance with IEC 60079: *Electrical Apparatus for Explosive Gas Atmospheres*, or an equivalent National Standard.

Ships with Installed Process Plant for Chemicals, Liquified Gases and Related Products

11.5 Survey and testing

11.5.1 All electrical equipment is to be installed and tested to the Surveyor's satisfaction.

■ Section 12 Control engineering for the process plant

12.1 Design of installation

12.1.1 Normal good engineering practice and standards are to be employed in any control system(s) fitted.

12.1.2 Due to the wide variety of types of process plant, it is not possible to lay down precise details of control scheme(s), since any control scheme is affected by the nature of, and the operating procedures of, the process plant. A description of the expected method of operation of the process plant is to be submitted.

12.2 Equipment

12.2.1 Control equipment is to be compatible with the materials involved in the plant process.

12.2.2 Where flammable gases or vapours are involved, control equipment located in hazardous zones is to be of certified safe-type.

12.3 Survey and testing

12.3.1 Control system(s) are to be installed and tested to the Surveyor's satisfaction.

■ Section 13 Plant blowdown systems

13.1 General

13.1.1 Where a liquid blowdown system is provided in the process plant, the design and installation are to make adequate provision for the effects of back pressure in the system and vapour flash off when the pressures of liquids in the blowdown system are reduced.

13.1.2 Substances which will react with each other are to be provided with separate systems.

■ Section 14 Plant flare gas systems

14.1 General

14.1.1 Details of any flare gas stack system and proposals for installation on board the ships, including safety arrangements, are to be submitted for consideration.

14.1.2 The protection zone around the nozzle of the flare gas stack is dependent upon the limiting radiation intensity under all conditions and, also, whether suitable radiation screens are provided. The flare gas stack is to be located so that the nozzle is situated not less than the radius of the protection zone or 50 m, whichever is the greater, from equipment and manned stations, etc.

14.1.3 The arrangements are to ensure that combustion of the flare gas is complete and safe at all times.

Ships with Installed Process Plant for Chemicals, Liquefied Gases and Related Products

■ Section 15

Supply and discharge arrangements for feedstock and product

15.1 General

15.1.1 Arrangements are to be made to isolate the ship from the supply of feedstock for processing, the supply of fuel oil or gas to boilers, heaters, etc. and the return flow of product, chemicals or process effluent, blow-down or flare gas, etc.

15.1.2 The arrangements are to provide for valves installed at the shore connection, where applicable, and on board ship which are to be operable from shut-off control and indicating stations on the ship, on the shore, and at the valves.

15.2 Emergency procedures

15.2.1 Detailed instructions of the emergency shutdown and evacuation procedure are to be posted in a prominent position at the ship and shore control stations, where applicable.

■ Section 16

Ventilation of the process plant and other spaces associated with the process plant operation

16.1 General

16.1.1 An efficient means of ventilation is to be provided for all enclosed compartments associated with the operation of the process plant.

16.1.2 The capacity of the ventilation systems is to comply with the requirements of *Pt 5, Ch 15, 1.7 Arrangements for fixed hydrocarbon gas detection systems in double hull and double bottom spaces of oil tankers* of the Rules for Ships for Liquefied Gases, or *Chapter 12* of the Rules for Ships for Liquid Chemicals, where applicable, or to an acceptable Code of Practice suitably modified and/or adapted where necessary to suit the marine environment. It is to be related to the hazard and/or environmental consideration of manned spaces during normal operation, and take into account additional requirements which may be necessary during start-up procedures.

16.2 Design and construction

16.2.1 Hazardous compartments where flammable and/or toxic substances are being processed or produced are to be arranged for underpressure ventilation, except as stated in *Pt 7, Ch 2, 10.2 Design and construction 10.2.4*.

16.2.2 Safe compartments, including control rooms, are to be arranged for overpressure ventilation.

16.2.3 The number and capacity of fans are to be such that the minimum ventilation capacity required in each compartment is maintained at all times, with one unit out of service. If internal combustion engines are proposed, their fuel supply is to be kept separate from any other system. Electric motors are to be supplied by two alternative circuits, each of which is capable of supplying all the motors which are normally connected to that circuit and which are operated simultaneously.

16.2.4 The mechanical ventilation system is to be capable of being controlled from a position outside the compartment being ventilated.

16.2.5 Reduction of ventilation capacity below the required level should be indicated in the compartment and also in the control room by an audible and visible alarm.

16.2.6 The parts of the rotating body and of the casing of each fan situated in a hazardous space are to be made of recognised spark-proof materials. If non-metallic materials are used, they are to have anti-static properties.

16.2.7 Ventilation trunking or ducting is to be suitably coated or painted, or made from material suitable for the substances processed or produced, or any combination of the substances which might result from accidental admixture.

16.3 Air inlets and discharges

16.3.1 The air inlets for the ventilation systems are to be located in a designated safe area.

Ships with Installed Process Plant for Chemicals, Liquefied Gases and Related Products

16.3.2 The air inlets and discharges of the ventilation system are to be so situated that recirculation of the vented vapours does not occur.

16.3.3 The discharges from ventilation systems which may contain vapours that present a hazard due to reaction with each other are to be effectively segregated.

16.3.4 The discharges from ventilation systems which may contain hazardous vapours are to be located not less than 10 m from the nearest air intake or opening to accommodation, service and control station spaces or other safe spaces, and from all possible sources of ignition.

16.3.5 Air intakes and openings into the accommodation spaces and all service and control station spaces are to be fitted with closing devices. For toxic gases, these devices are to be operable from inside the space.

16.3.6 Where it is impracticable to locate a plant service or control station so that any access thereto is from a safe space, the service or control station is to be maintained at an overpressure of not less than 5 mm water gauge above the surrounding spaces. Details of the arrangements to ensure that this pressure differential is maintained are to be submitted.

16.3.7 Airlocks for intercompartmental access doors and emergency escape trunks are to have separate ventilation systems so arranged that an overpressure of 5 mm water gauge is maintained above the adjacent compartments. Details of the arrangements to ensure that this pressure differential is maintained are to be submitted.

16.4 Installation and inspection

16.4.1 The ventilation systems are to be installed to the Surveyor's satisfaction.

16.4.2 The Surveyors are to be satisfied that the ventilation system is capable of maintaining a safe environment during process plant operation. This may require monitoring over an extended period to prove its effectiveness.

■ Section 17 Gas detection

17.1 General

17.1.1 An efficient gas detection system, suitable for the gases and/or vapours being processed or produced, and for the measurement of oxygen levels in the process plant compartments, is to be provided. Gas detector systems are also to comply with the requirements of *Pt 7, Ch 2, 17 Gas detection* or of *Chapter 13* of the Rules for Ships for Liquefied Gases, where applicable.

17.2 Design and construction

17.2.1 The equipment is to consist of a permanently fixed installation and at least two sets of portable equipment suitable for the process or products involved.

17.2.2 The position and number of fixed sampling points should be determined with due regard to the density of the gases and/or vapours of the substances processed or produced, and the dilution resulting from compartment ventilation. In each case, a sufficient number of sampling points is to be provided to give efficient selective sequential sampling to maintain a safe environment.

17.2.3 Unmanned or closed compartments, such as cofferdams, etc. associated with plant processing or producing flammable or toxic substances, are to have permanently installed sampling points suitable for use with portable detection equipment to be used before entry of the spaces by personnel and thereafter continuously while occupied by them.

17.2.4 Arrangements of the sampling point pipe runs are to be such that there is no possibility of hazardous gases and/or vapours entering a safe space. Common sampling lines to the detection equipment are not to be fitted.

17.2.5 The permanently installed gas detection system is to give audible and visible alarm, both in the control station and within the compartment, during hazardous conditions.

17.2.6 Except where continuous sampling is required (i.e. as in *Pt 7, Ch 2, 7.2 Safety precautions 7.2.5*), the gas detection equipment should be capable of sampling and analysing from each sampling point at agreed intervals, which are in no case to exceed 30 minutes.

Ships with Installed Process Plant for Chemicals, Liquefied Gases and Related Products

17.2.7 The gas detection equipment is to be designed so that it may be readily and regularly tested and calibrated. Suitable equipment and span gas is to be provided for this purpose. In addition, regular checking procedures with portable equipment are to be provided, particularly for closed or unmanned spaces during process plant operation.

17.2.8 Where equipment for detecting the specific flammable, toxic or asphyxiate substances which may be present in process plant spaces cannot be provided, full details are to be submitted, including personnel protection requirements and arrangements for decontaminating such spaces if necessary.

17.3 Installation

17.3.1 The gas detection system is to be installed to the Surveyor's satisfaction.

■ Section 18 Fire protection, detection and extinction

18.1 General

18.1.1 The requirements of SOLAS *Chapter II-2 - Construction - Fire protection, fire detection and fire extinction* and the *18 Rules and Regulations for the Construction and Classification of Ships for the Carriage of Liquefied Gases in Bulk, July 2015* are to be complied with, so far as they are applicable. Additional protection, consistent with the fire hazard involved, may be required for process plant control stations, and accommodation spaces. For the position of accommodation spaces relative to the process plant, see *Pt 7, Ch 2, 6.2 Location of accommodation, service and control spaces*.

18.1.2 Where the design of the process plant is such that it may be operated only while the vessel or floating structure is specially moored, anchored or otherwise linked close to the shore, consideration will be given to a shore-based fire-fighting facility, taking account of the particular hazards involved.

18.2 Design arrangements

18.2.1 Arrangements are to be made in enclosed process plant spaces to prevent contact of dangerously interreactive substances and of flammable materials with sources of ignition. In general, compartments containing process plant are not to exceed 40 m in length, and the boundary bulkheads are to be 'A' Class divisions.

18.2.2 Where, during operation, process plant spaces or adjacent hazardous zones contain or are likely to contain flammable and/or explosive mixtures, special consideration is to be given to the exclusion of all possible sources of ignition.

18.2.3 All heated surfaces, e.g. exhaust pipes, boiler uptakes and steam pipes, are to be effectively lagged or cooled, so that the maximum temperature, °C, of the surfaces is, in general, not to exceed 70 per cent of the auto-ignition temperature, °C, of any substances which may be present in the compartment. In no case is the difference in these temperatures to be less than 50°C.

18.2.4 Compartments where a fire hazard exists and which are not continuously manned are to be provided with an approved fire detection system which shall give visible and audible warning of the location of the fire in the control station and, for plant operating at sea (Category 1A), at the navigating bridge control position.

18.2.5 The fire main is to be so arranged, and hoses and nozzles provided, that any part of the compartments or structure associated with the process plant can be reached with two powerful jets of water, one of which shall be produced by a single length of hose. The hoses are to be provided with dual-purpose nozzles capable of producing a jet or a spray. Special consideration will be given to an exemption from this requirement in respect of compartments where the use of water would in itself constitute a hazard.

18.2.6 Each compartment where the fire hazard so demands is to be provided with an approved fixed fire-extinguishing system capable of extinguishing fires involving the materials present. Operation of such a system at its required output is not to prevent the simultaneous use of the required jets of water from the fire main. Where carbon dioxide systems and Halon systems are fitted, due consideration should be given to the danger of static electricity.

18.2.7 An adequate number of portable fire extinguishers are to be provided in each compartment where a fire hazard exists. The number of such extinguishers will be decided in relation to the nature of the hazard and the layout of the compartment, but shall not be less than two, one of which is to be positioned near the entrance. The extinguishing medium is to be considered in relation to the nature of the hazard involved.

Ships with Installed Process Plant for Chemicals, Liquified Gases and Related Products

Part 7, Chapter 2

Section 18

18.2.8 Means are to be provided for stopping all fans and, where practicable, closing all openings which might admit air to the compartment. Such means should be capable of being operated from a position outside the compartment and not likely to be rendered inaccessible by a fire in the compartment.

18.2.9 Means are to be provided for stopping the supply of combustible materials to the compartment in the event of fire.

18.2.10 The provision of additional fireman's outfits, each complying with the requirements of *10 Fire-fighter's outfits*, and the necessity for protective clothing, will be specially considered in relation to the layout of the process plant and the hazards involved.

Section

- 1 **General**
- 2 **Construction**
- 3 **Fire-extinguishing**
- 4 **Fire protection**
- 5 **Lighting**

■ **Section 1**
General

1.1 Application

1.1.1 The requirements of this Chapter apply to ships intended for fire-fighting operations and are additional to those applicable in other Parts.

1.1.2 A ship provided with fire protection and fire-fighting equipment in accordance with these Rules will be eligible for an appropriate class notation which will be recorded in the *Register Book*.

1.1.3 Requirements additional to these Rules may be imposed by the National Authority with whom the ship is registered and/or by the Administration within whose territorial jurisdiction the fire-fighting ship is intended to operate.

1.2 Classification and class notations

1.2.1 The class notations which may be assigned are:

- `Fire-fighting ship 1 (total monitor discharge capacity in brackets)`,
- `Fire-fighting ship 2 (total monitor discharge capacity in brackets)`,
- `Fire-fighting ship 3 (total monitor discharge capacity in brackets)`,
- `Fire-fighting ship 1 (total monitor discharge capacity in brackets) with water spray`,
- `Fire-fighting ship 2 (total monitor discharge capacity in brackets) with water spray`,
- `Fire-fighting ship 3 (total monitor discharge capacity in brackets) with water spray`.

1.2.2 The notation **Fire-fighting ship 1**, **Fire-fighting ship 2** or **Fire-fighting ship 3** signifies that a ship complies with these Rules and is provided with the appropriate fire-fighting equipment described in *Table 3.1.1 Fire-fighting equipment*, with the total discharge capacity of monitors in m³/h shown in brackets.

1.2.3 The addition of the words `with water spray` to the notations referred to in *Pt 7, Ch 3, 1.2 Classification and class notations 1.2.1* signifies that a ship is provided with a water spray system, which will provide an effective cooling spray of water over the vertical surfaces of the ship to enable it to approach a burning installation for fire-fighting purposes. The requirements for such a system are set out in *Pt 7, Ch 3, 4.2 Water spray systems*.

Table 3.1.1 Fire-fighting equipment

Equipment	Fire-fighting ship		
	1	2	3
Minimum total pump capacity, m ³ /h	2400	7200	10 000
Minimum number of water monitors	2	3	4
Minimum discharge rate per monitor, m ³ /h	1200	1800	1800
Minimum height of trajectory of jets of monitors above sea level, metres	45	70	70

Minimum range of monitor jets, m	120	150	150
Minimum fuel capacity for monitors, hours	24	96	96
Number of hose connections each side of ship	4	8	8
Number of fireman's outfits	4	8	8

1.3 Surveys

1.3.1 The arrangements and equipment referred to in this Chapter are to be examined and tested under working conditions on completion of the installation and, subsequently, annually.

1.4 Submission of plans

1.4.1 The following plans and information are to be submitted:

- A general arrangement showing the disposition of all fire-fighting equipment required by this Chapter.
- Details of major items of fire-fighting equipment such as pumps and monitors, including their capacity, range and trajectory of delivery.
- A general arrangement plan showing the disposition of fire divisions and their class.
- Detailed plans of the fire divisions and, where applicable, copies of the certificates of approval for the insulating materials proposed.
- A plan of the construction of the fire doors.
- Plans showing the layout and capacity of the water spray system. Where alternative arrangements to those specified in *Pt 7, Ch 3, 4.2 Water spray systems* are proposed, evidence is to be submitted to satisfactorily demonstrate that an equivalent level of protection from radiated heat is provided, including details of the environmental conditions in which the ship is intended to operate, see *Pt 7, Ch 3, 4.2 Water spray systems 4.2.1*.
- A plan of the seating arrangements for the water monitors.
- Particulars of the means of keeping the ship in position during fire-fighting operations.
- A plan showing the fire pumps, the fire water main, the hydrants, hoses and hose nozzles and the monitors together with particulars of their delivery capability.
- Details of the fireman's outfits provided.
- Plans of any other fire-fighting systems provided.

1.5 Definitions

1.5.1 'A-60 standard' means a fire-resisting construction of steel or other equivalent material, which is suitably stiffened and so constructed as to be capable of preventing the passage of smoke and flame for the complete period of the one-hour standard fire test. It is to be insulated with approved non-combustible materials, so that the average temperature on the unexposed side will not rise by more than 139°C above the original temperature, nor will the temperature at any one point, including any joint, rise more than 180°C above the original temperature within 60 minutes.

1.5.2 'Steel or other equivalent material'. In this context 'equivalent material' means any material which, by itself or due to insulation provided, has structural and integrity properties equivalent to steel at the end of the applicable standard fire test exposure period (e.g. aluminium with appropriate insulation).

1.5.3 'The standard fire test' is one in which specimens of the relevant bulkheads or decks, having a surface area of approximately 4,65 m² and a height of 2,44 m, resembling as closely as possible the intended construction and including, where appropriate, at least one joint, are exposed in a test furnace to heat on a time-temperature relationship, approximately as follows:

- At the end of the first 5 minutes, 538°C.
- At the end of the first 10 minutes, 704°C.
- At the end of the first 30 minutes 843°C.
- At the end of the first 60 minutes 927°C.

1.5.4 A 'non-combustible material' means a material which neither burns nor gives off flammable vapours in sufficient quantity for self-ignition when heated to approximately 750°C. Any other material is a 'combustible material'.

■ Section 2 Construction

2.1 Hull

2.1.1 The structure of the ship is to be strengthened as necessary to withstand the forces imposed by the fire-extinguishing systems when operating at their maximum capacity.

2.2 Sea suctions

2.2.1 The sea suctions of the fire pumps are to be arranged as low as practicable in the ship's structure to avoid icing or the ingress of oil from the surface of the sea.

2.2.2 All sea inlet valves are to be provided with a low pressure steam or compressed air connection for clearing purposes.

2.3 Stability

2.3.1 Each ship is to comply with the draught and stability requirements of the National Authority and is to have on board sufficient stability data to enable the ship to be properly loaded and handled. This data is to take full account of the effect of the monitors when they are operating at their maximum output in all possible directions of use.

2.4 Manoeuvrability

2.4.1 Arrangements are to be provided to enable the ship to maintain position, so that the monitors may be effectively deployed.

2.5 Bunkering

2.5.1 The Owner should ensure that any fuel which may be required while the ship is operating on station can be safely received on board.

■ Section 3 Fire-extinguishing

3.1 Water monitors

3.1.1 The minimum number of monitors, their discharge rate, their range and their height of trajectory above sea level are to comply with the requirements of *Table 3.1.1 Fire-fighting equipment*.

3.1.2 The monitors are to be so arranged that the required direction, range and height of trajectory can be achieved separately, with the required number of monitors operating simultaneously.

3.1.3 The monitors are to be capable of adequate adjustment in the vertical and horizontal direction and are to be so positioned that the jets will be unimpeded within the required range of operation.

3.1.4 Means are to be provided for preventing the monitor jets from impinging on the ship's structure and equipment when in external fire fighting mode. Combined systems for high pressure external fire fighting and deck foam fire fighting may be permitted provided consideration is given to monitor position and to the safety of operating pressures when used in deck foam mode and during changeover between modes. Change over between modes is to be by a simple operator action. The combined system is to be capable of simple and rapid operation in either mode.

3.1.5 The monitors are to be capable of being activated and manoeuvred by remote control from a protected position providing a good view of the monitors and the operating area of the water jets.

3.1.6 The monitors are to be of robust construction and their seating arrangements are to be of adequate strength for all modes of operation, particular attention being paid to shock loading when all the monitors are activated simultaneously.

3.1.7 For the class notations **Fire-fighting ship 2** and **Fire-fighting ship 3**, an arrangement with one less monitor than required in *Table 3.1.1 Fire-fighting equipment* may be considered as an equivalent solution. In such cases the total pump capacity

is to be as required in *Table 3.1.1 Fire-fighting equipment*. The minimum range of monitor jets and minimum height of trajectory of jets of monitors above sea level are to be 180 m and 110 m, respectively.

3.2 Pumps

3.2.1 The pumps and their piping system which are intended for serving the monitors are not to be available for services other than fire-extinguishing and water spraying. Each pump is to be provided with a dedicated independent sea chest.

3.2.2 Where the pumps are used for fixed water spray systems, the piping is to be independent of that supplying the monitors. The water spray systems are to be adequately protected against overpressure.

3.2.3 The minimum total pump capacities required are shown in *Table 3.1.1 Fire-fighting equipment*.

3.2.4 For assignment of the notations **Fire-fighting ship 2** or **Fire-fighting ship 3** there are to be at least two pumps serving the monitors and they should be of approximately equal capacity. For assignment of the notation **Fire-fighting ship 1** one pump only need be provided.

3.3 Hose stations

3.3.1 Hose stations are to be provided on each side of the ship in accordance with *Table 3.1.1 Fire-fighting equipment*.

3.3.2 Each hose station is to be provided with a hydrant, a hose and a nozzle capable of producing a jet or a spray and simultaneously a jet and a spray. The hoses are to be 15 m in length and not less than 38 mm nor more than 65 mm in diameter. Where hose stations are connected to the monitor supply lines, provision is to be made to reduce the water pressure at the hydrants to an amount at which each fire hose nozzle can be safely handled by one man. The water pressure shall be sufficient to produce a water jet throw of at least 12 m.

3.4 Fireman's outfits

3.4.1 The number of fireman's outfits provided, in addition to those provided in accordance with *Pt 6, Ch 4, 2 Fire detection, protection and extinction* or SOLAS Reg. II-2/C, *10 Fire-fighter's outfits* as applicable is to be in accordance with *Table 3.1.1 Fire-fighting equipment*. They are to be stored in a safe position which is readily accessible from the open deck.

3.4.2 The composition of a fireman's outfit is to be as follows:

- Protective clothing of material to protect the skin from heat radiating from the fire and from burns and scalding by steam. The outer surface is to be water-resistant.
- Boots and gloves of rubber or other electrically non-conducting material.
- A rigid helmet providing effective protection against impact.
- An electric safety lamp (hand lantern) of an approved type with a minimum operating period of three hours.
- An axe having an insulated handle.
- A self-contained breathing apparatus, which is to be capable of functioning for a period of at least 30 minutes and having a capacity of at least 1200 litres of free air. Spare, fully charged air bottles are to be provided at the rate of at least one set per required apparatus.
- For each breathing apparatus, a fireproof lifeline of sufficient length and strength is to be provided capable of being attached by means of a snaphook to the harness of the apparatus or to a separate belt, in order to prevent the breathing apparatus becoming detached when the life-line is operated.

3.5 Recharging of equipment

3.5.1 A suitable air compressor for recharging the bottles used in the breathing apparatus of the fireman's outfits is to be provided. It is to be capable of recharging the bottles of the breathing apparatus required to be carried, in accordance with *Table 3.1.1 Fire-fighting equipment*, in a time not exceeding 30 minutes.

■ *Section 4* **Fire protection**

4.1 General

4.1.1 In ships which are not provided with a water spray system as described in *Pt 7, Ch 3, 4.2 Water spray systems* all windows and port lights are to be provided with efficient deadlights or external steel shutters, except in the wheelhouse.

4.2 Water spray systems

4.2.1 Ships which are intended to operate in close proximity to a large fire will require protection from the heat radiated from the fire. Such protection may be afforded by a system which provides a water spray over the surface of the ship, or by a combination of insulation and a water spray system. Alternative arrangements providing an equivalent level of protection may be accepted where it can be demonstrated that such arrangements are effective for the environmental conditions in which the ship is intended to operate.

4.2.2 The water spray system is to be a fixed system which is capable of delivering a spray of water over all the exposed external vertical surfaces of the hull in the lightest sea-going condition, including the superstructures and deckhouses and over the monitor position. The water spray system will also be required to cover the areas of deck which form the crowns of machinery spaces and other spaces containing combustible materials.

4.2.3 The system is to have a capacity of 10 litres/min per m² of the protected area of uninsulated steel and 5 litres/min per m² of the protected area which is insulated internally to A-60 standard.

4.2.4 The system may be divided into sections, so that it will be possible to enable the closing down of those sections covering surfaces which are not exposed to radiant heat.

4.2.5 The nozzles are to be arranged to give an even distribution of water spray over the protected area.

4.2.6 The pumping capacity is to be sufficient to supply simultaneously at the required pressure the sections which serve the maximum area which may be exposed to radiant heat from a fire. If the main fire pumps are used for this purpose, they are to be capable of operating this system and the monitors and hose stations simultaneously at the required pressures, *see also Pt 7, Ch 3, 3.2 Pumps 3.2.2.*

4.2.7 Deck scuppers and freeing ports are to be of sufficient area to ensure efficient drainage of water from decks and horizontal surfaces in all conditions when the water spray system is in operation.

■ *Section 5* **Lighting**

5.1 General

5.1.1 Two searchlights should be provided for illuminating the burning structure and facilitate the effective deployment of the water monitors at night.

5.1.2 The searchlights are to be capable of providing at a range of 250 m in clear atmospheric conditions a level of illumination of 50 lux within an area of not less than 11 m diameter. They are to be capable of being adjusted in the horizontal and vertical directions.

Section

-
- 1 **General**
 - 2 **Class notation DP(CM)**
 - 3 **Class notation DP(AM)**
 - 4 **Class notation DP(AA)**
 - 5 **Class notation DP(AAA)**
 - 6 **Performance Capability Rating (PCR)**
 - 7 **Testing**
-

■ **Section 1**
General

1.1 Application

1.1.1 The requirements of this Chapter apply to ships with installed dynamic positioning systems and are additional to those applicable in other Parts of these Rules.

1.1.2 A ship provided with a dynamic positioning system in accordance with these Rules will be eligible for an appropriate class notation which will be recorded in the *Register Book*.

1.1.3 Requirements, additional to these Rules may be imposed by the National Administration with whom the ship is registered and/or by the administration within whose territorial jurisdiction it is intended to operate. Where national legislative requirements exist, compliance with such regulations shall also be necessary.

1.1.4 For the purpose of these Rules, dynamic positioning means the provision of a hydrodynamic system with automatic and/or manual control capable of maintaining the heading and position of the ship during operation within specified limits and environmental conditions.

1.1.5 For the purpose of these Rules, the area of operation is the specified allowable position deviation from a set point, see *Pt 7, Ch 4, 1.3 Information and plans required to be submitted 1.3.2*.

1.1.6 Special consideration will be given where the dynamic positioning system is used primarily for purposes other than position keeping, e.g. track following. A descriptive note may be entered in column 6 of the *Register Book* to this effect.

1.2 Classification notations

1.2.1 Ships complying with the requirements of this Chapter will be eligible for one of the following class notations, as defined in *Pt 1, Ch 2 Classification Regulations*:

- (a) **DP(CM)** See *Pt 7, Ch 4, 2 Class notation DP(CM)*.
- (b) **DP(AM)** See *Pt 7, Ch 4, 3 Class notation DP(AM)*.
- (c) **DP(AA)** See *Pt 7, Ch 4, 4 Class notation DP(AA)*.
- (d) **DP(AAA)** See *Pt 7, Ch 4, 5 Class notation DP(AAA)*.

1.2.2 The notations given in *Pt 7, Ch 4, 1.2 Classification notations 1.2.1* may be supplemented with a Performance Capability Rating (**PCR**). This rating indicates the calculated percentage of time that a ship is capable of maintaining heading and position under a standard set of environmental conditions (North Sea), see *Pt 7, Ch 4, 6 Performance Capability Rating (PCR)*.

1.2.3 Additional descriptive notes may be entered in column 6 of the *Register Book* indicating the type of position reference system, control system, etc.

1.2.4 Where a **DP** notation is not requested, dynamic positioning systems are to be installed in accordance with the requirements of *Pt 7, Ch 4, 2 Class notation DP(CM)* as far as is practicable.

1.3 Information and plans required to be submitted

1.3.1 The information and plans specified in *Pt 7, Ch 4, 1.3 Information and plans required to be submitted 1.3.2* to *Pt 7, Ch 4, 1.3 Information and plans required to be submitted 1.3.7* are to be submitted in triplicate. The Operation Manuals specified in *Pt 7, Ch 4, 1.3 Information and plans required to be submitted 1.3.9* are to be submitted in a single set.

1.3.2 Details of the limits of the area of operation and heading deviations, together with proposals for redundancy and segregation provided in the machinery, electrical installations and control systems, are to be submitted. These proposals are to take account of the possible loss of performance capability should a component fail or in the event of fire or flooding, see *also Pt 7, Ch 4, 1.3 Information and plans required to be submitted 1.3.6* and *Pt 7, Ch 4, 4 Class notation DP(AA)* and *Pt 7, Ch 4, 5 Class notation DP(AAA)*.

1.3.3 Where a common power source is utilized for thrusters, details of the total maximum load required for dynamic positioning are to be submitted.

1.3.4 Plans of the following, together with particulars of ratings in accordance with the relevant Parts of the Rules, are to be submitted for:

- (a) Prime movers, gearing, shafting, propellers and thrusters.
- (b) Machinery piping systems.
- (c) Electrical installations.
- (d) Pressure vessels for use with dynamic positioning system.

1.3.5 Plans of control, alarm and safety systems, including the following, are to be submitted:

- (a) Functional block diagrams of the control system(s).
- (b) Functional block diagrams of the position reference systems and the environmental sensors.
- (c) Details of the electrical supply to the control system(s), the position reference system(s) and the environmental sensors.
- (d) Details of the monitoring functions of the controllers, sensors and reference systems, together with a description of the monitoring functions.
- (e) List of equipment with identification of the manufacturer, type and model.
- (f) Details of the control stations, e.g. control panels and consoles, including the location of the control stations.
- (g) Test schedules (for both works testing and sea trials) that are to include the methods of testing and the test facilities provided.

1.3.6 For assignment of **DP(AA)** or **DP(AAA)** notation, a Failure Mode and Effects Analysis (FMEA) is to be submitted, demonstrating that adequate segregation and redundancy of the machinery, the electrical installation and the control systems have been achieved in order to maintain position in the event of equipment failure (see *Pt 7, Ch 4, 4 Class notation DP(AA)*); or fire or flooding, see *Pt 7, Ch 4, 5 Class notation DP(AAA)*. The FMEA is to take a formal and structured approach and is to be performed in accordance with an acceptable and relevant national or international standard, e.g. IEC 60812.

1.3.7 Where the DP notation is to be supplemented with a Performance Capability Rating (**PCR**) (see *Pt 7, Ch 4, 1.2 Classification notations 1.2.2*), the following information is to be submitted for assignment of a PCR:

- (a) Lines plan.
- (b) General arrangement.
- (c) Details of thruster arrangement.
- (d) Thruster powers and thrusts.

1.3.8 Details of the intended modes of operation are to be submitted. As a minimum, these are to include:

- (a) a description of all the intended operating modes;
- (b) details of the system configuration required for each mode of operation. When applicable, this is to include the configuration needed to meet the FMEA requirements of *Pt 7, Ch 4, 1.3 Information and plans required to be submitted 1.3.6*; and
- (c) the procedures which are to be followed in each operating mode during normal and abnormal conditions.

1.3.9 A set of the operation and maintenance manuals is to be placed and retained on board the ship.

■ **Section 2**
Class notation DP(CM)

2.1 General

2.1.1 For assignment of **DP(CM)** notation, the requirements of *Pt 7, Ch 4, 2.1 General 2.1.2* and *Pt 7, Ch 4, 2.2 Thrusters to Pt 7, Ch 4, 2.5 Control system* are to be complied with.

2.1.2 Control engineering systems, electrical and piping installations and machinery items are to be designed, constructed, installed and tested in accordance with the relevant requirements of *Pt 5 Main and Auxiliary Machinery* and *Pt 6 Control, Electrical, Refrigeration and Fire*.

2.2 Thrusters

2.2.1 Thruster installations are to be designed, constructed, installed and tested in accordance with the requirements of *Pt 5, Ch 20 Azimuth Thrusters*, as applicable.

2.2.2 Thruster installations are to be designed to minimize potential interference with other thrusters, sensors, hull or other surfaces, which could be encountered in the service for which the ship is intended.

2.2.3 Thruster intakes are to be located at sufficient depth to reduce the possibility of ingesting floating debris and vortex formation.

2.2.4 The response and repeatability of thrusters to changes in propeller pitch or propeller speed/direction of rotation are to be suitable for maintaining the area of operation and heading within specified limits.

2.3 Electrical systems

2.3.1 This Section applies to the electrical generation and distribution system associated with the Dynamic Positioning System, whether this generating system is dedicated to the DP system or forms a central generating arrangement for all loads on the ship.

2.3.2 The electrical installation is to be designed, constructed and installed, in accordance with the requirements of *Pt 6, Ch 2 Electrical Engineering*, together with the requirements of *Pt 7, Ch 4, 2.3 Electrical systems 2.3.3* to *Pt 7, Ch 4, 2.3 Electrical systems 2.3.12*.

2.3.3 Where thrusters are electrically driven, the relevant requirements, including surveys, of *Pt 6, Ch 2, 16 Electric propulsion* are to be complied with.

2.3.4 Essential services are those defined in *Pt 6, Ch 2, 1.6 Definitions*, as applicable, together with thruster auxiliaries, computers, generator and thruster control equipment, reference systems, environmental sensors and electrically driven thrusters.

2.3.5 The number and rating of generator sets, transformers and converter equipment are to be sufficient to ensure the operation of essential services, even when one generating set, transformer or converter equipment is out of action.

2.3.6 For electrically driven thruster systems, the generator rating is to be determined by the maximum dynamic positioning load, together with the maximum ancillary load.

2.3.7 There are to be arrangements to prevent overloading of the running generator(s). The tripping of non-essential loads and the temporary reduction in the load demands of electrically driven thrusters may form part of these arrangements.

2.3.8 An alarm is to be initiated when the total electrical load exceeds a preset percentage of the running generator(s) capacity. This alarm is to be adjustable between 50 and 100 per cent of the running capacity and is to be set with regard to the number of generators in service and the effect of the loss of any one generator.

2.3.9 On loss of power due to the failure of the operating generator(s), there is to be provision for the automatic starting and connection to the switchboard of a standby set and the automatic sequential restarting of essential services. Consideration may be given to cases where arrangements for automatic re-starting of thrusters would not be practicable. Details are to be submitted in such cases to show that manual means for the immediate re-starting of thrusters would be available at the control station from where the dynamic positioning system would be operated.

2.3.10 Any loads that require an uninterrupted electrical power supply are to be provided with uninterruptible power systems (UPS) having a capacity for a minimum of 30 minutes' operation following loss of the main supply. A UPS is to be provided for each control computer system.

2.3.11 An indication of the absorbed power and the available on-line generating capacity is to be provided at the main dynamic positioning control station.

2.3.12 Essential services are to be served by individual circuits. Essential services that are duplicated are:

- (a) to be supplied from independent sections of their switchboard or section board;
- (b) to have their circuits separated throughout their length as widely as is practicable; and
- (c) not to depend upon common feeders, transformers, converters, protective devices, control circuits or controlgear assemblies to operate.

2.4 Control stations

2.4.1 Control stations from which the dynamic positioning system may be operated are to be designed in accordance with sound ergonomic principles, and are to be provided with sufficient instrumentation to provide effective control and indicate that the systems are functioning correctly. Colour schemes and screen layouts are to be selected such that necessary information is readily available and clearly displayed. See also *Pt 6, Ch 1, 2.10 Programmable electronic systems - General requirements* for general ergonomic requirements.

2.4.2 Control station(s) are to be located such that the operator has a good view of the ship's exterior limits and surrounding area.

2.4.3 Indication of the following is to be provided at each station from which it is possible to control the dynamic positioning system:

- (a) The heading and location of the ship relative to the desired reference point or course.
- (b) Vectorial thrust output, individual and total.
- (c) Operational status of position reference systems and environmental sensors.
- (d) Environmental conditions, e.g. wind speed and direction.
- (e) Availability status of standby thrusters.

2.4.4 At least one position reference system, heading reference sensor and wind sensor are to be provided to ensure that the specified area of operation and heading can be effectively maintained.

2.4.5 Position reference systems are to incorporate measurement techniques suitable for the service conditions for which the ship is intended.

2.4.6 Where necessary for the correct functioning of a position reference system, a vertical reference sensor is to be provided to correct for the pitch and roll of the ship. There are to be at least as many vertical reference units as there are associated position reference systems.

2.4.7 Alarms, in accordance with the requirements of *Pt 6, Ch 1, 2.3 Alarm systems, general requirements*, are to be provided for the following fault conditions as applicable:

- (a) When the ship deviates from the area of operation.
- (b) When the heading exceeds the allowable deviation.
- (c) Position reference system fault (for each reference system).
- (d) Heading reference sensor fault.
- (e) Vertical reference sensor fault.
- (f) Wind sensor fault.
- (g) Taut wire excursion limit.
- (h) Automatic changeover to a standby position reference system or environmental sensor.

A permanent record of the occurrences of alarms and warnings, and of status changes is to be provided.

2.5 Control system

2.5.1 A centralised remote manual control system is to be provided such that changes in the vectorial thrust output may be readily effected by a single operator action.

2.5.2 Suitable processing and comparative techniques are to be provided to validate the control system inputs from position and other sensors. Abnormal signal errors revealed by the validity checks are to operate alarms.

2.5.3 The control system for dynamic positioning operation is to be stable throughout its operational range and is to meet the specified performance and accuracy criteria.

2.5.4 Automatic controls are to be provided to maintain the heading of the ship within specified limits.

2.5.5 The allowable deviation from the desired heading is to be adjustable, but should not exceed the specified limits, see *Pt 7, Ch 4, 1.1 Application 1.1.4*. Arrangements are to be provided to fix and identify the set point for the desired heading.

2.5.6 Alarms, in accordance with the requirements of *Pt 6, Ch 1, 2.3 Alarm systems, general requirements*, are to be provided for the following fault conditions:

- (a) Control computer system fault.
- (b) Automatic changeover to a standby control computer system, as applicable, see *Pt 7, Ch 4, 4.1 Requirements 4.1.8*.

■ Section 3

Class notation DP(AM)

3.1 Requirements

3.1.1 For assignment of **DP(AM)** notation the applicable requirements of *Pt 7, Ch 4, 2 Class notation DP(CM)* together with *Pt 7, Ch 4, 3.1 Requirements 3.1.2 to Pt 7, Ch 4, 3.1 Requirements 3.1.6*, are to be complied with.

3.1.2 An automatic and a manual control system are to be provided and arranged to operate independently, so that failure in one system will not render the other system inoperative. Arrangements for manual control are to satisfy the requirements of *Pt 7, Ch 4, 2 Class notation DP(CM)* when the automatic system is inoperative.

3.1.3 At least two position reference systems suitable for the intended service conditions and incorporating different measurement techniques, are to be provided and arranged, so that a failure in one system will not render the other system inoperative. Special consideration will be given where the use of different techniques would not be practicable during DP operations.

3.1.4 At least two heading reference sensors and two wind sensors are to be provided and arranged, so that a failure of one sensor will not render the other sensor(s) inoperative.

3.1.5 In the event of a single failure of a position reference, heading reference, or wind sensor, the control systems are to continue operating on signals from the remaining sensors without manual intervention.

3.1.6 The area of operation is to be adjustable, but is not to exceed the specified limits based on a percentage of water depth, or as applicable, a defined absolute or relative surface movement. Arrangements are to be provided to fix and identify the set point for the area of operation .

■ Section 4

Class notation DP(AA)

4.1 Requirements

4.1.1 For assignment of **DP(AA)** notation, the applicable requirements of *Pt 7, Ch 4, 2 Class notation DP(CM)* and *Pt 7, Ch 4, 3 Class notation DP(AM)*, together with *Pt 7, Ch 4, 4.1 Requirements 4.1.2 to Pt 7, Ch 4, 4.1 Requirements 4.1.11* are to be complied with.

4.1.2 Power, control and thruster systems and other systems necessary for, or which could affect, the correct functioning of the DP system are to be provided and configured such that a fault in any active component or system will not result in a loss of position. This is to be verified by means of a FMEA, see *Pt 7, Ch 4, 1.3 Information and plans required to be submitted 1.3.6*. Such components may include, but are not restricted to, the following:

- Prime movers (e.g. auxiliary engines).
- Generators and their excitation equipment.
- Gearing.
- Pumps.
- Fans.

- Switchgear and controlgear, including their assemblies.
- Thrusters.
- Valves (where power actuated).

Systems which are not part of the DP system but which, in the event of a fault, could affect the correct functioning of the DP system (for example, fire suppression systems, engine ventilation systems, shutdown systems, etc.) are to be included in the FMEA.

4.1.3 Cables, pipes and other components essential for correct functioning of the DP system are to be located and protected, where necessary, such that the risk of fire or mechanical damage is minimised.

4.1.4 The electrical generation and distribution arrangements are to be isolatable such that at least the minimum number of any duplicated, or otherwise replicated, items required to provide essential services would remain operational in the event of a single fault. Evidence to verify compliance with this requirement is to be submitted for consideration when required; for example, where it is intended to operate with the independent sections required by *Pt 7, Ch 4, 2.3 Electrical systems 2.3.12* connected together.

4.1.5 Where the independent switchboards or section boards required by *Pt 7, Ch 4, 2.3 Electrical systems 2.3.12* are to be connected together, this is to be via two multipole circuit-breakers connected in series. Where alternative arrangements are proposed, these may be accompanied by a technical justification showing compliance with *Pt 7, Ch 4, 4.1 Requirements 4.1.4*.

4.1.6 For electrically driven thruster systems:

- a reduction in position keeping capability may be accepted, but this is not to result in a loss of position in the environmental conditions in which the DP system is intended to operate; and
- provision is to be made for the automatic starting, synchronising and load sharing of a non-running generator before the load reaches the alarm level required by *Pt 7, Ch 4, 2.3 Electrical systems 2.3.8*.

4.1.7 Two automatic control systems are to be provided and arranged to operate independently, so that failure in one system will not render the other system inoperative.

4.1.8 Control systems are to be arranged such that, in the event of failure of the working control system, the standby system takes control automatically without manual intervention and without any adverse effect of the ship's station keeping performance.

4.1.9 At least three position reference systems incorporating at least two different measurement techniques are to be provided and arranged so that a failure in one system will not render the other systems inoperative.

4.1.10 At least three heading reference sensors are to be provided and arranged so that a failure of one sensor will not render the other sensors inoperative.

4.1.11 The DP system is to incorporate a computer based consequence analysis to determine whether the position of the vessel would remain within the limits set by the operator in the event of a worst case fault. An audible and visual alarm is to be initiated where the consequence analysis determines that the limits would be exceeded. Where applicable to the timescale for safely terminating operations, the consequence analysis is to allow for manual input of predicted environmental conditions.

■ Section 5

Class notation DP(AAA)

5.1 Requirements

5.1.1 For assignment of **DP(AAA)** notation, the applicable requirements of *Pt 7, Ch 4, 2 Class notation DP(CM)*, *Pt 7, Ch 4, 3 Class notation DP(AM)* and *Pt 7, Ch 4, 4 Class notation DP(AA)*, together with *Pt 7, Ch 4, 5.1 Requirements 5.1.2* to *Pt 7, Ch 4, 5.1 Requirements 5.1.3* are to be complied with.

5.1.2 The DP system is to be arranged such that failure of any component or system necessary for the continuing correct functioning of the DP system, or the loss of any one compartment as a result of fire or flooding, will not result in a loss of position. This is to be verified by means of a FMEA. See *Pt 7, Ch 4, 1.3 Information and plans required to be submitted 1.3.6*.

5.1.3 Thruster units are to be installed in separate machinery compartments, separated by a watertight A-60 class division.

5.1.4 Generating sets, switchboards and associated equipment are to be located in at least two compartments separated by an A-60 class division, so that at least half of the equipment will be available following a fire or similar fault in one of the

compartments. If the equipment is located below the operational waterline, the division is also to be watertight. There is to be provision to connect the switchboard sections together by means of circuit-breakers.

5.1.5 Duplicated cables and pipes for services essential for the correct functioning of the DP system are not to be routed through the same compartments. If this is not practicable, then they are to be carried in A-60 protected ducts. The termination arrangements are also to take due account of the degree of protection. Alternative arrangements will be considered.

5.1.6 Where duplicated cables and pipes for services essential for the correct functioning of the DP system are installed in adjacent compartments, A-60 rated fire protection is to be provided between the spaces. Details of alternative arrangements which demonstrate essential equipment located in an adjacent space will continue to operate satisfactorily and essential services will continue to be available in the event of a fire in the adjacent space may be submitted for consideration.

5.1.7 An additional/emergency automatic control unit is to be provided at an emergency control station, in a compartment separate from that for the main control station, and is to be arranged to operate independently from the working and standby control units required by *Pt 7, Ch 4, 4.1 Requirements 4.1.8*.

5.1.8 Arrangements are to be provided such that, in the event of a failure of the working and standby control units, a smooth transfer of control to the emergency control unit may be effected from the emergency control station by manual means.

5.1.9 Arrangements are to be provided at the emergency control station so that changes in the resultant vectorial thrust output may be readily effected by a single operator action.

5.1.10 The control/indication unit of one of the position reference systems required by *Pt 7, Ch 4, 4.1 Requirements 4.1.9* is to be located at the emergency control station. A repeater control/indication unit from this system is to be located at the main control station.

5.1.11 One of the heading reference sensors required by *Pt 7, Ch 4, 4.1 Requirements 4.1.10* is to be located at the emergency control station.

5.1.12 One wind sensor is to directly supply the additional/emergency control unit.

5.1.13 The additional/emergency control unit is to be supplied from its own independent UPS, see *Pt 7, Ch 4, 2.3 Electrical systems 2.3.10*.

■ *Section 6* **Performance Capability Rating (PCR)**

6.1 Requirements

6.1.1 Where the **DP** notation is to be supplemented with a Performance Capability Rating (PCR) (see *Pt 7, Ch 4, 1.2 Classification notations 1.2.2*), the calculation will be carried out using the information specified in *Pt 7, Ch 4, 1.3 Information and plans required to be submitted 1.3.7*.

6.1.2 Two rating numerals are calculated:

- (a) The first numeral represents the percentage of time that the ship can remain on station when subjected to a set of standard environmental conditions (North Sea fully developed) with all thrusters operating.
- (b) The second numeral represents the percentage of time that the ship can remain on station when subjected to a set of standard environmental conditions (North Sea fully developed) with the most effective thruster being inoperative.

A typical rating might be (95), (70).

6.1.3 In calculating the PCR, the following parameters are considered:

- (a) Thruster force vectors.
- (b) Thruster/thruster, thruster/hull and thruster/current interactions.
- (c) Sea current loads on the ship.
- (d) Wind force on the ship.
- (e) Wave drift force on the ship.

6.1.4 Where the ship has been subject to alteration or addition, which may affect the performance characteristics of the DP system, the PCR is to be recalculated.

■ **Section 7**
Testing

7.1 General

7.1.1 Control units are to be surveyed at the manufacturer's works and are to be tested in accordance with the approved test schedule to the Surveyor's satisfaction, *see Pt 7, Ch 4, 1.3 Information and plans required to be submitted 1.3.5.*

7.1.2 Before a new installation (or any existing installation, which has been subject to alteration or addition which may affect the performance characteristics of the system) is put into service, sea trials are to be carried out to the approved schedule and to the Surveyor's satisfaction, *see Pt 7, Ch 4, 1.3 Information and plans required to be submitted 1.3.5.*

7.1.3 The suitability of the dynamic positioning system is to be demonstrated during sea trials, observing the following:

- (a) Response of the system to simulated failures of major items of control and mechanical equipment, including loss of electrical power, verifying the findings of the FMEA where required.
- (b) Response of the system under a set of predetermined manoeuvres for changing:
 - (i) Location of area of operation.
 - (ii) Heading of the ship.
- (c) Continuous operation of the system over a period of four to six hours.

7.1.4 Two copies of the dynamic positioning sea trial test schedules, as required by *Pt 7, Ch 4, 1.3 Information and plans required to be submitted 1.3.5*, each signed by the Surveyor and Builder, are to be provided on completion of the survey. One copy is to be placed and retained on board the ship and the other submitted to LR.

7.1.5 Records and data regarding the performance capability of the dynamic positioning system are to be maintained on board the ship and are to be made available at the time of the Annual Survey, *see Pt 1, Ch 3, 2.2 Annual Surveys 2.2.23.*

Section

- 1 **General**
- 2 **Oil recovery**
- 3 **Ship structure**
- 4 **Machinery arrangements**
- 5 **Electrical equipment**
- 6 **Fire protection and extinction**
- 7 **Operating Manual**

■ Section 1 General

1.1 Application

1.1.1 The requirements of this Chapter apply to ships equipped to handle, store and transport oil recovered from a spill in emergency situations.

1.1.2 For ships of less than 500 gross tons, also fishing vessels of 12 m length and over, but less than 45 m length, and ships not fitted with propelling machinery, the arrangements for fire protection and extinction are to comply with *Pt 7, Ch 5, 6 Fire protection and extinction*. Consideration will be given to the acceptance of the fire safety measures for oil recovery ships prescribed and approved by the Government of the Flag State.

1.1.3 For ships of 500 gross tons and over, also fishing vessels of 45 m length and over, it is the responsibility of the Government of the Flag State to give effect to the fire safety measures, see *Pt 6, Ch 4, 1.1 Application*. Where the Government of the Flag State has no National Requirements for oil recovery ships, LR will apply the fire safety measures required by *Pt 7, Ch 5, 6 Fire protection and extinction* for classification purposes.

1.1.4 Requirements additional to these Rules may be imposed by the National Authority with whom the ship is registered and/or by the Administration within whose territorial jurisdiction the ship is intended to operate.

1.2 Classification and class notations

1.2.1 A ship complying with the requirements of this Chapter will be eligible for the notation **Oil Recovery**.

1.2.2 A ship dedicated solely to oil recovery duties will be given the class notation **Oil Recovery Ship**. The scantlings will be specially considered on the basis of the requirements of *Pt 4, Ch 9 Double Hull Oil Tankers*.

1.3 Surveys

1.3.1 The arrangements and equipment referred to in this Chapter are to be examined and tested on completion of the installation and, subsequently, annually.

1.4 Plans and supporting documentation

1.4.1 In addition to the supporting documentation required for classification as specified in other Parts of the Rules, details relevant to oil recovery operations are to be submitted.

1.4.2 Plans covering the following items are to be submitted for approval:

- Structural support in way of equipment.
- Structural arrangement of recovered oil tanks including access.
- Piping system arrangements for recovered oil including venting.
- Power supply, electrical protection and cabling for oil recovery equipment.
- Hazardous areas and spaces.

- Electrical equipment located in hazardous areas and spaces.
- Structural fire protection and extinguishing equipment.

1.4.3 The following supporting documents are to be submitted:

- General arrangement of recovery equipment, including portable items, handling facilities, access, ventilation details, arrangement of other openings to hazardous spaces and adjacent compartments, machinery exhaust outlet positions.
- Gas detection equipment specification.
- Operating Manual.

1.4.4 The following supporting calculations are to be submitted:

- Deck equipment support structure loadings.
- Schedule of loads on the electrical system for oil recovery operations.

■ *Section 2* **Oil recovery**

2.1 General

2.1.1 The ship is to be capable of performing the following functions at a safe distance from the source of oil spill:

- Removal of the oil from the surface of the sea.
- Handling, storage and transportation of the recovered oil.

2.2 Equipment and deck arrangement

2.2.1 The arrangements for collection, handling and transfer of recovered oil are to be such that the probability of oil spill on deck and overflow is minimised and the operation is to be performed as far away from the accommodation spaces as practicable.

2.2.2 In way of working areas, hand rails and gratings or other non-slip surfaces are to be provided.

2.2.3 Means are to be provided to keep deck spills away from the accommodation and service areas. This may be accomplished by provision of a permanent continuous coaming not less than 150 mm high.

2.2.4 At least two portable instruments are to be available on board for gas detection.

2.2.5 For engines used in oil recovery operations, see *Pt 7, Ch 5, 4.4 Exhaust systems*.

2.2.6 Masts and derricks, etc. are to comply with the appropriate Sections of Chapters *Ch 2 Derrick Systems* and *Ch 3 Launch and Recovery Appliances for Survival Craft and Rescue Boats* of LR's *Code for Lifting Appliances in a Marine Environment, November 2015*.

■ *Section 3* **Ship structure**

3.1 Structural arrangement

3.1.1 The position of bulkheads is to comply with the requirements of *Pt 3, Ch 3, 4 Bulkhead requirements*.

3.1.2 Any tanks not utilised during oil recovery operations are to be arranged so that recovered oil cannot be transferred to them inadvertently.

3.1.3 In tanks intended for recovered oil, internal obstructions are to be avoided as far as practicable to prevent the entrapment of foreign objects usually present in recovered oil. Adequate drainage openings are to be provided to ensure free flow of residues to assist in cleaning and gas freeing on completion of recovery operations.

3.1.4 Tanks used for the storage of recovered oil are to be located outside the accommodation and machinery spaces.

3.1.5 Except where permitted by *Pt 7, Ch 5, 3.1 Structural arrangement 3.1.6* and *Pt 7, Ch 5, 3.1 Structural arrangement 3.1.7*, tanks intended for the storage of recovered oil are to be separated from accommodation and machinery spaces by cofferdams. Cofferdams are to be at least one frame spacing in length (600 mm minimum) and are to cover the whole area of the boundary under consideration.

3.1.6 A pump room, fuel oil bunker, water ballast tank or other closed space where oil recovery handling equipment is stored will be accepted in lieu of a cofferdam.

3.1.7 In the case of a ship not primarily intended for oil recovery operations, where cofferdams are impractical to arrange, tanks arranged adjacent to machinery spaces may be accepted for storage of recovered oil. Acceptance will be conditional upon the tank boundary bulkheads being readily accessible for inspection. The bulkheads are to be carried continuously through joining structure to the top of the tank, where full penetration welding is to be carried out. Such tanks will require to be pressure tested at every Periodical Survey, see *Table 1.9.1 Testing requirements* in *Pt 3, Ch 1*, as applicable to oil tankers. Special consideration will be given to arrangements incorporating double bottom tanks in these locations.

3.1.8 All openings to tanks for recovered oil are to be located on the open deck. This includes sounding pipes, vent pipes, and hatches for the deployment of portable pumps and hoses. Suitable access hatches, not less than 600 mm x 600 mm, are to be arranged to facilitate tank cleaning and gas freeing. Dual access hatches, as widely separated as practicable, are to be provided for tanks of a cellular internal structure.

3.1.9 Where there is a risk of significant sloshing induced loads, additional strength calculations may be required, see *Pt 3, Ch 3, 5.4 Design pressure for partially filled tanks*.

3.1.10 Where recovered oil temperatures are to be increased significantly above 65°C during transit voyages, attention is drawn to *Pt 4, Ch 9, 12 Cargo temperatures* regarding thermal stress considerations.

3.2 Scantlings

3.2.1 The scantlings and arrangements are, in general, to be as required by *Pt 4, Ch 1 General Cargo Ships*. If the ship is to perform the duties of a supply ship the requirements of *Pt 4, Ch 4 Offshore Support Vessels* are also to be complied with, as applicable.

■ *Section 4* **Machinery arrangements**

4.1 Piping arrangements

4.1.1 Piping arrangements for the recovered oil system are to be located outside machinery spaces and are to have no connections to such spaces.

4.1.2 When the ship is in oil recovery mode, means are to be provided to isolate the oil recovery system from any other system to which it may be connected.

4.1.3 Ventilation outlets from the recovered oil tanks are to have a minimum height of 2,4 m above deck and be fitted with flame screens. Temporary pipe sections may be used for this purpose. Outlets are to be located not less than 5 m measured horizontally from the nearest air intakes and openings to accommodation and enclosed spaces containing a source of ignition and from deck machinery and equipment which may constitute an ignition hazard.

4.1.4 Each recovered oil tank is to be fitted with suitable means of ascertaining the liquid level in the tank. Sounding pipes or other approved devices are acceptable for this purpose.

4.2 Pump room for recovered oil

4.2.1 Pump rooms are to be fitted with a permanent ventilation system of the mechanical extraction type.

4.2.2 The ventilation system is to be capable of being operated from outside the compartment being ventilated and a notice is to be fixed near the entrance stating that no person is to enter the space until the ventilation system has been in operation for a specified period, sufficient to achieve at least five air changes based on the gross volume of the space.

4.2.3 The ventilation system is to be capable of at least six air changes per hour, based on the gross volume of the space.

4.2.4 Protection screens of not more than 13 mm square mesh are to be fitted outside openings of ventilation ducts, and ventilation intakes are to be so arranged as to minimise the possibility of recycling hazardous vapours from any ventilation discharge opening. Vent exhausts are to be arranged to discharge to a safe place on the open deck and comply with the requirements of *Pt 7, Ch 5, 4.2 Pump room for recovered oil 4.2.5*.

Note If the pump room is designed to recover chemicals listed in *Chapter 17 Summary of minimum requirements of the IBC Code - International Code for the Construction and Equipment of Ships Carrying Dangerous Chemicals in Bulk Amended by Resolution MEPC.225(64)* the vent exhausts are to be arranged to discharge upwards.

4.2.5 The vent exhausts from pump rooms are to discharge at least 3 m above deck, and from the nearest air intakes or openings to accommodation and enclosed working spaces, and from possible sources of ignition.

4.2.6 Ventilation fans to be constructed in accordance with *Pt 5, Ch 15, 1.8 Cargo pump-room ventilation*.

4.2.7 Pump rooms are to have no direct communication with machinery spaces.

4.2.8 Bilge drainage of the pump room is to be effected by pumps or bilge ejector suction. For ships of less than 500 gross tons, the pump room bilge may be drained by a hand pump having a 50 mm bore suction.

4.3 Ventilation of machinery spaces

4.3.1 Where machinery spaces adjacent to recovered oil tanks are permitted by *Pt 7, Ch 5, 3.1 Structural arrangement 3.1.7*, the ventilation arrangements are to comply with *Pt 7, Ch 5, 5.4 Ventilation 5.4.1* and *Pt 7, Ch 5, 5.4 Ventilation 5.4.1*.

4.4 Exhaust systems

4.4.1 The exhaust lines of diesel engines, boilers and equipment containing sources of ignition and the vents of diesel engine crank cases are to be led to a position outside any hazardous area as defined in *Pt 7, Ch 5, 5.3 Hazardous zones and spaces*. In addition, suitable spark arrestors are to be fitted.

4.5 Miscellaneous

4.5.1 Low sea suction is to be provided to supply water for the machinery and all fire pumps.

4.5.2 Means are to be provided to enable heating coils in recovered oil tanks and adjacent tanks to be blanked off during recovery operations.

4.5.3 The heating medium supply and return lines are not to penetrate the recovered oil tank plating, other than at the top of the tank, to reduce the possibility of the recovered oil entering the heating system in the event of a failure of the heating pipework within the tank.

4.5.4 If required to facilitate discharge operations, steam returns are to be led to an observation tank which is to be in a well-ventilated and well-lighted part of the machinery space remote from the boilers.

■ Section 5 Electrical equipment

5.1 General

5.1.1 The electrical installation is to comply with the relevant requirements of *Pt 6, Ch 2 Electrical Engineering*, with the specific exceptions of *Pt 6, Ch 2, 14.1 General*, *Pt 6, Ch 2, 14.2 Selection of equipment for use in explosive gas atmospheres*, *Pt 6, Ch 2, 14.5 Hazardous zones and spaces*, *Pt 6, Ch 2, 14.7 Ventilation*, *Pt 6, Ch 2, 14.8 Pressurisation* and *Pt 6, Ch 2, 14.10 Requirements for tankers intended for the carriage in bulk of oil cargoes having a flash point not exceeding 60°C (closed-cup test)*, which are replaced by *Pt 7, Ch 5, 5.3 Hazardous zones and spaces* to *Pt 7, Ch 5, 5.6 Selection of electrical equipment for installation in hazardous areas* of this Chapter.

5.2 Systems of supply and distribution

5.2.1 Only the systems of generation and distribution, listed under *Pt 6, Ch 2, 5.1 Systems of supply and distribution 5.1.2*, are acceptable.

5.3 Hazardous zones and spaces

5.3.1 The following zones or spaces are regarded as hazardous during and on completion of oil recovery operations, until proven gas-safe:

- (a) The interiors of tanks intended for the storage of recovered oil.
- (b) The interiors of piping systems intended for the handling of recovered oil.
- (c) Spaces separated by a single bulkhead, deck or other tank boundary, from the interior of a tank intended for recovered oil, or having a bulkhead immediately above or below and in line with a bulkhead of a tank intended for recovered oil, unless protected by a diagonal plate in accordance with *Pt 4, Ch 9, 1.2 Application and ship arrangement 1.2.7* or the arrangements comply with the requirements of *Pt 7, Ch 5, 3.1 Structural arrangement 3.1.7*.
- (d) Spaces housing piping systems or other equipment containing or contaminated with recovered oil and having flanged joints or glands or other openings from which leakage of fluid may occur under normal operating conditions.
- (e) Zones on open deck within a 3 m radius of the ventilation outlets, or inspection hatches permitted to be opened under normal operating conditions, of tanks intended for recovered oil.
- (f) Zones on open deck within a 1,5 m radius of any sampling or sounding point of a tank intended for recovered oil.
- (g) Zones on open deck within a 1,5 m radius of any flanged joints, glands or other parts of any equipment containing or contaminated with recovered oil from which leakage may occur under normal operating conditions.
- (h) Zones on open deck within the confines of, and extending 1,5 m beyond, any bund or barrier intended to contain a spillage of recovered oil, up to a height of 1,5 m.
- (i) Zones on open deck within a 1,5 m radius of any opening into a space described by *Pt 7, Ch 5, 5.3 Hazardous zones and spaces 5.3.1* or *Pt 7, Ch 5, 5.3 Hazardous zones and spaces 5.3.1*.
- (j) Zones on open deck over all tanks intended for recovered oil, where the tops of the tanks are exposed to the weather, to the full width of the ship plus 3 m fore and aft of the forwardmost and aftmost tank bulkhead, up to a height of 0,45 m above the deck or to the height of any bulwarks.
- (k) Zones on open deck extending 1,5 m beyond those defined by *Pt 7, Ch 5, 5.3 Hazardous zones and spaces 5.3.1* to *Pt 7, Ch 5, 5.3 Hazardous zones and spaces 5.3.1*.
- (l) Any enclosed or semi-enclosed space having a direct opening into a hazardous zone or space identified above, unless the space is protected by pressurisation in accordance with *Pt 7, Ch 5, 5.5 Pressurisation 5.5.1* or *Pt 7, Ch 5, 5.5 Pressurisation 5.5.2*, or the opening is a ventilation outlet arranged in compliance with *Pt 7, Ch 5, 5.4 Ventilation 5.4.2*.

5.4 Ventilation

5.4.1 The extent of any hazardous zone within an enclosed or semi-enclosed space may be limited to that defined for an equivalent situation on open deck, provided that the ventilation arrangements fulfill all the following conditions:

- (a) Mechanical ventilation is provided, with the air intake and outlet located outside any hazardous area defined by *Pt 7, Ch 5, 5.3 Hazardous zones and spaces 5.3.1*, ensuring at least 12 air changes per hour, and leaving no region of stagnant air.
- (b) Ventilation air flow is continuously monitored and so arranged that, in the event of failure of ventilation, an alarm is given at an attended station.

5.4.2 An enclosed or semi-enclosed space having a ventilation outlet situated in a hazardous zone, as defined under *Pt 7, Ch 5, 5.3 Hazardous zones and spaces 5.3.1* or *Pt 7, Ch 5, 5.3 Hazardous zones and spaces 5.3.1*, may be regarded as non-hazardous if fulfilling all the following conditions:

- (a) The space has mechanical ventilation with the air intake located outside any hazardous area defined by *Pt 7, Ch 5, 5.3 Hazardous zones and spaces 5.3.1*.
- (b) The ventilation outlet is equipped with a self-closing flap or other suitable means of closure operating automatically on loss of ventilation airflow.
- (c) The space contains no equipment of a type described in *Pt 7, Ch 5, 5.3 Hazardous zones and spaces 5.3.1*, or vent from or opening into any hazardous space or zone defined by *Pt 7, Ch 5, 5.3 Hazardous zones and spaces 5.3.1*, other than the ventilation outlet under consideration.
- (d) The space is separated by at least two gastight bulkheads from the interior of any tank intended for recovered oil.

5.5 Pressurisation

5.5.1 A space having access to a hazardous space or zone as defined under *Pt 7, Ch 5, 5.3 Hazardous zones and spaces 5.3.1* to *Pt 7, Ch 5, 5.3 Hazardous zones and spaces 5.3.1* may be regarded as non-hazardous if it fulfills all of the following conditions:

- (a) Access is by means of an air-lock, having gastight doors, the inner of which, as a minimum, is self-closing without any hold-back arrangement.
- (b) It is maintained at an overpressure of at least 50 Pa relative to the external hazardous area by ventilation from a non-hazardous area.
- (c) The relative air pressure within the space is continuously monitored and so arranged that, in the event of loss of overpressure, an alarm is given at an attended station.
- (d) It contains no piping system or equipment of a type described in *Pt 7, Ch 5, 5.3 Hazardous zones and spaces 5.3.1*, and no vent from or opening into any hazardous space or zone defined by *Pt 7, Ch 5, 5.3 Hazardous zones and spaces 5.3.1*, other than the access under consideration
- (e) It is separated by at least two gastight bulkheads from the interior of any tank intended for recovered oil.

5.5.2 A space having access to a hazardous zone, as defined under *Pt 7, Ch 5, 5.3 Hazardous zones and spaces 5.3.1* or *Pt 7, Ch 5, 5.3 Hazardous zones and spaces 5.3.1*, may be regarded as non-hazardous if it fulfills all of the following conditions:

- (a) Access is by means of a gastight self-closing door without any hold back arrangement.
- (b) It is maintained at an overpressure in accordance with *Pt 7, Ch 5, 5.5 Pressurisation 5.5.1*.
- (c) The air pressure within the space is monitored in accordance with *Pt 7, Ch 5, 5.5 Pressurisation 5.5.1*.
- (d) It contains no piping system or equipment of a type described in *Pt 7, Ch 5, 5.3 Hazardous zones and spaces 5.3.1*, and no vent from or opening into any hazardous space or zone defined by *Pt 7, Ch 5, 5.3 Hazardous zones and spaces 5.3.1*, other than the access under consideration.
- (e) It is separated from the interior of any tank intended for recovered oil in accordance with *Pt 7, Ch 5, 5.5 Pressurisation 5.5.1*.

5.5.3 A space having access to a hazardous space or zone, as defined under *Pt 7, Ch 5, 5.3 Hazardous zones and spaces 5.3.1* to *Pt 7, Ch 5, 5.3 Hazardous zones and spaces 5.3.1*, and fulfilling the conditions given under *Pt 7, Ch 5, 5.5 Pressurisation 5.5.2* to *Pt 7, Ch 5, 5.5 Pressurisation 5.5.2* may be regarded, for the purposes of selection of electrical equipment, as equivalent to an open-deck hazardous area such as defined under *Pt 7, Ch 5, 5.3 Hazardous zones and spaces 5.3.1*.

5.6 Selection of electrical equipment for installation in hazardous areas

5.6.1 The installation of electrical equipment in hazardous areas is to be minimised as far as is consistent with operational necessity and the provision of lighting, monitoring, alarm or control facilities enhancing the overall safety of the ship.

5.6.2 When electrical equipment is to be installed in hazardous areas, unless permitted otherwise by *Pt 7, Ch 5, 5.6 Selection of electrical equipment for installation in hazardous areas 5.6.3* or *Pt 7, Ch 5, 5.6 Selection of electrical equipment for installation in hazardous areas 5.6.4*, it is to be of a 'safe type', as listed below, certified or approved by a competent authority for Group IIA, temperature class T3. The construction and type testing is to be in accordance with IEC Publication 60079: *Electrical Equipment for Explosive Gas Atmospheres*, or an acceptable and relevant National Standard.

- Intrinsically safe Ex `i'
- Increased safety Ex `e'
- Flameproof Ex `d'
- Pressurised enclosure Ex `p'
- Powder filled Ex `q'
- Encapsulated Ex `m'

5.6.3 Consideration may additionally be given to the use of equipment of the following types:

- (a) Equipment such as control panels, protected by purging and pressurisation and capable of being verified by inspection as meeting the requirements of IEC 60079-2.
- (b) Simple non-energy-storing apparatus having negligible surface temperature rise in normal operation, such as limit switches, strain gauges, etc. incorporated in intrinsically-safe circuits.
- (c) Submersible pumps, having at least two independent methods of shutting down automatically in the event of low liquid level.
- (d) Radio aerials having robust construction, meeting the relevant requirements of IEC 60079-15. Additionally, in the case of transmitter aerials, it is to be shown, by detailed study or measurement, or by limiting the peak radiated power and field

strength to 1 W and 30 V/m, respectively, that they present negligible risk of inducing incendive sparking in adjacent structures or equipment.

- (e) Electrical apparatus having a special type of protection (Ex's'), certified or approved by a competent authority.
- (f) Electrical apparatus having the type of protection Ex'n' (or Ex'N'), that, in normal operation, is not capable of igniting a surrounding explosive gas atmosphere, and in which a fault capable of causing ignition is not likely to occur.

5.6.4 Equipment not meeting the requirements of *Pt 7, Ch 5, 5.6 Selection of electrical equipment for installation in hazardous areas 5.6.5 to Pt 7, Ch 5, 5.6 Selection of electrical equipment for installation in hazardous areas 5.6.14* may be installed in hazardous zones or spaces, or locations rendered non-hazardous by ventilation or pressurisation, if not required to be energised during oil recovery operations, and not essential for the safety of the ship or crew. Such equipment is to be controlled by multi-pole switches or circuit breakers situated outside any hazardous area. Provision is to be made for the complete isolation of these circuits and locking the means of control in the off position.

5.6.5 In tanks and piping systems defined by *Pt 7, Ch 5, 5.3 Hazardous zones and spaces 5.3.1* and *Pt 7, Ch 5, 5.3 Hazardous zones and spaces 5.3.1*, only the following electrical equipment will be permitted:

- (a) Intrinsically-safe apparatus of category 'ia'.
- (b) Simple apparatus, as defined under *Pt 7, Ch 5, 5.6 Selection of electrical equipment for installation in hazardous areas 5.6.3*, incorporated in an intrinsically-safe circuit of category 'ia'.
- (c) Submersible pumps as defined under *Pt 7, Ch 5, 5.6 Selection of electrical equipment for installation in hazardous areas 5.6.3*.
- (d) Ex's' apparatus, certified for use in Zone 0 as defined by IEC 60079-10.
- (e) Cable required for the operation of the equipment installed.

5.6.6 In spaces adjacent to tanks, as defined by *Pt 7, Ch 5, 5.3 Hazardous zones and spaces 5.3.1*, with no mechanical ventilation, only the following electrical equipment will be permitted:

- (a) That described in *Pt 7, Ch 5, 5.6 Selection of electrical equipment for installation in hazardous areas 5.6.5*, *Pt 7, Ch 5, 5.6 Selection of electrical equipment for installation in hazardous areas 5.6.5*, *Pt 7, Ch 5, 5.6 Selection of electrical equipment for installation in hazardous areas 5.6.5* and *Pt 7, Ch 5, 5.6 Selection of electrical equipment for installation in hazardous areas 5.6.5*.
- (b) Ex'd' lighting fittings.
- (c) Ex'p' lighting fittings of either the air-driven type, or pressurised from an external source of protective gas and arranged to be de-energised automatically on loss of pressurisation.
- (d) Gas detector heads having sinter-type flametrap protection, included within an intrinsically-safe circuit, all of which is to be certified as a system.
- (e) Ex'd' alarm sounders, without internal sparking contacts.
- (f) Cables for impressed current cathodic protection systems (for external hull protection only) installed in heavy gauge steel pipes with gastight joints up to the upper deck; the arrangements are to comply with *Pt 3, Ch 2, 3.5 External hull protection 3.5.3* and *Ch 15 Corrosion Prevention* of the Rules for Materials.
- (g) Through runs of cables, installed in heavy gauge steel pipes with gastight joints.

The electrical equipment described in *Pt 7, Ch 5, 5.6 Selection of electrical equipment for installation in hazardous areas 5.6.6*, *Pt 7, Ch 5, 5.6 Selection of electrical equipment for installation in hazardous areas 5.6.6* and *Pt 7, Ch 5, 5.6 Selection of electrical equipment for installation in hazardous areas 5.6.6* will be permitted only where personnel are required to have access to the space during oil recovery operations.

5.6.7 In spaces adjacent to tanks, as defined by *Pt 7, Ch 5, 5.3 Hazardous zones and spaces 5.3.1* having mechanical ventilation, and in spaces and zones containing piping systems, equipment, etc. or close to vents, flanges, etc. and other zones as defined by *Pt 7, Ch 5, 5.3 Hazardous zones and spaces 5.3.1* to *Pt 7, Ch 5, 5.3 Hazardous zones and spaces 5.3.1*, only the following electrical equipment will be permitted:

- (a) That described in *Pt 7, Ch 5, 5.6 Selection of electrical equipment for installation in hazardous areas 5.6.6*.
- (b) Intrinsically-safe apparatus of category 'ib'.
- (c) Simple apparatus, as defined under *Pt 7, Ch 5, 5.6 Selection of electrical equipment for installation in hazardous areas 5.6.3*, incorporated in an intrinsically-safe circuit of category 'ib'.
- (d) Other apparatus certified as Ex'e', Ex'd', Ex'q', Ex'm' or Ex's'.
- (e) Pressurised equipment, certified Ex'p', or as described in *Pt 7, Ch 5, 5.6 Selection of electrical equipment for installation in hazardous areas 5.6.3*, arranged to be de-energised automatically on loss of pressurisation.

(f) Through runs of cable in spaces and zones described in *Pt 7, Ch 5, 5.3 Hazardous zones and spaces 5.3.1* to *Pt 7, Ch 5, 5.3 Hazardous zones and spaces 5.3.1* only.

5.6.8 In zones defined by *Pt 7, Ch 5, 5.3 Hazardous zones and spaces 5.3.1* and *Pt 7, Ch 5, 5.3 Hazardous zones and spaces 5.3.1*, only the following electrical equipment will be permitted:

- (a) That described in *Pt 7, Ch 5, 5.6 Selection of electrical equipment for installation in hazardous areas 5.6.7*.
- (b) Pressurised equipment, certified Ex'p', or as described in *Pt 7, Ch 5, 5.6 Selection of electrical equipment for installation in hazardous areas 5.6.3*, arranged to give an audible and visual alarm at a manned station in the event of loss of pressurisation.
- (c) Equipment as described in *Pt 7, Ch 5, 5.6 Selection of electrical equipment for installation in hazardous areas 5.6.3* and *Pt 7, Ch 5, 5.6 Selection of electrical equipment for installation in hazardous areas 5.6.3*.

5.6.9 Electrical installations in enclosed or semi-enclosed spaces as described in *Pt 7, Ch 5, 5.3 Hazardous zones and spaces 5.3.1*, are to comply with the requirements for the space or zone into which the opening leads, unless ventilated in accordance with *Pt 7, Ch 5, 5.4 Ventilation 5.4.1* or *Pt 7, Ch 5, 5.4 Ventilation 5.4.2*.

5.6.10 Electrical installations in enclosed or semi-enclosed spaces, ventilated as described in *Pt 7, Ch 5, 5.4 Ventilation 5.4.1*, are to comply with the requirements for hazardous zones as described in *Pt 7, Ch 5, 5.3 Hazardous zones and spaces 5.3.1* to *Pt 7, Ch 5, 5.3 Hazardous zones and spaces 5.3.1* within the radii or distances from adjacent sources of hazard or sources within the space specified by these paragraphs. Equipment within a radius of 3 m from any ventilation outlet of such a space is to be of a type described in *Pt 7, Ch 5, 5.6 Selection of electrical equipment for installation in hazardous areas 5.6.8*. Equipment not of a type described in *Pt 7, Ch 5, 5.6 Selection of electrical equipment for installation in hazardous areas 5.6.7* is to be provided with a means of disconnection capable of being controlled from an attended station in the event of ventilation failure. Where the means of disconnection is located within the space, then it is to be of a 'safe type'.

5.6.11 Electrical installations in machinery spaces adjacent to recovered oil tanks where permitted by *Pt 7, Ch 5, 3.1 Structural arrangement 3.1.7*, are to comply with the requirements of *Pt 7, Ch 5, 5.6 Selection of electrical equipment for installation in hazardous areas 5.6.10*, and the additional requirement that equipment within 0,45 m of the tank bulkhead or the bottom of the space is to be of a type described in *Pt 7, Ch 5, 5.6 Selection of electrical equipment for installation in hazardous areas 5.6.8*.

5.6.12 In pressurised spaces defined by *Pt 7, Ch 5, 5.5 Pressurisation 5.5.1*, electrical equipment not of a type described in *Pt 7, Ch 5, 5.6 Selection of electrical equipment for installation in hazardous areas 5.6.8* is to be automatically disconnected in the event of loss of overpressure. Other equipment is to be provided with a means of disconnection capable of being controlled from an attended station in the event of loss of overpressure. Where the means of disconnection is located within the space, it is to be of a 'safe type'. Emergency lighting, pressure monitoring equipment and any alarm sounders or lights are to be of types described in *Pt 7, Ch 5, 5.6 Selection of electrical equipment for installation in hazardous areas 5.6.6*.

5.6.13 In pressurised spaces defined by *Pt 7, Ch 5, 5.5 Pressurisation 5.5.2*, any equipment not of a type described in *Pt 7, Ch 5, 5.6 Selection of electrical equipment for installation in hazardous areas 5.6.8* is to be provided with a means of disconnection capable of being controlled from an attended station in the event of loss of overpressure.

5.6.14 In pressurised spaces defined by *Pt 7, Ch 5, 5.5 Pressurisation 5.5.3*, only electrical equipment as described in *Pt 7, Ch 5, 5.6 Selection of electrical equipment for installation in hazardous areas 5.6.8* may be permitted. Any equipment that is not of a type described in *Pt 7, Ch 5, 5.6 Selection of electrical equipment for installation in hazardous areas 5.6.7* is to be provided with a means of disconnection capable of being controlled from an attended station in the event of loss of overpressure. Emergency lighting, pressure monitoring equipment and any alarm sounders or lights are to be of types described in *Pt 7, Ch 5, 5.6 Selection of electrical equipment for installation in hazardous areas 5.6.6*.

■ Section 6 Fire protection and extinction

6.1 Structural fire protection

6.1.1 Exterior boundaries of superstructures and deckhouses enclosing accommodation and service spaces, including any overhanging decks which support such accommodation and service spaces, are to be insulated to 'A-60' standard for all parts which face deck areas where there are arrangements for collection, handling and transfer of recovered oil and for a distance 3 m aft or forward thereof.

6.1.2 Windows and side scuttles in the exterior boundaries, referred to in *Pt 7, Ch 5, 6.1 Structural fire protection 6.1.1*, are to be provided with permanently installed inside covers of steel. Aluminium alloy components are not to be used in the construction of the windows and side scuttles.

6.1.3 As an alternative to compliance with *Pt 7, Ch 5, 6.1 Structural fire protection 6.1.1* and *Pt 7, Ch 5, 6.1 Structural fire protection 6.1.2*, a fixed water spraying system may be accepted. The system is to be capable of delivering water at a rate of 10 litres/m²/min. on all boundaries, windows and side scuttles, that would otherwise be required to comply with *Pt 7, Ch 5, 6.1 Structural fire protection 6.1.1* and *Pt 7, Ch 5, 6.1 Structural fire protection 6.1.2*.

6.2 Fire-extinguishing arrangements

6.2.1 Deck areas, where there are arrangements for the collection, handling and transfer of recovered oil, are to be provided with the following fire-extinguishing equipment:

- (a) Two dry powder fire-extinguishers, each at least 50 kg capacity.
- (b) At least one portable low expansion foam applicator.

6.2.2 The fire-extinguishers are to be located near the working deck identified in *Pt 7, Ch 5, 6.2 Fire-extinguishing arrangements 6.2.1* and are to be fitted with discharge hoses.

6.2.3 The foam installation is to be capable of applying foam to any part of the working deck. The capacity of any applicator is to be not less than 400 litres/min. of foam solution and the applicator throw in still air conditions is to be not less than 15 m. Sufficient foam concentrate is to be provided for at least 0,4 litres/m² of the working deck area with a minimum quantity of 200 litres.

6.3 Fireman's outfits

6.3.1 At least two firemen's outfits, additional to those required by *Pt 6, Ch 4, 2 Fire detection, protection and extinction* or SOLAS Reg II-2/C, *10 Fire-fighter's outfits* as applicable, are to be provided.

■ Section 7 Operating Manual

7.1 General

7.1.1 Information regarding the safe use of the ship with respect to the oil recovery and subsequent operations is to be prepared.

7.1.2 The Operating Manual is, in general, to contain information regarding procedures for:

- (a) establishing and maintaining a safe atmosphere in any space(s) liable to become hazardous during oil recovery and subsequent operations;
- (b) isolation, where necessary, of electrical equipment in zones or spaces considered hazardous during oil recovery and subsequent operations, and in spaces described in *Pt 7, Ch 5, 7.1 General 7.1.2* prior to carrying out, or on failure of, the measures required to establish and maintain a safe atmosphere;
- (c) fire-fighting;
- (d) gas measurements;
- (e) recovery and storage of oil;
- (f) ballasting;
- (g) transfer of recovered oil;
- (h) tank cleaning;
- (i) gas freeing; and
- (j) contacts in the event of an emergency.

Section

- 1 **General**
- 2 **Arrangements**
- 3 **Positioning, monitoring and control arrangements**
- 4 **Fire protection, detection and extinction**
- 5 **Piping systems**
- 6 **Trials and testing**

■ *Section 1*
General

1.1 Application

1.1.1 The requirements of this Chapter apply to tankers equipped with bow/stern loading arrangements to facilitate the transfer of cargo oil from offshore loading terminals, such as loading platforms, loading buoys, FPSOs and FSUs, and are additional to those applicable in other Parts of the Rules. These requirements also apply to submerged turret loading systems where applicable.

1.1.2 Requirements additional to these Rules may be imposed by the National Authority with whom the ship is registered and/or by the Administration within whose territorial jurisdiction the ship is intended to operate.

1.1.3 The materials used are to be suitable for the intended service conditions.

1.2 Class notations

1.2.1 Ships complying with the requirements of this Chapter will be eligible to have one of the following special features notations included in the class notation:

- (a) Ships fitted with a bow loading system, **BLS**.
- (b) Ships fitted with a stern loading system, **SLS**.
- (c) Ships fitted with submerged turret loading systems, **TLS**.

1.3 Surveys

1.3.1 The survey of these items is to be arranged to coincide with hull and machinery surveys, *see Pt 1, Ch 3 Periodical Survey Regulations*.

1.4 Submission of plans and documentation

1.4.1 In addition to the plans and information required by other relevant Sections of the Rules, the plans and information detailed below are to be submitted:

(a) Bow/stern loading:

Detail drawing(s) showing:

- Cargo loading equipment.
- Manifold position and pipeline connections.
- Mooring equipment layout, including design loads and supporting structure.
- Fire safety arrangements.
- Control station(s).

(b) Systems and arrangements:

General arrangement. Plans showing the general arrangement of all areas where the piping systems are located, together with ventilation arrangements and details of openings for any enclosed spaces at the fore and/or aft part of the ship.

Diagrammatic arrangement. Plans indicating all piping systems arrangements associated with loading systems between cargo tank area and manifold. The plans are to include details of means of isolation, manifold arrangement, means of draining, inerting, cleaning and gas freeing of the cargo piping. Also details of manifold drip tray arrangements with means of drainage, together with any stripping line arrangements, are to be submitted. If the ship is to be installed with a vapour emission control system, plans showing details of piping arrangements are also to be submitted.

Piping system specification. Piping design information which includes the materials specifications, design pressure, maximum allowable transfer rate, corrosion allowance, and design ambient weather conditions. Also the design forces and moments for which the presentation manifold, together with the terminal flange and associated supporting arrangements have been designed, are to be submitted.

Operating Manuals. Operating Manuals are to be submitted for approval and provided on board. The Manuals are to include the following information:

- Particulars of piping arrangements and control systems.
- Operating criteria.
- Procedures for connecting/disconnecting the cargo hose, isolation arrangements, inerting, cleaning, gas freeing of the pipe line and drainage of the drip tray.
- Procedures to be followed during cargo handling operations. These are to include guidance on procedures to be followed in the event of sudden closure of the terminal valve.
- Detailed communication sequence concerning pre-mooring, mooring, pre-loading, loading and tanker departure phases.

Where the ship is fitted with dynamic positioning and/or a positional mooring system(s), the information required by *Pt 7, Ch 4, 1.3 Information and plans required to be submitted 1.3.7* and *Pt 7, Ch 8, 1.5 Plans and data submission 1.5.6* is also to be submitted as applicable.

(c) **Submerged turret loading:**

Detail drawing(s) showing:

- Arrangement of turret room, including receiving structure, locking mechanism and traction winch equipment with associated supporting structure and design loadings.
- Turret hatch and operating equipment, including hydraulic power pack and control systems, and cargo loading equipment.
- Turret room fire safety arrangements.
- Turret room electrical installations.
- Piping arrangements for all systems associated with the turret loading.

■ Section 2 Arrangements

2.1 Mooring arrangements

2.1.1 The ship is to be provided with sufficient mooring arrangements, which may be combined with the ship's manoeuvring system, to ensure adequate alignment and security during bow, stern or submerged turret loading operations.

2.1.2 The mooring/positioning system is to be arranged to prevent mooring forces being transmitted to the loading line connector.

2.1.3 Suitable single point mooring arrangements are indicated in *Pt 3, Ch 13, 9 Mooring of ships at single point moorings*.

2.1.4 Particular attention is to be given to operational requirements and conditions in the design and mounting of securing devices and fittings. Seatings for equipment are to be designed to avoid the formation of pockets or recesses which may lead to excessive corrosion in service.

2.2 Materials for mooring fittings

2.2.1 Where mooring fittings are used as part of a positional mooring system, they are to comply with the requirements of *Pt 7, Ch 8 Positional Mooring and Thruster-Assisted Positional Mooring Systems*.

2.3 Strength of mooring fittings

2.3.1 The strength of the mooring arrangements associated with the bow/stern loading system is to be considered on the basis of *Pt 3, Ch 13, 9 Mooring of ships at single point moorings*, and *Pt 7, Ch 8 Positional Mooring and Thruster-Assisted Positional Mooring Systems* as applicable.

2.4 Enclosed spaces adjacent to manifold connection

2.4.1 In addition to the arrangements required by *Pt 7, Ch 6, 4 Fire protection, detection and extinction*, the following are to be complied with:

- (a) Spaces where an explosive gas atmosphere may be present are to be suitably ventilated prior to entry.
- (b) Spaces required to be entered during normal operations are to be provided with permanent ventilation arrangements capable of being operated from outside the compartment.

2.4.2 The ventilation arrangements are to provide a minimum of eight air changes per hour, see *Pt 6, Ch 2, 14 Electrical equipment for use in explosive gas atmospheres or in the presence of combustible dusts*.

■ Section 3**Positioning, monitoring and control arrangements****3.1 General**

3.1.1 The requirements of this Section are additional to those given in *Pt 6, Ch 1 Control Engineering Systems*, and *Pt 7, Ch 4 Dynamic Positioning Systems* and *Pt 7, Ch 8 Positional Mooring and Thruster-Assisted Positional Mooring Systems*.

3.1.2 If the ship is fitted with a dynamic positioning system, it is at least to comply with the DP(AM) requirements, see *Pt 7, Ch 4 Dynamic Positioning Systems*.

3.2 Control station

3.2.1 A control station for offshore loading may be arranged within the bow area or on the navigation bridge. All operations concerning positioning of the ship and monitoring of mooring and loading parameters are to be capable of being performed from this station.

3.3 Instrumentation

3.3.1 Bow/stern mooring instrumentation is to monitor:

- (a) Mooring line traction.
- (b) Chain stopper.
- (c) Data logger system for recording of mooring and load parameters.

3.3.2 The mooring system is to be provided with a tension meter capable of continuously indicating the tension during the bow loading operation. Consideration may be given to waiving this requirement for ships fitted with a dynamic positioning system.

3.3.3 Bow/stern/submerged turret loading instrumentation is to be provided as follows:

- (a) Indicator for loading connector coupling position.
- (b) Cargo valve position indicators.
- (c) Cargo tank level indicators and high level alarm.
- (d) A system for automatic transfer of signals from the control and safety system, to enable personnel on the offshore terminal to effect control of cargo transfer pump(s) and closing of valve(s) on the terminal.

3.4 Emergency disconnect arrangements for pipeline and mooring

3.4.1 In addition to any automatic disconnection systems, a manually operated backup emergency disconnection system is to be provided. This system is to make possible individual operation of the chain stopper and coupling by-pass locks located in the bow control station.

3.4.2 Where an emergency quick-release system is fitted for the mooring system, an equivalent arrangement is to be provided to release the cargo loading hose outboard of the ship.

3.5 Communication

3.5.1 Main and emergency means of communication are to be provided between the bow control station and the offshore loading terminal. The communication equipment is to be intrinsically-safe.

3.5.2 Continuous communication is to be maintained between the control station and the offshore terminal at all times.

■ **Section 4** **Fire protection, detection and extinction**

4.1 General

4.1.1 The fire protection and extinction arrangements are to comply with the requirements of the *SOLAS - International Convention for the Safety of Life at Sea*, as amended, or as required by the National Authority.

4.1.2 When Lloyd's Register (hereinafter referred to as 'LR') is authorised to act on behalf of the National Authority in giving effect to the fire safety measures on non-convention tankers or the application of *SOLAS - International Convention for the Safety of Life at Sea* for convention ships, LR will also apply the *MSC/Circular.474 – Guidelines for Bow and Stern Loading and Unloading Arrangements on Oil Tankers – (Adopted on 9 May 1988)*, dated 19 June 1987.

4.1.3 Tankers of less than 500 gross tons will be specially considered.

■ **Section 5** **Piping systems**

5.1 Materials

5.1.1 All materials used in the piping systems are to be suitable for use with the intended cargoes and ambient weather conditions, and are to comply with the relevant requirements of *Pt 5, Ch 12 Piping Design Requirements* and the applicable requirements of the *Rules for the Manufacture, Testing and Certification of Materials, July 2015*.

5.2 Piping system design

5.2.1 All piping, valves and fittings are to be suitable for the design operating and environmental conditions.

5.2.2 The piping is to comply with the requirements for manufacture, testing and certification of Class II piping systems.

5.2.3 The pipelines and associated piping systems and equipment forward and/or aft of the cargo area are to have only full penetration butt welded joints, except at the loading station where valve connections may be flanged. The pipes are not to pass through enclosed spaces and are to be, as far as possible, self-draining.

5.2.4 Means of mechanical isolation are to be provided in the cargo area, where any pipes used for cargo handling are branched off from the cargo system. Such isolation is to be as near as possible to the boundary of the aftmost, in the case of stern loading, or forwardmost, in the case of bow loading, cargo tank bulkhead and within the cargo area.

5.2.5 A manually operated shut-off terminal valve is to be provided at the manifold. In addition, a blank flange, or equivalent arrangement, is to be provided at the bow and/or stern pipe line end connection.

5.2.6 The terminal pipe, valves and other fittings to which the cargo hose is directly connected are to be of steel or other approved ductile material. They are to be of robust construction, adequately supported and suitable for the stated design conditions. Attention is drawn to the *Recommendations for Oil Tanker Manifolds and Associated Equipment*, published by OCIMF.

5.2.7 Means of emptying, cleaning, inerting and gas-freeing the pipe lines used for cargo handling are to be provided. The venting arrangements are to be located in the cargo deck area. Isolation similar to that described in *Pt 7, Ch 6, 5.2 Piping system design 5.2.4* is also to be provided.

5.2.8 A drip tray of adequate size, together with means of drainage, are to be provided at the manifold. Suitable spray shields are to be fitted in way of the terminal manifolds where leakage may occur at valves and pipe joints.

5.2.9 Zones on open deck within 3 m of loading manifolds or pipe joints, and within 3 m of the spillage drip tray, are to be regarded as hazardous with regard to machinery or other equipment which could constitute a possible source of ignition, see also *Pt 6, Ch 2, 14.5 Hazardous zones and spaces* and *Pt 6, Ch 2, 14.10 Requirements for tankers intended for the carriage in bulk of oil cargoes having a flash point not exceeding 60°C (closed-cup test)*.

5.2.10 Air vent pipes to the tanks and enclosed spaces, and mechanical ventilation outlets are to be located as far as possible, but in no case less than 3 m, from the terminal manifold or the nearest barrier of the spillage drip tray, whichever is closer.

5.3 Piping system testing and non-destructive examination

5.3.1 Testing and non-destructive examination of the piping system is to comply with the relevant requirements for Class II piping.

■ Section 6 Trials and testing

6.1 General

6.1.1 The arrangements and equipment referred to in this Chapter are to be examined and tested on completion of the installation, including calibration of coupling equipment.

6.1.2 Examination and testing is to include witnessing of the initial hook-up trials and the implementation of operational procedures for the range of actions covered by the Operating Manual.

Section

- 1 **General**
- 2 **Coal storage, handling, ash collection and disposal arrangements**
- 3 **Coal burning equipment**
- 4 **Ship structure**
- 5 **Electrical equipment**
- 6 **Control engineering systems**
- 7 **Fire protection and extinction**

■ Section 1 General

1.1 Application

1.1.1 The requirements of this Chapter apply to ships using coal as a primary source of heat for the generation of steam for main and essential auxiliary services.

1.1.2 The relevant requirements of the Rules and those of the National Authority with whom the ship is registered, together with any special requirements of the Administration within whose territorial jurisdiction the ship is intended to operate, are to be complied with. Attention is drawn to the statutory requirements concerning intact and damaged stability of the ship.

1.1.3 For the purpose of these requirements, it is assumed that no manual handling of coal for the transportation from bunkers to boiler, or for actual firing of the boiler, will be employed. The emphasis has been placed on the presumption that the boiler firing will be by some form of moving grate. Special consideration will be given to other forms of firing, such as pulverised fuel, slurries of coal-oil-water mixtures or fluidised bed firing, if submitted.

1.1.4 For single main boiler installation, see *Pt 5, Ch 3, 5.3 Single main boiler*.

1.2 Submission of plans

1.2.1 The plans and information required by *Pt 7, Ch 7, 1.2 Submission of plans 1.2.2 to Pt 7, Ch 7, 1.2 Submission of plans 1.2.4* are to be submitted in triplicate for consideration.

1.2.2 General arrangement plans and specification of the storing, handling and burning equipment and ash handling plant.

1.2.3 Structural plans showing details and arrangements in way of coal bunkers, and support arrangements for coal handling and ash disposal plants.

1.2.4 A general arrangement plan showing details of construction, fire protection and extinction for coal bunkers and coal handling systems, supplemented as necessary, by detailed plans and calculations for fire-extinguishing, explosion suppression, temperature monitoring and carbon monoxide detection systems.

1.3 Surveys

1.3.1 Coal bunkering, coal handling, burning and ash disposal plants are to be built, installed, and tested under operating conditions to the Surveyors' satisfaction and subsequently at each Boiler Survey. Fire-extinguishing, explosion suppression, temperature monitoring and carbon monoxide detection systems are to be installed and tested to the Surveyors' satisfaction and subsequently examined annually as required by *Pt 1, Ch 3, 2.2 Annual Surveys*.

1.4 Additional bilge drainage

1.4.1 It should be noted that, under the provision of *SOLAS - International Convention for the Safety of Life at Sea*, additional bilge drainage is required for passenger ships burning coal, as detailed in *Pt 7, Ch 7, 1.4 Additional bilge drainage 1.4.2* and *Pt 7, Ch 7, 1.4 Additional bilge drainage 1.4.3*.

1.4.2 In passenger ships there shall be provided in the boiler room, in addition to the other suctions required by the Rules, a flexible suction hose of suitable diameter and sufficient length capable of being connected to the suction side of an independent power pump.

1.4.3 In passenger ships where there is no watertight bulkhead between the engine and the boiler spaces, a direct discharge overboard or, alternatively, a by-pass shall be fitted from any circulating pump discharge used for emergency bilge pumping duties.

■ Section 2

Coal storage, handling, ash collection and disposal arrangements

2.1 Coal storage

2.1.1 The arrangements for coal bunkers, including hatchways, ventilation, monitoring and their design characteristics regarding intact and damaged stability are to comply with the requirements detailed in *Pt 7, Ch 7, 4 Ship structure* and *Pt 7, Ch 7, 7 Fire protection and extinction*, as applicable.

2.1.2 Coal is to be stored in not less than two bunkers. Vessels on restricted routes having a voyage time less than the capacity of the daily service hoppers, or where the boiler has the alternative means of firing, or where alternative means of propulsion are fitted, may be provided with only one bunker.

2.1.3 The clearance spaces between the boilers, other heated surfaces and the coal bunkers are to be adequate for the free circulation of air necessary to avoid transmission of heat to the coal.

2.1.4 A daily service storage hopper is to be provided for each coal-fired boiler.

2.1.5 Coal bunkers and daily service storage hoppers are to be designed to avoid dead spots and areas where coal can accumulate and impede the normal flow or can provide the conditions to promote spontaneous combustion.

2.1.6 Bunker and daily service storage hopper outlet gravity-fed discharges are to be provided with shut-off devices. Stopping the transfer device will be acceptable in lieu where a bunker delivers to transfer arrangements and stopping the transfer device effectively prevents flow from the bunker, see *Pt 7, Ch 7, 2.2 Coal handling 2.2.4*.

2.1.7 Shut-off devices on the coal bunker and daily service storage hopper outlets are to be capable of being operated locally and also from an accessible position outside the compartment in which they are situated.

2.1.8 The arrangements for loading coal into bunkers or during transfer into daily service storage hoppers should, in general, avoid the tendency of the coal to segregate. For this purpose multiple loading points should be used if necessary.

2.2 Coal handling

2.2.1 Each daily service storage hopper is to be provided with a separate system for transferring coal from the bunker(s). In the case of a single boiler installation, more than one transfer system from the bunker(s) to the daily service storage hopper are to be provided, unless alternative means of firing the boiler is available.

2.2.2 Adequate access facilities are to be provided in the coal feeder systems to permit maintenance and removal of blockages.

2.2.3 Where coal screens or crushers are necessary for the efficient operation of the coal burning equipment, they are to be provided in each boiler coal feed arrangement.

2.2.4 The coal handling plant is to be capable of being stopped locally and from an accessible position outside the compartment in which it is situated, see *Pt 7, Ch 7, 2.1 Coal storage 2.1.6*.

2.2.5 The use of milling systems for the production of pulverised fuel will be specially considered.

2.3 Ash collection and disposal arrangements

2.3.1 Each coal fired boiler is to be provided with a bottom ash and fly ash collecting and disposal arrangement.

2.3.2 Where both bottom ash and fly ash collecting and disposal arrangements are operated by either pneumatic or water systems, then these may be made common.

2.3.3 Two independent means of supplying the operating medium for ash collection and disposal systems are to be provided.

2.3.4 Heated ash storage and transfer systems are to be efficiently lagged to minimise risk of fire and to prevent damage by heat.

2.3.5 Where wet ash water transfer systems are used, consideration is to be given to the effects of corrosion and erosion on the collection, transfer and storage equipment.

2.3.6 Ash transfer systems employing water separation arrangements are to be such that water will drain naturally back to the de-watering bins or into a collection tank. Such drainage facilities should not, in general, be led direct to bilge wells.

2.3.7 Where a dry ash collection system is proposed, the arrangement of conveyors, pipes and chutes should avoid condensation due to excessive cooling to prevent solidification of the ash.

2.3.8 Adequate ash storage capacity, with access facilities to permit maintenance and removal of blockages, is to be provided for systems using boilers which have no alternative means of firing. Certain National Authorities or local Administrations prohibit the direct discharge of ash overboard.

■ *Section 3* **Coal burning equipment**

3.1 Operating conditions

3.1.1 The design and arrangements for coal burning equipment are to be such that it can be manually controlled from a suitable position local to the boiler fronts.

3.1.2 Burning arrangements for solid fuel firing:

- (a) The arrangements should permit a sufficient level of control of coal feed to the grates or bed to avoid uneven firing conditions likely to cause damage to the grate or bed, due to excessive heat or coal build-up, under all operating conditions.
- (b) In addition to the adequate supplies of air for efficient combustion, sufficient capacity and means of control of the combustion air supply below the grates or beds are to be provided to ensure cooling of the grate or bed under all conditions of coal or alternative means of firing.
- (c) When the coal bed is not fully incandescent, i.e. during low steaming conditions when coal-fired beds are banked or reduced in output, sufficient purging sequences to sweep the furnace volumes are to be provided before any alternative means of firing is attempted.

3.1.3 Where it is proposed to provide means of firing the boiler simultaneously on coal and oil, details of the arrangements for furnace purging and ignition of oil burners are to be submitted and will be the subject of special consideration.

3.2 Forced and induced draught air fans

3.2.1 In boilers fitted with forced and induced draught fans, suitable bias is to be maintained to avoid gas leakage into the boiler room.

3.2.2 In the event of induced draught fan failure, the forced draught fan should be arranged to stop automatically. Alternative arrangements which will permit the forced draught fan to be controlled to reduce the supply of air may be considered.

3.3 Fuel characteristics and specification

3.3.1 In general, the coal burning equipment is to be designed to utilise the various grades of coal likely to be encountered.

3.4 Alternative means of firing

3.4.1 Where it is proposed to use an alternative means of firing, such as oil or coal/oil slurry mixtures, the arrangements are to be in accordance with the requirements for oil burning, *see Pt 5, Ch 14 Machinery Piping Systems*.

3.4.2 Particular attention is drawn to the requirements concerning arrangements for securely locking up-take dampers in the fully open position when burning fuel oil.

3.4.3 Where it is proposed to use fuel oil burners for lighting up coal fires, details are to be submitted of the pre-purging sequences of the boiler before lighting-up burners are introduced into the furnace.

3.4.4 Where it is proposed to employ lighting-up burners using diesel oil or similar marine distillate fuels, they are to be provided with their own combustion air supply.

3.4.5 Where it is proposed to use steam purging or steam atomising oil burners with coal fired boilers, particular attention is to be given to furnace purging arrangements. Details of the purging sequences are to be submitted.

3.4.6 The arrangements for purging the oil burners are to be such that the minimum practicable volume of oil will be introduced into the boiler furnace.

■ Section 4 Ship structure

4.1 General

4.1.1 The requirements of this Section are additional to those given in other parts of these Rules and in separate Rules for specific ship types.

4.1.2 Other than as permitted in *Pt 7, Ch 7, 4.3 Coal bunker bulkheads 4.3.2*, separation between coal bunkers and adjacent spaces is to be gastight. In oil or chemical tankers, coal bunkers are to be separated from cargo tanks by means of cofferdams.

4.1.3 Boiler room access doors are to comply with *Pt 3, Ch 11, 6.4 Companionways, doors and accesses on weather decks*, as applicable.

4.1.4 Coaling ports on the side shell are to comply with parts of *Pt 3, Ch 11, 8 Side and stern doors and other shell openings* as applicable.

4.1.5 No side scuttles are to be fitted in spaces appropriated exclusively for the carriage of coal.

4.1.6 All openings from coal bunkers are to be located clear of the defined hazardous area for the particular ship type.

4.2 Coal bunker hatchways

4.2.1 Coal bunker hatchways are to be provided with gasketed steel covers and coamings, complying with *Pt 3, Ch 11 Closing Arrangements for Shell, Deck and Bulkheads*, as applicable.

4.2.2 Coal bunker hatchways are to be located clear of the defined hazardous area for the particular ship type.

4.3 Coal bunker bulkheads

4.3.1 The scantlings of main coal bunker boundary bulkheads which are counted towards the number of bulkheads required by *Pt 3, Ch 3, 4 Bulkhead requirements*, or which form the boundary of deep tanks, are to satisfy the requirements of *Pt 4, Ch 1, 9 Bulkheads*. Other boundaries are to satisfy the requirements of *Pt 4, Ch 1, 9 Bulkheads*, but the load head may be taken to the top of the bunker. The scantlings of cofferdam bulkheads not forming the boundaries of a cargo tank in oil or chemical tankers are to satisfy the requirements of *Pt 4, Ch 9, 7 Transverse oiltight bulkheads*. In all cases when flooding is envisaged as a means of fire-extinction, the moduli of stiffening members on bunker bulkhead boundaries are to be increased by 25 per cent.

4.3.2 Where the coal bunker is situated immediately forward of the engine room, the aft coal bunker bulkhead may be non-watertight. The scantlings for this bulkhead are to be as required for watertight bulkheads (*Pt 4, Ch 1, 9 Bulkheads*) but the load head may be taken to the top of the tank. With this arrangement, the forward end of the coal bunker may, if appropriate, be regarded as the engine room forward bulkhead.

4.3.3 The thickness of the plating in way of the bulkhead knuckles in the region of the hoppers and the plating of the hopper apexes is to be increased by 1,5 mm over that derived from *Pt 7, Ch 7, 4.3 Coal bunker bulkheads 4.3.1* and *Pt 7, Ch 7, 4.3 Coal bunker bulkheads 4.3.2*. However, the minimum thickness of the lowest strake in the coal hopper is to be not less than 9 mm. Where solid stainless steel is employed, the plate thickness may be reduced by 10 per cent or 1 mm, whichever is the lesser.

4.3.4 Non-watertight coal bunker bulkhead scantlings are to be as required by *Table 1.4.8 Non-watertight pillar bulkheads in Pt 4, Ch 1 General Cargo Ships*, but the thickness of the lowest strake is to be not less than 9 mm.

4.3.5 The scantlings of the boundaries of compartments intended for the storage of ash in liquid or slurry form will be specially considered.

4.3.6 Watertight doors may be fitted in watertight bulkheads between permanent and reserve bunkers, and may be of the sliding, hinged or equivalent type. They are to be accessible at all times, see also *Pt 3, Ch 11, 9 Watertight doors in bulkheads below the freeboard deck*.

4.3.7 Arrangements are to be made by means of screens or otherwise to prevent the coal from interfering with the closing of watertight doors.

4.4 Longitudinal strength

4.4.1 For the purpose of longitudinal strength, the requirements for the relevant ship types are to be applied.

4.4.2 The calculation of still-water shear forces and bending moments are to cover both departure and arrival conditions, and any special mid-voyage conditions caused by variation in coal bunkering and ballast distribution. Details of typical coal stowage rates are to be submitted, as well as trim and stability data for these conditions.

4.4.3 Where local reduction of double bottom depth is proposed to accommodate coal handling equipment, the strength of the double bottom and scarfing arrangements will require special consideration. Adequate scarfing of longitudinal material in way of double bottom and hopper tanks should be arranged.

4.5 Ventilation

4.5.1 Ventilators serving coal bunkers or boiler rooms are to comply with *Pt 3, Ch 12, 2 Ventilators* as applicable. In addition, the atmosphere in the bunkers is to be sampled by means of fixed or portable monitors as follows:

- (a) prior to entering the space – for oxygen deficiency,
- (b) prior to opening the hatchways – for accumulation of flammable gases.

4.5.2 Ventilator exits from main coal bunkers and coal processing spaces are to discharge clear of the defined hazardous area for the particular ship type and not less than 3 m from the nearest intake or opening to accommodation and enclosed working spaces, and from possible source of ignition.

■ *Section 5* **Electrical equipment**

5.1 General

5.1.1 All electrical equipment should be situated in positions where it is not exposed to concentration of coal dust. Where this is not practicable, the enclosure of the equipment should be designed and installed such that:

- (a) Dust cannot enter the interior of the enclosure. An ingress protection rating of at least I.P. 55 in accordance with IEC Publication 60529, if not of a safe-type, is considered to be acceptable.
- (b) Dust will not collect on the surface of the enclosure to such an extent that proper cooling is prevented, thus causing a dangerous rise in temperature.
- (c) The maximum surface temperature of the enclosure is not capable of igniting the dust, and should be limited to 165°C for equipment not subjected to overloading and 120°C for equipment such as motors, that may be overloaded.

5.2 Arrangements in coal bunkers

5.2.1 Electrical equipment located within the coal bunkers is to be of a safe-type certified for Group II A atmospheres and temperatures Class T1 in accordance with IEC Publication 60079, *Electrical Apparatus for Explosive Atmospheres*, or an equivalent National Standard.

5.2.2 The switches and protective devices for such equipment are to interrupt all lines or phases and are to be located outside the coal bunker spaces. Provision is to be made for the complete isolation of these circuits and locking the means of control in the off position.

■ **Section 6**
Control engineering systems

6.1 General

6.1.1 The requirements of *Pt 6, Ch 1 Control Engineering Systems* are applicable. The additional requirements for boilers which are coal grate-fired and under normal operation are remotely controlled or are automatic in operation, are given in *Table 7.6.1 Coal burning: Alarms and safeguards*.

6.1.2 In general, ships complying with the relevant requirements of *Pt 6, Ch 1, 4 Unattended machinery space(s) - UMS notation* or *Pt 6, Ch 1, 5 Machinery operated from a centralised control station - CCS notation* will be eligible for the notations **UMS** (unattended machinery space) or **CCS** (centralised control station) respectively.

Table 7.6.1 Coal burning: Alarms and safeguards

Item	Alarm	Note
Drum water level	Low	Combustion air; coal spreaders and/or any alternative fuel supply to be shut-off automatically
Daily service hopper level	High/Low	—
Coal feed plant	Failure	—
Primary combustion air system	Failure	Coal spreaders to be stopped automatically
Secondary combustion air system	Failure	—
Coal supply controller (if separate from spreader)	Failure	Per controller
Spreader drive	Failure/ Overload	Per drive. See also primary combustion air system failure
Grate drive	Failure/ Overload	Per drive
Localised overheating of the grate	Excessive	—
Induced draught fan	Failure	Coal spreaders to be stopped automatically, see also <i>Pt 7, Ch 7, 3.2 Forced and induced draught air fans 3.2.2</i>
Ash disposal system	Failure	—

Note Interlocks are to be provided to prevent the burning of fuel oil, unless dampers in the gas passages of uptakes have been securely locked in the fully-open position, see also *Pt 7, Ch 7, 3.4 Alternative means of firing 3.4.2*.

■ *Section 7***Fire protection and extinction****7.1 Fire protection**

7.1.1 In general, the coal bunkers are to be separated from adjacent spaces by 'AO' divisions, but where such spaces are intended to contain highly flammable substances, such as the cargo tanks of an oil tanker, they are to be separated from the coal bunkers by a cofferdam or equivalent space.

7.1.2 The spaces above the coal in the coal bunkers and coal processing spaces are to be adequately ventilated to prevent the accumulation of flammable gases. The ventilators are to be provided with means of closure which are readily accessible at all times. Where mechanical ventilation is provided, means are to be provided for stopping the fans from a position which will be readily accessible at all times.

7.2 Fire-extinction

7.2.1 A fixed fire-extinguishing system should be provided in the coal bunkers. This system should discharge CO₂, but alternative arrangements such as water flooding will be considered, *see also Pt 7, Ch 7, 4.3 Coal bunker bulkheads*.

7.2.2 Where, due to operating conditions, it is considered likely that coal dust in significant quantities will be present in the coal crushing and conveying system, an explosion suppression system is to be provided in the coal crushing and conveying system. Activation of the explosion suppression system is to operate an audible and visual alarm.

7.2.3 A fixed fire-extinguishing system should be provided in the ready-use coal hopper and this should be extended to the boiler room, if there is any danger of the spread of fire to that space. The system should depend on CO₂, but alternative extinguishing media will be considered. Where it can be shown that the residence time, of the coal in the hopper, is of sufficiently short duration that a fire in the hopper is unlikely to be sustained, consideration will be given to dispensing with this requirement.

Positional Mooring and Thruster-Assisted Positional Mooring Systems

Section

- 1 **General**
- 2 **Environmental criteria - Forces and motions**
- 3 **Mooring system - design and analysis**
- 4 **Mooring equipment**
- 5 **Anchor winches and windlasses**
- 6 **Electrical and control equipment**
- 7 **Thruster-assisted positional mooring**
- 8 **Thruster-assisted mooring - Classification notation requirements**
- 9 **Trials**

■ Section 1 General

1.1 Application

1.1.1 The requirements of this Chapter apply to Lloyd's Register (hereinafter referred to as 'LR') classed ships with positional mooring systems or thruster-assisted positional mooring systems and are additional to those applicable in other Parts of the Rules. The Rules are not intended to apply to vessels which have station-keeping capabilities, but which are not required to remain on station in adverse weather conditions. This normally precludes the Rules being applicable to small ships.

1.1.2 Compliance with this Chapter is not mandatory, but ships provided with a positional mooring system or thruster-assisted positional mooring system which do comply will be eligible for an appropriate class notation which will be recorded in the *Register Book* at the specific request of an Owner.

1.1.3 The mooring system will be considered for classification with LR on the basis of operating constraints and procedures specified by the Owner and recorded in the Operations Manual.

1.1.4 Requirements, additional to these Rules may be imposed by the National Authority with whom the ship is registered and/or by the administration within whose territorial jurisdiction it is intended to operate.

1.2 Classification notations

1.2.1 Ships provided with a positional mooring system which complies with the requirements of this Chapter will be eligible to have included in the class notation one of the following special features notations:

(a) For ships fitted with a positional mooring system:

PM (Positional mooring system); or

PMC (Positional mooring system for mooring in close proximity to other ships or installations. This notation will apply in particular to any ship operating in conjunction with a fixed installation, e.g. crane barge, accommodation unit, maintenance vessel, etc.)

(b) For ships fitted with a thruster-assisted positional mooring system:

PM [T1circ] [or [T2circ] or [T3circ]]

or

PMC [T1circ] [or [T2circ] or [T3circ]]

The numeral in the circled supplementary notation, [T1circ], etc. defines the thruster allowance which may be permitted in the design of the positional mooring system, and is determined by the capacity/redundancy of the thrust/machinery installation, see *Table 8.3.2 Thruster allowance*.

Positional Mooring and Thruster-Assisted Positional Mooring Systems

1.2.2 Additional descriptive notes may be given and entered in column 6 of the *Register Book* indicating the type of positional mooring system, reference system, control system, limiting environmental criteria, etc.

1.3 Surveys

1.3.1 The positional mooring and thruster-assisted positional mooring systems and their associated equipment are to be examined and tested during construction and under working conditions on completion of the installation. The Periodical Survey of these items is to be arranged to coincide with Hull and Machinery Surveys as required by other Parts of these Rules.

1.4 Definitions

1.4.1 Positional mooring is a method of station keeping by means of multiple anchor lines laid out in catenary array. Each positional mooring system is to consist of the following:

- (a) Anchors or anchor piles.
- (b) Anchor lines.
- (c) Anchor line fittings (shackles, connecting links, wire rope terminations, quick release devices, etc.).
- (d) Fairleads.
- (e) Winches or windlasses.
- (f) Chain or wire rope stoppers.

Where applicable, the structural or mechanical connection of these items to the ship is also considered to be part of the positional mooring system.

1.4.2 'Thruster-assisted Mooring' is the use of thrusters and main propulsion, if so designed, to supplement the ship's anchoring system.

1.5 Plans and data submission

1.5.1 The information and plans specified in *Pt 7, Ch 8, 1.5 Plans and data submission 1.5.2* to *Pt 7, Ch 8, 1.5 Plans and data submission 1.5.5* are to be submitted in triplicate. One copy of the Operations Manual referred to in *Pt 7, Ch 8, 1.5 Plans and data submission 1.5.6* is to be forwarded for information.

1.5.2 Plans and data dealing with positional mooring arrangements and the associated equipment are to be submitted, including the following:

- (a) Mooring arrangements with details of mooring patterns, anchor lines and fittings, etc.
- (b) Mooring equipment with details of anchors, fairleads and cable stoppers.
- (c) Winches or windlasses with details of gearing shafting, brake systems, ratchet and pawl, drum/cable lifter and frame.

1.5.3 For thruster-assisted positional mooring systems, plans of the following, together with particulars of ratings, in accordance with the relevant Parts of these Rules are to be submitted for the following:

- (a) Prime movers, gearing, shafting, propellers and thrust units, *see also Pt 5, Ch 8 Shaft Vibration and Alignment*.
- (b) Machinery piping systems.
- (c) Electrical installations.

In addition, details of proposals for the redundancy provided in machinery, electrical installations and control systems are to be submitted. These proposals are to take account of the possible loss of performance capability should a component fail. Where a common power source is utilised for thrusters, details of the total maximum load required for thruster-assist are to be submitted.

1.5.4 Plans of control, alarm and safety systems, including the following, are to be submitted:

- (a) Functional block diagrams of the control system(s).
- (b) Functional block diagrams of the position reference systems and the environmental sensors.
- (c) Details of the electrical supply to the control system(s), the position reference system(s) and the environmental sensors.
- (d) Details of the monitoring functions of the controllers, sensors and reference system, together with a description of the monitoring functions.
- (e) List of equipment with identification of the manufacturer, type and model.
- (f) Details of the overall alarm system linking the centralised control station, subsidiary control stations, relevant machinery spaces and operating areas.
- (g) Details of the control stations, e.g. control panels and consoles, including the location of the control stations.

Positional Mooring and Thruster-Assisted Positional Mooring Systems

Part 7, Chapter 8

Section 2

(h) Test schedules which are to include the methods of testing and the test facilities provided.

1.5.5 The following supporting plans, data, calculations or documents are to be submitted:

- (a) General arrangement showing plan views, side elevations and sections of the ship.
- (b) Design criteria showing operating and survival environment, water depth range and required station keeping limits.
- (c) Environmental forces on ship showing wind, current and wave drift. These forces are to be verified by direct calculation, model test reports, or full-scale data, etc.
- (d) Ship motions showing first order wave motions, surge, sway and yaw. Tank test data or equivalent to be provided.
- (e) Mooring analysis, including computer printout where relevant.
- (f) Strength calculations for anchors, fairleads, winches/ windlasses, cable stoppers and special fittings.
- (g) Thruster arrangements for thruster-assist systems, including powers, thrusts and interactions between thrusters, thruster and hull, thruster and current.

1.5.6 An Operations Manual for the system is to be placed on board the ship. This Manual is to contain all necessary information and instructions regarding positional mooring and, where relevant, thruster-assisted positional mooring. It would normally also contain descriptions of the following:

- Mooring systems.
- Laying the mooring system.
- Anchor pre-loading.
- Pre-tensioning anchor lines.
- Tension adjustment.
- Winch performance.
- Winch operation.
- Procedure in event of failure or emergency.
- Procedure for operating thrusters.
- Fault-finding procedures for thruster-assist system.

■ Section 2

Environmental criteria - Forces and motions

2.1 Limiting environmental criteria

2.1.1 Limiting criteria in the form of maximum operating and survival environmental conditions are to be specified by the Owner or Designer.

2.1.2 The limiting criteria are to be defined in terms of wind and current speeds, wave heights and periods, and water depth range.

2.1.3 As water depth will have a large influence on a ship's mooring capability, the limiting environmental criteria may be varied according to water depth.

2.1.4 **Maximum operating conditions** will be those in which the ship is able to carry out its primary operational activities, while anchor line tensions remain within designated operating limits. See Pt 7, Ch 8, 3.2 *Design cases and factors of safety* for required factors of safety in operating conditions.

2.1.5 **Survival conditions** are to be based on an average recurrence period of not less than 50 years. The mooring system is to be such that maximum line tensions will be limited in these conditions to designated survival levels. See Pt 7, Ch 8, 3.2 *Design cases and factors of safety* for required factors of safety.

2.2 Design environmental criteria

2.2.1 **Wind.** The design wind speed for wind force determination can normally be taken as the one-hour mean value referenced to 10 m above sea level. Account is to be taken of the variation of wind speed with height above sea level. The wind velocity gradient can be calculated from the following:

$$V_H = V_{10} \left(\frac{H}{10} \right)^{0,125}$$

where

V_H = wind velocity at H height above sea level

V_{10} = 1 hour mean wind speed referenced to 10 m above sea level.

2.2.2 **Current.** The design current speed is to be taken as the sum of wind-induced and tidal current velocities. For calculation purposes, tidal current velocity can be assumed constant over water depth, and wind-induced current velocity can be taken to reduce linearly from its maximum value at the surface to zero at 50 m below sea level.

2.2.3 **Wave.** The significant wave height and period range is to be defined for each relevant design case.

2.3 Environmental forces

2.3.1 In determining environmental forces, it is to be assumed that the defined limiting environment of wind, waves and current will act concurrently. For fixed azimuth mooring systems, these forces are considered to act in the same direction.

2.3.2 Environmental loading on the ship (and the corresponding catenary system motions analysis to determine anchor loads and line tensions, etc.) will require to be investigated for a sufficient number of directions to establish the critical cases.

2.3.3 It is generally to be assumed that the maximum specified environmental conditions can come from any direction relative to the ship's heading. However, in cases where a ship is to be restricted to specific defined locations, consideration will be given to the acceptance of an environmental rosette (allowing the ship to be headed in the most favourable direction with respect to mooring loads).

2.3.4 Where quasi-static methods of analysis are adopted (see Pt 7, Ch 8, 3.1 General 3.1.2), at least the wind, current, and mean wave drift forces acting on the ship in the various relevant design conditions are to be calculated or determined. In addition, any significant yawing moments induced by these effects are to be taken into account when carrying out the mooring system motions analysis.

2.3.5 Environmental forces and moments can be determined by suitable methods of direct calculation or by model testing. In either case, account must be taken of all significant load generating structural elements or equipment. In the case of wind force and moment determination, all deck structures, fittings, cranes, towers, superstructures, etc. are to be considered, and for current force, account is to be taken of thrusters, nozzles, propellers, etc.

2.3.6 First order wave motions – the oscillatory motions of the ship – are to be determined. Surge and sway are the most relevant motions in terms of quasi-static mooring analysis, see Pt 7, Ch 8, 3.1 General 3.1.2 and Figure 8.3.1 Quasi-static analysis.

2.3.7 The first order wave motions of the ship are to be determined from appropriate wave spectra, either by use of tank testing or by suitable direct calculation methods.

2.3.8 Account is to be taken of the effects of shallow water on the ship's first order wave motions.

■ Section 3

Mooring system - design and analysis

3.1 General

3.1.1 The positional mooring system is to be designed to meet the specified limiting environmental criteria (see Pt 7, Ch 8, 2.1 Limiting environmental criteria), and any associated operational constraints (restricted offset of ship, etc.) as contained in the Operations Manual.

3.1.2 This Section in general, and the anchor line factors of safety in particular, relate principally to the quasi-static approach to mooring analysis. This method of analysis takes wind, current and wave drift forces to be steady effects which will displace the moored ship from its original equilibrium position to a new mean position where the mooring system will have developed sufficient restoring force to 'balance' the steady applied force. Wave-induced oscillatory vessel motions take place about this new mean

position. In quasi-static analysis, maximum anchor line tensions are taken to occur at the extremity of vessel offset, see also Figure 8.3.1 *Quasi-static analysis*.

3.1.3 Consideration will be given to the adoption of alternative methods of design for the mooring system, including the use of part-dynamic or full-dynamic analysis techniques. In such cases, factors of safety, etc. will be specially considered.

3.1.4 For ships which intend to utilise thruster assistance, as an aid to position-keeping or as a means of reducing anchor line tensions, the extent of thruster allowance which is permitted in calculations is given in Table 8.3.2 *Thruster allowance*.

3.1.5 Anchor line length is to be sufficient to avoid uplift forces occurring at the anchors in the worst damaged survival condition.

3.1.6 Account is to be taken in the mooring analysis of the elastic stretch of anchor lines.

3.2 Design cases and factors of safety

3.2.1 The design cases which require to be considered, and the associated minimum anchor line factors of safety are given in Table 8.3.1 *Minimum anchor line factors of safety*.

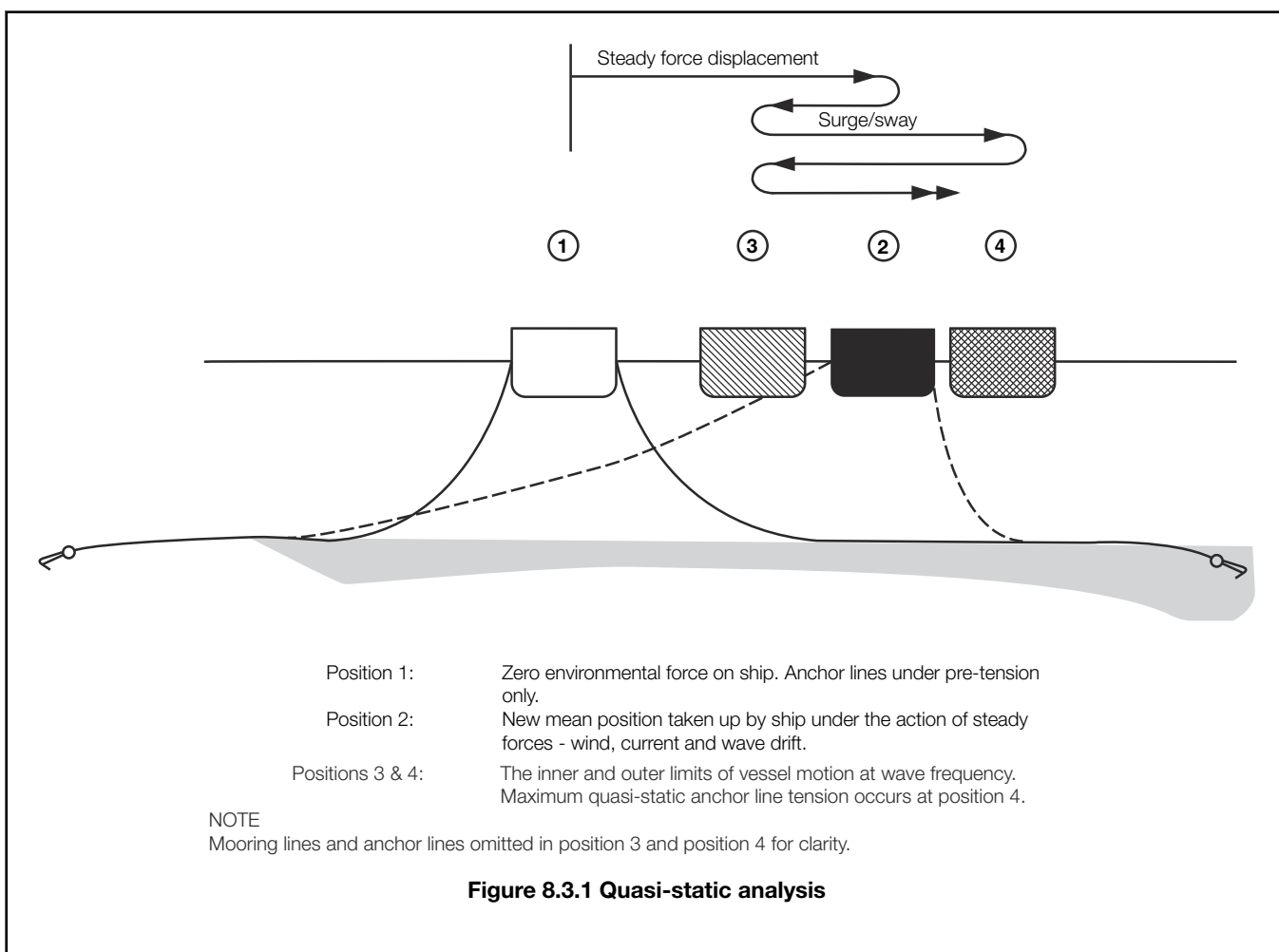

Positional Mooring and Thruster-Assisted Positional Mooring Systems

Table 8.3.1 Minimum anchor line factors of safety

Design Case	Description	Factor of safety	
		Class notation	
		PM, PM(T1) etc.	PMC, PMC (T1)
1	Operating – Intact The ship in an operating mode with its mooring system intact, subject to specified operating constraints (limiting environment and permissible offset of the ship).	2,7	3,0
2	Survival – Intact The ship in survival mode with mooring system intact, subject to maximum (survival) environmental conditions.	1,8	2,0
3	Operating – Damaged As Case 1, but with loss of restraint of any one anchor line, <i>see also</i> Note 3.	1,8	2,0
4	Survival – Damaged As Case 2, but with loss restraint of any one anchor line.	1,25	2,0/1,4 (See Note 5)

Note 1. In the context of this Chapter, Cases 1 and 2 ('Intact' Cases) refer to the mooring system with all anchor lines intact. Cases 3 and 4 ('Damaged' Cases) refer to the mooring system with the loss of any one anchor line.

Note 2. Anchor line factor of safety = $\frac{\text{Minimum rated break strength}}{\text{Maximum line tension}}$

Note 3. The factors of safety given in *Table 8.3.1 Minimum anchor line factors of safety* are to be based on maximum line tensions resulting from steady force offset of the ship, plus maximum first order wave motion. In Design Cases 3 and 4, the factors relate to the ship in its post-damage settled position, following the loss of restraint from an anchor line, (i.e. neglecting transient effects, but see Note 4).

Note 4. In addition to the 'static' considerations in Design Cases 3 and 4 (see Note 3), account is also to be taken of transient vessel motions following anchor or line failure. The motion path taken by the vessel in moving to a new static equilibrium position is to be determined for each line breakage case to ensure that:

- (a) The ship maintains adequate clearance from any adjacent installation (applicable where **PMC** or **PMC (T1)** etc. notation is to be assigned). A minimum dimensional clearance of 10 m will normally be required.
- (b) The ship remains within its required operational excursion limits.
- (c) Successive line failures will not occur. In calculating factors of safety, the maximum anchor line tensions in this case are to be those resulting from the extreme point of transient motion, with the ship subject to steady force and significant wave motion.

Note 5. The factor of safety of 2,0 applies to critical lines maintaining separation between the moored ship and an adjacent installation.

Table 8.3.2 Thruster allowance

Case	Thruster allowance		
	(T1)	(T2)	(T3)
Operating (Intact)	None	70% of all thrusters, less one	All thrusters, less one
Survival (Intact)	70% of all thrusters	All thrusters	All thrusters
Operating (Damaged)	None	70% of all thrusters, less one	All thrusters, less one

Survival (Damaged)	70% of all thrusters	All thrusters	All thrusters
<p>Note 1. The conditions for assignment of supplementary notations , (T1), (T2) and (T3) are defined in <i>Pt 7, Ch 8, 8 Thruster-assisted mooring - Classification notation requirements</i>.</p> <p>Note 2. Where all thrusters are permitted, the net effect of all thrusters can be included in calculations.</p> <p>Note 3. Where all thrusters except one are permitted, the net effect of all thrusters, less the single most effective one, can be included in calculations.</p>			

■ Section 4 Mooring equipment

4.1 Anchors

4.1.1 Anchors for positional mooring are to be sufficient in number and holding power, and are to have adequate structural strength, for the intended service. It is the Owners'/ Operators' responsibility to ensure adequate anchor holding power for each location or holding ground.

4.1.2 The anchors are to be of an approved type. Supporting calculations to verify the structural strength of the anchor under proof test loading are to be submitted.

4.1.3 The anchors are to be manufactured in accordance with the requirements of *Ch 10 Equipment for Mooring and Anchoring of the Rules for the Manufacture, Testing and Certification of Materials, July 2015* (hereinafter referred to as the Rules for Materials).

4.1.4 The anchors are to be proof tested in the manner laid down in *Ch 10 Equipment for Mooring and Anchoring of the Rules for Materials*. The level of proof test loading for positional mooring anchors is to be the greater of the following:

- (a) 50 per cent of the minimum rated break strength of the intended anchor line; or
- (b) the value given in *Table 10.1.1 Proof load tests for anchors (see Notes 1 and 2) in Rules for the Manufacture, Testing and Certification of Materials, July 2015* of the Rules for Materials.

4.2 Fairleads

4.2.1 Fairleads are to be designed to permit free movement of the anchor line in all mooring configurations. *Figure 8.4.1 Minimum operating range and design loading of fairlead* shows the minimum operating range of the fairlead to be considered in conjunction with the design load.

4.2.2 Fairleads and their supporting structures are to be designed for a load equivalent to the rated minimum break strength of the anchor line.

4.2.3 Maximum allowable stresses for the design criteria given in *Pt 7, Ch 8, 4.2 Fairleads 4.2.1* and *Pt 7, Ch 8, 4.2 Fairleads 4.2.2* are to be based on the following factors of safety:

Shear	1,89	Factors relate to tensile yield stress
Tension, compression or bending	1,25	Factors relate to tensile yield stress
Combined	1,11	Factors relate to tensile yield stress

$$(\text{combined stress} = \sqrt{\sigma_X^2 + \sigma_Y^2 - \sigma_X \sigma_Y + 3 \tau^2})$$

Where σ_X and σ_Y are the combined axial and bending stresses in the X and Y directions respectively and τ is the combined shear stress due to torsion and/or bending in the X-Y plane.

4.2.4 Materials and steel grades are generally to comply with the requirements given in *Pt 7, Ch 8, 5.2 Materials* for Type P components.

4.2.5 Chain cable fairleads are to have a minimum of five pockets.

4.2.6 Wire rope fairleads are generally to have a minimum diameter of 20 times the wire rope diameter.

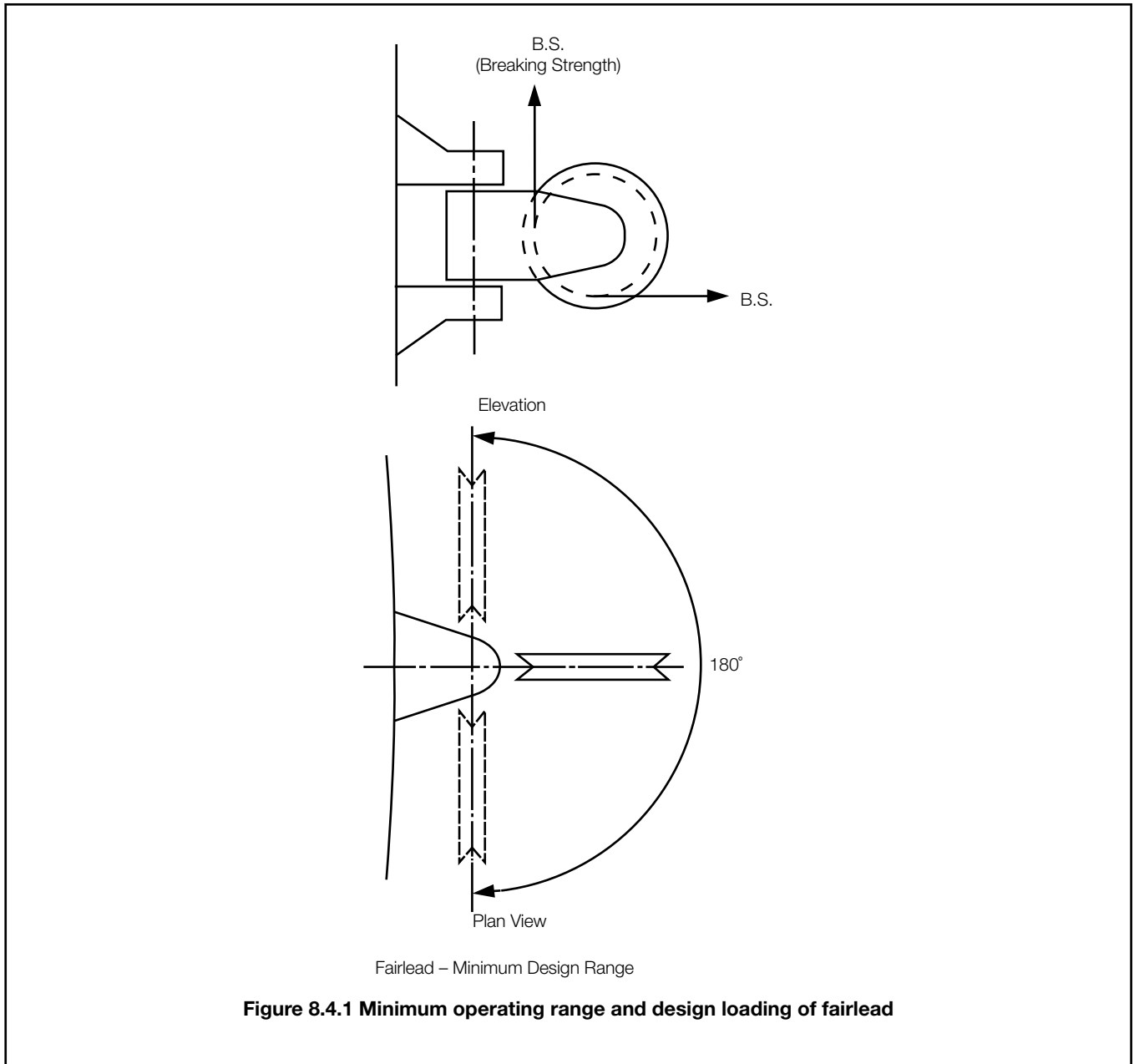

4.3 Stoppers

4.3.1 Stoppers may require to be provided depending on the winch arrangements, see Pt 7, Ch 8, 5 Anchor winches and windlasses.

4.3.2 Where stoppers are fitted, they are to comply with Pt 7, Ch 8, 5 Anchor winches and windlasses in respect to mechanical and strength aspects, and Pt 7, Ch 8, 6 Electrical and control equipment for release arrangements.

4.4 Anchor lines

4.4.1 Anchor lines are generally to be of stud link chain cable, steel wire rope or a combination of both. Special consideration will be given to proposals for the use of alternative materials.

4.4.2 Stud link chain cable is to be either of unified grade (U2 or U3) meeting the requirements of *Ch 10 Equipment for Mooring and Anchoring* of the Rules for Materials, or an approved special grade.

4.4.3 Wire rope for anchor lines is to have a suitable construction for its purpose (6 x 37 construction with independent wire rope core is generally acceptable).

4.4.4 Steel wire ropes are generally to comply with *Ch 10, 5 Short link chain cables* of the Rules for Materials, or with an equivalent recognised National or International Standard.

4.4.5 Wire rope terminal fittings are to comply with an acceptable code or standard. The strength of terminations, connecting fittings, shackles or links is not to be less than that of the anchor line.

■ Section 5

Anchor winches and windlasses

5.1 General

5.1.1 Machinery items are to be constructed, installed and tested in accordance with the relevant requirements of *Pt 5 Main and Auxiliary Machinery*. For electrical and control equipment, see *Pt 7, Ch 8, 6 Electrical and control equipment*.

5.2 Materials

5.2.1 Materials are generally to comply with the requirements of *Pt 5, Ch 1, 2.2 Materials*.

5.2.2 Components have been categorised in this Section as Type P (Primary) and Type S (Secondary) for material selection purposes.

(a) **Type P:** Components where failure would result in the loss of a primary function of the winch or windlass, e.g.:

Winch drum.

Windlass cable lifter.

Reduction gears.

Shafts.

Brakes.

Pawl stoppers.

Bedplates.

NOTE

Consideration will be given to designating any of the above components as Type S (see below), provided adequate redundancy of operation exists.

(b) **Type S:** Secondary, stressed items, not categorised as Type P, and where failure would not result in the loss of a primary winch function.

5.2.3 Steel materials for Type P or Type S components are generally to comply with the following Chapters and Sections of the Rules for Materials:

(a) Plates and bars: *Ch 3 Rolled Steel Plates, Strip, Sections and Bars Ch 3, 1 General requirements* and *Ch 3, 2 Normal strength steels for ship and other structural applications*, *Ch 3, 3 Higher strength steels for ship and other structural applications* or *Ch 3, 6 Ferritic steels for low temperature service*, as appropriate.

(b) Castings: *Ch 4, 1 General requirements* and *Ch 4, 7 Ferritic steel castings for low temperature service*.

(c) Forgings: *Ch 5, 1 General requirements* and *Ch 5, 8 Ferritic steel forgings for low temperature service*.

Consideration will be given to the acceptance of suitable equivalent National Standards.

5.2.4 Material grades are to be selected to provide the necessary notch toughness. See *Table 8.5.1 Material grades* for suitable Grades.

5.2.5 The requirements of *Pt 7, Ch 8, 5.2 Materials 5.2.3* and *Pt 7, Ch 8, 5.2 Materials 5.2.4* apply where the minimum design air temperature is within the range 0°C to minus 15°C. Requirements for design temperatures outside this range will be subject to special consideration.

5.2.6 For components such as gears, shafts and boltings made from rolled or forged bar materials not subject to welding, the material composition and heat treatment, etc. may be submitted for approval as an alternative to the requirements of *Table 8.5.1 Material grades*.

5.2.7 Non-ductile materials are not to be used for torque transmitting items or for those elements subject to tensile/bending stresses.

5.2.8 Spheroid graphite iron castings are to comply with *Ch 7, 3 Spheroidal or nodular graphite iron castings* of the Rules for Materials, Grades 370/17 or 400/12, or to an equivalent National Standard.

5.2.9 The use of grey iron castings will be subject to special consideration. Where approved, they are to comply with the requirements of *Ch 7, 2 Grey iron castings* of the Rules for Materials. This material is not to be used for gear components.

5.2.10 Brake lining materials are to be compatible with operating environmental conditions.

5.3 Brakes

5.3.1 Each anchor winch or windlass is required to have one primary braking system and one secondary braking system. The two systems are to operate independently.

5.3.2 The braking action of the motor unit may be used for secondary braking purposes where the design is suitable.

5.3.3 A residual braking force of at least 50 per cent of the maximum braking force required by *Pt 7, Ch 8, 5.5 Winch/Windlass performance 5.5.1* is to be immediately available and automatically applied in the event of a power failure.

5.4 Stoppers

5.4.1 If the winch motor is to be used as a secondary brake, then a stopper is to be provided to take the anchor line load during maintenance of the primary brake.

5.4.2 The stopper may be one of two different types – a pawl stopper fitted at the cable lifter/drum shaft, or a stopper acting directly on the anchor line.

5.4.3 Where the stopper acts directly on the cable, its design is to be such that the cable will not be damaged by the stopper at a load equivalent to the rated breaking strength of the cable.

5.4.4 See also *Pt 7, Ch 8, 6.2 Control stations 6.2.1* and *Pt 7, Ch 8, 6.2 Control stations 6.2.2* for stopper control station requirements, and *Pt 7, Ch 8, 6.4 Controls 6.4.5* for emergency release of stoppers.

Table 8.5.1 Material grades

Component type	Thickness (mm)	Grade					
		Plate		Castings		Forgings	
		AW (see Note 1)	PWHT (see Note 2)	AW	PWHT	AW	PWHT

Positional Mooring and Thruster-Assisted Positional Mooring Systems

Part 7, Chapter 8 Section 5

P	$t \leq$	D, DH32, DH36	AH, B	C-Mn	C-Mn	LT20	LT0
	$25 < t \leq 50$	E, EH32, EH36	DH32, DH36	C-Mn	C-Mn	LT40	LT20
	$50 < t \leq 60$	E, EH32, EH36	E, EH32, EH36* (See Note 5)	C-Mn	C-Mn	LT40	LT40 (See Note 5)
	$60 < t \leq 80$	LT60 (See Note 3)	E, EH32, EH36	$2\frac{1}{4}$ Ni (See Note 3)	C-Mn	LT60 (See Note 3)	LT40
	$80 < t \leq 100$	LT60	LT60 (See Note 3)	$2\frac{1}{4}$ Ni	$2\frac{1}{4}$ Ni (See Note 3)	LT60	LT60 (See Note 3)
	$100 < t \leq 130$	(See Note 4)	LT60	$3\frac{1}{2}$ Ni	$2\frac{1}{4}$ Ni	(See Note 4)	LT60
	$130 < t \leq 160$	$1\frac{1}{2}$ Ni	(See Note 4)	(See Note 7)	(See Note 7)	$1\frac{1}{2}$ Ni	(See Note 4)
S	$t \leq 60$	DH32, EH36	Not normally applied (See Note 6)				
	$60 < t \leq 80$	E, EH32, EH36* (See Note 5)					
	$80 < t \leq 100$	E, EH32, EH36					
	$100 < t \leq 130$	LT60 (See Note 3)					
	$130 < t \leq 160$	LT60					
<p>Note 1. AW. Without post-weld heat treatment.</p> <p>Note 2. PWHT. With post-weld heat treatment or not welded.</p> <p>Note 3. Impact test temperature may be raised to -50°C.</p> <p>Note 4. Use either $\frac{1}{2}$Ni or $1\frac{1}{2}$Ni with impact test at -70°C.</p> <p>Note 5. Impact test temperature may be raised to -30°C.</p> <p>Note 6. If PWHT is used, grades will be specially considered.</p> <p>Note 7. To be specially considered.</p>							

5.5 Winch/Windlass performance

5.5.1 The primary brake is required to hold a static load equal to the minimum break strength of the anchor line (at the intended outer working layer of wire rope on storage drum winches). The static load capacity of the primary brake can be reduced to 80 per cent of that value when a stopper capable of holding 100 per cent of the breaking strength of the line is fitted.

5.5.2 The secondary brake is required to hold a static load equal to 50 per cent of the minimum breaking strength of the anchor line.

5.5.3 The anchor winch or windlass is to have adequate dynamic braking capability. The two brake systems in joint operation are to be capable of fully controlling, without overheating, the anchor lines during:

- (a) all anchor handling operations;
- (b) adjustment of anchor line tensions. (This is particularly relevant where the mooring system has been designed and sized, on the basis of active adjustment of anchor lines in extreme conditions, to minimise line tensions).

5.5.4 See also Pt 7, Ch 8, 6.2 Control stations for control of winches, windlasses, stoppers and pawls, and Pt 7, Ch 8, 6.4 Controls for brake fail safe requirements and standby power for operation of brakes and release of stoppers in the event of a failure of normal power supply.

5.5.5 The pulling force of the winches or windlasses is to be sufficient to carry out anchor pre-loading on location, to the necessary level. A minimum low-speed pull equal to 40 per cent of the anchor line breaking strength is recommended.

5.6 Strength

5.6.1 Design load cases for the winch or windlass assembly and the stopper when fitted are given in *Table 8.5.2 Design load cases*. The associated maximum allowable stresses are to be based on the factors of safety given in *Table 8.5.3 Safety factors for design load cases*.

Table 8.5.2 Design load cases

Load case	Condition	Anchor line load percentage of break strength
1	Winch braked	100% (See Note)
2	Stopper engaged	100%
3	Winch pulling	40% or specified duty pull if greater

Note Where stopper is fitted, anchor line load in Case 1 can be taken as brake slipping load, but is not to be less than 80 per cent break strength

Table 8.5.3 Safety factors for design load cases

Stress	Load case	
	1 & 2	3
	Factor of safety	
Shear	1,89	2,5
Tension, compression, bending	1,25	1,67
Combined	1,11	1,43

Note 1. Factors of safety relate to tensile yield stress.

Note 2. Combined stress = $\sqrt{\sigma_X^2 + \sigma_Y^2 - \sigma_X \sigma_Y + 3 \tau^2}$
 Where σ_X and σ_Y are the combined axial and bending stresses in the X and Y directions respectively and τ is the combined shear stress due to torsion and/or bending in the X–Y plane.

5.7 Testing

5.7.1 Works tests are to be carried out in the presence of the Surveyor, on at least one of the winch or windlass units out of the total outfit for the vessel. The tests to be carried out are given in *Table 8.5.4 Works test*. Alternatively, where a prototype winch has been suitably tested, consideration will be given to the acceptance of these results.

Table 8.5.4 Works test

Test	Test load
Static brake — Primary	100% Anchor line break strength (or 80% where stopper fitted. See Pt 7, Ch 8, 5.5 Winch/Windlass performance 5.5.1)
Static brake — Secondary	50% Anchor line break strength
Stopper (where fitted)	100% Anchor line break strength
Motor stall test	Specified stall load

5.7.2 The residual braking capability (see *Pt 7, Ch 8, 5.5 Winch/Windlass performance 5.5.4*) is to be verified.

5.7.3 Each winch or windlass is to be tested on board the vessel, in the presence of the Surveyor, to demonstrate that all main aspects, including dynamic brakes, function satisfactorily. The proposed test programme is to be submitted.

5.8 Type approval

5.8.1 Winches or windlasses may be type approved in accordance with LR's Type Approval Scheme. Where this type approval is obtained, the requirements of *Pt 7, Ch 8, 5.7 Testing 5.7.1* may not be applicable.

Section 6

Electrical and control equipment

6.1 General

6.1.1 The electrical installation is to be designed, constructed and installed in accordance with the relevant requirements of *Pt 6, Ch 2 Electrical Engineering*.

6.1.2 Control, alarm and safety systems are to be designed, constructed and installed, in accordance with the relevant requirements of *Pt 6, Ch 1 Control Engineering Systems*, together with the requirements of *Pt 7, Ch 8, 6.2 Control stations to Pt 7, Ch 8, 6.4 Controls*.

6.2 Control stations

6.2.1 The operation of winches, windlasses and associated brakes, chainstoppers and pawls is to be controlled locally from weather-protected control stations which provide good visibility of the equipment and associated anchor handling operations.

6.2.2 A central control station, which may be located on the bridge or a separate manned control room, is to be provided from which brakes, chainstoppers and pawls can be remotely released.

6.2.3 For each anchor winch, the respective local control station is to be provided with a means of indicating the following:

- (a) Line tension.
- (b) Length of line paid out.
- (c) Line speed.

6.2.4 The indication required by *Pt 7, Ch 8, 6.2 Control stations 6.2.3* and *Pt 7, Ch 8, 6.2 Control stations 6.2.3* is to be repeated to the central control station and, in addition, a means of indicating the following is to be provided at this position:

- (a) Mooring patterns and anchor line catenaries.
- (b) Status of winch operation.
- (c) Position and heading, see also *Pt 7, Ch 8, 6.4 Controls 6.4.6*.
- (d) Gangway angle and extension, when applicable.
- (e) Riser angle, when applicable.
- (f) Wind speed and direction, see also *Pt 7, Ch 8, 6.4 Controls 6.4.9*.

6.2.5 Means of voice communication are to be provided between the central control station, each local control station and anchor handling vessels, when applicable.

6.3 Alarms

6.3.1 Alarms are to be provided at the local and central control stations for the following fault conditions:

- (a) Excessive line tension.
- (b) Loss of line tension.
- (c) Excessive gangway angle and extension, when applicable.
- (d) Excessive riser angle, when applicable.

6.3.2 Alarms are to be provided adjacent to the winches and windlasses to warn personnel prior to and during any remote operation.

6.3.3 Alarms are to be provided at the central control station for the following fault conditions:

- (a) When the ship deviates from its predetermined area of operation.
- (b) When the ship deviates from its predetermined heading limits.

These alarms are to be adjustable, but should not exceed specified limits. Arrangements are to be provided to fix and identify their set points.

6.4 Controls

6.4.1 Adequate controls are to be provided at the local control station for satisfactory operation of the winch(es).

6.4.2 The braking system is to be arranged so that the brakes, when applied, are not released in the event of a failure of the normal power supply.

6.4.3 Standby power is to be provided to enable winch brakes to be released within 15 seconds in an emergency. The release arrangements are to be operable locally at each winch and from the central control position, and are to be such that the entire anchor line can be lowered in a controlled manner.

6.4.4 The standby power is to be such that, during lowering of the anchor line, it is possible to apply the brakes once and then release them again in a controlled manner.

6.4.5 Standby power is to be provided, so that any anchor line stoppers or pawl mechanisms may be released from either the local or central control stations up to a line tension equal to the minimum rated break strength of the anchor line. These mechanisms are to be capable of release at the maximum angles of heel and trim under the damage stability and flooding conditions for which the ship is designed.

6.4.6 At least one position reference system and one gyrocompass or equivalent is to be provided, when applicable, to ensure the specified area of operation and heading deviation can be effectively monitored.

6.4.7 Position reference systems are to incorporate suitable position measurement techniques which may be by means of acoustic devices, radio, radar, taut wire, riser angle, gangway extension and angle or other acceptable means depending on the service conditions for which the ship is intended.

6.4.8 A vertical reference sensor is to be provided, if applicable, to measure the pitch and roll of the ship.

6.4.9 Means are to be provided to ascertain the wind speed and direction acting on the ship.

■ Section 7

Thruster-assisted positional mooring

7.1 General

7.1.1 When the positional mooring system is supplemented by thrusters, the requirements of *Pt 7, Ch 4 Dynamic Positioning Systems*, are to be generally complied with in respect of the machinery, electrical and control engineering arrangements. In applying these requirements, the arrangements for the notations **DP(CM)**, **DP(AM)** and **DP(AA)** may be regarded as equivalent to those for supplementary notations [T1circ] [T2circ] and [T3circ] respectively, unless otherwise stated in this Chapter.

7.2 Control systems

7.2.1 Suitable processing and comparative techniques are to be provided at the central control station to validate the control system inputs, thereby ensuring optimum performance of the thruster-assisted mooring system.

7.2.2 Abnormal signal errors revealed by the validity checks required by *Pt 7, Ch 8, 7.2 Control systems 7.2.1* are to initiate alarms.

7.2.3 The control system is to be stable throughout its operational range and is to meet the specified performance and accuracy criteria.

7.2.4 An alarm is to be provided for a control computer system fault.

7.2.5 Sufficient instrumentation is to be fitted at the central control station to ensure effective control and indicate that the system is functioning correctly, *see also Pt 7, Ch 8, 6.2 Control stations*.

7.2.6 The deviation from the desired heading and/or position is to be adjustable, but should not exceed the specified limits. Arrangements are to be provided to fix and identify the set points for the desired heading and/or position.

■ Section 8 Thruster-assisted mooring - Classification notation requirements

8.1 Notations

8.1.1 For assignment of notation **(T1)**, the applicable requirements of *Pt 7, Ch 8, 6 Electrical and control equipment* and *Pt 7, Ch 8, 7 Thruster-assisted positional mooring*, together with *Pt 7, Ch 8, 8.1 Notations 8.1.2*, are to be complied with.

8.1.2 Centralised automated manual control of the thrusters is to be provided to supplement the position mooring system. The manual control system is to provide output signals to the thrusters, via the manual controller, to change the speed, pitch and azimuth angle, as applicable, thereby optimising line tension, as indicated at the central control station, see *Pt 7, Ch 8, 6.2 Control stations 6.2.4*.

8.1.3 For assignment of notation **(T2)**, the applicable requirements of *Pt 7, Ch 8, 6 Electrical and control equipment* and *Pt 7, Ch 8, 7 Thruster-assisted positional mooring*, together with *Pt 7, Ch 8, 8.1 Notations 8.1.4* to *Pt 7, Ch 8, 8.1 Notations 8.1.7* are to be complied with.

8.1.4 Automatic and manual control systems are to be provided to supplement the positional mooring systems and arranged to operate independently, so that failure in one system will not render the other system inoperative. See also *Pt 7, Ch 8, 8.1 Notations 8.1.2* for manual control.

8.1.5 The automatic control system is to utilise automatic input(s) from the position reference system, the environmental sensors and line tensions, and automatically provide output signals to the thrusters to change the speed, pitch and azimuth angle, as applicable, thereby optimising line tension.

8.1.6 In the event of line failure or failure of the most effective thruster, the ship is to be capable of maintaining its predetermined area of operation and desired heading in the environmental conditions for which the ship is designed and/or classed.

8.1.7 Control, alarm and safety systems are to incorporate a computer-based consequence analysis, which may be continuous or at predetermined intervals, and is to analyse the consequence of predetermined failures to verify that the anchor line tensions and position/heading deviations remain within acceptable limits. In the event of a possible hazardous condition arising as a result of the consequence analysis, an alarm is to be initiated at the central control station.

8.1.8 For assignment of notation **(T3)**, the applicable requirements of *Pt 7, Ch 8, 6 Electrical and control equipment* and *Pt 7, Ch 8, 7 Thruster-assisted positional mooring*, together with *Pt 7, Ch 8, 8.1 Notations 8.1.5* to *Pt 7, Ch 8, 8.1 Notations 8.1.7* and *Pt 7, Ch 8, 8.1 Notations 8.1.9* to *Pt 7, Ch 8, 8.1 Notations 8.1.12*, are to be complied with.

8.1.9 Two automatic control systems are to be provided and arranged to operate independently, so that failure in one system will not render the other system inoperative.

8.1.10 In the event of failure of the working system, the standby automatic control system is to be arranged to changeover automatically without manual intervention and without any adverse effect on the ship's station keeping capability. The automatic changeover is to initiate an alarm.

8.1.11 At least two position reference systems, as defined by *Pt 7, Ch 8, 6.4 Controls 6.4.7*, are to be provided.

8.1.12 At least two of each of the environmental sensors, as required by *Pt 7, Ch 8, 6.4 Controls 6.4.8* and *Pt 7, Ch 8, 6.4 Controls 6.4.9*, are to be provided.

■ *Section 9*
Trials

9.1 General

9.1.1 Before a new installation (or any alteration or addition to an existing installation) is put into service, trials are to be carried out. These trials are in addition to any acceptance tests which may have been carried out at the manufacturers' works and are to be based on the approved test schedules list as required by *Pt 7, Ch 8, 1.5 Plans and data submission 1.5.4*.

9.1.2 The suitability of the positional mooring and/or thruster-assisted positional mooring system is to be demonstrated during sea trials, observing the following:

- (a) Response of the system to simulated failures of major items of control and mechanical equipment, including loss of electrical power.
- (b) Response of the system under a set of predetermined manoeuvres for changing:
 - (i) Location of area of operation.
 - (ii) Heading of the ship.
- (c) Automatic thruster control and line tension optimisation.
- (d) Monitoring and consequence analyses.
- (e) Simulation of line breakage and damping.
- (f) Continuous operation of the thruster-assisted positional mooring system over a period of four to six hours.

9.1.3 Two copies of the test schedules, as required by *Pt 7, Ch 8, 1.5 Plans and data submission 1.5.4*, signed by the Surveyor and Builder, are to be provided on completion of the survey. One copy is to be placed on board the ship and the other submitted to LR.

Section

- 1 **General requirements**
- 2 **Physical conditions**
- 3 **Workstations**
- 4 **Systems**
- 5 **Integrated Bridge Navigation System – IBS notation**
- 6 **Trials**

■ Section 1 General requirements

1.1 General

1.1.1 The requirements of this Chapter apply to ships where an optional class notation for optimizing environment on the bridge for navigational tasks, including periodic operation of the ship under the supervision of a single watchkeeper on the bridge and/or integrated bridge systems, is requested, and are additional to those applicable in other Parts of the Rules.

1.1.2 The requirements of this Chapter are based on the understanding that the *International Regulations for Preventing Collisions at Sea* and all other relevant Regulations relating to Radio Communications and Safety of Navigation required by *Chapter IV - Radiocommunications* and *Chapter V - Safety of navigation* respectively of SOLAS are complied with.

1.1.3 Requirements additional to those in this Chapter may be imposed by the National Authority with whom the ship is registered and/or by the Administration within whose territorial jurisdiction it is intended to operate.

1.1.4 The requirements of this Chapter are framed on the understanding that contingency plans for emergencies are specified and the conditions under which one man watch is permitted are clearly defined in an operations manual which is acceptable to the Administration with which the ship is registered.

1.1.5 In general, ships complying with the requirements of *Pt 7, Ch 9, 1 General requirements* to *Pt 7, Ch 9, 4 Systems* of this Chapter will be eligible for the notation **NAV1**.

1.1.6 *Pt 7, Ch 9, 5 Integrated Bridge Navigation System – IBS notation* of this Chapter states additional requirements which shall apply where the navigational functions are integrated. In general, ships complying with the requirements of *Pt 7, Ch 9, 5 Integrated Bridge Navigation System – IBS notation* will be eligible for the notation **IBS**, see *Pt 1, Ch 2, 2.4 Class notations (machinery)*. In addition to the assessment of the navigational function integration, the assignment of the notation **IBS** requires that the layout of the bridge and the equipment located on the bridge is to the satisfaction of Lloyd's Register (hereinafter referred to as LR), see *Pt 7, Ch 9, 5.2 General requirements 5.2.1*.

1.2 Information and plans required to be submitted

1.2.1 The following information and plans are to be submitted in triplicate:

- For programmable electronic systems, the plans required by *Pt 6, Ch 1, 1.2 Documentation required for design review 1.2.6*.
- Details of the intended area of operation of the ship.
- List of navigational equipment detailing manufacturer, and model and National Authority approval (where applicable).
- Functional block diagrams and descriptions of the navigational equipment, internal communications systems and watch safety system indicating their relationship to each other.
- Details of the electrical power supplies to the navigational equipment, internal communications systems, watch safety system, and clear view arrangements.
- A general arrangement of the ship showing the fields of vision from the bridge.
- A general arrangement of the bridge and wheelhouse showing the positions of consoles, panels, handrails, seating, windows and clear view arrangements.

- A profile view of the wheelhouse detailing the inclination of windows, heights of upper and lower edges of windows, and dimensions of consoles.
- Detailed arrangements of consoles and panels showing the layout of equipment.
- Test schedules which should include methods of testing and test facilities provided.
- A schedule of the electrical and electronic equipment referred to in *Pt 7, Ch 9, 2.2 Environment 2.2.10* giving details of:
 - equipment description;
 - manufacturer;
 - type and/or model; and
 - evidence of electromagnetic compatibility.

1.3 Definitions

1.3.1 The following definitions are applicable to these Rules:

(a) **Workstation:**

A position at which one or several tasks, constituting a particular activity, is carried out.

(b) **Navigation workstation:**

A workstation at which the navigator may carry out all tasks relevant for deciding, executing and maintaining course and speed in relation to waters and traffic. The instrumentation and controls at the navigation workstation should allow the navigator to:

- analyse the traffic situation;
- monitor position, course, track, speed, time, propeller revolutions and pitch, rudder angle, depth of water, rate of turn, and wind speed and direction;
- alter course and speed;
- effect internal and external communications;
- give and receive sound signals;
- control navigational lights;
- monitor and acknowledge navigational alarms and warnings;
- confirm his well-being and watch-keeping awareness; and
- record navigational data.

(c) **Main steering position:**

That part of the navigation workstation where those controls and instrumentation relevant to controlling the ship's course are located.

(d) **Conning position:**

A place on the bridge which is used by navigators when commanding, manoeuvring and controlling a ship.

(e) **Voyage planning workstation:** A workstation at which the navigator may carry out the following tasks without affecting the actual navigation of the vessel:

- examine and update charts and other relevant documentation;
- plan a voyage as a series of waypoints, courses, speeds and turns;
- calculate an estimated time of arrival at various points on the voyage; and
- determine and plot the ship's position.

■ Section 2

Physical conditions

2.1 Bridge and wheelhouse arrangement

2.1.1 The bridge configuration, arrangement of consoles and equipment location are to be such as to enable the officer of the watch to perform navigational tasks and other functions allocated to the bridge, as well as maintain an effective lookout. The following tasks are to be supported:

- navigation and manoeuvring;
- monitoring;
- manual steering;
- docking;
- planning;
- safety;
- communications; and
- conning.

2.1.2 Equipment and associated displays and indicators are to be sited at clearly defined workstations.

2.1.3 Consoles, including the chart table, are to be positioned, so that the instrumentation they contain is mounted in such a manner as to face a person looking forward. As far as practicable, operating surfaces are to be normal to the operator's line of sight.

2.1.4 From other workstations within the wheelhouse it is to be possible to monitor the navigation workstation and to maintain an effective lookout.

2.1.5 The main access to the bridge is to be by means of an internal stairway. Secondary external access is also to be provided.

2.1.6 Clear passage of at least 700 mm width is to be available to allow movement around the bridge with a minimum of inconvenience. Particular attention is to be paid to the following routes which are to be as direct as possible:

- (a) From bridge wing to bridge wing, a clear passage of at least 1200 mm in width.
- (b) Between the internal entrance to the bridge and the route in *Pt 7, Ch 9, 2.1 Bridge and wheelhouse arrangement 2.1.6 a* a clear passage of at least 700 mm in width is to be provided.
- (c) Between adjacent workstations, a clear passage of at least 700 mm is to be provided.
- (d) Between the bridge front bulkhead or any consoles and installations placed against the front bulkhead, to any consoles or installations placed away from the bridge front, a clear passage of at least 800 mm is to be provided.

Space necessary for operating at a workstation is to be considered as part of the workstation and is not to be part of the passageway.

2.1.7 The clear height between the wheelhouse deck surface covering and the underside of the deckhead is to be at least 2250 mm. The lower edge of deckhead mounted equipment is to be at least 2100 mm in open areas, passageways and at standing workstations.

2.1.8 Toilet facilities are to be provided on the bridge or adjacent to the bridge on the bridge deck.

2.2 Environment

2.2.1 The bridge is to be free of physical hazards to personnel. There are to be no sharp edges or protuberances and wheelhouse, bridge wing and upper bridge decks are to be free of trip hazards and have non-slip surfaces whether wet or dry.

2.2.2 Sufficient hand-rails or equivalent are to be fitted inside the wheelhouse and around workstations to enable personnel to move or stand safely in bad weather. Protection of stairway openings is to be given special consideration.

2.2.3 Provision for seating is to be made in the wheelhouse. Means for securing the seating are to be provided having regard to storm conditions.

2.2.4 Glare and reflections from surfaces are to be minimised. In this respect, walls, ceilings, consoles, chart tables and other major fittings are to be provided with a suitable low reflective finish. Arrangements are to be provided to prevent the obscuration of information presented on visual display units and instruments which are fitted with transparent covers.

2.2.5 Entrance doors to the wheelhouse are to be securable from the inside, and operable with one hand. Bridge wing doors are not to be self-closing, and are to be provided with means to hold them open. For ships required to comply with the *Rules and Regulations for the Construction and Classification of Ships for the Carriage of Liquefied Gases in Bulk*, the sealing mechanism of each door is to be such that a rapid and efficient gas and vapour tightening can be ensured.

2.2.6 An adequate air conditioning or mechanical ventilation system, together with sufficient heating according to climatic conditions, is to be provided in order to maintain the temperature of the wheelhouse within the range of 14°C to 30°C and the humidity within the range 20 per cent to 60 per cent. The discharge of hot or cold air is not to be directed towards bridge personnel. Control of this system is to be provided in the wheelhouse.

2.2.7 The noise level on the bridge is not to interfere with verbal communication, mask audible alarm signals, or be uncomfortable to bridge personnel. In this respect, the ambient noise level in the wheelhouse in good weather is not to exceed 65 dB(A).

2.2.8 A sound reception system or alternative means is to allow external sound signals to be heard and their direction determined within the wheelhouse.

2.2.9 Permanently installed electrical and electronic equipment is to be installed so that electromagnetic interference does not affect the proper function of the navigational systems and equipment. Installation of the equipment in accordance with the guidelines and recommendations included in IEC 60533: *Electrical and electronic installations in ships – Electromagnetic compatibility*, or an acceptable equivalent Standard, would generally be considered to meet the requirement.

2.2.10 Permanently installed electrical and electronic equipment, on the bridge and in the vicinity of the bridge, that is not subject to the approval required by *Pt 7, Ch 9, 3.1 Navigation workstation 3.1.13*, is to have undergone electromagnetic compatibility testing that demonstrates the equipment satisfies the conducted and radiated emission requirements of:

- IEC 60533: *Electrical and electronic installations in ships – Electromagnetic compatibility*; or
- IEC 60945: *Maritime navigation and radio communication equipment and systems – General requirements – Methods of testing and required test results*.

Testing in accordance with other appropriate standards is subject to consideration and details are to be submitted.

2.2.11 To demonstrate compliance with *Pt 7, Ch 9, 2.2 Environment 2.2.10*, a schedule of applicable equipment is to be compiled, see *Pt 7, Ch 9, 1.2 Information and plans required to be submitted 1.2.1*. Where it is proposed to add to or modify the equipment referred to in *Pt 7, Ch 9, 2.2 Environment 2.2.10* the schedule is to be maintained accordingly, see also *Pt 7, Ch 9, 6.1 General 6.1.1*. A copy of the schedule documentation is to be placed on board the vessel and a copy is to be made available to the LR Surveyor on request.

2.2.12 Passive electromagnetic equipment, considered not liable to cause or be susceptible to electromagnetic disturbances, may be provided with an exemption statement in place of evidence of electromagnetic compatibility for the purposes of *Pt 7, Ch 9, 2.2 Environment 2.2.11*. Examples of passive electromagnetic equipment include cables, purely resistive loads and batteries.

2.3 Lighting

2.3.1 The level of lighting is to enable bridge personnel to perform all bridge tasks, including maintenance and chart and office work, by day and night. Controls, indicators, instruments, keyboards, etc. on the bridge are to be capable of being seen in the dark, either by means of internal lighting within the equipment or the wheelhouse lighting system. A satisfactory level of flexibility within the lighting system is to be available to enable the bridge personnel to adjust the lighting in brightness and direction as required in different areas of the bridge and by the needs of individual instruments and controls.

2.3.2 All illumination and lighting of instruments, keyboards and controls are to be adjustable down to zero, except the lighting of alarm and warning indicators and the controls of dimmers which are to remain readable.

2.3.3 Two separate circuits are to be provided for wheelhouse lighting, such that failure of any one of the circuits does not leave the space in darkness, see *Pt 6, Ch 2, 5.7 Lighting circuits*.

2.3.4 Emergency lighting is to be provided for the wheelhouse, stairways and exits, see *Pt 6, Ch 2, 3 Emergency source of electrical power*.

2.3.5 Lighting used in areas and at items of equipment requiring illumination, whilst the ship is navigating, is to be such that night vision is not impaired, e.g. red lighting. Such lighting is to be arranged, so that it cannot be mistaken for a navigation light by another ship, and to prevent glare and stray image reflections.

2.3.6 In order to avoid possible confusion in colour discrimination, red lighting is not to be fitted over chart tables.

2.3.7 To avoid unnecessary light sources in the front area of the bridge, only instruments necessary for the safe navigation and manoeuvring of the ship are to be located in this area.

2.3.8 Means are to be provided to prevent the sudden flooding of light onto the bridge from alleyways, accommodation areas and the chart table area.

2.3.9 Deck and superstructure lights which may impair safe navigation are to be controlled from the bridge.

2.3.10 Each navigation light is to be provided with an audible and visual alarm to indicate failure of the light, see *Pt 6, Ch 2, 15.6 Navigation lights*.

2.3.11 Means are to be provided to test alarm and other indicator lamps.

2.4 Windows

2.4.1 All wheelhouse windows are to be constructed of shatterproof toughened glass having a strength commensurate with the degree of exposure of the bridge to storm conditions and complying with a recognised National or International Standard, e.g. ISO 21005, *Ships and marine technology – Thermally toughened safetyglass panes for windows and side scuttles*.

2.4.2 Windows are to be as wide as possible and divisions between them are to be kept to a minimum. No division is to be positioned immediately forward of any workstation or on the ship's centreline.

2.4.3 To reduce reflections from internal lighting, etc. the bridge windows are to be inclined from the vertical plane top out, at an angle of not less than 10° and not more than 25°. Alternative arrangements will be specially considered.

2.4.4 The height of the lower edge of the front windows is to allow a forward view over the bow for a person at the navigation workstation and is not to obstruct any of the required fields of vision, see *Pt 7, Ch 9, 2.5 Fields of vision*. In this respect, the height of the lower edge of the front windows above the deck is to be kept as low as possible and, as far as practicable, is not to be more than 1000 mm above the deck surface.

2.4.5 The upper edge of the front windows is to allow a forward view of the horizon for a person with an eyeheight of 1800 mm at the conning position when the ship is pitching in heavy seas and, as far as practicable, is not to be less than 2000 mm above the deck surface.

2.4.6 Clear views through the windows in front of the conning position, navigation workstation, and, where applicable, bridge wings are to be provided at all times regardless of weather conditions. At least two windows are to provide such a view.

2.4.7 To ensure a clear view in bright sunshine, sunscreens with minimum colour distortion are to be provided. Such screens are to be readily removable and not permanently installed. Polarised and tinted windows are not to be fitted.

2.4.8 Heavy duty wipers, preferably provided with an interval function and a fresh water wash, are to be fitted.

2.4.9 Efficient cleaning, de-icing and de-misting systems are to be fitted.

2.4.10 Suitable safe external access arrangements fitted under the bridge windows are to be provided to enable cleaning in the event of failure of the above systems.

2.5 Fields of vision

2.5.1 It is to be possible to observe all objects necessary for navigation, including other traffic and navigation marks, in any direction from inside the wheelhouse. In this respect there is to be a field of view around the vessel of 360° obtained by an observer moving within the confines of the wheelhouse.

2.5.2 The view of the sea surface from the conning position and the navigation workstation is not to be obscured by more than two ship lengths, or 500 m, whichever is less, forward of the bow to 10° on either side, irrespective of the ship's draught, trim and deck cargo, see *Figure 9.2.1 View of sea surface from conning position and navigation workstation*.

2.5.3 Blind sectors caused by cargo, cargo gear and other obstructions outside the wheelhouse forward of the beam obstructing the view of the sea surface as seen from the conning position and the navigation workstation are not to exceed 10° each. The total arc of blind sectors is not to exceed 20° and the clear sector between blind sectors shall be at least 5°. However, in the view described in the preceding paragraph, each individual blind sector is not to exceed 5°.

2.5.4 The horizontal field of vision from the conning position and the navigation workstation is to extend over an arc from more than 22,5° abaft the beam on one side, through forward, to more than 22,5° abaft the beam on the other side, see *Figure 9.2.2 Horizontal field of view from conning position and navigation workstation*.

2.5.5 From the main steering position, the field of vision is to extend over an arc from dead ahead to at least 60° on each side, see *Figure 9.2.3 Field of view from main steering position*.

2.5.6 From each bridge wing, the field of vision is to extend over an arc from at least 45° on the opposite bow through dead ahead and then aft to 180° from dead ahead, see *Figure 9.2.4 Field of view from starboard bridge wing*.

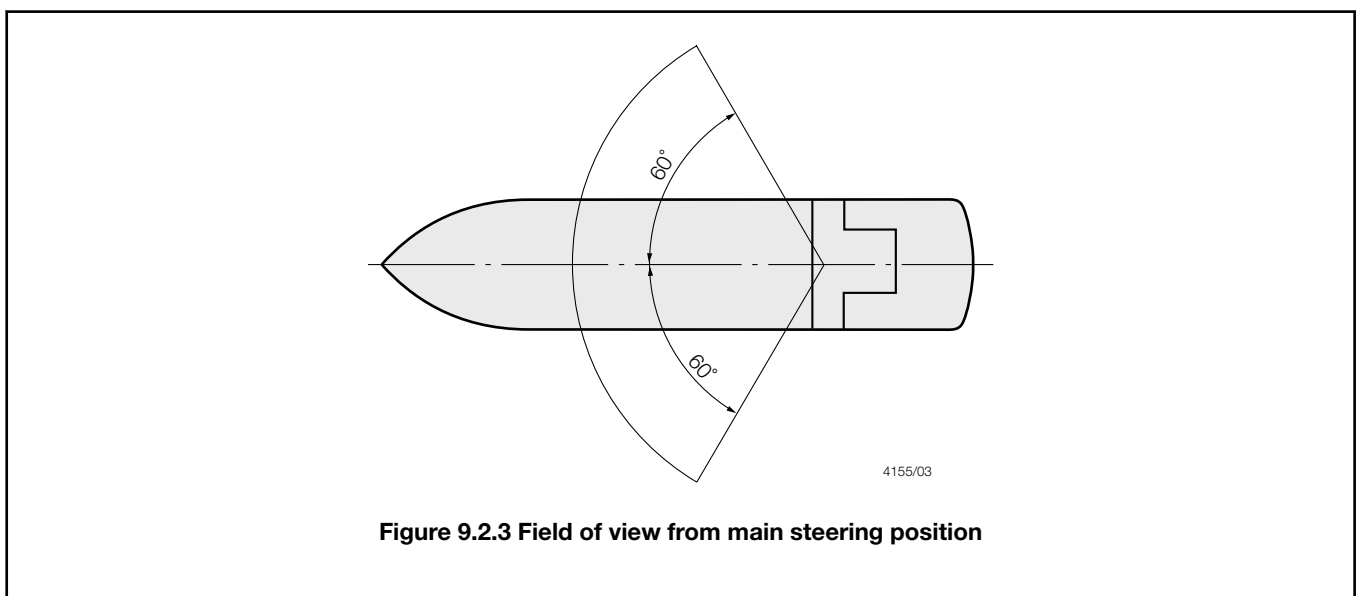
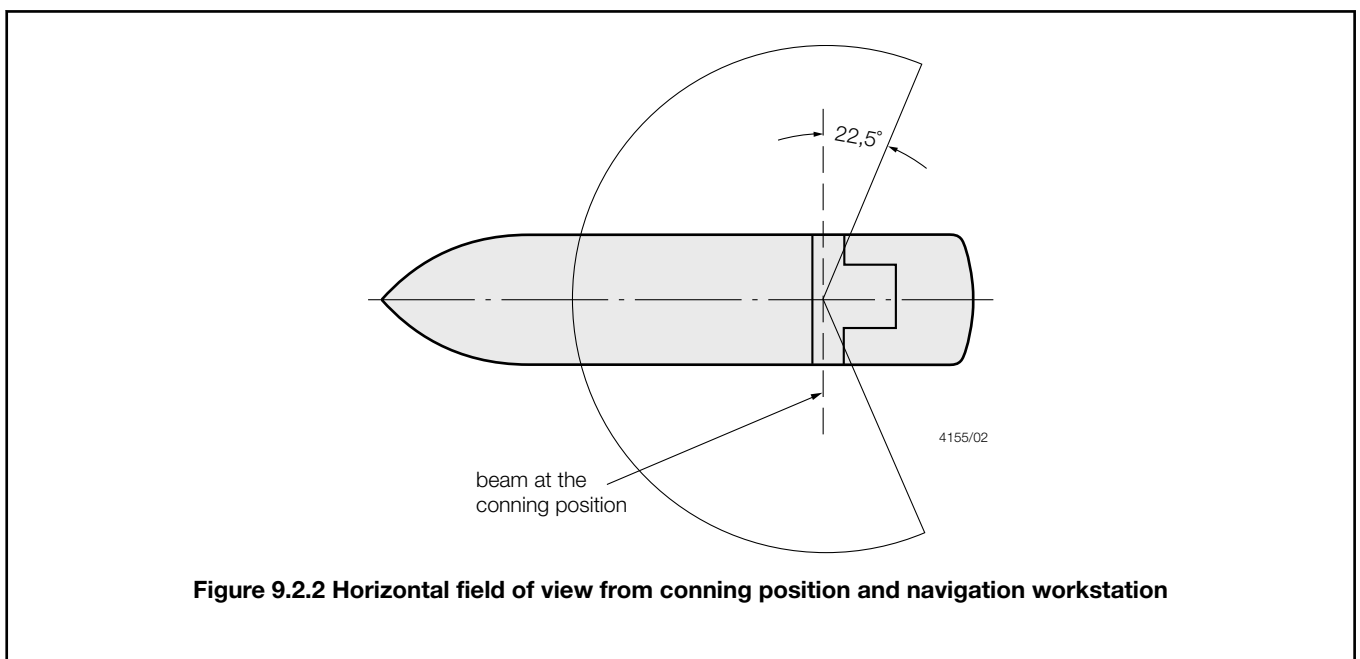
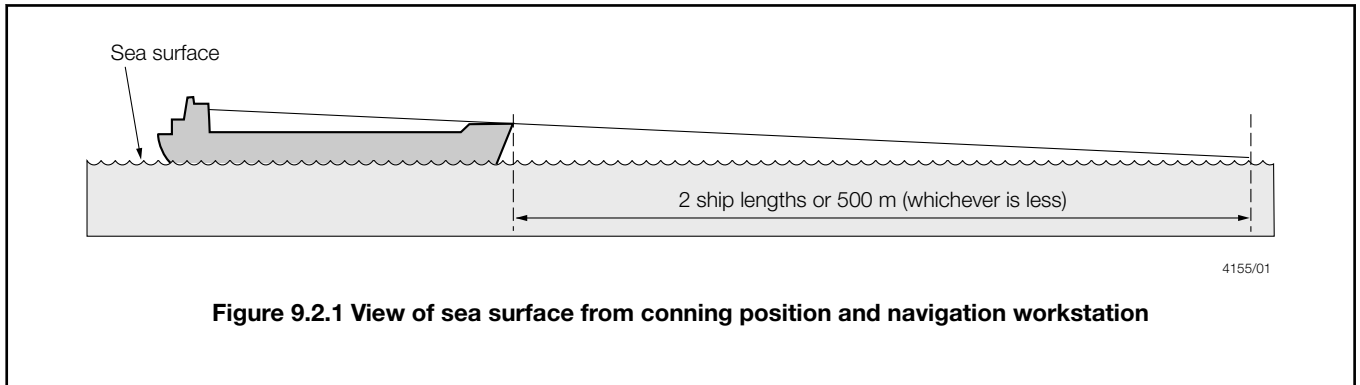

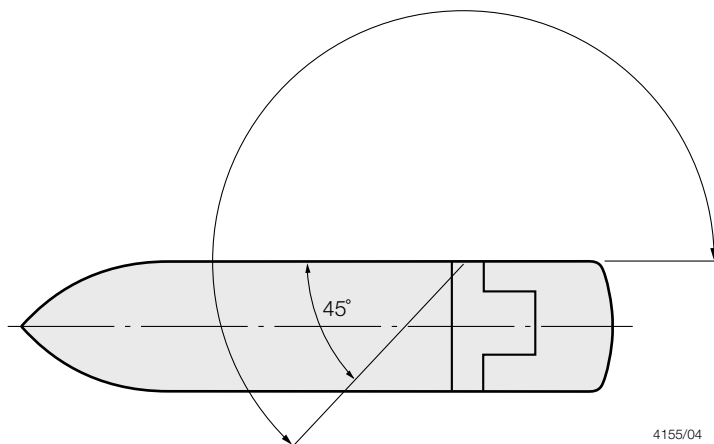

Figure 9.2.4 Field of view from starboard bridge wing

2.5.7 There is to be a line of sight from the port wing to the starboard wing through the wheelhouse.

2.5.8 The ship's side is to be visible from the bridge wing.

2.5.9 From workstations for functions other than navigation, the field of vision is to enable an effective lookout to be maintained and, in this respect, is to extend at least over an arc from 90° on the port bow, through forward, to 22,5° abaft the beam on the starboard side, see *Figure 9.2.5 Field of view from workstation other than for navigation*.

2.5.10 The height of consoles is not to interfere with the fields of vision defined above and is not to exceed 1350 mm.

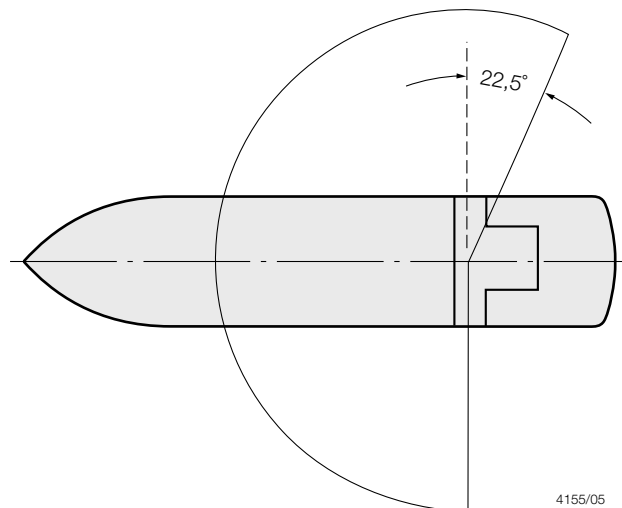

Figure 9.2.5 Field of view from workstation other than for navigation

■ Section 3

Workstations

3.1 Navigation workstation

3.1.1 A workstation for navigation is to be arranged to enable efficient operation by one person under normal operating conditions. The workstation area is to be sufficient to allow at least two operators to use the equipment simultaneously. The arrangement of instruments and controls is to allow the use of all instruments and controls necessary for navigating and manoeuvring in any normal working position.

3.1.2 An adequate conning position is to be provided close to the forward centre window. If the view in the centreline is obstructed by large masts, cranes, etc. two additional conning positions giving a clear view ahead are to be provided, one on the port side and one on the starboard side of the centreline, no more than 5 m apart. In addition to the conning position, a second position with a view of the area immediately in front of the bridge superstructure is to be provided close to a forward window or, alternatively, the conning position is to be wide enough to accommodate two persons.

3.1.3 The main steering position is to be located on the ship's centreline, unless the view ahead is obstructed by large masts, cranes, etc. In this case, the steering position is to be located a distance to starboard of the centreline sufficient to obtain a clear view ahead and special steering references for use by day and night are to be provided, e.g. sighting marks forward.

3.1.4 The following facilities are to be provided at the navigation workstation:

- Radar and radar plotting facilities, see *Pt 7, Ch 9, 3.1 Navigation workstation 3.1.5*.
- Position-fixing system displays, see *Pt 7, Ch 9, 3.1 Navigation workstation 3.1.6*.
- Echo sounder display.
- Speed and distance indications, see *Pt 7, Ch 9, 3.1 Navigation workstation 3.1.11* and *Pt 7, Ch 9, 3.1 Navigation workstation 3.1.12*.
- Gyrocompass display, see *Pt 7, Ch 9, 3.1 Navigation workstation 3.1.7*.
- Magnetic compass display.
- Wind speed and direction indication.
- Steering controls and indication, see *Pt 5, Ch 19, 5 Electric power circuits, electric control circuits, monitoring and alarms*.
- Rate of turn indication.
- Course/track controls and indications, see *Pt 7, Ch 9, 3.1 Navigation workstation 3.1.8*.
- Main propulsion and thruster controls and indication, see *Pt 6, Ch 1, 2.6 Bridge control for main propulsion machinery* and *Pt 5, Ch 7, 5.3 Controllable pitch propellers and transverse thrust units*.
- Watch safety system acknowledge.
- Watch safety system manual initiation.
- Internal communications system.
- VHF radiotelephone.
- Time indication.
- Window clear view controls.
- Navigation lights controls.
- Whistle control.
- Morse light keys.
- Wheelhouse/equipment lighting controls.
- Automatic ship identification system (AIS) information.
- Sound reception system where fitted, see *Pt 7, Ch 9, 2.2 Environment 2.2.8*.
- Means to cease the distribution of long-range identification and tracking information, where required by SOLAS Ch V, *Regulation 19 - Carriage requirements for shipborne navigational systems and equipment*.

3.1.5 Two functionally independent radars or alternative means are to be provided to determine and display the range and bearing of radar transponders and other surface craft, obstructions, buoys, shorelines and navigational marks. One of the radars is to operate in the X-band (9 GHz) and the other is to operate in the S-band (3 GHz).

3.1.6 At least two different automatic position-fixing systems giving a continuous display of latitude and longitude are to be provided in the interests of redundancy and diversity. One of these is to be GPS or equivalent. The other is to be a system

providing similar global coverage such as GLONASS, where available. When a second GPS receiver is installed to satisfy this requirement, at least one of the receivers is to be provided with differential correction functionality (DGPS) and the receivers are to be arranged to operate independently as far as is practicable.

3.1.7 A gyrocompass or alternative means for determining, displaying and transmitting the ship's heading by shipborne, non-magnetic means, is to be provided and is to be clearly readable by the helmsman at the main steering position. The heading information is to be used directly by the radars, radar plotting aids and automatic identification system, see *Pt 7, Ch 9, 3.1 Navigation workstation 3.1.5* and *Pt 7, Ch 9, 3.1 Navigation workstation 3.1.13*. The gyrocompass is to be provided with a gyrocompass heading repeater located at the emergency steering position in the steering gear compartment and a gyrocompass bearing repeater allowing bearings to be taken over 360°.

3.1.8 An autopilot, track control system or alternative means of automatically maintaining the ship's heading or a straight track is to be provided. At any time, it is to be possible to immediately restore manual control.

3.1.9 Heading monitoring is to be provided to monitor the actual heading information by independent heading sources. An off-course warning is to be given if the actual heading of the ship deviates from the set track course beyond a pre-set value. The pre-set off-course warning limit is to be large enough to prevent unnecessary alarms.

3.1.10 Where automatic track following is provided, sufficient warning is to be given of the approach of a waypoint, so that, in the event of no acknowledgment from the officer of the watch, there is adequate time for the backup navigator to reach the bridge and accept the change of course.

3.1.11 A speed log or alternative means of indicating the ship's speed and distance through water is to be provided. The speed through water measurement is to be used directly by the ARPA as an aid to collision avoidance.

3.1.12 A speed log or alternative means of indicating the ship's speed and distance over ground is to be provided, which is to be separate from the device required by *Pt 7, Ch 9, 3.1 Navigation workstation 3.1.11*. Speed over ground is to be indicated in both the fore-aft and athwartships directions.

3.1.13 Navigational systems and equipment are to be of a type approved by the national administration and in conformity with appropriate performance standards not inferior to those adopted by IMO from time to time. Documentary evidence to this effect is to be submitted. See SOLAS 1974 as amended, Ch V, *Regulation 18 - Approval, surveys and performance standards of navigational systems and equipment and voyage data recorder*.

3.1.14 Where alternative means of fulfilling the navigational requirements are permitted, the means are to be approved by the national administration and in conformity with appropriate performance standards.

3.2 Voyage planning workstation

3.2.1 A voyage planning workstation is to be provided at which the following facilities are available:

- Chart display and information facilities.
- Position-fixing systems.
- Time indication.

3.2.2 Time indication at the voyage planning workstation is to be derived from the same system as used at the navigation workstation.

3.2.3 An Electronic Chart Display and Information System (ECDIS) is to be provided. Chart tables for paper charts, where provided, are to be large enough to accommodate all chart sizes normally used internationally for maritime traffic and are to have facilities for illuminating the chart, see also *Pt 7, Ch 9, 2.3 Lighting 2.3.8*.

■ Section 4 Systems

4.1 Alarm and warning systems

4.1.1 Alarms associated with navigation equipment are to be both audible and visual and are to be centralised for efficient identification. Repeater displays may be fitted on the bridge wings and at other appropriate positions on the bridge where necessary.

4.1.2 The following alarms are to be provided:

- Closest point of approach.
- Shallow depth.
- Waypoint approaching (where automatic track following is provided).
- Off-course.
- Off-track (where automatic track following is provided).
- Steering alarms, see *Table 19.5.1 Alarm requirements in Pt 5, Ch 19 Steering Arrangements* or *Table 20.4.1 Alarms for control systems in Pt 5, Ch 20 Azimuth Thrusters*, as applicable.
- Navigation light failure alarms, see *Pt 6, Ch 2, 15.6 Navigation lights*, including *Pt 6, Ch 2, 15.6 Navigation lights 15.6.8* for grouping.
- Gyrocompass failure.
- Watch safety system failure.
- Failure of any power supply to the distribution panels referred to in *Pt 7, Ch 9, 4.4 Power supplies 4.4.1*.

4.1.3 Audible signals are to be designed not to startle operators. Suitable types are shown in *Table 9.4.1 Suitable audible signals*.

Table 9.4.1 Suitable audible signals

Type	Typical characteristics	Considerations
Buzzer	Low intensity and frequencies	Good alerting in quiet environment without startling
Bell	Moderate intensity and frequencies	Penetrates low frequency noise well, abrupt onset has a high alert value
Chime	Moderate intensity and frequencies	Good in quiet environment, non-startling
Tone	Moderate intensity and limited frequency range	Convenient for intercom transmission, high alert value if intermittent

4.1.4 In the event that any alarm initiated by navigation equipment on the navigating bridge has not been acknowledged on the bridge within a period of 30 seconds, a visual and audible alarm is to be initiated immediately to warn the appointed back-up navigator and/or the Master.

4.1.5 In the event that the alarm required by *Pt 7, Ch 9, 4.1 Alarm and warning systems 4.1.4* is not acknowledged, the system is to initiate an alarm at the locations of further crew members capable of taking corrective actions following a time delay sufficient to allow the Master or back-up navigator to reach the bridge. The time interval is to be adjustable between 90 seconds up to a maximum of 3 minutes. In ships, other than passenger ships, the alarm to warn the further crew members may be initiated at the same time as the alarm to warn the Master and back-up navigator.

4.1.6 The functionality specified in *Pt 7, Ch 9, 4.1 Alarm and warning systems 4.1.4* and *Pt 7, Ch 9, 4.1 Alarm and warning systems 4.1.5* may be incorporated in the watch safety system required by *Pt 7, Ch 9, 4.2 Watch safety system*, or in another fixed system.

4.2 Watch safety system

4.2.1 A watch safety system satisfying the requirements of the IMO *Resolution MSC.128(75) - Performance Standards for a Bridge Navigational Watch Alarm System (BNWAS) - (adopted on 20 May 2002)* and approved by the national administration is to be provided to monitor the well-being and awareness of the watchkeeper.

4.2.2 If, depending upon the shipboard work organisation, the backup navigator may attend locations not connected to the alarm transfer system, a wireless portable device is to be provided enabling both the transfer of alarms and two-way speech communication with the bridge. An audible warning from the portable device is to be provided in the event of loss of the wireless link with the bridge. Alternative arrangements will be considered.

4.2.3 Acknowledgement of any alarm is to automatically reset the time interval between warnings. Manual adjustment of controls may also be used for this purpose. Manual adjustment of controls and navigation equipment (see also *Pt 7, Ch 9, 5.3*

Equipment 5.3.14) is to automatically reset the watch safety interval timer. Reset arrangements based on the detection of movement in the bridge are not considered to satisfy this requirement or to confirm well-being and watch-keeping awareness.

4.3 Communications

4.3.1 A telephone system is to be provided to enable two-way speech communication between the wheelhouse and at least the following locations:

- machinery control station space, see *Pt 6, Ch 1, 2.6 Bridge control for main propulsion machinery 2.6.7*;
- emergency steering position in the steering gear compartment;
- Master's and Navigating Officers' cabins, offices, mess and public rooms.

4.3.2 The bridge is to have priority over the system.

4.3.3 A list of extension numbers is to be clearly displayed adjacent to each telephone.

4.4 Power supplies

4.4.1 Local distribution panels are to be provided for all items of electrically operated navigational equipment, the telephone system, the watch safety system and the clear view systems. These panels are to be supplied by two exclusive circuits, one fed from the main source of electrical power and one fed from an emergency source of electrical power. Each item of equipment is to be individually connected to its distribution panel. The power supplies to the distribution panels are to be arranged with automatic changeover facilities between the two sources, see also *Pt 6, Ch 2, 15.7 Navigational aids*. Failure of any power supply to the distribution panels is to initiate an audible and visual alarm. This alarm should be included in the ship's alarm system, as required by *Pt 6, Ch 1, 4.2 Alarm system for machinery*, where applicable.

4.4.2 The watch safety system and the telephone system are to remain operational during blackout conditions.

4.4.3 Following a loss of power which has lasted for 45 seconds or less, all navigation functions are to be readily re-instated. In this respect, all navigational equipment is to recover within five minutes, with minimum operator intervention, by virtue of the emergency source and, where necessary, an uninterruptible power source.

Section 5

Integrated Bridge Navigation System – IBS notation

5.1 General

5.1.1 Where it is proposed that the bridge navigation functions are so arranged as to form an integrated bridge system, the requirements of *Pt 7, Ch 9, 5.2 General requirements* are to be complied with.

5.2 General requirements

5.2.1 For assignment of the notation **IBS**, in addition to satisfying the other requirements of this Section:

- (a) the layout of the bridge and the equipment located on the bridge is to satisfy the requirements of a relevant international or national ergonomic or human-centred design Standard or an acceptable equivalent; or
- (b) the notation **NAV1** is also to be assigned and the layout of the bridge and the equipment on the bridge are to satisfy the requirements *Pt 7, Ch 9, 1 General requirements to Pt 7, Ch 9, 4 Systems*; or
- (c) where the bridge is not intended to operate a periodic one man watch, the layout of the bridge and the equipment on the bridge are to satisfy the requirements of *Pt 7, Ch 9, 1 General requirements to Pt 7, Ch 9, 4 Systems*, with the exception that the requirements of *Pt 7, Ch 9, 4.3 Communications* may be relaxed.

5.2.2 Where *Pt 7, Ch 9, 5.2 General requirements 5.2.1* is applicable, the submissions required by *Pt 7, Ch 9, 1.2 Information and plans required to be submitted 1.2.1* are to include evidence demonstrating satisfaction of the requirements of an identified relevant Standard.

5.2.3 To satisfy *Pt 7, Ch 9, 5.2 General requirements 5.2.2*, the evidence submitted is to:

- (a) be submitted to LR for assessment, including identification of testing necessary to verify compliance in the submitted test schedules; or

(b) include relevant statutory documentation demonstrating compliance with the relevant identified standard to the satisfaction of the National Administration. Such documentation is to be submitted prior to the assignment of the **IBS** notation. This may necessitate co-ordination of classification and statutory Surveys, particularly for new construction, before the **IBS** notation may be assigned.

5.2.4 Where *Pt 7, Ch 9, 5.2 General requirements 5.2.1* is applicable, the submissions required by *Pt 7, Ch 9, 1.2 Information and plans required to be submitted 1.2.1* are to include plans and information for the consideration of LR which demonstrate that the applicable requirements of *Pt 7, Ch 9, 1 General requirements to Pt 7, Ch 9, 4 Systems* have been satisfied.

5.2.5 The design features for computer hardware, local area networks and software required by *Pt 6, Ch 1, 2.10 Programmable electronic systems - General requirements, Pt 6, Ch 1, 2.11 Data communication links, Pt 6, Ch 1, 2.13 Programmable electronic systems - Additional requirements for essential services and safety critical systems* and *Pt 6, Ch 1, 2.14 Programmable electronic systems - Additional requirements for integrated systems* respectively are to be complied with. Alarms and warnings associated with hardware and data communication are to be incorporated in the centralised alarm system required by *Pt 7, Ch 9, 4.1 Alarm and warning systems*.

5.2.6 Failure of a part of the integrated bridge navigation system is not to affect other parts except for those that directly depend upon the information from the defective part. Following such a failure, it is to be possible to operate each other part of the system separately.

5.3 Equipment

5.3.1 Two independent gyrocompasses are to be available to provide heading information to the system. The heading signal from each gyrocompass is to be continuously available for display and for providing input to all relevant items of navigational equipment.

5.3.2 Only one gyrocompass is to be used by the integrated bridge system at any time for main display and control purposes. The navigating officer is to be able to switch between compasses at any time. The non-selected compass is to be automatically used as the independent heading source for the off-course warning required by *Pt 7, Ch 9, 3.1 Navigation workstation 3.1.9*.

5.3.3 It is to be possible to compare readings from each gyrocompass via the navigation workstation displays.

5.3.4 Automatic comparison between the gyrocompasses is to be provided and an alarm given if the difference between heading signals exceeds a pre-set value.

5.3.5 The capability to receive and utilise differential GPS corrections (or an equivalent) is to be included in the integrated bridge system.

5.3.6 As a minimum, the following information is to be displayed at the navigation workstation via visual display units:

- Steering mode.
- Gyro heading.
- Course to steer.
- Rate of turn.
- Rate of turn order.
- Speed and distance (from log and from GPS).
- Speed order.
- Waypoint bearing, distance and ETA.
- Water depth and alarm setpoint.
- Position fix from each available system.
- Main propulsion and thruster indication, see *Pt 6, Ch 1, 2.6 Bridge control for main propulsion machinery* and *Pt 5, Ch 7, 5.3 Controllable pitch propellers and transverse thrust units*.
- Steering indication, see *Pt 5, Ch 19, 5 Electric power circuits, electric control circuits, monitoring and alarms*.
- Wind speed and direction.
- Time, see *Pt 7, Ch 9, 3.2 Voyage planning workstation 3.2.2*.

5.3.7 Additional information such as machinery monitoring, fire detection, cargo control, etc. may also be provided via additional pages on the visual display units.

5.3.8 The centralised alarm system and the watch safety system required by *Pt 7, Ch 9, 4.1 Alarm and warning systems* and *Pt 7, Ch 9, 4.2 Watch safety system* respectively are to be incorporated as functions of the integrated bridge system and are to be presented to the navigating officer via the conning display. The presentation and display of alarms and warnings is not to mask,

obscure or degrade essential information displayed to aid navigational functions and maintain awareness of the navigational information, *see also Pt 7, Ch 9, 5.5 Alarm management.*

5.3.9 A route planning capability is to be provided by the integrated bridge system. This is to allow a voyage to be pre-planned as a series of waypoints and turn radii. It is to be possible to edit a voyage plan at any time without affecting route control and monitoring.

5.3.10 An automatic track following capability is to be provided in conjunction with the pre-planned route. The position fix used by the system is to be based at least upon GPS or equivalent, and is to be cross-checked by dead-reckoning, based upon speed over ground provided by the ship's log. In areas where differential corrections are available, it is to be possible to utilise these in the track following system.

5.3.11 In the event of failure of the track following capability the current heading or rate of turn is to be maintained until manually altered by the navigating officer. The quality of position fix input to the system is to be monitored, *see also Pt 7, Ch 9, 3.1 Navigation workstation 3.1.10 and Pt 7, Ch 9, 4.1 Alarm and warning systems 4.1.2.*

5.3.12 The integrated bridge system is to incorporate a display, which combines simultaneously the ECDIS high resolution colour representation of a nautical chart with a continuously updated record of own ship's position, pre-planned track, and radar targets in the vicinity. The entire tactical situation is to be displayed for the navigating officer in such a way that any risk from approaching, overtaking or crossing vessels may be assessed. Factors affecting the vessel's freedom to manoeuvre, such as water depths, channel boundaries, separation zones and other traffic are to be shown on the display.

5.3.13 The following alarms are to be provided and included in the centralised alarm system specified by *Pt 7, Ch 9, 4.1 Alarm and warning systems 4.1.1*:

- Off-track
- Waypoint approaching, *see Pt 7, Ch 9, 3.1 Navigation workstation 3.1.10.*
- Position fix inaccurate/lost.
- Loss of heading input.
- Loss of log input.
- Equipment or sub-system failure.
- Gyro mis-match.

5.3.14 Manual adjustment of any of the facilities of the integrated bridge system is to reset automatically the watch safety interval timer.

5.4 Operator interface

5.4.1 Integrated display and control functions are to adopt a consistent man-machine interface philosophy and strategy. Particular consideration is to be paid to symbols, colours, controls, and information priorities.

5.4.2 The size, colour and density of text and graphic information displayed on a visual display unit is to be such that it may be read easily from the normal operator position under all operational lighting conditions.

5.4.3 Means are to be provided for the manual adjustment of the brightness of each visual display unit.

5.4.4 All information is to be presented on a background of high contrast, emitting as little light as possible by night.

5.4.5 Paged displays are to be presented in a way which allows the operator to find quickly the information needed. An overview page is to be easily available to remind the operator of the paging system.

5.4.6 Pages are to have a standardised format. Particular types of information and functional areas should be presented in a consistent manner, e.g. in the same position on different pages.

5.4.7 Each page is to have a unique identifying label on the screen.

5.4.8 Keyboards are to be divided logically into areas enabling rapid access to a desired function. Alphanumeric, paging and specific system keys are to be grouped separately and grouping is to be identical at all operator interfaces.

5.4.9 Soft keys may be used for display control and operation of systems non-critical to the safe operation of the vessel, otherwise dedicated controls are to be used.

5.4.10 Functions requested by the operator are to be acknowledged and confirmed by the system on completion.

5.4.11 Interfaces are to incorporate the capability for operators readily to decline or override automatic ship control functions critical to safe operation. See *Pt 6, Ch 1, 1.2 Documentation required for design review 1.2.2* regarding submission of information on safety functions and overrides.

5.4.12 Default values, where applicable, are to be indicated by the system when requesting operator input.

5.4.13 If an input error is detected by the system, it is to allow the operator to correct the error immediately.

5.4.14 The system is to require confirmation from the operator for critical actions, e.g. they should not rely on single keystrokes.

5.4.15 Input error messages are to guide the correct responses, e.g.:

use Invalid entry: re-enter set point between 0 and 10

not Invalid entry.

5.4.16 All functions of the integrated bridge system are to remain available in the event of a single failure of an operator interface. This is to be achieved through redundancy in the integrated bridge system interfaces.

5.5 Alarm management

5.5.1 All alarms provided on the bridge are to be included in the centralised alarm system required by *Pt 7, Ch 9, 4.1 Alarm and warning systems 4.1.1*.

5.5.2 In general, the alarm system is to be in accordance with *Pt 6, Ch 1, 2.3 Alarm systems, general requirements, A.1021(26) Code on Alerts and Indicators, 2009 and MSC.302(87) Performance Standards for Bridge Alert Management*.

5.5.3 Alarm management on priority and functional levels is to be provided within the integrated bridge system. Alarms and other alerts are to be prioritised according to the urgency and type of response required by the bridge team, as follows:

- (a) **Emergency alarms** – alarms which indicate that immediate danger to human life, or to the ship and its machinery exists, and that immediate action must be taken.
- (b) **Alarms** – conditions requiring immediate attention and action by the bridge team:
 - to avoid any kind of hazardous situation and to maintain the safe operation of the ship, including escalation of unacknowledged warnings; or
 - alerts which indicate that a caller is in distress or has an urgent message to transmit.
- (c) **Warnings** – conditions or situations which require immediate attention for precautionary reasons, to make the bridge team aware of conditions which are not immediately hazardous, but may become so.
- (d) **Cautions** – awareness of a condition which still requires attention out of the ordinary consideration of the situation or of given information.

5.5.4 Appropriate alarm management is to be provided. This includes prioritisation, distribution and recording of alarms and other alerts as required.

5.5.5 Within each priority, alerts are to be arranged in groups in order to reduce the quantity of information presented to the operator. More detailed information on the group alarm is to be readily available from the integrated bridge system on request.

5.5.6 Group alarms may be arranged on the bridge to indicate machinery faults, but alarms associated with faults requiring speed or power reduction or the automatic shutdown of propulsion machinery are to be identified by separate group alarms or by individual alarm parameters.

5.5.7 The following alarms are not to be grouped:

- Emergency alarms.
- Separate group alarms associated with faults requiring speed or power reduction or the automatic shutdown of propulsion machinery.
- Steering gear alarms.
- Navigation light power supply failure alarms, see *Pt 6, Ch 2, 15.6 Navigation lights 15.6.8*.

5.5.8 Alerts are to be displayed in order of priority. Within the priorities, alerts are to be displayed in the order in which they occur. The visual display units are to provide immediate display of new information, regardless of the information display page currently selected. This may be achieved by provision of a dedicated alert monitor, a dedicated area of screen for alerts or other suitable means.

5.5.9 Unacknowledged alarms are to be distinguished by either flashing text or a flashing marker adjacent to the text, and not merely by a change of colour. Acknowledged alarms are to be distinguished by either steady illuminated text or a steady illuminated marker adjacent to the text.

5.5.10 The centralised alarm system is to be capable of displaying at least 20 items simultaneously. There is to be a clear and unambiguous indication that there are additional items requiring attention when the display does not show all active alerts simultaneously, and it is to be possible to display the additional messages and to return to the display containing the highest priority items by single operator actions.

5.5.11 Alerts are to be acknowledged individually. It is to be possible temporarily to silence all audible signals with a single operator action.

5.5.12 The characteristics of audible warning and, where provided, caution signals are to be such that it is possible to differentiate these from audible alarm signals.

5.6 Power supplies

5.6.1 All equipment forming part of the integrated bridge navigation system is to be regarded as navigational equipment and, as such, is to have power supplies in accordance with *Pt 7, Ch 9, 4.4 Power supplies*.

■ Section 6 Trials

6.1 General

6.1.1 Before a new installation (or any alteration or addition to an existing installation) is put into service, tests are to be carried out to ensure satisfactory operation of the navigational equipment. These tests are in addition to any acceptance tests which may have been carried out at the manufacturers' works and are based on the approved test schedule as required by *Pt 7, Ch 9, 1.2 Information and plans required to be submitted 1.2.1*.

6.1.2 For **IBS** Notation, testing at the manufacturer's works and trials on board are to be carried out that cover the individual components and their interaction; and the bridge functions and their integration to form the Integrated Bridge System.

6.1.3 Two copies of the test schedule, signed by the Surveyor and Builder, are to be provided on completion of the survey. One copy is to be placed on board the ship and the other submitted to LR.

6.1.4 Acceptance tests and trials for Programmable Electronic Systems are to include verification of software lifecycle activities appropriate to the stage in the system's lifecycle at the time of system examination.

Section

- 1 **General requirements**
- 2 **Plans and documentation**
- 3 **Ventilation and hold temperature**
- 4 **Electrical, including container plug-in sockets**
- 5 **Instrumentation, control and alarm systems**
- 6 **Hold access and maintenance access arrangements**
- 7 **Water cooler refrigeration units**
- 8 **Deck-stowed refrigerated containers**
- 9 **Inspection and testing on completion**
- 10 **Spare gear**

■ Section 1 General requirements

1.1 General

1.1.1 The requirements of this Chapter apply to ships where the class notation **CRC** 'carriage of refrigerated containers' is requested.

1.1.2 This notation may be applied to any ship which has the ability to carry refrigerated containers. The requirements of this Chapter cover refrigerated containers stowed on deck as well as in a hold space. A descriptive notation may be assigned in addition to the **CRC** notation giving details of electrical power and type of cargo.

1.1.3 The requirements are additional to the classification requirements for ships contained in other applicable parts of the Rules.

1.1.4 Ships which comply with the requirements of this Chapter will be eligible for the applicable class notation specified in *Pt 1, Ch 2, 2.6 Class notations (refrigerated cargo installations (RMC), controlled atmosphere (CA) systems and carriage of refrigerated containers (CRC))*.

1.1.5 An example of a typical class notation for a container ship classed with LR, fitted with a ventilation system built under Special Survey and fitted with electrical plug-in points for deck stowed refrigerated containers, would be:

- (a) **+ CRC 230/140** to maintain 230 hold-stowed and 140 deck-stowed refrigerated containers operating at their design condition with a 24 hour average external ambient air temperature of 35°C.

1.1.6 An example of a typical class notation for a reefer ship classed with LR, fitted with electrical plug-in points for deck stowed refrigerated containers, would be:

- (a) **+ CRC -/110** to maintain 110 deck-stowed refrigerated containers operating at their design condition with a 24 hour average external ambient air temperature of 35°C.

1.1.7 In addition to any class notation, an appropriate descriptive notation may be assigned to provide additional information about the ship's ability to carry refrigerated containers.

1.1.8 An example of a typical descriptive notation, which may be assigned in addition to the class notation, would be:

- (a) **crc 2,800 kW** provided with a power generating capacity of 2,800 kW dedicated to supplying the container plug-in points.
 (b) **crc 60%/40%** stowage ratio of 60% deep frozen and 40% chilled cargoes

1.1.9 These Rules do not cover any requirements for alarm and monitoring systems that may be fitted to container refrigeration units.

1.2 Novel arrangement and designs

1.2.1 Where the proposed ventilation arrangement is novel in design, or the ventilation system involves the use of an arrangement different from that specified in the following sections, special tests may be required and a suitable descriptive note may be assigned.

1.2.2 The carriage of refrigerated containers in the hold spaces of ships other than dedicated container ships will be given special consideration. The **CRC** and descriptive notations will be assigned provided that the ventilation system is approved, installed and tested in accordance with the requirements of this Chapter.

1.2.3 Where a dedicated fresh water circulation system is installed to supply cooling water to containers fitted with an optional water cooled condenser, the fresh water system will also need to comply with the relevant Sections of *Pt 5, Ch 12 Piping Design Requirements* of the Rules.

1.3 Definitions

1.3.1 **Balanced ventilation system** means a ventilation system consisting of a combination of forced draught and induced or natural draught, to produce a pressure condition in the hold space approximately equal to atmospheric pressure.

1.3.2 **Blackout** means that the main and auxiliary machinery installations, including the main power supply, are out of operation but the services for bringing them into operation (e.g. compressed air, starting current from batteries etc.) are available.

1.3.3 **Container cell** means the position of an individual container. This is usually within a set of vertical cell guides and is normally enclosed by transverse stringers located above and below the container.

1.3.4 **Container electrical power supply** means the generated power supply which is dedicated to supplying the total number of refrigerated containers and the hold ventilation system fan motors.

1.3.5 **Container plug-in point** means an electrical socket located at each applicable container location on deck and each cell location below deck being in accordance with Annex L of ISO 1496-2 : 1996.

1.3.6 **Design conditions** means the lowest design internal container temperature and the design maximum hold space temperature.

1.3.7 **Hold space** means an enclosed space containing refrigerated containers. The containers are usually restrained within cell guides. For hatch coverless ships, hold space means the space below the hatch coamings.

1.3.8 **Independent ventilation system** means a ventilation system that is in no way connected to another ventilation system and there is no provision available to allow connection to another ventilation system.

1.3.9 **Refrigerated container** means a standard container with a self-contained refrigeration system, located within the outer dimensions of the container, which can be driven by electrical power fed from an external power supply. The refrigeration system may be either a 'clip-on' or an integral type of cooling unit.

1.3.10 **Stack factor** means the ratio of the actual heat flowing into the containers forming the stack, to the heat which would flow into the same containers if all their surfaces were completely exposed to the hold temperature.

1.3.11 **Standard container** means a forty-foot equivalent unit (FEU) standard production container constructed in compliance with LR's Container Certification Scheme, or another recognised *Container Certification Scheme* in accordance with ISO 1492/2 requirements. The container may be of the normal or 'high-cube' type.

1.3.12 **Stowage ratio** means the proportion of deepfrozen cargo in relation to banana or chilled cargoes. Unless specifically stated, the stowage ratio will be deemed to be 50 per cent deep-frozen and 50 per cent chilled cargo.

1.3.13 **Ventilation system** means a forced ventilation arrangement using mechanical fans to supply and/or extract air from the hold space.

■ Section 2 Plans and documentation

2.1 General

2.1.1 The following plans and information regarding the hold ventilation systems and the electrical supplies to container plug-in points are to be submitted in triplicate for appraisal before construction is commenced:

(a) **Plans of ventilation arrangements:**

- Location and installation details of each hold space ventilation system showing duct arrangement and sizes.
- Details of all mechanical ventilation fans including locations, number, duty at design conditions and power consumption.
- Details of air inlets including number, type, size and locations.
- Details of air outlets including number, type, size and locations.
- Details and locations of dampers and flaps, if applicable.

(b) **Plans of hold spaces:**

- Refrigerated container stowage plans, including sectional elevation and plan views.
- Design pressure or vacuum in each hold space.
- Details of hatch cover sealing arrangements.
- Personnel access arrangements.
- Details and locations of hold temperature measurement sensors.
- Details of any pressure/vacuum safety valves if applicable.

(c) **Ventilation throughput:**

- Specified air throughput rate and proposed method of measurement.
- Design temperature rise in the hold space and corresponding diurnal external ambient air temperature and relative humidity.
- Schematic arrangement of the ventilation system showing proposed air volume and velocity at junctions.

(d) **Plans of deck-stowed containers:**

- Refrigerated container stowage plans, including sectional elevation and plan views.
- Details of access arrangements for maintenance and monitoring of refrigeration units fitted to deck-stowed containers.

(e) **Hull structure:**

- Details of associated openings through the hull structure are to be submitted.

(f) **Electrical.** In addition to the applicable requirements of *Pt 6, Ch 2, 1.2 Documentation required for design review*, the following information and plans specific to the container plug-in points and ventilation system are to be submitted:

- Power supply arrangements to the deck stowed refrigerated containers.
- Power supply arrangements to the hold space stowed refrigerated containers.
- Power supply arrangements to the ventilation system.
- Single-line diagram of the ventilation system. This is to include rating of motors, insulation type, size and current loading of cables and make, type and rating of protective devices.
- A schedule of normal operating loads of the ventilation system estimated for the design conditions expected.

(g) **Control equipment.** In addition to the applicable requirements of *Pt 6, Ch 1, 1.2 Documentation required for design review*, the following information and plans specific to the ventilation system are to be submitted:

- Line diagram of control circuits.
- List of monitored, control and alarm points.
- Locations of control panels and consoles.
- Details of alarm system, including location of control panel and audible and visual warning devices.

(h) **Testing:**

- Details of the testing and commissioning programme, including instrumentation to be used, are to be submitted.

■ Section 3**Ventilation and hold temperature****3.1 Ventilation system**

3.1.1 Means are to be provided to maintain the hold space at an acceptable temperature. This can be achieved by either; the direct removal of the waste heat from the refrigerant equipment of each container, or by the dissipation of the waste heat using large quantities of external ambient air. In each case the system is to be arranged in such a way as to minimise its affect on the hold space temperature. This may be accomplished by the use of a ventilation system of a mechanical supply and/or extract type.

3.1.2 The selection of a maximum allowable hold temperature is to be agreed between the designer and Operator/Owner. Whilst the recommendations given in these Rules do not stipulate a maximum allowable hold temperature, generally it should not exceed 45°C dry bulb. Guidance should be sought from container manufacturers on the maximum allowable ambient air temperature. When determining the maximum allowable hold temperature, the maximum number of refrigerated containers within the hold space, operating at their design condition, is to be taken into consideration.

3.1.3 The ventilation system is to have sufficient capacity to remove or dissipate the heat from each designated refrigerated container cell and maintain the hold temperature at or below the maximum allowable hold temperature.

3.1.4 The volume of air to be supplied or exhausted from a hold space per refrigerated container is at the discretion of the ventilation system designer. For guidance purposes, an indication of the amount of air required for a standard FEU having an air cooled condenser operating at the example notation as stated in *Pt 7, Ch 10, 1.1 General 1.1.5* is as follows:

Simple supply only system 90 m³/min

Supply and exhaust duct system 75 m³/min

Sealed exhaust system 37 m³/min

3.1.5 The design of the hold space is to be compatible with the type of ventilation system proposed. For example, for supply and ducted exhaust systems, the semi enclosure of each stringer level may be beneficial. For a simple supply only system the provision of multiple gratings in each stringer level would benefit the free circulation and removal of warm air.

3.1.6 Only container cells served by the ventilation system are to be used for the transportation of refrigerated containers.

3.1.7 The design heat rejection for each container cell and the total hold space heat rejection, including any heat imparted from the ventilation system fans, if applicable, are to be stated. Guidance on heat rejection values which may be used is given below.

3.1.8 The minimum quantity of air supplied or extracted for each container cell and for each hold space is dependent on the type of system proposed and to be stated.

3.1.9 The ventilation system designer is to stipulate the maximum allowable back pressure occurring within the hold space. Due regard needs to be given to this value when selecting the ventilation fans and their ability to operate efficiently again the proposed maximum back pressure. The lower the back pressure, the more efficient the system and, hence, the lower the electrical power requirement to drive the fan motors for a given air throughput.

3.1.10 For supply air systems, the air outlet at each container location is to be such as to provide a flow of air towards the container's integral refrigeration system. Consideration should be given to the use of movable spigot outlets or ducting to allow both standard and high-cube containers to be stowed in any location.

3.1.11 The positions of supply air inlets and exhaust air outlets are to be such as to reduce the possibility of shortcycling. An adequate distance is to be maintained between inlet and outlet vents on the open deck.

3.1.12 The effect of warm exhaust air on deck-stowed refrigerated containers is to be taken into consideration. Similarly, the effect of warm exhaust air from deck-stowed refrigerated containers on the inlet air to the hold is to be considered.

3.1.13 Arrangements are to be provided to permit a rapid shutdown and effective closure of the ventilation system in each hold space in case of fire.

3.1.14 Ventilation ducts which penetrate the deck and/or hatch coaming, including dampers and / or closures, are to be made of steel and their arrangement is to be to the satisfaction of the relevant Administration. The use of nonmetallic flexible ducts, local to each container location, will be acceptable provided the material demonstrates suitable low flame spread characteristics.

3.2 Heat balance

3.2.1 The amount of heat absorbed from the hold space by each container, which is used to determine the design air change rate, is to be stated.

3.2.2 The heat gain or loss from all adjacent spaces, such as fuel oil tanks, ballast tanks, engine room, etc. is to be stated.

3.2.3 The heat rejection from the refrigeration unit of a standard TEU or FEU container when working at low temperature (minus 18°C), chill temperature (2°C) and banana carriage temperature (13°C), used to determine the design air change rate, is to be stated. The following FEU values may be used for guidance purposes:

Frozen cargo (minus 18°C/38°C). 7,0 kW

Chill cargo (2°C/38°C). 10,0 kW

Banana cargo (13°C/38°C). 13,0 kW.

3.2.4 The above heat rejection values are for the container during normal operation after the cooling down period of a non-precooled cargo.

3.2.5 The stowage ratio, for the carriage of containers at different internal temperatures, which is used to determine the design air change rate, is to be stated.

3.2.6 When an extraction ventilation system is proposed, a stack factor of 0,9 may be used in the heat balance calculations. If a ventilation system using supply air only is proposed, then no stack factor can be allowed.

3.3 Fan redundancy

3.3.1 A single supply or exhaust fan is not to be used for multiple container stack locations.

3.3.2 Individual container cells may be fed by a system having a single mechanical fan or fans to supply and/or extract air.

3.3.3 Installed standby fans are not required. However, a minimum of one replacement fan, or fan blade assembly and motor, of each size is to be carried onboard. Fans are to be arranged to enable each to be replaced whilst the remaining systems remain in operation.

3.4 Hull structures

3.4.1 Special consideration will be given to installations using hull spaces for air distribution, rather than dedicated ductwork.

3.4.2 Consideration is to be given to measures to prevent ingress of water into air inlets and exhaust outlets, where applicable.

■ Section 4 Electrical, including container plug-in sockets

4.1 General

4.1.1 In addition to the requirements of *Pt 6, Ch 2 Electrical Engineering*, the following are to be complied with:

- (a) Electrical power for the ventilation system is to be provided by one or more separate feeder circuit(s) from the main switchboard.
- (b) Under sea-going conditions, the number and rating of service generators are to be sufficient to supply all container plug-in socket outlets and the hold space ventilation system in addition to the ship's essential services, when any one generating set is out of action.

4.1.2 The choice between a low (440 V) or high (6,600 V) distribution system serving the container plug-in point is considered a purely commercial decision. Consideration needs to be given to the fault level of the generating equipment selected and the total generating capacity of the ship. Independent of the system voltage, only the dedicated plug-in socket outlet kW value will be stated in the notation.

4.1.3 Where a distribution system exceeding 1000 V a.c. is employed, the plug-in socket outlets for each hold space may be fed from a local transformer and the following are to be complied with:

- (a) Transformers are to be fed from individual circuits divided between different sections of the main switchboard.

(b) The electrical power for the ventilation system may be fed locally from each transformer.

4.1.4 Container plug-in socket outlets are to comply with the requirements of *Pt 6, Ch 2, 13.6 Socket outlets and plugs*.

4.2 Plug-in socket outlet supply transformers

4.2.1 A standby transformer serving the container plug-in socket outlets is to be provided. However, if the CRC notation is not assigned, then there is no specific requirement covering the installation of a standby power supply.

4.2.2 If a standby transformer is to be provided, then the exact requirements are open to interpretation and consideration should be given to the contents of IACS Unified Interpretation SC 83 with regard to the equipment provided.

4.3 Container plug-in socket outlets

4.3.1 The distribution and sub-circuit cabling for the container plug-in socket outlets is to be rated at the full load capacity (maximum rated capacity).

4.3.2 Groups of container plug-in socket outlets may be fed from a number of independent sub circuits.

4.3.3 Sub circuits are to be able to be individually switched, thus allowing a sequential start up after a prolonged (12 hours) blackout. A suitable procedure is to be proposed and approved that takes into consideration the requirements of *Pt 7, Ch 10, 4.4 Generated power for plug-in socket outlets* in addition to the requirements of *Pt 6, Ch 2 Electrical Engineering*.

4.4 Generated power for plug-in socket outlets

4.4.1 When determining the dedicated generating power for the plug-in socket outlets, the electrical power drawn by the refrigeration unit of a standard TEU and FEU refrigerated container when working at both low temperature (minus 18°C) and chill temperature (2°C), is to be stated.

4.4.2 The following values for various cargoes operating at normal design conditions may be used for guidance purposes:

4.4.3 Twenty foot equivalent unit (TEU):

Frozen cargo (minus 18°C/38°C)	5,5 kW
Chill cargo (2°C/38°C)	7,5 kW
Banana cargo (13°C/38°C)	<i>see Pt 7, Ch 10, 4.4 Generated power for plug-in socket outlets 4.4.5</i>

4.4.4 Forty foot equivalent unit (FEU) including high-cube containers:

Frozen cargo (minus 18°C/38°C)	8,5 kW
Chill cargo (2°C/38°C)	11,0 kW
Banana cargo (13°C/38°C)	<i>see Pt 7, Ch 10, 4.4 Generated power for plug-in socket outlets 4.4.5</i>

4.4.5 If the Owner, charterer or operator has operational data indicating that, for the ship's specific trade (for example banana only cargoes), the power provision for the refrigerated containers requirements exceeds those stated above, then these higher values should be substituted and submitted for consideration.

4.4.6 The above values are for the container during normal operation after the cooling-down period of a non-precooled cargo.

4.4.7 An overall diversity factor may be applied to the container's total power requirement. Consideration is to be given to *Pt 6, Ch 2, 5.6 Diversity factor*. This diversity factor is to be applied to all refrigerated container cell locations. For guidance purposes, the diversity factor is not generally to be less than 0,75.

■ Section 5**Instrumentation, control and alarm systems****5.1 General**

5.1.1 The alarm system is to indicate failure of each independent ventilation system in each hold space. If a balanced ventilation system is proposed, indication of failure for each individual part is to be given. The alarm system may be integral with the machinery space alarm system or, if fitted, the refrigerated container monitoring system.

5.1.2 Alarms are to be initiated in a manned location. Where alarms are displayed as group alarms in the main machinery space alarm system, provision is to be made to identify individual alarms at a separate control panel.

5.1.3 Alarms are to give both an audible and visual warning.

5.2 Hold space temperature monitoring

5.2.1 A minimum of two temperature sensors are to be provided in each hold space carrying refrigerated containers. The sensors are to be positioned to give an indication of the mean air temperature occurring in the hold space used for the carriage of refrigerated containers. Sensors are to be positioned so as not to be directly affected by warm air from the condensers.

5.2.2 The hold temperature is to be continually monitored. Temperatures are to be recorded, either automatically or manually as a hold temperature log. If temperatures are to be logged manually, then the mean temperature in each hold space is to be recorded.

5.2.3 If the mean hold space temperature rises above the design maximum, then an alarm is to be initiated.

5.3 Container refrigeration system alarms

5.3.1 These Rules do not cover any requirements for alarm and monitoring systems fitted to containers. It is acceptable to utilise the container power supply cables to transmit signals to a suitable receiver or data logger.

■ Section 6**Hold access and maintenance access arrangements****6.1 Hold pressure/vacuum**

6.1.1 The maximum permitted pressure or vacuum that may occur in the hold space is to be stated. It is proposed that a value, in accordance with the contents of *Pt 3, Ch 1, 9.6 Definitions and details of tests 9.6.4*, may be considered as a maximum value. An overpressure of 0,15 bar may be used for guidance purposes. If the ventilation system is capable of producing a positive pressure or vacuum in excess of the design allowable figure, then means are to be provided to protect the hold space against the effect of over pressure or vacuum. If axial supply fans are proposed, even if aerofoil fan blades are fitted, it is unlikely that the fans will be able to produce a pressure above 0,025 bar (250 mm water gauge).

6.1.2 If required, consideration is to be given to the use of a pressure or vacuum relief device or other arrangement set to operate below the maximum allowable hold pressure or vacuum.

6.1.3 The proposed pressure or vacuum relief device for each hold space is to be of adequate size.

6.2 Hold access arrangements

6.2.1 Suitable means are to be provided to allow personnel safe access to each hold space when the ventilation system is in operation. Consideration is to be given to the possible over pressure or partial vacuum that may occur in the hold space. The use of an airlock arrangement may need to be considered.

6.3 Maintenance access arrangements

6.3.1 Free access to each applicable container cell and hold space is to be provided to allow replacement of refrigeration equipment in the event of failure or malfunction.

6.3.2 Adequate access is to be provided to allow plugging in, data recording or retrieval and general maintenance of all deck- and hold-stowed refrigerated containers. Suitable means are to be provided to allow the removal of the compressor and electric motor from each refrigerated container.

6.3.3 Suitable safe access is to be provided to each tier of deck stowed refrigerated containers to allow electrical connection, monitoring and maintenance. The use of fixed platforms, such as lashing bridges, should be proposed where possible.

■ Section 7 Water cooler refrigeration units

7.1 Cooling water system

7.1.1 A minimum of two independently operated circulation pumps are to be installed. One of the pumps may be used for other services, such as a general service pump.

7.1.2 The capacity of each pump should be sufficient to supply each container at the required flow rate with an excess capacity of at least 10 per cent. This required flow rate should be obtained from the container manufacturer.

7.1.3 The fresh water system is to provide sufficient flow and even distribution to each container location. This is to be achieved using all possible combinations of fresh water pumps and dedicated refrigerated container cells.

7.1.4 The temperature of the cooling water is to be maintained in accordance with the container manufacturer's recommendations.

7.1.5 Flexible hoses are to be utilised for connecting the water supply and return pipes. The connectors on the ends of the flexible hoses are to be of a type that self-closes on disconnection. Adequate valves are to be provided to allow isolation of each cargo hold sub-circuit in the event of a leak or pipe fracture.

7.1.6 A minimum of two fresh-water to sea-water heat exchangers are to be provided. Each is to be rated at 100 per cent of the required cooling duty at the notation conditions. The second heat exchanger may be a standby or part of a common central system such as that used for main engine cooling duties. The heat exchangers are to be supplied by a minimum of two separate sea-water pumps.

7.1.7 If metal pipes are used, the contents of *Pt 5, Ch 12, 11.8 Metal pipes for fresh water services* are to be given due consideration.

■ Section 8 Deck-stowed refrigerated containers

8.1 General

8.1.1 Consideration is to be given to the effect of the warm air discharged from the condenser of each deckstowed refrigerated container. When refrigerated containers are stowed on only two tiers high, it is considered that the warm air from each condenser is dissipated without any undue effect on adjacent containers.

8.1.2 If containers are to be carried three or more tiers high, then consideration is to be given to limiting the effect of short-cycling warm discharge air within the central section of the stack. The proposed method or methods for dealing with this effect are to be stated. Possible options would include reserving the central cells of each stack for non-refrigerated containers, to reduce the block effect or providing fans and ductwork to supply ambient temperature air to the bottom of each vertical stack. Trials of any proposed system are to be undertaken.

8.1.3 Any adverse effect that the warm air discharged from the hold space ventilation system has on the deck stowed refrigerated containers is to be minimised. Similarly, the warm air discharged from the deck stowed refrigerated containers is to be shielded from entering the hold space ventilating system.

■ Section 9**Inspection and testing on completion****9.1 General**

9.1.1 On completion of construction and all appropriate safety checks, the acceptance tests prescribed in *Pt 7, Ch 10, 9.2 Acceptance tests* are to be carried out. Their purpose is to verify the correct functioning of the installation and its ability to maintain the air throughput required for the assignment of the intended class notation.

9.1.2 The proposed test schedules, including methods of testing and details of the test equipment to be provided are to be submitted to Lloyd's Register before the tests commence. The proposed test methods are to be appropriate for the design of the system installed and are to include such acceptance criteria as:

- (a) Volume of air to be supplied and/or exhausted at each container cell location.
- (b) Maximum allowable deviation from this air volume.
- (c) Maximum allowable pressure within the hold space when the system is under normal operating conditions.

9.1.3 Trials of the air distribution system within the hold spaces are to be witnessed by Lloyd's Register surveyors before the ship is put into service and prior to the **CRC** notation certificate being issued. These trials are to be in addition to any tests which may have been carried out whilst commissioning the system.

9.2 Acceptance tests

9.2.1 The acceptance tests (*see also Pt 7, Ch 10, 9.2 Acceptance tests 9.2.2 and Pt 7, Ch 10, 9.2 Acceptance tests 9.2.3*) are to comprise the following:

- (a) Control and alarm systems are to be tested to demonstrate that they operate correctly, *see also Pt 6, Ch 1, 2.3 Alarm systems, general requirements*.
- (b) The accuracy, calibration and functioning of all instrumentation is to be verified.
- (c) For supply air systems: Verification of each supply fan's output when running at maximum speed. Verification of the air discharge rate and operation of any distribution arrangements at each individual container cell location. During the test, all supply fans serving the hold space are to be operated simultaneously, thus replicating normal operating conditions. If a common or multiple supply fan distribution system is fitted, then the arrangements are to be verified; firstly, with all supply fans in operation and, secondly, with any one fan out of action.
- (d) For exhaust air systems: Verification of each exhaust fan's output when running at maximum speed. The volume of air being extracted from each individual container cell location is to be verified with each exhaust fan running at maximum speed. All exhaust fans serving the same hold space are to be operated simultaneously thus replicating normal operating conditions.
- (e) For combined supply and exhaust air systems: Verification of each supply and exhaust fan's output when both are running at maximum speed. The volume of air being supplied and extracted from each individual container cell location is to be verified. All fans serving the same hold space are to be operated simultaneously thus replicating normal operating conditions.
- (f) If the supply and/or exhaust ductwork is prefabricated and installed in one piece testing at the manufacturer's works may be accepted provided the following are considered:
 - Any change in the supply and/or exhaust fan(s) output due to differences in electricity supply.
 - Any de-rating of the fan throughput due to a back pressure or partial vacuum occurring within the hold space during normal operating conditions.
 - Verification of the test results is to be undertaken in a single hold space.
- (g) Where the air volume required to meet the class notation cannot be verified during testing for practical reasons, assignment of the notation is to be deferred until it is demonstrated that the system is able to achieve the specified air throughput within each hold space during a loaded passage.

9.2.2 Where a number of identical fan and ductwork installations are constructed and fitted within each hold space, the acceptance trials required in *Pt 7, Ch 10, 9.2 Acceptance tests 9.2.1* need only be carried out in two separate hold spaces, provided that the results are satisfactory.

9.2.3 Where the same system is installed on a number of identical sister ships for the same Owner and by the same shipyard, the testing in accordance with *Pt 7, Ch 10, 9.2 Acceptance tests 9.2.1* will only be required on the first ship of the series, provided that the results are satisfactory.

9.2.4 The effect of exhausting warm hold space ventilation air on the operation of the integral air-cooled condensers of deck stowed containers is to be established under normal operational conditions. The discharge from hold space discharges is to be suitably modified if necessary.

9.3 Testing of cooling water system

9.3.1 Cooling water piping that is welded *in situ* is to be hydraulically strength tested at 1,5 times the design pressure, but in no case less than 3,5 bar g.

9.3.2 A distribution test is to be carried out to ensure that even fresh water distribution to each container as well as sufficient flow is achieved. As the fresh water system may be somewhat complicated, this test should be carried out with care, using all possible combinations of fresh water pumps installed.

9.3.3 If required, the distribution test can be carried out without containers, utilising flexible hoses for connecting the water supply and return pipes together. The return valves should be partly closed or flexible pipe may be crimped to represent the condenser pressure drop. Water flow meters are to be installed at the highest and the lowest container levels to verify equal water flow.

9.3.4 The capacity of each pump should be measured by a flow meter with an accuracy of ± 3 per cent. Alternatively, this capacity could be obtained from the manufacturer's curves if the static pressure difference across a pump under test conditions is measured.

9.3.5 Sea-water pumps and heat exchangers are normally subjected to a functional test only.

■ Section 10 **Spare gear**

10.1 General

10.1.1 Adequate spares, together with the tools necessary for maintenance or repair of the ventilation systems are to be carried. The spares are to be determined by the Owner according to the design and intended service.

10.1.2 A minimum of one replacement fan, or complete fan impeller and motor assembly for each size fitted is to be carried onboard.

10.1.3 The maintenance of the spares is the responsibility of the Owner.

Arrangements and Equipment for Environmental Protection (ECO Class Notation)

Part 7, Chapter 11

Section 1

Section

- 1 **General requirements**
- 2 **Minimum requirements**
- 3 **Supplementary characters**
- 4 **Survey requirements**

■ Section 1 General requirements

1.1 Application

1.1.1 This Chapter contains requirements for the control of operational pollution.

1.1.2 Compliance with this Chapter is optional. An LR classed ship meeting the requirements of this Chapter will be eligible for **ECO** class notation, which will be recorded in the *Register Book*.

1.1.3 Additional requirements may be imposed by the National Administration with which the ship is registered and/or by the Authority within whose territorial jurisdiction it is intended to operate. Where such additional requirements are relevant to the ship, compliance with those Regulations is the responsibility of the Owner. If specifically requested, Lloyd's Register may provide suitable certification or statement of compliance.

1.1.4 Lloyd's Register is to be advised of any matter that relates to the environmental performance of the ship that would affect the assignment of the **ECO** class notation.

1.2 ECO class notation: minimum requirements and additional characters

1.2.1 *Pt 7, Ch 11, 2 Minimum requirements* states the minimum requirements to be met for assignment of the **ECO** notation.

1.2.2 *Pt 7, Ch 11, 3 Supplementary characters* contains additional requirements. Ships complying with these requirements will be eligible for one or more of the following associated supplementary characters, as applicable:

A Anti-fouling coatings.

BIO Bio-fouling.

BWT Ballast water treatment.

CRM Cargo residue minimisation.

EEDI-1, EEDI-2, EEDI-3 Energy efficiency design index.

SEEMP, EnMS Ship energy efficiency management.

GW Grey water.

IBTS Integrated Bilge Water Treatment System.

IHM Inventory of hazardous materials.

NO_{x1}, NO_{x2}, NO_{x3} Nitrogen Oxides (NO_x) exhaust emissions.

OW Oily bilge water.

P Protected oil tanks.

R Refrigeration systems.

SO_x, DIST Sulphur Oxides (SO_x) exhaust emissions.

TC Enhanced tank cleaning.

VECS-L, VOC-R Vapour emission control systems (tankers only).

Arrangements and Equipment for Environmental Protection (ECO Class Notation)

Part 7, Chapter 11

Section 1

1.3 Transfer of class ships

1.3.1 A ship classed with another IACS class society that transfers to LR class will be eligible for the class notation **ECO(TOC)** if it holds the previous society's environmental class notation at the time of the transfer of class. However, ships with **ECO(TOC)** notation are not eligible for any of the supplementary characters listed in *Pt 7, Ch 11, 1.1 Application 1.1.2*.

1.3.2 To maintain the **ECO(TOC)** notation a ship must implement and maintain the operational procedures listed in *Pt 7, Ch 11, 1.5 Information to be submitted 1.5.4*, as applicable.

1.4 Definitions

1.4.1 The following definitions are applicable:

- **Animal carcasses** means the bodies of any animals that are carried on board as cargo and that die or are euthanised during the voyage.
- **Antifouling Convention** means the International Convention on Control of Harmful Antifouling Systems on Ships. This Convention prohibits the use of organotin anti-fouling systems on ships and was adopted by the International Maritime Organization (IMO) in October 2001.
- **Ballast Water Convention** means the International Convention for the Control and Management of Ships' Ballast Water and Sediments. This international legislation was developed by the IMO to regulate discharges of ballast water and reduce the risk of introducing nonnative species from ships' ballast water.
- **Cargo Residues** means the remnants of any cargo which is not covered by other Annexes to MARPOL and which remains on the deck or in holds following loading or unloading, including loading and unloading excess or spillage, whether in wet or dry conditions or entrained in wash water. This does not include cargo dust remaining on the deck after sweeping or dust on the external surfaces of the ship.
- **Cooking oil** means any type of edible oil or animal fat used or intended to be used for the preparation or cooking of food. This does not include the food that is prepared using these oils.
- **Domestic wastes** mean all types of wastes not covered by other Annexes that are generated in the accommodation spaces on board the ship. Domestic waste does not include grey water.
- **Garbage** means all kinds of food wastes, domestic wastes and operational wastes, all plastics, cargo residues, cooking oil, fishing gear, and animal carcasses generated during the normal operation of the ship and is liable to be disposed of continuously or periodically, except where those substances are defined or listed in other Annexes to MARPOL. Garbage does not include fresh fish and parts thereof which are generated as a result of fishing activities undertaken during the voyage, or as a result of aquaculture activities which involve the transport of fish, including shellfish for placement in the aquaculture facility and the transport of harvested fish, including shellfish from such facilities to shore for processing.
- **Geometric mean** means the n th root of the product of n numbers.
- **Grey water** is drainage from dishwater, galley sink, shower, laundry, bath and washbasin drains and does not include drainage from toilets, urinals, hospitals, and animal spaces, as defined in *Regulation 1 - Definitions* of MARPOL Annex IV and does not include drainage from cargo spaces.
- **Incinerator ashes** means ash and clinkers resulting from shipboard incinerators used for the incineration of garbage.
- **Leakage detection system** means a calibrated mechanical, electrical or electronic device for detecting leakage of refrigerant gases which, on detection, alerts the operator.
- **MARPOL or MARPOL 73/78** is the International Convention for the Prevention of Pollution from Ships, 1973 as modified by the Protocol of 1978.
- **Operational wastes** means all solid wastes (including slurries) not covered by other Annexes that are collected on board during normal maintenance or operations of a ship, or used for cargo stowage and handling. Operational wastes also include cleaning agents and additives contained in the cargo hold and external wash water. Operational wastes do not include grey water, bilge water, or other similar discharges essential to the operation of a ship, taking into account the guidelines developed by the Organisation.
- **Operator** means the natural or legal person exercising actual power over the technical functioning of the equipment and systems.
- **Refrigerant system log book** means a method of maintaining a record of maintenance, calibration, refrigerant charging, leak detection, recovery, etc. The log book may take the form of a stand-alone book, a series of log sheets or form part of the engine room log.
- **SEEMP** means a Ship Energy Efficiency Management Plan, and is a ship-specific manual which aims to improve the energy efficiency of ship operations.

Arrangements and Equipment for Environmental Protection (ECO Class Notation)

Part 7, Chapter 11

Section 1

- **Thermotolerant coliforms** is the group of coliform bacteria which produce gas from lactose in 48 hours at 44,5°C. They are also referred to as 'faecal coliforms'; however, the term 'thermotolerant coliforms' is now accepted as more appropriate, since not all of these organisms are of faecal origin.
- **VECS** means vapour emission control system.
- **VOC** means volatile organic compound.

1.5 Information to be submitted

1.5.1 The following are to be submitted:

- (a) One copy of every Certificate listed in *Pt 7, Ch 11, 1.5 Information to be submitted 1.5.3*.
- (b) Two copies of the Operational Procedures listed in *Pt 7, Ch 11, 1.5 Information to be submitted 1.5.4*.
- (c) One copy of all plans and information listed in *Pt 7, Ch 11, 1.5 Information to be submitted 1.5.5*.

1.5.2 For existing ships the certificates, information and plans listed in *Pt 7, Ch 11, 1.5 Information to be submitted 1.5.3* are to be submitted for approval prior to the **ECO** Initial Survey for assignment of the **ECO** notation, see *Pt 7, Ch 11, 4.1 Initial Survey and Audit 4.1.1*. For new ships, information and plans listed in *Pt 7, Ch 11, 1.5 Information to be submitted 1.5.3* and *Pt 7, Ch 11, 1.5 Information to be submitted 1.5.5* are to be submitted for approval prior to the **ECO** Initial Survey. However, the operational procedures listed in *Pt 7, Ch 11, 1.5 Information to be submitted 1.5.4* may be submitted up to six months after the ship enters into service.

1.5.3 Certificates:

- (a) MARPOL certificates or statements on behalf of the ship's Flag State, including:
 - Engine International Air Pollution Prevention (EIAPP) Certificate or Statement of Compliance with the NO_x emission requirements of MARPOL *Annex IV of MARPOL 73/78 Regulations for the Prevention of Pollution by Sewage from Ships* for each engine to which *Regulation 13 – Nitrogen Oxides (NO_x)* applies;
 - International Energy Efficiency Certificate.
- (b) Safety Management Certificate (SMC) and Document of Compliance (DOC) in accordance with the International Safety Management Code (ISM Code).
- (c) Incinerator Type Approval Certificate or equivalent, as required by *Pt 7, Ch 11, 2.9 Garbage handling and disposal 2.9.2*.
- (d) TBT-free anti-fouling system certificate.
- (e) Sewage system and, where fitted, sewage treatment system statement of compliance with the requirements of USCG 33 CFR 159 and/or MARPOL *Annex IV of MARPOL 73/78 Regulations for the Prevention of Pollution by Sewage from Ships*.
- (f) Vapour emission control system certificate or statement of compliance with the requirements of USCG 46 CFR 39 or the IMO Standards for Vapour Emission Control Systems (*MSC/Circular.585 – Standards for Vapour Emission Control Systems – (Adopted on 16 April 1992)*) (oil tankers carrying crude oil only).
- (g) VOC reducing device Type Approval Certificate or equivalent as required by (supplementary character **VOC-R**).
- (h) ISO 50001 (Energy Management) Certificate, issued by an accredited organisation (supplementary character **EnMS** only).

1.5.4 Operational procedures:

- (a) Procedures to be adopted to ensure that the ship's NO_x certification is maintained.
- (b) Fuel oil management for the control of SO_x emissions.
- (c) Refrigerant management including adding and recovering refrigerant charge, leak detection and sample log book.
- (d) Retention and disposal of spilled or spent foam, chemical or liquid based fire-fighting media, as applicable.
- (e) Oil pollution prevention measures.
- (f) Garbage management.
- (g) Sewage treatment and discharge control.
- (h) Precautionary measures to minimise the transfer of non-native organisms in ballast water.
- (i) Ballast Water Management Plan (all ships).
- (j) Ship Energy Efficiency Management Plan.
- (k) Vapour management plan (tankers carrying crude oil only).
- (l) Grey water treatment or holding and discharge (supplementary character **GW** only).
- (m) Procedures for maintaining inventory of hazardous materials (supplementary character **IHM** only).

1.5.5 Information and plans:

Arrangements and Equipment for Environmental Protection (ECO Class Notation)

Part 7, Chapter 11

Section 2

- (a) SERS registration number or statement of membership of alternative scheme from IACS Member service provider.
- (b) Details of engine make and model, rated power, rated speed and duty cycle for all installed engines falling within the scope of MARPOL Annex VI, *Regulation 13 – Nitrogen Oxides (NOx)*.
- (c) Description of the method(s) by which the NO^x certified value has been achieved. The supplementary characters (**NOx-1** and **NOx-2**) and NO^x Technical File for the engine plus NO^x reducing device (**NOx-3** supplementary character).
- (d) Details and location of each permanently installed refrigeration system (including those used for cargo temperature control, air conditioning, provision rooms and chiller units).
- (e) Mass of refrigerant charge in each system and the refrigerant designation (e.g. R-134a) in accordance with ISO 817.
- (f) Refrigerant plant general arrangement drawing showing number and locations of the refrigerant leak detectors.
- (g) Details of fire-extinguishing media to be used in fixed fire-fighting systems and portable extinguishers.
- (h) Bilge holding, waste oil and sludge tank capacities and piping arrangements.
- (i) Arrangements of non-cargo oil loading and discharge connections together with associated drip trays and drainage systems.
- (j) Fuel oil storage, settling and service tank high level alarms/overflow systems.
- (k) Cargo and ballast tank arrangements (tankers only).
- (l) Cargo and ballast piping system plans, including cargo tank overfill prevention arrangements (tankers only).
- (m) Arrangements of tanker cargo manifolds together with associated drip trays and drainage systems.
- (n) Details of sewage treatment and handling systems.
- (o) Capacity of sewage holding and/or treatment system.
- (p) Maximum numbers of crew and passengers.
- (q) Details of incinerator arrangements, as applicable, associated piping systems, control and monitoring equipment.
- (r) Hull coating system.
- (s) Ballast water treatment arrangements, as applicable (for supplementary **BWT** character only).
- (t) Lubricants' technical data sheet(s) and letter/Statement(s) from original equipment manufacturer(s) for each oil-to-sea interface where EAL's are applied (e.g. stern tube) to declare compatibility with the specified Environmentally Acceptable Lubricant(s) and detailed drawings of the component(s) 'interfacing' with such lubricants (supplementary character **EAL** only).
- (u) Energy Efficiency Design Index Statement of Compliance or certificate (supplementary characters **EEDI-1**, **EEDI-2** and **EEDI-3** only).
- (v) Details of grey water treatment plant and effluent quality (for supplementary **GW** character only).
- (w) Inventory of Hazardous Materials Statement of Compliance.
- (x) Arrangements for protected oil tanks (for supplementary **P** character only).
- (y) Shadow area diagrams (supplementary character **TC** only).
- (z) Details of self-contained vapour recovery systems, where fitted, required for **VOC-R** character; for tankers carrying crude oil as applicable (see *Pt 7, Ch 11, 2.13 VOC management 2.13.2*); and for **VECS-L** character as applicable (see *Pt 7, Ch 11, 3.17 Vapour emission control systems – VECS-L, VOC-R characters 3.17.3*).
- (aa) LR Statement of SEEMP conformance and associated documentation (supplementary character **SEEMP** only).
- (ab) Any information relating to the environmental performance of the ship, which may influence the assignment of the **ECO** notation.

1.6 Alterations and additions

1.6.1 When an alteration, amendment, deletion or addition to the approved arrangements and procedures is proposed, appropriate details are to be submitted for approval.

■ Section 2 Minimum requirements

2.1 General

2.1.1 It is a prerequisite for assignment of the **ECO** notation that the ship:

Arrangements and Equipment for Environmental Protection (ECO Class Notation)

Part 7, Chapter 11

Section 2

- (a) complies with the Anti-fouling Convention, the Ballast Water Convention, except as modified by *Pt 7, Ch 11, 2.12 Ballast water 2.12.4*, and all Annexes to *MARPOL - International Convention for the Prevention of Pollution from Ships 73/78*, as amended, applicable to the ship;
- (b) has a valid Safety Management Certificate (SMC), in accordance with the ISM Code issued by the Flag State Administration with which the ship is registered or a duly authorised organisation complying with *IMO Resolution A.739(18) – Guidelines for the Authorization of Organizations Acting on Behalf of the Administration – (Adopted on 4 November 1993) Amended by Resolution MSC.208(81)* and authorised by the National Authority with which the ship is registered; and
- (c) is enrolled in LR's Ship Emergency Response Service (SERS) or the equivalent scheme of another IACS Member.

2.1.2 Where a ship, by virtue of its gross tonnage, is not required by the MARPOL Convention to have MARPOL Certification, the following are to be maintained:

- (a) An Oil Record Book in accordance with *MARPOL Annex I of MARPOL 73/78 Regulations for the Prevention of Pollution by Oil*.
- (b) A garbage management plan and record book in accordance with *MARPOL Revised Annex V of MARPOL 73/78 Regulations for the Prevention of Pollution by Garbage from Ships*.

2.1.3 Where a ship, by virtue of its gross tonnage, is not required by the Antifouling Convention to have certification, an antifouling system (AFS) declaration in the format shown in Appendix 2 of Annex 4 to the Convention is to be maintained onboard.

2.1.4 Where a ship, by virtue of its gross tonnage is not required to have a SMC, it is exempt from *Pt 7, Ch 11, 2.1 General 2.1.2*.

2.1.5 High speed craft, as defined in LR's *Rules and Regulations for the Classification of Special Service Craft* and non-tank ships less than 400 gross tonnes, will be the subject of special consideration.

2.1.6 Offshore supply vessels that are less than 100 m in length, as per *MSC 235(82)*, are exempt from the requirement to be enrolled in LR's Ship Emergency Response Service (SERS) or the equivalent scheme of another IACS member.

2.2 Nitrogen oxides (NO_x)

2.2.1 These requirements apply to all installed diesel engines with an individual output power greater than 130 kW, other than those used solely for emergency purposes on the ship on which the engine is installed. There are no specific requirements relating to NO_x emissions from boilers, incinerators or gas turbine installations.

2.2.2 All engines falling within the scope of *MARPOL Annex VI, Regulation 13 – Nitrogen Oxides (NO_x)* are to comply with its provisions and meet the NO_x emission limits applicable to the date of construction of the ship or, where relevant, the engine installation date.

2.2.3 **EIAPP** certification or Statement of Compliance is to be issued by, or on behalf of, the Flag State.

2.2.4 Alternative arrangements providing an equivalent level of environmental protection will be considered.

2.3 Sulphur oxides (SO_x)

2.3.1 Emissions of SO_x are to be controlled by limiting the sulphur content of fuel oils used on board.

2.3.2 The maximum sulphur content of fuel oil to be used on board is not to exceed 3,00 per cent m/m.

2.3.3 Where the grade of fuel normally used cannot be obtained with the appropriate fuel sulphur level, then a better grade of fuel meeting this requirement will need to be purchased.

2.3.4 A fuel oil management system is to detail the maximum sulphur content to be specified when ordering fuel oils and the means adopted to verify that the sulphur content of fuel oils supplied meets that requirement. This management system is to include the practices to be adopted to ensure that appropriate low sulphur fuel oils are used when the ship is within IMO designated 'Emission Control Areas established for SO_x and particulate matter control' and/or the jurisdiction of other local, national or regional 'SO_x Emission Control regimes' as applicable.

2.3.5 Where testing to determine the sulphur content of fuel received on board is to be carried out, a representative sample is to be drawn at the time of delivery from the ship's bunker manifold using the manual or automatic sampling methods defined in ISO 3170 or 3171, or their national respective equivalents. Fuel sulphur content is to be subsequently determined using the laboratory test method *ISO 8754:2003 Determination of sulphur content – Energy-dispersive X-ray fluorescence spectrometry*.

Arrangements and Equipment for Environmental Protection (ECO Class Notation)

2.3.6 Alternative arrangements providing an equivalent level of environmental protection will be considered. If an exhaust gas cleaning system is fitted, it is to be certified to *Resolution MEPC.184(59) – 2009 Guidelines for Exhaust Gas Cleaning Systems – (adopted on 17 July 2009)*.

2.4 Energy management

2.4.1 A Ship Energy Efficiency Management Plan (SEEMP) is to be retained on board according to the provisions of *Regulation 22 - Ship Energy Efficiency Management Plan (SEEMP) of MARPOLAnnex VI - Regulations for the Prevention of Air Pollution from Ships* and subsequently be reviewed by LR.

2.4.2 The SEEMP is to be developed in accordance with *Resolution MEPC.213(63) – 2012 Guidelines for the Development of a Ship Energy Efficiency Management Plan (SEEMP) – (Adopted on 2 March 2012)*.

2.5 Refrigeration systems

2.5.1 These requirements apply to all permanently installed refrigeration and air conditioning installations on board. These requirements do not apply to stand-alone refrigerators, freezers and ice makers used in galleys, pantries, bars and crew accommodation.

2.5.2 The use of chlorofluorocarbons (CFC) in existing, and hydrochlorofluorocarbons (HCFCs) in new, refrigeration or air conditioning installations is prohibited.

2.5.3 If halocarbon refrigerants are used, they are to have an Ozone Depleting Potential (ODP) rating of zero and a Global Warming Potential (GWP) of less than 1950, based on a 100- year time horizon.

2.5.4 Systems are to be arranged with suitable means of isolation so that maintenance, servicing or repair work may be undertaken without releasing the refrigerant charge into the atmosphere. Unavoidable minimal releases are acceptable when using recovery units.

2.5.5 For the purposes of refrigerant recovery, the compressors are to be capable of evacuating a system charge into a liquid receiver. Additionally, recovery units are to be provided to evacuate a system either into the existing liquid receiver or into cylinders dedicated for this purpose. The number of cylinders is to be sufficient to contain the complete charge between points of isolation in the system.

2.5.6 Where different refrigerants are in use they are not to be mixed during evacuation of systems.

2.5.7 Refrigerant leakage is to be minimised by leak prevention and periodic leak detection procedures. The frequency of leak detection and the maximum allowable annual leakage rate is dependent on the charge of each system and is specified in *Table 11.2.1 Refrigerant leak testing - maximum periodicity*.

Table 11.2.1 Refrigerant leak testing - maximum periodicity

Charge size	Periodicity	Leakage
under 3 kg	6 months	10%
3–30 kg	3 months	10%
30–300 kg	Monthly	5%
Over 300 kg	Monthly	<3%

2.5.8 Records are to be maintained demonstrating that leak testing is carried out in accordance with the periodicity specified in *Table 11.2.1 Refrigerant leak testing - maximum periodicity* by qualified personnel holding relevant certification, using either direct or indirect measuring methods and calibrated instruments where applicable.

2.5.9 A leak detection system appropriate to the refrigerant is to be provided to monitor continuously the spaces into which the refrigerant could leak. An alarm is to be activated to give warning in a permanently manned location when the concentration of refrigerant in the space exceeds a predetermined limit, (25 ppm for ammonia; 300 ppm for halogenated fluorocarbons). Remedial measures to repair the leakage are to be implemented as soon as practicable after an alarm is activated. Each leak detection system is to be checked at least once every 12 months to ensure proper functionality. The system is to be maintained and calibrated in accordance with the manufacturer’s recommendations and recorded in the log book.

2.5.10 Procedures for refrigerant management including adding and recovering refrigerant charge, leak detection and the means adopted to control the loss and leakage of refrigerants are to be established and implemented.

Arrangements and Equipment for Environmental Protection (ECO Class Notation)

Part 7, Chapter 11

Section 2

2.5.11 Refrigerant inventory and log book records are to be maintained covering:

- (a) Refrigerant added to each system.
- (b) Refrigerant leaks, including remedial actions.
- (c) Refrigerant recovered and storage location.
- (d) Refrigerant disposal including quantity and location.
- (e) Details of personnel suitably experienced or with an applicable qualification for maintenance of the onboard refrigerant system(s), including relevant certification.

2.5.12 After a leak has been identified, repaired and recorded it is to be rechecked prior to the system entering normal service. All applications, independent of charge size, are to be checked for leakage within one month after a leak has been repaired to ensure that the repair remains effective.

2.5.13 Records demonstrating the implementation of the operational procedures specified in *Pt 7, Ch 11, 2.5 Refrigeration systems 2.5.10*, as applicable, are to be maintained. These records are to be kept on board for a minimum period of three years, in a readily accessible form, and are to be available for inspection by LR Surveyors, as required.

2.5.14 A refrigerant log book is to be maintained for the lifetime of the system. It must record the quantity and type of refrigerant installed and the quantities added and recovered during servicing, maintenance and final disposal.

2.5.15 All personnel involved in the following activities must be suitably experienced or possess an applicable qualification:

- (a) installation, servicing or maintenance of the refrigeration equipment covered by the **ECO** Notation;
- (b) checking such equipment for any leakages of refrigerant gases; or
- (c) repairing, or carrying out work to prevent, such leakages.

2.6 Fire-fighting systems

2.6.1 The use of halon or halo-carbons as the fire-extinguishing medium in fixed fire-fighting systems or portable extinguishers is not permitted.

2.6.2 Where foam concentrates or other chemical or liquid based fire-fighting media with the potential to cause environmental pollution are used, instructions and procedures are to be provided for the safe containment and disposal of spilled media and other contaminated products during routine maintenance and, where practicable, following emergency use.

2.7 Oil pollution prevention

2.7.1 All ships are to comply with the requirements of *Pt 7, Ch 11, 2.7 Oil pollution prevention 2.7.2 to Pt 7, Ch 11, 2.7 Oil pollution prevention 2.7.12*. In addition, tankers are to comply with the requirements of *Pt 7, Ch 11, 2.8 Arrangements on ships carrying oil cargoes in bulk*.

2.7.2 Drainage from machinery space bilges is to be discharged to sea in accordance with the requirements of MARPOL 73/78, *Annex I of MARPOL 73/78 Regulations for the Prevention of Pollution by Oil* or retained onboard for discharge ashore.

2.7.3 The oil-in-water content of the water discharged is to be less than 15 ppm. Oily bilge water is to be discharged through approved oil filtering equipment and a 15 ppm alarm combined with a device for automatically stopping any discharge to sea when the oil content in the discharge exceeds 15 ppm. Full records of all discharges are to be kept.

2.7.4 The loading or discharge connections and vent pipes/overflows associated with fuel oils, lubricating oils, hydraulic oils and other oils are to be fitted with drip trays. Drip trays fitted to loading or discharge connections are to be fitted with closed drainage systems except on tankers where alternative arrangements will be considered.

2.7.5 Fuel oil storage, settling and service tanks are to be fitted with high level alarms and/or acceptable overflow systems.

2.7.6 The tank arrangement and engine room management procedures are to ensure that any leakages and waste oil from machinery and equipment are collected prior to disposal ashore or incineration. At all times, there is to be sufficient capacity to store a complete lubricating oil charge from the largest engine used for propulsion or electrical generating purposes. The tank arrangement is to allow the lubricating oil charge subsequently to be renovated or to be discharged ashore.

2.7.7 For those ships which only operate on distillate fuel, the tank arrangements in *Pt 7, Ch 11, 2.7 Oil pollution prevention 2.7.6* and sludge tanks may be combined to form a single tank. Where such a combined tank is fitted, the total capacity is to be equal to or greater than the aggregated total of the required individual tank capacities.

2.7.8 The bilge holding tank, the tank arrangements in *Pt 7, Ch 11, 2.7 Oil pollution prevention 2.7.6* and the sludge tank are to be arranged to facilitate the periodic removal of accumulated sediments and other material.

Arrangements and Equipment for Environmental Protection (ECO Class Notation)

Part 7, Chapter 11 Section 2

2.7.9 Discharge piping systems to deck from the bilge holding tank, and the tank arrangements in *Pt 7, Ch 11, 2.7 Oil pollution prevention 2.7.6*, are to be separate from the fuel oil loading and transfer systems. Their piping systems are to be terminated with the standard discharge connections specified in MARPOL Annex I, *Regulation 13 - Standard discharge connection*.

2.7.10 Means are to be provided for the collection and recovery of any oil spilled on decks.

2.7.11 For ships delivered after 1 August 2010, fuel oil tanks with a capacity of greater than 60 m³, except overflow tanks, are to be located in a protected location away from the ship's side or bottom shell plating. Tanks are to be located in accordance with the requirements relating to fuel oil tank protection given in MARPOL Annex I, *Regulation 12A - Oil fuel tank protection*.

2.7.12 Procedures covering the handling of all oils and oily wastes are to be established and implemented. As a minimum, these are to cover:

- (a) loading, storage and transfer of fuel oils, lubricants, hydraulic oil, thermal heating oil and drummed oil products;
- (b) storage, transfer, discharge and disposal of oily mixtures contained in the ship's sludge, bilge holding and waste oil tanks and machinery space bilges;
- (c) recovery of any oil spilled on decks.

2.8 Arrangements on ships carrying oil cargoes in bulk

2.8.1 The constructional requirements of MARPOL Annex I, *Regulation 19 - Double hull and double bottom requirements for oil tankers delivered on or after 6 July 1996* and *Regulation 20 - Double hull and double bottom requirements for oil tankers delivered before 6 July 1996*, as applicable, are to apply to all oil tankers greater than 600 tonnes deadweight.

2.8.2 Cargo tanks are to be fitted with high level alarms and/or acceptable overflow systems.

2.8.3 The cargo area is to have arrangements to collect accidental outflow of oil under overfilling conditions. Accidental oil spills are to be discharged to a slop tank or collecting tank. These tanks are not to be located in the double hull space.

2.8.4 Cargo tank ballasting arrangements and segregated ballast systems are to be connected to separate and distinct sea chests.

2.8.5 A non-return valve is to be provided to isolate the cargo piping system from the sea connections.

2.8.6 Cargo manifold connections are to be fitted with drip trays with closed drainage systems.

2.8.7 Cargo manifold terminal pieces are to be designed, where practicable, in accordance with the relevant Oil Companies International Marine Forum (OCIMF) Recommendations for tanker manifolds and associated equipment.

2.8.8 Procedures covering ship to ship transfer of bulk liquid cargoes are to be established for ships engaged in the transfer of oil cargo at sea (STS Operations as defined in MARPOL Annex 1 Ch 8 *Regulation 40 - Scope of application, Regulation 41 - General Rules on safety and environmental protection* and *Regulation 42 - Notification*). These are to be agreed with LR, and implemented.

2.9 Garbage handling and disposal

2.9.1 A garbage management plan, developed in accordance with IMO *Resolution MEPC.201(62) - Amendments to the Annex of the Protocol of 1978 Relating to the International Convention for the Prevention of Pollution from Ships, 1973 - (Revised MARPOL Annex V) - (Adopted on 15 July 2011)*, is to be available and implemented. This plan, *inter alia*, shall include:

- (a) identification of the sources of garbage;
- (b) means of minimising garbage production;
- (c) procedures for the safe and hygienic collection, segregation, storing, processing and disposal of garbage, including the use of the equipment (compactors, comminuters, incinerators or other devices) on board. These procedures are to cover all garbage generated during the normal operation of the ship. The disposal of the following materials is to be specifically covered:
 - Cargo residues.
 - Cargo associated wastes.
 - Waste oil.
 - Paint and painting materials.
 - Medical wastes.
 - Large metal objects such as oil drums and machinery components.

Arrangements and Equipment for Environmental Protection (ECO Class Notation)

- Ropes: metal, synthetic or natural fibre.
- Rust/scale debris.
- Ballast tank sediments.
- Equipment containing refrigerants.
- Plastic.
- Food waste.
- Cooking oil.
- Domestic waste.
- Fishing gear.
- Operational waste.
- Incinerator ashes.
- Animal carcasses.

2.9.2 Where fitted, incinerators are to be designed and constructed in accordance with the requirements of *Resolution MEPC.76(40) - Standard Specification for Shipboard Incinerators - (adopted on 25 September 1997) Amended by Resolution MEPC.93(45)*. A type approval certificate issued by Lloyd's Register, another IACS Member or the relevant Flag State Administration is to be provided. As an alternative, a Declaration of Conformity issued under the EU Marine Equipment Directive is acceptable.

2.9.3 Where incineration is to be carried out, procedures are to be developed and implemented, covering:

- (a) operation, documentation and training in accordance with the requirements of MARPOL Annex VI, *Regulation 16 – Shipboard Incineration*, irrespective of ship construction or incinerator installation date; and
- (b) prevention of incineration within areas where incineration is prohibited by the Coastal State Administration.

2.9.4 Cargo residues are included in the definition of garbage within the meaning of revised Annex V, *Regulation 1 - Definitions* and may be discharged in accordance with *Regulation 4 Discharge of garbage outside special areas* and *Regulation 6 Discharge of garbage within special areas*. However, cargo material contained in the cargo hold bilge water should not be treated as cargo residues if the cargo material is not harmful to the marine environment and the bilge water is discharged from a loaded hold through the ship's fixed piping bilge drainage system.

2.9.5 The discharge of cargo residues is to be based on the physical, chemical and biological properties of the substances and may require special handling not normally provided by reception facilities, although ports receiving such cargoes should have adequate reception facilities for all relevant residues, including when entrained in wash water.

2.10 Sewage treatment

2.10.1 Where fitted, the sewage treatment system is to be approved in accordance with MEPC Resolution 159(55). As an alternative, a Declaration of Conformity issued under the EU Marine Equipment Directive is acceptable.

2.10.2 The capacity of the sewage treatment system is to be sufficient for the maximum number of persons on board. Where 'black water' only is treated, the minimum capacity is to be 115 litres/person/day for a conventional flushing system or 15 litres/person/day for a vacuum system. Where both 'black water' and 'grey water' are treated, an additional allowance of 135 litres per person, per day is to be made.

2.10.3 Procedures for the operation of a sewage treatment system, including the certification of performance, are to be established and implemented. Records are to be maintained of maintenance, repair, remedial work and disinfectant dosing rates.

2.10.4 The manufacturer's restriction on materials, which may be disposed of through the sewage treatment system, are to be clearly displayed at each input point.

2.10.5 The disinfectant dosing points of the sewage treatment system are to be readily accessible. Ready access is also to be provided for the taking of samples.

2.10.6 As an alternative to treatment, sewage and/or grey water may be retained on board. The sewage holding tank(s) and grey water holding tank(s) are to be of adequate capacity, taking into account the operation of the ship, the number of persons on board and other relevant factors (see guidance figures in *Pt 7, Ch 11, 2.10 Sewage treatment 2.10.2*). The tank is to be fitted with a visual contents gauge and a high level alarm.

2.10.7 Means are to be provided to aerate holding tanks to prevent the development of anaerobic conditions, taking into account *MSC/Circular.648 – Guidelines for the Operation, Inspection and Maintenance of Ship Sewage Systems – (Adopted on 6 June 1994)*.

2.10.8 Records are to be maintained detailing discharges from the holding tank. These are to include:

Arrangements and Equipment for Environmental Protection (ECO Class Notation)

Part 7, Chapter 11 Section 2

- (a) the date, location and quantity of sewage discharged from the holding tank either ashore or at sea in accordance with *Resolution MEPC.157(55) - Recommendation on Standards for the Rate of Discharge of Untreated Sewage from Ships - (Adopted on 13 October 2006)*;
- (b) rate of discharge of raw sewage;
- (c) distance from land and ship's speed, when sewage is discharged to sea.

2.10.9 Ventilation pipes from the sewage system are to be independent of other vent systems.

2.10.10 A suitable piping system from the sewage treatment system or holding tank is to be provided to allow discharge from the system/tank to shore reception facilities. The systems discharge pipe is to terminate with a standard discharge connection complying with the requirements of MARPOL Annex IV, *Regulation 10 - Standard Discharge Connections*.

2.10.11 Procedures for the cleaning and safe entry of sewage treatment systems and holding tanks, including the use of suitable personal protective equipment, are to be provided and implemented.

2.11 Hull anti-fouling systems

2.11.1 The application of anti-fouling systems containing TBT above the level specified in the Antifouling Convention is prohibited.

2.12 Ballast water

2.12.1 All ships carrying ballast water, to which the Ballast Water Convention applies, are to have on board, and to implement, a ballast water management plan approved by LR or by another IACS member.

2.12.2 The ballast water management plan is to meet the requirements of *Regulation B-1 - Ballast Water Management Plan* of the International Convention for the Control and Management of Ships' Ballast Water and Sediments, 2004 and encompass the recommendations in *IMO Resolution MEPC.127(53) - Guidelines for Ballast Water Management and Development of Ballast Water Management Plans (G4) - (Adopted on 22 July 2005)*.

2.12.3 For new ships intending to undertake ballast water exchange, the guidance on ballast water exchange design and construction standards within *IMO Resolution MEPC.149(55) - Guidelines for Ballast Water Exchange Design and Construction Standards (G11) - (Adopted on 13 October 2006)* is to be taken account of, as far as practicable.

2.12.4 A ship should carry out ballast water exchange in accordance with the convention; however, a ballast water treatment system is not required to be installed and used until such time as required by Regulation B-3 of the Convention and the Convention has entered into force.

2.12.5 A ballast water record book is to be kept on board and is to be used to record all ballast water operations.

2.13 VOC management

2.13.1 Tankers carrying crude oil are required to develop and implement a VOC Management Plan in accordance with IMO Guidelines for the Development of a Volatile Organic Compound (VOC) Management Plan for tankers carrying crude oil (*Resolution MEPC.185(59) - Guidelines for the Development of A VOC Management Plan - (Adopted on 17 July 2009)*) that has been approved by LR or by, or on behalf of, the ship's Flag State.

2.13.2 For all tankers carrying crude oil, a Vapour Emission Control System is to be fitted which has been designed and constructed in accordance with the requirements of USCG 46, CFR 39 or the IMO Standards for Vapour Emission Control Systems (*MSC/Circular.585 - Standards for Vapour Emission Control Systems - (Adopted on 16 April 1992)*). A Certificate or Statement of Compliance issued by LR or a competent Authority recognised by LR is to be provided. As an alternative, a self-contained Vapour Recovery System, which is of a type approved by LR and which achieves equivalent performance to the systems above, may be fitted.

■ Section 3 Supplementary characters

3.1 Hull anti-fouling systems – A character

3.1.1 For assignment of the **A** character, the anti-fouling system applied to the ship's hull is to be listed as biocide-free in the Lloyd's Register List of Approved Products.

3.2 Bio-fouling – BIO character

3.2.1 For the assignment of the BIO character, the ship is to have in place bio-fouling management plans, developed in accordance with IMO *Resolution MEPC.207(62) – 2011 Guidelines for the Control and Management of Ships' Biofouling to minimize the transfer of invasive Aquatic Species – (Adopted on 15 July 2011)*. In addition, the Bio-fouling Management Plan is to be reviewed by LR for conformance with *Resolution MEPC.207(62) – 2011 Guidelines for the Control and Management of Ships' Biofouling to minimize the transfer of invasive Aquatic Species – (Adopted on 15 July 2011)*.

3.2.2 The ship is also to have on board a Bio-fouling Record Book in the format shown in *Appendix 2 - Biofouling Management Plan and Record book of Resolution MEPC.207(62) – 2011 Guidelines for the Control and Management of Ships' Biofouling to minimize the transfer of invasive Aquatic Species – (Adopted on 15 July 2011)* that contains at least the following:

- Details of the anti-fouling systems and operational practices used (where appropriate, as recorded in the Anti-fouling System Certificate), where and when it was installed, areas of the ship that are coated, its maintenance and, where applicable, its operation; dates and location of dry-dockings/slippings, including the date the ship was refloat, and any measures taken to remove bio-fouling or to renew or repair the anti-fouling system;
- The date and location of in-water inspections, the results of those inspections and any corrective action taken to deal with observed bio-fouling;
- The dates and details of inspection and maintenance of internal sea-water cooling systems, the results of those inspections, and any corrective action taken to deal with observed bio-fouling and any reported blockages; and
- Details of when the ship has been operating outside its normal operating profile, including any details of when the ship was laid-up or inactive for extended periods of time.

3.3 Ballast water treatment – BWT characters

3.3.1 Where a ballast water treatment system is installed, the character **BWT** will be assigned, provided that the treatment system is installed, utilised and approved in accordance with *Resolution MEPC.174(58) – Guidelines for Approval of Ballast Water Management Systems (G8) – (Adopted on 10 October 2008)* or *Resolution MEPC.125(53) - Guidelines for Approval of Ballast Water Management Systems (G8) - (Adopted on 22 July 2005)*.

3.3.2 As an alternative to a system approved in accordance with *Resolution MEPC.174(58) – Guidelines for Approval of Ballast Water Management Systems (G8) – (Adopted on 10 October 2008)* or *Resolution MEPC.125(53) - Guidelines for Approval of Ballast Water Management Systems (G8) - (Adopted on 22 July 2005)*, a system meeting the requirements of *Regulation D-4 - Prototype Ballast Water Treatment Technologies Prototype Ballast Water Treatment Technologies* of the BWM Convention will be accepted.

3.3.3 A ballast water record book for the purpose of recording all ballast water operations and use of the treatment system is to be available on board and maintained.

3.3.4 New ships are to take account of the guidance on design and construction to facilitate sediment control within IMO Resolutions *Resolution MEPC.150(55) - Guidelines on Design and Construction to Facilitate Sediment Control on Ships (G12) - (Adopted on 13 October 2006)* and *Resolution MEPC.206(62) – Procedure for Approving Other Methods of Ballast Water Management in Accordance with Regulation B-3.7 of the BWM Convention – (Adopted on 15 July 2011)*, as far as is practicable.

3.4 Cargo residue minimisation – CRM character

3.4.1 For assignment of the **CRM** character, cargo residue is to be minimised.

3.4.2 In accordance with MARPOL Annex II, *Regulation 12 - Pumping, piping, unloading arrangements and slop tanks*, individual cargo tanks are not to retain more than 60 litres of residue in the tank and associated piping.

Arrangements and Equipment for Environmental Protection (ECO Class Notation)

Part 7, Chapter 11

Section 3

3.4.3 A performance test is to be conducted in accordance with *Appendix 5 - Assessment of Residue Quantities in Cargo Tanks, Pumps and Associated Piping* of MARPOL Annex II and a record of the test results retained on board.

3.5 Environmentally Acceptable Lubricants - EAL character

3.5.1 For assignment of the **EAL** character, the ship shall use Environmentally Acceptable Lubricants (EAL) that comply with the EPA criteria, as defined in Section 2.2.9 of the 2013 Vessel General Permit (VGP).

3.5.2 Ships shall have on board a 'Report of Environmentally Acceptable Lubricants' and a Statement of Fact issued by LR or equivalent documentation issued by another IACS member.

3.5.3 All the planned actions mentioned in the relevant Sections of the Report shall be completed, as appropriate, for the assignment of the supplementary character.

3.6 Energy Efficiency Design Index – EEDI-1, EEDI-2, EEDI-3 characters

3.6.1 For assignment of the EAL character, the ship shall use Environmentally Acceptable Lubricants (EAL)

3.6.2 The 'attained' Energy Efficiency Design Index is to be established in accordance with the 2012 Guidelines on the method of calculation of attained EEDI for new ships (*Resolution MEPC.203(62) – Amendments to the Annex of the Protocol of 1997 to Amend the International Convention for the Prevention of Pollution from Ships...*) and verified in accordance with LR's procedure for verifying EEDI values.

3.6.3 The **EEDI-1** character will be assigned to 'new ships' (according to MARPOL Annex VI, Chapter 1, *Regulation 2 Definitions*) to which EEDI Phase 0 is applicable when the 'attained' EEDI is less than or equal to the EEDI Phase 1 requirement.

3.6.4 The **EEDI-2** character will be assigned to 'new ships' (according to MARPOL Annex VI, Chapter 1, *Regulation 2 Definitions*) to which EEDI Phase 0 or Phase 1 is applicable when the 'attained' EEDI is less than or equal to the EEDI Phase 2 requirement.

3.6.5 The **EEDI-3** character will be assigned to 'new ships' (according to MARPOL Annex VI, Chapter 1, *Regulation 2 Definitions*) to which EEDI Phase 0, Phase 1 or Phase 2 is applicable when the 'attained' EEDI is less than or equal to the EEDI Phase 3 requirement.

3.7 Energy management – SEEMP and EnMS characters

3.7.1 For assignment of the **SEEMP** character, and in addition to the requirements specified in *Pt 7, Ch 11, 2.4 Energy management*, a SEEMP is to be reviewed by LR to check that it is in alignment with the IMO *Resolution MEPC.213(63) – 2012 Guidelines for the Development of a Ship Energy Efficiency Management Plan (SEEMP) – (Adopted on 2 March 2012)* and reflects industry guidelines as applicable. This is to be demonstrated by the LR SEEMP Statement of Conformance and associated documentation.

3.7.2 For the assignment of the **EnMS** character, certification under ISO 50001 (Energy Management) is to be issued by an accredited organisation and is to be applicable to the management and operation of the ship.

3.8 Integrated bilge water treatment system – IBTS character

3.8.1 These requirements apply to ships with an integrated bilge water system.

3.8.2 For assignment of the **IBTS** character, the ship is to have an integrated bilge water system designed and installed to meet the requirements of the *Revised Guidelines for Systems for Handling Oily Wastes in Machinery Spaces of Ships* and incorporating *MEPC.1/Circular.642 – 2008 Revised Guidelines for Systems for Handling Oily Wastes in Machinery Spaces of Ships Incorporating Guidance Notes for an Integrated Bilge Water Treatment System (IBTS)...* & *MEPC.1/Circular.643 – Harmonized Implementation of the Revised Guidelines and Specifications for Pollution Prevention Equipment for Machinery Space Bilges of Ships During the Type-Approval Process – (12 November 2008)* as amended by *MEPC.1/Circular.676 – Amendment to the 2008 Revised Guidelines for Systems for Handling Oily Wastes in Machinery Spaces of Ships Incorporating Guidance Notes for an Integrated Bilge Water Treatment System (IBTS) – (31 July 2009)* & *MEPC.1/Circular.760 – Amendments to the 2008 Revised Guidelines for Systems for Handling Oily Wastes in Machinery Spaces of Ships Incorporating Guidance Notes for an IBTS (MEPC.1/Circ.642, as Amended by MEPC.1/Circ.676) – (25 August 2011)*.

3.8.3 Ships are to have on board a Statement of Fact on Installation of an Integrated Bilge Water Treatment System (IBTS), issued by LR.

Arrangements and Equipment for Environmental Protection (ECO Class Notation)

Part 7, Chapter 11

Section 3

3.9 Grey water – GW character

3.9.1 For assignment of the **GW** character a dedicated plant for the treatment of grey water is to be installed, and the plant discharge effluent is to meet the standards specified in *Pt 7, Ch 11, 3.9 Grey water – GW character 3.9.2* or *Pt 7, Ch 11, 3.9 Grey water – GW character 3.9.3*, as applicable. The **GW** character will also be assigned where grey water is retained on board in dedicated holding tank(s) for discharge ashore, subject to the requirements specified in *Pt 7, Ch 11, 3.9 Grey water – GW character 3.9.4* to *Pt 7, Ch 11, 3.9 Grey water – GW character 3.9.9* being met.

3.9.2 Where it is not intended that the effluent is recycled or re-used for any purpose, the effluent of the grey water treatment plant is to meet the following standards:

(a) Thermotolerant coliforms:

The geometric mean of the thermotolerant coliform count of samples of effluent taken during a test period is not to exceed 100 thermotolerant coliforms/100 ml as determined by membrane filter, multiple tube fermentation or an equivalent analytical procedure.

(b) Total Suspended solids:

- Where the equipment is tested onshore, the geometric mean of the total suspended solids content of the samples of effluent taken during the test period is not to exceed 35 mg/l.
- Where the equipment is tested on board the ship, the geometric mean of the total suspended solids content of the samples of effluent taken during the test period is not to exceed the suspended solids content of the ambient (flushing) water used on board plus 35 mg/l.
- The method of testing is to be as given in *Resolution MEPC.159(55) - Revised Guidelines on Implementation of Effluent Standards and Performance Tests for Sewage Treatment Plants - (Adopted on 13 October 2006)*.

(c) Biochemical Oxygen Demand (BOD₅) and chemical oxygen demand (COD):

- The geometric mean of a 5-day Biochemical Oxygen Demand (BOD₅) is not to exceed 25 mg/l. The chemical oxygen demand (COD) is not to exceed 125 mg/l. Test methods are to be ISO 15705:2002 for COD and ISO 5815-1:2003 for carbonaceous BOD₅ or other internationally accepted equivalent test standards.

(d) pH: The pH of the samples of effluent taken during the test period is to be between 6 and 8,5.

(e) Zero or non-detected values: For thermotolerant coliforms, zero values are to be replaced with a value of 1 thermotolerant coliform/100 ml to allow the calculation of the geometric mean. For total suspended solids, BOD₅ and COD values below the limit of detection are to be replaced with one half the limit of detection to allow the calculation of the geometric mean.

3.9.3 Where it is intended that the effluent of the grey water treatment plant is to be re-used or recycled for any purpose, the effluent is to meet the potable water quality standards of the Flag or Port State Administration, as appropriate.

3.9.4 As an alternative to treatment, where grey water is retained on board in dedicated holding tank(s) for discharge ashore an additional allowance of 135 litres per person per day is to be made in the capacity of the holding tanks. Each tank is to be fitted with a means to open the tank, means to verify visually the contents of the tank and a high level alarm. Each tank is to be fitted with a means to open the tank, means to verify visually the contents of the tank and a high level alarm. See *Pt 7, Ch 11, 2.10 Sewage treatment 2.10.2*.

3.9.5 Where grey water is retained on board in dedicated holding tanks, means are to be provided to aerate the tanks to prevent the development of anaerobic conditions, taking into account *MSC/Circular.648 – Guidelines for the Operation, Inspection and Maintenance of Ship Sewage Systems – (Adopted on 6 June 1994)*.

3.9.6 Ventilation pipes from the grey water treatment system and, where provided, from holding tank(s) are to be independent of other ventilation systems.

3.9.7 A suitable piping system from the grey water treatment system or holding tank(s) is to be provided to allow discharge to shore reception facilities. The discharge pipe is to terminate with a standard discharge connection complying with the requirements of MARPOL Annex IV, *Regulation 10 - Standard Discharge Connections*. Any connection from the grey water system to the sewage discharge is to be via a screw down non-return valve.

3.9.8 Records of grey water treatment and/or discharge are to be maintained. A single record book may be utilised for both grey water and sewage records. Records detailing discharges from the holding tank(s) are to include:

- (a) the date, location and quantity of grey water discharged from the holding tank(s) either ashore or at sea;
- (b) rate of discharge of untreated grey water;
- (c) distance from land and ship's speed, when untreated grey water is discharged to sea.

3.9.9 Procedures for the cleaning and safe entry of grey water treatment systems and holding tanks, including the use of suitable personal protective equipment, are to be provided and implemented.

3.10 Inventory of hazardous materials – IHM character

3.10.1 For assignment of the **IHM** character, the ship is to possess an inventory of hazardous materials in compliance with Regulation 5 of the *Hong Kong International Convention for the Safe and Environmentally Sound Recycling of Ships*.

3.10.2 The inventory is to be independently verified by LR.

3.10.3 Procedures covering maintenance of the inventory of hazardous materials throughout the ship's life are to be established and implemented. The procedures are to address, *inter alia*, new installations containing hazardous materials specified in appendices 1 and 2 of the *Hong Kong International Convention for the Safe and Environmentally Sound Recycling of Ships* and relevant changes in the ship's structure and equipment.

3.11 Nitrogen oxides **NO_{-x1}**, **NO_{-x2}**, **NO_{-x3}** characters

3.11.1 For assignment of the **NO_{-x1}** or **NO_{-x2}** character, the total weighted value of NO_x emissions from all installed diesel engines defined within *Pt 7, Ch 11, 2.2 Nitrogen oxides (NOx) 2.2.1* is not to exceed 80 per cent of the total weighted NO_x emission limits specified in MARPOL Annex VI, *Regulation 13 – Nitrogen Oxides (NOx)*.

3.11.2 The total weighted emission value for the ship (*WV*) is to be calculated as follows:

$$WV_{[ship]} = \frac{WAEV_{[cert]}}{WAEV_{[IMO]}}$$

where

$$WAEV_{[cert]} = \frac{\sum_{n=1}^n (NO_{x[cert]} \cdot P)}{\sum_{n=1}^n (P)}$$

$$WAEV_{[IMO]} = \frac{\sum_{n=1}^n (NO_{x[IMO]} \cdot P)}{\sum_{n=1}^n (P)}$$

n = the number of individual engines on board the ship

P = the rated power in kW, of each individual installed engine

NO_{x[cert]} = the certified NO_x emission value, in g/kWh, for each individual engine

NO_{x[IMO]} = the NO_x emission limit value, in g/kWh, of each individual engine, in g/kWh, applicable at the date of construction of the ship, or installation date of the engine, as applicable, as specified in *Regulation 13 – Nitrogen Oxides (NOx)* of Annex VI to MARPOL.

3.11.3 For ships constructed before 1 January 2011, the **NO_{-x1}** character will be assigned when:

$$\frac{WAEV_{[cert]}}{WAEV_{[IMO]}} \leq 0,80$$

For ships constructed on or after 1 January 2011, the **NO_{-x2}** character will be assigned when:

$$\frac{WAEV_{[cert]}}{WAEV_{[IMO]}} \leq 0,80$$

3.11.4 For assignment of the **NO_{-x3}** character, engines, as defined in *Pt 7, Ch 11, 2.2 Nitrogen oxides (NOx) 2.2.1*, and any associated NO_x emission abatement systems are to be certified as meeting the Tier 3 NO_x emission limits specified in MARPOL Annex VI, *Regulation 13 – Nitrogen Oxides (NOx)*.

3.11.5 Equipment and systems used to control NO_x emission levels are to:

- be arranged so that failure will not prevent continued safe operation of the engine;
- be operated in accordance with manufacturer's instructions;
- be designed, constructed and installed to ensure structure integrity and freedom from significant vibration;
- be designed to include adequate hatches for inspection and maintenance purposes; and

Arrangements and Equipment for Environmental Protection (ECO Class Notation)

(e) be instrumented to record operation. Records of operation and the degree of control are to be maintained.

Alternative control arrangements will be given special consideration.

3.11.6 Procedures covering the use and maintenance of the equipment and systems used to control NO_x are to be established and implemented. Records are to be maintained which demonstrate the operation of the equipment and systems and the resultant level of NO_x emissions to the atmosphere.

3.11.7 Where engines constructed before 1 January 2000 are not certified in accordance with MARPOL Annex VI - *Regulations for the Prevention of Air Pollution from Ships*, the test procedure and measurement method are to be in accordance with either the Simplified Measurement Method or Direct Measurement and Monitoring Method given in Chapter 6 of the IMO *NO_x Technical Code (2008) - Technical Code on Control of Emission of Nitrogen Oxides from Marine Diesel Engines*.

3.11.8 Where engines are constructed on or after 1 January 2000, the NO_x emission value is to be established in accordance with the *NO_x Technical Code - Technical Code on Control of Emission of Nitrogen Oxides from Marine Diesel Engines*.

3.11.9 In the case where the individual engines are 'family' or 'group' engines, as defined in the NO_x Technical Code, the respective certified emission value is to be taken as that of the relevant Parent Engine.

3.12 Oily bilge water – OW character

3.12.1 For assignment of the **OW** character, all drainage from machinery space bilges is to be discharged ashore, except under exceptional circumstances.

3.12.2 Adequate capacity for storage of oily bilge water between discharges ashore is to be provided.

3.12.3 Alternatively, discharge to sea is permitted where it can be demonstrated that the oil-in-water content of the water discharged is less than 5 ppm.

3.12.4 The bilge alarm, set at 5 ppm, is to be recalibrated or retested every five years by the manufacturer or other acceptable alternative and full records of the recalibration or retesting are to be kept on board.

3.12.5 Full records of all discharges are to be kept.

3.13 Protected oil tanks – P character

3.13.1 For assignment of the **P** character, in addition to compliance with the requirements of *Pt 7, Ch 11, 2.7 Oil pollution prevention 2.7.11*, all fuel oil, lubricating oil tanks and hydraulic oil are to be located in a protected location away from the ship's side or bottom shell plating.

3.13.2 Fuel oil, lubricating oil and hydraulic oil tanks are to be located in accordance with the requirements relating to fuel oil tank protection given in MARPOL Annex I, *Regulation 12A – Oil fuel tank protection*, paragraphs 6, 7 and 8. The performance standard specified in paragraph 11 of *Regulation 12A – Oil fuel tank protection* will not be accepted.

3.13.3 Main engine lubricating oil drain tanks and fuel overflow tanks are excluded.

3.13.4 Arrangements providing equivalent protection will be given special consideration.

3.13.5 Suction wells may protrude below fuel oil tanks provided they are as small as possible and the distance between the tank bottom and the ship's bottom shell plating is not reduced by more than 50 per cent.

3.14 Refrigeration systems – R character

3.14.1 For assignment of the **R** character, natural substances are to be used as the refrigerants in all main refrigeration systems such as cargo systems, provision rooms and air conditioning.

3.14.2 Small factory-built refrigeration system(s) that use fluorinated refrigerants, having a Global Warming Potential (GWP) of less than 1950 are allowable.

3.14.3 The GWP value is based on the 100-year time horizon.

3.15 Sulphur oxides – DIST and SO_x characters

3.15.1 For assignment of the **DIST** character, ships must meet the requirements of LR's Descriptive Note **DIST(M, AB, I, IG)**, as applicable.

3.15.2 For assignment of the **SO_x** character, all fuel used on board is to be:

Arrangements and Equipment for Environmental Protection (ECO Class Notation)

Part 7, Chapter 11 Section 3

- (a) distillate with a sulphur content not exceeding 0,10 per cent m/m; or
- (b) an alternative fuel or a hybrid fuel management solution which has a resulting sulphur content which is not to exceed 0,10 per cent m/m.

3.15.3 The sampling, fuel sulphur analysis methods and verification requirements stipulated in *Pt 7, Ch 11, 2.3 Sulphur oxides (SO_x) 2.3.4* and *Pt 7, Ch 11, 2.3 Sulphur oxides (SO_x) 2.3.5* are to be complied with.

3.15.4 Alternative arrangements providing an equivalent level of environmental protection will be considered for the assignment of the **SO_x** character. If an Exhaust Gas Cleaning System is fitted, it is to be certified to *Resolution MEPC.184(59) – 2009 Guidelines for Exhaust Gas Cleaning Systems – (adopted on 17 July 2009)*.

3.16 Enhanced tank cleaning – TC character

3.16.1 For the assignment of the **TC** character, oil and chemical tankers are to be provided with tank washing equipment meeting the standards specified in *Pt 7, Ch 11, 3.16 Enhanced tank cleaning – TC character 3.16.2* to *Pt 7, Ch 11, 3.16 Enhanced tank cleaning – TC character 3.16.8*.

3.16.2 Cargo tanks are to be served by individual pumps.

3.16.3 Permanent tank washing machines shall be type approved in accordance with the revised *IMO Resolution A.446(XI) – Revised specifications for the design, operation and control of crude oil washing systems – (Adopted on 15 November 1979)*, and their method of support is to be acceptable to LR.

3.16.4 At the design stage the following minimum procedures are to be used to determine the area of the tank surface covered by direct impingement (longitudinals, brackets, stiffeners, ladders, pipework, corrugations on corrugated bulkheads and face plates can be ignored):

- (a) using suitable structural plans, lines are set out from the tips of each machine to those parts of the tank within the range of the jets; or
- (b) a pinpoint of light simulating the tip of the tank washing machine in a scale model of the tank are to be used.

Alternative methods of measurement will be considered.

3.16.5 Additional tank washing equipment, which may be portable, is also to be provided to enable washing of the shadow areas without the necessity to enter the tanks. The use of portable machines to wash the shadow areas is not to be undertaken where the last cargo in the tank has toxic or low ignition properties, reacts with water or has other properties specified in chapter 15 of the *IBC Code - International Code for the Construction and Equipment of Ships Carrying Dangerous Chemicals in Bulk Amended by Resolution MEPC.225(64)* which would prevent water washing or opening of the tank to allow the use of portable washing machines.

3.16.6 A back-up system to provide cleaning capability in the event of failure of one tank washing machine is to be provided.

3.16.7 Heating equipment is to be provided for a tank washing medium which achieves a minimum temperature of 85°C at the connection to the tank washing machine.

3.16.8 The effectiveness of the tank washing system is to be confirmed by tank inspections or other means as required by LR. The confirmation is to be carried out when the ship is in service. For ships fitted with crude oil washing system(s) the confirmation will be carried out as part of the *MARPOL Annex I of MARPOL 73/78 Regulations for the Prevention of Pollution by Oil* survey and need not be carried out separately.

3.17 Vapour emission control systems – VECS-L, VOC-R characters

3.17.1 Tankers carrying crude oil, petroleum products or chemicals having a flash point not exceeding 60°C (closed-cup test) will be assigned the **VECS-L, VOC-R** character(s) provided the requirements of *Pt 7, Ch 11, 3.17 Vapour emission control systems – VECS-L, VOC-R characters 3.17.2* and/or *Pt 7, Ch 11, 3.17 Vapour emission control systems – VECS-L, VOC-R characters 3.17.3* respectively are complied with, as applicable.

3.17.2 For assignment of the **VECS-L** character, a vapour emission control system is to be fitted, which, in addition to *Pt 7, Ch 11, 3.16 Enhanced tank cleaning – TC character 3.16.2*, has been designed and constructed to meet the requirements for vapour balancing in accordance with USCG 46, CFR 39.40 for service vessels.

3.17.3 For assignment of the **VOC-R** character, a self-contained system capable of preventing vapour emission formation during loading is to be fitted. This vapour emission prevention system is to be of a type approved by LR and is to reduce vapour emission formation by at least 75 per cent (v/v) as compared to an equivalent ship to which no vapour emissions prevention system has been fitted.

■ Section 4 Survey requirements

4.1 Initial Survey and Audit

4.1.1 Following satisfactory review of the plans and other information submitted (see *Pt 7, Ch 11, 1.5 Information to be submitted*), an **ECO** Initial Survey is to be undertaken for ships under construction or in service.

4.1.2 At the **ECO** Initial Survey, the Surveyor is to be satisfied that the requirements of these Rules, including those relating to any requested supplementary characters, are complied with. The Surveyor is to verify that the hull and machinery arrangements are in accordance with the approved documentation. The installed equipment, together with associated control and alarm systems, is to be demonstrated under working conditions.

4.1.3 Following the successful completion of the Initial Survey, the **ECO** notation may be assigned to a ship. The **ECO** notation will be valid, in the first instance until the first **ECO** Annual Survey. At the first Annual Survey, an audit of the operational procedures as required by these Rules is to be undertaken. Prior to the LR audit, the operational procedures must have been fully implemented and audited by the Operator and the applicable record books must contain in-service records for a period of at least 3 months.

4.1.4 Audits are to confirm by direct observation, examination of internal audit reports and scrutiny of records that each of the procedures has been implemented over the preceding period. It is also to be verified that:

- (a) the required resources and equipment have been provided; and
- (b) the ship's staff are aware of their duties and responsibilities, and can perform the assigned tasks.

4.2 Periodical Surveys and Audits

4.2.1 **ECO** Annual Surveys and Audits are to be held on all ships to which the **ECO** notation applies within three months of each anniversary for assignment of the full **ECO** notation.

4.2.2 At the **ECO** Annual Survey and Audit, the Surveyor is to be satisfied that the arrangements and equipment comply with these Rules and operating procedures have been implemented. As far as possible, the installed equipment, together with associated control and alarm systems, are to be demonstrated under working conditions. Additionally:

- (a) where changes to arrangements or equipment fitted to meet the requirements of these Rules have been made, it is to be verified that these changes are in accordance with approved documentation; and
- (b) records for the preceding 12 months are to be reviewed.

4.2.3 **ECO** Audits are to be undertaken in accordance with the requirements given in *Pt 7, Ch 11, 4.1 Initial Survey and Audit 4.1.4*.

4.2.4 Where the periodical surveys and audits are not completed in accordance with *Pt 7, Ch 11, 4.2 Periodical Surveys and Audits 4.2.1*, the **ECO** Notation will be suspended. Re-instatement will be subject to surveys being held appropriate to the age of the ship and the circumstances of the case.

4.2.5 Where the periodical surveys and audits identify non-conformances, the **ECO** notation will be suspended. Re-instatement will be as directed by the Classification Committee, appropriate to the circumstances of the case.

4.3 Change of company

4.3.1 Where the company (as defined in the ISM Code) changes, the **ECO** notation will be suspended.

4.3.2 The new company may adopt the previously approved procedures as required by these Rules or may compile new procedures.

4.3.3 Following implementation of the approved procedures, an audit, in accordance with the requirements in *Pt 7, Ch 11, 4.1 Initial Survey and Audit 4.1.3* and *Pt 7, Ch 11, 4.1 Initial Survey and Audit 4.1.4*, is to be undertaken.

4.3.4 The **ECO** notation will be re-assigned following successful completion of the audit provided that the ship has a valid Safety Management Certificate (SMC) and the general requirements given in *Pt 7, Ch 11, 2.1 General 2.1.1* are complied with.

Section

- 1 **General requirements**
- 2 **Noise**
- 3 **Vibration**
- 4 **Testing**
- 5 **Noise and vibration survey reporting**
- 6 **Non-periodical survey requirements**
- 7 **Referenced Standards**

■ Section 1 General requirements

1.1 Scope

1.1.1 These Rules set down the criteria for the assessment of the noise and vibration on ships and are applied in addition to the other relevant requirements of the *Rules and Regulations for the Classification of Ships* (hereinafter referred to as the Rules for Ships).

1.1.2 The requirements of this chapter may be applied where no other statutory requirements exist.

1.1.3 These Rules provide for two alternatives:

- (a) **Class Notations** which indicate that the ship has been assessed and complies with noise and vibration criteria in these Rules and that a periodic survey regime has been established for the lifetime of the ship.
- (b) **Certificate of Compliance** which provides evidence that the ship has been assessed and found to comply with the noise and vibration criteria in these Rules.

1.1.4 Spaces that comply with the noise level limits specified in *Table 12.2.4 Crew work areas - maximum noise levels in dB(A)* and under Acceptance Numeral 3 in *Table 12.2.1 Passenger ships - Maximum noise levels in dB(A)* and *Table 12.2.3 Crew accommodation - Maximum noise levels in dB(A)*, will meet the requirements of section 4 of IMO Resolution MSC.337(91) – *Adoption of the Code on Noise Levels on Board Ships – (Adopted on 30 November 2012)*The Annex below is consolidated into *Noise Levels - Code on Noise Levels on Board Ships (Resolution MSC.337(91))*, when measured in accordance with the requirements of Chapters 2 and 3 of that Resolution.

1.1.5 Spaces that comply with the noise level limits specified under Acceptance Numerals 1 and 2 in *Table 12.2.1 Passenger ships - Maximum noise levels in dB(A)* and *Table 12.2.3 Crew accommodation - Maximum noise levels in dB(A)*, will achieve enhanced levels of passenger and crew comfort as applicable, when measured in accordance with the requirements of Chapters 2 and 3 of IMO Resolution MSC.337(91) – *Adoption of the Code on Noise Levels on Board Ships – (Adopted on 30 November 2012)*The Annex below is consolidated into *Noise Levels - Code on Noise Levels on Board Ships (Resolution MSC.337(91))*. All vessels can apply for Acceptance Numerals 1 and 2.

1.1.6 These Rules recognise existing National and International Standards and specify levels of noise and vibration currently achievable using good engineering practice. Compliance with these requirements will be assessed by review of procedures, inspection and measurement of the relevant parameters and pre-survey reviews. Inspections and measurements are to be conducted, witnessed or assessed by LR's Surveyors unless otherwise agreed by Lloyd's Register (hereinafter referred to as LR).

1.1.7 Accommodation comfort is a function of ship type and layout. These Rules address two types of ship:

- (a) Passenger (e.g. cruise ships, ro-ro ferries).
- (b) Cargo (e.g. container ships, tankers).

1.1.8 These Rules include levels of noise and vibration which should be verified by measurements following completion of the ship. It is recommended that the Builders undertake calculations of noise and vibration characteristics so that any potential problem areas can be identified and control measures implemented.

Passenger and Crew Accommodation comfort Part 7, Chapter 12

Section 1

1.1.9 The sound pressure levels for audible alarms and public address systems fitted in accordance with other sections of the Rules are to satisfy *IMO Resolution A.1021(26) – Code on Alerts and Indicators, 2009 – (Adopted on 2 December 2009)*.

1.2 Definitions

1.2.1 **Passenger spaces** are defined as all areas intended for passenger use, and include the following:

- (a) Passenger cabins.
- (b) Public spaces (e.g. restaurants, hospital, lounges, reading and games rooms, gymnasiums, corridors, shops).
- (c) Open deck recreation areas.

1.2.2 **Crew spaces** are defined as all areas intended for crew use only, and include the following:

- (a) Accommodation spaces (e.g. cabins, offices, mess rooms, recreation rooms).
- (b) Work spaces.
- (c) Navigation spaces.

1.2.3 **Noise level** is defined as the A-weighted sound pressure level measured in accordance with ISO 2923.

1.2.4 **Vibration level** is defined by the application of ISO 6954:2000

The vibration level is defined as the overall frequency weighted r.m.s. value of vibration during a period of steady-state operation over the frequency range 1 to 80 Hz.

1.3 Class notations

1.3.1 The class notations described in *Pt 7, Ch 12, 1.3 Class notations 1.3.2 to Pt 7, Ch 12, 1.3 Class notations 1.3.6* provide standards for noise and vibration levels in different spaces at the time of delivery and during the ship's life if substantial changes to the machinery installation or interior arrangements are made.

1.3.2 The **PAC** (Passenger Accommodation Comfort), **CAC** (Crew Accommodation Comfort) and **PCAC** (Passenger and Crew Accommodation Comfort) notations are optional and are primarily intended to apply to passenger ship's. If requested, however, any ship can be assessed for compliance, using these requirements as the basis for the assessment and a LR Certificate of Compliance issued (see *Pt 7, Ch 12, 1.1 Scope 1.1.3* and *Pt 7, Ch 12, 1.4 Certificate of Compliance*).

1.3.3 The **PAC** notation indicates that the passenger accommodation meets the acceptance criteria whilst the **CAC** notation indicates that the crew accommodation and work areas meet the acceptance criteria. The **PCAC** notation indicates that the passenger and crew spaces both meet the acceptance criteria.

1.3.4 For ships which achieve the noise and vibration comfort standards specified in these Rules, the notation **PAC**, **CAC** or **PCAC** will be assigned.

1.3.5 Following the **PAC** or **CAC** notation, numerals **1**, **2** or **3** will indicate the acceptance criteria to which the noise and vibration levels have been assessed. In the case of the **PCAC** notation, two numerals will be assigned. The first will indicate the acceptance criteria for passenger accommodation, whilst the second will indicate the crew comfort criteria.

1.3.6 For particular vessels, impact insulation and transient noise in accordance with *Pt 7, Ch 12, 2.5 Impact insulation* and *Pt 7, Ch 12, 2.6 Transient noise* together with any additional or more stringent noise and vibration criteria may be assessed within the scope of the notations where agreed between the Owner, Builder and LR.

1.4 Certificate of Compliance

1.4.1 A Certificate of Compliance records that a ship has been designed and constructed to satisfy the noise and vibration criteria contained in these Rules. This is to be confirmed by measurements and reporting in accordance with Sections *Pt 7, Ch 12, 4 Testing* and *Pt 7, Ch 12, 5 Noise and vibration survey reporting*.

1.4.2 A Certificate of Compliance is optional and if requested, any ship can be assessed for compliance using the Rule requirements as basis for assessment.

1.4.3 Where noise and vibration levels are at variance with those prescribed by these Rules, these will be added to the certificate for information purposes.

1.4.4 A Certificate of Compliance will be issued after the initial survey required by *Pt 7, Ch 12, 6 Non-periodical survey requirements*.

Passenger and Crew Accommodation comfort Part 7, Chapter 12

Section 2

■ Section 2 Noise

2.1 Assessment criteria

2.1.1 Where a space is occupied by both passengers and crew, the more stringent of the relevant requirements apply unless agreed between the Builder and Owner and advised to LR.

2.2 Passenger accommodation and public spaces

2.2.1 Under test conditions specified in *Pt 7, Ch 12, 4.2 Test conditions*, the applicable noise levels specified in *Table 12.2.1 Passenger ships - Maximum noise levels in dB(A)* should not generally be exceeded. See *Pt 7, Ch 12, 2.2 Passenger accommodation and public spaces 2.2.3*.

2.2.2 For cabins bordering discotheques and similar entertainment areas, the deck and bulkhead sound insulation is to be sufficient to ensure that the maximum cabin noise levels are not exceeded even when high external noise levels prevail.

Table 12.2.1 Passenger ships - Maximum noise levels in dB(A)

Location		Acceptance Numeral		
		1	2	3
Passenger cabins:	Standard Superior	49	52	55
		45	47	50
Public spaces:	Excluding shops	55	58	62
		60	62	65
Medical centre:		50	55	60
Theatre/auditorium		50	55	60
Open deck recreation areas (excluding swimming pools and similar)		67	72	72
Swimming pools and similar		70	75	75

Note 1. The levels may be exceeded by 5dB(A) within 3 m of a ventilation inlet/outlet or machinery intake/uptake on open decks.

Note 2. The levels may be exceeded by 3dB(A) in accommodation above the propellers for three decks above the mooring deck.

Note 3. The levels for open deck recreation areas refer to ship generated noise only. On open deck spaces the noise generated from the effects of wind and waves can be considered separately to limits agreed between the Builder and Owner and advised to LR for the trial conditions.

2.2.3 Acceptance of noise levels greater than those specified in *Table 12.2.1 Passenger ships - Maximum noise levels in dB(A)* may be considered where agreed between the Owner and Builder. Not more than 20 per cent of the passenger cabins, 30 per cent of the public spaces and 20 per cent of the crew cabins should exceed the relevant noise criteria by more than 3 dB(A).

2.2.4 Acoustic insulation of bulkheads and decks between passenger spaces is to be generally in accordance with the values of the weighted apparent sound reduction index R_w as given in *Table 12.2.2 Minimum air-borne sound insulation indices, R_w* , calculated using ISO 717/1. See also *Pt 7, Ch 12, 2.2 Passenger accommodation and public spaces 2.2.6*.

Table 12.2.2 Minimum air-borne sound insulation indices, R_w

Location	Acceptance Numeral		
	1	2	3

Passenger and Crew Accommodation comfort Part 7, Chapter 12

Passenger cabins:	Standard	40	38	37
	Superior	45	42	40
Cabin to corridor:	Standard	38	36	34
	Superior	42	40	37
Cabin to stairway:	Standard	47	45	43
	Superior	50	47	45
Cabin to public space (excluding corridors/ stairwells and discotheques):	Standard	52	48	48
	Superior	55	50	50
Discotheques to cabins		60	60	60
Discotheques to stairwells and public spaces		52	52	52
Cabin to machinery rooms and engine casing		55	53	50

2.2.5 For the purpose of selecting acoustic sound insulation, the following sound noise levels may be used with the agreement of the Owner and Builder:

- (a) Cabins – 80 dB(A).
- (b) Dining Rooms – 85 dB(A).
- (c) Corridors – 90 dB(A).
- (d) Discotheques, Theatres, Entertainment Areas – 105 dB(A).

2.2.6 Acceptance of bulkhead and deck acoustic insulation values less than those specified in *Table 12.2.2 Minimum airborne sound insulation indices*, R_w may be considered where agreed between the Owner and Builder. Not more than 20 per cent of the interfaces tested should have airborne sound insulation indices, R_w , more than 3 dB(A) lower than the minimum specified values.

2.3 Crew accommodation and work areas

2.3.1 Under the applicable test conditions specified in *Pt 7, Ch 12, 4.2 Test conditions*, the noise levels specified in *Table 12.2.3 Crew accommodation - Maximum noise levels in dB(A)* and *Table 12.2.4 Crew work areas - maximum noise levels in dB(A)* are not to be exceeded.

Table 12.2.3 Crew accommodation - Maximum noise levels in dB(A)

Location	Acceptance Numeral			
	1	2	3	
			Ships <10,000 grt	Ships ≥10,000 grt
Sleeping cabins, hospitals	50	53	60	55
Offices, conference rooms and day cabins	55	58	65	60
Mess rooms, lounges, reception areas and recreation rooms within accommodation	55	58	65	60
Recreational areas on open deck	67	72	75	75
Alleyways, changing rooms, bathrooms, lockers	70	75	75	75
NOTE				
The levels may be exceeded by 5 dB(A) within 3 m of a ventilation inlet/outlet or machinery intake/uptake on open decks.				

Table 12.2.4 Crew work areas - maximum noise levels in dB(A)

Location	dB(A) level
Machinery space(continuously manned) e.g. stores	90
Machinery space(not continuously manned) e.g. pump, refrigeration, thrusters or fan rooms	110
Workshops and non-specified work spaces	85
Machinery control rooms	75
Wheelhouse	65
Look-out posts e.g. at bridge wing or window	70
Additional limits:	
• 250 Hz band	68
• 500 Hz band	63
(measured according to IMO A.343(IX))	
Radio room	
Galleys and pantries:	75
• Equipment not working	75
• Individual items at 1 metre	80
Normally unoccupied spaces (e.g. holds, decks)	90
Ship's whistle, on bridge or forecastle	110

2.3.2 Crew space insulation is to comply with the requirements of IMO Resolution MSC.337(91) – Adoption of the Code on Noise Levels on Board Ships – (Adopted on 30 November 2012)The Annex below is consolidated into Noise Levels - Code on Noise Levels on Board Ships (Resolution MSC.337(91)).

2.4 Maximum noise levels

2.4.1 Where the measured noise level exceeds the specified criterion by 3 dB(A), or contains subjectively annoying low frequency or tonal components, the noise rating (NR) number is to be established in accordance with the graph shown in Figure 12.2.1 Noise rating curves. This is achieved by plotting the linear octave band levels on the graph; the NR number is that NR curve to which the highest plotted octave band level is anywhere tangent. The specified criterion may be considered satisfied if the NR number does not exceed the specified A-weighted value minus 5 dB(A).

Passenger and Crew Accommodation comfort Part 7, Chapter 12

Section 2

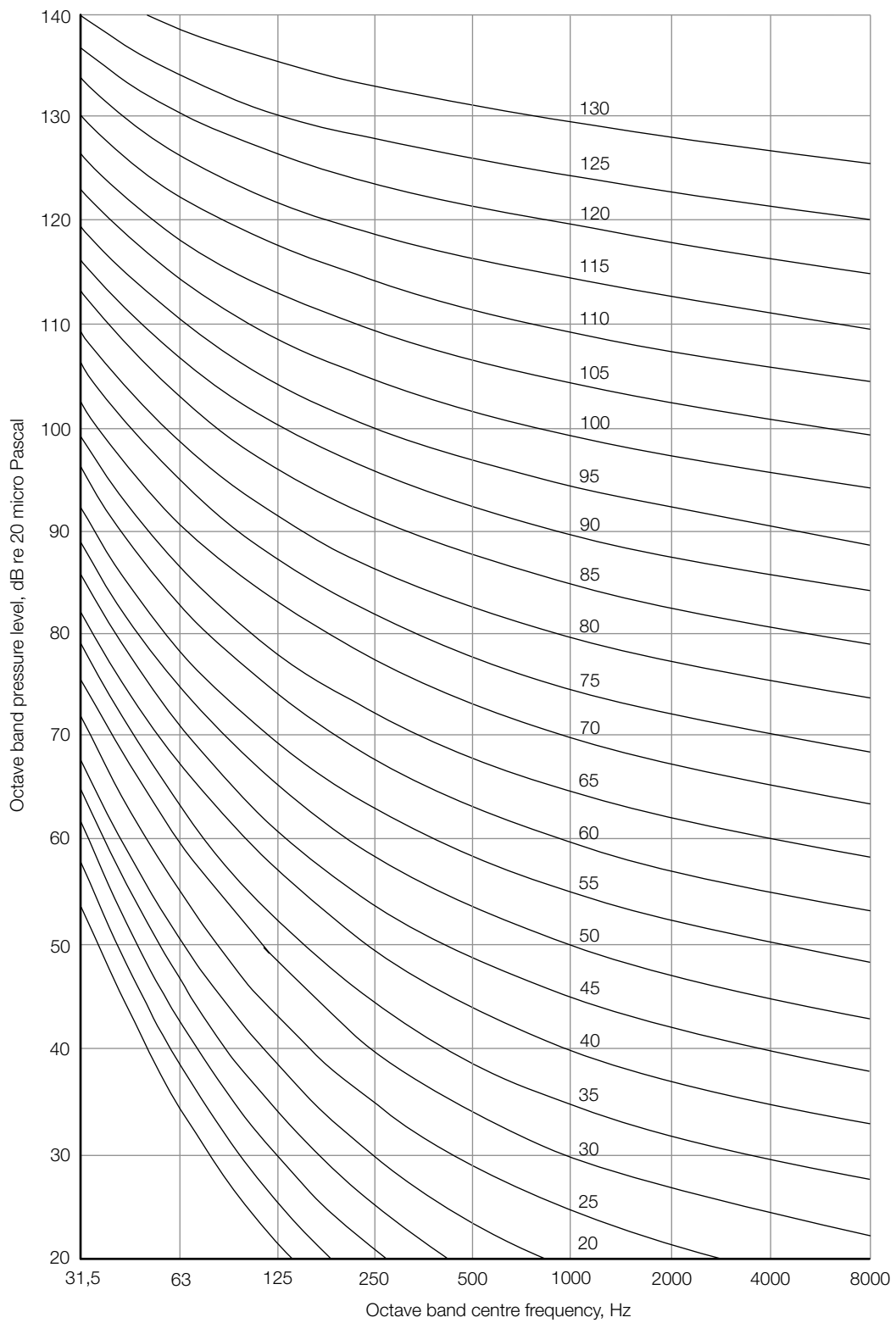

Figure 12.2.1 Noise rating curves

Passenger and Crew Accommodation comfort Part 7, Chapter 12

Section 2

2.4.2 Guidance on maximum acceptable sound pressure levels and noise exposure limits for crew spaces is given in IMO Resolution MSC.337(91) – Adoption of the Code on Noise Levels on Board Ships – (Adopted on 30 November 2012) The Annex below is consolidated into Noise Levels - Code on Noise Levels on Board Ships (Resolution MSC.337(91)).

2.5 Impact insulation

2.5.1 Where agreed between the Owner, Builder and LR, enhanced criteria for noise levels recognising the effects of impact sound pressures may be applied in accordance with Pt 7, Ch 12, 2.5 Impact insulation 2.5.2 to Pt 7, Ch 12, 2.5 Impact insulation 2.5.5.

2.5.2 For passenger and crew cabins located below or adjacent to dance floors, stages, aerobics and gymnasium areas, jogging tracks or other areas where impact noise is generated, the normalised impact sound pressure level measured within the cabins is not to exceed 45 dB.

2.5.3 For public rooms under dance floors, stages, aerobics and gymnasium areas, jogging tracks or other areas where impact noise is generated, the normalised impact sound pressure level within the space is not to exceed 55 dB.

2.5.4 For passenger cabins, the normalised impact sound pressure level, $L_{n,w}$, calculated using ISO 717/2, is to be generally in accordance with the values stated in Table 12.2.5 Passenger cabins normalised impact maximum sound pressure level $L_{n,w}$. See also Pt 7, Ch 12, 2.5 Impact insulation 2.5.5.

Table 12.2.5 Passenger cabins normalised impact maximum sound pressure level $L_{n,w}$

Location	dB
Below decks covered with carpet and soft materials	50
Below decks covered in hard materials (such as wood, marble or similar)	60
Below dance floors, theatre or sports rooms	45

2.5.5 Acceptance of normalised impact sound pressure levels greater than those specified in Table 12.2.5 Passenger cabins normalised impact maximum sound pressure level $L_{n,w}$ may be considered for assignment of the applicable class notation where agreed between the Owner, Builder and LR. No more than 20 per cent of the passenger cabins tested should exceed the levels specified by more than 3 dB.

2.6 Transient noise

2.6.1 Where agreed between the Owner, Builder and LR, enhanced criteria for transient noise levels may be applied in accordance with Pt 7, Ch 12, 2.6 Transient noise 2.6.2.

2.6.2 The maximum sound pressure level (L_{max}) emanating from any machinery or system caused by a single event that produces a noise ‘spike’ compared to the reference condition sound level (such as vacuum systems or valve operations) is not to cause an increase in noise in comparison with the reference condition as below:

- (a) Passenger cabins and public areas: +2 dB(A)
- (b) Officer cabins: +2 dB(A)
- (c) Crew cabins and public areas: +3 dB(A)

A tolerance of +1 dB(A) may be applied to 5 per cent of cabins and public areas in each fire zone on each deck. This criterion is generally applicable to the specified maximum noise levels for the space concerned.

■ **Section 3**
Vibration

3.1 Assessment criteria

3.1.1 Where a space is occupied by both passengers and crew, the more stringent of the relevant requirements apply unless agreed between the Builder and Owner and this agreement advised to LR.

3.1.2 The limits apply to vertical, fore and aft and athwartship vibrations which are to be assessed separately.

3.1.3 Under test conditions specified in *Pt 7, Ch 12, 4.2 Test conditions*, the applicable vibration levels specified in *Table 12.3.1 Passenger ship - Maximum vibration levels* and *Table 12.3.2 Crew spaces - Maximum vibration levels* should not be exceeded.

3.1.4 Acceptance of vibration levels greater than those specified in *Table 12.3.1 Passenger ship - Maximum vibration levels* and *Table 12.3.2 Crew spaces - Maximum vibration levels* may be considered for assignment of the applicable class notation where agreed between the Owner, Builder and LR.

Table 12.3.1 Passenger ship - Maximum vibration levels

Standard	ISO 6954:2000		
Units:	Peak velocity (1–80 Hz) velocity mm/s rms		
	Acceptance Numeral		
Location	1	2	3
Passenger cabin Luxury	1,5	1,8	2,1
Passenger cabin Standard	1,8	2,1	2,4
Public spaces	2,0	2,5	3,0
Open recreation decks	2,5	3,0	3,5
Note The vibration level may be exceeded by 0,3 mm/s in the ship's aft body directly above the propellers.			

Table 12.3.2 Crew spaces - Maximum vibration levels

Standard:	ISO 6954:2000
Units:	Frequency weighted (1–80 Hz) velocity mm/s rms
Location	
Accommodation and navigation spaces	3,5
Work spaces	5,0

3.2 Passenger accommodation and public spaces

3.2.1 Passenger spaces are to comply with the overall vibration levels specified in *Table 12.3.1 Passenger ship - Maximum vibration levels* and *Table 12.3.2 Crew spaces - Maximum vibration levels*.

3.2.2 No more than 20 per cent of all passenger spaces/areas and public spaces should exceed the relevant vibration criteria specified in *Table 12.3.1 Passenger ship - Maximum vibration levels* and *Table 12.3.2 Crew spaces - Maximum vibration levels* by more than 0,3 mm/s.

3.3 Crew accommodation and work spaces

3.3.1 Crew spaces are to comply with the overall vibration levels specified in *Table 12.3.2 Crew spaces - Maximum vibration levels*.

■ Section 4 Testing

4.1 Measurement procedures

4.1.1 These requirements take precedence where quoted standards may differ.

4.1.2 The trial measurements may be undertaken by an approved technical organisation as defined in *Pt 7, Ch 12, 4.7 Approved technical organisation* or by LR. In the former case, the measurements are to be witnessed by a LR Surveyor.

4.1.3 Subject to agreement by LR and the Owner/ Operator, the measurements may be undertaken by the Builder. In this case, the measurements are to be witnessed by a LR Surveyor.

4.2 Test conditions

4.2.1 Test conditions for the surveys are to be in accordance with those detailed in ISO 2923 and ISO 6954:2000 as applicable.

4.2.2 The intended operating and loading conditions of the ship during assessment surveys are to be submitted to LR for agreement, prior to commencement of surveys.

4.2.3 Surveys are to be conducted when the ship is fully outfitted and all systems contributing to noise and vibration levels are operational.

Note All systems operational are to include those systems that may operate simultaneously with others during normal ship operation.

4.2.4 The test conditions required for the vibration and noise measurements are to be in accordance with the following conditions:

- (a) For passenger ships, prior to measurement surveys being carried out, the ship operating condition where the worst conditions are experienced between 0 and 85 per cent maximum continuous rating of the propulsion machinery is to be determined. To establish this condition, four measurement positions are to be defined with the agreement of LR and measurements taken of the parameters of interest at ship speeds corresponding to percentages of the maximum continuous rating of the propulsion machinery increasing up to 40 per cent MCR in 10 per cent intervals and from 40 per cent in 5 per cent intervals up to the 85 per cent maximum continuous rating of the propulsion machinery. If the 85 per cent maximum continuous rating condition is found to be the worst condition, then this will form the trial operating conditions. However, if a lower speed condition is found to be worse than the 85 per cent maximum continuous rating condition then both that condition and the 85 per cent maximum continuous rating condition will form the trial operating conditions. Where unavoidable any barred range within the values required for the trial operating condition may be excluded on agreement between Owner and Builder subject to approval by LR.
- (b) The power absorbed by the propeller(s) is to be that defined in *Pt 7, Ch 12, 4.2 Test conditions 4.2.4*. Alternatively, by special agreement, some lesser power could be accepted if it can be demonstrated by the Owner that this would correspond to a more representative normal service condition.
- (c) Auxiliary machinery essential for the ship's operating conditions together with HVAC systems are to be running at their normal rated capacity during the noise and vibration trials. Combinations of auxiliary machinery operation may be necessary. In addition, the following equipment is to be running if appropriate: stabilisers, waste treatment equipment, swimming pool and jacuzzi equipment.
- (d) For sea-going ships, measurements are to be taken with the ship proceeding ahead, at a constant speed and course, in a depth of water not less than five times the draught of the ship. For other ships, an appropriate water depth is to be agreed with LR prior to the trials.
- (e) Trials are to be conducted in sea conditions not greater than sea state 3 on the WMO sea state code. In addition, noise measurements should not be taken when the wind force exceeds 4 on the Beaufort scale.
- (f) The ship is to be at a displacement and trim representative of an operating condition.

- (g) Rudder angle variations are to be limited to $\pm 2^\circ$ of the midship position and rudder movements are to be kept to a minimum throughout the measurement periods.
- (h) In addition, for ships which are designed to spend a considerable period of time in harbour, the noise and vibration, are to be measured for this condition, with the auxiliary machinery and HVAC systems running at their normal rated capacity.
- (i) For passenger ships, intermittently run equipment such as transverse propulsion units are to be operated at 60 per cent of their rated power for additional measurements in surrounding ship areas.

4.2.5 Prior to survey, a test programme is to be submitted for approval by LR. This programme is to contain details of the following:

- (a) Measurement locations indicated on a general arrangement of the ship.
- (b) The ship's loading condition during survey.
- (c) The machinery operating condition, including HVAC system, during survey.
- (d) Noise and vibration measuring equipment.

4.3 Noise measurements

4.3.1 Noise measurements are to be conducted in accordance with ISO 2923 and IMO *Resolution MSC.337(91) – Adoption of the Code on Noise Levels on Board Ships – (Adopted on 30 November 2012)*The Annex below is consolidated into *Noise Levels - Code on Noise Levels on Board Ships (Resolution MSC.337(91))*. Measurements of noise levels are to be carried out using precision grade sound level meters conforming to IEC 60651, Type 1 or 2. Subject to demonstration, equivalent standards are acceptable.

4.3.2 Where the measured noise level exceeds the relevant criterion by 3 dB(A), or contains subjectively annoying low frequency noise or obvious tonal components, octave band readings are to be taken, with centre frequencies from 31,5 Hz to 8 kHz.

4.3.3 When outfitting is complete, and all soft furnishings are in place, sound insulation indices for passenger spaces are to be determined in accordance with ISO 140. Cabin to cabin indices are to be determined from a minimum of three locations within the passenger accommodation, the number of test locations being agreed with LR.

4.3.4 If required, impact sound measurements are to be carried out in accordance with ISO 140/7 and presented in accordance with ISO 717/2. See Pt 7, Ch 12, 4.4 Noise measurement locations 4.4.4.

4.4 Noise measurement locations

4.4.1 Measurement locations are to be chosen so that the assessment represents the overall noise environment on board the ship. In addition to the requirements of IMO *Resolution MSC.337(91) – Adoption of the Code on Noise Levels on Board Ships – (Adopted on 30 November 2012)*The Annex below is consolidated into *Noise Levels - Code on Noise Levels on Board Ships (Resolution MSC.337(91))* for crew spaces, all public spaces and at least 50 per cent of passenger cabins in the after third of the ship, and 25 per cent elsewhere, are to be surveyed. Distribution of the measurement locations is to be agreed by LR.

4.4.2 During measurement trials, recognised noise sources are to be operated at their normal level of noise output (e.g. machinery at design rating).

4.4.3 In larger sized spaces, where noise levels may vary considerably, such as restaurants, lounges, atria and open deck recreation areas, measurements are to be taken at locations not greater than 7 m apart.

4.4.4 The number of and locations for impact noise measurements are to be agreed between the Builder, Owner and LR. The measurements are to be carried out when the ship is in harbour. The number and location of measurements are to take account of all different combinations of construction, areas of application, types of cabin and spaces below.

4.5 Vibration measurements

4.5.1 Vibration measurements are to be conducted in accordance with ISO 6954:2000.

4.5.2 Measurements are to be made with instrumentation meeting the requirements of ISO 8041.

4.5.3 Vibration levels are to be given in terms of the velocity measurement appropriate to the version of the standard being used and should be measured over a period of not less than one minute.

4.6 Vibration measurement locations

4.6.1 Measurement locations are to be chosen so that the assessment represents the overall vibration environment onboard the ship. To minimise survey times, readings may be taken at the locations previously defined for the noise assessment part of the survey.

4.6.2 In cabins, vibration readings are to be taken in the centre of the floor area. The measurements are to indicate the vibration of the deck structure. In large spaces, such as restaurants, sufficient measurements are required to define the vibration profile.

4.6.3 Where deck coverings make transducer attachment impracticable, use of a small steel plate having a mass of at least 1 kg, with spikes as appropriate, is permissible.

4.6.4 At all locations, vibrations in the vertical direction are to be assessed. Sufficient measurements in the athwartships and fore and aft directions are to be taken to define global deck vibrations.

4.7 Approved technical organisation

4.7.1 An approved technical organisation for the purposes of these Rules is one that is acceptable to the Owner and LR with proven capability in noise and vibration measurement and satisfies all the criteria set out below:

- (a) Have instrumentation whose calibration, both before and after the measurements, can be traced back to National Standards and, hence, back to International Standards.
- (b) Have analysis procedures capable of data reduction to the requirements and standards set out in these Rules.
- (c) Be able to provide a written report in English with contents as defined by *Pt 7, Ch 12, 5 Noise and vibration survey reporting*.

■ Section 5 Noise and vibration survey reporting

5.1 General

5.1.1 Prior to survey, a noise and vibration measurement plan is to be agreed by the Owner, Builder and LR.

5.1.2 The survey report is to comprise the data and analysis for both noise and vibration and is to be submitted to LR for consideration.

5.1.3 The survey report is to be prepared by the organisation undertaking the trial measurements, which may be an approved technical organisation or LR.

5.1.4 The survey report is to be submitted to LR's London Office (MCS/TID) for evaluation and confirmation that the results are in accordance with the noise and vibration levels specified in these Rules and/or agreed between the Owner and Builder. The assignment of a Class Notation or the issue of a Statement of Compliance will be subject to confirmation by LR MCS/TID.

5.2 Noise

5.2.1 The reporting of results is to comply with ISO 2923 and IMO *Resolution MSC.337(91) – Adoption of the Code on Noise Levels on Board Ships – (Adopted on 30 November 2012)* The Annex below is consolidated into *Noise Levels - Code on Noise Levels on Board Ships (Resolution MSC.337(91))*, and is to include:

- (a) Measurement locations indicated on a general arrangement plan including, where possible, the measured dB(A) level.
- (b) Tabulated dB(A) noise levels, together with octave band analysis for positions where the level exceeds the specified criterion by 3 dB(A), or where subjectively annoying low frequency or tonal components were present. The Noise Rating number is also to be given where octave band analyses have been conducted.
- (c) Ship and machinery details.
- (d) Trial details:
 - Loading condition.
 - Machinery operating condition.
 - Speed.
 - Average water depth under keel.

- Weather conditions.
- Sea state.
- (e) Details of measuring and analysis equipment (e.g. manufacturer, type and serial numbers), including frequency analysis parameters (e.g. resolution, averaging time, window function).
- (f) Copies of the relevant instrument calibration certificates, together with the results of field calibration checks.

5.3 Vibration

5.3.1 The report is to contain the following information:

- (a) Measurement positions indicated on a general arrangement plan.
- (b) Where ISO 6964:2000 is used, the frequency-weighted overall r.m.s. vibration levels tabulated for all measurement locations calculated using the weighting functions and methodology stated in the standard.
- (c) Ship and machinery details.
- (d) Trial details:
 - Loading condition.
 - Machinery operating condition.
 - Speed.
 - Average water depth under keel.
 - Weather conditions.
 - Sea state.
- (e) Frequency analysis parameters (e.g. resolution, averaging time and window function), if the analysis is done in the frequency domain.
- (f) Copies of the relevant instrument calibration certificates, together with the results of field calibration.

■ *Section 6* **Non-periodical survey requirements**

6.1 Class notation assignment

6.1.1 Where the assignment of a Class Notation or a Statement of Compliance is requested, an Initial Survey is to comprise sea trial or initial in-service testing, reporting and assessment against the criteria set out in these Rules.

6.1.2 The sea trial or initial in-service testing requirements are set out in *Pt 7, Ch 12, 4 Testing*, and are to be reported in accordance with *Pt 7, Ch 12, 5 Noise and vibration survey reporting* and evaluated against the requirements of Sections *Pt 7, Ch 12, 2 Noise* and *Pt 7, Ch 12, 3 Vibration*.

6.2 Maintenance of class notation through-life and following modifications

6.2.1 Where an Owner has requested assignment of a Class Notation, arrangements are to be agreed between LR and the Owner to record observations/complaints of excessive noise and vibration that have been such as to disturb the comfort of passengers and crew. The records of the observations are to be made available to the attending LR Surveyor at each Annual Survey.

6.2.2 Where the observations indicate that the noise and/or vibration levels may exceed the criteria relating to the Class Notation requirements and those measured at the Initial Survey, a measurement programme is to be agreed between the Owner and LR and measurements taken in accordance with these Rules.

6.2.3 A Renewal Survey may be required following modifications, alterations or repairs including replacement of major machinery items. It is the responsibility of the Owner to advise LR of such modifications.

■ **Section 7**
Referenced Standards

7.1 Noise

7.1.1 The following National and International Standards for noise are referred to in these Rules:

- ISO 2923, *Acoustics – Measurement of noise on board vessels.*
- ISO 717/1, *Acoustics – Rating of sound insulation in buildings and of building elements; Part 1: Airborne sound insulation.*
- ISO 717/2, *Acoustics – Rating of sound insulation in buildings and of building elements; Part 2: Impact sound insulation.*
- IMO Resolution MSC.337(91) – *Adoption of the Code on Noise Levels on Board Ships – (Adopted on 30 November 2012)The Annex below is consolidated into Noise Levels - Code on Noise Levels on Board Ships (Resolution MSC.337(91)).*
- IEC Publication 651, *Sound level meters.*
- ISO140/4, *Acoustics – Measurement of sound insulation in buildings and of building elements; Part 4: Field measurements of airborne sound insulation between rooms.*
- ISO 140/7, *Acoustics – Measurement of sound insulation in buildings and of building elements; Part 7: Field measurements of impact sound insulation of floors.*

7.2 Vibration

7.2.1 The following National and International Standards for vibration are referred to in these Rules:

- ISO 6954:2000, *Mechanical vibration and shock – Guidelines for the measurement, reporting and evaluation of vibration with regard to habitability on passenger and merchant ships.*
- ISO 8041, *Human response to vibration. Measuring instrumentation.*

Section

- 1 **General**
 - 2 **Essential features**
 - 3 **Electrical Connection**
 - 4 **Electrical System**
 - 5 **Control and monitoring**
 - 6 **Testing, trials and surveys**
-

■ *Section 1*
General

1.1 General

1.1.1 These optional requirements apply to the safety, reliability and availability of shipboard machinery, electrical and control engineering arrangements installed to permit continued operation of services by connection to an external electrical power supply in port. These requirements are additional to those applicable in other Parts of the Rules. Regular operation of ship's services from an external electrical power supply is often referred to as On-shore Power Supply, Cold Ironing, High Voltage Shore Connection or Alternative Marine Power.

1.1.2 These requirements are intended for application to the shipboard elements of designs where the connection(s) with external power supply arrangements are achieved by either extending ship cables from the ship to the external power supply connection points or by bringing external cables on board to connect to shipboard connection points. However, external equipment and machinery (including shore based transformers, circuit breakers, gantries, cables, connectors and control engineering arrangements) are not covered by classification or these requirements.

1.1.3 Compliance with these requirements is intended to assess the suitability of shipboard arrangements for the documented intended application and only addresses compatibility with external power supply arrangements that are suitable for connection to the installed ship arrangements.

1.1.4 Assessment of the overall compatibility and suitability of an external electrical power supply (including combined electrical and control engineering assessments, compliance with applicable regulations, operating practices and risk assessment, etc. as applicable) is necessary before connection and is the responsibility of the Owner. Elements of the overall assessment of compatibility will be required to be completed in advance to prepare for a ship visit to a port where it is intended to connect to an external power supply due to the need to involve competent and responsible parties.

1.2 Authorities and administrations

1.2.1 Additional requirements and/or restrictions may be imposed by the National Authority with which the ship is registered and/or by the appropriate Administration or Authorities within whose jurisdiction the ship is intended to operate and/or by the Owners or Authorities responsible for an external electrical power supply. Where such additional requirements are relevant, compliance is the responsibility of the Owner. If specifically requested, Lloyd's Register (hereinafter referred to as 'LR') may be able to provide a suitable statement of compliance.

1.2.2 Where additional requirements imposed by an Authority or Administration would result in a departure from the requirements of this Chapter, details demonstrating that safety, availability and reliability will not be adversely affected are to be submitted to LR for consideration.

1.3 Class notations

1.3.1 **OPS** machinery class notation may be assigned where machinery, electrical and control engineering arrangements installed onboard to permit continued operation of services by connection to an external electrical power supply are assessed and found to comply with the requirements of this Chapter.

1.4 Plans and information

1.4.1 Three copies of the plans and particulars in *Pt 7, Ch 13, 1.4 Plans and information 1.4.2 to Pt 7, Ch 13, 1.4 Plans and information 1.4.9* are to be submitted for consideration.

1.4.2 Operating Manuals that describe the intended methods of connection together with operating and monitoring instructions. Assessments of the external supplies that are to be connected to the ship together with the mooring and environmental conditions are to be included. Details of equipment and arrangements necessary to ensure safety when connecting, disconnecting, transferring electrical load, testing and operating are to be incorporated.

1.4.3 A Design Statement which details the Defined Operations. This statement is to include a description of the operating capability, functionality, limits and restrictions; in terms of:

- Connection Equipment, see *Pt 7, Ch 13, 1.6 Definitions 1.6.2*;
- Connection Equipment routes;
- mooring arrangements;
- environmental conditions including tidal and weather and, where applicable, electromagnetic conditions required to ensure compatibility or prevent damage caused by heating or sparking;
- Connection Equipment suitability for hazardous areas, see *Pt 7, Ch 13, 2.1 General requirements 2.1.4* and *Pt 6, Ch 2, 1.2 Documentation required for design review 1.2.6*
- arrangements for an external connection cable to be brought on board, where provided;
- Separation details, see *Pt 7, Ch 13, 3.2 Connection Equipment 3.2.7*;
- the rating of the arrangements;
- ratings and requirements for external power supplies, see *Pt 7, Ch 13, 3.1 General 3.1.10*; and
- the services to be supplied.

1.4.4 Arrangement plans of equipment, control stations, locations, routes to and from connections, openings and accesses and flexible or movable arrangements.

1.4.5 Operational and construction details of Connection Equipment, including any flexible or adjusting arrangements, including plugs and socket-outlets, see *Pt 7, Ch 13, 3.3 Connection cables, plugs and socket-outlets 3.3.4*.

1.4.6 Plans for control and electrical engineering arrangements required by *Pt 6, Ch 1 Control Engineering Systems* and *Pt 6, Ch 2 Electrical Engineering*, as applicable.

1.4.7 Details of type tests for Connection cables, plugs and socket-outlets required by *Pt 7, Ch 13, 3.3 Connection cables, plugs and socket-outlets 3.3.6*.

1.4.8 Details of supplementary arrangements required to protect equipment from exposure to moisture, condensation or temperatures outside their rating.

1.4.9 Schedule of testing at manufacturers' works, initial surveys and trials. The test schedules are to address the defined operations and are to include normal operations and failure conditions.

1.5 Additions and alterations

1.5.1 When an alteration or addition to the approved arrangements is proposed, including changes to the defined service profile, details are to be submitted for consideration.

1.6 Definitions

1.6.1 'Defined Operations' include the application, connection, electrical load transfer, in-service operation, failure response, disconnection and stowage of the connection to an external power supply.

1.6.2 'Connection Equipment' is the ship equipment used to connect permanently installed ship equipment with external electrical power supply connection points in accordance with the Design Statement. This includes, as applicable, flexible cables, plugs and socket-outlets, slip rings or other power conductors or control connections, and support and management measures for these connections. For the purposes of this Chapter, 'Connection Equipment' does not include external equipment, see *Pt 7, Ch 13, 1.1 General*.

■ Section 2 Essential features

2.1 General requirements

2.1.1 Connection equipment is to be designed to be compatible with ship mooring arrangements and the limits of acceptable forces, moments and deflections on correctly applied Connection Equipment resulting from the movement of the moored ship under normal operational circumstances is to be defined in the Design Statement.

2.1.2 Electrical and control engineering arrangements for operation with external electrical power supplies are to be in accordance with the requirements of *Pt 6, Ch 1 Control Engineering Systems* and *Pt 6, Ch 2 Electrical Engineering*, as applicable.

2.1.3 Connection to an external electrical power supply is not to adversely affect the availability of main, auxiliary or emergency machinery, including ship sources of electrical power to allow ship power to be restored. Details of arrangements provided to maintain availability (for example, pre-heating and lubrication and availability of starting, fuel, lubrication, air and auxiliary systems) are to be included in the Design Statement, see also *Pt 7, Ch 13, 4.5 Ship power restoration* and *Pt 7, Ch 13, 5.1 General 5.1.9*.

2.1.4 The permanent or temporary installation of electrical equipment in areas containing flammable gas or vapour and/or combustible dust, is to be minimised as far as is consistent with operational necessity and the provision of facilities enhancing the overall safety of the ship and connection to an external power supply. Where it is necessary to install electrical equipment in these areas, the arrangements are to be in accordance with the requirements of *Pt 6, Ch 2, 14 Electrical equipment for use in explosive gas atmospheres or in the presence of combustible dusts*. The suitability of electrical Connection Equipment for operation in areas containing flammable gas and/or vapour and/or combustible dust while in port is to be defined in the Design Statement and should, additionally, address the implications for Connection Equipment extended ashore, where applicable, and the suitability for operation in berths requiring extended, hazardous areas.

2.1.5 As far as practicable, Connection Equipment is to be located outside of areas where it could be damaged by inport activities under normal operational circumstances.

2.1.6 Consideration may be given to arrangements that are considered by LR to provide an equivalent level of safety. Evidence demonstrating compliance with IEC/ISO/IEEE 80005-1: *Electrical installations in ships – Special features: High-voltage shore connection systems*, or a relevant National Standard may be submitted for consideration of acceptability by LR.

■ Section 3 Electrical Connection

3.1 General

3.1.1 A connection cubicle is to be provided at a convenient location for the reception or extension of connection cable(s) for connection to the external electrical power supply connection points. The connection cubicle is to contain terminals for the connection cable(s) that can be isolated.

3.1.2 Power connections with external electrical power supply arrangements may be made with either suitable connections or by using socket-outlets and plugs in accordance with *Pt 7, Ch 13, 3.3 Connection cables, plugs and socket-outlets*.

3.1.3 Suitable cables, permanently fixed, are to be provided from the connection cubicle to the Connection Circuit-Breaker switchboard, with on-board overcurrent protection situated at or as close as is practicable to the connection cubicle. Connection Equipment to this overcurrent protection is to be installed in a manner such as to minimise the risk of short-circuit.

3.1.4 Where shipboard connection cables are extended to the external electrical power supply connection points, the connection cubicle is to be situated as close as practicable on board to the point where they are extended from the ship.

3.1.5 Means are to be provided to permit the quality of insulation between Connection Equipment conductors, and between the conductors and earth to be measured to verify suitability prior to the connection of an external power supply. The means of verifying satisfactory insulation quality of Connection Equipment in hazardous areas is to be addressed in the Operating Manuals, see *Pt 7, Ch 13, 1.4 Plans and information 1.4.2*.

3.1.6 An earth connection is to be provided for connecting the hull to an earth appropriate for the external electrical power supply which is being connected.

3.1.7 For high voltage connections, means are to be provided, as applicable to the design, to either:

- (a) permit termination of circuits used by external power supply equipment to monitor the continuity of the earth connection referred to in *Pt 7, Ch 13, 3.1 General 3.1.6*; or
- (b) monitor the continuity of the earth connection referred to in *Pt 7, Ch 13, 3.1 General 3.1.6*, see *Pt 7, Ch 13, 5.3 Emergency Shutdown 5.3.8*.

3.1.8 Means are to be provided for checking the phase sequence of the incoming supply.

3.1.9 An indicator is to be provided at the Connection Circuit-Breaker switchboard, and at the connection cubicle if in a different location, in order to show when connections are energised.

3.1.10 Requirements for an external electrical power supply to be connected are to be defined in the Design Statement and this is to detail the following:

- connections, including control, alarm and safety systems and data communication links;
- Emergency Shutdown requirements, see *Pt 7, Ch 13, 5.3 Emergency Shutdown*;
- nominal voltage(s) or voltage range;
- nominal frequency or frequency range;
- number of phases and system of supply;
- rated current or apparent power;
- quality of power supply;
- reference to protection system design, including protection characteristics for the Connection Circuit-Breaker;
- maximum permitted prospective fault level;
- minimum supply apparent power or current capacity;
- earth fault limiting requirements for earthed high voltage connections;
- isolation and earthing; and
- supply requirements for lightning and surge protection, galvanic isolation of supply circuit from other ships, etc.

Required electrical characteristics are to address steady state, transient and fault conditions, as necessary.

3.1.11 A notice is to be provided at the connection cubicle referencing the Operating Manuals and Design Statement and advising of the requirement to ensure that external electrical power supplies satisfy the requirements of *Pt 7, Ch 13, 3.1 General 3.1.10* prior to connection. See *Pt 7, Ch 13, 1.1 General 1.1.4* for the conducting of the assessment of overall compatibility.

3.2 Connection Equipment

3.2.1 Connection Equipment support and management arrangements, including those for control engineering arrangements, are to be arranged not to apply damaging forces or tension to correctly applied equipment. Support arrangements are to ensure that the weight of connected cable is not borne by cable end terminations or connections, including those in plugs or socket-outlets.

3.2.2 Connection Equipment arrangements are to be such as not to coil or twist correctly applied equipment in a manner that would result in heating or physical tension beyond its rating during Defined Operations.

3.2.3 Where Connection Equipment passes through support or management arrangements or structural openings or is placed against structures, it is to be suitably protected against damage having regard to the Defined Operations.

3.2.4 Connection Equipment routes are not to reduce the effectiveness of openings required for the safety of the ship, for instance bulkhead or deck penetrations, watertight or fire doors.

3.2.5 Connection Equipment support and management arrangements are to be able to operate satisfactorily without damage during the Defined Operations.

3.2.6 Means are to be provided for Connection Equipment to be readily and safely adjusted in response to tidal changes, and other movements that could lead to damage or failure of connections, during the Defined Operations.

3.2.7 Connections with external electrical power supply arrangements are to be designed to prevent damage to the ship structure or Connection Equipment cable reels, cranes and/or gantries as a result of the connections separating in the event of the ship leaving a berth inadvertently or as a result of high cable tension for other reasons. Evidence of compliance with this requirement is to be included in the submission required by *Pt 7, Ch 13, 1.4 Plans and information 1.4.3* and is to identify

Connection Equipment (weak points) that will be damaged, if any, in the event of separation. Damage to connection cables, plugs and socket outlets or other identified equipment may be considered.

3.2.8 Connection Equipment cable reels, cranes and/or gantries used to manage, handle or adjust connection cables, plugs and/or socket-outlets, are to be designed and manufactured in accordance with applicable LR Rules or a marine standard acceptable to LR. A manufacturer's certificate verifying suitability for safe and effective operation for the Defined Operations and service profile is to be submitted.

3.2.9 The manufacturer's certificate referred to in *Pt 7, Ch 13, 3.2 Connection Equipment 3.2.8* is to be in the English language and include the following information:

- (a) Design and manufacturing standard(s) used.
- (b) Materials used for construction of key components and their sources.
- (c) Details of the quality control system applied during design, manufacture and testing.
- (d) Details of any existing type approval or type testing.
- (e) Details of installation and testing recommendations.

The manufacturer is to have a recognised quality management system certified by an IACS member or a Notified Body.

3.2.10 Connection cubicle and connection equipment locations are to have warning notices placed in prominent positions to indicate the presence of moving equipment, electricity and high voltage as applicable.

3.2.11 Effective means are to be provided to prevent the accumulation of moisture and condensation within equipment enclosures. Failure of heaters and/or ventilation fans provided to satisfy this requirement is to activate an alarm at a machinery control station that is attended while connected to an external power supply. The installation of open deck enclosures for high voltage connections is to be minimised to that required for the Defined Operations; a technical justification, including proposed degree of protection ratings, is to be included in the submission required by *Pt 7, Ch 13, 1.4 Plans and information 1.4.8*.

3.2.12 Connection Equipment support and management arrangements are to ensure that the correctly applied equipment is kept clear of areas where they may be exposed to moisture or temperatures outside their rating.

3.2.13 Arrangements are to be provided for stowage of on-board equipment when not in use such that equipment:

- will not be exposed to environmental conditions outside its rating;
- can be stowed, stored and removed without damage; and
- does not present a hazard during normal ship operation.

Adapters, extensions and parts dismantled after use are also to be provided with stowage arrangements.

3.3 Connection cables, plugs and socket-outlets

3.3.1 Plugs and socket-outlets for external electrical power supply connection points, including those for external control engineering arrangements, are to be designed constructed and tested in accordance with IEC 62613-1: *Plugs, socket-outlets and ship couplers for high-voltage shore connection systems (HVSC Systems) – Part 1: General requirements* or a relevant National Standard.

3.3.2 Plugs are to conform to applicable requirements that ensure compatibility with the intended socket-outlet type. Compatible plugs and socket-outlets are to be in accordance with IEC 62613-2: *Plugs, socket-outlets and ship couplers for high-voltage shore connection systems (HVSC-Systems) – Part 2: Dimensional compatibility and interchangeability requirements for accessories to be used by various types of ships* or a relevant National Standard.

3.3.3 Type tests are to be carried out on power connection plug and socket-outlets and cables, in accordance with IEC 62613-1: *Plugs, socket-outlets and ship couplers for high-voltage shore connection systems (HVSC Systems) – Part 1: General requirements* and Annex A.3 of the IEC/ISO/IEEE 80005-1:2012: *Electrical installations in ships – Special features: High-voltage shore connection systems respectively* or a relevant National Standard, to verify design suitability for the intended application described in the Design Statement. Type test reports are to be submitted that include details of the standards, the tests conducted and their order and the acceptance criteria. Alternative proposals may be submitted for consideration.

3.3.4 Power connection plugs and socket-outlets are to be assigned with ratings based on testing in accordance with IEC 62613-1: *Plugs, socket-outlets and ship couplers for high-voltage shore connection systems (HVSC Systems) – Part 1: General requirements* or a relevant National Standard. Details are to be provided in the submission required by *Pt 7, Ch 13, 1.4 Plans and information 1.4.5*.

3.3.5 Power connection plugs and socket-outlets are to be located to minimise the potential of arc flash hazards and suitable warning notices are to be provided at locations along Connection Equipment routes, including power connection plugs and socket-outlets operational locations.

3.3.6 Connection Equipment power cables are to be Type Approved in accordance with LR's *Type Approval System Test Specification Number 3* or, alternatively, surveyed by the Surveyors during manufacture and testing to assess compliance with *Pt 7, Ch 13, 3.3 Connection cables, plugs and socket-outlets 3.3.3* and application of an acceptable quality management system. Connection equipment cables are to be installed so as to minimise the risk of short-circuit when correctly applied.

3.4 Containers

3.4.1 Connection Equipment installed in removable containers is to satisfy the additional requirements of this sub- Section.

3.4.2 Containers are to be for the ship's exclusive use and are to be provided with a permanent notice indicating the ship name and IMO Ship Number.

3.4.3 Container locations are to be designated and identified in the plans required by *Pt 7, Ch 13, 1.4 Plans and information 1.4.4* and provided with fixings that are suitable for the Defined Operations. Procedures for container fixing, use and movement are to be included in the Operating Manuals.

3.4.4 The container type is to be a steel, closed type, weatherproof construction sufficient to prevent damage during expected use, for example during loading and unloading.

3.4.5 Measures necessary to prevent movement of the container when the container has electrical cables connected are to be provided.

3.4.6 Suitable protection is to be provided to prevent damage to Connection Equipment at the container entry points.

3.4.7 Suitable safe access is to be provided to the container for the Defined Operations, inspection and maintenance.

3.4.8 Container entry points are to be provided with suitable sealing arrangements to prevent the ingress of water into the container.

3.4.9 Containers are to be provided with effective means of ventilation. Where a container ventilation fan is provided, alarms are to be provided in accordance with *Pt 7, Ch 13, 3.2 Connection Equipment 3.2.11*.

3.5 High voltage in the presence of personnel

3.5.1 The Defined Operations are, as far as is practical, not to require personnel to be in the vicinity of high voltage equipment when it is energised.

3.5.2 For high voltage:

- (a) switchgear and controlgear assemblies;
- (b) cable reels, cranes and gantries; and
- (c) mounting enclosures for socket-outlets used to connect flexible cables to fixed connections;

arrangements are to be made to protect personnel in the event of gases, arc flash or vapours escaping under pressure as the result of arcing due to an internal fault. Where the Defined Operations require personnel to be in the vicinity of such equipment when it is energised, this may be achieved by an assembly that has been tested in accordance with Annex A of IEC 62271-200 and qualified for classification IAC (internal arc classification), or equivalent.

■ *Section 4* **Electrical System**

4.1 Electrical Load Transfer

4.1.1 'Dead transfer' arrangements are to be provided that permit transfer between operation using ship sources of electrical power and an external electrical power supply by disconnecting one from the ship distribution system and then connecting the other to the dead system.

4.1.2 Additional arrangements for connecting ship sources of electrical power and an external electrical power supply in parallel temporarily to transfer load from one to the other only are permitted, provided these are in accordance with *Pt 7, Ch 13, 4.1 Electrical Load Transfer 4.1.3 to Pt 7, Ch 13, 4.1 Electrical Load Transfer 4.1.9*.

4.1.3 Means to automatically synchronise a ship source of electrical power with an external electrical power supply and connect them in parallel for load transfer when requested by operating staff are to be provided.

4.1.4 Means to automatically transfer load between a ship source of electrical power and an external electrical power supply following their connection in parallel, are to be provided. The load transfer is to be completed in as short a time as practicable without causing machinery or equipment failure or operation of protective devices and this time is to be used as the basis for defining the Transfer Time Limit required by *Pt 7, Ch 13, 4.1 Electrical Load Transfer 4.1.5*.

4.1.5 When transferring of load between ship sources of electrical power and an external electrical power supply exceeds a defined Transfer Time Limit then, arrangements are to be such that:

- the transfer is aborted;
- load is removed from the ship sources of electrical power or external electrical power supply that was intended to take the load; and then
- the Connection Circuit-Breaker is opened.

An alarm is to be provided at a machinery control station that is attended when connected to an external electrical power supply when the Transfer Time Limit is exceeded and is to indicate the return to previous operating conditions.

4.1.6 The Transfer Time Limit referred to in *Pt 7, Ch 13, 4.1 Electrical Load Transfer 4.1.5* may be adjustable to match the ability of an external electrical power supply to accept and shed load. Setting of the Transfer Time Limit is to be demonstrated to the attending Surveyor at Surveys and Trials, see *Pt 7, Ch 13, 6.1 General*.

4.1.7 An external power supply may only be connected in parallel with a single ship source of electrical power. Arrangements are to be provided to ensure that this requirement is satisfied before and during parallel connection. Details of alternative proposals may be submitted for consideration.

4.1.8 Arrangements provided to adjust ship sources of electrical power to allow connection in parallel and transfer of load are not to cause machinery or equipment failure, operation of protective devices or damage under normal conditions or in the event of a failure.

4.1.9 Where load reductions are required to transfer load they are not to result in loss of essential services or the loss of availability of emergency services. Means are to be provided to readily make necessary load reductions and re-instate supplies following transfer.

4.2 Capacity

4.2.1 Arrangements for operating from external supplies are to be sufficiently rated to supply the following:

- essential services normally required in port;
- emergency services;
- services required to ensure ready availability of non-operating main and auxiliary machinery;
- services required to prevent damage to cargo or stores; and
- the services required for the Defined Operations.

The schedule of loads required by *Pt 6, Ch 2, 1.3 Documentation required for supporting evidence 1.3.3* is to incorporate operation when connected to an external electrical power supply.

4.2.2 The maximum electrical step load switched on or off is not to cause the power supply quality to exceed the parameters given in *Pt 6, Ch 2, 1.8 Quality of power supplies* or failure when connected to an external electrical power supply in accordance with the defined requirements, see *Pt 7, Ch 13, 3.1 General 3.1.10*.

4.2.3 Consideration is to be given to providing means to inhibit automatically the connection of large motors, or the connection of other large loads, that the arrangements are not rated to supply when connected to an external electrical power supply having the defined minimum apparent power or current capacity, see *Pt 7, Ch 13, 3.1 General 3.1.10* and *Pt 6, Ch 2, 6.9 Load management 6.9.4*.

4.3 Protection

4.3.1 Where an external electrical power supply is not arranged to operate in parallel with ship sources of electrical power, the connection to the external electrical power supply is to be provided with a Connection Circuit-Breaker arranged to open simultaneously, in the event of short-circuit, overload or undervoltage, all insulated poles.

4.3.2 Where an external electrical power supply is arranged to operate in parallel with ship sources of electrical power during load transfer, the connection to the external electrical power supply is to be provided with a Connection Circuit-Breaker arranged to open simultaneously, in the event of a short-circuit, an overload or an undervoltage, all insulated poles. This circuit-breaker is to be provided with reverse power protection with time delay, selected or set within the limits of 2 per cent to 15 per cent of full load to a value fixed in accordance with the rating defined in the Design Statement; a fall of 50 per cent in the applied voltage is not to render the reverse power mechanism inoperative, although it may alter the amount of reverse power required to open the circuit breaker.

4.3.3 The electrical system, including short-circuit protective device rating, is to be suitable for the highest prospective fault level at the point of installation. The short-circuit current calculations required by *Pt 6, Ch 2, 1.2 Documentation required for design review 1.2.6* are to identify the system state that would result in the highest prospective fault level. The highest prospective fault level may occur during parallel connection with an external power supply and the resulting combination of:

- (a) ship sources of electrical power, taking into account *Pt 7, Ch 13, 4.1 Electrical Load Transfer 4.1.7*; and
- (b) an external electrical power supply having the defined maximum permitted prospective fault level, see *Pt 7, Ch 13, 4.1 Electrical Load Transfer 4.1.7*.

Details of alternative proposals may be submitted for consideration.

4.3.4 The connection circuit is to be arranged such that contamination due to the products of arcing as a result of a fault in the Connection Circuit-Breaker enclosure on the external power supply side will not result in essential or emergency services not being available when supplied by ship sources of electrical power.

4.3.5 Initial connection of an external electrical power supply to the ship switchboards or converter equipment to connect to ship loads is to be arranged to be made by closing of the Connection Circuit-Breaker only.

4.3.6 Converter equipment used to connect an external electrical power supply to the ship electrical system is to ensure that a supply that would result in damage is not applied to the connected ship electrical systems in the event of a failure.

4.3.7 The voltage and time delay settings of the Connection Circuit-Breaker undervoltage release mechanism(s) are to be selected to ensure that the discriminative action required by *Pt 6, Ch 2, 6.1 General 6.1.1* is maintained.

4.3.8 Means are to be provided to prevent closure of the Connection Circuit-Breaker when a connected external electrical power supply has a different phase rotation or has a voltage or frequency that does not match the ship electrical system rating within the tolerances defined by *Pt 6, Ch 2, 1.8 Quality of power supplies 1.8.2* or *Pt 6, Ch 2, 1.8 Quality of power supplies 1.8.4*. Signals are to be provided, where necessary, to allow comparison with ship electrical system characteristics.

4.3.9 Connection power circuits are to be provided with protection against earth faults in accordance with *Pt 6, Ch 2, 6.4 Protection against earth faults*.

4.4 Interlocking and synchronising arrangements

4.4.1 External electrical power supply connections are to be provided with instruments and devices on board equivalent to those required for alternating current generators by *Pt 6, Ch 2, 7.11 Instruments for alternating current generators 7.11.1* where synchronising is not provided, or by *Pt 6, Ch 2, 7.11 Instruments for alternating current generators 7.11.2* to *Pt 6, Ch 2, 7.11 Instruments for alternating current generators 7.11.3* where synchronising for load transfer is provided. See also *Pt 6, Ch 2, 7.11 Instruments for alternating current generators* and *Pt 6, Ch 2, 7.12 Instrument scales*.

4.4.2 Means are to be provided to ensure that a source of electrical power or electrical power supply can only be connected to other live parts when synchronised. See also *Pt 7, Ch 13, 4.1 Electrical Load Transfer 4.1.2* for temporary parallel connection for load transfer.

4.4.3 The arrangements are to prevent Connection Equipment power conductors being made live by connecting to the ship electrical system.

4.4.4 The simultaneous connection of a ship source of electrical power and external electrical power supply to the same dead part of the electrical system is to be prevented.

4.4.5 For high-voltage connections, suitable means are to be provided to earth the connection power circuit so that it is discharged and so maintained that it is safe to touch.

4.4.6 Means provided to connect a connection power circuit to earth are to be arranged such that the circuit may only be earthed when it is isolated.

4.4.7 Interlocking arrangements are to be provided to prevent the connection of a high-voltage external power supply to a switchboard connected to earth using the means required by *Pt 6, Ch 2, 7.8 Earthing of high-voltage switchboards*.

4.5 Ship power restoration

4.5.1 When the ship main source of electrical power is shutdown and failure of the connected external electrical power supply occurs, the Connection Circuit-Breaker is to be arranged to automatically open followed by:

- (a) connection of the emergency source of electrical power to emergency services in accordance with *Pt 6, Ch 2, 3.3 Emergency source of electrical power in passenger ships 3.3.1* or *Pt 6, Ch 2, 3.4 Emergency source of electrical power in cargo ships 3.4.1* as applicable; and
- (b) automatic connection of the transitional source of electrical power to emergency services in accordance with *Pt 6, Ch 2, 3.3 Emergency source of electrical power in passenger ships 3.3.1* or *Pt 6, Ch 2, 3.4 Emergency source of electrical power in cargo ships 3.4.1* as applicable; and
- (c) automatic starting and connecting to the main switchboard of the main source of electrical power and automatic sequential restarting of essential services, in as short a time as is practicable. *See also Pt 7, Ch 13, 2.1 General requirements 2.1.3* and *Pt 6, Ch 2, 2.2 Number and rating of generators and converting equipment 2.2.3*.

Failures include loss of power, disconnection, phase failure and quality of supply outside the tolerances given in *Pt 6, Ch 2, 1.8 Quality of power supplies 1.8.2* or *Pt 6, Ch 2, 1.8 Quality of power supplies 1.8.4*.

4.5.2 An alarm is to be provided at a machinery control station that is attended when connected to an external electrical power supply to indicate activation of the automatic power supply failure response required by *Pt 7, Ch 13, 4.5 Ship power restoration 4.5.1*. The alarm is to indicate the failure that caused the activation.

4.5.3 The automatic power supply failure response required by *Pt 7, Ch 13, 4.5 Ship power restoration 4.5.1* is to be inhibited during the 'dead transfer' required by *Pt 7, Ch 13, 4.1 Electrical Load Transfer 4.1.1* but arrangements are to permit personnel to readily revert to operation from ship sources of electrical power if the 'dead transfer' to the external electrical power supply is not completed.

■ Section 5 Control and monitoring

5.1 General

5.1.1 Control engineering arrangements are to be in accordance with *Pt 6, Ch 1 Control Engineering Systems*, as applicable. The connection of, and the electrical load transfer to and from, an external electrical power supply are only to be controlled on board using shipboard arrangements.

5.1.2 External control of ship equipment may only be provided when in accordance with *Pt 7, Ch 13, 5.1 General 5.1.5*. Otherwise, external arrangements may be used to send requests for action to ship personnel for consideration.

5.1.3 Integration or connection with external, control, alarm and safety systems is to be 'fail-safe'.

5.1.4 The effects of failure of control, alarm and safety system and data communication link connections are to be documented along with resulting failure responses in the submission required by *Pt 7, Ch 13, 1.4 Plans and information 1.4.6*.

5.1.5 Details of proposals that would involve external control of ship equipment to respond to potentially hazardous situations detected externally are to be submitted for consideration. Provided that the arrangements are considered to be in accordance with the provisions of an acceptable and relevant standard, the following external control functions may be permitted:

- initiation of load reductions;
- initiation of electrical load transfer to ship sources of electrical power; and
- initiation of Emergency Shutdown.

5.1.6 The connection power circuit is to be isolated, and for high-voltage connections connected to earth so that it is discharged and so maintained that it is safe to touch, until the connections necessary for safe and effective operation are correctly established, including control, alarm and safety system and data communication link connections.

5.1.7 Following the correct establishment of the necessary connections in accordance with *Pt 7, Ch 13, 5.1 General 5.1.6*:

- where applicable, the connection power circuit may be disconnected from earth; and arranged such that only then
- may the request to make the external power supply connection points live described in *Pt 7, Ch 13, 5.1 General 5.1.8* be sent.

5.1.8 Ship control system arrangements are to be provided to request the external electrical power supply conductors to be:

- where applicable, disconnected from earth; and then
- made live up to the connection points.

5.1.9 An alarm is to be provided at a machinery control station that is attended when connected to an external electrical power supply upon failure of arrangements required to maintain ready availability in accordance with *Pt 7, Ch 13, 2.1 General requirements 2.1.3* (for example pre-heating).

5.1.10 Additional alarms with their associated safeguards are indicated in *Table 13.5.1 Additional alarms and associated safeguards*. These are in addition to those required by other Parts of the Rules.

5.1.11 Means are to be provided to allow testing of control, alarm and safety system connections with external arrangements, including operation of Emergency Shutdown facilities, before electrical connection to an external power supply.

5.1.12 If, depending upon the in-port shipboard work organisation, no machinery control stations are continuously attended while connected to an external power supply, then alarm transfer arrangements that activate an audible indication to warn relevant duty personnel of alarm initiation may be accepted. An audible warning from any portable devices is to be provided in the event of loss of the wireless link.

5.2 Connection Equipment control and monitoring

5.2.1 Connection Equipment is to be capable of unattended operation under normal operating conditions after correct application of the connection. Remote indication of active ship equipment faults at a machinery control station that is attended when connected to an external electrical power supply is to be provided. Details of arrangements that involve periodic attendance to inspect and adjust Connection Equipment may be submitted for consideration.

5.2.2 A control station is to be provided locally to Connection Equipment cable reel, cranes and gantries that permits identification of faults and permits safe and effective supervision and control of this equipment in the foreseeable environmental conditions.

5.2.3 A fixed means of two-way voice communication with a machinery control station that is attended when connected to an external electrical power supply is to be provided at the control station required by *Pt 7, Ch 13, 5.2 Connection Equipment control and monitoring 5.2.2*.

Table 13.5.1 Additional alarms and associated safeguards

Item	Alarm	Note
Presence of voltage on connections		Indicators in accordance with <i>Pt 7, Ch 13, 3.1 General 3.1.9</i> .
Transfer of load	Time limit exceeded	Return to previous operating state to be indicated, see <i>Pt 7, Ch 13, 4.1 Electrical Load Transfer 4.1.5</i> .
Ship power restoration	Activation	See <i>Pt 7, Ch 13, 4.5 Ship power restoration 4.5.2</i> .
Arrangements to ensure main and auxiliary machinery availability	Failure	When shutdown. See <i>Pt 7, Ch 13, 5.1 General 5.1.9</i> .
Applied connection equipment status	Changed	Indication to be provided also. See <i>Pt 7, Ch 13, 5.2 Connection Equipment control and monitoring 5.2.4</i> and <i>Pt 7, Ch 13, 5.2 Connection Equipment control and monitoring 5.2.5</i> .
Connection equipment	Close proximity to water level	See <i>Pt 7, Ch 13, 5.2 Connection Equipment control and monitoring 5.2.6</i>

Heaters and/or ventilation fans	Failure	See Pt 7, Ch 13, 3.2 Connection Equipment 3.2.11 and Pt 7, Ch 13, 3.4 Containers 3.4.9
Connection equipment tension	High	Emergency Shut-Down to be activated. See Pt 7, Ch 13, 5.3 Emergency Shutdown 5.3.11.
Plug connectors	Withdrawal	
Earth connection, if required. See Pt 7, Ch 13, 5.3 Emergency Shutdown 5.3.9	Loss of continuity	
Manual disconnection	Activation	
Plug and socket-outlet, if required. See Pt 7, Ch 13, 5.3 Emergency Shutdown 5.3.6	Not in locked position	
Switchgear enclosure mounted socket-outlets	Arc fault detection	

5.2.4 The control station required by Pt 7, Ch 13, 5.2 Connection Equipment control and monitoring 5.2.2 is to be provided with a means for operators to:

- select manual control; or
- lock equipment in position; or
- where provided, select automatic adjustment.

This status is to be indicated remotely at a machinery control station that is attended when connected to an external electrical power supply.

5.2.5 When the equipment status selection referred to in Pt 7, Ch 13, 5.2 Connection Equipment control and monitoring 5.2.4 is changed whilst an external electrical power supply is connected, an alarm is to be activated at a machinery control station that is attended when connected to an external electrical power supply.

5.2.6 Where correctly applied connection equipment is not protected from submersion in the water between the ship and shore (e.g. submersible equipment, equipment routing or slack cable prevention by torque control), an alarm is to be provided at a machinery control station that is attended when connected to an external electrical power supply when Connection Equipment approaches a situation where it may be submerged in the water between the ship and shore, for instance due to tidal changes. The time between alarm initiation and possible exposure to this water is to be sufficient to allow the equipment to be attended and adjusted prior to exposure to water.

5.3 Emergency Shutdown

5.3.1 The requirements of this sub-Section apply to arrangements for the emergency disconnection of live electrical power from the connection to an external electrical power supply.

5.3.2 Emergency Shutdown facilities are to be provided that, when activated, will instantaneously:

- isolate the connection from ship electrical power supplies; and
- request isolation of the external electrical power supply connection points.

5.3.3 High-voltage Connection Equipment is to be either:

- provided with permanent arrangements for manual discharging and routed to prevent personnel access to live connection cables and connection points by barriers and/or adequate distance(s) under expected operating conditions; or
- automatically discharged so that it is safe to touch with immediate initiation of switching device closure following the isolation from ship and shore electrical power supplies required by Pt 7, Ch 13, 5.3 Emergency Shutdown 5.3.2.

5.3.4 For ships that are intended to connect in ports where Connection Equipment may move into a hazardous area associated with the terminal or port area as a result of the ship inadvertently leaving the berthed position (slipping/ breaking of moorings, etc.), this condition is to be included in the Design Statement. The arrangements are to comply with Pt 7, Ch 13, 5.3 Emergency Shutdown 5.3.3 and, additionally, other electrically powered connection equipment that is not intrinsically safe is to be arranged for automatic isolation.

5.3.5 Means are to be provided to detect or predict tension in the external electrical power supply connection cable that activate the Emergency Shutdown facilities described in Pt 7, Ch 13, 5.3 Emergency Shutdown 5.3.2 before damage occurs.

Where alternative arrangements to tension detection are proposed (automatic break-away release, connectors with shear bolts and pilot lines, connection with ship/shore Emergency Shutdown system, etc.), details are to be submitted for consideration.

5.3.6 To detect and react to the withdrawal of plugs from socket-outlets while power supply connections are live, the Emergency Shutdown facilities described in *Pt 7, Ch 13, 5.3 Emergency Shutdown 5.3.2* are to be activated before the necessary degree of protection is no longer achieved or power connections are broken by the removal of a plug from a connected socket-outlet, including in-line connections.

5.3.7 For high-voltage connection points on board where the means of locking together plugs and socket-outlets required by *Pt 7, Ch 13, 3.3 Connection cables, plugs and socket-outlets 3.3.4* are not interlocked to prevent removal from the locked position when the Connection Equipment power connections are not discharged so that they are safe to touch, the Emergency Shutdown facilities described in *Pt 7, Ch 13, 5.3 Emergency Shutdown 5.3.2* are to be activated when connected plugs are moved from the locked position. Consideration may be given to relaxing this requirement when evidence is submitted which demonstrates that appropriate controls and procedures acceptable to LR are in place to control personnel access plugs and socket-outlets.

5.3.8 Where connection power plugs are connected to socket-outlets mounted on a switchgear enclosure, arrangements are to be provided to activate the Emergency Shutdown facilities described in *Pt 7, Ch 13, 5.3 Emergency Shutdown 5.3.2* in as short a time as practicable in the event of an arc occurring in the enclosure at the rear of the socket-outlets.

5.3.9 Where *Pt 7, Ch 13, 3.1 General 3.1.7* applies, the Emergency Shutdown facilities described in *Pt 7, Ch 13, 5.3 Emergency Shutdown 5.3.2* are to be activated in the event of loss of earth connection continuity being detected.

5.3.10 Means to manually activate the Emergency Shutdown facilities described in *Pt 7, Ch 13, 5.3 Emergency Shutdown 5.3.2* are to be provided at:

- a machinery control station that is attended when connected to an external electrical power supply;
- in close proximity to the connection cubicle; and
- at the switchboard where the fixed cable from the shore connection cubicle are received.

Additional manual activation facilities may also be provided at other locations where it is considered necessary. The means of activation are to be visible and prominent, prevent inadvertent operation and require a manual action to reset.

5.3.11 An alarm to indicate activation of the Emergency Shutdown is to be provided at a machinery control station that is attended when connected to an external electrical power supply. The alarm is to indicate the cause of the activation. For power supply restoration, see *Pt 7, Ch 13, 4.5 Ship power restoration 4.5.1* to *Pt 7, Ch 13, 4.5 Ship power restoration 4.5.3*.

■ Section 6 Testing, trials and surveys

6.1 General

6.1.1 The testing and trials required by *Pt 7, Ch 13, 6.1 General 6.1.2* to *Pt 7, Ch 13, 6.1 General 6.1.5* are to be successfully completed to the Surveyor's satisfaction before **OPS** notation may be assigned. Where appropriate test facilities cannot be provided, trials are likely to require the additional co-operation of a port facility with a suitable external electrical power supply and the ability to operate the defined services to be supplied during these trials and allow the testing described to be conducted.

6.1.2 Electrical and control engineering equipment is to be surveyed at manufacturer's works and undergo survey and operational trials on board in accordance with the approved test schedules and applicable testing requirements in *Pt 6, Ch 1 Control Engineering Systems* and *Pt 6, Ch 2 Electrical Engineering*.

6.1.3 In addition to *Pt 7, Ch 13, 6.1 General 6.1.2*, the following Connection Equipment, where applicable, is to be surveyed by the Surveyors during manufacture and testing:

- filters;
- converters; and
- slip ring assemblies.

6.1.4 Cable reels, cranes and/or gantry drives for Connection Equipment are to be surveyed and tested in accordance with applicable LR Rules and *Pt 7, Ch 13, 3.2 Connection Equipment 3.2.9*.

6.1.5 Trials are to be conducted when connected to a compatible external electrical power supply in accordance with *Pt 7, Ch 13, 3.1 General 3.1.10* to demonstrate to the attending Surveyor that the Rules have been complied with in respect of:

- (a) operation of connection management arrangements;
- (b) trials on cable lifting appliances (for example cable reels or cranes) are to be conducted that demonstrate suitability for the maximum mechanical load and duty required by the Defined Operations within the service profile contained in the Design Statement, including connection of extensions or adapters;
- (c) satisfactory performance of the connection and Connection Equipment throughout the Defined Operations, including a run with the defined services to be supplied operational;
- (d) temperature of electrical joints, connections, circuitbreakers and fuses;
- (e) the operation of electrical load transfer arrangements (including Transfer Time Limit setting), electrical system protection and interlocking devices, Emergency Shutdown arrangements and other safety devices and ship power restoration;
- (f) where acceptable type-test evidence is not submitted, connection break-away, see *Pt 7, Ch 13, 3.2 Connection Equipment 3.2.7*;
- (g) voltage regulation when the maximum load is suddenly thrown off and when starting the largest motor connected to the system;
- (h) where more than one external power supply connection can be operated in parallel, satisfactory load sharing at loads up to normal working load; and
- (i) voltage drop is to be measured, where necessary, to verify that this is not in excess of that specified in *Pt 6, Ch 2, 1.8 Quality of power supplies*.

6.1.6 Arrangements are to be:

- examined at Annual Survey; and
- examined and functionally tested whilst connected to an external electrical power supply during the Complete Surveys of machinery or, where this is not practical, within 12 months of the due date of the Complete Surveys of machinery.

This is to include examination of Connection Equipment.

Requirements for Machinery and Engineering Systems of Unconventional Design

Part 7, Chapter 14

Section 1

Section

1 Requirements for machinery and engineering systems of unconventional design

■ Section 1 Requirements for machinery and engineering systems of unconventional design

1.1 General - Scope and objectives

1.1.1 Consistent with the aims of the IMO guidelines for Formal Safety Assessment (MSC-MEPC. 2/Circ.12), the requirements of this Section aim to ensure that risks to maritime safety and the environment, stemming from the introduction of machinery or engineering systems of unconventional design, are addressed insofar as they affect the objectives of classification.

1.1.2 The requirements of this section are to be satisfied where:

- (a) machinery is required to be constructed, installed and tested in accordance with Lloyds Register's (hereinafter referred to as LR) Rules and Regulations and for which the corresponding machinery class notation is to be assigned (see *Pt 1, Ch 2, 2.4 Class notations (machinery)*), and,
- (b) the machinery and engineering systems are considered by LR to be of an unconventional design and which, as a result, are not directly addressed by LR's extant Rules and Regulations.

1.1.3 It is to be noted that as well as the requirements of this section, the general requirements of LR's Rules and Regulations are also to be satisfied as far as they are applicable.

1.1.4 Compliance with ISO15288 *Systems Engineering - System Life Cycle Processes* or an acceptable equivalent national standard may be accepted as meeting the requirements of *Pt 7, Ch 14, 1.3 Project Management* to *Pt 7, Ch 14, 1.11 Validation (certification and survey)*.

1.2 Information to be submitted

1.2.1 Information is to be submitted for assessment of compliance with the general requirements of LR's Rules and Regulations, including the general requirements for:

- (a) Machinery, see *Pt 5, Ch 1 General Requirements for the Design and Construction of Machinery*.
- (b) Steam raising plant and pressure vessels, see *Pt 5, Ch 10 Steam Raising Plant and Associated Pressure Vessels*.
- (c) Machinery and ship piping systems, see *Pt 5, Ch 12 Piping Design Requirements* to *Pt 5, Ch 14 Machinery Piping Systems*.
- (d) Control engineering, see *Pt 6, Ch 1 Control Engineering Systems*.
- (e) Electrical engineering see *Pt 6, Ch 2 Electrical Engineering*.
- (f) Materials, see *Rules for the Manufacture, Testing and Certification of Materials, July 2015*.

1.2.2 In addition to the information identified in *Pt 7, Ch 14, 1.2 Information to be submitted 1.2.1*, the information described in *Pt 7, Ch 14, 1.2 Information to be submitted 1.2.3* and *Pt 7, Ch 14, 1.2 Information to be submitted 1.2.4* is also to be submitted for consideration.

1.2.3 General description detailing the extent of the machinery or engineering system, the shipboard services it is to provide, its operating principles, and its functionality and capability when operating in the environment to which it is likely to be exposed under both normal and foreseeable abnormal conditions. The general description is to be supported by the following information as applicable:

- (a) System block diagram.
- (b) Piping and instrumentation diagrams.
- (c) Description of operating modes, including: Start-up, shut-down, automatic, reversionary, manual and emergency.
- (d) Description of safety related arrangements, including: Safeguards, automatic safety systems and interfaces with ships safety systems.
- (e) Description of connections to other shipboard machinery, equipment and systems, including: Electrical, mechanical, fluids and automation.
- (f) Plans of physical arrangements, including: Location, operational access and maintenance access.
- (g) Operating manuals, including:

Requirements for Machinery and Engineering Part 7, Chapter 14

Systems of Unconventional Design

Section 1

Instructions for start-up, operation, shut-down, instructions for maintenance, instructions for adjustments to the performance and functionality and details of risk mitigation arrangements.

(h) Maintenance manuals, including:

Instructions for routine maintenance, repair following failure, disposal of components and recommended spares inventory.

1.2.4 Project process documentation including:

- (a) Project Management Plan, see *Pt 7, Ch 14, 1.3 Project Management*.
- (b) Requirements Definition Document, see *Pt 7, Ch 14, 1.4 Requirements definition*.
- (c) Quality Assurance Plan, see *Pt 7, Ch 14, 1.5 Quality assurance*.
- (d) Design Definition Document, see *Pt 7, Ch 14, 1.6 Design definition*.
- (e) Risk Management Plan, see *Pt 7, Ch 14, 1.7 Risk management*.
- (f) Configuration Management Plan, see *Pt 7, Ch 14, 1.8 Configuration management*.
- (g) Verification Plan, see *Pt 7, Ch 14, 1.9 Verification*.
- (h) Integration Plan, see *Pt 7, Ch 14, 1.10 Integration*.
- (i) Validation Plan, certification and survey, see *Pt 7, Ch 14, 1.11 Validation (certification and survey)*.

1.3 Project Management

1.3.1 A project management procedure is to be established in order to define and manage the key project processes. The project processes are to include the processes described in *Pt 7, Ch 14, 1.4 Requirements definition* to *Pt 7, Ch 14, 1.11 Validation (certification and survey)*.

1.3.2 For the entire project, and each of the processes within the project, the project management procedure is to define the following:

- (a) Activities to be carried out.
- (b) Required inputs and outputs.
- (c) Roles of key personnel.
- (d) Responsibilities of key personnel.
- (e) Competence of key personnel.
- (f) Schedules for the activities.

1.4 Requirements definition

1.4.1 A requirements definition procedure is to be established in order to define the functional behaviour and performance of the machinery or engineering system required by individual stakeholders, in the environments to which the machinery or engineering system is likely to be exposed under both normal and foreseeable emergency conditions.

1.4.2 The procedure is to take account of requirements resulting from key stakeholders, including:

- (a) Ship's owner.
- (b) Ship's operator.
- (c) Ship's crew.
- (d) Shipyard.
- (e) Systems integrator.
- (f) Designers.
- (g) Maintenance personnel
- (h) Surveyors
- (i) Manufacturers and suppliers.
- (j) National Administration.
- (k) LR.

1.4.3 The procedure is to take account of requirements resulting from the following influences:

- (a) Ship operations, including:

Underway, manoeuvring, pilotage, docking, alongside and training exercises.
- (b) Ship conditions, including:

Requirements for Machinery and Engineering Part 7, Chapter 14

Systems of Unconventional Design

Normal operation, abnormal operation, blackout, deadship, fire in a single compartment and flooding of a single compartment.

- (c) Environmental conditions, including:

Temperature, humidity, water spray, salt mist, vibration, shock, inclination, electrical fields and magnetic fields.

- (d) Applicable provisions, including:

Statutory legislation, classification requirements, international standards, national standards and codes of practice.

- (e) Expected users, including:

Multi-national users with a range of national languages and cultures, fatigued users, users without dedicated training, and maintenance and survey personnel.

- (f) Design, construction and operational constraints, including:

Effect of particular design decisions or component choices on other aspects of design, risk and production engineering compromises, verification, integration and validation considerations, maintenance and disposal, and changes in use.

- 1.4.4 The procedure is to specify the functional behaviour and performance requirements and is to identify the source of the requirements.

1.5 Quality assurance

- 1.5.1 A quality assurance procedure is to be established in order to ensure that the quality of the machinery or engineering system is in accordance with a defined quality management system.

- 1.5.2 The procedure is to define the specific quality controls to be applied during the project in order to satisfy the requirements of the quality management system.

- 1.5.3 The quality management system is to satisfy the requirements of ISO9001:2000 *Quality management systems – Requirements*, or an equivalent acceptable National Standard.

1.6 Design definition

- 1.6.1 A design definition procedure is to be established in order to define the requirements for the design of machinery or an engineering system which satisfies stakeholder requirements, quality assurance requirements and complies with basic internationally recognised design requirements for safety and functionality.

- 1.6.2 The procedure is to ensure that the design of the machinery or engineering system satisfies:

- (a) Statutory legislation.
- (b) LR's requirements.
- (c) International Standards and Codes of Practice where relevant.

- 1.6.3 The procedure is to take account of stakeholder requirements, *see Pt 7, Ch 14, 1.4 Requirements definition*.

- 1.6.4 The procedure is to take account of quality assurance requirements, *see Pt 7, Ch 14, 1.5 Quality assurance*.

- 1.6.5 The procedure is to ensure that the requirements for the design of major components and subsystems of the machinery or engineering system can be verified before and after integration.

- 1.6.6 The procedure is to specify the design requirements and is to identify the source of the requirements.

- 1.6.7 Any deviations from stakeholder requirements are to be identified, justified and accepted by the originating stakeholder.

1.7 Risk management

- 1.7.1 A risk management procedure is to be established in order to ensure that any risks stemming from the introduction of the machinery or engineering system are addressed, in particular risks affecting:

- (a) The structural strength and integrity of the ship's hull.
- (b) The safety of shipboard machinery and engineering systems.
- (c) The safety of shipboard personnel.
- (d) The reliability of essential and emergency machinery and engineering systems.
- (e) The environment.

Requirements for Machinery and Engineering Part 7, Chapter 14

Systems of Unconventional Design

Section 1

1.7.2 The procedure is to consider the hazards associated with installation, operation, maintenance and disposal, both with the machinery or engineering system functioning correctly and following any reasonably foreseeable failure.

1.7.3 The procedure is to take account of stakeholder requirements, see *Pt 7, Ch 14, 1.4 Requirements definition*.

1.7.4 The procedure is to take account of design requirements, see *Pt 7, Ch 14, 1.6 Design definition*.

1.7.5 The procedure is to ensure that hazards are identified using acceptable and recognised hazard identification techniques, and that the effects of the following influences are considered:

(a) Ship operations, including:

Underway, manoeuvring, pilotage, docking, alongside and maintenance, commissioning and trials.

(b) Ship conditions, including:

Normal operation, blackout, dead-ship, fire in a single compartment and flooding of a single compartment.

(c) Modes of operation, including:

Start-up, running, shut-down, automatic, reversionary, manual and emergency.

(d) Environmental conditions, including:

Temperature, humidity, water spray, salt mist, vibration, shock, inclination, electrical fields and magnetic fields.

(e) Dependencies, including:

Power, fuel, air, cooling, heating, data and human input.

(f) Environmental impact, including:

Emissions to air, discharges to water, noise and waste products.

(g) Failures, including:

Human error, supply failure, system, machinery, equipment and component failure, random, systematic and common cause failures.

1.7.6 The procedure is to ensure that risks are analysed using acceptable and recognised risk analysis techniques and that the following effects are considered:

(a) Local effects:

Loss of function, component damage, fire, explosion, electric shock, harmful releases and hazardous releases.

(b) End effects on:

Services essential to the safety of the ship, services essential to the safety of shipboard personnel and services essential to the protection of the environment.

1.7.7 The procedure is to ensure that risks are eliminated wherever possible. Risks which cannot be eliminated are to be mitigated as necessary.

1.7.8 Details of risks, and the means by which they are mitigated, are to be included in the operating manual, see *Pt 7, Ch 14, 1.2 Information to be submitted 1.2.3*.

1.8 Configuration management

1.8.1 A configuration management procedure is to be established in order to ensure traceability of the configuration of the machinery or engineering system, its subsystems and its components.

1.8.2 The procedure is to identify items essential for the safety or operation of the machinery or engineering system (configuration control items) which could foreseeably be changed during the lifetime of the machinery or engineering system, including:

(a) Documentation.

(b) Software.

(c) Sensors.

(d) Actuators.

(e) Instrumentation.

(f) Valves.

(g) Pumps

Requirements for Machinery and Engineering Systems of Unconventional Design

Part 7, Chapter 14

Section 1

1.8.3 The procedure is to take account of the design requirements, *see Pt 7, Ch 14, 1.6 Design definition.*

1.8.4 The procedure is to include items used to mitigate risks, *see Pt 7, Ch 14, 1.7 Risk management.*

1.8.5 The procedure is to ensure that any changes to configuration control items are:

- (a) Identified.
- (b) Recorded.
- (c) Evaluated.
- (d) Approved.
- (e) Incorporated.
- (f) Verified.

1.9 Verification

1.9.1 A verification procedure is to be established in order to ensure that subsystems and major components of the machinery or engineering system satisfy their design requirements.

1.9.2 The procedure is to verify design requirements, *see Pt 7, Ch 14, 1.6 Design definition.*

1.9.3 The procedure is to identify the requirements to be verified, the means by which they are to be verified, and the points in the project at which verification is to be carried out.

1.9.4 The procedure is to be based on one or a combination of the following activities as appropriate:

- (a) Design review.
- (b) Product inspection.
- (c) Process audit.
- (d) Product testing.

1.10 Integration

1.10.1 An integration procedure is to be established in order to ensure that the machinery or engineering system is assembled in a sequence which allows verification of individual subsystems and major components following integration in advance of validating the entire machinery or engineering system.

1.10.2 The procedure is to take account of the verification requirements, *see Pt 7, Ch 14, 1.9 Verification.*

1.10.3 The procedure is to identify the subsystems and major components, the sequence in which they are to be integrated, the points in the project at which integration is to be carried out, and the points in the project at which verification is to be carried out.

1.11 Validation (certification and survey)

1.11.1 A validation procedure is to be established in order to ensure the functional behaviour and performance of the machinery or engineering system meets with its functional and performance requirements.

1.11.2 The procedure is to validate stakeholder requirements, *see Pt 7, Ch 14, 1.4 Requirements definition.*

1.11.3 The procedure is to validate arrangements required to mitigate risks, *see Pt 7, Ch 14, 1.7 Risk management.*

1.11.4 The procedure is to validate the traceability of the configuration control items, *see Pt 7, Ch 14, 1.8 Configuration management.*

1.11.5 The procedure is to identify the requirements to be validated, the means by which they are to be validated and the points in the project at which validation is to be carried out, including:

- (a) Factory acceptance testing.
- (b) Integration testing.
- (c) Commissioning.
- (d) Sea trials.
- (e) Survey.

Refrigeration Systems and Equipment Serving Provision Stores and Air-Conditioning Installations

Part 7, Chapter 15

Section 1

Section

- 1 **General requirements**
- 2 **Construction and installation**
- 3 **Refrigerating machinery and refrigerant storage compartment arrangements**
- 4 **Refrigerant detection systems**
- 5 **Control and monitoring and electrical power arrangements**
- 6 **Personnel safety equipment and systems**
- 7 **Testing and trials**

■ Section 1 General requirements

1.1 General

1.1.1 This Chapter states the requirements for ships having centralised refrigeration systems, designed to reject heat from refrigerated stores or from the air-conditioning and ventilation arrangements fitted to both passenger and crew accommodation spaces and are in addition to the relevant requirements of *Pt 5 Main and Auxiliary Machinery* and *Pt 6 Control, Electrical, Refrigeration and Fire*.

1.1.2 The requirements, which are optional, cover arrangements, equipment, and systems necessary for provision stores and air-conditioning arrangements as defined in *Pt 7, Ch 15, 1.1 General 1.1.3* and *Pt 7, Ch 15, 1.1 General 1.1.4*.

1.1.3 The refrigeration system is to include the refrigeration compressor(s), condenser(s), evaporator(s), direct expansion air handling and fan coil units, interconnecting primary refrigerant piping system and fittings.

Note For the purpose of these Rules, the term primary refrigerant system, unless otherwise stated, applies to primary refrigerant systems and secondary refrigerant systems containing volatile refrigerants.

1.1.4 These requirements are intended to mitigate risks associated with the safety of refrigeration and air-conditioning machinery, and do not cover air distribution ductwork, chilled water systems or the calculation and verification of air flow rates and cooling loads within the air conditioned or refrigerated spaces. The method used to calculate the capacity of the air-conditioning refrigeration equipment is the responsibility of the Shipbuilder and Owner and should be in accordance with a recognised code or standard such as ISO 7547:2002 *Ships and marine technology – Air-conditioning and ventilation of accommodation spaces – Design conditions and basis of calculations* or, ASHRAE 26-1996(RA2006) *Mechanical Refrigeration and Air-Conditioning Installations Aboard Ship*.

1.1.5 Ships complying with the applicable requirements of this Chapter will be eligible for the optional machinery class notation **RPA** (Refrigeration Machinery for Provision Stores and Air-conditioning).

1.2 Plans and information

1.2.1 The following plans and particulars, as applicable, and any others which may be specially requested for the refrigerating plant and systems, are to be submitted in triplicate for approval, before construction is commenced:

- (a) Schematic plans, including full particulars of piping and instrumentations, for:
 - (i) primary and secondary refrigerant systems containing a volatile fluid;
 - (ii) air cooler defrosting arrangements; and
 - (iii) condenser cooling water systems.
- (b) Detailed dimensioned plans and material specifications for:
 - (i) reciprocating compressor crankshaft and crankcase, where exposed to refrigerant pressure;
 - (ii) rotary-type compressor rotors and casing;
 - (iii) condensers, both shell and tube, and plate type;

Refrigeration Systems and Equipment Serving Provision Stores and Air-Conditioning Installations

Part 7, Chapter 15

Section 2

- (iv) evaporators, both shell and tube, and plate type;
 - (v) air coolers or arrangement of air cooling pipe grids and construction method;
 - (vi) liquid receivers;
 - (vii) oil separators; and
 - (viii) any other pressure vessels or heat exchangers containing primary refrigerants, see *Pt 5, Ch 11, 6.1 General*.
- (c) General arrangement of refrigerating machinery compartments in elevation and plan, showing location and arrangement of the plant, ventilation details and location of temperature sensors and refrigerant vapour detectors.
 - (d) Details of automatic controls, alarms and safety systems, see *Pt 6, Ch 1, 1 General requirements*.
 - (e) Details of primary refrigerant level indicators.
 - (f) Capacity calculations for pressure relief valves and/or bursting discs, and inlet and discharge pipework pressure drop calculations.
 - (g) Programme of tests to be conducted on completion of the installation, see *Pt 7, Ch 15, 7 Testing and trials*.

1.2.2 In addition to the applicable requirements detailed in *Pt 7, Ch 15, 1.2 Plans and information 1.2.1*, the following information is also to be submitted for air-conditioning refrigeration equipment:

- (a) Details of direct expansion fan coil units (FCUs).
- (b) Details of cooling coils, fitted to air handling units (AHUs) that contain primary refrigerant.
- (c) General arrangement drawing showing the location of the air-conditioning refrigeration equipment, direct expansion FCUs and AHUs throughout the ship.
- (d) Details of pressure testing procedures for the refrigeration equipment.

1.2.3 Plans showing the general arrangement of refrigeration plant compartments, together with a description of the equipment and arrangements installed for isolation and distribution of ventilation air and the electrical power supply systems. The plans are to indicate segregation and access arrangements for compartments and associated control rooms and control stations.

1.2.4 A statement of the intended design system capacity for the intended operating conditions for verification purposes at the trials required by *Pt 7, Ch 15, 7.2 Trials 7.2.1*.

1.2.5 A schedule of testing and trials to demonstrate that systems are capable of operating as designed and as required by *Pt 7, Ch 15, 7 Testing and trials*.

1.2.6 Operating manuals are to be submitted for information. The manuals are to include the following information:

- (a) Particulars and a description of the systems.
- (b) Operating instructions for the equipment and systems.
- (c) Maintenance instructions for the installed arrangements.

1.2.7 Evidence that the required performance of refrigeration systems, pump and fan equipment is capable of being maintained under ambient and inclination operating conditions defined in *Pt 5, Ch 1, 3.5 Ambient reference conditions* and *Pt 5, Ch 1, 3.6 Ambient operating conditions* is to be provided by the manufacturer.

■ Section 2

Construction and installation

2.1 Materials

2.1.1 The selection of materials for piping systems in provision store refrigeration systems is to take account of the following:

- (a) The pressures and temperatures of the refrigerant fluids.
- (b) Locations of systems and equipment.
- (c) Compatibility of materials.
- (d) Fluid flow rates and static pressure conditions.
- (e) Minimising corrosion and erosion through life of system.
- (f) Refrigerant flammability and toxicity.

Refrigeration Systems and Equipment Serving Provision Stores and Air-Conditioning Installations

Part 7, Chapter 15

Section 2

2.1.2 Pipes, valves and fittings are in general to be made of steel, ductile cast iron, copper, copper alloy, or other approved ductile material suitable for the intended purpose. The use of plastics materials is also acceptable subject to the restrictions in *Pt 5, Ch 12, 5 Plastics pipes*.

2.1.3 Where applicable, the piping systems are to comply with the requirements of *Pt 5, Ch 12 Piping Design Requirements*.

2.2 Equipment – Selection and installation

2.2.1 Pressure vessels in provision store and air-conditioning refrigeration systems are to be in accordance with *Pt 5, Ch 11 Other Pressure Vessels*.

2.2.2 Valves and flexible hose lengths are to comply with the relevant requirements of *Pt 5, Ch 12 Piping Design Requirements*.

2.2.3 Pipes in piping systems are to be permanent pipes made with approved pipe connections to enable ready removal of valves, pumps, fittings and equipment. The pipes are to be efficiently secured in position to prevent chafing or lateral movement.

2.2.4 Suitable means for expansion are to be made, where necessary, in each range of pipes.

2.2.5 Suitable protection is to be provided for all pipes and equipment situated where they are liable to mechanical damage.

2.2.6 All moving parts are to be provided with guards to minimise danger to personnel.

2.2.7 Primary refrigerant pipework, serving AHUs and FCUs, which pass through bulkheads and deckheads is to comply with the requirements of SOLAS Chapter II-2, 3 *Penetrations in fire-resisting divisions and prevention of heat transmission*.

2.3 Valves and relief devices

2.3.1 Valves are to be fitted in places where they are readily accessible at all times.

2.3.2 Relief valves are to be adjusted and bursting discs so selected that they relieve at a pressure not greater than the design pressure of the system. When satisfactorily adjusted, relief valves are to be protected against tampering or interference by a locking wire with a lead seal or similar arrangement, see also *Pt 7, Ch 15, 2.4 Refrigerant systems 2.4.4*.

2.4 Refrigerant systems

2.4.1 The primary refrigerants ammonia, hydrocarbons or carbon dioxide shall not be used in direct expansion FCUs located in accommodation spaces. The use of these refrigerants in machinery spaces, such as a separate AHU compartment, may be accepted subject to suitable safety arrangements being provided to the satisfaction of Lloyd's Register (hereinafter referred to as LR).

2.4.2 Compartments containing refrigeration plant are to be provided with refrigerant gas leak detectors with an alarm. See *Pt 7, Ch 15, 4 Refrigerant detection systems*.

2.4.3 The design of refrigeration systems is to permit maintenance and repair without unavoidable loss of refrigerant to atmosphere. To minimise refrigerant release to the atmosphere, refrigerant recovery units are to be provided to allow evacuation of a system prior to maintenance.

2.4.4 Refrigeration systems are to be provided with relief devices which are arranged with sufficient margins to avoid circumstances that would allow an inadvertent discharge of refrigerant to the atmosphere. The system is to be so designed that overpressure due to fire conditions can be safely relieved.

2.4.5 A pressure relief valve and/or bursting disc is to be fitted between each positive displacement compressor and its gas delivery stop valve, the discharge being led to the suction side of the compressor. The refrigerant flow capacity of the valve or disc is to exceed the full load compressor capacity for the particular refrigerant at the maximum potential suction pressure. For these internal relief valves, servo-operated valves will be accepted. Where the motive power for the compressor does not exceed 10 kW, the pressure relief valve and/or bursting disc may be omitted.

2.4.6 Each pressure vessel which may contain liquid refrigerant and which is capable of being isolated by means of a stop or automatic control or check valve is to be protected by two pressure relief valves or two bursting discs, or one of each, controlled by a changeover device. Pressure vessels that are connected by pipework without valves, so that they cannot be isolated from each other, may be regarded as a single pressure vessel for this purpose, provided that the interconnecting pipework does not prevent effective venting of any pressure vessel.

2.4.7 Omission of one of the specified relief devices and changeover device, as required by *Pt 7, Ch 15, 2.4 Refrigerant systems 2.4.6*, will be accepted where:

Refrigeration Systems and Equipment Serving Provision Stores and Air-Conditioning Installations

Part 7, Chapter 15

Section 2

- (a) vessels are of less than 300 litres internal gross volume; or
- (b) vessels discharge into the low pressure side of the system by means of a relief valve.

2.4.8 Sections of systems and components that could become full of liquid between closed valves are to be provided with pressure relief devices relieving to a suitable point in the refrigerant circuit.

2.4.9 Where any hermetic or semi-hermetic compressor has the electric motor cooled by the circulating refrigerant, the following arrangements are to be provided:

- (a) Refrigeration circuits are to contain no more than one hermetic or semi-hermetic compressors.
- (b) Each compressor motor is to be fitted with a thermal cutout device to protect the motor against overheating.
- (c) Each refrigerant circuit is to contain a suitable arrangement to allow debris or contaminants from a motor failure to be removed.
- (d) The pressure envelope of any hermetic or semi-hermetic compressor exposed to the refrigerant pressure is to be designed and constructed in accordance with the requirements of *Pt 5, Ch 11 Other Pressure Vessels* and *Pt 5, Ch 17 Requirements for Fusion Welding of Pressure Vessels and Piping* as applicable. Plans are to be submitted for consideration as required by *Pt 5, Ch 11, 1.6 Plans*.

2.5 Air handling unit(s) (AHUs) for air-conditioning systems

2.5.1 Evaporator coils as fitted to direct expansion AHUs are to be considered for approval and plans are to be submitted, *see also Pt 7, Ch 15, 1.2 Plans and information 1.2.2*. All other equipment fitted to an AHU, such as air filtration, dehumidification, heating and humidification systems are outside the scope of these Rules and are the responsibility of the Shipyard and Owner.

2.5.2 Each AHU is to be provided with suitable drip trays and drainage arrangements to remove any condensate which may form.

2.5.3 The installation arrangements of AHUs are to be such as to allow sufficient space for the withdrawal and replacement of the refrigerant cooling coil.

2.6 Air coolers and cooling grids for provision store refrigeration systems

2.6.1 Air cooler fan motors are to be suitably enclosed to withstand the effects of moisture.

2.6.2 Means are to be provided for effectively defrosting air coolers. Air coolers are to be provided with trays of suitable depth arranged to collect all condensate. The trays are to be provided with drains at their lowest points to enable the condensate to be drained away when the refrigerated spaces are in service. When a store operates at temperatures at, or lower than 0°C, provision is to be made for the prevention of freezing of the condensate.

2.6.3 The installation arrangements of air coolers are to be such that when the refrigerated spaces are loaded with provisions, adequate space is provided for the inspection, servicing and renewal of controls, valves, fans and fan motors.

2.6.4 Steel air cooler circuits and cooling grids are to be suitably protected against external corrosion.

2.7 Design pressures

2.7.1 The design pressure of the system will be regarded as equal to its maximum working pressure, *see Pt 7, Ch 15, 2.7 Design pressures 2.7.5*.

2.7.2 The maximum working pressure is the maximum permissible pressure within the system (or part system) in operation or at rest. No pressure relief valve or other protective device is to be set to a pressure higher than the maximum working pressure.

2.7.3 The design pressure of the low pressure side of the system is to be the saturated vapour pressure of the refrigerant at plus 46°C. Due regard is to be taken of defrosting arrangements which may cause a higher pressure to be imposed on the low pressure side of the system. For carbon dioxide design pressures, *see Pt 7, Ch 15, 2.7 Design pressures 2.7.6*.

2.7.4 The minimum design pressure of the high pressure side of the system (P_{dh}), is to be determined from $1,11 \times P_b$, where P_b is an allowance for the compressor high pressure cut-out. P_b is to be not less than to $1,11 \times P_a$, where P_a is the condenser working pressure, when operating in tropical zones and equates to the saturation pressure of the refrigerant at plus 46°C.

2.7.5 Design pressures applicable to refrigerants are to be not less than the values given in *Table 15.2.1 Design pressure limits* when condensers are sea-water cooled. The design pressure for other refrigerants and condensing arrangements is to be agreed with LR.

Refrigeration Systems and Equipment Serving Provision Stores and Air-Conditioning Installations

Part 7, Chapter 15

Section 2

Table 15.2.1 Design pressure limits

Refrigerant	Pressure, (bar g)	
	High	Low
R-717	21,2	17,2
R-22	20,6	16,7
R-290	18,1	14,7
R-600a	6,4	5,2
R-134a	13,4	10,9
R-407C	23,5	19,0
R-410A	34,5	28,0
R-507A	25,3	20,5
R-404A	24,8	20,1
R-744	See Pt 7, Ch 15, 2.7 Design pressures 2.7.6	
<p>Note In view of increasing world-wide restrictive legislation and phasing out of the HCFC refrigerant R-22, it is recommended that this refrigerant should not be used in new installations.</p>		

2.7.6 The proposed design pressure for a carbon dioxide system is to be stated, taking account of the maximum working pressure and the maximum pressure at rest conditions. Where the maximum pressure at rest condition is maintained by the fitting of a supplementary refrigeration unit, condensing the vapour in a holding vessel, supporting calculation is to be provided to show that this can be undertaken with a local ambient temperature of 45°C. The holding vessel is to be thermally insulated to prevent the operation of the relief devices within a 24 hour period after stopping the supplementary refrigeration unit at an ambient temperature of 45°C and an initial pressure equal to the starting pressure of the refrigeration unit.

2.7.7 Where a carbon dioxide system is designed for hot gas defrosting, due regard is to be given to the possibility of a higher pressure being imposed on the low pressure system. The design pressure for the hot gas defrosting section of the system is to be 10 per cent greater than the maximum pressure experienced during defrosting.

2.8 Insulation materials

2.8.1 Where applicable, having regard to their location and environmental conditions, insulation arrangements are to have:

- (a) materials suitably resistant to fire;
- (b) insulation lining suitably resistant to flame spread;
- (c) effective protection against penetration of water vapour; and
- (d) adequate protection against mechanical damage.

2.8.2 The potential for smoke generation and toxicity of insulation materials is to be in accordance with SOLAS Chapter II-2, Part B, *Regulation 6 - Smoke generation potential and toxicity*.

2.8.3 Where the *in situ* foam type of insulation is proposed, full details of the process are to be submitted.

2.8.4 Prefabricated panel systems are to be fitted with suitable pressure equalising devices.

2.8.5 All low temperature pipework, valves and fittings are to be provided with suitable thermal insulation. See Pt 6, Ch 3, 4.11 *Piping systems 4.11.10*.

2.9 Manufacture and certification

2.9.1 Pressure vessels satisfying the conditions listed in Pt 5, Ch 11, 1.6 *Plans 1.6.1* are to be constructed in accordance with the requirements of Pt 5, Ch 11 *Other Pressure Vessels* and Pt 5, Ch 17 *Requirements for Fusion Welding of Pressure Vessels and Piping*. Plans are to be submitted for consideration as required by Pt 5, Ch 11, 1.6 *Plans*.

Refrigeration Systems and Equipment Serving Provision Stores and Air-Conditioning Installations

Part 7, Chapter 15

Section 3

2.9.2 Other equipment, apart from applicable pressure vessels and heat exchangers, used for air-conditioning or provision stores refrigeration systems are not required to be constructed under survey.

2.9.3 All major items of equipment, containing refrigerant, such as compressors, condensers, AHU cooling coils and FCUs shall be supplied with a manufacturer's works certificate providing details of the design and test pressures.

Section 3 Refrigerating machinery and refrigerant storage compartment arrangements

3.1 General

3.1.1 Refrigerating machinery is to be installed in a well ventilated compartment. In general, the arrangements are to be such that all components of the refrigerating machinery can be readily opened up for inspection or replacement. Space is to be provided for the withdrawal and renewal of the tubes in 'shell-and-tube' type evaporators (secondary refrigerant coolers) and condensers. Proposals for alternative arrangements are to be submitted to LR for consideration.

3.1.2 Refrigerating machinery using toxic and/or flammable refrigerants is to be located outside the main machinery space in a separate gastight compartment.

3.1.3 Where the refrigerating machinery is located in a separate gastight compartment, outside the main machinery space, this compartment is to be equipped with effective mechanical ventilation to provide 30 air changes per hour based upon the total volume of the space. The mechanical ventilation system is to have two methods of control, one of which is to be operable from outside the compartment.

3.1.4 Openings for pipes, electrical cables and other fittings in bulkheads and decks are to be fitted with gastight seals.

3.2 Gas storage compartments

3.2.1 Portable steel cylinders containing reserve supplies of refrigerant are to be stored in a well ventilated compartment reserved solely for this purpose.

3.2.2 The storage compartment is to be provided with a mechanical ventilation system providing 10 air changes per hour.

3.2.3 The storage compartment is to be provided with a suitable vapour detection system, *see Pt 7, Ch 15, 4 Refrigerant detection systems*.

3.2.4 The storage compartment is to be provided with suitable water drainage arrangements not connected with the main machinery spaces.

3.2.5 Steel storage cylinders are to be of an approved type and are to be filled to a level suitable for an ambient temperature of plus 46°C.

3.2.6 The storage compartment is to be provided with racks to facilitate secure stowage of the cylinders.

3.3 Pressure testing at manufacturers' works

3.3.1 Components intended for use with a primary refrigerant are to be subject to pressure testing procedures as detailed in *Table 15.3.1 Test pressure*.

Table 15.3.1 Test pressure

Component	Test pressure, (bar g)	
	Pressure test	Tightness test
(1) Pressure vessels	<i>See Pt 5, Ch 11 Other Pressure Vessels</i>	1,0p
(2) Compressor cylinders/crankcase/casing	1,5p	1,0p
(3) Valves and fittings	2,0p	1,0p

Refrigeration Systems and Equipment Serving Provision Stores and Air-Conditioning Installations

Part 7, Chapter 15

Section 4

(4) Pressure piping, fabricated. headers, air coolers, etc.	1,5p	1,0p
Note p is the design pressure as defined in Pt 7, Ch 15, 2.7 Design pressures.		

3.3.2 Component pressure tests are to be hydraulic or where suitable safety measures are taken, may be pneumatic. The latter is to be carried out with a suitable dry inert gas.

3.3.3 Component tightness tests are to be carried out only after completion of satisfactory pressure tests. Pneumatic pressure is to be applied using a suitable dry inert gas.

3.3.4 Components for use with a secondary refrigerant or cooling water are to be hydraulically tested to 1,5 times the design pressure which, in no case is to be less than 3,5 bar g.

3.4 Pressure test after installation on board ship

3.4.1 For primary refrigerant piping welded in place, pressure tests of the welds are to be carried out at a test pressure of 1,5p. This will normally take the form of a pneumatic test (see Pt 7, Ch 15, 3.4 Pressure test after installation on board ship 3.4.2) since hydraulic testing media such as water are not acceptable due to their incompatibility with the primary refrigerants and the difficulty of removing all traces from a completed system.

3.4.2 Pneumatic pressure tests are to be carried out using a suitable inert gas.

Note Where pneumatic testing is used, adequate safety precautions recognising the hazards involved should be observed to prevent danger to personnel and to minimise risk to property.

3.4.3 Where pneumatic tests are prohibited by relevant authorities, the tests required by Pt 7, Ch 15, 3.4 Pressure test after installation on board ship 3.4.1 and Pt 7, Ch 15, 3.4 Pressure test after installation on board ship 3.4.2 may be omitted provided non-destructive examination has been carried out by an approved operator to the satisfaction of LR and in accordance with the requirements of Pt 5, Ch 17, 6 Non-Destructive Examination.

3.4.4 After completion of the test required by Pt 7, Ch 15, 3.4 Pressure test after installation on board ship 3.4.1, Pt 7, Ch 15, 3.4 Pressure test after installation on board ship 3.4.2 or Pt 7, Ch 15, 3.4 Pressure test after installation on board ship 3.4.3, a tightness test is to be carried out using a suitable inert gas at a pressure equal to the design pressure, in the presence of the surveyor.

3.4.5 Secondary refrigerant piping welded in place is to be hydraulically tested to 1,5 times the design pressure which, in no case is to be less than 3,5 bar g.

Section 4 Refrigerant detection systems

4.1 General

4.1.1 A fixed refrigerant detection system is to be provided in the refrigerating machinery compartment or space and ventilation outlet ducts when the ventilation system is shared with other compartments.

4.1.2 The alarm system is to comply with the requirements of Pt 6, Ch 1 Control Engineering Systems and, as a minimum requirement, the system is to activate at a low-level concentration to give warning of refrigerant leaks, and at a high-level concentration corresponding to the refrigerant's safe occupational level.

4.1.3 Detection equipment is to be so designed that it may be readily tested and calibrated; any failure of the equipment is to initiate an alarm.

4.1.4 The location of the detectors is to be determined relative to the layouts of the individual compartments and machinery spaces and are to be indicated in the plan submission.

4.1.5 Audible and visual alarms are to be activated, located both inside and outside the affected space. The alarms are to be readily identifiable and be visible and audible in all locations within the space housing the refrigeration equipment.

Refrigeration Systems and Equipment Serving Provision Stores and Air-Conditioning Installations

Part 7, Chapter 15

Section 5

■ Section 5

Control and monitoring and electrical power arrangements

5.1 General

- 5.1.1 Control engineering arrangements are to comply with *Pt 6, Ch 1 Control Engineering Systems* as applicable.
- 5.1.2 All cooling and secondary refrigerant pumps are to be provided with an indication of discharge pressure and a low discharge pressure alarm at each control station.
- 5.1.3 The power to all independently driven ventilation fans is to be capable of being stopped from position(s) outside the fire boundary which will remain readily accessible in the event of fire occurring in any space, as well as from the local control panel.
- 5.1.4 Electrical engineering arrangements are to comply with *Pt 6, Ch 2 Electrical Engineering*.
- 5.1.5 Refrigeration compressors are to be provided with the following instrumentation and automatic shutdowns:
- Indication of suction pressure (saturated temperature), including intermediate stage when applicable.
 - Indication of discharge pressure (saturated temperature), including intermediate stage when applicable.
 - Indication of lubricating oil pressure.
 - Indication of cumulative running hours (screw compressors).
 - Automatic shutdown in the event of low lubricating oil pressure.
 - Automatic shutdown in the event of high discharge pressure, see also *Pt 7, Ch 15, 5.1 General 5.1.13*.
 - Automatic shutdown in the event of low suction pressure.
- 5.1.6 For refrigeration compressors greater than 25 kW, the following instrumentation, additional to that required by *Pt 7, Ch 15, 5.1 General 5.1.5*, is to be provided:
- Indication of lubricating oil temperature.
 - Indication of condenser cooling water outlet temperature.
 - Indication of cumulative running hours (reciprocating compressors).
 - Indication of suction and discharge temperatures.
- 5.1.7 Alarms are to be initiated in the event of the following fault conditions with refrigeration compressors:
- High discharge pressure.
 - Low suction pressure.
 - Low oil pressure.
 - High discharge temperature.
 - High oil temperature.
 - Motor shutdown.
- 5.1.8 Refrigeration plants are to be provided with the following alarms as applicable:
- Failure of condenser cooling water pumps.
 - High condenser cooling water outlet temperature.
 - Failure of air cooler fans.
 - High and low refrigerated air delivery temperatures.
 - High secondary refrigerant temperatures.
 - Failure of secondary refrigerant pump.
 - Low level in secondary refrigerant header tank.
- 5.1.9 Where the air-conditioning/refrigerating system is fitted with automatic or remote controls, so that, under normal operating conditions, no manual intervention by the operators is required, it is to be provided with the alarms required by *Pt 7, Ch 15, 5.1 General 5.1.6* to *Pt 7, Ch 15, 5.1 General 5.1.8* in accordance with the relevant requirements of *Pt 6, Ch 1 Control Engineering Systems*.
- 5.1.10 Where more than one compressor is fitted, the control sequence is to be such as to allow one machine to stop in the event of a reduction in cooling duty. Provision is to be made to allow selection of the lead machine to equalise running hours.

Refrigeration Systems and Equipment Serving Provision Stores and Air-Conditioning Installations

Part 7, Chapter 15

Section 6

5.1.11 To allow the equipment to be isolated from the power supply in the event of a failure or refrigerant leak, refrigeration compressors and AHUs are to be fitted with local emergency stop switches.

5.1.12 AHUs are to be provided with the following instrumentation as a minimum:

- (a) Indication of primary refrigerant outlet pressure and temperature; and
- (b) Indication of outlet air temperature.

5.1.13 Compressors are to be provided with automatic shutdown in the event of high discharge pressure. For refrigeration systems where the maximum working pressure is less than or equal to 40 bar g, the automatic shutdown is to operate at a pressure in excess of normal operating pressure but no greater than 0,9 of the maximum working pressure. For refrigeration systems where the maximum working pressure is greater than 40 bar g, the automatic shutdown is to operate at a pressure in excess of normal operating pressure but no greater than 0,95 of the maximum working pressure.

Section 6

Personnel safety equipment and systems

6.1 Personnel safety equipment

6.1.1 Access doors to the refrigerated spaces are to open outwards, alternatively sliding doors may be used where the door is external to the space.

6.1.2 Access ways to the refrigerated spaces are to be designed to facilitate escape in emergencies, and the removal of stretcher-borne personnel.

6.1.3 Access ways and refrigerated compartments are to be provided with an independent lighting system in accordance with the requirements of *Pt 6, Ch 2, 5.7 Lighting circuits 5.7.2* and *Pt 6, Ch 2, 5.7 Lighting circuits 5.7.4*, with the means of locking the switches in the 'on' position.

6.1.4 Arrangements are to be such that means are provided for both opening the room door(s) and sounding the alarm required by *Pt 7, Ch 15, 6.2 Personnel warning systems 6.2.2* from inside refrigerated spaces.

6.1.5 Where ammonia is used in refrigerating systems, the following items of safety equipment are to be provided as a minimum, and positioned in accessible protected storage (e.g. locked glass fronted cabinets) located outside the machinery compartment:

- (a) Two sets of ammonia protective clothing (including helmet, boots and gloves).
- (b) Two portable battery powered hand lamps (to be of certified safe-type).
- (c) Two sets of self-contained breathing apparatus (compressed air).
- (d) Two full face mask respirators.
- (e) Two fire-resistant life-lines.
- (f) Two firemen's axes.
- (g) Two heavy duty adjustable spanners.
- (h) Two wheel wrenches.
- (i) Irrigation facilities or eye wash bottles containing an eye wash solution, distilled water or non-carbonated mineral water.
- (j) Hand or foot-operated douches providing a copious supply of clean water, located outside the compartment's doors.

6.2 Personnel warning systems

6.2.1 A system to monitor the well-being of crew members entering refrigerated spaces is to be provided.

6.2.2 The system is to be such that at a predetermined time, after initiation, the crew member(s) receives warning that the system is to alarm and must indicate their well-being by accepting the warning.

6.2.3 The system is to be designed and arranged such that only an authorised person has access for enabling and disabling it and setting the appropriate intervals, and such that it cannot be operated in an unauthorised manner.

6.2.4 It is to be possible to acknowledge the warning by means of illuminated switches situated near the access doors or hatches of each refrigerated space or chambers within the space.

Refrigeration Systems and Equipment Serving Provision Stores and Air-Conditioning Installations

Part 7, Chapter 15

Section 7

6.2.5 In the event that the crew member(s) fails to respond and accept the warning within an agreed specified time, the system is to immediately initiate an alarm on the bridge and at the main control station, or subsidiary control stations as appropriate. Manual initiation of the alarm system from the refrigerated spaces is to be possible at any time.

6.2.6 The system is to comply with the relevant requirements of *Pt 6, Ch 1 Control Engineering Systems*.

■ Section 7

Testing and trials

7.1 Testing

7.1.1 The requirements of the Rules relating to testing of pressure vessels, piping and related fittings including hydraulic testing are applicable. See *Pt 5, Ch 11 Other Pressure Vessels* and *Pt 5, Ch 12, 8 Hydraulic tests on pipes and fittings*.

7.1.2 On completion, tanks and reservoirs for service and storage of system fluids are to be tested by a head of water equal to the maximum to which the tanks may be subjected, but not less than 2,5 m above the crown of the tank.

7.1.3 After installation on board, piping systems together with associated fittings that are under internal pressure, are to be subjected to a running test at the intended maximum working pressure.

7.1.4 Testing is to cover the following items:

- (a) Verification of control, alarm and safety systems.
- (b) Simulation tests for failure of refrigeration equipment, to verify correct functioning of alarms and systems in service.
- (c) Verification of accuracy, calibration and functioning of temperature control for refrigeration systems.

7.2 Trials

7.2.1 Acceptance trials, as stipulated in this Section, are to be conducted. It is to be demonstrated that the provision store or air-conditioning refrigerating system capacity meets the design duty. As far as is practicable, the trials are to represent the operating conditions that will be encountered in service. For example, the condenser cooling water flow should be restricted so that the compressor discharge pressure is at the design value.

		CLASSIFICATION
PART	1	REGULATIONS
PART	2	RULES FOR THE MANUFACTURE, TESTING AND CERTIFICATION OF MATERIALS
PART	3	SHIP STRUCTURES (GENERAL)
PART	4	SHIP STRUCTURES (SHIP TYPES)
PART	5	MAIN AND AUXILIARY MACHINERY
PART	6	CONTROL, ELECTRICAL, REFRIGERATION AND FIRE
PART	7	OTHER SHIP TYPES AND SYSTEMS
PART	8	RULES FOR ICE AND COLD OPERATIONS
		CHAPTER 1 APPLICATION
		CHAPTER 2 ICE OPERATIONS - ICE CLASS

Section

- 1 **Scope**
 - 2 **Ice environment**
 - 3 **Air environment**
 - 4 **Icing environment**
-

■ *Section 1*
Scope

1.1 General

- 1.1.1 The following requirements are for ships intended for operations in ice and cold conditions.
- 1.1.2 Guidance on the appropriate requirements and notations is provided in *Table 1.1.1 Ice and cold operations*.

Table 1.1.1 Ice and cold operations

Reference	Conditions	Description	Notation	
Ice Operations				
Chapter 2	Section 1	Application		
	Section 2 Hull Section 3 Machinery	General requirements	Applicable to all ice classes	
	Section 4 Hull Section 5 Machinery	Light and very light ice conditions	For ships with length less than 150 m	Ice Class 1E
			Hull strengthening in forward region only	Ice Class 1D
	Section 6 Hull Section 7 Machinery	First-year ice conditions	<i>Finnish-Swedish Ice Class Rules</i>	Ice Class 1C FS Ice Class 1B FS Ice Class 1A FS Ice Class 1AS FS
	Section 8 Hull Section 9 Machinery		<i>Finnish-Swedish Ice Class Rules</i> with enhanced engine power for icebreaking capability	Ice Class 1C FS(+) Ice Class 1B FS(+) Ice Class 1A FS(+) Ice Class 1AS FS(+)
	Section 10 Hull Section 11 Machinery	Multi-year ice conditions	IACS Polar Ship Rules	Ice Class PC7 Ice Class PC6 Ice Class PC5 Ice Class PC4 Ice Class PC3 Ice Class PC2 Ice Class PC1
	Cold operations			
<i>Provisional Rules for the Winterisation of Ships</i>	Section 1	Application		
	Section 2 Hull materials	Low temperature operations	Hull construction materials	Winterisation H(T)
			Short duration	Winterisation C(T)
	Section 3 Equipment and systems	Low temperature operations	Seasonal duration	Winterisation B(T)
Prolonged duration			Winterisation A(T)	

1.1.3 At the Owner’s request and in order to enhance safety and awareness on board during ship operation, the **ShipRight SEA(ICE) Ship Event Analysis Procedure** may be applied. This procedure may be applied to all ships where it is intended to provide a hull surveillance system for monitoring of the ship’s hull girder stresses and local ice loads when the ship is navigating in ice, and warning the ship’s personnel that the load levels or the frequency and magnitude of ice impacts are approaching a level where corrective action is advisable. See Pt 1, Ch 2, 2.8 Descriptive notes 2.8.3 and Pt 3, Ch 16, 6 Ship Event Analysis.

1.1.4 At the Owner’s request and in order to enhance safety, the **ShipRight FDA ICE Fatigue Induced by Ice Loading Procedure** may be applied. This procedure is supplementary to the FDA procedures and is to assess fatigue damage induced by ice loads for ships navigating in ice-covered regions. The objective of the **ShipRight FDA ICE** procedure is to provide technical

guidelines to assess fatigue at the end connections of stiffeners in the ice belt regions under ice loading. See Pt 1, Ch 2, 2.3 Class notations (hull) 2.3.17 and Pt 3, Ch 16, 4 Fatigue design assessment.

■ **Section 2**
Ice environment

2.1 General

2.1.1 This Section is intended to give assistance on the selection of a suitable ice class notation for the operation of ships in ice-covered regions.

2.1.2 The Owner is to confirm which notation is most suitable for their requirements. Ultimately, the responsibility rests with the master of the ship and their assessment of the ice and temperature conditions at the time.

2.1.3 The documentation supplied to the ship is to contain the ice class notation adopted, any operation limits for the ship and guidance on the type of ice that can be navigated for the nominated ice class.

2.2 Definitions

2.2.1 The World Meteorological Organisation's, WMO, definitions for sea ice thickness are given in *Table 1.2.1 WMO definition of ice conditions*.

Table 1.2.1 WMO definition of ice conditions

Ice conditions	Ice thickness
Medium first-year	1,2 m
Thin first-year, second stage	0,7 m
Thin first-year, first stage	0,5 m
Grey-white	0,3 m
Grey	0,15 m

2.2.2 *Table 1.2.2 Comparison of ice Standards* defines the ice classes in relation to the Rules and the equivalent Internationally Recognised Standards.

Table 1.2.2 Comparison of ice Standards

Lloyd's Register class notation	Finnish-Swedish Ice Class	Canadian type
Ice Class 1AS FS(+) Ice Class IAS FS	IA Super	A
Ice Class 1A FS(+) Ice Class 1A FS	IA	B
Ice Class 1B FS(+) Ice Class 1B FS	IB	C
Ice Class 1C FS(+) Ice Class 1C FS	IC	D

Ice Class 1D	—	D
Ice Class 1E	—	E











2.3 Application

2.3.1 The variable nature of ice conditions is such that the average limits of the conditions are not easily defined. However, it is possible to plot the probable limits of the ice flows and the ice edge for each season. See *Figure 1.2.1 Ice Limits for the Arctic Winter* to *Figure 1.2.4 Ice Limits for the Antarctic Summer*, and *Table 1.2.3 Concentration of ice*.

2.3.2 Operation with **Ice Class 1C FS** may be possible up to 150 nm inside the 7/10 region shown depending on the severity of the winter. Operation with **Ice Class 1A FS** may be possible up to 150 nm inside the medium first-year ice shown depending on the severity of the winter. Operation up to the multi-year ice is possible most years with **Ice Class 1AS FS**.

2.3.3 Operation in the region between 7/10 and 1/10 in the ice-covered regions is possible with due care for ships with no ice class. For ships operating for extended periods in these areas, it will be necessary to specify and design for a minimum temperature for the hull materials. To cover all situations for a non-ice class ship, the material requirements of *The Provisional Rules for the Winterisation of Ships* are recommended.

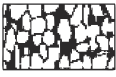
Table 1.2.3 Concentration of ice

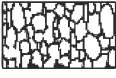
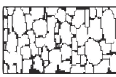
Free ice		0/10		
Open water		<1/10		
Very open drift		1/10	 2/10	 3/10
Open drift		4/10	 5/10	 6/10
Close pack/drift		7/10	 8/10	
Very close pack		9/10	 9+/10	
Compact/consolidated ice		10/10		

2.4 Ice Class notations

2.4.1 Where the requirements of Chapter 2 are complied with, the ship will be eligible for a special features notation as defined in *Pt 1, Ch 2, 2.1 Definitions 2.1.10*, see also *Table 1.1.1 Ice and cold operations*.

2.4.2 In general, an Ice Class Notation contained in this Part of the Rules will only be assigned where the vessel has been assigned a **✳ LMC** notation. A [**✳**] **LMC** notation may be accepted where ice class machinery items are not included within the scope of the propulsion arrangements for acceptance of a manufacturer's certificate, see *Pt 1, Ch 1 General Regulations*.

2.5 National Authority requirements

2.5.1 Certain areas of operation may require compliance or demonstration of equivalence with National Authority requirements. *Table 1.2.2 Comparison of ice Standards* gives the equivalence of National Authority requirements.

2.5.2 The standards of ice strengthening required by the Rules have been accepted by the Finnish and Swedish Boards of Navigation as being such as to warrant assignment of the Ice Classes given in *Table 1.2.2 Comparison of ice Standards*.

2.5.3 Ships intending to navigate in the Canadian Arctic must comply with the *Canadian Arctic Shipping Pollution Prevention Regulations established by the Consolidated Regulations of Canada, 1978, Chapter 353*, in respect of which Lloyd's Register is authorised to issue Arctic Pollution Prevention Certificates.

2.5.4 The Canadian Arctic areas have been divided into zones relative to the severity of the ice conditions experienced and, in addition to geographic boundaries, each zone has seasonal limits affecting the necessary Ice Class notation required to permit operations at a particular time of year. It is the responsibility of the Owner to determine which notation is most suitable for their requirements.

2.5.5 The Canadian Authorities recognise that in the period November 6 to July 31 and any extension to that period declared by the Canadian Coast Guard, oil and bulk chemical tankers which qualify for Canadian Type A, B, C and D as indicated in *Table 1.2.2 Comparison of ice Standards* are suitable for operating in designated ice control zones within Canadian waters, off the east coast of Canada south of 60° north latitude. For all Type E tankers operating in this zone during the specified period, the Canadian Authorities will require either additional hull strength in way of the forward wing cargo tanks port and starboard, or the level of oil or chemical in these tanks to be not higher than one metre below the waterline of the ship in her condition of transit. Where the latter arrangement is adopted, the effect on longitudinal strength is to be considered.

2.5.6 For ships intending to navigate in Finnish-Swedish waters and having a **Polar Ice Class notation**, consideration may need to be given to the installed engine power such that it complies with the applicable *Finnish-Swedish Ice Class Rules, see Pt 8, Ch 2, 7 Machinery requirements for first-year ice conditions – Ice Classes 1AS FS, 1A FS, 1B FS and 1C FS*.

2.6 Ice conditions

2.6.1 Charts and images for the current and recent ice conditions in all areas of the world plus information on icebergs can be found from the National Ice Centre on the world wide web at:

www.natice.noaa.gov

2.6.2 Daily ice information and consultation is available from the Canadian ice service which is part of the Canadian department of the environment. Their web site can be found at:

www.ice-glaces.ec.gc.ca

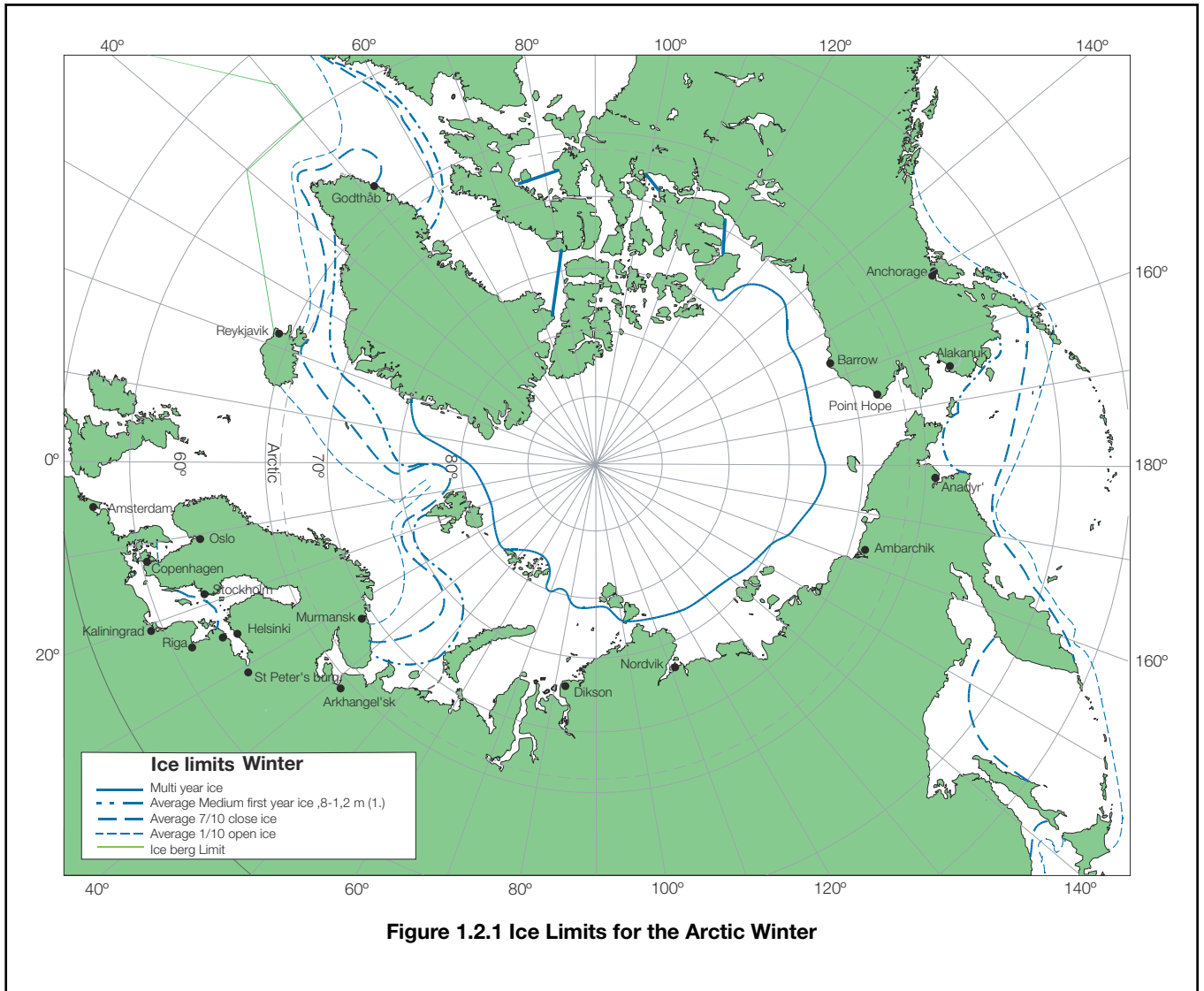

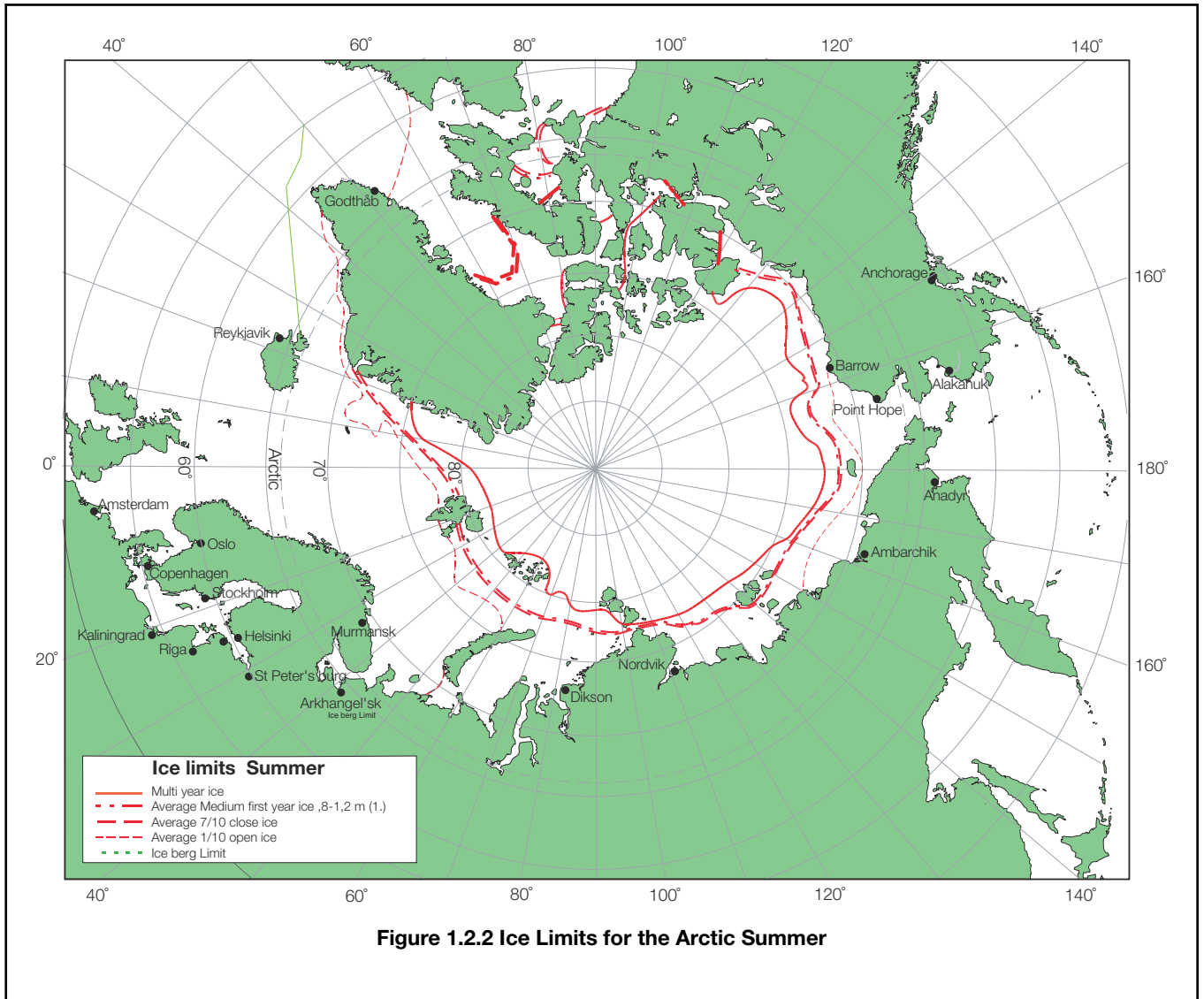

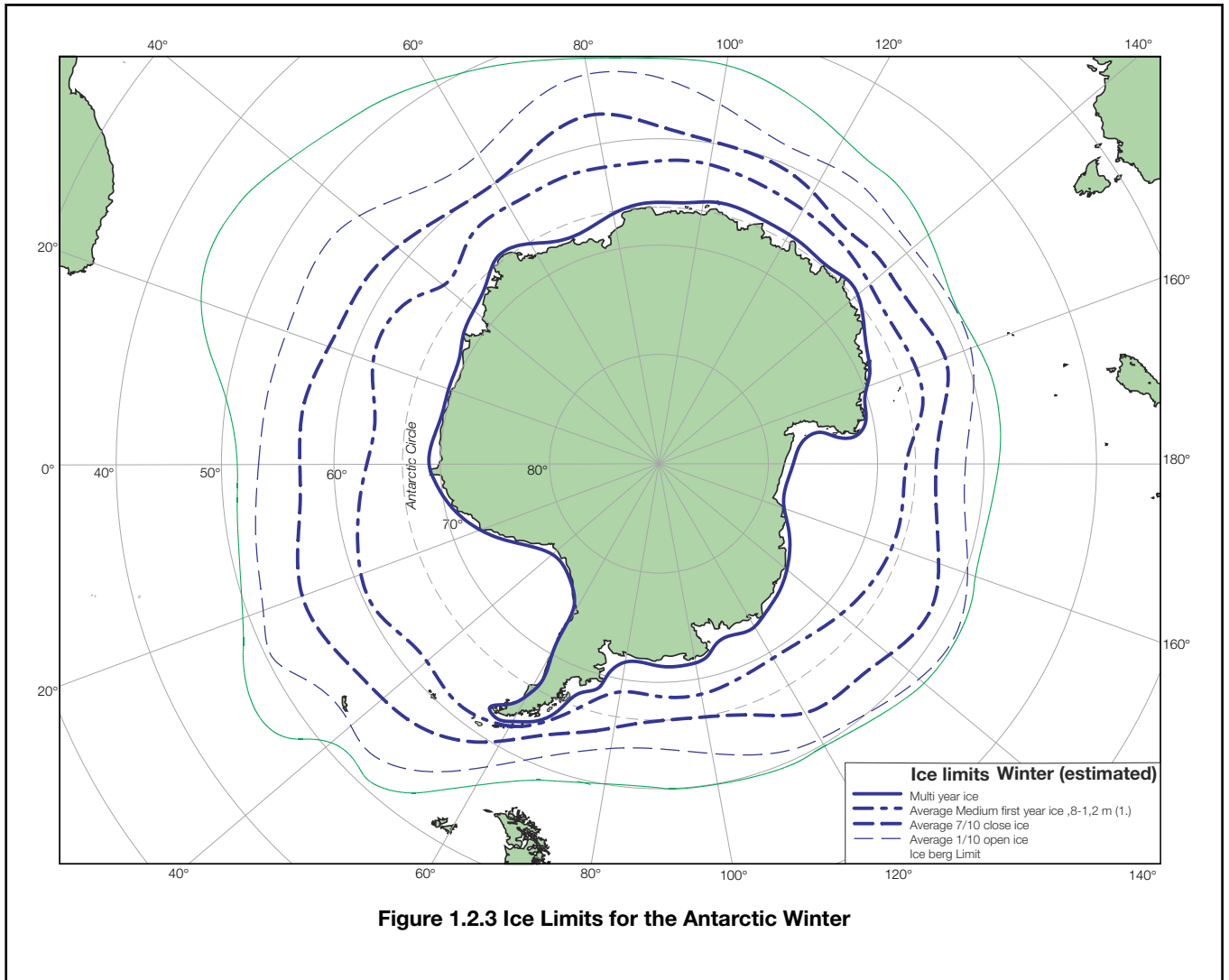

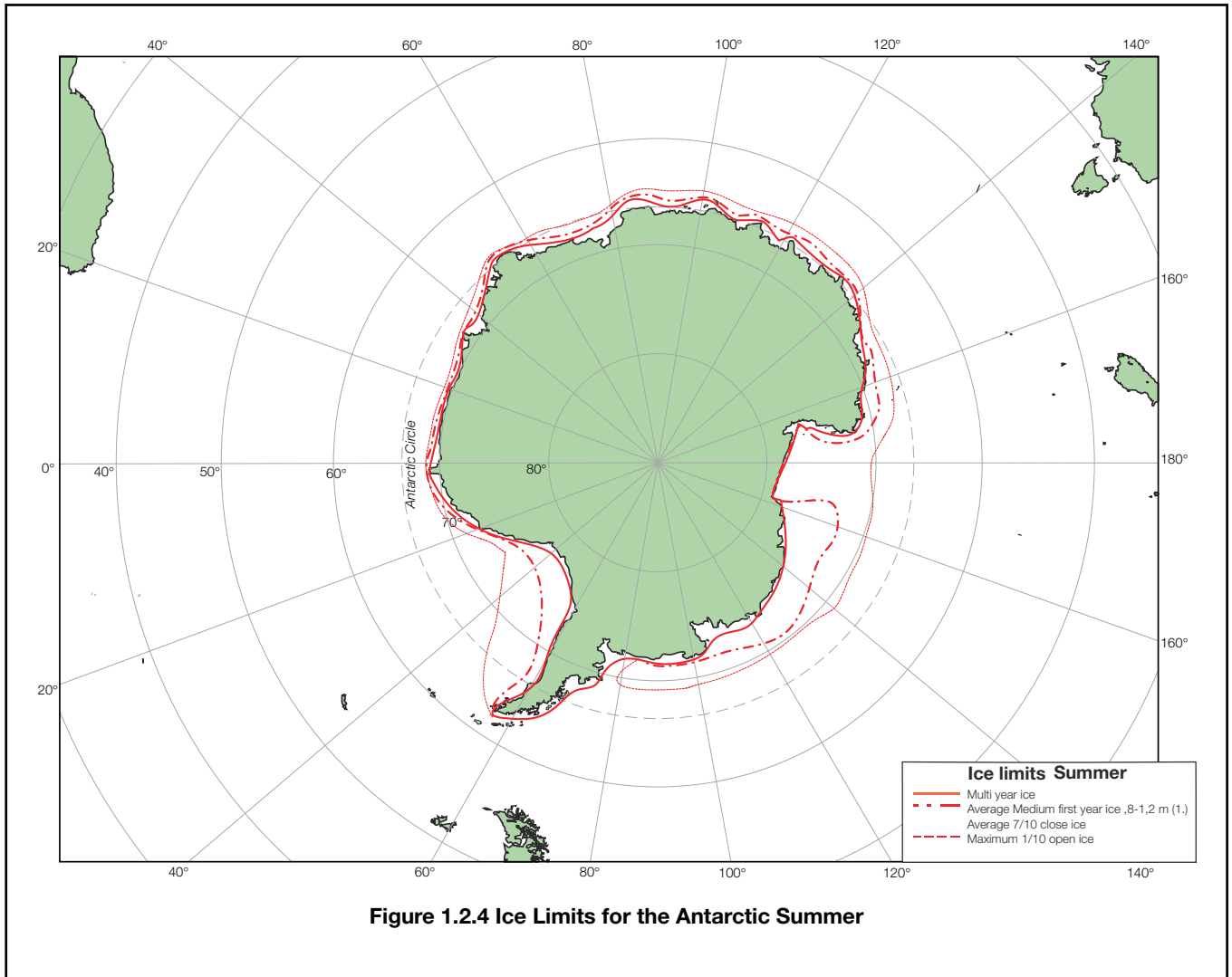

■ **Section 3**
Air environment

3.1 Air temperature

3.1.1 For ships intended to operate in cold regions, the temperature on exposed surfaces is to be considered. See the *Provisional Rules for the Winterisation of Ships, July 2015*

3.1.2 The average external design air temperature is to be taken as the lowest mean daily average air temperature in the area of operation:

where

Mean = statistical mean over a minimum of 20 years

Average = average during one day and one night

Lowest = lowest during the year

MDHT = Mean Daily High Temperature

MDAT = Mean Daily Average Temperature

MDLT = Mean Daily Low Temperature

Figure 1.3.1 Air temperature shows the definition graphically.

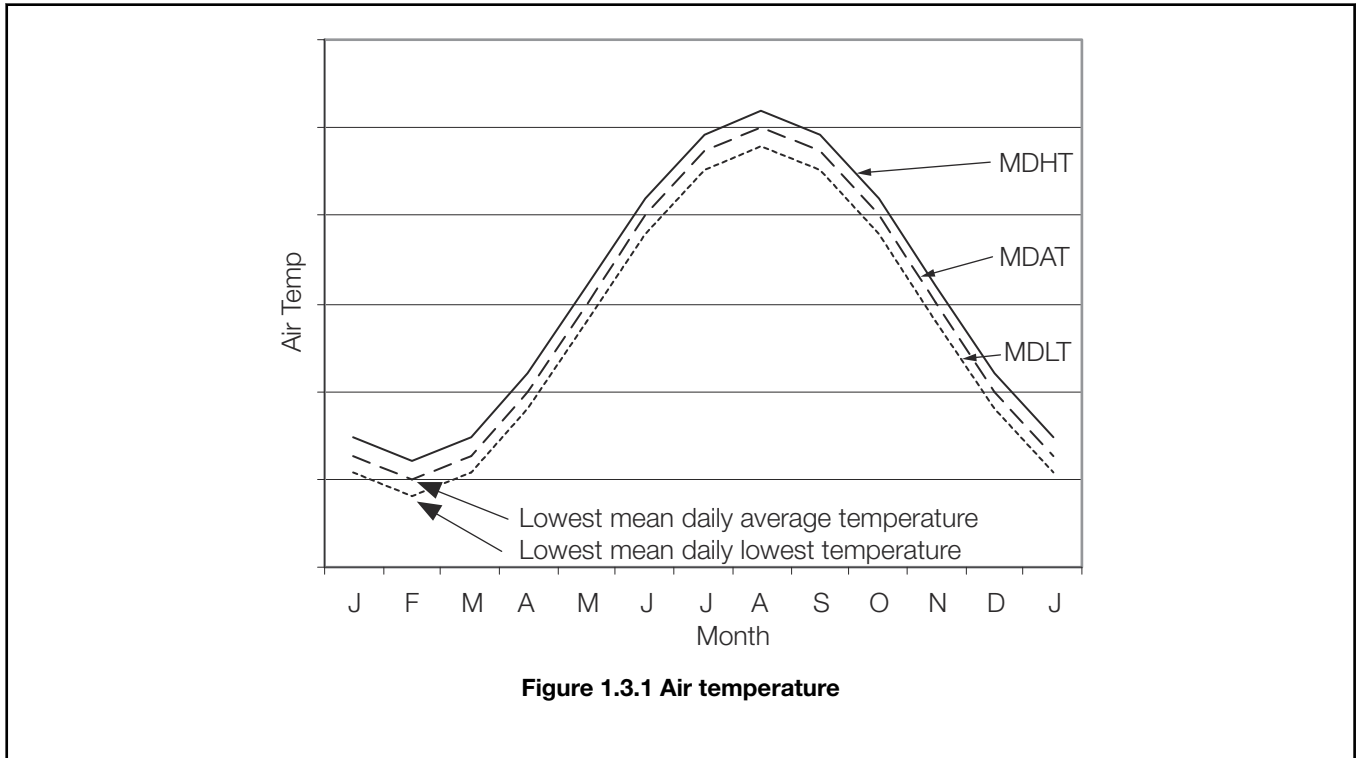

3.1.3 The lowest external design air temperature is to be taken as the lowest mean daily lowest air temperature in the area of operation. Where reliable environmental records for contemplated operational areas exist, the lowest external design air temperature may be obtained after the exclusions of all recorded values having a probability of occurrence of less than 3 per cent.

3.1.4 Lowest mean daily average air temperatures for the Arctic and Antarctic are provided in *Figure 1.3.2 Lowest mean daily air temperatures for the Arctic* and *Figure 1.3.3 Lowest mean daily air temperatures for the Antarctic*.

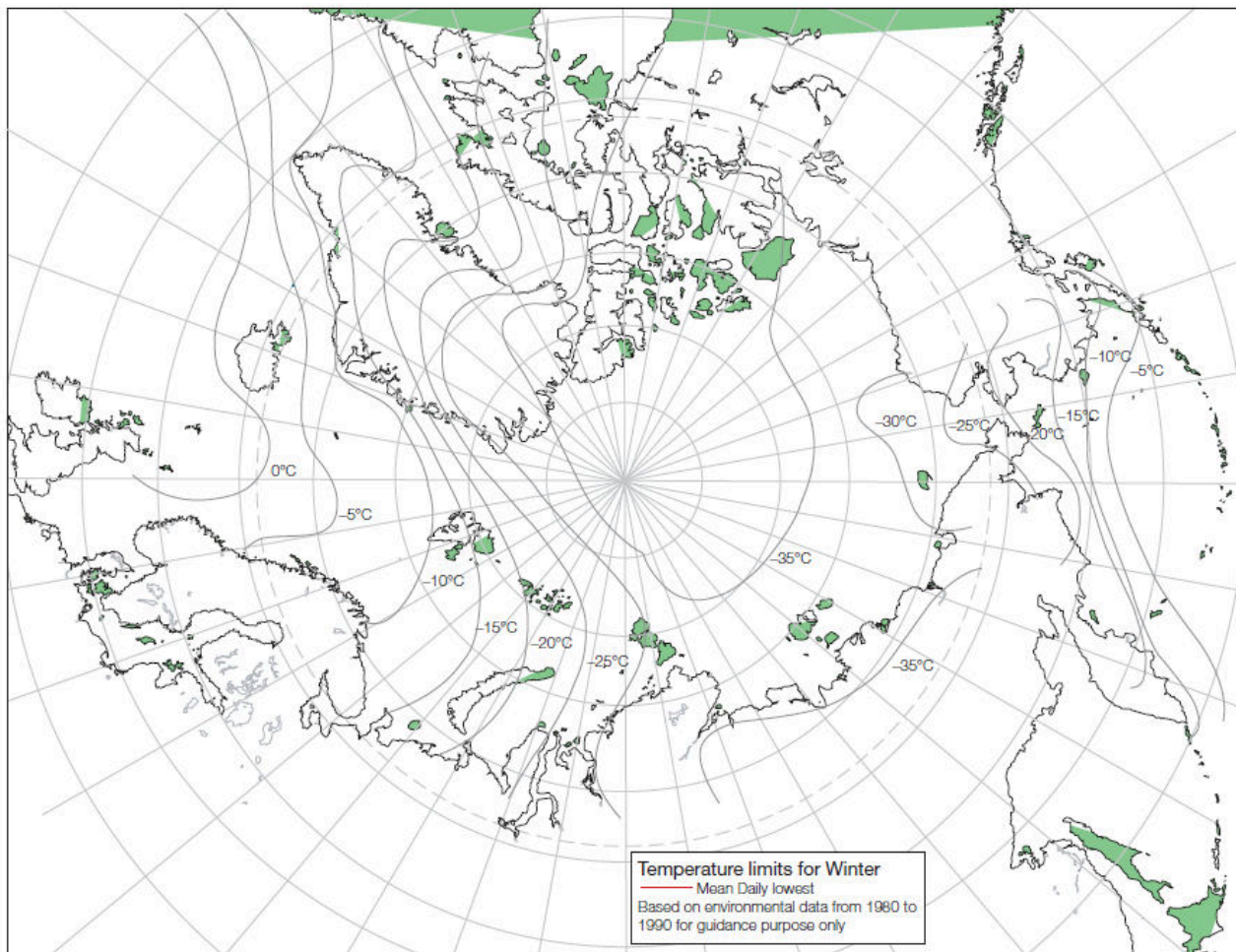

Figure 1.3.2 Lowest mean daily air temperatures for the Arctic

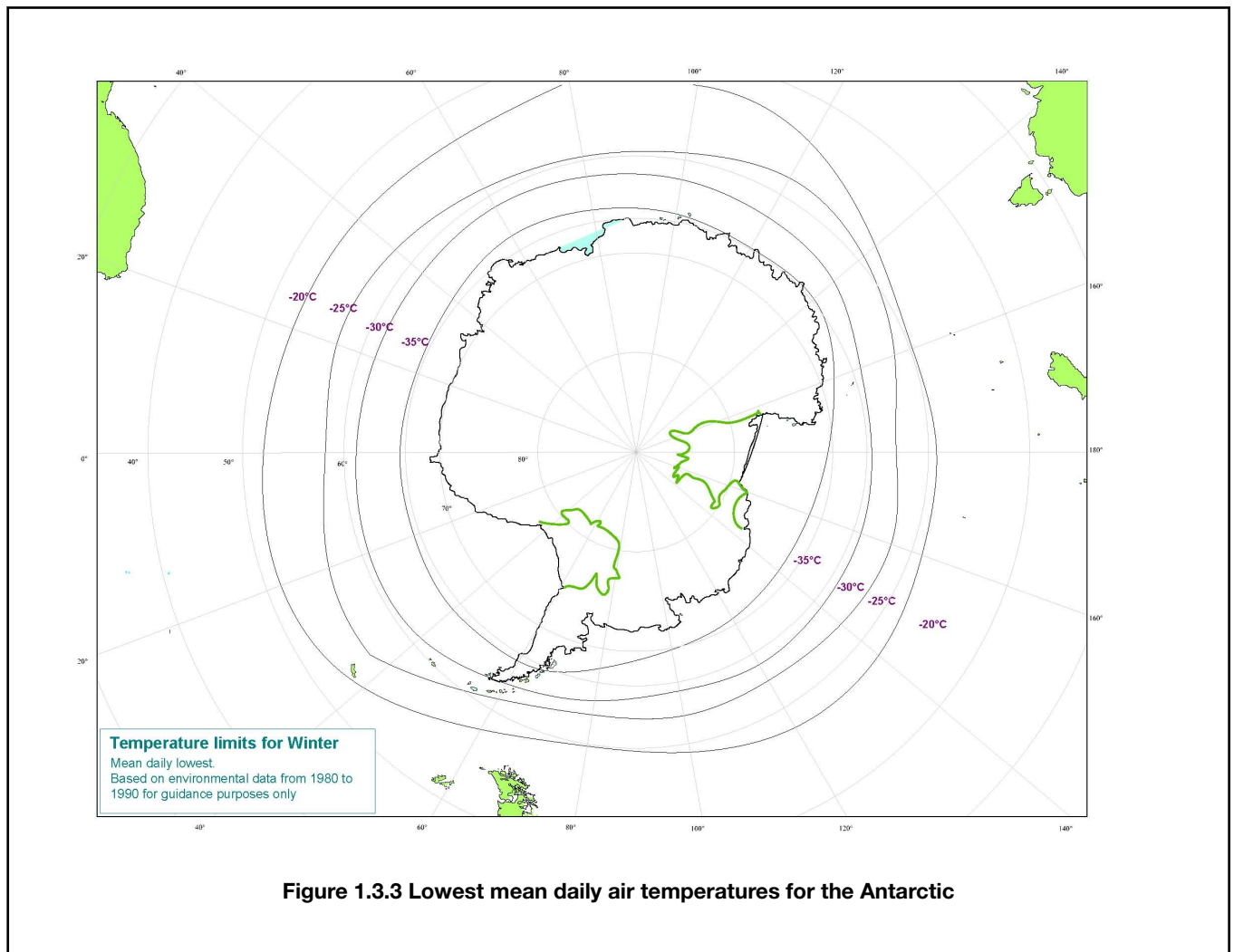

Figure 1.3.3 Lowest mean daily air temperatures for the Antarctic

■ Section 4
Icing environment

4.1 Ice accretion

4.1.1 For ships intended to operate in cold regions, the build up of ice on exposed surfaces is to be considered. See the *Provisional Rules for the Winterisation of Ships, July 2015*.

4.1.2 Icing is to be considered for vessels operating in the following areas, see *Figure 1.4.1 Ice accretion limits for the Arctic* and *Figure 1.4.2 Ice accretion limits for the Antarctic*.

- The area north of latitude 65°30'N, between longitude 28°W and the West coast of Iceland; north of the north coast of Iceland; north of the rhumb line running from latitude 66°N, longitude 15°W to latitude 73°30'N, longitude 15°E, north of latitude 73°30'N between longitude 15°E and 35°E, and east of longitude 35°E, as well as north of latitude 56°N in the Baltic Sea.
- The area north of latitude 43°N bounded in the west by the North American coast and the east by the rhumb line running from latitude 43°N, longitude 48°W to latitude 63°N, longitude 28°W and thence along longitude 28°W.
- All sea areas north of the North American continent west of the areas defined in subparagraphs above.
- The Bering and Okhotsk Seas and the Tartary Strait during the icing season.
- South of latitude 60°S.

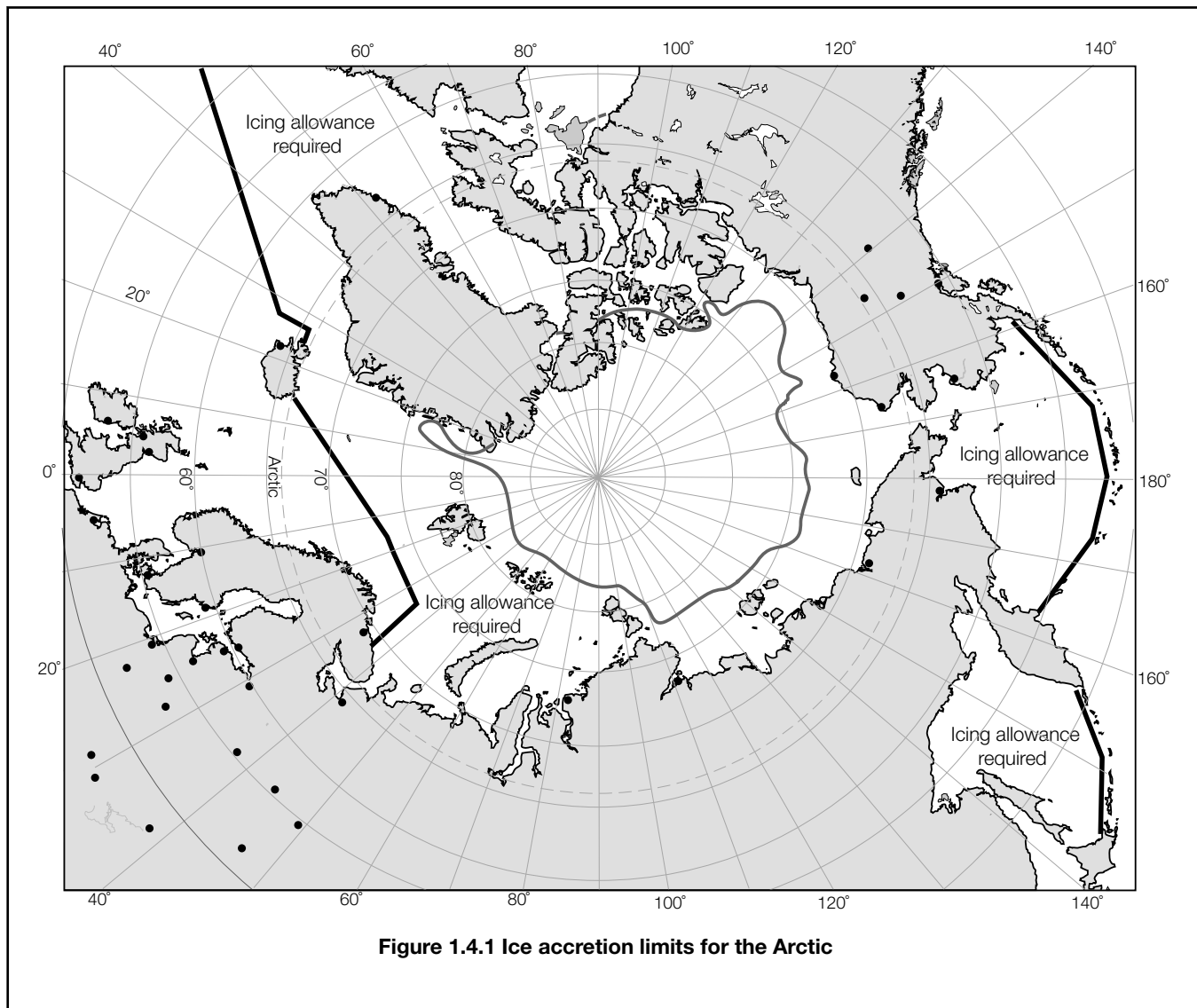

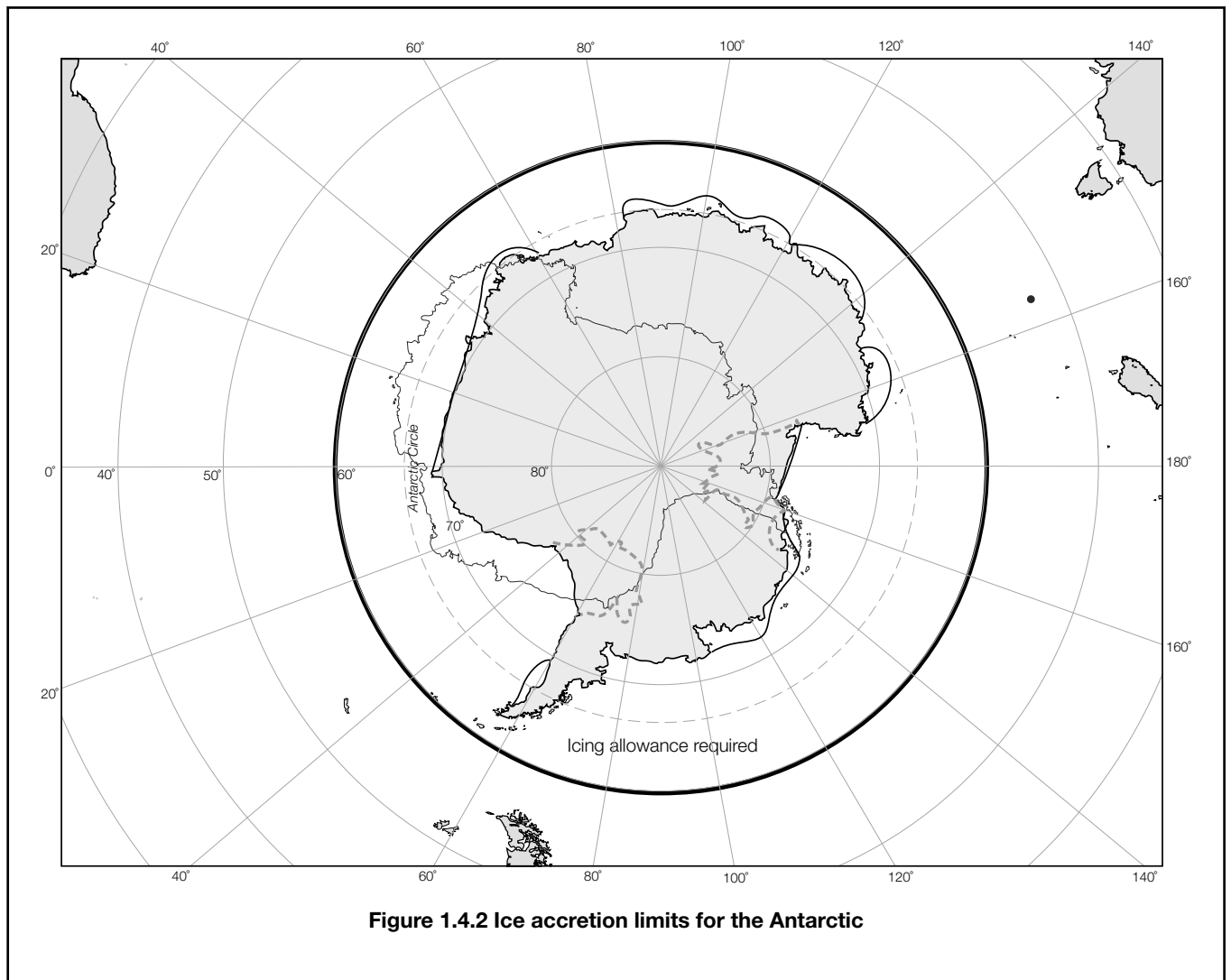

Section

- 1 **Strengthening requirements for navigation in ice – Application of requirements**
- 2 **General hull requirements for navigation in ice – All ice classes**
- 3 **General machinery requirements for navigation in ice – All Ice Classes**
- 4 **Hull requirements for light ice conditions – Ice Classes 1D and 1E**
- 5 **Machinery requirements for light ice conditions – Ice Classes 1D and 1E**
- 6 **Hull requirements for first-year ice conditions – Ice Classes 1AS FS, 1A FS, 1B FS, 1C FS and 1D**
- 7 **Machinery requirements for first-year ice conditions – Ice Classes 1AS FS, 1A FS, 1B FS and 1C FS**
- 8 **Hull requirements for first-year ice conditions – Ice classes 1AS FS(+), 1A FS(+), 1B FS(+) and 1C FS(+)**
- 9 **Machinery requirements for first-year ice conditions - Ice classes 1AS FS(+), 1A FS(+), 1B FS(+) and 1C FS(+)**
- 10 **Hull strengthening requirements for navigation in multi-year ice conditions – Ice Classes PC1, PC2, PC3, PC4, PC5, PC6, PC7 and Icebreaker**
- 11 **Machinery strengthening requirements for navigation in multi-year ice conditions – Ice Classes PC1, PC2, PC3, PC4, PC5, PC6 and PC7**
- 12 **Requirements for Icebreaker(+)**

■ *Section 1* **Strengthening requirements for navigation in ice – Application of requirements**

1.1 Additional strengthening

1.1.1 Where additional strengthening is fitted in accordance with the requirements given in this Chapter, an appropriate special features notation will be assigned. It is the responsibility of the Owner to determine which notation is most suitable for his requirements.

1.1.2 Where a special features notation is desired, the ship is to comply with the requirements of the applicable Sections, in addition to those for sea-going service, so far as they are applicable.

1.1.3 Where the hull and machinery are constructed so as to comply with the requirements of different ice classes, then the assigned Ice Class Notation will be indicated for the combination as the lower of these classes on the Certificate of Class. Any compliance of the hull or machinery with the requirements of a higher ice class will be indicated in square brackets after the main notation. Other supplementary information that would influence the ice performance will also be indicated. For example, a ship hull built in compliance with 1B FS and the machinery in compliance with **1AS FS** would be assigned the Notation **Ice Class 1B FS [1AS FS Machinery]** or **Ice Class 1B FS [1AS FS azimuth thrusters]** where azimuth thrusters are included in the approval.

1.1.4 The vertical extent of the ice strengthening is related to the ice light and ice load waterlines, which are defined in *Pt 8, Ch 2, 2.2 Definitions*. The maximum and minimum draughts at the fore, amidships and aft ends (for the lowest ice class) will be stated on the Certificate of Class.

1.1.5 The installed and required minimum engine output (for the lowest ice class), see *Pt 8, Ch 2, 7 Machinery requirements for first-year ice conditions – Ice Classes 1AS FS, 1A FS, 1B FS and 1C FS*, will be stated on the Certificate of Class.

1.2 Application for light ice conditions

1.2.1 The requirements for **Ice Class IE** are for ships with length less than 150 m and are intended to navigate in very light first-year ice conditions, such as in brash ice and small ice pieces. The requirements of *Pt 8, Ch 2, 4 Hull requirements for light ice conditions – Ice Classes 1D and 1E* and *Pt 8, Ch 2, 5 Machinery requirements for light ice conditions – Ice Classes 1D and 1E* are to be complied with.

1.2.2 The requirements for **Ice Class 1D** are for ships intended to navigate in light first-year ice conditions. The requirements for strengthening the forward region, the rudder and steering arrangements for **Ice Class 1C FS** are applicable.

1.3 Application for first-year ice conditions

1.3.1 Ships that comply with the requirements of the Finnish Swedish Ice Class Rules and *Pt 8, Ch 2, 6 Hull requirements for first-year ice conditions – Ice Classes 1AS FS, 1A FS, 1B FS, 1C FS and 1D* and *Pt 8, Ch 2, 7 Machinery requirements for first-year ice conditions – Ice Classes 1AS FS, 1A FS, 1B FS and 1C FS*, for **Ice Class IA Super, IA, IB** and **IC** may be assigned the corresponding notations **Ice Class 1AS FS, Ice Class 1A FS, Ice Class 1B FS** or **Ice Class 1C FS**. The *Finnish-Swedish Ice Class Rules* may be obtained from the following website:

www.trafi.fi

1.3.2 For ships where the ice class notation **Ice Class 1AS FS(+), Ice Class 1A FS(+), Ice Class 1B FS(+)** or **Ice Class 1C FS(+)** is requested, the requirements of the *Finnish-Swedish Ice Class Rules*, and Sections 8 and 9 are to be complied with.

1.4 Application for multi-year ice conditions

1.4.1 The requirements for strengthening for navigation in ice, as given in *Pt 8, Ch 2, 10 Hull strengthening requirements for navigation in multi-year ice conditions – Ice Classes PC1, PC2, PC3, PC4, PC5, PC6, PC7 and Icebreaker* and *Pt 8, Ch 2, 11 Machinery strengthening requirements for navigation in multi-year ice conditions – Ice Classes PC1, PC2, PC3, PC4, PC5, PC6 and PC7*, are intended for ships operating in multi-year ice in Arctic or Antarctic ice conditions under their own power and constructed of steel, except icebreakers, see *Pt 8, Ch 2, 1.5 Icebreakers 1.5.1*.

1.4.2 Ships that comply with *Pt 8, Ch 2, 10 Hull strengthening requirements for navigation in multi-year ice conditions – Ice Classes PC1, PC2, PC3, PC4, PC5, PC6, PC7 and Icebreaker* and *Pt 8, Ch 2, 11 Machinery strengthening requirements for navigation in multi-year ice conditions – Ice Classes PC1, PC2, PC3, PC4, PC5, PC6 and PC7* can be considered for a Polar Class (**PC**) notation as listed in *Table 2.1.1 Polar class descriptions*.

1.4.3 The Polar Class (**PC**) notations and descriptions are given in *Table 2.1.1 Polar class descriptions*. It is the responsibility of the Owner to select an appropriate Polar Class. The descriptions in *Table 2.1.1 Polar class descriptions* are intended to guide owners, designers and administrations in selecting an appropriate Polar Class to match the requirements for the ship with its intended voyage or service.

1.4.4 The Polar Class notation is used throughout *Pt 8, Ch 2, 10 Hull strengthening requirements for navigation in multi-year ice conditions – Ice Classes PC1, PC2, PC3, PC4, PC5, PC6, PC7 and Icebreaker* and *Pt 8, Ch 2, 11 Machinery strengthening requirements for navigation in multi-year ice conditions – Ice Classes PC1, PC2, PC3, PC4, PC5, PC6 and PC7* to convey the differences between classes with respect to operational capability and strength.

Table 2.1.1 Polar class descriptions

Polar Class	Ice description (based on WMO Sea Ice Nomenclature)
Ice Class PC 1	Year-round operation in all Polar waters
Ice Class PC 2	Year-round operation in moderate multi-year ice conditions
Ice Class PC 3	Year-round operation in second-year ice which may include multi-year ice inclusions
Ice Class PC 4	Year-round operation in thick first-year ice which may include old ice inclusions
Ice Class PC 5	Year-round operation in medium first-year ice which may include old ice inclusions
Ice Class PC 6	Summer/autumn operation in medium first-year ice which may include old ice inclusions
Ice Class PC 7	Summer/autumn operation in thin first-year ice which may include old ice inclusions

1.5 Icebreakers

1.5.1 Sea-going ships specially designed for ice-breaking duties will be assigned the ship type notation '**Icebreaker**' in addition to the special features notation appropriate to the degree of ice strengthening provided. 'Icebreaker' refers to any ship having an operational profile that includes escort or ice management functions, having powering and dimensions that allow it to

undertake aggressive operations in ice-covered waters, and having a class certificate endorsed with this notation. The additional ship type notations may be assigned as follows:

Icebreaker Refers to a ship having an operational profile that includes escort, research or support functions, having powering and dimensions that allow it to undertake aggressive operations in ice-covered waters, see *Pt 8, Ch 2, 10.8 Hull area factors 10.8.4.*

Icebreaker(+) Refers to a ship for which the powering and dimensions of the hull structure and propulsion machinery necessary to undertake the operational profile as determined by selection of a primary function have been assessed, see *Pt 8, Ch 2, 12 Requirements for Icebreaker(+).*

1.6 Loading manual

1.6.1 Sufficient information is to be supplied to the Master of every ship to enable him to arrange loading and ballasting in such a way as to avoid the creation of unacceptable stresses in the ship's structure. The following information is to be included in the vessel's loading manual:

- (a) Upper and lower ice waterline.
- (b) Propeller immersion.
- (c) Indication of whether the vessel is strengthened for icebreaker towing.

■ Section 2

General hull requirements for navigation in ice – All ice classes

2.1 General

2.1.1 The following Sections are to be complied with for all Ice Classes, where applicable. Alternative arrangements to attain similar performance will be specially considered.

2.1.2 The ballast capacity of the ship is to be sufficient to give adequate propeller immersion in all ice navigating conditions without trimming the ship in such a manner that the actual waterline at the bow is below the lower ice waterline.

2.1.3 Fresh water and sea-water ballast tanks, the tops of which are situated above the design ballast waterline and adjacent to the shell, which are intended to be used in ice and cold navigating conditions, are to be provided with means to prevent freezing. Measures are to be provided to demonstrate that they protect against the following:

- (a) hull structural damage from pumping water creating a vacuum beneath a layer of ice across the top of the water in the tank, and
- (b) hull structural damage from ice expansion, and
- (c) engineering systems, such as piping systems and components, damage from ice expansion or ice blockage, and
- (d) engineering systems, such as piping systems and components, damage from ice pieces melting or dislodging from upper sections of the tank.

Heating coils are considered an effective means for tanks entirely above the waterline. Heating coils or other effective means such as continuous circulation, air bubbling and/or tank pressure/engineering systems alarms are considered effective for tanks partially below the waterline. Alternatively, demonstration that the above hazards have been mitigated is to be submitted through theoretical calculations, service experience, experimental tests, or a combination thereof.

2.1.4 These Rules are formulated for both transverse and longitudinal framing systems but it is recommended that, whenever practicable, transverse framing is selected.

2.1.5 These Rules assume that when approaching ice infested waters, the ship's speed will be reduced appropriately. The vertical extent of ice strengthening for ships intended to operate at speeds exceeding 15 knots in areas containing isolated ice floes will be specially considered.

2.1.6 An icebreaking ship is to have a hull form at the fore end adapted to break ice effectively. It is recommended that bulbous bows are not fitted to **Ice Class 1AS** ships.

2.1.7 The stern of an icebreaking ship is to have a form such that broken ice is effectively displaced.

2.1.8 Where it is desired to make provision for short tow operations, the bow area is to be suitably reinforced. Similarly, icebreakers may require local reinforcement in way of the stern fork.

2.1.9 Shell strakes in way of ice strengthening area for plates are to be grade B/AH.

2.1.10 To prevent unintended contact and permit close tow operations, provision of a bow ice knife (plate fitted between stern and bulbous bow) is not recommended for ships intended to navigate with icebreaker escort.

2.2 Definitions

2.2.1 The upper and lower ice waterlines upon which the design of the vessel has been based is to be indicated in the classification certificate. The upper ice waterline (UIWL) is to be defined by the maximum draughts fore, amidships and aft. The lower ice waterline (LIWL) is to be defined by the minimum draughts fore, amidships and aft.

2.2.2 The lower ice waterline is to be determined with due regard to the vessel's ice-going capability in the ballast loading conditions (e.g. propeller submergence).

2.2.3 The upper ice waterline (UIWL) and lower ice waterline (LIWL) are to be indicated on the plans. For navigation in certain geographical areas, the relevant National Authority may require the maximum Ice Class draught to be marked on the ship in a specified manner.

2.2.4 **Displacement** Δ is the displacement at the upper ice waterline (UIWL) when floating in water having a relative density of 1.0. For first-year ice class Rules, the displacement is in tonnes. For multi-year ice class Rules, the displacement is in kilo tonnes.

2.2.5 **Shaft power**, P_0 , is the maximum propulsion shaft power, in kW, for which the machinery is to be classed.

2.3 Rudder and steering arrangements

2.3.1 Rudder stoppers working on the rudder blade or rudder head are to be fitted.

■ Section 3

General machinery requirements for navigation in ice – All Ice Classes

3.1 Materials for shafting

3.1.1 The following Sections are to be complied with for all Ice Classes, where applicable. Alternative arrangements to attain similar performance will be considered.

3.1.2 All components of the main propulsion system are to be of steel or other approved ductile material.

3.2 Materials for propellers

3.2.1 Propellers and propeller blades are to be of cast steel or copper alloys and are to be manufactured, tested and certified in accordance with *Ch 4, 1 General requirements*, *Ch 4, 5 Castings for propellers* and *Ch 9, 1 Castings for propellers* of the Rules for Materials respectively.

3.2.2 For steel propellers, the elongation of the material used is to be not less than 15 per cent for a test piece length of 5d. Charpy impact tests are to be carried out in accordance with the requirements of the *Rules for the Manufacture, Testing and Certification of Materials, July 2015*.

3.2.3 Cast steel load transmitting components of controllable pitch mechanisms are to be manufactured, tested and certified in accordance with the requirements of *Ch 4, 5 Castings for propellers* of the Rules for Materials.

3.2.4 Forged steel load transmitting components of controllable pitch propellers are to be manufactured, tested, and certified in accordance with *Ch 5, 1 General requirements* and *Ch 5, 2 Forgings for ship and other structural applications* of the Rules for Materials. Impact tests are to be carried out at minus 10°C and the average energy value is to be not less than 20 J.

3.2.5 Spheroidal cast iron load transmitting-components of controllable-pitch mechanisms are to be manufactured, tested and certified in accordance with the requirements of *Table 7.3.5 Mechanical properties: special qualities* in *Ch 7, 3 Spheroidal or nodular graphite iron castings* of the Rules for Materials.

3.3 Ship-side valves

3.3.1 The sea inlet and overboard discharge valves which are situated at or below the maximum Load Line, are to be provided with low pressure steam or compressed air connection for clearing purposes, see *Pt 5, Ch 13 Ship Piping Systems*. Provisions need not be applied for the discharge from the main engine and central cooling water system for first-year and multi-year ice classes.

3.3.2 When steam is not available for clearing, it is recommended that arrangements be made for supplying water for machinery cooling purposes by circulating from ballast tank(s) of adequate capacity, preferably situated in the double bottom. Such tank(s) must be used only for storage of water ballast or fresh water.

3.4 Fire pumps in motor ships

3.4.1 In motor ships where clearing steam is not available, fire pumps are to be provided with suction from a suitable sea water inlet which is maintained ice-free at all times.

3.4.2 At least one of the fire pumps is to be connected to a sea chest which is provided with de-icing arrangements.

3.5 Main propulsion and essential auxiliary engines

3.5.1 Sea inlets for the cooling water system are to be provided with arrangements to maintain ice free cooling water arrangements as given by IMO *MSC/Circular.504 – Guidance on Design and Construction of Sea Inlets Under Slush Ice Conditions – (28 April 1989)* or by the *Finnish Swedish Ice Class Rules*. Alternative arrangements will be considered, such as by circulating engine cooling water via designated tanks where heat balance calculations have demonstrated that the engines are capable of operating at their maximum continuous rating.

3.5.2 For electric propulsion systems, the total engine output for propulsion provided by generator sets/central generation system is to be based on the calculation with one set out of action, see *Pt 6, Ch 2, 16 Electric propulsion*.

■ Section 4

Hull requirements for light ice conditions – Ice Classes 1D and 1E

4.1 Ice Class 1D

4.1.1 The requirements for strengthening the forward region for **Ice Class 1C FS** are applicable. See *Pt 8, Ch 2, 6 Hull requirements for first-year ice conditions – Ice Classes 1AS FS, 1A FS, 1B FS, 1C FS and 1D*.

4.2 Ice Class 1E – General

4.2.1 These requirements apply to ships with length less than 150 m and which are intended to operate in very light first-year ice conditions. Where additional strengthening is fitted in accordance with the requirements of this sub-Section, the notation **Ice Class 1E** will be assigned.

4.2.2 The requirements for shell plating need only be applied in the shaded region shown in *Figure 2.4.1 Extent of application of plating requirements*. The requirements for framing need only be applied forward of the flat of side.

4.2.3 For longitudinally framed ships, the scantlings of shell plating and framing are to comply with the requirements of **Ice Class 1C FS** using 0,9 times the ice pressure.

4.2.4 For transversely framed ships, the requirements of *Pt 8, Ch 2, 4.3 Shell plating* are to be applied.

4.2.5 Where the structural requirements of **Ice Class 1C FS** give lesser scantlings than the requirements of this sub-Section, the lesser scantlings may be applied.

4.3 Shell plating

4.3.1 The shell plating thickness within the region shown in *Figure 2.4.1 Extent of application of plating requirements* is not to be less than:

$$t = 21,75s \sqrt{k \left(\frac{BL^2}{110000} + 1 \right) \left(1,3 - \frac{4,2}{(0,26/s + 1,8)^2} \right)} + 2 \text{ mm}$$

where

s = spacing of main frames, in metres

L and B = are defined in *Pt 3, Ch 1, 6.1 Principal particulars*

k = is defined in *Pt 3, Ch 2, 1.2 Steel*.

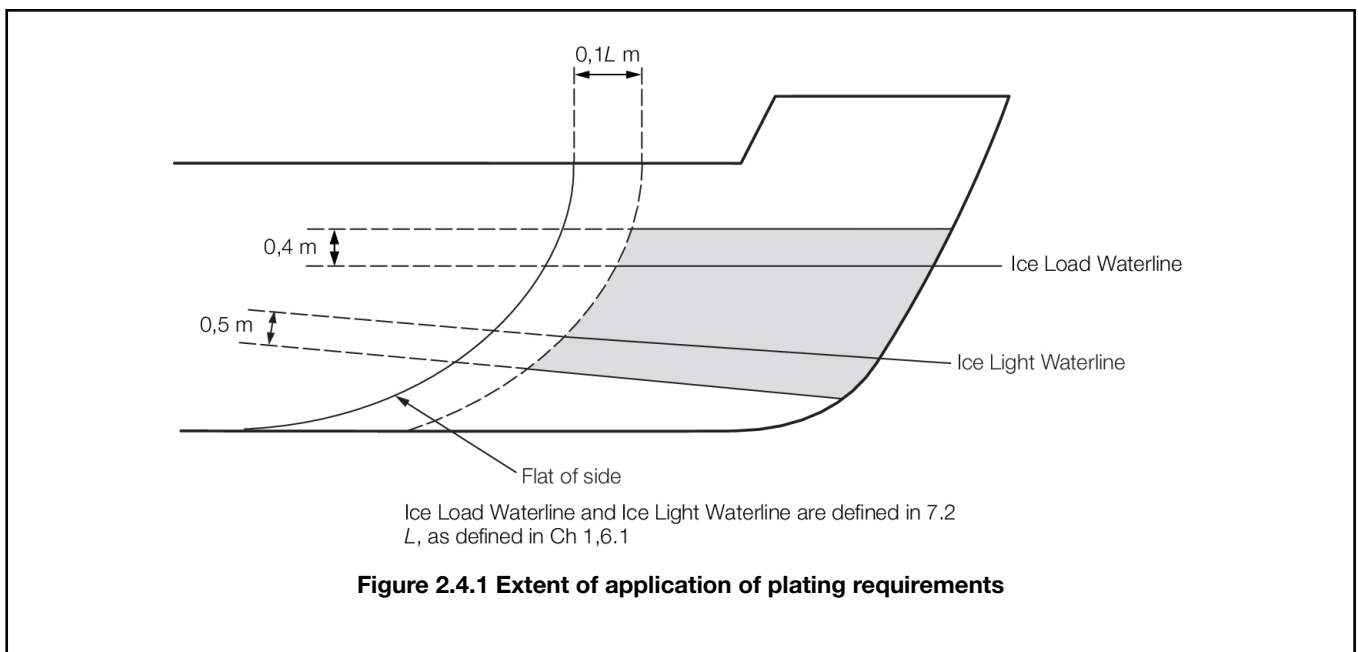

Figure 2.4.1 Extent of application of plating requirements

4.4 Transverse framing

4.4.1 The section modulus of main frames forward of the flat of side is not to be less than:

$$z = 6,08s l k \left(\frac{BL^2}{140000} + 1,23 \right) \left(7 - \frac{1}{2l} \right) \text{ cm}^3$$

but need not be taken as greater than:

$$z = s L T$$

where

s = spacing of main frames, in metres

l = span, in metres

L and B = are defined in *Pt 3, Ch 1, 6.1 Principal particulars*

k = is defined in *Pt 3, Ch 2, 1.2 Steel*.

4.4.2 Intermediate ice frames are to be fitted in the region forward of the flat of side and are to extend from 0,62 m above the upper ice waterline to 1 m below the lower ice waterline.

4.4.3 Intermediate ice frames aft of the collision bulkhead are to have a section modulus not less than 65 per cent of that given in *Pt 8, Ch 2, 4.4 Transverse framing 4.4.1*.

4.4.4 Intermediate ice frames forward of the collision bulkhead are to have a section modulus not less than 40 per cent of that given in *Pt 8, Ch 2, 4.4 Transverse framing 4.4.1*.

4.5 Primary longitudinal members supporting ice frames

4.5.1 Forward of the collision bulkhead, in single deck ships, an ice stringer is to be fitted approximately 0,25 m below the upper ice waterline and is to have scantlings in accordance with *Table 5.4.4 Primary structure forward* in *Pt 3, Ch 5 Fore End Structure*.

4.5.2 Aft of the collision bulkhead a series of tripping brackets are to be fitted at each main and intermediate frame at the same level as the ice stringer to a distance 0,1L aft of the flat of side.

4.6 Stern frame and rudder

4.6.1 The rudder and stern frame scantlings are to be in accordance with *Pt 8, Ch 2, 6.5 Stern*. However, the ship's speed need not be taken as greater than 14 knots. The hull form factor and the rudder profile coefficients are to be taken as 1,0.

4.7 Weld connections

4.7.1 Weld connections to the shell plating forward of the collision bulkhead are to be double continuous.

■ Section 5

Machinery requirements for light ice conditions – Ice Classes 1D and 1E

5.1 General

5.1.1 Where the notation **Ice Class 1D** or **Ice Class 1E** is desired, the requirements of this Section, in addition to those for open water service, are to be complied with.

5.1.2 The requirements need not be taken as greater than those for **Ice Class 1C FS**.

5.2 Engine power

5.2.1 The total engine output is to be not less than determined by the following formula:

$$P = 0,72LB \text{ kW}$$

where

L = Rule length, in metres, see *Pt 3, Ch 1, 6.1 Principal particulars 6.1.1*

B = moulded breadth of ship, in metres, see *Pt 3, Ch 1, 6.1 Principal particulars 6.1.3*.

5.3 Main engine shafting and propellers

5.3.1 The diameters of the shafting and propeller blade thickness as required by the Rules for open water service are to be increased by the percentages as given in *Table 2.5.1 Increase for main engine shafting and propellers*. No increase in the diameter of crankshafts, thrustshafts or intermediate shafts is required.

5.3.2 The screwshaft may be tapered at the forward end in accordance with *Pt 5, Ch 6, 3.5 Screwshafts and tube shafts 3.5.3* and *Pt 5, Ch 6, 3.5 Screwshafts and tube shafts 3.5.4* subject to the increase in diameter of 5 per cent as required by *Pt 8, Ch 2, 5.3 Main engine shafting and propellers 5.3.1*.

Table 2.5.1 Increase for main engine shafting and propellers

Screwshaft, increase in diameter as required by Pt 5, Ch 6, 3.5 Screwshafts and tube shafts	5%
Propeller, increase in blade thickness at root and at 60 per cent radius as required by Pt 5, Ch 7, 3.1 Minimum blade thickness	8%
Keyless propeller fitting, increase in mean torque as defined in Pt 5, Ch 7, 3.2 Keyless propellers	15%

5.4 Minimum propeller blade tip thickness

5.4.1 The tip thickness, *t*, of the blade at 95 per cent radius is to be not less than that obtained by the following formula:

$$t = \text{mm.} \\ 0,14(T + 57) \sqrt[3]{\frac{430}{\sigma_u}}$$

where

T = blade root thickness required by Pt 8, Ch 2, 5.3 Main engine shafting and propellers 5.3.1, in mm

σ_u = specified minimum tensile strength of material, in N/mm²

5.5 Blade edge thickness

5.5.1 The edges of the blades are to be suitably thickened for the operating conditions but are to be not less than 50 per cent of the required tip thickness, *t*, measured at 1,25 times tip thickness, *t*, from the edge. For controllable pitch propellers, this requirement need only be applied to the leading edges of the blades.

5.6 Cooling water lines

5.6.1 Connections are to be fitted between the cooling water overboard discharge lines and sea inlets for main and/or auxiliary engine cooling water systems so that warm water may be used to assist in maintaining the suction pipes free from ice.

5.6.2 Where the cooling water inlet valves are fitted to a common water box, the connections from the cooling water discharge lines may be led to the water box in a position as near as possible to the inlet valves.

■ **Section 6**
Hull requirements for first-year ice conditions – Ice Classes 1AS FS, 1A FS, 1B FS, 1C FS and 1D

6.1 General

6.1.1 In addition to the requirements of the *Finnish-Swedish Ice Class Rules*, the following Sections are to be complied with for **Ice Class 1AS FS, Ice Class 1A FS, Ice Class 1B FS, Ice Class 1C FS** and **Ice Class 1D**, where applicable. Alternative arrangements to attain similar performance will be considered.

6.2 Framing – General requirements

6.2.1 Where a frame intersects a boundary between two of the hull regions the scantling requirements applicable will be those for the forward region if the forward midship boundary is intersected or for the midship region if the aft midship boundary is intersected.

6.2.2 The effective weld area attaching ice frames to primary members is not to be less than the shear area for the frames.

6.2.3 Asymmetrical frames and frames which are not at right angles to the shell (web less than 90 degrees to the shell) shall be supported against tripping by brackets, intercostals, stringers or similar, at a distance not exceeding 1300 mm. For **Ice Class 1D**, the distance may be increased to 2000 mm. For frames with spans greater than 4 m the extent of anti-tripping supports is to be applied to all regions. For frames with spans less than or equal to 4 m the extent is to be as given in *Table 2.6.1 Extent of anti-tripping supports*. FEA may be carried out to demonstrate equivalent support of alternative arrangements.

Table 2.6.1 Extent of anti-tripping supports

Ice Class	Extent of anti-tripping supports
1AS FS	All regions
1A FS	Forward and midship regions
1B FS	Forward region
1C FS	Forward region
1D	Forward region

6.3 Primary longitudinal members supporting transverse ice framing

6.3.1 The webs of primary longitudinal members supporting transverse ice frames are to be stiffened and connected to the main or intermediate frames so that the distance, *r*, between such stiffening is not to be greater than given according to the following formula:

$$r = \sqrt{\frac{291t^3}{\alpha_o \gamma^2}} \text{ mm}$$

where

t = thickness, in mm, of the primary longitudinal member adjacent to the shell plating

α_o = longitudinal distribution factor as given in *Table 2.6.2 Longitudinal distribution factor α_o*

γ = (a) Forward region

$$= \gamma = 0,653 + 3,217 \sqrt{P_0^\Delta} \times 10^{-5}$$

$$= \gamma = 0,876 + 9,908 \sqrt{P_0^\Delta} \times 10^{-6}$$

= or

$$= \gamma = 1,0, \text{ whichever is the least}$$

= (b) Midship and aft regions

$$= \gamma = 0,653 + 9,908 \sqrt{P_0^\Delta} \times 10^{-6}$$

= or

$$= \gamma = 1,0, \text{ whichever is the least}$$

P_0 and Δ = are as defined in 2.2.

6.3.2 The minimum thickness of the web plating of longitudinal primary members is to comply with the requirements of *Pt 3, Ch 10, 4 Construction details for primary members*.

Table 2.6.2 Longitudinal distribution factor α_0

Ice Class	α_0		
	Forward	Midship	Aft
1AS FS	1,00	0,98	0,89
1A FS	0,87	0,75	0,64
1B FS	0,78	0,64	0,51
1C FS	0,68	0,53	0,37
1D	0,68	—	—

6.4 Stem

6.4.1 The stem is to be made of rolled, cast or forged steel or of shaped steel plates. A sharp edged stem, as shown in *Figure 2.6.1 A sharp edged stem*, improves the manoeuvrability of the ship in ice. Where a sharp angle stem is fitted, the section modulus as given in *Pt 8, Ch 2, 6.4 Stem 6.4.2* and *Pt 8, Ch 2, 6.4 Stem 6.4.3* is to apply to the stem section only, otherwise the section modulus may be applied including side plates.

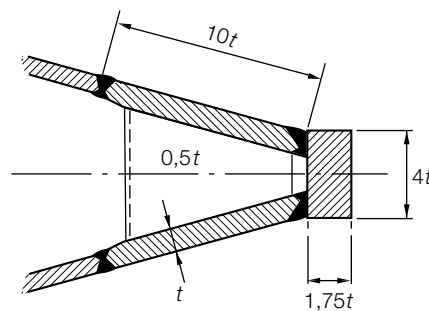

Figure 2.6.1 A sharp edged stem

6.4.2 The section modulus of the stem in the fore and aft direction is not to be less than determined in accordance with the following formula:

$$Z = 1500 (\alpha_0 \gamma^2)^{3/2} \text{ cm}^3$$

where

α_0 = longitudinal distribution factor for the forward region as given in *Table 2.6.2 Longitudinal distribution factor α_0*

γ = is defined in *Pt 8, Ch 2, 6.3 Primary longitudinal members supporting transverse ice framing 6.3.1*.

6.4.3 The dimensions of a welded stem constructed as shown in *Figure 2.6.1 A sharp edged stem* are to be determined in accordance with the following formula:

$$t = 31 \sqrt{\alpha_0 \gamma^2} \text{ mm}$$

where

t = thickness of the side plates, in mm.

6.4.4 In bulbous bow constructions, the extent of plating below the Ice Light Waterline should be such as to cover that part of the bulb forward of the vertical line originating at the intersection of the Ice Light Waterline and the stem contour at the centreline.

A suitably tapered transition piece should be arranged between the reinforced stem plating and keel. However, in no case should the reinforced stem plating extend vertically below the Ice Light Waterline for less than 750 mm. The adjacent strake to the reinforced shaped stem plating of the bulb should be in accordance with the requirements for shell plating.

6.4.5 Where in the ice belt region the radius of the stem or bulb front plating is large, one or more vertical stiffeners are to be fitted in order to meet the section modulus requirement of *Pt 8, Ch 2, 6.4 Stem 6.4.2*. In addition, vertical ring stiffening will be required for the bulb.

6.4.6 The dimensions of the stem may be tapered to the requirements of *Pt 3, Ch 5, 3.3 Stem* at the upper deck. The connections of the shell plating to the stem are to be flush.

6.5 Stern

6.5.1 Where the screwshaft diameter exceeds the Rule diameter, the propeller post is to be correspondingly strengthened, see *Pt 3, Ch 6, 7 Sternframes and appendages*.

6.6 Renewal criteria within ice strengthening area for CSR ships

6.6.1 For double hull oil tankers and bulk carriers that are compliant with the *IACS Common Structural Rules for Bulk Carriers and Oil Tankers (CSR)*, the renewal criteria of the local structure for general corrosion is to be calculated in accordance with the applicable CSR renewal criteria.

6.7 Rudder and steering arrangements

6.7.1 Rudder scantlings, posts, rudder horns, solepieces, rudder stocks, steering engine and pintles are to be dimensioned in accordance with *Pt 3, Ch 6 Aft End Structure* and *Pt 3, Ch 13 Ship Control Systems* as appropriate. The speed used in the calculations is to be the maximum service speed or that given in *Table 2.6.3 Minimum speed*, whichever is the greater. When used in association with the speed given in *Table 2.6.3 Minimum speed*, the rudder profile coefficients are to be taken as 1,1.

Table 2.6.3 Minimum speed

Ice Class	Minimum speed,
	in knots
1AS FS	20
1A FS	18
1B FS	16
1C FS	14
1D	14

6.7.2 For double plate rudders, the minimum thickness of plating and horizontal and vertical webs in the main ice belt zone is to be determined as for shell plating in the aft region. For the horizontal and vertical webs, the corrosion-abrasion increment, need not be added. For **Ice Class 1D**, the minimum thickness of plating and webs, of double plate rudders and the extent of application are to be determined as for those in **Ice Class 1C FS**.

6.7.3 Where an ice class notation is included in the class of a ship, the nozzle construction requirements, as defined in *Table 13.3.1 Nozzle construction requirements* in *Pt 3, Ch 13 Ship Control Systems*, are to be upgraded to include abrasion allowance as follows:

Ice Class	Thickness increment
1AS FS	5 mm
1A FS	4 mm
1B FS	3 mm
1C FS	2 mm
1D	2 mm

However, the thickness of the shroud plating is not to be less than the shell plating for the aft region taking frame spacing s in the formula as 500 mm.

6.7.4 The scantlings of the stock, pintles, gudgeon and solepiece associated with the nozzle are to be increased on the basis given in *Pt 8, Ch 2, 6.7 Rudder and steering arrangements 6.7.1*. However, the diameter of the nozzle stock is to be not less than that calculated in the astern condition taking the astern speed as half the speed given in *Table 2.6.3 Minimum speed* or the actual astern speed, whichever is the greater.

6.7.5 Nozzles with articulated flaps will be subject to special consideration.

6.7.6 For the Ice Classes **1AS FS** and **1A FS**, the rudder stock and the upper edge of the rudder shall be protected against ice pressure by an ice knife or equivalent means. The ice knife is to extend down to the ice light waterline; this requirement may be waived where this would lead to impracticable ice knives, e.g. for ships with large draught variations.

6.7.7 For the Ice Classes **1AS FS** and **1A FS**, due regard is to be paid to the excessive load caused by the rudder being forced out of the midship position when backing into an ice ridge. When vessels are intended to operate with significant time in astern operation, then the hull strength is to be based on the method used in the forward region; however, due consideration may be given to the anticipated power in this mode of operation.

6.7.8 Relief valves for hydraulic pressure are to be effective, see *Pt 5, Ch 19, 3.3 Valve and relief valve arrangements*. The components of the rudder steering gear are to be able to withstand the yield torque of the rudder stock, see *Pt 5, Ch 19, 3.2 Components 3.2.2*.

■ Section 7

Machinery requirements for first-year ice conditions – Ice Classes 1AS FS, 1A FS, 1B FS and 1C FS

7.1 General

7.1.1 In addition to the requirements of the *Finnish-Swedish Ice Class Rules*, the following Sections are to be complied with for **Ice Class 1AS FS**, **Ice Class 1A FS**, **Ice Class 1B FS** and **Ice Class 1C FS**, where applicable. Alternative arrangements to attain similar performance will be specially considered.

7.2 Determination of ice torque

7.2.1 If the propeller is not fully submerged when the ship is in ballast condition, the requirements for **Ice Class 1A FS** is to be used for **Ice Class 1B FS** and **Ice Class 1C FS**.

7.3 Propeller blade sections

7.3.1 Where the blade thickness derived from the *Finnish-Swedish Ice Class Rules* is less than the blade thickness derived by *Pt 5, Ch 7, 3.1 Minimum blade thickness*, the latter is to apply.

7.4 Intermediate blade sections

7.4.1 The thickness of other sections is to conform to a smooth curve connecting the section thicknesses as determined by the *Finnish-Swedish Ice Class Rules*.

7.5 Blade edge thickness

7.5.1 The thickness of blade edges is to be not less than 50 per cent of the derived tip thickness, t , measured at $1,25t$ from edge. For controllable pitch propellers, this applies only to the leading edge.

7.6 Mechanisms for controllable pitch propellers

7.6.1 The strength of mechanisms in the boss of a controllable pitch propeller is to be 1,5 times that of the blade when a load is applied at the radius $0,9D/2$ in the weakest direction of the blade.

7.7 Keyless propellers

7.7.1 When it is proposed to use keyless propellers, the fit of the propeller boss to the screwshaft will be specially considered.

7.8 Screwshafts

7.8.1 Where the screwshaft diameter as derived by the *Finnish-Swedish Ice Class Rules* is less than the diameter derived by *Pt 5, Ch 6, 3.5 Screwshafts and tube shafts 3.5.1*, the latter is to apply.

7.8.2 The diameter, d_s , of the screwshaft determined in accordance with the *Finnish-Swedish Ice Class Rules* is to extend over a length not less than that to the forward edge of the bearing immediately forward of the propeller or $2,5d_s$ whichever is the greater.

7.8.3 The shaft may be tapered at the forward end in accordance with *Pt 5, Ch 6, 3.5 Screwshafts and tube shafts 3.5.3* and *Pt 5, Ch 6, 3.5 Screwshafts and tube shafts 3.5.4*, except for **Ice Class 1AS FS** ice strengthening, where these diameters are to be increased by 10 per cent.

7.8.4 For screwshafts in ships intended for the notation **Ice Class 1AS FS** or **Ice Class 1A FS** and where the connection between the propeller and the screwshaft is by means of a key, Charpy impact tests are to be made in accordance with the requirements of *Ch 5, 3.4 Mechanical tests 3.4.12* of the Rules for Materials.

7.9 Intermediate and thrust shafts

7.9.1 The diameters of intermediate shafts and thrust shafts in external bearings are to comply with *Pt 5, Ch 6, 3.1 Intermediate shafts* and *Pt 5, Ch 6, 3.4 Thrust shafts* respectively, except for **Ice Class 1AS FS** ice strengthening where these diameters are to be increased by 10 per cent.

Section 8
Hull requirements for first-year ice conditions – Ice classes 1AS FS(+), 1A FS(+), 1B FS(+) and 1C FS(+)
8.1 General

8.1.1 The requirements for **Ice Class 1AS FS**, **Ice Class 1A FS**, **Ice Class 1B FS** and **Ice Class 1C FS**, as applicable, are to be applied using the installed engine power as given by *Pt 8, Ch 2, 9 Machinery requirements for first-year ice conditions - Ice classes 1AS FS(+), 1A FS(+), 1B FS(+) and 1C FS(+)*.

Section 9
Machinery requirements for first-year ice conditions - Ice classes 1AS FS(+), 1A FS(+), 1B FS(+) and 1C FS(+)
9.1 Powering of ice strengthened ships

9.1.1 For ships that require additional strengthening in ice, the total shaft power installed is to be calculated using the following Sections, but is not to be less than required by the *Finnish-Swedish Ice Class Rules* in force at the time of contract.

9.1.2 Ice strengthened ships which are to be considered to have an icebreaking capability are to be able to develop sufficient thrust to permit continuous mode icebreaking at a speed of at least five knots in ice having a thickness equal to the nominal value for the desired Ice Class and a snow cover of at least 0,3 m.

9.1.3 The shaft power necessary to provide an icebreaking capability can be determined by the equation:

$$P_1 = 0,736C_1C_2C_3C_4[240Bh(1 + h + 0,035v^2) + 70S_c\sqrt{L}] \text{ kW}$$

where

B = moulded breadth of ship, in metres, see Pt 3, Ch 1, 6.1 Principal particulars 6.1.3

L = Rule length, in metres, see Pt 3, Ch 1, 6.1 Principal particulars 6.1.1

Δ = displacement, in tonnes, see Pt 3, Ch 9,7.2.1

$$C_1 = \frac{1,2B}{\sqrt[3]{\Delta}}$$

but is not to be taken as less than 1,0

C_2 = 0,9 if the ship is fitted with a controllable pitch propeller, otherwise 1,0

C_3 = 0,9 if the rake of the stem is 45° or less, otherwise 1,0. The product $C_2 C_3$ is not to be taken as less than 0,85

C_4 = 1,1 if the ship is fitted with a bulbous bow, otherwise 1,0

h = ice thickness

= 1,0 for **Ice Class 1AS FS(+)**

= 0,8 for **Ice Class 1A FS(+)**

= 0,6 for **Ice Class 1B FS(+)**

= 0,4 for **Ice Class 1C FS(+)**

S_c = depth of snow cover

v = ship speed, in knots, when breaking ice of thickness h .

9.2 Materials for shafting

9.2.1 For screwshafts in ships intended for the notation **Ice Class 1AS FS(+)** or **Ice Class 1A FS(+)** and where the connection between the propeller and the screwshaft is by means of a key, Charpy impact tests are to be made in accordance with the requirements of Ch 5, 3.4 Mechanical tests 3.4.12 of the Rules for Materials.

Section 10

Hull strengthening requirements for navigation in multi-year ice conditions – Ice Classes PC1, PC2, PC3, PC4, PC5, PC6, PC7 and Icebreaker

10.1 Hull Areas

10.1.1 The hull of all polar class ships is divided into areas reflecting the magnitude of the loads that are expected to act upon them, see Figure 2.10.1 Extent of hull areas. In the longitudinal direction, there are four regions:

- bow, (B);
- bow intermediate, (B_i);
- midbody, (M), and
- stern (S).

The bow intermediate, midbody and stern regions are further divided in the vertical direction into three regions:

- bottom, (b)
- lower, (l) and
- icebelt (i).

10.1.2 The upper ice waterline, UIWL, and lower ice waterline, LIWL, are as defined in *Pt 8, Ch 2, 2.2 Definitions*.

10.1.3 In addition to *Figure 2.10.1 Extent of hull areas*, at no time is the boundary between the bow and bow intermediate regions to be forward of the intersection point of the line of the stem and the ship baseline.

10.1.4 In addition to *Figure 2.10.1 Extent of hull areas*, the aft boundary of the bow region need not be more than 0,45L aft of the forward perpendicular, FP.

10.1.5 The boundary between the bottom and lower regions is to be taken at the point where the tangent to the shell is inclined 7° from horizontal.

10.1.6 If a ship is intended to operate astern in ice regions, the aft section of the ship is to be designed based on the bow and bow intermediate hull area requirements.

10.2 Design ice loads – General

10.2.1 For ships of all Polar Classes, a glancing impact on the bow is the design scenario for determining the scantlings required to resist ice loads.

10.2.2 The design ice load is characterised by an average pressure, P_a , uniformly distributed over a rectangular load patch of height, b , and width, w .

10.2.3 Within the bow area of all polar classes, and within the bow intermediate icebelt area of polar classes **PC6** and **PC7**, the ice load parameters are functions of the actual bow shape. To determine the ice load parameters, P_a , b and w , it is required to calculate the following ice load characteristics for sub-regions of the bow area; shape coefficient, f_{ai} , total glancing impact force, F_i , line load, Q_i , and pressure, P_i .

10.2.4 In other ice-strengthened areas, the ice load parameters, P_a , b_{NB} and w_{NB} , are determined independently of the hull shape and based on a fixed load patch aspect ratio, $AR = 3.6$.

10.2.5 Design ice forces calculated according to *Pt 8, Ch 2, 10.3 Glancing impact load characteristics* are only valid for vessels with icebreaking forms. Design ice forces for any other bow forms are to be specially considered.

10.2.6 Ship structures that are not directly subjected to ice loads may still experience inertial loads of stowed cargo and equipment resulting from ship/ice interaction. These inertial loads are to be considered in the design of these structures.

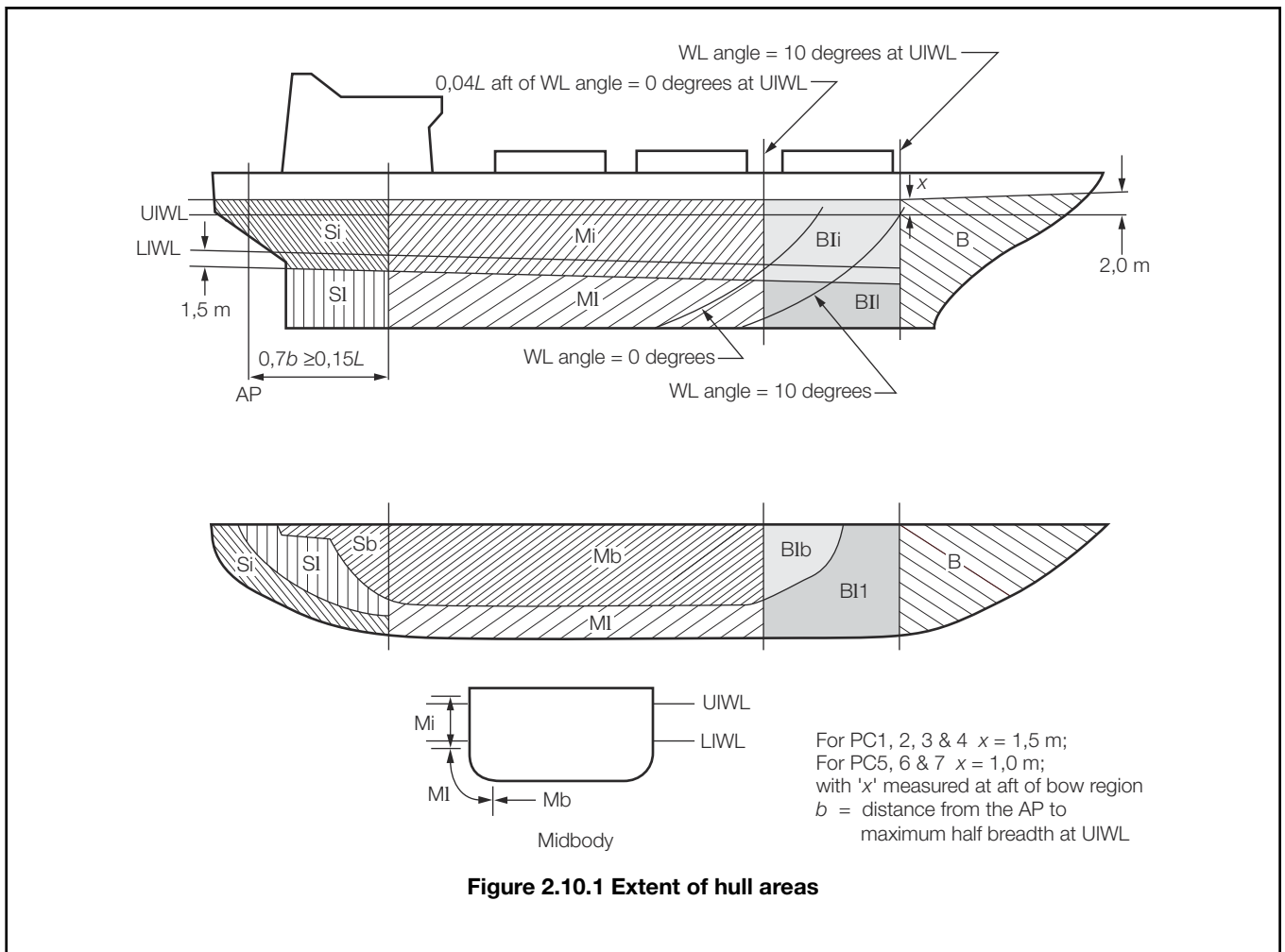

10.3 Glancing impact load characteristics

10.3.1 The parameters defining the glancing impact load characteristics are reflected in the class factors listed in *Table 2.10.1 Class factors*.

Table 2.10.1 Class factors

Polar Class	Crushing failure class factor	Flexural failure class factor	Load patch dimensions class factor	Displacement class factor	Longitudinal strength class factor
	C_C	C_F	C_D	C_{DI}	C_L
PC1	17,69	68,60	2,01	250	7,46
PC2	9,89	46,80	1,75	210	5,46
PC3	6,06	21,17	1,53	180	4,17
PC4	4,50	13,48	1,42	130	3,15
PC5	3,10	9,00	1,31	70	2,50

PC6	2,40	5,49	1,17	40	2,37
PC7	1,80	4,06	1,11	22	1,81

10.4 Bow area

10.4.1 In the bow area, the force, F , line load, Q , pressure, P , and load patch aspect ratio, AR , associated with the glancing impact load scenario are functions of the hull angles measured at the upper ice waterline, UIWL. The influence of the hull angles is captured through calculation of a bow shape coefficient, fa . The hull angles are defined in *Figure 2.10.2 Definition of hull angles*.

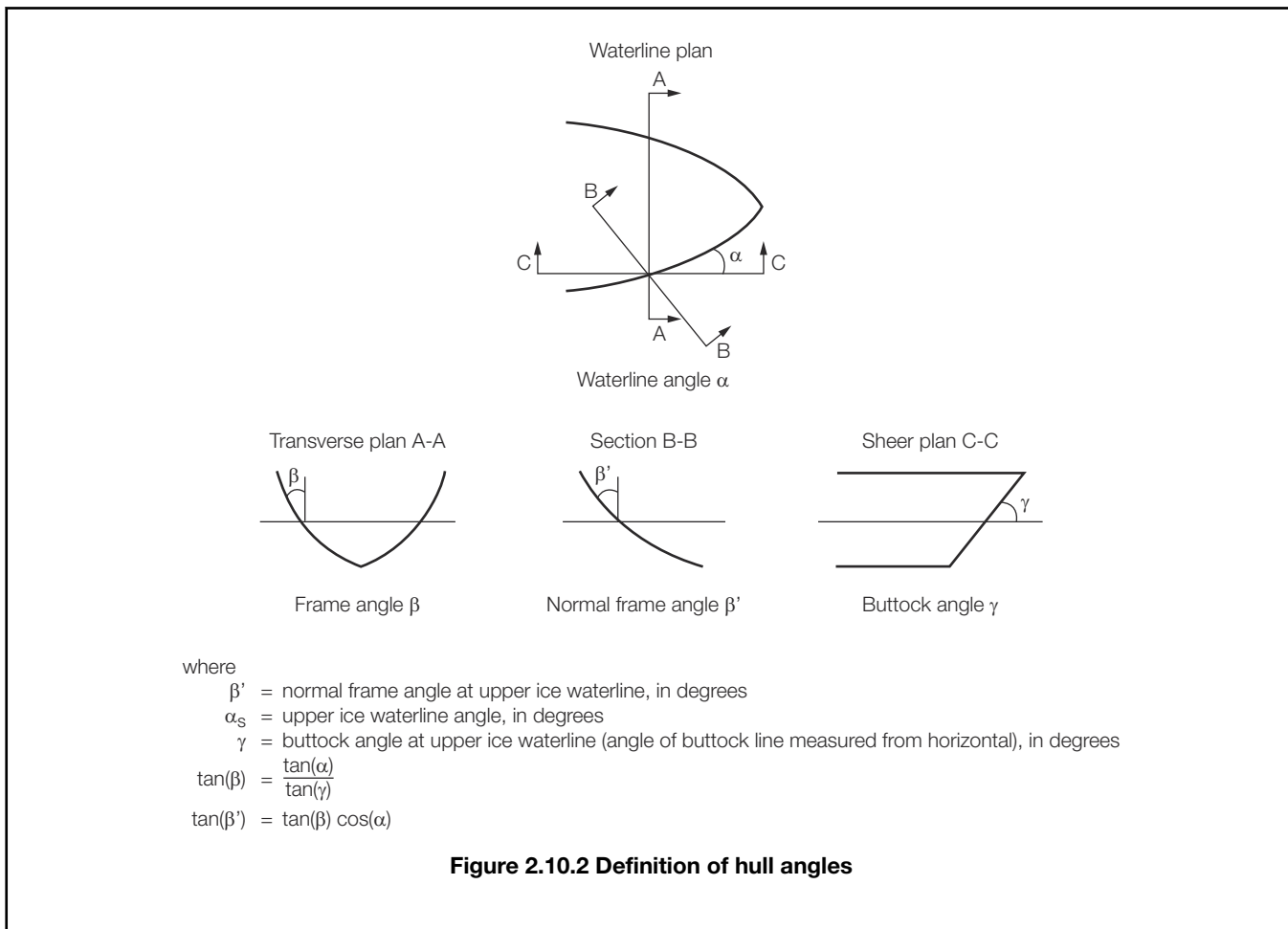

10.4.2 The waterline length of the bow region is generally to be divided into four sub-regions of equal length. The force, F , line load, Q , pressure, P , and load patch aspect ratio, AR , are to be calculated with respect to the mid-length position of each sub-region (each maximum of F , Q and P is to be used in the calculation of the ice load parameters $P_{a'}$, b and w).

10.4.3 The bow area load characteristics are determined as follows:

(a) The shape coefficient, fa_i , is to be taken as

$$fa_i = fa_{i,1}$$

$$fa_{i,2}$$

$fa_{i,3}$ whichever is the lesser

where

$$fa_{i,1} = \left(0,097 - 0,68 \left(\frac{x}{L} - 0,15 \right)^2 \right) \frac{\alpha_i}{\sqrt{\beta'_i}}$$

$$fa_{i,2} = \frac{1,2C_F}{\sin(\beta'_i)C_c \Delta^{0,64}}$$

$$fa_{i,3} = 0,60$$

i = sub-region considered

L = ship length, as defined in *Pt 3, Ch 1, 6.1 Principal particulars 6.1.1*, but measured on the upper ice waterline (UIWL), in metres

x = distance from the forward perpendicular (FP) to station under consideration, in metres

α = waterline angle, in degrees, see *Figure 2.10.2 Definition of hull angles*

β' = normal frame angle, in degrees, see *Figure 2.10.2 Definition of hull angles*

Δ = ship displacement, in kilo tonnes, not to be taken less than 5

C_C = crushing failure class factor from *Table 2.10.1 Class factors*

C_F = flexural failure class factor from *Table 2.10.1 Class factors*

(b) Force, F_i :

$$F_i = fa_i C_c \Delta^{0,64} \text{ MN}$$

where

i = sub-region considered

fa_i = shape coefficient of sub-region, i

C_C = crushing failure class factor from *Table 2.10.1 Class factors*

Δ = ship displacement, in kilo tonnes, not to be taken less than 5

(c) Load patch aspect ratio, AR_i :

$$AR_i = 7,46 \sin(\beta'_i)$$

$$AR_i \geq 1,3$$

where

i = sub-region considered

β'_i = normal frame angle of sub-region i , in degrees

(d) Line load, Q_i :

$$Q_i = \frac{F_i^{0,61} C_D}{AR_i^{0,35}} \text{ MN/m}$$

where

i = sub-region considered

F_i = force of sub-region i , in MN

C_D = load patch dimensions class factor from *Table 2.10.1 Class factors*

AR_i = load patch aspect ratio of sub-region i

(e) Pressure, P_i :

$$P_i = F_i^{0,22} C_D^2 AR_i^{0,3} \text{ MPa}$$

where

I = sub-region considered

F_i = force of sub-region i , in MN

C_D = load patch dimensions class factor from *Table 2.10.1 Class factors*

AR_i = load patch aspect ratio of sub-region i .

10.5 Hull areas other than the bow

10.5.1 In the hull areas other than the bow, the force, F_{NB} , and line load, Q_{NB} , used in the determination of the load patch dimensions, b_{NB} , w_{NB} , and design pressure, P_a , are determined as follows:

(a) Force, F_{NB} :

$$F_{NB} = 0,36 C_C \Delta_F \text{ MN}$$

where

C_C = crushing force class factor from *Table 2.10.1 Class factors*

Δ_F = ship displacement factor

$$= \Delta^{0,64} \text{ if } \Delta \leq C_{DI}$$

$$= C_{DI}^{0,64} + 0,10 (\Delta - C_{DI}) \text{ if } \Delta > C_{DI}$$

Δ = ship displacement, in kilo tonnes, not to be taken less than 10

C_{DI} = displacement class factor from *Table 2.10.1 Class factors*

(b) Line Load, Q_{NB} :

$$Q_{NB} = 0,639 F_{NB}^{0,61} C_D \text{ MN/m}$$

where

F_{NB} = force from *Pt 8, Ch 2, 10.5 Hull areas other than the bow 10.5.1*, in MN

C_D = load patch dimensions class factor from *Table 2.10.1 Class factors*.

10.6 Design load patch

10.6.1 In the bow area, and the bow Intermediate Icebelt area for ships with class notation **PC6** and **PC7**, the design load patch has dimensions of width, w_B , and height, b_B , defined as follows:

$$w_B = \frac{F_B}{Q_B} \text{ m}$$

$$b_B = \frac{Q_B}{P_B} \text{ m}$$

where

F_B = maximum F_i in the bow area, in MN

Q_B = maximum Q_i in the bow area, in MN/m

P_B = maximum P_i in the bow area, in MPa.

10.6.2 In hull areas other than those covered by *Pt 8, Ch 2, 10.6 Design load patch 10.6.1*, the design load patch has dimensions of width, w_{NB} , and height, b_{NB} , defined as follows:

$$w_{NB} = \frac{F_{NB}}{Q_{NB}} \text{ m}$$

$$b_{NB} = \frac{W_{NB}}{3,6} \text{ m}$$

where

F_{NB} = force determined using *Pt 8, Ch 2, 10.5 Hull areas other than the bow 10.5.1*, in MN

Q_{NB} = line load determined using *Pt 8, Ch 2, 10.5 Hull areas other than the bow 10.5.1*, in MN/m.

10.7 Pressure within the design load patch

10.7.1 The average pressure, P_a , within a design load patch is determined as follows:

$$P_a = \frac{F}{bw} \text{ MPa}$$

where

F = F_B or F_{NB} as appropriate for the hull area under consideration, in MN

b = b_B or b_{NB} as appropriate for the hull area under consideration, in metres

w = w_B or w_{NB} as appropriate for the hull area under consideration, in metres.

10.7.2 Areas of higher, concentrated pressure exist within the load patch. In general, smaller areas have higher local pressures. Accordingly, the peak pressure factors listed in *Table 2.10.2 Peak pressure factors* are used to account for the pressure concentration on localised structural members.

Table 2.10.2 Peak pressure factors

Structural member		Peak pressure factor, K_i	
Plating	Transversely framed	$K_p = (1,8 - s) \geq 1,2$	
	Longitudinally framed	$K_p = (2,2 - 1,2s) \geq 1,5$	
Frames in transverse framing systems	With load distributing stringers	$K_t = (1,6 - s) \geq 1,0$	
	With no load distributing stringers	$K_t = (1,8 - s) \geq 1,2$	
Load carrying stringers		$K_s = 1$	if $S_w \geq 0,5w$
Side and bottom longitudinals Web frames		$K_s = 2 - \frac{2S_w}{w}$	if $S_w < 0,5w$
Symbols			
s = frame or longitudinal spacing, in metres			

S_w = web frame spacing, in metres
w = ice load patch width, in metres

10.8 Hull area factors

10.8.1 Associated with each hull area is an area factor that reflects the relative magnitude of the load expected in that area. The area factor, AF , for each hull area is listed in *Table 2.10.3 Hull area factors (AF)*.

10.8.2 In the event that a structural member spans across the boundary of a hull area, the largest hull area factor is to be used in the scantling determination of the member.

10.8.3 Due to their increased manoeuvrability, ships having propulsion arrangements with azimuthing thruster(s) or podded propellers shall have specially considered stern icebelt, S_i , and stern lower, S_l , hull area factors.

Table 2.10.3 Hull area factors (AF)

Hull area		Area	Polar Class						
			PC1	PC2	PC3	PC4	PC5	PC6	PC7
Bow (B)	All	B	1,00	1,00	1,00	1,00	1,00	1,00	1,00
	Icebelt	B_{li}	0,90	0,85	0,85	0,80	0,80	see Note 1	see Note 1
Bow intermediate (B)	Lower	B_{li}	0,70	0,65	0,65	0,60	0,55	0,55	0,50
	Bottom	B_{lb}	0,55	0,50	0,45	0,40	0,35	0,30	0,25
Midbody (M)	Icebelt	M_i	0,70	0,65	0,55	0,55	0,50	0,45	0,45
	Lower	M_l	0,50	0,45	0,40	0,35	0,30	0,25	0,25
	Bottom	M_b	0,30	0,30	0,25	see Note 2	see Note 2	see Note 2	see Note 2
Stern (S)	Icebelt	S_i	0,75	0,70	0,65	0,60	0,50	0,40	0,35
	Lower	S_l	0,45	0,40	0,35	0,30	0,25	0,25	0,25
	Bottom	S_b	0,35	0,30	0,30	0,25	0,15	see Note 2	see Note 2

Note 1. See Pt 8, Ch 2, 10.2 Design ice loads – General 10.2.3.

Note 2. Indicates that strengthening for ice loads is not necessary.

10.8.4 Area factors to be applied to ships assigned the notation **Icebreaker** are given in *Table 2.10.4 Hull area factors (AF) for icebreaker*.

Table 2.10.4 Hull area factors (AF) for icebreaker

	B	B _{li}	B _{ll}	B _{lb}	M _i	M _l	M _b	S _i	S _l	S _b
PC1	1	0,90	0,70	0,55	0,70	0,50	0,30	0,94	0,56	0,35
PC2	1	0,85	0,65	0,50	0,65	0,45	0,30	0,88	0,50	0,30
PC3	1	0,85	0,65	0,45	0,55	0,40	0,25	0,81	0,44	0,30
PC4	1	0,85	0,65	0,45	0,55	0,40	0,25	0,81	0,44	0,30
PC5	1	0,85	0,65	0,45	0,55	0,40	0,25	0,81	0,44	0,30

PC6	1	1	0,65	0,45	0,55	0,40	0,25	0,81	0,44	0,30
PC7	1	1	0,65	0,45	0,55	0,40	0,25	0,81	0,44	0,30

10.9 Shell plate requirements

10.9.1 The required minimum shell plate thickness, t , is given by:

$$t = t_{\text{net}} + t_s \text{ mm}$$

where

t_{net} = plate thickness required to resist ice loads according to Pt 8, Ch 2, 10.9 Shell plate requirements 10.9.2, in mm

t_s = corrosion and abrasion allowance according to Pt 8, Ch 2, 10.16 Corrosion/abrasion additions and steel renewal, in mm.

10.9.2 The thickness of shell plating required to resist the design ice load, t_{net} , depends on the orientation of the framing. The plating, including all bottom plating, i.e. plating in hull areas B_{lb} , M_{b} and S_{b} , the net thickness is given by Table 2.10.5 Shell plate thickness.

Table 2.10.5 Shell plate thickness

Transversely framed plating	Obliquely framed plating	Longitudinally framed plating	
$\Omega \geq 70^\circ$	$70^\circ > \Omega > 20^\circ$	$\Omega \leq 20^\circ$	
		$b \geq s$	$b < s$
$t_{\text{net}} = \frac{500s \sqrt{\frac{AF K_p P_a}{\sigma_y}}}{1 + \frac{s}{2b}} \text{ mm}$	linear interpolation	$t_{\text{net}} = \frac{500s \sqrt{\frac{AF K_p P_a}{\sigma_y}}}{1 + \frac{s}{2l}} \text{ mm}$	$t_{\text{net}} = \frac{500s \sqrt{\frac{AF K_p P_a}{\sigma_y}} \sqrt{\frac{2b}{s} - \left(\frac{b}{s}\right)^2}}{1 + \frac{s}{2l}} \text{ mm}$
Symbols			
<p>Ω = smallest angle between the chord of the waterline and the line of the first level framing as illustrated in Figure 2.10.3 Shell framing angle Ω, in degrees</p> <p>s = transverse frame spacing in transversely-framed ships or longitudinal frame spacing in longitudinally-framed ships, in metres</p> <p>AF = hull area factor from Table 2.10.3 Hull area factors (AF)</p> <p>K_p = peak pressure factor from Table 2.10.2 Peak pressure factors</p> <p>P_a = average patch pressure according to Pt 8, Ch 2, 10.7 Pressure within the design load patch 10.7.1, in MPa</p> <p>σ_y = minimum upper yield stress of the material, in N/mm²</p>			

b = height of design load patch, in m, where $b \leq l - \frac{s}{4}$ in the case of transversely framed plating

l = distance between frame supports, i.e. equal to the frame span as given in Pt 8, Ch 2, 10.10 Framing – General 10.10.5, but not reduced for any fitted end brackets, in metres. When a load-distributing stringer is fitted, the length, l , need not be taken larger than the distance from the stringer to the most distant frame support

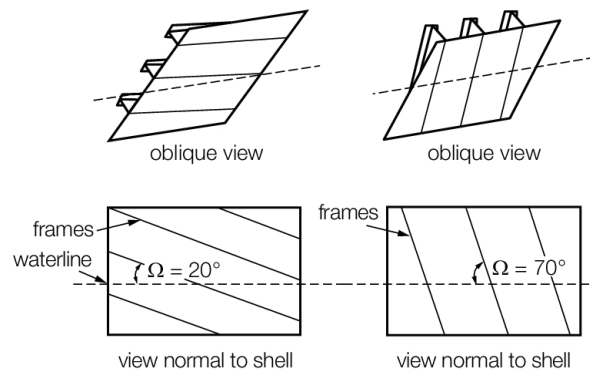

Figure 2.10.3 Shell framing angle Ω

10.10 Framing – General

10.10.1 Framing members of Polar class ships are to be designed to withstand the ice loads defined in Pt 8, Ch 2, 10.2 Design ice loads – General

10.10.2 The term ‘framing member’ refers to transverse and longitudinal local frames, load-carrying stringers and web frames in the areas of the hull exposed to ice pressure, see Figure 2.10.1 Extent of hull areas. Where load-distributing stringers have been fitted, the arrangement and scantlings of these are to be suitably designed.

10.10.3 The strength of a framing member is dependent upon the fixity that is provided at its supports. Fixity can be assumed where framing members are either continuous through the support or attached to a supporting section with a connection bracket. In other cases, simple support is to be assumed unless the connection can be demonstrated to provide significant rotational restraint. Fixity is to be ensured at the support of any framing which terminates within an ice-strengthened area.

10.10.4 The details of framing member intersection with other framing members, including plated structures, as well as the details for securing the ends of framing members at supporting sections, are to be in accordance with Pt 3, Ch 10 Welding and Structural Details.

10.10.5 The design span of a framing member is to be determined on the basis of its moulded length. If brackets are fitted, the design span may be reduced in accordance with Pt 3, Ch 3 Structural Design.

10.10.6 When calculating the section modulus and shear area of a framing member, the net thicknesses of the web, flange (if fitted) and attached shell plating are to be used. The shear area of a framing member may include that material contained over the full depth of the member, i.e. web area including portion of flange, if fitted, but excluding attached shell plating.

10.10.7 The actual net effective shear area, A_w , of a framing member is given by:

$$A_w = \frac{h t_{wn} \sin \varphi_w}{100} \text{ cm}^2$$

where

h = height of stiffener, in mm, see Figure 2.10.4 Stiffner geometry

t_{wn} = net web thickness, in mm

$$= t_w - t_c$$

t_w = as built web thickness, in mm, see *Figure 2.10.4 Stiffner geometry*

t_c = corrosion deduction, in mm, to be subtracted from the web and flange thickness (as specified by t_s in *Pt 8, Ch 2, 10.16 Corrosion/abrasion additions and steel renewal 10.16.3*)

ϕ_w = smallest angle between shell plate and stiffener web, measured at the midspan of the stiffener, see *Figure 2.10.4 Stiffner geometry*. The angle ϕ_w may be taken as 90° provided the smallest angle is not less than 75° .

10.10.8 When the cross-sectional area of the attached plate flange exceeds the cross-sectional area of the local frame, the actual net effective plastic section modulus, Z_p , is given by:

$$Z_p = \frac{A_{pn}t_{pn}}{20} + \frac{h_w^2 t_{wn} \sin \phi_w}{2000} + \frac{A_{fn}(h_{fc} \sin \phi_w - b_w \cos \phi_w)}{10} \text{ cm}^3$$

where

A_{pn} = net cross-sectional area of the local frame, in cm^2

t_{pn} = fitted net shell plate thickness, in mm, (shall comply with t_{net} as required by *Pt 8, Ch 2, 10.9 Shell plate requirements 10.9.2*)

h_w = height of local frame web, in mm, see *Figure 2.10.4 Stiffner geometry*

A_{fn} = net cross-sectional area of local frame flange, in cm^2

h_{fc} = height of local frame measured to centre of the flange area, in mm, see *Figure 2.10.4 Stiffner geometry*

b_w = distance from mid thickness plane of local frame web to the centre of the flange area, in mm, see *Figure 2.10.4 Stiffner geometry*

h , t_w , t_c and ϕ_w are as given in *Pt 8, Ch 2, 10.10 Framing – General 10.10.7*

s as given in *Pt 8, Ch 2, 10.9 Shell plate requirements 10.9.2*

10.10.9 When the cross-sectional area of the local frame exceeds the cross-sectional area of the attached plate flange, the plastic neutral axis is located a distance z_{na} above the attached shell plate, given by:

$$z_{na} = \frac{100A_{fn} + h_w t_{wn} - 1000t_{pn}s}{2t_{wn}} \text{ mm}$$

and the net effective plastic section modulus, Z_p , is given by:

$$Z_p = t_{pn}s \left(z_{na} + \frac{t_{pn}}{2} \right) \sin \phi_w + \left(\frac{((h_w - z_{na})^2 + z_{na}^2) t_{wn} \sin \phi_w}{2000} + \frac{A_{fn}((h_{fc} - z_{na}) \sin \phi_w - b_w \cos \phi_w)}{10} \right) \text{ cm}^3$$

10.10.10 In the case of oblique framing arrangement ($70^\circ > \Omega > 20^\circ$, where Ω is defined as given in *Pt 8, Ch 2, 10.9 Shell plate requirements 10.9.2*), linear interpolation is to be used.

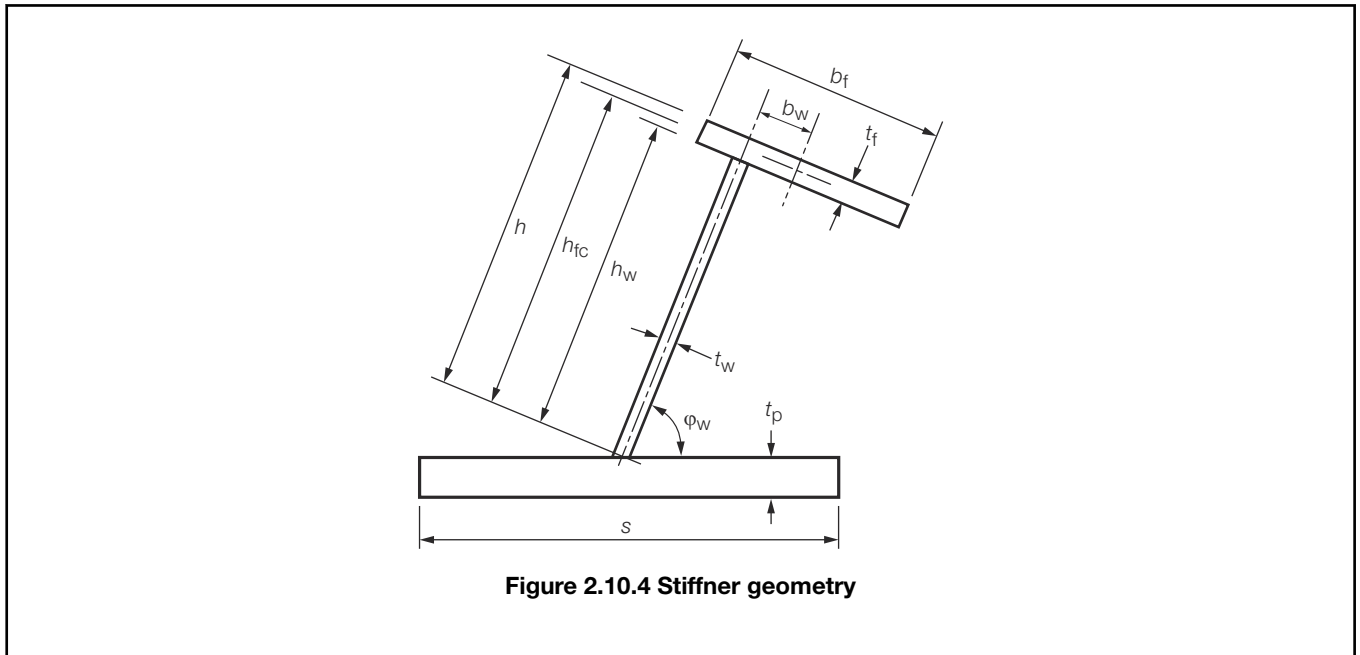

Figure 2.10.4 Stiffener geometry

10.11 Framing – Transversely-framed side structures and bottom structures

10.11.1 The local frames in transversely-framed side structures and in bottom structures (i.e. hull areas B_{lb} , M_b and S_b) are to be dimensioned such that the combined effects of shear and bending do not exceed the plastic strength of the member. The plastic strength is defined by the magnitude of midspan load that causes the development of a plastic collapse mechanism.

10.11.2 The actual net effective shear area of the frame, A_w , as defined in Pt 8, Ch 2, 10.10 Framing – General 10.10.7, is to comply with the following condition:

$$A_w \geq A_t$$

where

$$A_t = 5000 l_L s \frac{AFK_t P_a}{0,577 \sigma_y} \text{ cm}^2$$

l_L = length of loaded portion of span, in metres

need not exceed the lesser of a and b

a = frame span as defined in Pt 8, Ch 2, 10.10 Framing – General 10.10.5, in metres

b = height of design ice load patch according to 10.6, in metres

s = transverse frame spacing, in metres

AF = hull area factor from Table 2.10.3 Hull area factors (AF)

K_t = peak pressure factor from Table 2.10.2 Peak pressure factors

P_a = average pressure within load patch according to 2.10.7, in MPa

σ_y = minimum upper yield stress of the material, in N/mm²

10.11.3 The actual net effective plastic section modulus of the plate/stiffener combination, Z_p , as defined in Pt 8, Ch 2, 10.10 Framing – General 10.10.8 or Pt 8, Ch 2, 10.10 Framing – General 10.10.9, is to comply with the following conditions and is to be the greatest of the two load conditions:

- (a) ice load acting at the midspan of the transverse frame, and
- (b) the ice load acting near a support.

$$Z_p \geq Z_{pt}$$

where

$$Z_{pt} = \frac{100^3 l_L Y_s A F K_t P_a a A_1}{4 \sigma_y} \text{ cm}^3$$

$$Y = 1 - \frac{l_L}{2a}$$

A_1 = reflects the two conditions and is to be taken as the greater of A_{1A} or A_{1B}

$$A_{1A} = \frac{1}{1 + \frac{j}{2} + k_w \frac{j}{2} (\sqrt{1 - a_1^2} - 1)}$$

$$A_{1B} = \frac{1 - \frac{1}{2a_1 Y}}{0,275 + 1,44k_z^{0,7}}$$

j = 1 for framing with one simple support outside the ice strengthened areas

= 2 for framing without any simple supports

$$a_1 = \frac{A_t}{A_w}$$

A_t = rule minimum shear area of transverse frame as given in Pt 8, Ch 2, 10.11 Framing – Transversely-framed side structures and bottom structures 10.11.2, in cm²

A_w = effective net shear area of transverse frame (calculated according to Pt 8, Ch 2, 10.10 Framing – General 10.10.7), in cm²

$$k_w = \frac{1}{1 + \frac{2A_{fn}}{A_w}}$$

A_{fn} = as given in Pt 8, Ch 2, 10.10 Framing – General 10.10.8

$$k_z = \frac{z_p}{Z_p} \text{ in general}$$

= 0 when the frame is arranged with end bracket

z_p = sum of individual plastic section moduli of flange and shell plate as fitted, in cm³

$$= \frac{\frac{b_f t_{fn}^2}{4} f_n + \frac{b_e t_{pn}^2}{4}}{1000}$$

b_f = flange breadth, in mm, see Figure 2.10.4 Stiffner geometry

t_{fn} = net flange thickness, in mm

$$= t_f - t_c$$

t_c = as given in Pt 8, Ch 2, 10.10 Framing – General 10.10.7

t_f = as-built flange thickness, in mm, see Figure 2.10.4 Stiffner geometry

t_{pn} = the fitted net shell plate thickness, in mm, but is not to be less than t_n as given in Pt 8, Ch 2, 10.9 Shell plate requirements

b_e = effective width of shell plate flange, in mm

$$= 500s$$

Z_p = net effective plastic section modulus of transverse frame (calculated according to Pt 8, Ch 2, 10.10 Framing – General 10.10.8 or Pt 8, Ch 2, 10.10 Framing – General 10.10.9), in cm³

$AF, K_t, P_a, l_L, b, s, a$ and σ_y are as given in Pt 8, Ch 2, 10.11 Framing – Transversely-framed side structures and bottom structures 10.11.2.

10.11.4 The scantlings of the frame are to meet the structural stability requirements of Pt 8, Ch 2, 10.14 Framing – Structural stability.

10.12 Framing – Side longitudinals (longitudinally framed ships)

10.12.1 Side longitudinals are to be dimensioned such that the combined effects of shear and bending do not exceed the plastic strength of the member. The plastic strength is defined by the magnitude of midspan load that causes the development of a plastic collapse mechanism.

10.12.2 The actual net effective shear area of the frame, A_w , as defined in Pt 8, Ch 2, 10.10 Framing – General 10.10.7, is to comply with the following condition:

$$A_w \geq A_L$$

where

$$A_L = \frac{5000AFK_s P_a b_1 a}{0,577 \sigma_y} \text{ cm}^2$$

AF = hull area factor from Table 2.10.3 Hull area factors (AF)

K_s = peak pressure factor from Table 2.10.2 Peak pressure factors

P_a = average pressure within load patch according to Pt 8, Ch 2, 10.7 Pressure within the design load patch 10.7.1, in MPa

$$b_1 = k_o b_2 \text{ m}$$

$$k_o = 1 - \frac{0,3}{b'}$$

$$b' = \frac{b}{s}$$

b = height of design ice load patch from 10.6, in metres

s = spacing of longitudinal frames, in metres

$$b_2 = b(1 - 0,25b') \text{ m}$$

if $b' < 2$

$$= s \text{ m}$$

if $b' \geq 2$

a = longitudinal design span as given in Pt 8, Ch 2, 10.10 Framing – General 10.10.5, in metres

σ_y = minimum upper yield stress of the material, in N/mm²

10.12.3 The actual net effective plastic section modulus of the plate/stiffener combination, Z_p , as defined in Pt 8, Ch 2, 10.10 Framing – General 10.10.8 or Pt 8, Ch 2, 10.10 Framing – General 10.10.9, is to comply with the following condition:

$$Z_p \geq Z_{pL}$$

where

$$Z_{pL} = \frac{100^3 AF K_s P_a b_1 a^2 A_4}{8 \sigma_y} \text{ cm}^3$$

$$A_4 = \frac{1}{2 + k \sqrt{1 - a^2/4 - 1}}$$

where

$$a_4 = \frac{A_L}{A_w}$$

A_L = rule minimum shear area for longitudinal as given in Pt 8, Ch 2, 10.12 Framing – Side longitudinals (longitudinally framed ships) 10.12.2, in cm²

A_w = net effective shear area of longitudinal (calculated according to Pt 8, Ch 2, 10.10 Framing – General 10.10.7), in cm²

$$k_{wl} = \frac{1}{1 + \frac{2A_{fn}}{A_w}}$$

A_{fn} = as given in Pt 8, Ch 2, 10.10 Framing – General 10.10.8

AF , K_s , P_a , b_1 , a and σ_y are as given in Pt 8, Ch 2, 10.12 Framing – Side longitudinals (longitudinally framed ships) 10.12.2.

10.12.4 The scantlings of the longitudinals are to meet the structural stability requirements of Pt 8, Ch 2, 10.14 Framing – Structural stability.

10.13 Framing – Web frame and load carrying stringers

10.13.1 Web frames and load-carrying stringers are to be designed to withstand the ice load patch as defined in Pt 8, Ch 2, 10.7 Pressure within the design load patch. The load patch is to be applied at locations where the capacity of these members under the combined effects of bending and shear is minimised.

10.13.2 Web frames and load-carrying stringers are to be dimensioned to take into account the combined effects of shear and bending. Where these members form part of a structural grillage system, appropriate methods of analysis are to be used. Where the structural configuration is such that members do not form part of a grillage system, the appropriate peak pressure factor, K_i , from Table 2.10.2 Peak pressure factors is to be used. Special attention is to be paid to the shear capacity in way of lightening holes and cut-outs in way of intersecting members.

10.13.3 The scantlings of web frames and load-carrying stringers are to meet the structural stability requirements of Pt 8, Ch 2, 10.14 Framing – Structural stability.

10.14 Framing – Structural stability

10.14.1 To prevent local buckling in the web, the ratio of web height, h_w , to net web thickness, t_{wn} , of any framing member is not to exceed:

For flat bar sections: $\frac{h_w}{t_{wn}} \leq \frac{282}{\sqrt{\sigma_y}}$

For bulb, tee and angle sections: $\frac{h_w}{t_{wn}} \leq \frac{805}{\sqrt{\sigma_y}}$

where

h_w = web height

t_{wn} = net web thickness

σ_y = minimum upper yield stress of the shell plate in way of the framing member, in N/mm²

10.14.2 Framing members for which it is not practicable to meet the requirements of 10.14.1 (e.g. load carrying stringers or deep web frames) are required to have their webs effectively stiffened. The scantlings of the web stiffeners are to ensure the structural stability of the framing member. The minimum net web thickness for these framing members is given by:

$$t_{wn} = 2,63 \times 10^{-3} c_1 \sqrt{\frac{\sigma_y}{5,34 + 4\left(\frac{c_1}{c_2}\right)^2}} \text{ mm}$$

where

$$c_1 = h_w - 0,8h \text{ mm}$$

h_w = web height of stringer/web frame, in mm, see Figure 2.10.5 Parameter definition for web stiffening

h = height of framing member penetrating the member under consideration (to be taken as zero if no such framing member is fitted), in mm, see Figure 2.10.5 Parameter definition for web stiffening

c_2 = spacing between supporting structure oriented perpendicular to the member under consideration, in mm, see Figure 2.10.5 Parameter definition for web stiffening

σ_y = minimum upper yield stress of the material, in N/mm².

10.14.3 In addition, the following is to be satisfied:

$$t_{wn} \geq 0,35t_{pn}\sqrt{\frac{\sigma_y}{235}}$$

where

σ_y = minimum upper yield stress of the shell plate in way of the framing member, in N/mm²

t_{wn} = net thickness of the web, in mm

t_{pn} = net thickness of the shell plate in way the framing member, in mm.

10.14.4 To prevent local flange buckling of welded profiles, the following are to be satisfied:

(a) The flange width, b_f , in mm, is not to be less than five times the net thickness of the web, t_{wn} .

(b) The flange outstand, b_o , in mm, is to meet the following requirement:

$$\frac{b_o}{t_{fn}} \leq \frac{155}{\sqrt{\sigma_y}}$$

where

t_{fn} = net thickness of flange, in mm

σ_y = minimum upper yield stress of the material, in N/mm².

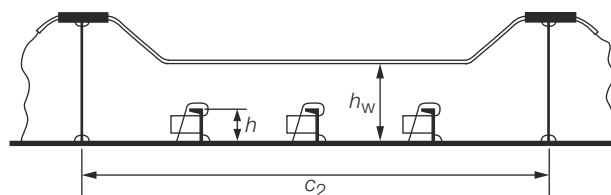

Figure 2.10.5 Parameter definition for web stiffening

10.15 Plated structures

10.15.1 Plated structures are those stiffened plate elements in contact with the hull and subject to ice loads. These requirements are applicable to an inboard extent which is the lesser of:

- (a) web height of adjacent parallel web frame or stringer; or
- (b) 2,5 times the depth of framing that intersects the plated structure.

10.15.2 The thickness of the plating and the scantlings of attached stiffeners are to be such that the degree of end fixity necessary for the shell framing is ensured.

10.15.3 The stability of the plated structure is to adequately withstand the ice loads defined in Pt 8, Ch 2, 10.7 Pressure within the design load patch.

10.16 Corrosion/abrasion additions and steel renewal

10.16.1 Effective protection against corrosion and ice-induced abrasion is recommended for all external surfaces of the shell plating for all Polar ships.

10.16.2 The values of corrosion/abrasion additions, t_s , to be used in determining the shell plate thickness for each Polar Class are listed in *Table 2.10.6 Corrosion/abrasion additions for shell plating*.

10.16.3 Polar ships are to have a minimum corrosion/abrasion addition of $t_s = 1,0$ mm applied to all internal structures within the ice strengthened hull areas, including plated members adjacent to the shell, as well as stiffener webs and flanges.

10.16.4 Steel renewal for ice strengthened structures is required when the gauged thickness is less than $t_n + 0,5$ mm.

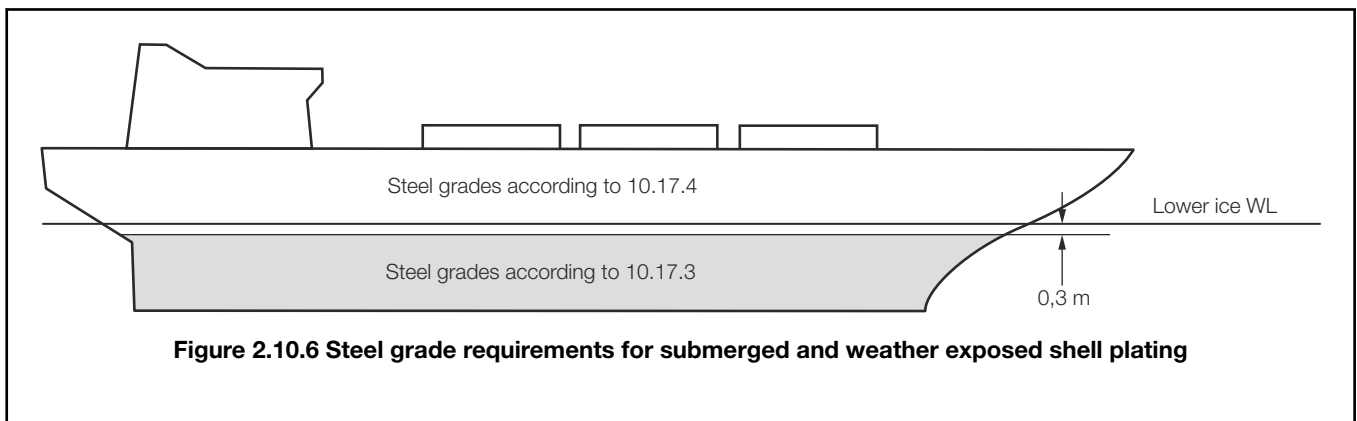

Table 2.10.6 Corrosion/abrasion additions for shell plating

Hull area	t_s , in mm					
	With effective protection			Without effective protection		
	PC1 to PC3	PC4 and PC5	PC6 and PC7	PC1 to PC3	PC4 and PC5	PC6 and PC7
Bow; Bow Intermediate Icebelt	3,5	2,5	2,0	7,0	5,0	4,0
Bow Intermediate Lower; Midbody & Stern Icebelt	2,5	2,0	2,0	5,0	4,0	3,0
Midbody and Stern Lower; Bottom	2,0	2,0	2,0	4,0	3,0	2,5

10.17 Materials

10.17.1 Plating materials for hull structures are to be not less than those given in *Table 2.10.8 Steel grades for weather exposed plating* to *Table 2.10.11 Steel grades for inboard framing members attached to weather exposed plating* based on the as-built thickness of the material, the Polar ice class notation assigned to the ship and the material class of structural members given in *Pt 8, Ch 2, 10.17 Materials 10.17.2*.

10.17.2 Material classes specified in *Table 2.2.1 Material classes and grades* in *Pt 3, Ch 2 Materials*, are applicable to polar ships regardless of the ship's length. In addition, material classes for weather and sea exposed structural members and for members attached to the weather and sea exposed plating are given in *Table 2.10.7 Material classes for structural members of polar ships*. Where the material classes in *Table 2.10.7 Material classes for structural members of polar ships* and those in *Table 2.2.1 Material classes and grades* in *Pt 3, Ch 2 Materials* differ, the higher material class is to be applied.

10.17.3 Steel grades for all plating and attached framing of hull structures and appendages situated below the level of 0,3 m below the lower waterline, as shown in *Figure 2.10.6 Steel grade requirements for submerged and weather exposed shell plating*,

are to be obtained from *Table 2.2.2 Steel grades in Pt 3, Ch 2 Materials*, based on the material class for Structural Members in *Table 2.10.7 Material classes for structural members of polar ships* above, regardless of Polar Class.

10.17.4 Steel grades for all weather exposed plating of hull structures and appendages situated above the level of 0,3 m below the lower ice waterline, as shown in *Figure 2.10.6 Steel grade requirements for submerged and weather exposed shell plating*, are to be not less than given in *Table 2.10.8 Steel grades for weather exposed plating* to *Table 2.10.10 Steel grades for weather exposed plating*.

10.17.5 Steel grades for all inboard framing members attached to weather exposed plating are to be not less than given in *Table 2.10.11 Steel grades for inboard framing members attached to weather exposed plating*. This applies to all inboard framing members as well as to other contiguous inboard members (e.g. bulkheads, decks) within 600 mm of the exposed plating.

10.17.6 Castings are to have specified properties consistent with the expected service temperature for the cast component.

Table 2.10.7 Material classes for structural members of polar ships

Structural members	Material Class
Shell plating within the bow and bow intermediate icebelt hull areas (<i>B</i> , <i>B_{II}</i>)	II
Plating materials for stem and stern frames, rudder horn, rudder, propeller nozzle, shaft brackets, ice skeg, ice knife and other appendages subject to ice impact loads	II
All weather and sea exposed SPECIAL, as defined in <i>Table 2.2.1 Material classes and grades in Pt 3, Ch 2 Materials</i> , structural members within 0,2L from FP	II
All weather and sea exposed SECONDARY and PRIMARY, as defined in <i>Table 2.2.1 Material classes and grades in Pt 3, Ch 2 Materials</i> , structural members outside 0,4L amidships	I
All inboard framing members attached to the weather and sea-exposed plating including any contiguous inboard member within 600 mm of the plating	I
Weather-exposed plating and attached framing in cargo holds of ships which by nature of their trade have their cargo hold hatches open during cold weather operations	I

Table 2.10.8 Steel grades for weather exposed plating

Thickness, <i>t</i> mm	Material Class I			
	PC1 to 5		PC6 and 7	
	MS	HT	MS	HT
$t \leq 10$	B	AH	B	AH
$10 < t \leq 15$	B	AH	B	AH
$15 < t \leq 20$	D	DH	B	AH
$20 < t \leq 25$	D	DH	B	AH
$25 < t \leq 30$	D	DH	B	AH
$30 < t \leq 35$	D	DH	B	AH
$35 < t \leq 40$	D	DH	D	DH
$40 < t \leq 45$	E	EH	D	DH

$45 < t \leq 50$	E	EH	D	DH
Note Includes weather exposed plating of hull structures and appendages, as well as their outboard framing members, situated above a level of 0,3 m below the lowest ice waterline.				

Table 2.10.9 Steel grades for weather exposed plating

Thickness, t mm	Material Class II			
	PC1 to 5		PC6 and 7	
	MS	HT	MS	HT
$t \leq 10$	B	AH	B	AH
$10 < t \leq 15$	D	DH	B	AH
$15 < t \leq 20$	D	DH	B	AH
$20 < t \leq 25$	D	DH	B	AH
$25 < t \leq 30$	E	EH, see Note 2	D	DH
$30 < t \leq 35$	E	EH	D	DH
$35 < t \leq 40$	E	EH	D	DH
$40 < t \leq 45$	E	EH	D	DH
$45 < t \leq 50$	E	EH	D	DH
Note 1. Includes weather exposed plating of hull structures and appendages, as well as their outboard framing members, situated above a level of 0,3 m below the lowest ice waterline.				
Note 2. Grades D, DH are allowed for a single strake of side shell plating not more than 1,8 m wide from 0,3 m below the lowest ice waterline.				

Table 2.10.10 Steel grades for weather exposed plating

Thickness, t mm	Material Class III					
	PC1 to 3		PC4 and 5		PC6 and 7	
	MS	HT	MS	HT	MS	HT
$t \leq 10$	E	EH	E	EH	B	AH
$10 < t \leq 15$	E	EH	E	EH	D	DH
$15 < t \leq 20$	E	EH	E	EH	D	DH
$20 < t \leq 25$	E	EH	E	EH	D	DH
$25 < t \leq 30$	E	EH	E	EH	E	EH
$30 < t \leq 35$	E	EH	E	EH	E	EH
$35 < t \leq 40$	F	FH	E	EH	E	EH
$40 < t \leq 45$	F	FH	E	EH	E	EH
$45 < t \leq 50$	F	FH	F	FH	E	EH
Note Includes weather exposed plating of hull structures and appendages, as well as their outboard framing members, situated above a level of 0,3 m below the lowest ice waterline.						

Table 2.10.11 Steel grades for inboard framing members attached to weather exposed plating

Thickness, <i>t</i> mm	Material Class III			
	PC1 to PC5		PC6 and 7	
	MS	HT	MS	HT
$t \leq 20$	B	AH	B	AH
$20 < t \leq 35$	D	DH	B	AH
$35 < t \leq 45$	D	DH	D	DH
$45 < t \leq 50$	E	EH	D	DH

10.18 Longitudinal strength – Application

10.18.1 Ice loads need only be combined with still water loads. The combined stresses are to be compared against permissible bending and shear stresses at different locations along the ship's length. In addition, sufficient local buckling strength is also to be verified.

10.19 Design vertical ice force at the bow

10.19.1 The design vertical ice force at the bow, F_{IB} , is to be taken as the lesser of $F_{IB, 1}$ or $F_{IB, 2}$:

$$F_{IB, 1} = 0,534C_L K_I 0,15 \sin^{0,2}(\gamma_s) \sqrt{DK_h} \text{ MN}$$

$$F_{IB, 2} = 1,2C_F \text{ MN}$$

where

K_I = indentation parameter

$$= \frac{K_f}{K_h}$$

K_f = for blunt bow forms:

$$= K_f = \left(\frac{2CB^{(1-e_b)}}{1+e_b} \right)^{0,9} \tan(\gamma_s)^{-0,9(1+e_b)}$$

= for wedge bow forms ($\alpha_s < 80$ deg), $e_b = 1$ and the above simplifies to:

$$= K_f = \left(\frac{\tan(\alpha_s)}{\tan^2(\gamma_s)} \right)^{0,9}$$

α_s = waterline angle measured in way of the stem at the upper ice waterline (UIWL), in degrees, see *Figure 2.10.7 Bow shape definition*

K_h = $0,01A_{wp}$ MN/m

C_L = longitudinal strength class factor from *Table 2.10.1 Class factors*

e_b = bow shape exponent which best describes the waterplane (see *Figure 2.10.7 Bow shape definition* and *Figure 2.10.8 Illustration of effect on the bow shape e_b , for $B = 20$ and $L_B = 16$).*

= An approximate e_b determined by a simple fit is acceptable

= 1,0 for a simple wedge bow form

= 0,4 to 0,6 for a spoon bow form

= 0 for a landing craft bow form

γ_s = stem angle to be measured between the horizontal axis and the stem tangent at the upper ice waterline, in degrees (buttock angle as per *Figure 2.10.2 Definition of hull angles* measured on the centreline)

$$C = \frac{1}{2 \left(\frac{L_B}{B} \right)^{eb}}$$

B = ship moulded breadth, in metres

L_B = bow length, in m, used in the equation:

$$= y = \frac{B}{2 \left(\frac{x}{L_B} \right)^{eb}} \text{ (see Figure 2.10.7 Bow shape definition and Figure 2.10.8 Illustration of effect on the bow shape } e_b, \text{ for } B = 20 \text{ and } L_B = 16 \text{)}$$

Δ = ship displacement, in kilo tonnes, not to be taken less than 10

A_{wp} = ship waterplane area, in m²

C_F = flexural failure class factor from *Table 2.10.1 Class factors*

Where applicable, draught dependent quantities are to be determined at the waterline corresponding to the loading condition under consideration.

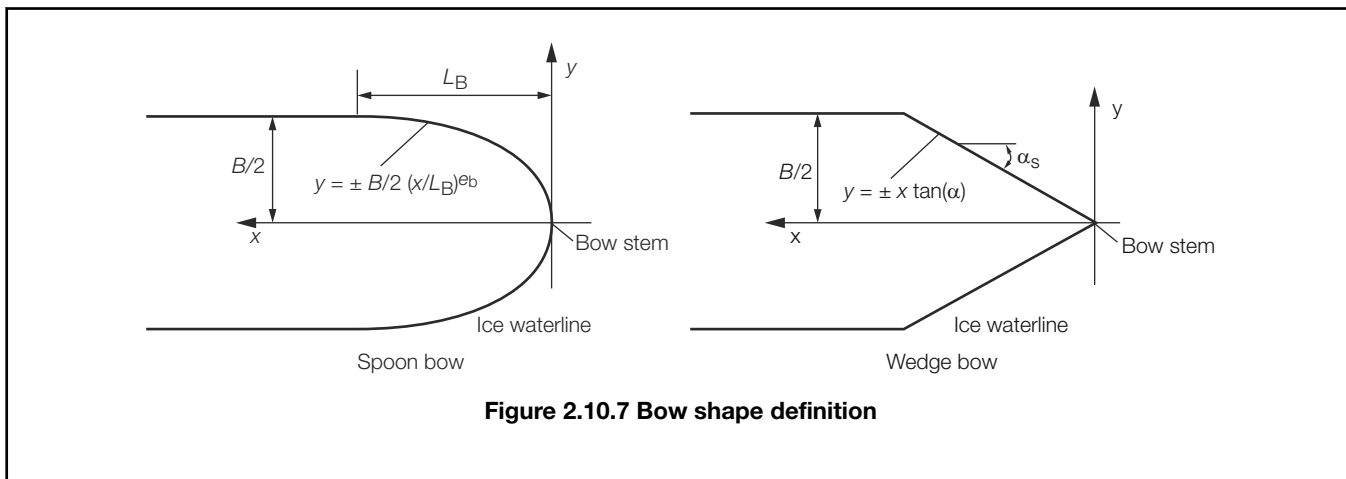

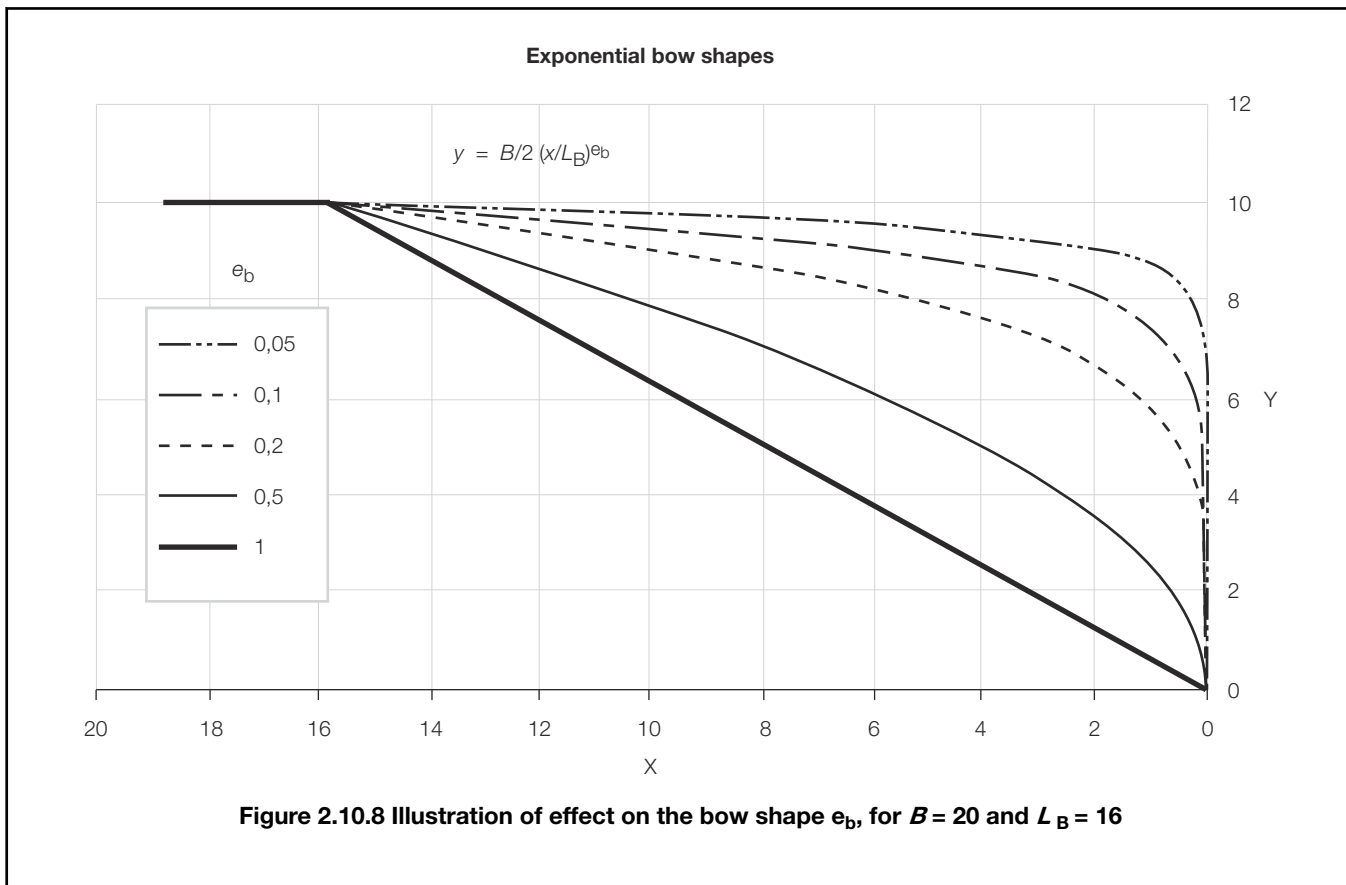

10.20 Design vertical shear force

10.20.1 The design vertical ice shear force, F_I , along the hull girder is to be taken as:

$$F_I = C_f F_{IB} MN$$

where

C_f = longitudinal distribution factor to be taken as follows:

= (a) Positive shear force

$C_f = 0,0$ between the aft end of L and $0,6L$ from aft

$C_f = 1,0$ between $0,9L$ from aft and the forward end of L

= (b) Negative shear force

$C_f = 0,0$ at the aft end of L

$C_f = -0,5$ between $0,2L$ and $0,6L$ from aft

$C_f = 0,0$ between $0,8L$ from aft and the forward end of L

Intermediate values are to be determined by linear interpolation.

10.20.2 The applied vertical shear stress, τ_a , is to be determined along the hull girder in a similar manner as in *Pt 3, Ch 4 Longitudinal Strength* by substituting the design vertical ice shear force for the design vertical wave shear force.

10.21 Design vertical ice bending moment

10.21.1 The design vertical ice bending moment, M_I , along the hull girder is to be taken as:

$$M_I = 0,1 C_m L \sin^{-0,2}(\gamma_s) F_{IB} \text{ MNm}$$

where

L = ship length as defined in Pt 3, Ch 1, 6.1 *Principal particulars 6.1.1*, but measured on the upper ice waterline (UIWL), in metres

γ_{stem} = as given in Pt 8, Ch 2, 10.19 *Design vertical ice force at the bow 10.19.1*

F_{IB} = design vertical ice force at the bow, in MN

C_m = longitudinal distribution factor for design vertical ice bending moment to be taken as follows:

= $C_m = 0,0$ at the aft end of L

= $C_m = 1,0$ between $0,5L$ and $0,7L$ from aft

= $C_m = 0,3$ at $0,95L$ from aft

= $C_m = 0,0$ at the forward end of L

= Intermediate values are to be determined by linear interpolation.

Where applicable, draught dependent quantities are to be determined at the waterline corresponding to the loading condition under consideration.

10.21.2 The applied vertical bending stress, σ_a , is to be determined along the hull girder in a similar manner as in Pt 3, Ch 4 *Longitudinal Strength*, by substituting the design vertical ice bending moment for the design vertical wave bending moment. The ship still water bending moment is to be taken as the maximum sagging moment.

10.22 Longitudinal strength criteria

10.22.1 The strength criteria provided in Table 2.10.12 *Longitudinal strength criteria* are to be satisfied. The design stress is not to exceed the permissible stress.

Table 2.10.12 Longitudinal strength criteria

Failure mode	Applied stress	Permissible stress	Permissible stress
		$\frac{\sigma_y}{\sigma_u} \leq 0,7$	$\frac{\sigma_y}{\sigma_u} > 0,7$
Tension	σ_a	$\eta \sigma_y$	$\eta 0,41(\sigma_u + \sigma_y)$
Shear	τ_a	$\frac{\eta \sigma_y}{\sqrt{3}}$	$\frac{\eta 0,41(\sigma_u + \sigma_y)}{\sqrt{3}}$
Buckling	σ_a	σ	for plating and for web plating of stiffeners
		$\frac{\sigma_c}{1,1}$	for stiffeners
	τ_a	τ_c	
Symbols			

σ_a = applied vertical bending stress, in N/mm²

τ_a = applied vertical shear stress, in N/mm²

σ_y = minimum upper yield stress of the material, in N/mm²

σ_u = ultimate tensile strength of material, in N/mm²

σ_c = critical buckling stress in compression, according to Pt 3, Ch 4 Longitudinal Strength, in N/mm²

τ_c = critical buckling stress in shear, according to Pt 3, Ch 4 Longitudinal Strength, in N/mm²

η = 0,8

10.23 Stem and stern frames

10.23.1 The stem and stern frame are to be suitably designed. The stem and stern requirements of the *Finnish-Swedish Ice Class Rules* are to be additionally considered, see Pt 8, Ch 2, 1 *Strengthening requirements for navigation in ice – Application of requirements*.

10.24 Appendages

10.24.1 All appendages are to be designed to withstand forces appropriate for the location of their attachment to the hull structure or their position within a hull area.

10.25 Local details

10.25.1 Local design details are to be suitably designed to transfer ice-induced loads to supporting structure (bending moments and shear forces).

10.25.2 The loads carried by a member in way of cut-outs are not to cause instability. Where necessary, the structure is to be stiffened.

10.26 Direct calculations

10.26.1 Direct calculations are not to be utilised as an alternative to the analytical procedures prescribed in this Section.

10.26.2 Where direct calculation is used to check the strength of structural systems, the load patch specified in Pt 8, Ch 2, 10.2 *Design ice loads – General* is to be applied.

10.27 Welding

10.27.1 All welding within ice-strengthened areas is to be of the double continuous type.

10.27.2 Continuity of strength is to be ensured at all structural connections.

■ Section 11**Machinery strengthening requirements for navigation in multi-year ice conditions – Ice Classes PC1, PC2, PC3, PC4, PC5, PC6 and PC7****11.1 Application**

11.1.1 The contents of this Section apply to main propulsion, steering gear, emergency and essential auxiliary systems essential for the safety of the ship and the survivability of the crew and systems and equipment required by assigned optional classification notations, e.g. navigational equipment associated with the notations **NAV1** or **IBS**.

11.1.2 For **PC6** and **PC7**, the requirements will be considered with respect to compliance with the *Finnish- Swedish Ice Class Rules*.

11.2 Drawings and particulars to be submitted

11.2.1 The following drawings and particulars to be submitted:

- (a) Details of the environmental conditions and the required ice class for the machinery, if different from ship's ice class.
- (b) Detailed drawings of the main propulsion machinery. Description of the main propulsion, steering, emergency and essential auxiliaries are to include operational limitations. Information on essential main propulsion load control functions.
- (c) Description detailing how main, emergency and auxiliary systems are located and protected to prevent problems from freezing, ice and snow and evidence of their capability to operate in intended environmental conditions.
- (d) Calculations and documentation indicating compliance with the requirements of this Section.

11.3 System design

11.3.1 Systems, subject to damage by freezing, are to be drainable.

11.3.2 Single screw vessels classed PC1 to PC5 inclusive are to have means provided to ensure sufficient vessel operation in the case of propeller damage including CP mechanism.

11.4 Materials exposed to sea-water

11.4.1 Materials exposed to sea-water, such as propeller blades, propeller hub and blade bolts are to have an elongation not less than 15 per cent on a test piece the length of which is five times the diameter. Charpy V impact test are to be carried out for other than bronze and austenitic steel materials. Test pieces taken from the propeller castings are to be representative of the thickest section of the blade. An average impact energy value of 20 J taken from three Charpy V tests is to be obtained at minus 10°C.

11.5 Materials exposed to sea-water temperature

11.5.1 Materials exposed to sea-water temperature are to be of steel or other approved ductile material. An average impact energy value of 20 J taken from three tests is to be obtained at minus 10°C.

11.6 Materials exposed to low air temperature

11.6.1 Materials of essential components exposed to low air temperature shall be of steel or other approved ductile material. An average impact energy value of 20 J taken from three Charpy V tests is to be obtained at 10°C below the lowest design temperature. See also *Provisional Rules for the Winterisation of Ships, July 2015*.

11.7 Propeller ice interaction

11.7.1 These Rules cover open and ducted type propellers situated at the stern of a vessel having controllable pitch or fixed pitch blades. Ice loads on bow propellers and pulling type propellers are to receive special consideration. The given loads are expected, single occurrence, maximum values for the whole ship's service life for normal operational conditions. These loads do not cover off-design operational conditions, for example when a stopped propeller is dragged through ice. These Rules apply also for azimuthing (geared and podded) thrusters considering loads due to propeller ice interaction. However, ice loads due to ice impacts on the body of azimuthing thrusters are not covered by this Section.

11.7.2 The loads given in Pt 8, Ch 2, 11.7 *Propeller ice interaction* are total loads (unless otherwise stated) during ice interaction and are to be applied separately (unless otherwise stated) and are intended for component strength calculations only. The different loads given here are to be applied separately.

11.7.3 F_b is a force bending a propeller blade backwards when the propeller mills an ice block while rotating ahead. F_f is a force bending a propeller blade forwards when a propeller interacts with an ice block while rotating ahead.

11.8 Ice class factors

11.8.1 Table 2.11.1 *Propeller ice loads index* lists the design ice thickness and ice strength index to be used for estimation of the propeller ice loads.

Table 2.11.1 Propeller ice loads index

Ice Class	H_{ice} , in metres	S_{ice}	S_{qice}
PC1	4,0	1,2	1,15
PC2	3,5	1,1	1,15
PC3	3,0	1,1	1,15
PC4	2,5	1,1	1,15
PC5	2,0	1,1	1,15
PC6	1,75	1,0	1,00
PC7	1,5	1,0	1,00

where

H_{ice} = ice thickness for machinery strength design

S_{ice} = ice strength index for blade ice force

S_{qice} = ice strength index for blade ice torque

11.9 Design ice loads for open propeller

11.9.1 The maximum backward blade force, F_b , is to be taken as:

when $D < D_{limit}$

$$F_b = -27S_{ice}(nD)^{0,7} \left(\frac{EAR}{Z}\right)^{0,3} D^2 \text{ kN}$$

when $D \geq D_{limit}$

$$F_b = -23S_{ice}(nD)^{0,7} \left(\frac{EAR}{Z}\right)^{0,3} (H_{ice})^{1,4} D \text{ kN}$$

where

$$D_{limit} = 0,85 (H_{ice})^{1,4}$$

n = the nominal rotational speed in rev/sec (at MCR free running condition) for CP-propeller and 85 per cent of the nominal rotational speed (at MCR free running condition) for a FP-propeller (regardless of driving engine type).

11.9.2 F_b is to be applied as a uniform pressure distribution to an area on the back (suction) side of the blade for the following load cases:

- (a) Load case 1: from 0,6R to the tip and from the blade leading edge to a value of 0,2 chord length
- (b) Load case 2: a load equal to 50 per cent of the F_b is to be applied on the propeller tip area outside of 0,9R

(c) Load case 5: for reversible propellers, a load equal to 60 per cent of the F_b is to be applied from 0,6R to the tip and from the blade trailing edge to a value of 0,2 chord length.

See load cases 1, 2, and 5 in *Table 2.11.4 Load cases for open propeller*.

11.9.3 The maximum forward blade force, F_f , is to be taken as:

when $D < D_{\text{limit}}$

$$F_f = 250 \left(\frac{EAR}{Z} \right) D^2 \text{ kN}$$

when $D \geq D_{\text{limit}}$

$$F_f = 500 \left(\frac{1}{1 - \frac{d}{D}} \right) H_{\text{ice}} \left(\frac{EAR}{Z} \right) D \text{ kN}$$

where

$$D_{\text{limit}} = \left(\frac{2}{1 - \frac{d}{D}} \right) H_{\text{ice}} \text{ m}$$

d = propeller hub diameter, in metres

D = propeller diameter, in metres

EAR = expanded blade area ratio

Z = number of propeller blades.

11.9.4 F_f is to be applied as a uniform pressure distribution to an area on the face (pressure) side of the blade for the following load cases:

- (a) Load case 3: from 0,6R to the tip and from the blade leading edge to a value of 0,2 chord length.
- (b) Load case 4: a load equal to 50 per cent of F_f is to be applied on the propeller tip area outside of 0,9R.
- (c) Load case 5: for reversible propellers a load equal to 60 per cent of F_f is to be applied from 0,6R to the tip and from the blade trailing edge to a value of 0,2 chord length.

See load cases 3, 4, and 5 in *Table 2.11.4 Load cases for open propeller*.

11.9.5 The blade spindle torque, Q_{smax} , around the spindle axis of the blade fitting is to be calculated both for the load cases described in *Pt 8, Ch 2, 11.9 Design ice loads for open propeller 11.9.1* and *Pt 8, Ch 2, 11.9 Design ice loads for open propeller 11.9.3* for F_h and F_f . If these spindle torque values are less than the default value given below, the default minimum value is to be used:

$$Q_{\text{smax}} = 0,25Fc_{0,7} \text{ kNm}$$

where

$C_{0,7}$ = length of the blade chord at 0,7R radius, in m

F = F_h or F_f whichever has the greater absolute value.

11.9.6 The maximum propeller ice torque applied to the propeller is to be taken as:

when $D < D_{\text{limit}}$

$$Q_{\text{max}} = 105 \left(1 - \frac{d}{D} \right) S_{\text{qice}} \left(\frac{P_{0,7}}{D} \right)^{0,16} \left(\frac{t_{0,7}}{D} \right)^{0,6} (nD)^{0,17} D^3 \text{ kNm}$$

when $D \geq D_{\text{limit}}$

$$Q_{\max} = 202 \left(1 - \frac{d}{D}\right) S_{\text{qice}} H_{\text{ice}}^{1,1} \left(\frac{P_{0,7}}{D}\right)^{0,16} \left(\frac{t_{0,7}}{D}\right)^{0,6} (nD)^{0,17} D^{1,9} \text{ kNm}$$

where

$$D_{\text{limit}} = 1,81 H_{\text{ice}}$$

S_{qice} = ice strength index for blade ice torque

$P_{0,7}$ = propeller pitch at 0,7R, in m

= for CP propellers, $P_{0,7}$ is to correspond to MCR in bollard condition. If not known, $P_{0,7}$ is to be taken as $0,7P_{0,7n}$

$P_{0,7n}$ = propeller pitch at MCR free running condition

$t_{0,7}$ = maximum thickness at 0,7R

n = the rotational propeller speed, in rev/sec, at bollard condition. If not known, n is to be taken as follows:
for CP propellers and FP propellers driven by turbine or electric motor = n_n

= for FP propellers driven by diesel engine = $0,85n_n$

n_n = the nominal rotational speed at MCR, free running condition.

11.9.7 The maximum propeller ice thrust applied to the shaft is to be taken as:

$$T_f = 1,1 F_t$$

$$T_b = 1,1 F_b$$

11.10 Design ice loads for ducted propellers

11.10.1 The maximum backward blade force, F_b is to be taken as:

when $D < D_{\text{limit}}$

$$F_b = -9,5 S_{\text{ice}} \left(\frac{EAR}{Z}\right)^{0,3} (nD)^{0,7} D^2$$

when $D \geq D_{\text{limit}}$

$$F_b = -66 S_{\text{ice}} \left(\frac{EAR}{Z}\right)^{0,3} (nD)^{0,7} D^{0,6} (H_{\text{ice}})^{1,4}$$

where

$$D_{\text{limit}} = 4 H_{\text{ice}}$$

n = as in Pt 8, Ch 2, 11.9 Design ice loads for open propeller 11.9.1.

11.10.2 F_b is to be applied as a uniform pressure distribution to an area on the back side for the following load cases:

- (a) Load case 1: on the back of the blade from 0,6R to the tip and from the blade leading edge to a value of 0,2 chord length
- (b) Load case 5: for reversible rotation propellers a load equal to 60 per cent of F_b is applied on the blade face from 0,6R to the tip and from the blade trailing edge to a value of 0,2 chord length.

See load cases 1 and 5 in Table 2.11.5 Load cases for ducted propeller.

11.10.3 The maximum forward blade force, F_f , is to be taken as:

when $D \leq D_{\text{limit}}$

$$F_f = 250 \left(\frac{EAR}{Z} \right) D^2 \text{ kN}$$

when $D > D_{\text{limit}}$

$$F_f = 500 \left(\frac{EAR}{Z} \right) D \left(\frac{1}{1 - \frac{d}{D}} \right) H_{\text{ice}} \text{ kN}$$

where

$$D_{\text{limit}} = \left(\frac{2}{1 - \frac{d}{D}} \right) H_{\text{ice}} \text{ m.}$$

11.10.4 F_f is to be applied as a uniform pressure distribution to an area on the face (pressure) side for the following load cases:

- (a) Load case 3: on the blade face from $0,6R$ to the tip and from the blade leading edge to a value of $0,5$ chord length.
- (b) Load case 5: a load equal to 60 per cent F_f is to be applied from $0,6R$ to the tip and from the blade leading edge to a value of $0,2$ chord length.

See load cases 3 and 5 in *Table 2.11.5 Load cases for ducted propeller.*

11.10.5 The maximum propeller ice torque, Q_{max} , applied to the propeller is to be taken as:

when $D \leq D_{\text{limit}}$

$$Q_{\text{max}} = 74 \left(1 - \frac{d}{D} \right) \left(\frac{P_{0,7}}{D} \right)^{0,16} \left(\frac{t_{0,7}}{D} \right)^{0,6} (nD)^{0,17} S_{qice} D^3 \text{ kNm}$$

when $D > D_{\text{limit}}$

$$Q_{\text{max}} = 141 \left(1 - \frac{d}{D} \right) \left(\frac{P_{0,7}}{D} \right)^{0,16} \left(\frac{t_{0,7}}{D} \right)^{0,6} (nD)^{0,17} S_{qice} D^{1,9} H_{\text{ice}}^{1,1} \text{ kNm}$$

where

$$D_{\text{limit}} = 1,8 H_{\text{ice}} \text{ in metres}$$

n = the rotational propeller speed, in rps, at bollard condition. If not known, n is to be taken as follows: for CP propellers and FP propellers driven by turbine or electric motor = n_n

= for FP propellers driven by diesel engine = $0,85n_n$

n_n = the nominal rotational speed at MCR at free running condition

$P_{0,7}$ = for CP propellers, propeller pitch, $P_{0,7}$ is to correspond to MCR in bollard condition. If not known, $P_{0,7}$ is to be taken as $0,7P_{0,7n}$

$P_{0,7n}$ = propeller pitch at MCR free running condition.

11.10.6 The spindle torque for CP-mechanism design, Q_{smax} , around the spindle axis of the blade fitting is to be calculated for the load case described in *Pt 8, Ch 2, 11.7 Propeller ice interaction.* If these spindle torque values are less than the default value given below, the default value is to be used:

$$Q_{\text{smax}} = 0,25 F C_{0,7} \text{ kNm}$$

where

$C_{0,7}$ = the length of the blade section at $0,7R$

F = F_b or F_f whichever has the greater absolute value.

11.10.7 The maximum propeller ice thrust (applied to the shaft at the location of the propeller) is to be taken as:

$$T_f = 1,1F_f$$

$$T_b = 1,1F_b.$$

11.11 Design loads on propulsion line – Torque

11.11.1 The propeller ice torque excitation for shaft line dynamic analysis is to be described by a sequence of blade impacts which are of half sine shape and occur at the blade. The torque due to a single blade ice impact as a function of the propeller rotation angle is to be taken as:

when $\phi = 0 \dots \alpha_i$

$$Q(\phi) = C_q Q_{\max} \sin\left(\phi \left(\frac{180}{\alpha_i}\right)\right)$$

when $\phi = \alpha_i \dots 360$

$$Q(\phi) = 0$$

where

C_q = as given in Table 2.11.2 Torque load factors

α_i = as given in Table 2.11.2 Torque load factors.

Table 2.11.2 Torque load factors

Torque excitation	Propeller-ice interaction	C_q	α_i
Case 1	Single ice block	0,50	45
Case 2	Single ice block	0,75	90
Case 3	Single ice block	1,00	135
Case 4	Two ice blocks with 45 degree phase in rotation angle	0,50	45

11.11.2 The total ice torque is obtained by summing the torque of single blades taking into account the phase shift $360^\circ/Z$. The number of propeller revolutions during a milling sequence is to be obtained with the formula:

$$N_Q = 2H_{ice}$$

where

number of impacts = $Z N_Q$ see Figure 2.11.1 The shape of the propeller ice torque excitation for 45, 90, 135 degrees single blade impact sequences and 45 degrees double blade impact sequence (two ice pieces) on a four bladed propeller.

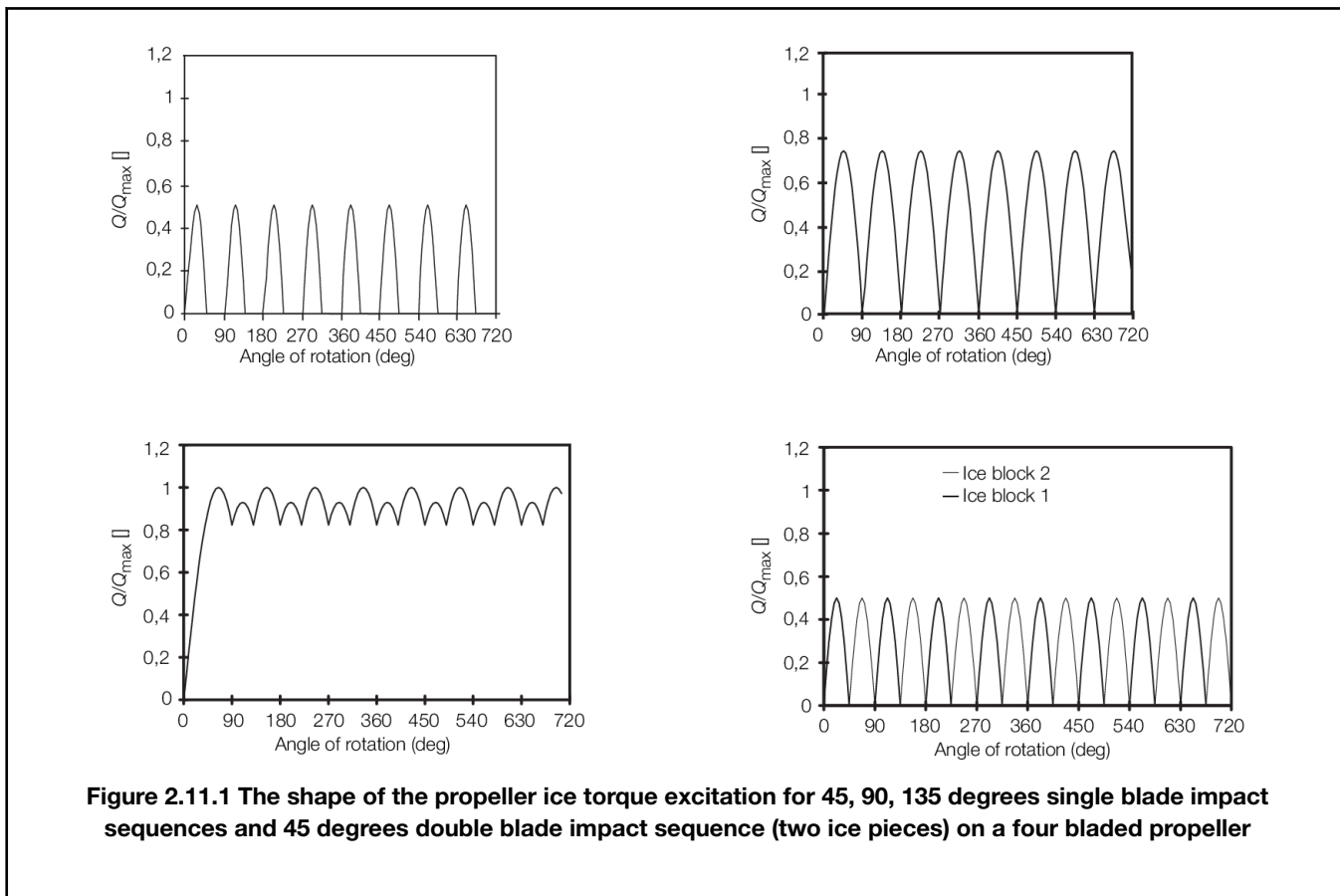

Figure 2.11.1 The shape of the propeller ice torque excitation for 45, 90, 135 degrees single blade impact sequences and 45 degrees double blade impact sequence (two ice pieces) on a four bladed propeller

11.11.3 The milling torque sequence duration is not valid for pulling bow propellers, which are subject to special consideration. The response torque at any shaft component is to be analysed considering excitation torque $Q(\phi)$ at the propeller, actual engine torque, Q_e , and mass elastic system. Where Q_e is the actual maximum engine torque at considered speed.

11.11.4 The design torque, Q_r , of the shaft component is to be determined by means of torsional vibration analysis of the propulsion line. Calculations are to be carried out for all excitation cases given above and the response is to be applied on top of the mean hydrodynamic torque in bollard condition at considered propeller rotational speed.

11.12 Design loads on propulsion line – Maximum response thrust

11.12.1 The maximum thrust along the propeller shaft line is to be calculated with the formulae below. The factors 2,2 and 1,5 take into account the dynamic magnification due to axial vibration. Alternatively, the propeller thrust magnification factor may be calculated by dynamic analysis.

Maximum shaft thrust forwards

$$T_r = T_n + 2,2T_f \text{ kN}$$

Maximum shaft thrust backwards

$$T_r = 1,5T_b \text{ kN}$$

where

T_n = hydrodynamic propeller bollard thrust, in kN. If not known, T_n is to be as given in *Table 2.11.3 Propeller thrust factor*

T_f = maximum forward propeller ice thrust, in kN.

Table 2.11.3 Propeller thrust factor

Propeller type	T_n
CP propellers (open)	$1,25T$
CP propellers (ducted)	$1,10T$
FP propellers driven by turbine or electric motor	T
FP propellers driven by diesel engine (open)	$0,85T$
FP propellers driven by diesel engine (ducted)	$0,75T$
Symbols	
<p>T = nominal propeller thrust at MCR at free running open water conditions</p>	

Table 2.11.4 Load cases for open propeller

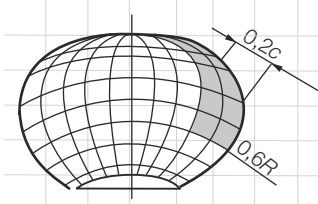
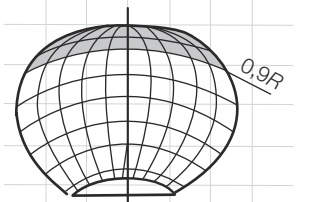
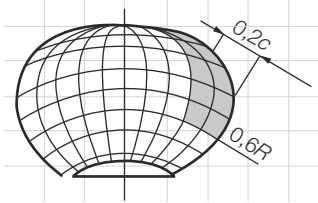
Load case	Force	Loaded area	Right handed propeller blade seen from back
Load case 1	F_b	Uniform pressure applied on the back of the blade (suction side) to an area from $0,6R$ to the tip and from the leading edge to $0,2$ times the chord length.	
Load case 2	50% of F_b	Uniform pressure applied on the back of the blade (suction side) on the propeller tip area outside of $0,9R$ radius.	
Load case 3	F_f	Uniform pressure applied on the blade face (pressure side) to an area from $0,6R$ to the tip and from the leading edge to $0,2$ times the chord length.	

Load case 4	50% of F_f	Uniform pressure applied on propeller face (pressure side) on the propeller tip area outside of $0,9R$ radius.	
Load case 5	60% of F_f or F_b whichever is the greater	Uniform pressure applied on propeller face (pressure side) to an area from $0,6R$ to the tip and from the trailing edge to $0,2$ times the chord length.	

Table 2.11.5 Load cases for ducted propeller

Load case	Force	Loaded area	Right handed propeller blade seen from back
Load case 1	F_b	Uniform pressure applied on the back of the blade (suction side) to an area from $0,6R$ to the tip and from the leading edge to $0,2$ times the chord length	
Load case 3	F_f	Uniform pressure applied on the blade face (pressure side) to an area from $0,6R$ to the tip and from the leading edge to $0,5$ times the chord length	
Load case 5	60% of F_f or F_b	Uniform pressure applied on propeller face (pressure side) to an area from $0,6R$ to the tip and from the trailing edge to $0,2$ times the chord length	

11.13 Design loads on propulsion line – Blade failure load for both open and nozzle propellers

11.13.1 The force is acting at $0,8R$ in the weakest direction of the blade and at a spindle arm of $2/3$ of the distance of axis of blade rotation of leading and trailing edge whichever is the greatest. The blade failure load is to be taken as:

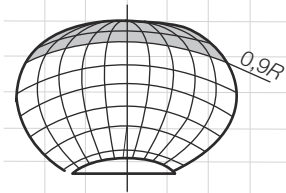
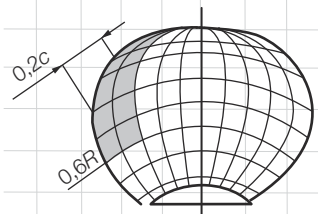
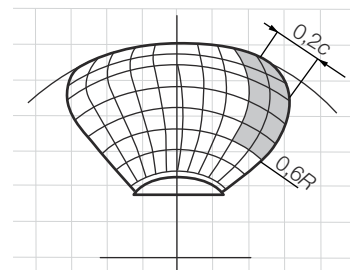
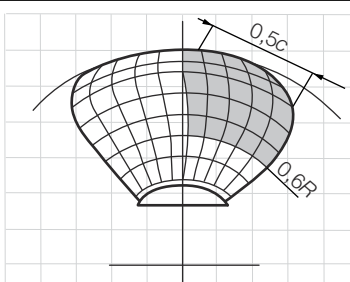
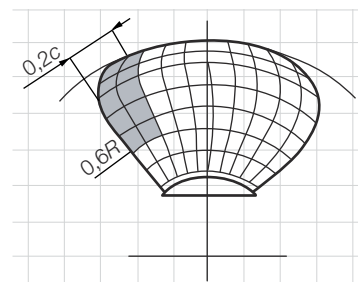
$$F_{ex} = \frac{0,3c t^2 \sigma_{ref}}{0,8D - 2r} \times 10^3 \text{ kN}$$

where

$$\sigma_{ref} = 0,6\sigma_{0,2} + 0,4\sigma_u$$

$\sigma_{0,2}$ and σ_u = representative values for the blade material

c , t and r = the actual chord length, thickness and radius of the cylindrical root section of the blade at the weakest section outside root fillet and typically will be at the termination of the fillet into the blade profile.

11.14 Design – Design principle

11.14.1 The strength of the propulsion line is to be designed:

- (a) for maximum loads in *Pt 8, Ch 2, 11.7 Propeller ice interaction*;
- (b) such that the plastic bending of a propeller blade will not cause damage in other propulsion line components;
- (c) with sufficient fatigue strength.

11.15 Design – Azimuthing main propulsors

11.15.1 In addition to the above requirements, special consideration will be given to the loading cases which are extraordinary for propulsion units when compared with conventional propellers. Estimation of the loading cases must reflect the operational realities of the ship and the thrusters. In this respect, for example, the loads caused by impacts of ice blocks on the propeller hub of a pulling propeller are to be considered. Also, loads due to thrusters operating in an oblique angle to the flow are to be considered. The steering mechanism, the fitting of the unit and the body of the thruster is to be designed to withstand the loss of a blade without damage. The plastic bending of a blade is to be considered in the propeller blade position, which causes the maximum load on the studied component.

11.15.2 Azimuth thrusters are also to be designed for estimated loads due to thruster body/ice interaction as in *Pt 8, Ch 2, 10.24 Appendages*.

11.16 Blade design – Maximum blade stresses

11.16.1 Blade stresses are to be calculated using the backward and forward loads given in sub-Sections *Pt 8, Ch 2, 11.9 Design ice loads for open propeller* and *Pt 8, Ch 2, 11.10 Design ice loads for ducted propellers*. The stresses are to be calculated with recognised and well documented FE-analysis or another acceptable alternative method. The stresses on the blade are not to exceed the allowable stresses, σ_{all} , for the blade material given below. The calculated blade stress for the maximum ice load is to comply with the following:

$$\sigma_{calc} < \sigma_{all} = \frac{\sigma_{ref}}{S}$$

where

$$S = 1,5$$

σ_{ref} = reference stress, defined as:

$$= 0,7\sigma_u$$

$$= 0,6 \sigma_{0,2} + 0,4\sigma_u \text{ whichever is less}$$

σ_u and $\sigma_{0,2}$ = representative values for the blade material.

11.17 Blade design – Blade edge thickness

11.17.1 The blade edge thicknesses, t_{ed} , and tip thickness t_{tip} , are to be greater than t_{edge} given by the following formula:

$$t_{edge} \geq x S S_{ice} \sqrt{\frac{3P_{ice}}{\sigma_{ref}}}$$

where

x = distance from the blade edge measured along the cylindrical sections from the edge and is to be 2,5 per cent of chord length, however not to be taken greater than 45 mm.

= In the tip area (above 0,975R radius) x is to be taken as 2,5 per cent of 0,975R section length and is to be measured perpendicularly to the edge, however not to be taken greater than 45 mm.

S = safety factor

= 2,5 for trailing edges

= 3,5 for leading edges

= 5,0 for tip

S_{ice} = as given in Pt 8, Ch 2, 11.8 Ice class factors

P_{ice} = ice pressure

= 16 MPa for leading edge and tip thickness

σ_{ref} = as given in Pt 8, Ch 2, 11.16 Blade design – Maximum blade stresses.

11.17.2 The requirement for edge thickness is to be applied for leading edge and in case of reversible rotation open propellers also for the trailing edge. Tip thickness refers to the maximum measured thickness in the tip area above 0,975R radius. The edge thickness in the area between the position of maximum tip thickness and edge thickness at 0,975 radius has to be interpolated between edge and tip thickness value and smoothly distributed.

11.18 Prime movers

11.18.1 The main engine is to be capable of being started and running the propeller with the CP in full pitch.

11.18.2 Provisions are to be made for heating arrangements to ensure ready starting of the cold emergency power units at an ambient temperature applicable to the Polar class of the ship.

11.18.3 Emergency power units are to be equipped with starting devices with a stored energy capability of at least three consecutive starts at the design temperature in Pt 8, Ch 2, 11.18 Prime movers 11.18.2. The source of stored energy is to be protected to preclude critical depletion by the automatic starting system, unless a second independent means of starting is provided. A second source of energy is to be provided for an additional three starts within 30 min., unless manual starting can be demonstrated to be effective.

11.19 Machinery fastening loading accelerations

11.19.1 Essential equipment and main propulsion machinery supports are to be suitable for the accelerations as indicated in the following. Accelerations are to be considered acting independently.

11.19.2 The maximum longitudinal impact acceleration, a_l , at any point along the hull girder is to be taken as:

$$a_l = \left(\frac{F_{IB}}{\Delta} \right) \left\{ [1, 1 \tan(\gamma + \varphi)] + \frac{7H}{L} \right\} \text{ m/s}^2$$

where

F_{IB} = vertical impact force, defined in Pt 8, Ch 2, 10.19 Design vertical ice force at the bow

H = distance from the waterline to the point being considered, in metres

L = length between perpendiculars, in metres

Φ = maximum friction angle between steel and ice, normally taken as 10, in degrees

γ = bow stem angle at waterline, in degrees

Δ = Displacement.

11.19.3 The combined vertical impact acceleration, a_v , at any point along the hull girder, is to be taken as:

$$a_v = 2,5 \left(\frac{F_{IB}}{\Delta} \right) F_X \text{ m/s}^2$$

where

= 1,3 at the FP

= 0,2 at midships

= 0,4 at the AP

= 1,3 at the AP for vessels conducting icebreaking astern

= intermediate values are to be determined by linear interpolation.

11.19.4 The combined transverse impact acceleration, a_t , at any point along hull girder, is to be taken as:

$$a_t = 3F_i \left(\frac{F_X}{\Delta} \right) \text{ m/s}^2$$

where

F_X = 1,5 at the FP

= 0,25 at midships

= 0,5 at the AP

= 1,5 at the AP for vessels conducting icebreaking astern

= intermediate values are to be determined by linear interpolation

F_i = total force normal to shell plating in the bow area due to oblique ice impact, defined in Pt 8, Ch 2, 10.19
Design vertical ice force at the bow.

11.20 Auxiliary systems

11.20.1 Machinery is to be protected from the harmful effects of ingestion or accumulation of ice or snow. Where continuous operation is necessary, means are to be provided to purge the system of accumulated ice or snow.

11.20.2 Means are to be provided to prevent damage due to freezing, to tanks containing liquids.

11.20.3 Vent pipes, intake and discharge pipes and associated systems are to be designed to prevent blockage due to freezing or ice and snow accumulation.

11.21 Sea inlets and cooling water systems

11.21.1 Cooling water systems for machinery that are essential for the propulsion and safety of the vessel, including sea chest inlets, are to be designed for the environmental conditions applicable to the ice class.

11.21.2 At least two sea chests are to be arranged as ice boxes for classes **PC1** to **PC5** inclusive. The calculated volume for each of the ice boxes is to be at least 1 m³ for every 750 kW of the total installed power. For **PC6** and **PC7**, there is to be at least one ice box located preferably near centreline.

- 11.21.3 Ice boxes are to be designed for an effective separation of ice and venting of air.
- 11.21.4 Sea inlet valves are to be secured directly to the ice boxes. The valves are to be a full bore type.
- 11.21.5 Ice boxes and sea bays are to have vent pipes and are to have shut off valves connected directly to the shell.
- 11.21.6 Means are to be provided to prevent freezing of sea bays, ice boxes, ship side valves and fittings above the load waterline.
- 11.21.7 Efficient means are to be provided to re-circulate cooling seawater to the ice box. The total sectional area of the circulating pipes is not to be less than the area of the cooling water discharge pipe.
- 11.21.8 Detachable gratings or manholes are to be provided for ice boxes. Manholes are to be located above the deepest load line. Access is to be provided to the ice box from above.
- 11.21.9 Openings in ship sides for ice boxes are to be fitted with gratings, or holes or slots in shell plates. The net area through these openings is to be not less than 5 times the area of the inlet pipe. The diameter of holes and width of slot in shell plating is to be not less than 20 mm. Gratings of the ice boxes are to be provided with a means of clearing. Clearing pipes are to be provided with screw-down type non-return valves.

11.22 Ballast tanks

- 11.22.1 Efficient means are to be provided to prevent freezing in fore and after peak tanks and wing tanks located above the waterline and where otherwise found necessary. See Pt 8, Ch 2, 2.1 General 2.1.3 and *The Provisional Rules for the Winterisation of Ships, Ch 1, 3.2 Documentation 3.2.1.*

11.23 Ventilation system

- 11.23.1 The air intakes for machinery and accommodation ventilation are to be located on both sides of the ship.
- 11.23.2 Accommodation and ventilation air intakes are to be provided with means of heating.
- 11.23.3 The temperature of the inlet air provided to machinery from the air intakes is to be suitable for the safe operation of the machinery.

11.24 Alternative design

- 11.24.1 As an alternative a comprehensive design study may be submitted and may be requested to be validated by an agreed test programme.

■ Section 12 Requirements for Icebreaker(+)

12.1 Scope

- 12.1.1 Where the notation **Icebreaker(+)** is assigned, the arrangement, powering and dimensions of the hull structure and propulsion machinery are to be determined based on the operational profile that corresponds to that which the icebreaker is envisaged to undertake.

- 12.1.2 The assignment of the notation **Icebreaker(+)** is in addition to the requirements of Pt 8, Ch 2, 10 *Hull strengthening requirements for navigation in multi-year ice conditions – Ice Classes PC1, PC2, PC3, PC4, PC5, PC6, PC7 and Icebreaker* and Pt 8, Ch 2, 11 *Machinery strengthening requirements for navigation in multi-year ice conditions – Ice Classes PC1, PC2, PC3, PC4, PC5, PC6 and PC7* and is assigned in addition to the ice class notations given in Table 2.1.1 *Polar class descriptions*. See Pt 8, Ch 2, 1.5 *Icebreakers*.

12.2 Operational profile

- 12.2.1 The operational profile to be used for the basis of assignment of the notation **Icebreaker(+)** is to be derived from the icebreaker's function, as selected from Pt 8, Ch 2, 12.4 *Typical operational profiles*.

- 12.2.2 The operational profile is only used to select a design basis. It is the responsibility of the Owner and/or Builder to determine the appropriate operational profile of the icebreaker.

12.3 Information to be submitted

12.3.1 For assignment of the notation **Icebreaker(+)**, the operational envelope criteria are to be submitted, which may include the following information, where applicable:

- (a) the level icebreaking capability, in terms of speed and ice thickness;
- (b) the turning capability in level ice, in terms of diameter and ice thickness; and
- (c) the ramming capability, in terms of speed and ice condition.

12.3.2 In addition to the information submitted in *Pt 8, Ch 2, 12.3 Information to be submitted 12.3.1*, a scenario document, which is design specific, is required to document the operational profile and is to include details of the scenarios selected for deriving and applying ice loads.

12.3.3 The scenario document is to address the requirements in *Pt 8, Ch 2, 10 Hull strengthening requirements for navigation in multi-year ice conditions – Ice Classes PC1, PC2, PC3, PC4, PC5, PC6, PC7 and Icebreaker* and *Pt 8, Ch 2, 11 Machinery strengthening requirements for navigation in multi-year ice conditions – Ice Classes PC1, PC2, PC3, PC4, PC5, PC6 and PC7* and provide justification for deviation from those requirements.

12.3.4 The following is to be contained within the submitted scenario document:

- (a) icebreaker function;
- (b) details of ice conditions assumed;
- (c) operational scenarios for hull and propulsion machinery;
- (d) identification of critical hull and propulsion machinery scenarios;
- (e) description of propulsion machinery and/or hull loading areas with reasons for selection;
- (f) proposed strengthening standards for each load area;
- (g) arrangement of propulsion devices;
- (h) derived load data-based full scale measurement or other predictive means; and
- (i) details of, and justification for, deviation from the Rules.

12.3.5 In addition to the information submitted in *Pt 8, Ch 2, 12.3 Information to be submitted 12.3.4*, an ice pressure plan that indicates the design ice pressures used for the determination of the hull structure is to be submitted.

12.3.6 The operational envelope criteria is to be placed on board the ship.

12.4 Typical operational profiles

12.4.1 Typical operational profiles may be derived from the icebreaker function. Primary icebreaker functions are described in *Table 2.12.1 Primary icebreaker functions*. These functions are to form the basis of operational scenarios as required in *Pt 8, Ch 2, 12.3 Information to be submitted 12.3.4*. Where an alternative function is selected a description of the icebreaker's operational functions is to be included in the scenario document.

Table 2.12.1 Primary icebreaker functions

Primary function	General description	Assumed criticality of operation
Escort	Engaged in icebreaker fleet operations in ice, patrol and search/rescue missions Breaking channel for supporting other ships, close manoeuvring, freeing of beset vessels and, where appropriate, towing vessels	May attempt to follow easiest course when operating alone. Search and rescue operations are undertaken within the bounds of safe operation to the icebreaker and escorted ship

Research	Engaged in independent operations in ice, including deployment of scientists and research equipment Breaking of channels to reach scientific/ research bases and escort of ships for re-supply purposes	May re-route or re-schedule to avoid perceived difficult ice conditions
Support	Engaged in independent or icebreaker fleet operations in ice, supply/transit runs to support offshore installations Ice management activities which may include breaking of ice floes and engagement in ice defence of offshore operations/installations	May actively break large/strong ice features to defend the installation

12.5 General arrangement

12.5.1 Consideration is to be given to the protection of fuel tanks and other tanks with harmful substances, both in terms of thermal insulation and ice impact protection. A double bottom and double side tanks are to be fitted as specified in *Pt 4, Ch 9, 1.2 Application and ship arrangement 1.2.17*. However, double side tanks may not be required for small icebreakers (typically less than 60 m), nor complete double bottom height in way of complex hullform arrangements in the fore and aft ends or heeling tanks.

12.5.2 Consideration is to be given to minimise transom sterns, as these hinder the icebreaker’s ability to back in ice, and in particular the navigation of ice ridges. A transom stern should not normally extend below the Upper Ice Waterline. Where this cannot be avoided, the transom should be kept as narrow as possible and the scantlings of plating and stiffeners are to be as required for the stern section.

12.5.3 The requirements are based on an effective icebreaker bow form. Icebreaking angles vary depending on the icebreaking form; however, in general, the bow stem angle is not to be greater than 45°, and the bow waterline angle not greater than 40°, see *Figure 2.12.1 Icebreaker stem angles*. Where flare of the side shell amidships is proposed, it is recommended that the slope of the side be at least 8°.

12.5.4 Ice arresters (ice skeg) are recommended for all icebreakers to prevent riding up of the bow and submergence of the aftermost deck edge.

12.5.5 For icebreakers provided with a heel inducing system, it is recommended that the depth of the icebreaker be such that immersion of the deck edge does not occur when the ship, whilst floating at the Upper Ice Waterline, is heeled to an angle of 5° greater than the nominal capacity of the system or 15°, whichever is the greater.

12.5.6 For icebreakers intended to navigate continuously in thick multi-year ice, i.e. PC1, PC2 and PC3, and in relation to the icebreaker function, consideration should be given to the mass of the icebreaker to enable effective ice breaking.

12.5.7 For icebreakers installed with podded propulsion or azimuth thrusters, see the *Provisional Rules for Stern First Ice Class Ships*.

12.6 Hull strength

12.6.1 An ice pressure plan is to be submitted as required in *Pt 8, Ch 2, 12.3 Information to be submitted 12.3.5*. The ice pressure is to consider the adjustment of area factors for additional ice interaction scenarios as well as the crushing failure class factors due to the increased impact speed as well as application with due cognisance of low displacements.

12.6.2 The area factors associated with the ice pressure plan in *Pt 8, Ch 2, 12.6 Hull strength 12.6.1* are, as a minimum, to comply with the hull area factors given in *Table 2.10.3 Hull area factors (AF)* for the ice class assigned.

12.7 Propulsion and machinery arrangements

12.7.1 Icebreakers are to be equipped with means of propulsion that meet the operational envelope criteria. Demonstration of suitable propulsion power for the operational envelope criteria as specified in *Pt 8, Ch 2, 12.3 Information to be submitted 12.3.1*, as appropriate, may be from any of the following or other appropriate methods:

- (a) theoretical formulation, as given in *Pt 8, Ch 2, 12.7 Propulsion and machinery arrangements 12.7.2* and *Pt 8, Ch 2, 12.7 Propulsion and machinery arrangements 12.7.3*;

- (b) technical investigations based on engineering principles;
- (c) service experience at the operating ice conditions; and
- (d) ice model tests.

Consideration should be given to the applicable speed in relation to the ice thickness, as provided in *Pt 8, Ch 2, 12.3 Information to be submitted 12.3.1*, and the operational profile.

12.7.2 The propulsion power, at 2 knots, for icebreakers may be expressed as follows, where the ice thickness and icebreaker breadth form the dominant role:

$$P = 1000B^{0,7}h \left(1,4 - \frac{2h}{B}\right) \text{ kW}$$

where

B = breadth of icebreaker, as defined in *Pt 3, Ch 1, 6.1 Principal particulars*, in metres

h = nominal level ice thickness, in metres.

12.7.3 The propulsion power, at 2 knots, for icebreakers may be expressed as follows, where *Pt 8, Ch 2, 12.7 Propulsion and machinery arrangements 12.7.3* is modified to account for the hullform:

$$P = 96 \left(\frac{\theta_{\text{stem}}}{\arctan\left(\frac{h}{B}\right)} + \frac{\alpha_{\text{waterline}}}{\arctan\left(\frac{B}{L}\right)} \right) B^{0,7}h \left(1,4 - \frac{2h}{B}\right) \text{ kW}$$

Where

L = length of icebreaker, as defined in *Pt 3, Ch 1, 6.1 Principal particulars*, in metres

B = breadth of icebreaker, as defined in *Pt 3, Ch 1, 6.1 Principal particulars*, in metres

h = nominal level ice thickness, in metres.

θ_{stem} = stem angle, see *Figure 2.12.1 Icebreaker stem angles*

$\alpha_{\text{waterline}}$ = waterline angle, see *Figure 2.12.1 Icebreaker stem angles*

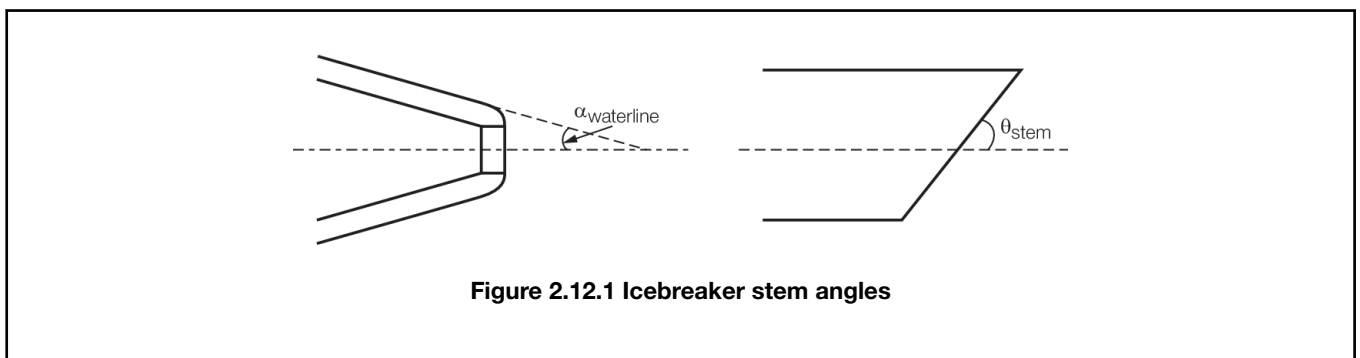

Figure 2.12.1 Icebreaker stem angles

12.7.4 The formulae given in *Pt 8, Ch 2, 12.7 Propulsion and machinery arrangements 12.7.2* and *Pt 8, Ch 2, 12.7 Propulsion and machinery arrangements 12.7.3* are based on the broad fleet of icebreaker designs ($60 \leq L \leq 140\text{m}$ and $15 \leq B \leq 28$) and level ice thicknesses ($0,5 \leq h \leq 2\text{m}$). Adjustments may therefore be required to account for specific propulsion arrangements, alternative speed criteria, size-mass effects, other L/B ratios and ice conditions.

12.7.5 The propulsion power condition is to be considered, whereby 100 per cent of the rated ahead speed is available for a minimum of 30 minutes. A minimum astern power condition is to be considered, whereby 70 per cent of the rated astern speed is available for a minimum of 30 minutes.

12.7.6 Consideration should be given to machinery protection against over-speeding, excess torque, overloading and overheating.

12.7.7 Propulsion system redundancy is to be considered. Where a machinery redundancy (**PMR**, **SMR** or **PSMR**) notation is to be assigned in addition to an **Icebreaker(+)** notation, the requirements of *Pt 5, Ch 22 Propulsion and Steering Machinery Redundancy* are to be complied with.

12.7.8 Icebreakers are prone to additional noise and vibration. Conditions when icebreaking are to be considered when applying the rules, see *Pt 5, Ch 1, 4.3 Resilient mountings* and *Pt 7, Ch 13 On-shore Power Supplies*.

12.8 Rudder and steering arrangements

12.8.1 Rudder posts, rudder horns, solepieces, rudder stocks and pintles are to be dimensioned in accordance with *Pt 3, Ch 6 Aft End Structure* and *Pt 3, Ch 13 Ship Control Systems* as appropriate. The speed used in the calculations is to be the maximum service speed or that given in *Table 2.12.2 Minimum speeds*, whichever is the greater.

Table 2.12.2 Minimum speeds

Ice thickness, m	Ship speed, kn
1	25
1,5	27
2	29
3	31

12.8.2 In the case of twin rudders operated by a single steering gear, provision is to be made for each rudder to be readily disconnected and secured.

12.8.3 Rudders should be located inboard, clear of the aft end, and as low as practicable to reduce the impact of ice.

12.9 Towing

12.9.1 For escort icebreakers, arrangements for towing are to be provided, including a notch shape in the stern and provision of two chock pipes and two bits. Consideration should be given for stern plating and framing to be strengthened to withstand impact loads for escorted ship collisions, as well as the propulsion and steering gear layout and protection from contact with bulbous bows. See *Pt 4, Ch 3, 7 Towing arrangements*.

12.10 Winterisation

12.10.1 Where a winterisation notation is assigned in compliance with the Provisional Rules for the Winterisation of Ships, the following features are to be additionally considered:

- (a) bridge wings are to be fully enclosed;
- (b) ice removal measures, through heating arrangements, are to be provided to access routes to towing equipment for escort icebreakers;
- (c) provisions for evacuation onto ice;
- (d) additional search lights for mooring, astern manoeuvring and towing operations;
- (e) consideration of a red (flashing) navigation light to be used to indicate when an escort icebreaker is stopped;
- (f) provisions to prevent water freezing in water and fluid systems, including research laboratories and services;
- (g) consideration of ice accretion in damage condition; and
- (h) protection from ice accretion by enclosed aft walkways for icebreakers with an exposed aft deck.

© Lloyd's Register Group Limited 2016
Published by Lloyd's Register Group Limited
Registered office (Reg. no. 08126909)
71 Fenchurch Street, London, EC3M 4BS
United Kingdom