

Thrust force evaluation for a ROV (Remont Operating Vehicle) propeller

A Sabau

Constanta Maritime University, Faculty of Electromechanics,
104 Mircea cel Batran Street, 900663 Constanta, Romania,

E-mail: ady1_sabau@yahoo.com

Abstract. The underwater vehicles operated remotely, known from the specialized literature under the name of ROV are common and are intensively used in the maritime industry. Depending on the area of use, ROV must satisfy numerous constructive and functional requirements, which are difficult to achieve in practice and the simulation is a challenging alternative. The big challenge is the simulation of the thrust force generated by the propeller. The present work aims to present such a simulation realized with the Ansys Fluid Dynamics software package. The simulation presented uses a 3D model of an asymmetrical propeller in the duct, having as reference the T100 propeller marketed by Blue Robotics. The fluid volume extracted after the model was made was separated into two domains one static and other rotating around the propeller, which was discretized using the default grid generator. The solution was obtained under stationary conditions using only the flow equations together with the standard k- ϵ model for turbulence modelling. The calculation was made for rotation speed values in the working domain. In the end, using the facilities of the program, the thrust force of the propeller was calculated. The obtained results were compared with the experimental measurements and critical analysis will be done.

1. Introduction

The remotely operated underwater vehicles, ROV are common and are intensively used in the maritime industry (shipyards, marine drilling rigs, underwater prospecting vessels, underwater structures, etc.) due to the many possibilities it offers, but mainly as a replacement for the divers. They perform multiple tasks from simple supervision to complex repair and assembly operations under the most difficult conditions, high depth, narrow spaces, low lighting. Underwater vehicles come in a variety of shapes and sizes, most of that is used as inspection vehicles and are directed and supplied from the surface by cable. Depending on the area of use, they must satisfy numerous constructive and functional requirements, which are difficult to achieve in practice. Numerical simulation, using various free or paid software offers an easy working tool to improve this type of vehicle. The results obtained for optimizing the body shape are numerous and promising. There is a good agreement between the results obtained by simulation and the experimental measurements performed on models [1, 2]. The big challenge, however, is the simulation of the thrust force generated by the propeller. There are also tests in this area but the results are not as good. Many methods and models were adopted, for propellers investigation [3, 4] in principal for the marine open propellers, and after that is also been extended to ducted propellers.



The present work aims to present a simulation realized with the Ansys CFX software package. These programs are well known by the specialists in the field for their performances in simulating the flow phenomena in the most diverse fields of mechanical engineering.

2. Theoretical background

The equations used for modelling the physical phenomena in this process are the usual ones for solving this kind of problems, Reynolds Averaged Navier-Stokes equations, in conjunction with standard k- ε equations the most common and stable eddy viscosity turbulent models [5].

This choice was made taking into account the available computing resources, the particularities of the problem and the complexity of the geometry, after performing a large number of tests with similar or better models. The assumptions made for solving the equations were stationary conditions, constant temperature, not buoyance and the fluid was considered incompressible, Newtonian and isotropic (density $\rho = \text{const.}$, viscosity $\mu = \text{const.}$) with a velocity field $U_i = \bar{U}_i + u_i$. The $\bar{U}_i = 1/\Delta t \int U_i dt$ is the averaged velocity, and u_i is time-varying component of velocity $1/\Delta t \int u_i dt = 0$.

The equations used are:

- Continuity equation:

$$\frac{\partial U_i}{\partial x_i} = 0 \quad (1)$$

- Momentum equation:

$$\rho \left(\frac{\partial U_i U_j}{\partial x_j} \right) = -\frac{\partial p'}{\partial x_i} + \frac{\partial}{\partial x_j} \left[\mu_{eff} \left(\frac{\partial U_i}{\partial x_j} + \frac{\partial U_j}{\partial x_i} \right) \right], \quad (2)$$

$$\mu_{eff} = \mu + \mu_t, \quad p' = p + \frac{2}{3} \rho k. \quad (3)$$

- Transport equation for standard k- ε :

The turbulence kinetic energy k , and its rate of dissipation ε , are obtained from the following equations:

$$\rho \frac{\partial (k U_j)}{\partial x_j} = \frac{\partial}{\partial x_j} \left[\left(\mu + \frac{\mu_t}{\sigma_k} \right) \frac{\partial k}{\partial x_j} \right] + G_k - \rho \varepsilon, \quad (3)$$

$$\rho \frac{\partial (\varepsilon U_j)}{\partial x_j} = \frac{\partial}{\partial x_j} \left[\left(\mu + \frac{\mu_t}{\sigma_\varepsilon} \right) \frac{\partial \varepsilon}{\partial x_j} \right] + \frac{\varepsilon}{k} C_{1\varepsilon} G_k + \frac{\varepsilon^2}{k} \rho C_{2\varepsilon}, \quad (4)$$

$$\mu_t = \rho C_\mu \frac{k^2}{\varepsilon}, \quad (5)$$

where G_k represents the generation of turbulence kinetic energy due to the mean velocity gradients, $C_{1\varepsilon}$, $C_{2\varepsilon}$, and C_μ are constants, σ_k and σ_ε are the turbulent Prandtl numbers μ_t is turbulent viscosity and μ_{eff} effective viscosity.

The numerical calculation scheme used was simplex, with pressure corrections, with two-order upwind schemes for pressure and momentum equations and 1 order schemes for the k- ε model.

3. 3D model and program settings

The presented simulation uses a 3D model of an asymmetrical propeller in the duct, having as reference the T100 propeller marketed by BlueRobotics as presented in figure 1.

3.1. 3D model

The 3D model of the propeller (figure 2) was made using a scanner and after that, the result is corrected in Space Claim designer, the new models' generator in Ansys package. The unnecessary detail, small faces, chamfers, blends, gaps, and misaligned entities are removed to achieve a good quality mesh and reduce the simulation effort and dimension of the model. A large number of curved surfaces with complicated geometry and intersection area represented a huge challenge. Due to the complexity, most of the intersection areas between surfaces required corrections that only be done manually and this whose very difficult and niggled.



Figure 1. T100 thruster by BlueRobotics.

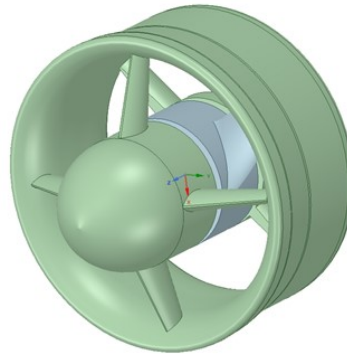

Figure 2. The 3D model of T100 thruster.

The discretization strategy was chosen following the specificity of the problem. The fluid volume extracted after the model was made was separated into two domains one static and other rotating around the propeller, which was discretized, using the default grid generator. The two part a meshed separately by cause of memory limitation. The generated mesh is hybrid whit about 13 million cells that are preponderant tetrahedral 80% and the rest is pyramidal and prismatic (wedge). Duct and static part because the complexity of the geometry imposed a very fine grid and many correction procedures. The results are presented in figures 3 and 4.

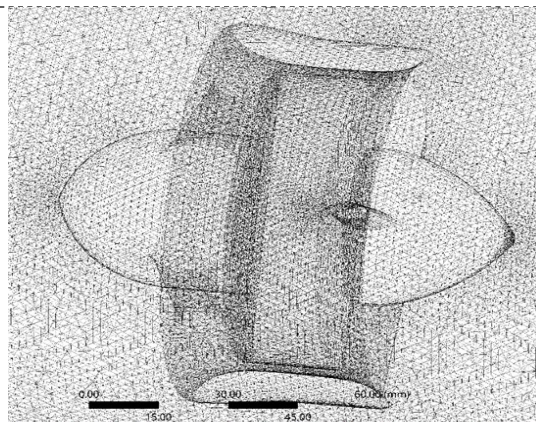

Figure 3. The static part mesh.

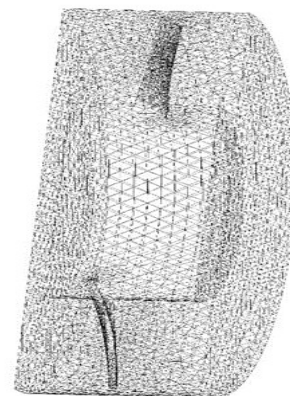

Figure 4. The rotating part mesh.

3.2. Program settings

The problem is structured in the two fluid domains (water at 20°C) one is static and the next around the propeller is rotating with constant speed, in the interval 300-4000rpm in both directions around the z-axis.

The boundary condition was defined in conformity with the recommendation for this type of problem:

- Inlet condition – imposed total pressure, normal flow direction and medium turbulence (5%)
- Outlet condition – are definite “Open” with imposed relative pressure, normal flow direction and medium turbulence (5%). This option forces the program to recalculate the parameter on the outer surface at every time step.
- Wall condition is set as implicit “no-slip”

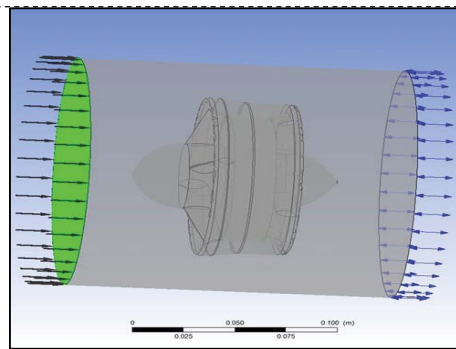

Figure 5. Boundary condition.

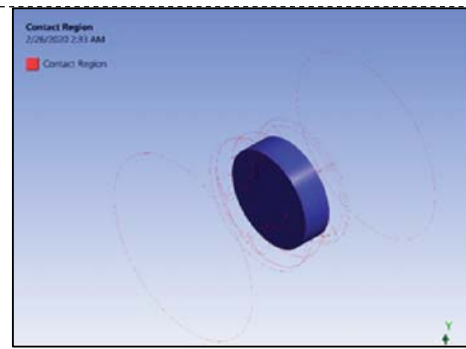

Figure 6. The Interface between the two domains.

The interface model defines the way the solver models the physics flow across the interdomain regions. For this problem “General Connection” was chosen. This interface model is a powerful way to connect regions and is used to apply a frame change at the interface between rotor and stator and connect the non-matching grids. Under these conditions to reduce the computational effort “Frozen rotor” was set and “Specified pitch angles” as the condition. This model produces a steady-state solution to the multiple frames of reference problem, with some account of the interaction between the two frames. The quasi-steady approximation involved becomes small when the through flow speed is large relative to the machine speed at the interface. Frozen Rotor analysis is most useful when the circumferential variation of the flow is large relative to the component pitch. This model requires the least amount of computational effort and is accurate when steady-state calculations are doing.

For numerical solutions “High order” advection scheme is set, for continuity and momentum equations and “First order” for the turbulence model.

The working cases have been dimensioned taking into account the computational resource, so that the program runs completely in the memory of the computer, without performing write operations on disk, only in case of saving the data.

4. Results

4.1. Simulation results

The calculation was done modifying only rotational speed in the interval 300-4200rpm in both directions. The chosen step was about 250rpm, less in the vicinity of 0, when 300rpm is set and at maximum speed when 4200rpm is set, that is the minimum speed that can be set at this type of thruster. The solution was obtained under stationary, isothermal, conditions using only the flow equations (continuity and moment) together with the standard k-ε model for turbulence modelling. The

computational time was approximately 4 hours for one of the 34 cases use 136 hours of simulation time.

The most representative results are presented in figures 7, 8, 9 and 10. The rotational speed selected is representative for ROV functionality, 4200rpm is the maximum speed, 1000rpm is maneuvering speed and 3000rpm is cruise speed.

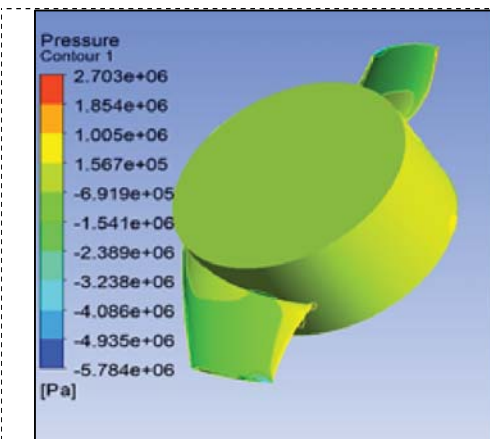

Figure 7. The pressure to the propeller surface at 4200rpm.

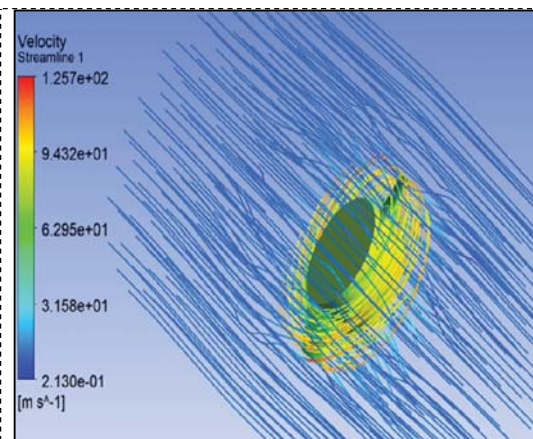

Figure 8. Stream velocity at 3000rpm.

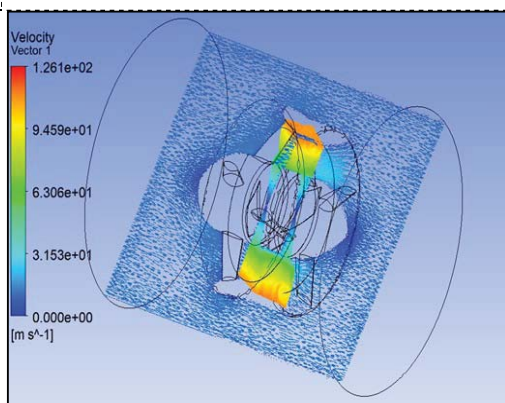

Figure 9. Velocity in the longitudinal plane of the thruster at 1000rpm.

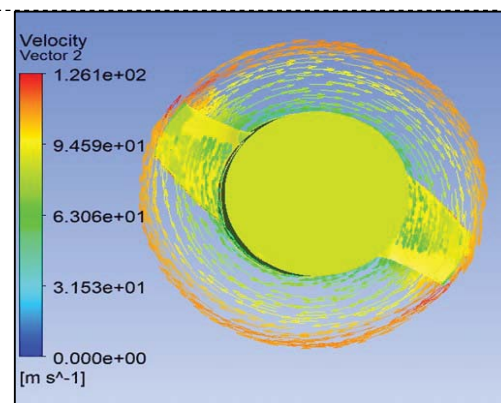
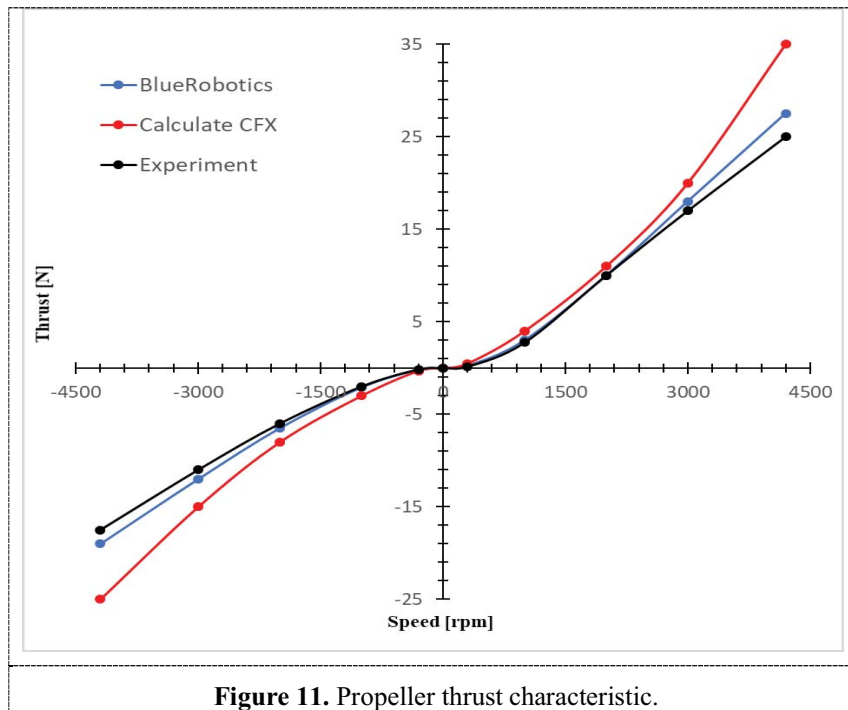

Figure 10. Velocity in the diametral pan of the thruster at 3000rpm.

In the end, using the facilities of the program, the thrust force of the propeller was calculated for both directions of rotations, the propeller being asymmetrical. The simulation results and the comparison with the experimental data available are presented in figure 11.

4.2. Experimental results

The experimental data used in the study come from two sources, one from the BlueRobotics site freely available to those interested, and the other are own measurements made in the hydrodynamic testing basin of the University. New measurements have been because the graph of the thrust force provided by BlueRobotics is a function of the electronic unit's control parameter (ECU), not of the speed as required for simulation. The results obtained from the two sources were filtered and interpolated [6] and the comparative results are shown in figure 11.



5. Conclusions

Analysing the graph in figure 11 that presents the results obtained after simulation and experimental measurements we can be concluded that the simulation can provide the thrust force generated by propellers, but the value has been overestimated especially for high speeds.

For reduced speeds (< 2000rpm) the obtained results can be used successfully for the evaluation of the propulsion characteristics.

The difference observed at high speed, can be explained mainly by the appearance of the cavity, which was not taken into account in the simulation.

At high speeds without a model for cavitation the simulation results are only informative and can be utilized only for evaluation without practical utility.

6. References

- [1] Scurtu, I.C., Panaitescu, V.N., 2019, Turbulent Flow Numerical Simulation for Unconventional Propulsion', *Revista de Chimie*, **70**(10), 3508-3511.
- [2] Sheng H, Xiang-yuan Z, Guo C., Xin Chang, 2007, CFD simulation of propeller and rudder performance when using additional thrust fins, *Journal of Marine Science and Application* **6**(4), 27-31.
- [3] Rahim M, 2019, A CFD study on the correlation between the skew angle and blade number of hydrodynamic performances of a submarine propeller, *Journal of the Brazilian Society of Mechanical Sciences and Engineering* **41**(8), 1-14.
- [4] Adan Vega, David López Martínez, 2017, Reenactment of a bollard pull test for a double propeller tugboat using computational fluid dynamics, *Ship Science & Technology*, **8**(17), 9-18, Cartagena (Colombia).
- [5] Dubbioso, G., Muscari, R., and Di Mascio, A., 2014, "Analysis of a marine propeller operating in oblique flow. part 2: Very high incidence angles, *Computers and Fluids*, **92**, 56–81.
- [6] Oanta E, Danisor A, Tamas R, 2016, Study regarding the spline interpolation accuracy of the experimentally acquired data, *Proc. SPIE* 10010, VIII, 1001007, doi: 10.1117/12.2242996.