



**Orbital Marine Power (Orkney) plc.**

**Orbital O2 2MW Tidal Turbine**

**EMEC Berth 5, Fall of Warness, Eday, Orkney**

**Project Information Summary**

**Document prepared for:**

Marine Scotland Licensing Operations Team  
Scottish Government  
Marine Laboratory  
PO Box 101  
375 Victoria Road  
Aberdeen  
AB11 9DB

European Marine Energy Centre (EMEC) Ltd.  
Old Academy  
Back Road  
Stromness  
Orkney  
KW16 3AW

**Document prepared by:**

Orbital Marine Power Ltd.  
Innovation Centre – Orkney  
Hatston Pier Road  
Kirkwall  
Orkney  
KW15 1ZL

Contact: [REDACTED]  
Email: [REDACTED]

**Revision record:**

Revision Number	Reviewed by	Date	Revision Details
1	[REDACTED]	15/06/2018	Draft issued for purposes of NRA
2	[REDACTED]	12/10/2018	Final. Issue to Marine Scotland

Copyright © 2018 Orbital Marine Power Limited  
The Copyright in the document is vested in Orbital Marine Power Limited

## CONTENTS

<b>GLOSSARY .....</b>	<b>V</b>
<b>1 INTRODUCTION.....</b>	<b>1</b>
<b>2 PROJECT LOCATION.....</b>	<b>1</b>
<b>3 OVERVIEW OF THE ORBITAL O2 .....</b>	<b>3</b>
3.1 Orbital Marine Power’s commercial demonstrator turbine .....	3
3.2 Pitch unit and rotors .....	7
3.3 Power Conversion .....	7
3.4 Power distribution .....	8
3.5 Electricity Export .....	9
3.6 Auxiliary Systems .....	9
3.7 Corrosion Protection.....	10
3.8 Orbital O2 power supply .....	10
3.9 Instrumentation and control systems.....	10
3.10 Leg retraction system.....	11
3.11 Electrical connector control .....	12
3.12 Shut down control.....	12
3.13 Communication system.....	12
<b>4 MOORING AND ANCHORING SYSTEM .....</b>	<b>14</b>
4.1 Overview of the mooring system .....	14
4.2 Anchors .....	18

4.3	Mooring Connectors .....	19
4.4	Device marking and lighting.....	20
4.5	Installation and maintenance vessel.....	21
<b>5</b>	<b>PROJECT ACTIVITIES .....</b>	<b>22</b>
5.1	Summary .....	22
5.2	Site preparation .....	22
5.3	Cable splice.....	22
5.4	Mooring system installation.....	23
5.5	Device monitoring and emergency procedures.....	27
5.6	Ongoing maintenance .....	28
5.7	Decommissioning .....	28
<b>6</b>	<b>SUMMARY .....</b>	<b>30</b>
6.1	Location of the works.....	30
6.2	Description of the works .....	30
6.3	Nature and Quantity of all deposits below Mean High Water Springs.....	30

**FIGURES**

Figure 1	SR2000 in operational mode .....	4
Figure 2	Orbital O2 in transport mode .....	4
Figure 3	Main internal systems of the Orbital O2 .....	6
Figure 4	Power Take Off configuration of Orbital O2.....	8
Figure 5	Orbital O2 mooring system operating in tide (green lines are 95mm Studlink chain, blue lines are 115mm studlink) .....	15

Figure 6 Orbital O2 mooring system at slack tide (green lines are 95mm Studlink chain, blue lines are 115mm studlink).....	15
<b>Figure 7.</b> Mooring spring.....	16
Figure 8 Schematic showing make up of each mooring line.....	17
Figure 9 Anchor basket with ballast.....	18
Figure 10. Scour protection concrete mattress .....	19
Figure 11 Orbital O2 mooring connector.....	20
Figure 12 Multi-cat workboat Green Isle towing SR2000.....	21
Figure 13. Orbital Marine Power and HV Contractors offshore on a multi-cat vessel cable jointing or “splicing” operations where static cables are permanently connected to the platform cable which supplies power and communications. ....	23
Figure 14: Multi-functional work vessels such as multi-cats are capable of precise movements of platforms in close-quarters and have capacity to tow turbines alongside owing to low well fendered free-board. ....	25
Figure 15: Installation vessel must have capacity for working with 2t buoys in tidal stream during pre-connection operations. ....	27

**TABLES**

Table 1 Proposed Orbital O2 anchor positions.....	1
Table 2 Orbital O2 design parameters.....	5
Table 3 Composition of the mooring lines.....	16
Table 4 Orbital O2 Installation programme.....	22
Table 5 Location of Orbital O2 anchors .....	30
Table 6 Permanent anchor and cable details .....	30
Table 7 Chain and Rope details.....	31
Table 8. Potential additions to the mooring lines.....	31

## Glossary

---

AC	Alternating Current
GSM	Global System for Mobile communications
HMI	Human Machine Interface
kV	Kilovolt (1000 volts)
LAN	Local Area Network
LED	Light Emitting Diode
MVA	Mega Volt Ampere
MW	Megawatt (1,000,000 watts)
PLC	Programmable Logic Controller
PTO	Power Take-Off
RIB	Rigid Inflatable Boat
RPM	Revolutions per minute
SCADA	Supervisory Control and Data Acquisition
UPS	Uninterrupted Power Supply
UTM:	Universal Transverse Mercator
V	Volt

## 1 Introduction

Orbital Marine Power (Orkney) plc ('Orbital') a wholly owned subsidiary company of Orbital Marine Power Ltd (formerly known Scotrenewables Tidal Power Limited) seek permission to install, operate and decommission their commercial demonstrator turbine, the Orbital O2 (formerly known as the SR-2000), at the EMEC Fall of Warness tidal test site in Eday, Orkney. As part of this project Orbital are required to obtain a new marine from Marine Scotland under Section 20(1) of the Marine (Scotland) Act 2010 to cover the activities associated with the project namely "the deposit of a substance or object in the sea or under the seabed".

This Project Information Document is designed to provide Marine Scotland and their consultees with information on the project to allow them to consider the application for a new Marine Licence. This document forms part of the application and is accompanied by the following additional documents:

- Marine Safety Navigational Risk Assessment; and
- Draft Project Specific Environmental Monitoring Plan.

## 2 Project location

The Orbital O2 will be located at EMEC Berth 5 and will replace the existing SR2000 machine and connect to the EMEC cable end via a riser umbilical cable as described below. The project will re-use much of the ballast used in the SR1-2000 mooring system. The location of the proposed anchors is given in Table 1 below.

The project is likely to operate up until c. end 2038, with decommissioning in 2039.

**Table 1 Proposed Orbital O2 anchor positions**

Anchor	Co-ordinates Universal Transverse Mercator (UTM)		Latitude (WGS84)	Longitude (WGS84)	Water depth CD (m)
NW	510331	6556296	59° 08.745' N	02° 49.165' W	45
NE	510491	6556417	59° 08.810' N	02° 48.997' W	40
SE	510708	6556073	59° 08.625' N	02° 48.770' W	42
SW	510529	6555983	59° 08.576' N	02° 48.958' W	45
Centre	510528	6556200	59° 08.693' N	02° 48.959' W	45
Cable anchor	510538	6556207	59° 08.697' N	02° 48.948' W	45
NW Works Extent	510131	6556614	59° 08.917' N	02° 49.374' W	

<b>Anchor</b>	<b>Co-ordinates Universal Transverse Mercator (UTM)</b>		<b>Latitude (WGS84)</b>	<b>Longitude (WGS84)</b>	<b>Water depth CD (m)</b>
NE Works Extent	510909	6556614	59° 08.916' N	02° 48.558' W	
SE Works Extent	510909	6555755	59° 08.453' N	02° 48.560' W	
SW Works Extent	510131	6555755	59° 08.454' N	02° 49.376' W	



## 3 Overview of the Orbital O2

---

The Orbital O2 project at the EMEC Fall of Warness tidal test site is composed of the following main components:

- Orbital Marine Power's commercial demonstrator turbine, the Orbital O2;
- Anchoring and mooring system; and,
- Installation, maintenance and decommissioning vessel.

The subsea cable connection to shore forms part of the EMEC facility and is therefore not considered part of the project. A description of the cable splice and umbilical line connecting the Orbital O2 with the EMEC cable is included as part of the anchoring and mooring system. Orbital propose to use the same onshore infrastructure as for the SR2000 turbine at the consented EMEC Cauldale facility. This infrastructure is therefore not discussed further here.

### 3.1 Orbital Marine Power's commercial demonstrator turbine

#### 3.1.1 Orbital O2 overview

Orbital Marine Power's Tidal Technology is a floating tidal stream energy generator. A cylindrical floating steel superstructure, which houses power conversion and auxiliary systems, provides reference and attachment for two leg structures with nacelles mounted at their ends. The leg structures have hinge attachments to the superstructure such that, with an actuation system, they can be lowered to position the nacelles and contra-rotating rotors in the optimal part of the tidal stream resource to generate power or be raised to bring the legs, nacelles and rotors to the surface for the purpose of servicing and turbine towing. Station keeping is provided to the superstructure via a multi-anchor catenary mooring system consisting of rope tethers, mooring chain and anchors. Power is exported from the turbine via a dynamic cable from the superstructure to the seabed where it connects to seabed static cabling infrastructure that exports power ashore to the EMEC substation.

The Orbital O2 turbine model will have a superstructure of 74m length and 3.8m diameter supporting two x 1MW rated turbines at the end of each leg structure providing the Orbital O2 with a rated power of c. 2MW. The generators will reach rated power at current speeds of c. 2.5m/s.

**Figure 1 SR2000 in operational mode**

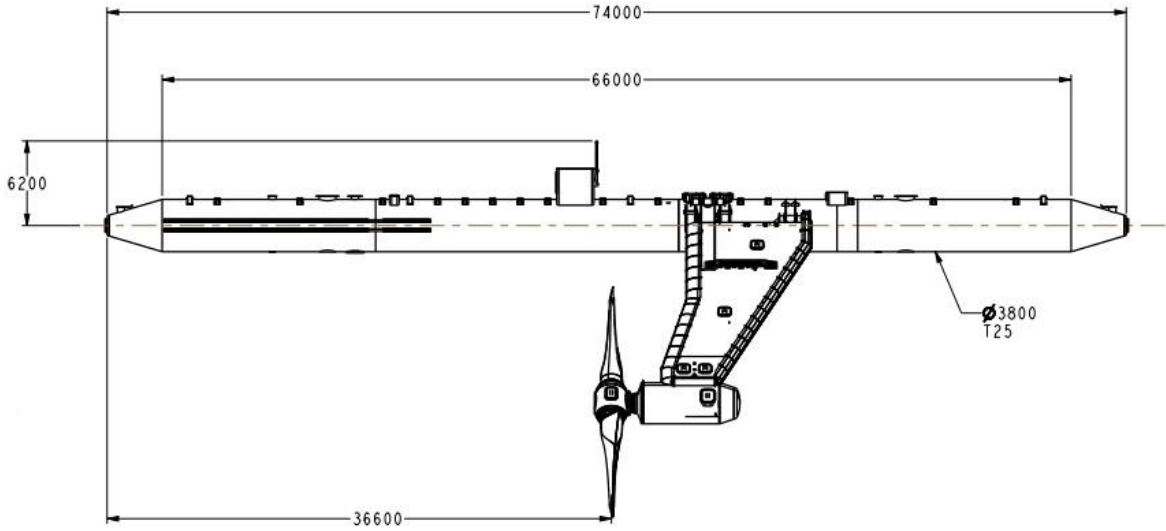

**Figure 2 Orbital O2 in transport mode**

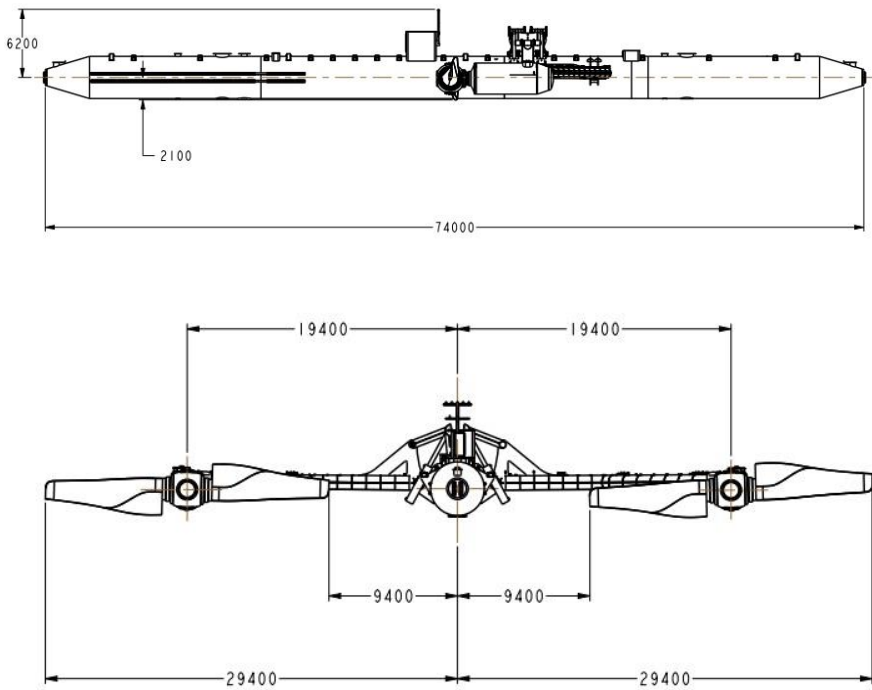

Table 2 summarises the main design parameters of the Orbital O2 commercial demonstrator turbine.

**Table 2                      Orbital O2 design parameters**

<b>Summary of device characteristics</b>	
Rated power	c. 2 MW
Displacement	600 metric Tonnes approx.
Rated current speed	2.5 m/s
Cut-in current speed	1 m/s
Shut down current speed	4.5 m/s
Hull length overall	74 m
Diameter of Hull tube	3.8 m
Depth to uppermost rotor tip during operation (rotors extended)	3.2 m
Depth to bottom rotor tip (deepest point) during operation (rotors extended)	23.2 m
Maximum depth of rotors below surface when rotors retracted	2.3 m
Maximum depth of platform below waterline	2.3 m
Height of hull tube exposed above the water surface	1.5 m
Maximum rotation speed	15 rpm
Rotor diameter	20 m
Rotor swept area	2 x 314 m <sup>2</sup>

### **3.1.2    Orbital O2 structure**

The Orbital O2 superstructure platform consists of a main tubular section with conical ends comprised of cathodically protected carbon steel. A deck structure, bollards and fendering for vessel and personnel interaction are attached to the outside. Inside the tube the main PTO equipment such as converters, transformer, switchgear and C&I panels are mounted on a skid system.

The structure is designed to provide sufficient buoyancy and hydrodynamic stability for the turbine to function efficiently. The structure is not permanently manned.

The Orbital O2 structural components are designed for a 25-year operational lifetime though certain components within the device will have a shorter lifetime. The design & construction of the structure adheres to a number of DNV-GL and other relevant offshore design standards. The structure is designed to survive rare extreme environmental conditions that occur with a very low probability, such as a 1 in 100-year wave.

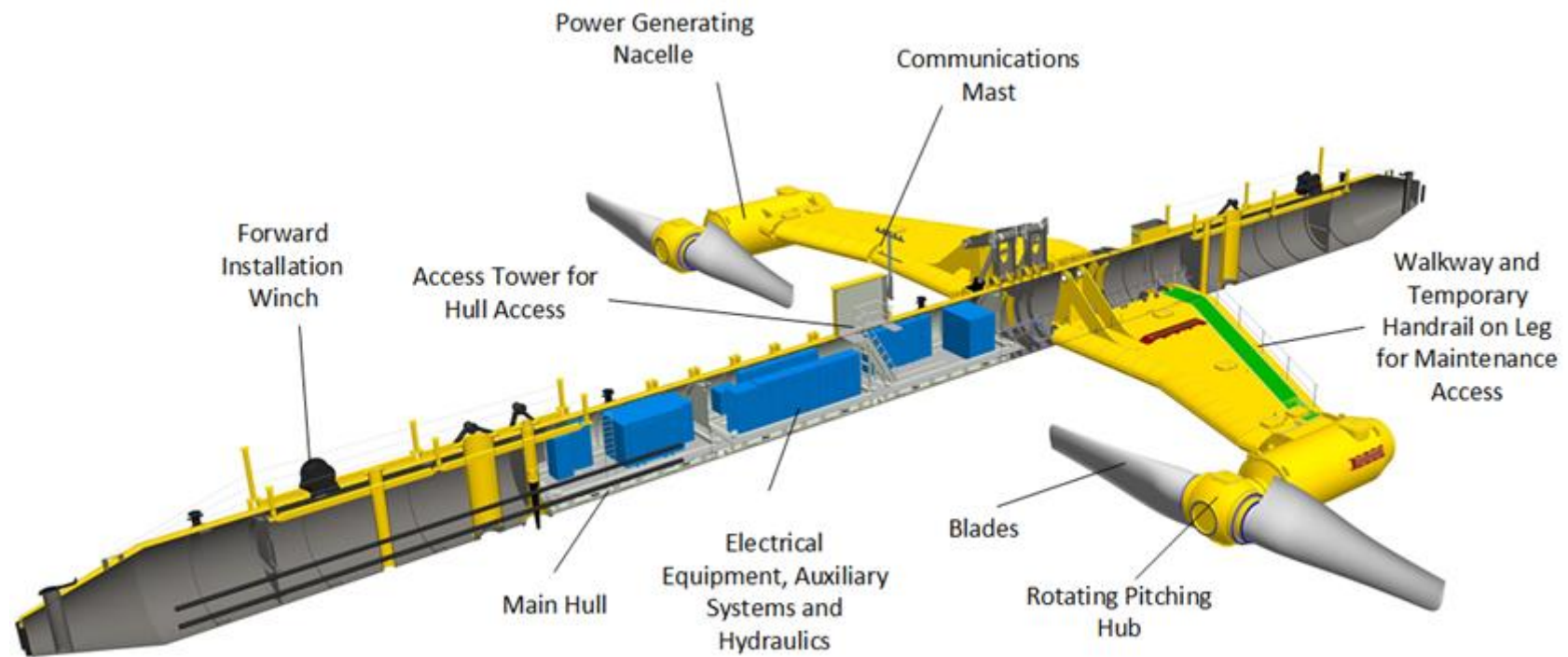

**Figure 3** Main internal systems of the Orbital O2

### 3.1.3 Nacelles

The Orbital O2 has 2 nacelles, one at the end of each retractable leg, which are mounted below the floating hull of the Orbital O2 turbine. The nacelles house the main components of the power take off (PTO), i.e. the gearbox, the high speed shaft (HSS), HSS brake and the generator as well as supporting the hub which carries the turbine blades.

The Orbital O2 nacelles are close to neutrally buoyant and can therefore be floated on and off the leg for in water assembly and removal for through-life major overhaul/maintenance. The nacelles have sufficiently large interiors for personnel access for maintenance & inspection.

### 3.2 Pitch unit and rotors

The Orbital O2 turbine features two twin bladed rotors, with blades manufactured from glass-fibre reinforced epoxy. During operation, the rotors rotate in opposing directions to support platform stability. The Orbital O2 rotors interface with a dry/non-flooded hub via a rotary pitch bearing. Exterior and interior surfaces exposed to seawater are coated with appropriate antifouling coatings<sup>1</sup> to avoid permanent build-up of marine growth.

The Orbital O2 rotors each incorporate a pitching system to control the turbine power output in both tidal flow directions by adjusting the angles of the 4 blades. The blades rotate by a nominal 180 degrees to respond to the diurnal change in tidal current direction and also dynamically feather to manage torque loads experienced by the machine.

### 3.3 Power Conversion

The Power Take-Off (PTO) system applies a controlled torque and speed on the rotor shafts which will extract the maximum amount of energy for a given tidal velocity within given limits. The rotational energy of the rotors is converted into electrical energy via a planetary gearbox directly coupled to the rotor shaft which steps up the rotational speed of the rotor to a variable speed induction generator within the nacelles. When the power approaches rated, the pitch system begins to vary the blade pitch angle in order to maintain a stable output at rated power.

The variable frequency 690V output from each generator in the nacelles is fed to the hull, where each circuit is passed through its own generator side converter. Both generator converters feed onto a common DC bus and into a single grid side converter which converts the DC into 50Hz 690Vac. The grid converter feeds through the 690V switchgear and into the main 690/11000V transformer. The converter arrangement is shown below.

---

<sup>1</sup> Likely paint choice below waterline <https://www.hempel.com/en/products/hempaguard-x7-89900>, Likely paint choice for blades <https://www.hempel.com/en/products/hempasil-x3-87500>

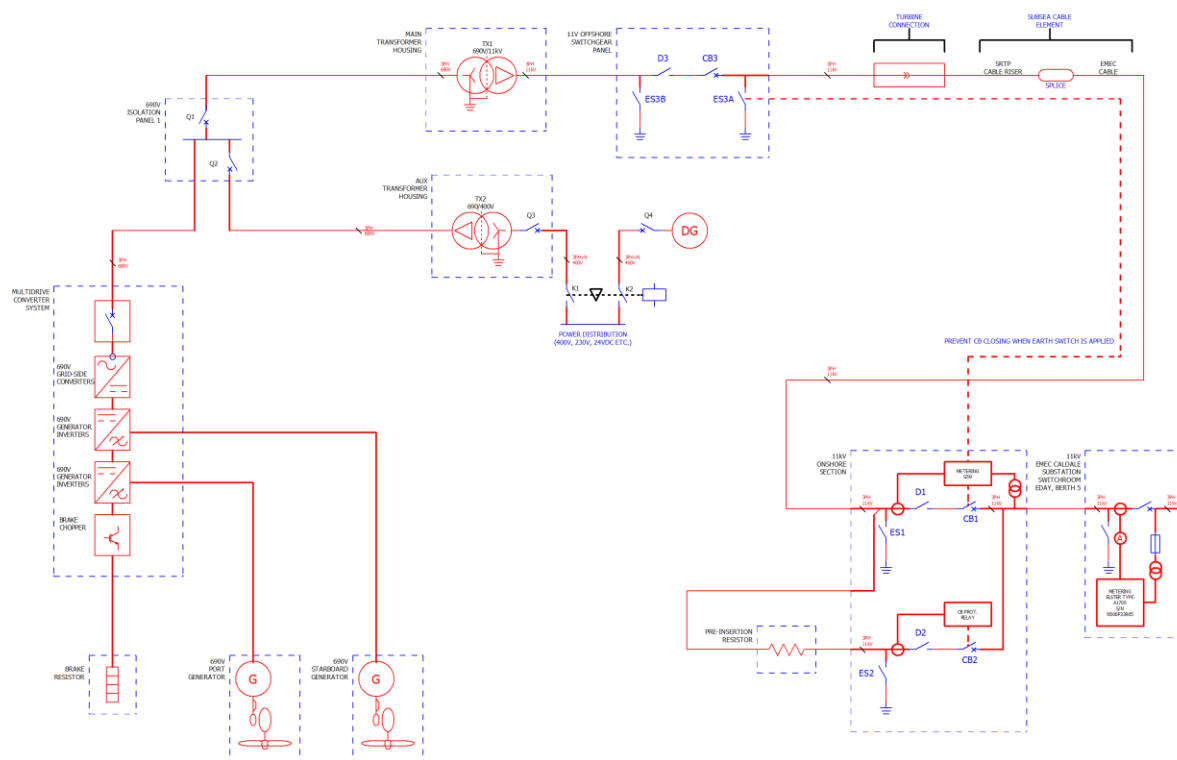

**Figure 4 Power Take Off configuration of Orbital O2**

A 400V supply to auxiliaries is taken from a separate auxiliary 690/400V transformer.

### 3.4 Power distribution

The Power distribution system includes all switchgear and power conversion equipment necessary to supply all the onboard systems. The Power Distribution system includes the following subsystems:

- A 24Vdc battery systems to supply Emergency systems including fire detection, Lighting, Control system (PLC, actuators, etc) and Control supply to Generator Variable Speed Drives.
- A 230V grid supplied system to supply Non-critical systems and systems only required when generating.
- A 400V grid supplied system to supply cooling system components including pumps and fans and Battery chargers for 24V system.
- A 690V system connected to the PTO Converters.

### 3.5 Electricity Export

The Orbital O2 will be connected through the subsea power export cable to the Grid. The onboard generation voltage will be nominally 690V which will be transformed onboard to 11kV and transmitted over the umbilical to the shore facility.

The shore facility will consist of a bank of switchgear and a Pre-Insertion Resistor (PIR). The PIR is required due to the weak grid connection at the substation. The turbine onboard transformer is energised through the PIR to limit the inrush current. If this was not limited, the grid voltage would be depressed for the duration of the inrush, by a factor outwith the limits of ENA P28.

The switchgear also allows the subsea cable to be isolated for safety when carrying out offshore operations.

### 3.6 Auxiliary Systems

The auxiliary systems onboard the Orbital O2 include all equipment and piping related cooling, firefighting and detection systems and are designed in accordance with DNVGL-ST-0164 and DNV-OS-D101 guidance for Marine and Machinery Systems and Equipment.

- Cooling water system - This includes coolant pumps, piping, keel cooler heat exchangers, and any other equipment necessary for the onboard cooling system. Water cooled components in the hull include the Variable Speed Drives and High voltage transformer. Water cooled components in the nacelle include Gearbox Oil-Water heat exchangers, and generator. The nacelle water cooling system is self-contained in the nacelle with no requirement to pump fluids to the main hull.
- Internal and external lighting - Lighting systems are provided for internal lighting in each compartment fed from battery backed supplies, Fire exit/escape route bulkhead lighting, navigational lighting, above sea-surface deck lighting for use during maintenance (e.g. walkway lighting)
- HVAC - To limit maintenance and reduce potential failure modes, active cooling systems are kept to a minimum, where possible systems rely on passive cooling and components designed for the marine environment are used. Equipment that is sensitive to damp environments are provided with anti-condensation heating when required. This includes main generators and Variable Speed Drive Cabinets
- Fire detection/fighting system - A fixed fire detection and firefighting system will be installed as per DNV-OD-D101. A detailed fire detection and shutdown procedure will ensure that the Orbital O2 will respond in a safe manner on detection of a fire.
- Charging/Black Start Connector - The Orbital O2 has an external connector to allow charging of internal batteries while the device is off-grid, e.g. from a diesel generator or vessel supply. This allows maintenance and testing of onboard systems without draining the batteries. This will also allow the Orbital O2 to be restarted in the case of a long-term loss of mains.

### **3.7 Corrosion Protection**

The corrosion protection strategy for all splash zone surfaces will involve cathodic protection in accordance with DNV-RP-B401 and suitable paint/coatings in accordance with DNV-OS-C401.

### **3.8 Orbital O2 power supply**

The Orbital O2 will contain a 24V battery system, consisting of sealed gelled electrolyte lead acid batteries which will power the instrumentation and control systems. The batteries are charged from the 400V auxiliary supply. The 400V system can be supplied by two methods:

1. When the Orbital O2 is grid connected, the chargers will be supplied from the 690/400V transformer. When generating, the energy will come from the generated power; when not generating, the energy will come from the 11kV grid connection
2. When the Orbital O2 is neither grid connected nor generating (e.g. during towing trials) for an extended period then a diesel backup generator will be employed.

### **3.9 Instrumentation and control systems**

The control system for the Orbital O2 is designed to be automated via an embedded computer based system, where a software controller will have total control of the Orbital O2. This component will monitor the operating state of the device, reading information from the different sensors and other components and manipulate this information in order to keep the system working within specified operational limits.

The operation of the system will be monitored and controlled remotely via a Supervisory Control and Data Acquisition (SCADA) system which will run permanently on a dedicated PC located onshore at Scotrenewables base in Hatston. This SCADA system will be able, amongst other things, to show the instantaneous state of the system, acknowledge warnings and alarms from it, give the operator the option to record them or not and print reports when necessary.

The PTO control system will include all systems necessary to control the extraction of energy from the tide. The control system will be flexible to allow for ongoing changes as the project progresses. As the Orbital O2 is a commercial demonstrator turbine, various sensors will monitor the environmental parameters and how the device responds to environmental inputs. This will include:

- Tidal current speed;
- Motions in the 6 degrees of freedom;
- Wave height and period;
- Rotor torque, speed and thrust;
- Rotor blade deflection;
- Mooring line loads;
- Structural forces; and
- Electrical power generation.

As part of the control system, certain parameters will be monitored solely for the safe and reliable operation of the Orbital O2. These parameters will include:



- Hydraulic pressure, temperature and reservoir levels;
- Cooling water temperature;
- Equipment space temperature/humidity;
- Generator temperature;
- Generator voltage and current; and
- Bilge level alarms.

The operation and monitoring of the system will be undertaken remotely, largely over the internet, by connecting to the SCADA computer located inside the turbine. This configuration minimises the communication issues between the PLCs (programmable logic controllers) and the SCADA. The HMI (human-machine) interface will allow operators to perform different operational and safety related actions over the system depending on the security level that each operator is given. The SCADA system will generate information about the general status of the system via process variables, alarms, reports, etc.

Integrated with the main control system, there will be several instruments which will gather important data to be used during the real time operation of the machine and to assess the performance of the system during the post-processing of the data. Apart from the main sensors that will give feedback from several parts of the system, the following instrumentation will help with safety and environmental tasks:

- ADCP (Acoustic Doppler Current Profiler) to measure the tidal speed: This will be used during operation to control power generation and to make safety decisions;
- MRU (Motion Reference Unit): Gives information about the motion of the turbine. Also useful for safe operations;
- GPS (Global Positioning System): Monitors the position of the device. Geo-fencing alarms will be set;
- Rotor variables (Torque, Speed, Thrust): Sensors give information which will be used to control generation and work within safety limits;
- Load Shackles: These will measure the tension on the mooring lines for safe operation;
- Structural forces: Strain gauges will be installed at critical locations on the structure of the device to detect stress;
- Hydraulic pressure: There will be pressure sensors in several parts of the hydraulic and cooling systems to monitor the adequate operation of those systems. These will be used to detect possible leaks in this system;
- Temperature Sensors: These will ensure that equipment is working within limits and that the environment inside the turbine is safe for possible access;
- Fire and Gas System: This system will inform about fire and gas alarms, ensuring that operation and access are safe;
- Bilge Pumps: The bilge system will detect any potentially dangerous water levels and start the bilge pumps and warn the operators.

### **3.10 Leg retraction system**

The leg retraction system will consist of a simple configuration where each leg will have sensors in charge of detecting if the legs are in the correct positions, i.e. totally retracted or extended in the

optimum position for operation. The system will have interlocks to prevent the legs being retracted when not in their “home” position.

The legs retraction system works via the control of the hydraulic pumps and valves in charge of moving the leg rams. The position of the legs will be given by tilt redundant sensors which will allow the operator to know the position of the individual legs during their deployment and retraction. The control system will perform several checks before moving the legs in order to keep this operation safe for personnel and equipment (e.g. ensuring the rotors are stopped and locked in position).

### **3.11 Electrical connector control**

The main electrical connection to the Orbital O2 is via a pull-in riser connection, where a connector ‘can’ is winched up to deck level through a small moonpool. The can is fixed such that a protective cover can be removed and the turbine-side dry mate connectors can be plugged in. A protective cover is then fixed in place to protect the connectors from the environment. This process will take less than 30 minutes.

### **3.12 Shut down control**

Device shut down will be fully automated. There will be four shut down scenarios:

1. Planned at the end of each tidal cycle;
2. Planned at cut out tidal velocity (the velocity above which generation of power is stopped due to the increased loads and strain on the structure and control system);
3. Survival shutdown of rotor above critical sea state; and
4. In case of an emergency.

There are a number of different shut down processes depending on the circumstances of the shut-down outlined below:

- Manual - in this case the operator decides to cease turbine operation or decides what state they want the turbine to be in e.g. transport mode during maintenance operations;
- Automated - the turbine control system, based on environmental information, decides if it can keep generating or not and whether to go into a controlled stop stage;
- Emergency shutdown - the device, again based on environmental information, decides that it is dangerous to operate and shuts down automatically, going into survival mode (legs up);
- Emergency stop - the device detects a risky or dangerous situation and stops the rotors, disables the drives and trips any other equipment involved in the movement of the rotors, applying the brakes and waiting for the operator to decide what to do next.

### **3.13 Communication system**

The communications system will consist of:

- Radio Frequency Link: this is a remote but short distance link which is used to perform some actions on the device without the need for personnel on board the device;

- Wireless LAN: this link connects the turbine with the router installed on shore via long range access points;
- Wired Ethernet LAN: This link uses a fibre optic connection to shore. This will be the main communication link;
- 3G: There will be at least one 3G (or 4G) modem installed in the turbine which can be used as a back-up communication route in case of a failure in the main links;
- GSM: There will be a GSM system which allows the turbine to send and receive SMS texts. This system will be used to alarm the duty managers about safety related issues in the event of a failure on the internet connection and can receive commands from the duty managers to perform actions on the system. The GSM system is backed up by an UPS (Uninterruptible Power Supply) to ensure that it remains operational in the event of a power failure.

## 4 Mooring and anchoring system

---

### 4.1 Overview of the mooring system

The mooring system for the Orbital O2 comprises of four catenary mooring lines which are moored to the seabed via four separate anchors. The mooring system has been designed in accordance with Offshore Standard DNV-OS-E301.

Two lines would be connected at both the forward and aft ends of the hull to hold the platform on station. On each tidal cycle, the platform would be held on station by one of these two lines. As the tide changes direction, the turbine will move by up to 25 m in all directions as slack in the mooring lines is taken up, with the opposite lines then holding the turbine in position. Mooring line lengths will be subject to detailed design and micrositing but will each be in the region of 225m in length.

In the highly unlikely event that a mooring line failed, any single remaining mooring line is capable of holding the platform in place.

The maximum area covered by the mooring spread will be approximately 420m x 220m.



**Figure 5** Orbital O2 mooring system operating in tide (green lines are 95mm Studlink chain, blue lines are 115mm studlink)

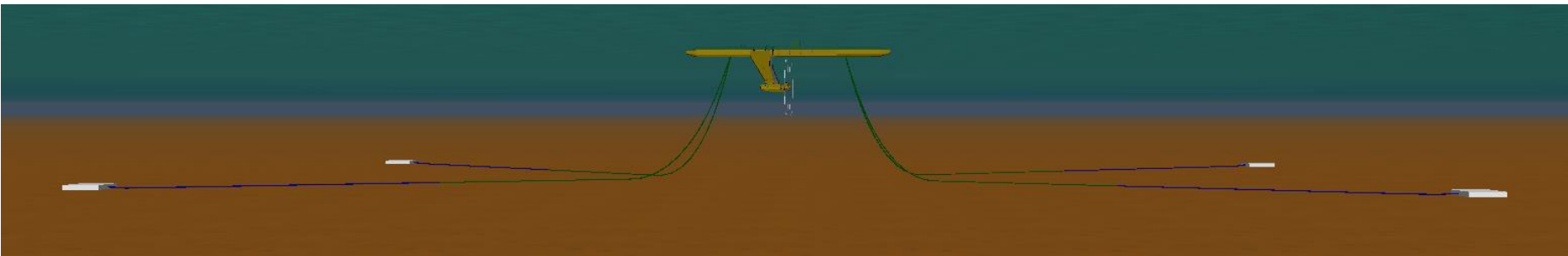

**Figure 6** Orbital O2 mooring system at slack tide (green lines are 95mm Studlink chain, blue lines are 115mm studlink)

#### 4.1.1 Composition of Mooring Lines

Each mooring line will be predominantly composed of studlink mooring chain.

The composition of the mooring lines is given below.

**Table 3**                      **Composition of the mooring lines**

Description	Length (m)	Weight (kg/m)
95mm studlink chain	125m	200
115mm studlink chain	100m	315

It is possible that synthetic rope may be used in the lines as well. If synthetic rope is used it will be in the upper section of the mooring lines and will be jacketed polyester rope approximately 170mm in diameter.

It is possible that up to 8 polymer springs will be added to the mooring lines after the initial installation of the turbine. The purpose of this would be to test whether the springs can reduce peak mooring loads. Each spring will have a length of approximately 4.7m, diameter of 1.2m and weigh approximately 4.2 tonnes. It will be composed of a marine compatible thermoplastic and carbon steel with marine coating of a type standard in the Oil and Gas sector.



**Figure 7.** Mooring spring

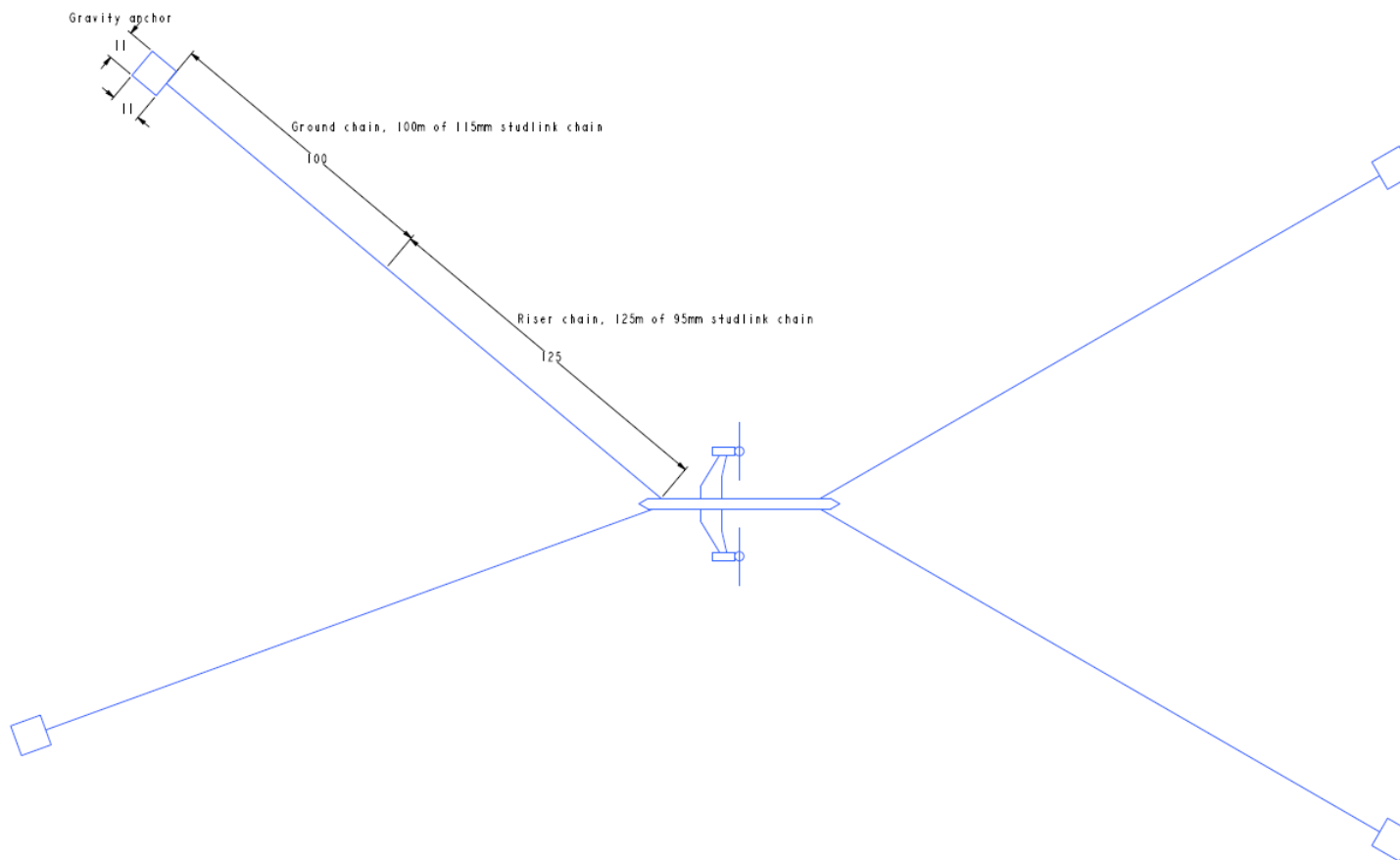

**Figure 8** Schematic showing make up of each mooring line

## 4.2 Anchors

The Orbital O2 will be held by 4 gravity anchors of equal weight. The anchors will be composed of a 'steel basket' which will be filled with ballast. The baskets will be approximately 11m x 11m x 2.5m and will have a weight of approximately 35T.

The ballast will consist of a combination of concrete modules (reused from the SR1-2000 anchor system), scrap steel chain or steel modules.

- Concrete modules would be 5m x 4m x 2m and have a dry weight of 65 T each
- Scrap chain would be approximately 76mm diameter.
- Steel modules would be approximately 5.6m x 5.2m x 2m.

Total weight of the anchors including ballast would be no more than 600T per anchor.

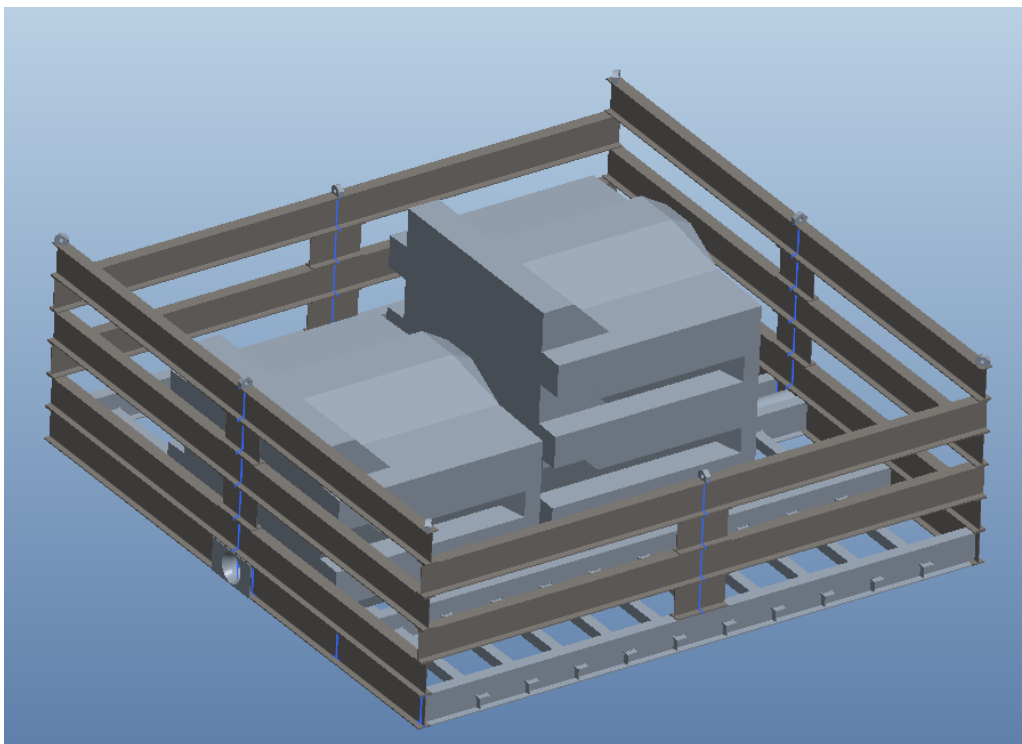

**Figure 9** Anchor basket with ballast

### 4.2.1 Scour Protection

Concrete mattresses will be placed around each anchor to prevent scour. Each mattress will have a weight of up to 10T and size of around 6m x 3m x 0.3m. Up to 8 mattresses will be used per anchor, giving a total of up to 32 mattresses.





**Figure 10. Scour protection concrete mattress**

### **4.3 Mooring Connectors**

The mooring connectors will be type classified and will be configured to meet the specific requirements of the installation. There will be an upstream and downstream connector joining and terminating the catenary mooring system from the upstream and downstream gravity anchors.

A winch system based on the turbine platform will recover the connector from the seabed during the mechanical connection procedure where it will be mechanically connected to a receptacle on the hull. Secondary hydraulic systems will lock the connector in position.

During any removal of the Orbital O2, following disconnection and laydown of the electrical connections, the connections will be disengaged from the hydraulic system and the on-platform winch system will lower the connectors to the seabed. These connector and associated chain will have sufficient on bottom mass to not require additional weight.

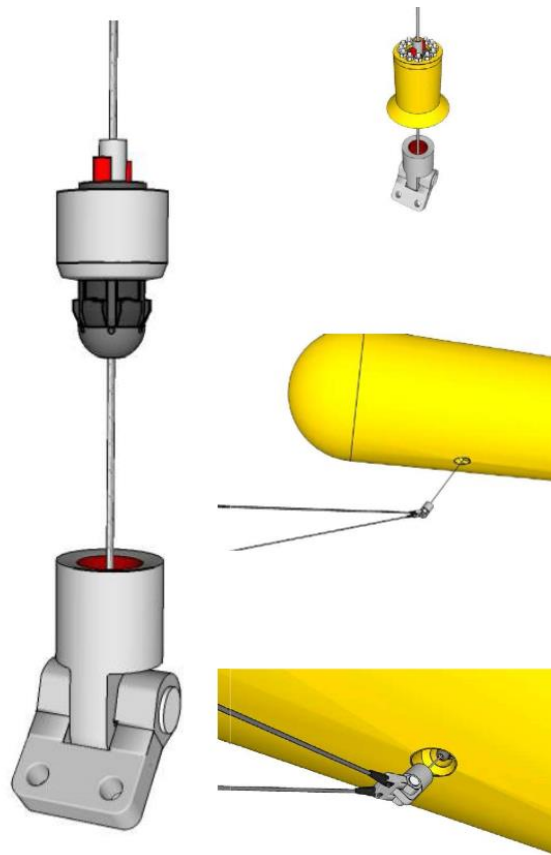

**Figure 11 Orbital O2 mooring connector**

#### **4.3.1 Excursion of Orbital O2 during changes in tidal direction**

As the tide changes direction, the turbine will move in the direction of the tidal current. Some lateral movement (perpendicular to the tidal current) is predicted also. It has been modelled that the Orbital O2 will move by no more than 25 m in any direction.

#### **4.4 Device marking and lighting**

The Orbital O2 will have a marking and lighting schedule as advised by the Northern Lighthouse Board in the navigation risk assessment consultation process.

The device will be yellow in colour/ above the water line and likely to be maroon/brown (antifoul) paint colour below the waterline. The Orbital O2 will be lit by 2 yellow lights synchronised flashing once every three seconds (Fl Y 3s) with a nominal range of 3 nautical miles and mounted a minimum of 3m above the waterline. Additionally, the device will be fitted with a radar reflector at a similar elevation and a navigation aid AIS (Automated Identification System) transmitter as requested by the Northern Lighthouse Board.

#### 4.5 Installation and maintenance vessel

The vast majority of Orbital O2 marine operations will be undertaken using a multi-cat work vessel, see Figure 12 below and a RHIB where necessary. Multi-cat vessels are relatively small but very powerful workboat tugs that typically have a large deck area, high capacity hydraulic cranes and large winches. Further details are provided in Section 5.4.

There is potential that the installation of one anchor may be trialled using a gantry barge.

An Anchor Handling Tug (AHT) style vessel may also be employed to load test the moorings prior to connection of the Orbital O2.



**Figure 12** Multi-cat workboat Green Isle towing SR2000

## 5 Project activities

### 5.1 Summary

It is anticipated that work on site at EMEC could commence in June 2019 at the earliest. A summary of the installation programme is provided in the table below.

**Table 4 Orbital O2 Installation programme**

Activity	Location	Approximate duration	Approximate timescale
Mooring installation	Berth 5	8 weeks	June/July 2019
Dynamic Cable installation	Berth 5	1 week	August 2019
Turbine delivery to Orkney	Outwith EMEC area	5 days	December 2019
Turbine in water assembly	Hatston Pier	10 days	December 2019
Mooring connection trials	Berth 5	1 week	December 2019
Install on moorings	Berth 5	2 days	January 2020
First Grid connection	Berth 5	2 days	January 2020
Commissioning	Berth 5	12 weeks	January – April 2020
Operation	Berth 5	18 years	2020 - 2038
Decommissioning	Berth 5	6 months	2039

### 5.2 Site preparation

Prior to the installation of the Orbital O2 mooring system the Berth 5 site will be surveyed using an ROV and ADCP measurements of the tidal currents at the site will be collected. Grab sampling of the seabed may be undertaken to assess the suitability of the seabed for the anchoring technology.

If deemed necessary seabed friction coefficient trials will be undertaken, which would involve load measured tensioning of a seabed material over the seabed to ascertain the point at which friction is lost and the material drags. This information will feed into anchor design and final mass calculations required per anchor.

Throughout the project Orbital's operations will use a variety of survey systems to gain a baseline and subsequent understanding of the site, this will be a combination of Side Scan Sonar, Multibeam and Magnetometer as well as Drop Down Camera and Remotely Operated Vehicle surveys.

### 5.3 Cable splice

An additional length of cable will be required to form the connection between the EMEC Berth 5 cable end and the Orbital O2 electrical termination. The additional length of cable will be up to 600m long. This cable will be installed via a vessel anchored using a temporary four point anchor mooring spread. The anchors would consist of 4 x 30T chain based gravity anchors connected to mooring buoys. The vessel will be on site to undertake the cable splice for approximately 36 hours.

The vessel will recover the static end of the cable from the seabed and connect a new section of cable using an approved subsea joint. Following splicing operations, the vessel will deploy the new cable over the seabed along with small sections of ballast chain links to increase on-bottom stability at the

tidal site. These links will be connected to the cable via nylon clamps. Following deployment of the cable, the end will be terminated in a suitable recovery system and secured with a 5 tonne gravity mass and surface piercing recovery line and buoy.

There will also be a permanent anchor attached to the cable at the point where it lifts off the seabed to rise through the water column to connect to the turbine. This anchor will consist of an approximately 10T steel structure at the position given in Table 1.



**Figure 13. Orbital Marine Power and HV Contractors offshore on a multi-cat vessel cable jointing or “splicing” operations where static cables are permanently connected to the platform cable which supplies power and communications.**

## **5.4 Mooring system installation**

### **5.4.1 Modular anchor installation**

The Orbital O2 installations will utilise gravity anchors comprised of modular heavy ballast sections installed into single holding structures located on the seabed. Each seabed structure or ‘basket’ will have the required volume to accept the total mass of ballast material in modular format. The ballast material will be comprised of a combination of the existing deposited SR2000 concrete modular blocks, repurposed steel chain and / or steel modules.

The anchor basket will be pre-installed and made ready to accept ballast. A length of chain pre-connected will be deployed along with the anchor basket so that it is recoverable to the surface, this chain will form the first section of the chain based catenary mooring system.

The second section of mooring chain forming the main catenary will connect into the pre-installed first section on the deck of a work vessel on site. The completed mooring line will then be terminated with a mooring connector system which interfaces with the floating turbine.

The anchor and mooring installation will be undertaken using a single standard multi-category (Multi-Cat) work vessel or similar. The work vessel will require a minimum working deck area of nominally 125 m<sup>2</sup> with a minimum deck rating of 6 Tonne per square metre to enable sufficient ballast material to be taken offshore from the onshore holding area.

The work vessel will be fitted with a suitable and capable winch. Nominally the winch requires a lifting capacity of 100T pull on the 1<sup>st</sup> layer and braked to 150T, designed to accept 48mm wire used in conjunction with a bow roller rated at 150T SWL, additional hydraulic guide pins and stoppering system is advantageous. Other winching systems could also be suitable following detailed design and risk assessment.

The vessel must be equipped with a crane capacity working over the vessel bow at 8m reach with 25,000Kg lift. This crane is required to lift equipment, gravity anchors and general lifting operations during mobilisation, construction and installation of anchor systems and mooring components.

The majority of operations associated with anchor and mooring installation will require a single workboat vessel. During certain operations, particularly during moored operations where vessels are not in a position to respond to an incident in a timely manner, an additional vessel such as a RHIB or similar class of vessel will be employed to act as safety vessel and provide crew transfers. Such a vessel will be fit for purpose, coded and insured for operating in the tidal environment for 24 Hr operations.

Installation of anchor baskets, modular ballast and mooring infrastructure will all be subject to weather, tidal stream and sea state assessment on a case by case basis. Such assessment will consider the specific task, along with the specific vessel used. It is anticipated that all marine operations will be undertaken during periods of weakest tidal stream within neap tidal cycles, targeting daylight hours and favourable weather. In consideration of the limitations to working in tidal stream it is expected to amount to a period of maximum 10 working days per month during construction not withstanding weather limitation.

#### **5.4.2 Orbital O2 Tow**

Once construction is complete the device will undergo sea trials close to the construction site prior to being towed to Orkney. The device is likely to be towed with hull and legs assembled, but without nacelles and blades which would be road-transported to Orkney separately. The full machine would be assembled in Orkney at a harbour-side location, most likely Hatston Pier.

Once fully assembled, owing to its 'gull-wing' configuration, it is unlikely to be practical for the Orbital O2 to be berthed at a harbour facility. Instead, it is likely that the Orbital O2 would be temporarily moored at a sheltered bay close to the project site. Orbital Marine Power already holds a marine

license for temporarily mooring of its turbines at Inganess Bay. Should an alternative location be required closer to the site, it would be subject to a separately license application.

A range of vessel class will be able to conventionally tow the Orbital O2 from point A to point B, however, in consideration of close quarters movements from harbours and technical requirements associated with handling lines during pre- installation, a Multi-Cat style vessel is considered the best all-round vessel for these operations. Such a vessel will be certified to an approved classification society and coded to the area of operation and task. The vessel would have a minimum power capacity of achieving a bollard pull off 30 Tonnes through a minimum of 2 independent propulsion systems. The vessel would have a towing capability of 50 T winch with a 90 T brake, compatible with 44mm wire, with 500m of length. There must be an approved method of restraining a tow in addition to physical barriers that prevent the tow wire moving abaft the beam, this may be in the form of towing pins and/ or a gog eye system.

The vessel must consider contingency for towing operations, this may be in the form of a second capable winch and emergency tow system. The towing vessel must have sufficient fuel capacity with contingency for the towing operation, taking due consideration for the effect of tidal stream during towing.



**Figure 14: Multi-functional work vessels such as multi-cats are capable of precise movements of platforms in close-quarters and have capacity to tow turbines alongside owing to low well fendered free-board.**

### 5.4.3 Orbital O2 Platform Installation

The installation of the Orbital O2 has been designed to be safe to personnel yet cost efficient, taking a relatively short period of time using low cost vessels with zero requirement for heavy lift or long periods of calm weather. The Installation operation comprises the following:

1. Towing of turbine and connection to moorings – These works require a vessel that has capacity to carefully move the turbine from the holding location, tow the turbine to the installation site and maintain control of the turbine in tidal stream during connection. This vessel will have the same specification as that required for towing the turbine.

2. Connection operation will take place over a neap tidal cycle (two slack periods) using the winching systems installed on the turbine to recover the catenary based mooring system and latch into the connection points installed on the terminal end of the synthetic risers. Once latched and locked into position the turbine will recover the dynamic riser section of cable for installation using the same winching process.

The cable end will be lifted and any temporary keep weights must be removed before passing over cable end to the turbine structure. Following connection of the turbine mechanically, the towing vessel will remove towing equipment and prepare the cable for installation. The turbine will then recover the cable into the turbine and connect to the electrical grid.

During all the installation activities an additional vessel for safety as well as line running and connecting mooring lines is required. This is expected to be a RHIB vessel selected with due consideration of the task required and area of operation.





**Figure 15: Installation vessel must have capacity for working with 2t buoys in tidal stream during pre-connection operations.**

All operations will be contained within the device test berth area and notified to EMEC, Orkney Islands Council Marine Services (Harbours Department) and other relevant stakeholders through the Notice to Mariners system.

#### **5.4.4 Operational phase programme**

Following an initial commissioning phase of approximately 3 months, it is intended that the Orbital O2 be installed for a long term project of up to 19 years.

#### **5.5 Device monitoring and emergency procedures**

During the commissioning phase, outputs from the Orbital O2 will be monitored in real time by the Orbital engineering team through a 24/7 duty manager system. The SCADA system has the facility to set up user configurable alarms that can be transmitted by email, automated phone call or text message to the dedicated duty managers mobile. All parameters of the system can be monitored through the SCADA system and limits or ranges can be setup and alarms generated if the parameter goes outside this limit or range.

A stationing verification system will allow the device to be monitored with control system alerts to the duty manager. Through the use of a GPS system, this function will observe the movement of the device and provide an alert if the system strays from the predefined operational area.

Beyond the commissioning phase, once the engineering team are assured that all systems are working safely and effectively, the Orbital O2 project will move to automated operation.

## **5.6 Ongoing maintenance**

The Orbital O2 is fundamentally designed for ease of access and inexpensive maintenance. As a floating device, scheduled and unscheduled maintenance operations on electrical, control and hydraulic systems can be carried out onboard the device simply by transferring personnel from a small vessel such as a RIB onto the hull of the Orbital O2. From here personnel can enter the hull and access the majority of equipment. It is envisaged that such regular maintenance could take around once per month.

For more significant maintenance operations or where weather conditions preclude a personnel transfer the Orbital O2 can be disconnected from its mooring and towed to a maintenance location. Once disconnected from its moorings and the rotor legs are retracted, the low transport draught of the turbine allows the use of local shallow bays / pontoon facilities for maintenance. Any such activities at a location outwith the EMEC test site, would be subject to a separate license application.

## **5.7 Decommissioning**

Decommissioning of the mooring system at the EMEC Fall of Warness site is included in the project and will take place in 2039 at the latest. As per the requirements of Section 105 of the Energy Act 2004, Orbital will prepare a draft Decommissioning Programme prior to the commencement of the Orbital O2 project. It is understood that functions under this act have been transferred to Scottish Ministers under the Scotland Act 2016. This document will therefore be circulated for consultation as per the requirements of Marine Scotland and the responses to this consultation will inform the final document.

Prior to the full decommissioning plans being developed the following provides a summary of the main activities:

- A Notice to Mariners will be issued detailing the nature and timing of the decommissioning works;
- The electrical connection for the platform will be unlocked and capped, weighted and returned to the seabed.
- The mooring connections fore and aft of the Orbital O2 platform will be un-locked from the device and returned to the neutral buoyancy position marked with the approved pick-up buoy;
- The Orbital O2 will be towed off-site using a multi-cat work boat and taken to an appropriate harbour or sheltered bay location for temporary mooring.
- Each of the mooring shackles connecting the mooring lines to the mooring connectors will then be released and returned to the seabed with navigation/pick-up buoys attached to enable recovery;
- Each of the anchor cages and ballasts will then be recovered including the mooring lines;
- It is anticipated that in the first instance the anchors components will be returned to Hatston pier for re-use, recycling or disposal;

- Operations will be undertaken at slack tide and therefore this process is likely to take up to 6 months to complete;
- Post decommissioning seabed surveys will be undertaken to ensure that all equipment has been removed from the site;
- All operations will be confined to the EMEC berth 5 area and will be undertaken in safe working conditions of wind and sea state.

## 6 Summary

A summary of the location of the anchors and the deposits on the seabed is provided below.

### 6.1 Location of the works

The project will be located entirely within the EMEC Fall of Warness tidal test site and connected to the grid via EMEC Berth 5. Detailed co-ordinates for each anchor are given below.

**Table 5 Location of Orbital O2 anchors**

Anchor	Co-ordinates Universal Transverse Mercator (UTM)		Latitude (WGS84)	Longitude (WGS84)	Water depth CD (m)
NW	510331	6556296	N 59 8.745	W 02 49.165	45
NE	510491	6556417	N 59 8.810	W 02 48.997	40
SE	510708	6556073	N 59 8.625	W 02 48.770	42
SW	510529	6555983	N 59 8.576	W 02 48.958	45
Centre	510528	6556200	N 59 8.693	W 02 48.959	45
Cable anchor	510538	6556207	N 59 8.697	W 02 48.948	45

### 6.2 Description of the works

Orbital plan to install their Orbital O2 device at the site including associated anchoring and mooring infrastructure as described in detail in the Project Information Document.

### 6.3 Nature and Quantity of all deposits below Mean High Water Springs

#### 6.3.1 Permanent deposits

**Table 6 Permanent anchor and cable details**

Element	Description	Composition	Maximum Total weight
Anchor baskets	4 x Steel 'basket' structure housing ballast @35 T each.	Fabricated steel	140 tonnes
Main anchors	4 x anchors concrete ballast	Concrete	1,120 tonnes
Main anchors	4 x anchors steel ballast	Steel (blocks or scrap chain)	1300 tonnes
Cable anchor structure	To hold cable end in place	Steel	5 tonnes

Element	Description	Composition	Maximum Total weight
Cable anchor ballast	To hold cable end in place	Steel	10 tonnes
Anchor cable ballast	Steel ballast along electrical cable	Steel	10 tonnes
Scour protection	Up to 32 concrete mattresses @ 10 T weight each	Concrete	320 tonnes
Scour protection	Up to 32 concrete mattresses, 0.1 T polypropylene per mattress	Polypropylene	3.2 tonnes
Scour protection	Rock aggregate in nylon scour bags	Aggregate	2 tonnes
Scour protection	Rock aggregate in nylon scour bags	Nylon	0.1 tonnes
Subsea Power cable	Power cable from platform mooring connection spliced to EMEC berth 5 cable, 12 kg per m, (up to 600m length)	Electrical cable	7.2 tonnes
Subsea Power cable	Cable protection (bend stiffener)	Polyethylene	0.4 tonnes
Subsea Power cable	Cable protection (bend stiffener)	Nylon	0.2 tonnes

## Chain and rope

Details of the rope and chain requirements for the permanent mooring system options are given in the table below.

**Table 7 Chain and Rope details**

Component	Weight (kg/m)	Total length required (m)	Total weight (tonnes)
95mm studlink chain	200	500	100
115mm studlink chain	315	400	126
Synthetic ropes	-	140	3.5
Steel wire (optional in lieu of synthetic ropes)	-	140	20

**Table 8. Potential additions to the mooring lines**

Element	Description	Composition	Maximum Total weight
Mooring Damper	A maximum of 4 load reducing Springs per each of the 2 lines for a total of 8 springs (3.25 T steel each)	Steel	26 tonnes

<b>Element</b>	<b>Description</b>	<b>Composition</b>	<b>Maximum Total weight</b>
Mooring Damper	A maximum of 4 load reducing Springs per each of the 2 lines for a total of 8 springs (1 tonne polymer each)	Elastomer polymer (Hytrel)	8 tonnes

### 6.3.2 Temporary Deposits

<b>Element</b>	<b>Description</b>	<b>Composition</b>	<b>Maximum Total weight</b>
Work vessel temporary moorings	4 x 30 T chain clumps	Steel	120 tonnes
Work vessel temporary moorings	4 x 10m ground chain @ 1 tonne per chain	Steel	4 tonnes
Work vessel temporary moorings	4 x 50m steel wires @ 0.25 tonnes each	Steel	1 tonne

All permanent and temporary deposits quantities in the marine license application add a 20% contingency margin to the above weights.

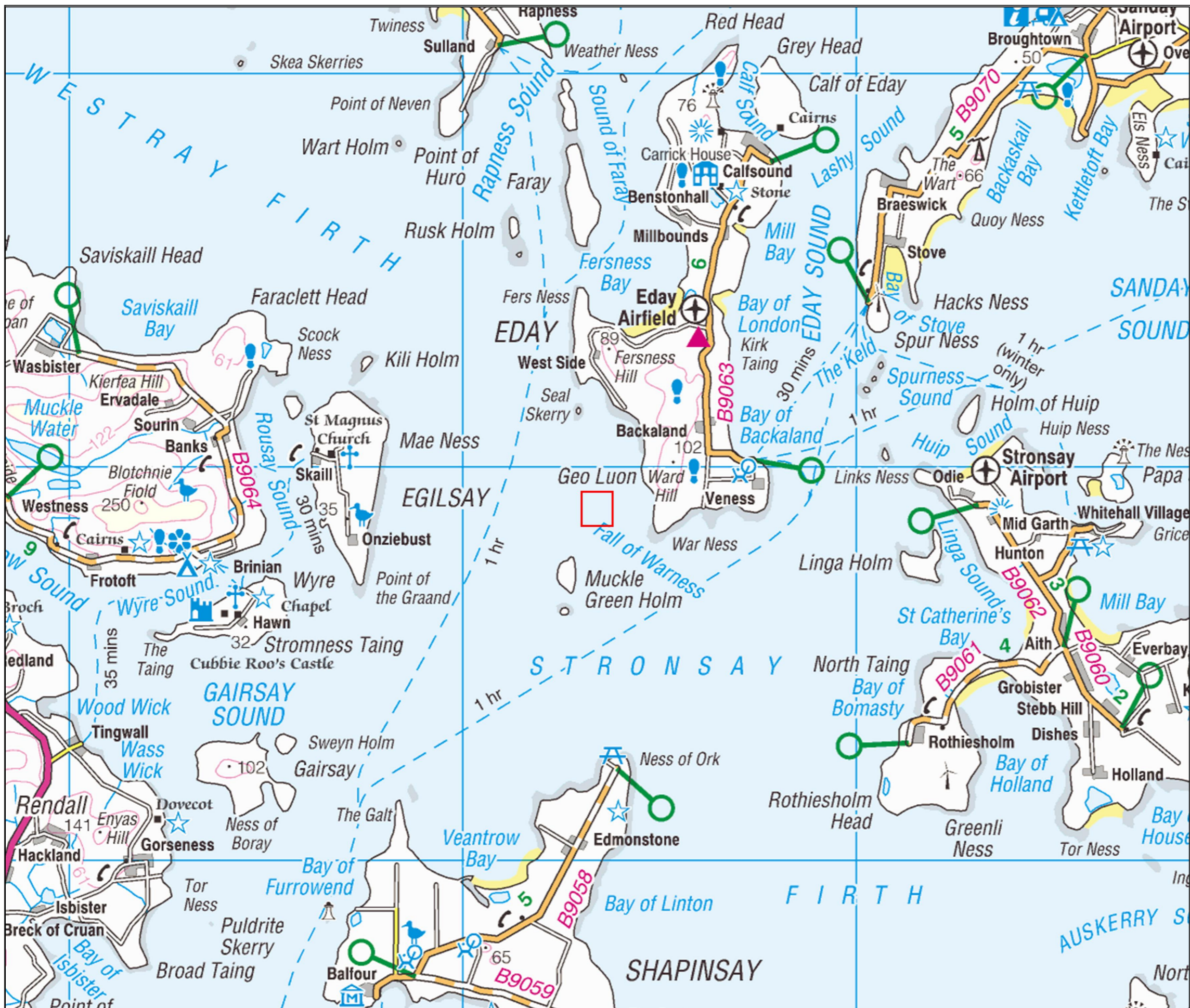

# Orbital O2 Tidal Turbine

## Legend

Installation works maximum extent

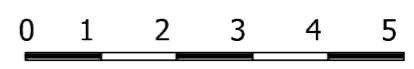

Scale: 1:100,000 @ A3

Projection WGS84 UTM 30N

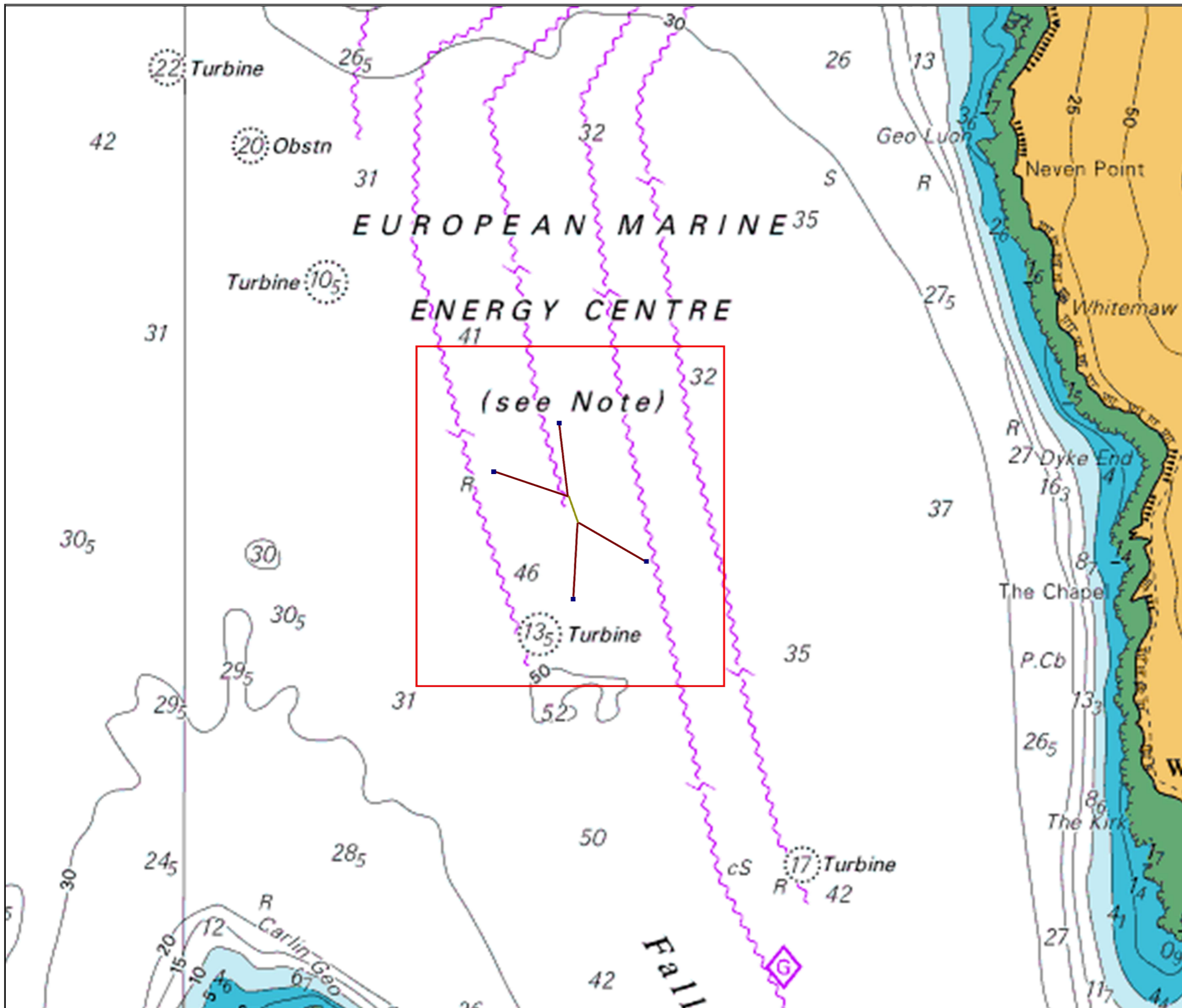

Figure 1. Site Location Plan

Date: 121018 | Drawn by: JM

Drawing No: SR22\_002b





## Orbital O2 Tidal Turbine

### Legend

- Installation works maximum extent
- Orbital O2 turbine
- Mooring line
- Anchor (orientation may vary)

Element	Latitude (WGS84)	Longitude (WGS84)
NW Anchor	N 59 8.745	W 02 49.165
NE Anchor	N 59 8.810	W 02 48.997
SE Anchor	N 59 8.625	W 02 48.770
SW Anchor	N 59 8.576	W 02 48.958
Cable anchor	N 59 8.697	W 02 48.948
NW works extent	N 59 8.917	W 02 49.374
NE works extent	N 59 8.916	W 02 48.558
SE works extent	N 59 8.453	W 02 48.560
SW works extent	N 59 8.454	W 02 49.376

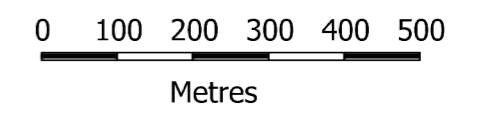

Scale: 1:10,000 @ A3  
 Projection WGS84 UTM 30N

Figure 2. Site layout plan

Date: 121018 | Drawn by: JM  
 Drawing No: SR22\_001b





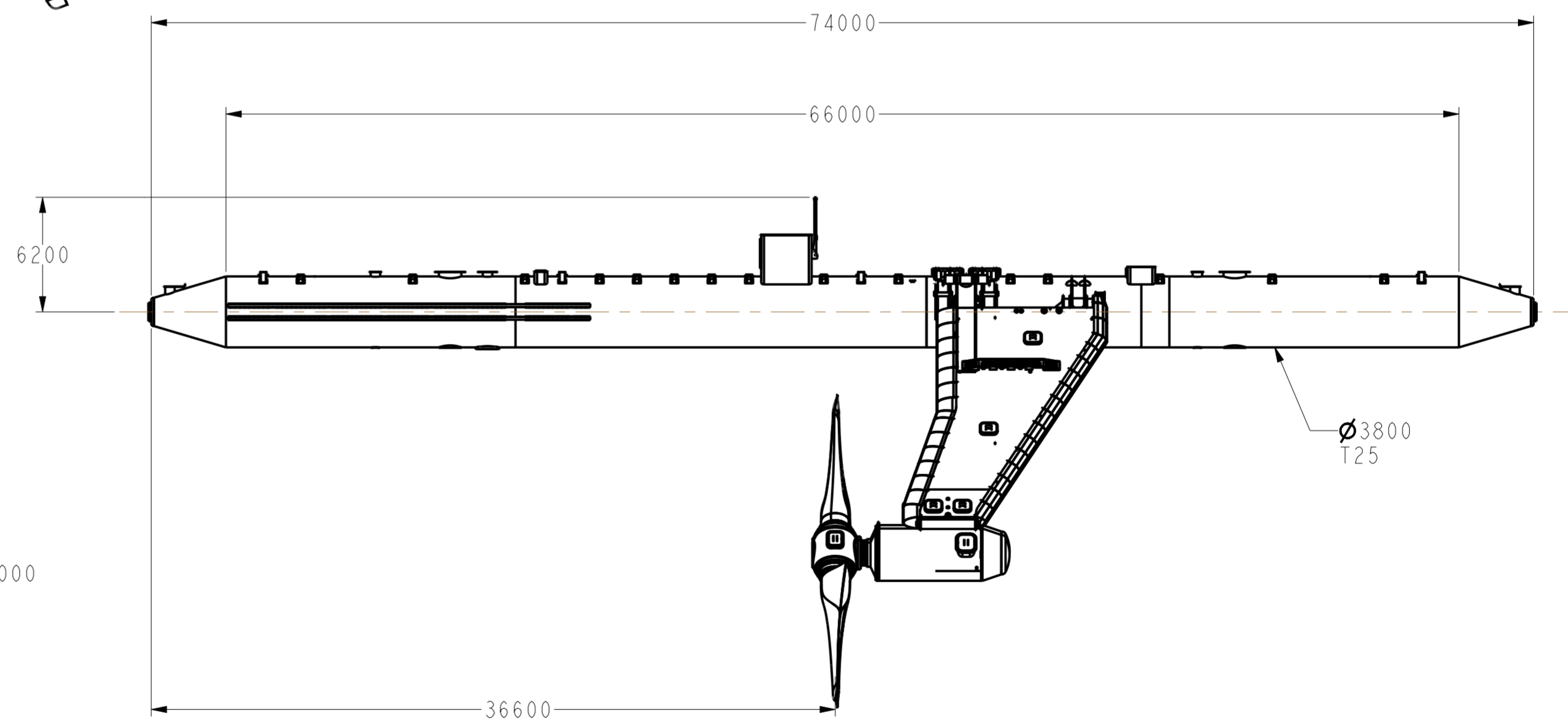
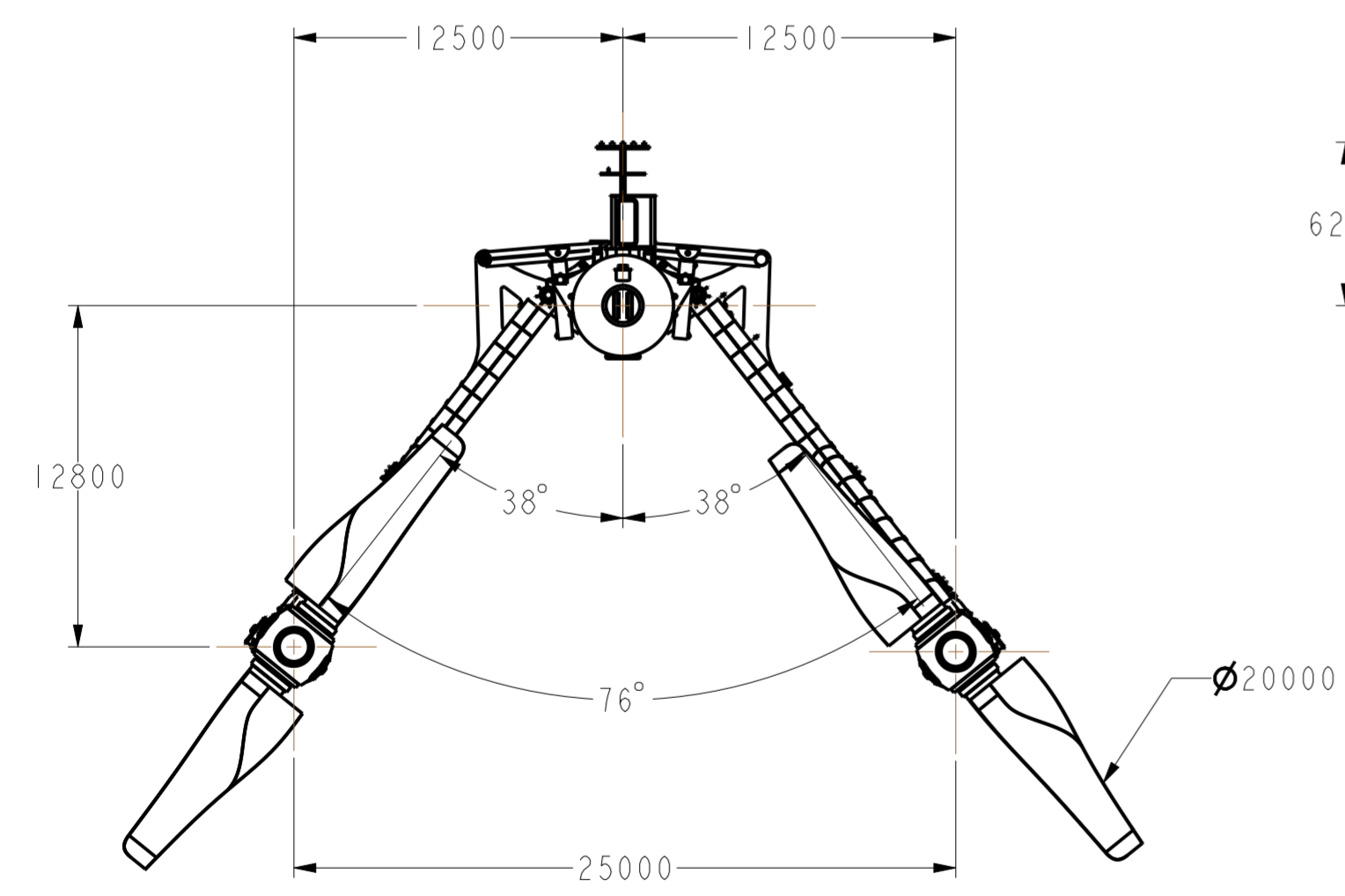
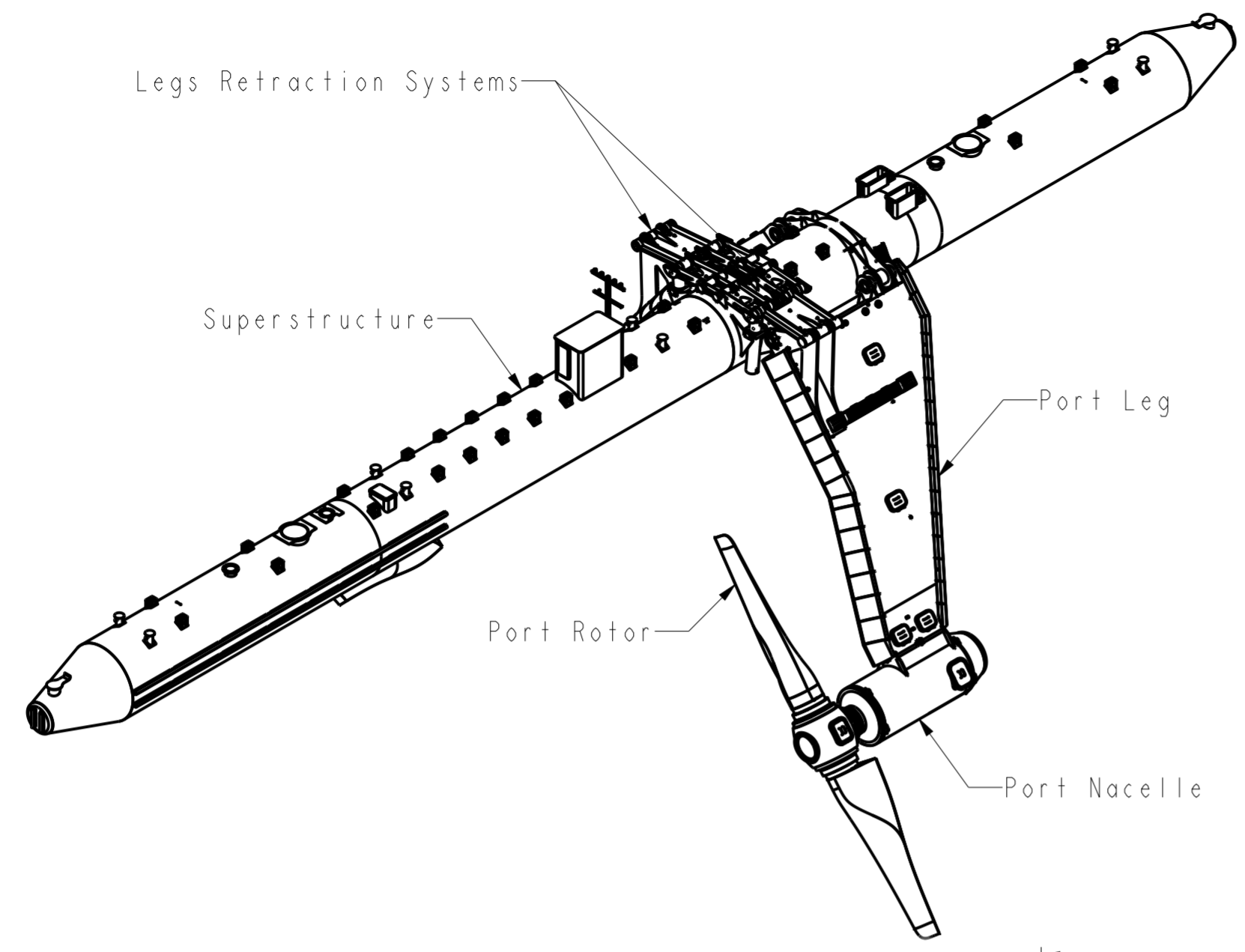

FABRICATION TOLERANCES										WELD PREPARATIONS			PROJECT TITLE		REV.	DATE	REVISION INFO	DRAWN BY	CHK	NOTES																	
REQUIRED TOLERANCE UNLESS STATED ON DRAWING										SYMBOL	ANGLE	GAP	Orbital Marine Power (Orkney) plc		A	18-Jan-17	Information	AB		Sheet Scale: 0.004 Sheet 1 of 2																	
LINEAR DIMENSIONS		TOLERANCE		ANGULAR DIMENSIONS		TOLERANCE		TOLERANCE TYPE					TOLERANCE		DRAWING TITLE		B	27-Jan-17	Information		AB																
0	TO	500	MM	±	1	MM	0	TO	500	MM	±	2	MM	∕	FLATNESS	1	MM	X	30°		1MM	CAD DESIGNATION		C	12-Apr-18	Information	AB										
500		1500		3	500		1500		1		○	ROUNDNESS		SR2-2000																							
1500		3000		5	1500		3000		0.5		—	STRAIGHTNESS		DOCUMENT CODE																	SR2-2000-65						
3000		6000		7	3000		6000		0.3		◎	CONCENTRICITY		MATERIAL																	-						
6000	AND OVER				10		6000	AND OVER			0.1	∕∕	PARRALLELISM	MASS (Kg)							-																
THIRD ANGLE PROJECTION CONVENTION										⊥	PERPENDICULARITY				PRODUCED IN ProE DO NOT CHANGE MANUALLY								COMPONENT														
															NOT TO SCALE UNLESS OTHERWISE STATED								ASSEMBLY														
															SHEET SIZE								-														

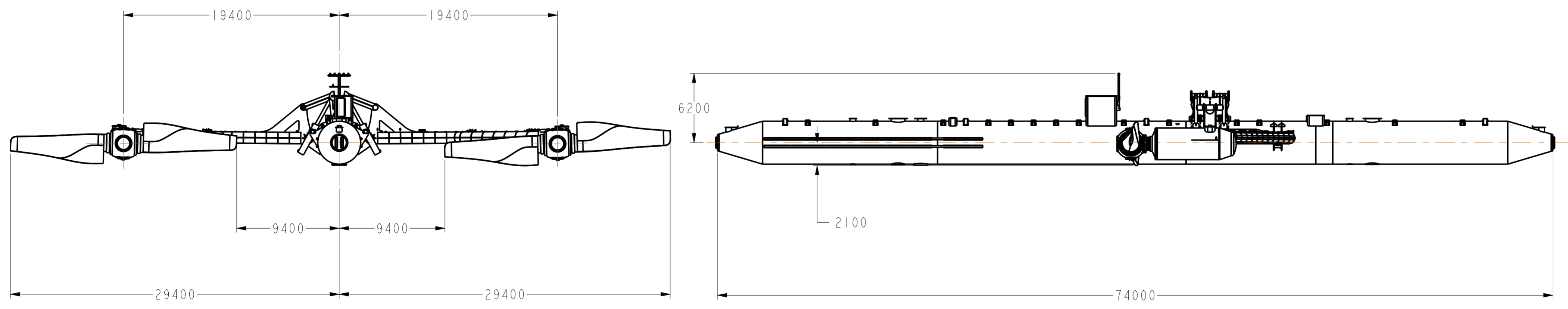
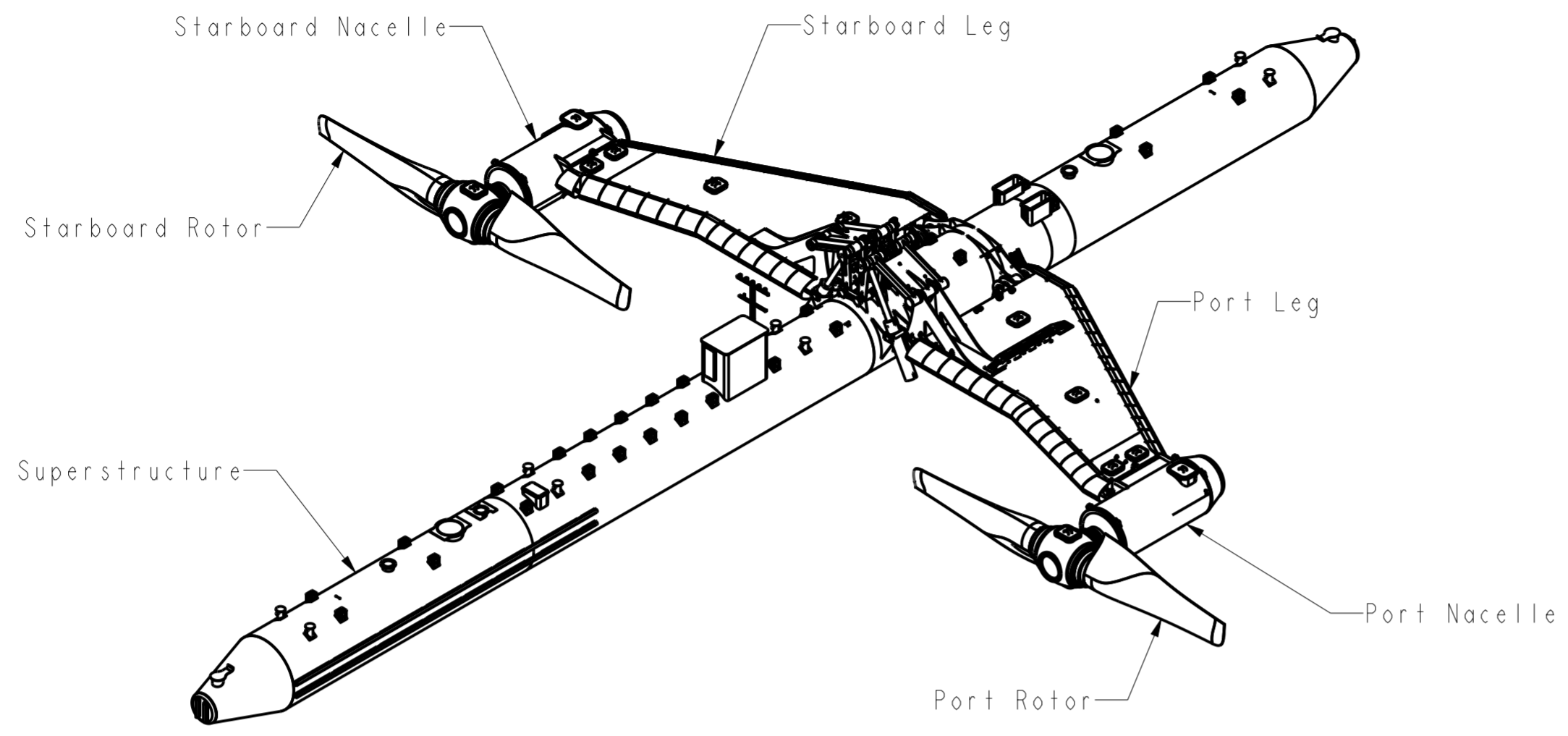

FABRICATION TOLERANCES										WELD PREPARATIONS			PROJECT TITLE Orbital Marine Power (Orkney) plc	REV.	DATE	REVISION INFO	DRAWN BY	CHK	NOTES
REQUIRED TOLERANCE UNLESS STATED ON DRAWING										SYMBOL	ANGLE	GAP							
LINEAR DIMENSIONS		TOLERANCE		ANGULAR DIMENSIONS		TOLERANCE		TOLERANCE TYPE		TOLERANCE		X 30° 1MM K 45° 2MM V 30° 1MM	DOCUMENT CODE SR2-2000-65		PROPRIETARY AND CONFIDENTIAL THE INFORMATION CONTAINED IN THIS DOCUMENT IS THE SOLE PROPERTY OF ORBITAL MARINE POWER LTD. ANY REPRODUCTION IN PART OR AS A WHOLE, WITHOUT THE WRITTEN PERMISSION OF ORBITAL MARINE POWER LTD IS PROHIBITED. PRODUCED IN ProE DO NOT CHANGE MANUALLY NOT TO SCALE UNLESS OTHERWISE STATED	MATERIAL - MASS (Kg) 0.000	COMPONENT - ASSEMBLY -	SHEET SCALE: 0.004 SHEET 2 OF 2	
0	500	1	0	500	2	FLATNESS	100	1 MM IN	MM	SR2-2000-65									
500	1500	3	500	1500	1	ROUNDNESS	300												
1500	3000	5	1500	3000	0.5	STRAIGHTNESS	100												
3000	6000	7	3000	6000	0.3	CONCENTRICITY	100												
6000	AND OVER	10	6000	AND OVER	0.1	PARRALLELISM	100												
THIRD ANGLE PROJECTION CONVENTION						PERPENDICULARITY	100												