

①

\$12 per copy

ADA 112710

2

VOLUME MIXED-GAS DIVING

U S NAVY DIVING MANUAL

NAVSEA 0994-LP-001-9020

REVISION 1

JULY 1981

NAVY DEPARTMENT

WASHINGTON, D.C. 20362



*Original contains color plates. All DTIC reproductions will be in black and white.

DTIC FILE COPY

DTIC

MAR 29 1982

For sale by the Superintendent of Documents, U.S. Government Printing Office
Washington, D.C. 20402
Stock No. 008-046-00092-1

A

SPECIAL NOTE:

A publication is of value only insofar as it is maintained current and informative. The U.S. Navy Diving Manual, Volume 2, Mixed Gas Diving (NAVSEA 0994-LP-001-9020), must reflect all new developments and current procedures in the diving field.

All individuals and activities engaged in diving are authorized and requested to submit constructive criticism and recommendations for improvement of the manual direct to the:

Department of the Navy
Naval Sea Systems Command
Washington, D.C. 20362
Attn: Supervisor of Diving-OOC

The Supervisor of Diving is assigned responsibility for periodic assembly of the field recommendations into proposed numbered changes. These proposed numbered changes will also include information on equipment, techniques, and procedures as they are developed.

The Naval Sea Systems Command is responsible for publication of approved changes to the U.S. Navy Diving Manual.

INSERT LATEST CHANGED PAGES. DESTROY SUPERSEDED PAGES.

LIST OF EFFECTIVE PAGES

NOTE: The portion of the text affected by the changes is indicated by a vertical line in the outer margins of the page.

Dates of issue for original and changed pages are:

ORIGINAL — 0 — September 1973
 CHANGE — 1 — January 1977
 REVISION 1 — July 1981

TOTAL NUMBER OF PAGES IN THIS PUBLICATION IS 240 CONSISTING OF THE FOLLOWING:

Page No.	*Change No.	Page No.	*Change No.
Title	0		
ii	0		
A	0		
B	0		
iii — viii	0		
9-1 — 9-22	0		
10-1 — 10-20	0		
11-1 — 11-26	0		
12-1 — 12-22	0		
13-1 — 13-28	0		
14-1 — 14-16	0		
15-1 — 15-24	0		
16-1 — 16-18	0		
17-1 — 17-16	0		
A-1 — A-6	0		
B-1 — B-2	0		
C-1 — C-14	0		
D-1 — D-8	0		
Index 1-8	0		

Accession or
 Navy Grant
 EICB Fee
 Unannounced
 Investigation
 \$12.00
 DTIC
 Availability Codes
 Full and/or
 Special
 A 24



*Zero in this column indicates an original page

A

U S NAVY DIVING MANUAL

RECORD OF CHANGES

CHANGE NO.	DATE	TITLE OR BRIEF DESCRIPTION	ENTERED BY



TABLE OF CONTENTS

PREFACE

CHAPTER 9—MIXED-GAS DIVING THEORY

HISTORIC DEVELOPMENT OF MIXED-GAS DIVING 9.1	9-1
Oxygen Diving 9.1.1	9-1
Non-Saturation Mixed-Gas Diving 9.1.2	9-3
EQUIPMENT 9.1.2.1	9-4
MIXED-GAS DIVING TABLES 9.1.2.2	9-7
Saturation Diving 9.1.3	9-7
Saturation-Excursion Diving 9.1.4	9-9
MIXED-GAS PHYSICS 9.2	9-10
Boyle's Law 9.2.1	9-10
Charles' Law 9.2.2	9-11
The General Gas Law 9.2.3	9-12
Dalton's Law 9.2.4	9-14
Henry's Law 9.2.5	9-15
MIXED-GAS DIVING PHYSIOLOGY 9.3	9-16
Ventilation, Breathing Resistance and Gas Transport 9.3.1	9-16
Oxygen Toxicity 9.3.2	9-17
CENTRAL NERVOUS SYSTEM (CNS)	
OXYGEN POISONING 9.3.2.1	9-17
PULMONARY OXYGEN POISONING 9.3.2.2	9-19
Use of Oxygen and Other Gases in Decompression 9.3.3	9-20
Body Heat Loss and Temperature Balance 9.3.4	9-20
Distortion of Speech 9.3.5	9-21
Other Physiological Concerns 9.3.6	9-21

CHAPTER 10—OPERATIONS PLANNING

DEFINE OBJECTIVES 10.1	10-1
COLLECT AND ANALYZE DATA 10.2	10-2
ESTABLISH OPERATIONAL TASKS 10.3	10-2
SELECT DIVING TECHNIQUE 10.4	10-2
SELECT AND ASSEMBLE THE DIVING TEAM 10.5	10-12
BRIEF THE DIVING TEAM 10.6	10-12
EXTERNAL EAR PROPHYLAXIS 10.7	10-12
GAS SUPPLY 10.8	
ASR HE-O₂ Supply System 10.8.1	10-12
HYPERBARIC FLAMMABILITY 10.9	10-18
CHAMBER ATMOSPHERE CONTAMINATION 10.10	10-19

CHAPTER 11—MIXED-GAS UNDERWATER BREATHING APPARATUS

PRINCIPLES OF OPERATION 11.1	11-1
Recirculation and CO₂ Removal 11.1.1	11-2
CARBON DIOXIDE SCRUBBER 11.1.1.1	11-2
BREATHING BAGS 11.1.1.2	11-3
RECIRCULATION SYSTEM FAILURE 11.1.1.3	11-3
Gas Addition, Exhaust and Monitoring 11.1.2	11-3
SEMICLOSED-CIRCUIT 11.1.2.1	11-5
CLOSED-CIRCUIT 11.1.2.2	11-9
U. S. NAVY UBA 11.2	11-11
MK 6 MOD 0 MIXED-GAS UBA 11.3	11-12
Breathing Circuit 11.3.1	11-12
Description of Components 11.3.2	11-13
Pre-Dive Preparations 11.3.3	11-15
Diving Procedures 11.3.4	11-16
Post-Dive Maintenance and Troubleshooting 11.3.5	11-17
MK 11 MOD 0 UBA AND ASSOCIATED EQUIPMENT 11.4	11-18
Diver Umbilical 11.4.1	11-18
UBA MK 11 MOD 0 (Backpack) 11.4.2	11-18
M 11 Facemask 11.4.3	11-18
Thermal Protection 11.4.4	11-18
Set-up Kit 11.4.5	11-22
Ancillary Equipment 11.4.6	11-22
MK 15 MOD 0 MIXED-GAS UNDERWATER BREATHING APPARATUS 11.5	11-22
Equipment Case Assembly 11.5.1	11-22
Recirculation System 11.5.2	11-22
SCRUBBER ASSEMBLY 11.5.2.1	11-22
Electronics Assembly 11.5.3	11-22
OXYGEN ANALYSIS AND CONTROL SYSTEM 11.5.3.1	11-22
OXYGEN CONTROL 11.5.3.2	11-23
DISPLAYS 11.5.3.3	11-24
Pneumatics Assembly 11.5.4	11-24
Special Operational Considerations 11.5.5	11-24
CHAPTER 12—SURFACE-SUPPLIED MIXED-GAS DIVING OPERATIONS	
DIVING EQUIPMENT 12.1	12-1
MK 5 Deep-Sea Mixed-Gas (He-O₂) Outfit 12.1.1	12-1

THE HELMET GROUP 12.1.1.1	12-3	Non-Saturation Diving 13.4.3	13-11
THE DIVING DRESS GROUP 12.1.1.2	12-6	Saturation Diving 13.4.4	13-13
THE HOSE GROUP 12.1.1.3	12-6	DEEP DIVING SYSTEM EMERGENCY OPERATIONS 13.5	13-15
MAINTENANCE TOOLS AND SPARES GROUP 12.1.1.4	12-6	General Criteria 13.5.1	13-15
MIXED-GAS SUPPLY 12.2	12-7	DDC Emergencies 13.5.2	13-15
DIVING PROCEDURES 12.3	12-7	FIRE IN THE DDC 13.5.2.1	13-15
MK 5 He-O₂ Diving 12.3.1	12-8	PRESSURE LOSS OR INCREASE IN THE DDC 13.5.2.2	13-15
CANISTER FILLING 12.3.1.1	12-8	OTHER DDC EMERGENCIES 13.5.2.3	13-16
DRESSING THE DIVER 12.3.1.2	12-8	PTC Emergencies 13.5.3	13-16
IN-WATER PROCEDURES 12.3.1.3	12-11	PTC ENTANGLEMENT 12.5.3.1	13-16
POST DIVE PROCEDURES AND MAINTENANCE 12.4	12-12	PTC PRESSURE LOSS AND FLOODING 13.5.3.2	13-17
LIGHTWEIGHT MIXED-GAS DIVING OUTFIT (MK 1) 12.5	12-13	OTHER PTC EMERGENCIES 13.5.3.3	13-17
OPEN BELL 12.6	12-15	DEEP DIVING SYSTEM MK 2 13.6	13-18
ACCESSORY EQUIPMENT FOR MIXED-GAS DIVING 12.7	12-16	Personnel Transfer Capsule 13.6.1	13-18
Hot Water Suit 12.7.1	12-17	GENERAL 13.6.1.1	13-18
Communications 12.7.2	12-18	HULL 13.6.1.2	13-18
HELLE VOICE UNSCRAMBLER 12.7.2.1	12-18	HATCHES 13.6.1.3	13-20
MK 12 SURFACE-SUPPORTED MIXED-GAS DIVING SYSTEM 12.8	12-20	SUPPORT FRAME 13.6.1.4	13-20
Diving Procedures 12.8.1	12-20	ANCHOR 13.6.1.5	13-20
Diving Supervisor's Checklist 12.8.2	12-21	GAS SYSTEM 13.6.1.6	13-20
		ELECTRICAL SYSTEMS 13.6.1.7	13-21
		COMMUNICATIONS (AUDIO AND VISUAL) 13.6.1.8	13-22
CHAPTER 13—DEEP DIVING SYSTEMS		Strength-Power-Communication Cable and Deck Winch 13.6.2	13-22
U. S. NAVY DEEP DIVING SYSTEMS 13.1	13-1	STRENGTH-POWER-COMMUNICATION CABLE (SPCC) 13.6.2.1	13-22
APPLICATIONS OF DEEP DIVING SYSTEMS 13.2	13-2	SPCC DECK WINCH 13.6.2.2	13-22
Observation Mode 13.2.1	13-2	Deck Decompression Chamber 13.6.3	13-23
Non-Saturation Diving 13.2.2	13-2	GENERAL 13.6.3.1	13-23
Saturation Diving 13.2.3	13-2	CHAMBER CONSTRUCTION 13.6.3.2	13-23
Other Uses 13.2.4	13-3	INNER LOCK 13.6.3.3	13-24
MAJOR COMPONENTS OF A DDS 13.3	13-3	OUTER LOCK 13.6.3.4	13-24
Personnel Transfer Capsule 13.3.1	13-3	GAS SYSTEMS 13.6.3.5	13-24
Deck Decompression Chamber 13.3.2	13-4	LIQUID SYSTEMS 13.6.3.6	13-24
Life Support Systems 13.3.3	13-6	COMMUNICATIONS AND INSTRUMENTATION 13.6.3.7	13-24
Control Console 13.3.4	13-6	Main Control Console 13.6.4	13-24
PTC Umbilical 13.3.5	13-7	Life Support System 13.6.5	13-25
PTC Handling Systems 13.3.6	13-8		
Underwater Breathing Apparatus 13.3.7	13-9		
DEEP DIVING SYSTEM OPERATIONS 13.4	13-9	CHAPTER 14—OXYGEN DIVING OPERATIONS	
General Criteria 13.4.1	13-9	OXYGEN DEPTH-TIME LIMITS 14.1	14-1
Observation Diving 13.4.2	13-10	Normal Oxygen Limits 14.1.1	14-1

Limits for Exceptional Operations 14.1.2	14-1	Regulator Failure 14.11.3	14-16
Emergency Limit 14.1.3	14-1	SHIPMENT AND STORAGE 14-12	14-16
CLOSED-CIRCUIT OXYGEN SCUBA 14.2	14-2	CHAPTER 15—MIXED-GAS	
Principles of Operation 14.2.1	14-2	SURFACE-SUPPLIED DECOMPRESSION	
Main Components 14.2.2	14-4	GENERAL INSTRUCTIONS 15.1	15-1
CYLINDER, VALVE, AND REGULATOR		Oxygen Concentration 15.1.1	15-1
14.2.2.1	14-4	Selection of Schedules 15.1.2	15-1
BACKPLATE, COVER, AND CANISTER		Exceptional Exposures 15.1.3	15-1
ASSEMBLY 14.2.2.2	14-4	Repetitive Dives 15.1.4	15-1
VEST, BREATHING BAGS, AND		Decompression Sickness 15.1.5	15-1
MOUTHPIECE ASSEMBLY 14.2.2.3	14-4	HELIUM-OXYGEN SURFACE-SUPPLIED	
WAIST VALVE ASSEMBLY 14.2.2.4	14-4	DECOMPRESSION TABLES 15.2	15-2
Cylinder, Valve, and Regulator 14.2.3	14-4	Oxygen Limits 15.2.1	15-2
Backplate, Cover, and Canister		Inert Gas Partial Pressure 15.2.2	15-2
Assembly 14.2.4	14-5	Use of HE-O ₂ Partial Pressures	
Vest, Breathing Bags, and Mouthpiece		Table 15.2.3	15-4
Assembly 14.2.5	14-6	DECOMPRESSION PROCEDURE 15.3	15-4
Waist Valve 14.2.6	14-8	Operating Procedures for In-water	
HANDLING AND ASSEMBLY 14.3	14-8	Decompression 15.3.1	15-4
Assembly of Components 14.3.1	14-8	OPERATING PROCEDURE FOR	
CHECK COMPONENTS 14.3.1.1	14-8	SURFACE DECOMPRESSION 15.4	15-5
VEST AND BREATHING BAG ASSEMBLY		HE-O₂ DIVING CHART 15.5	15-9
14.3.1.2	14-8	EMERGENCY DECOMPRESSION	
CYLINDER, REGULATOR, AND WAIST		PROCEDURES 15.6	15-9
VALVE ASSEMBLY 14.3.1.3	14-9	Emergency Helium-Oxygen	
FINAL ASSEMBLY 14.3.1.4	14-9	Table 15.6.1	15-9
PREDIVE EQUIPMENT PREPARATION		Emergency Air Table 15.6.2	15-11
14.4	14-9	RULES FOR HE-O₂ SUPPLY & O₂	
Charging the Oxygen Cylinder 14.4.1	14-9	TOXICITY PROBLEMS DURING ASCENT	
Loading the Carbon Dioxide Absorption		15.7	15-12
Canister 14.4.2	14-10	OMITTED DECOMPRESSION IN	
Checking the Inhalation and Exhalation		EMERGENCIES 15.8	15-13
Valves 14.4.3	14-10	VARIATION IN RATE OF ASCENT	
Checking the Apparatus for Oxygen		15.9	15-13
Leakage 14.4.4	14-10	CHAPTER 16—MIXED-GAS	
PREDIVE EQUIPMENT CHECKLIST 14.5	14-11	SCUBA DECOMPRESSION	
PREDIVE APPARATUS INSPECTION 14.6	14-11	MIXED-GAS SCUBA DECOMPRESSION	
DONNING EQUIPMENT 14.7	14-11	TABLES 16.1	16-1
SURFACE CHECKOUT 14.8	14-14	Helium-Oxygen SCUBA	
UNDERWATER PROCEDURES 14.9	14-14	Decompression Table 16.1.1	16-1
POSTDIVE PROCEDURES 14.10	14-14	Helium-Oxygen SCUBA	
Routine Cleaning 14.10.1	14-14	Decompression Table Using	
Lubrication 14.10.2	14-15	Oxygen 16.1.2	16-1
General Inspection 14.10.3	14-15	Helium-Oxygen SCUBA No-Decom-	
TROUBLESHOOTING 14.11	14-15	pression Limits Table 16.1.3	16-5
Loss of Gas from Apparatus 14.11.1	14-15	Helium-Oxygen SCUBA Residual Helium	
Entrance of Water into Apparatus 14.11.2	14-16		

Timetable For Repetitive Dives 16.1.4	16-5
Nitrogen-Oxygen SCUBA Tables 16.1.5	16-7
Nitrogen-Oxygen Repetitive Dive Procedure 16.1.6	16-8
Omitted Decompression in Emergencies—Mixed-Gas SCUBA 16.1.7	16-8
Use of Surface Decompression Tables 16.1.8	16-8
Surface Decompression Tables Not Applicable 16.1.9	16-8
MARK 15 0.7 ATA CONSTANT PARTIAL PRESSURE OXYGEN IN NITROGEN 16.2	16-10
Omitted Decompression in Emergencies 16.2.1	16-10
PPO ₂ Variances 16.2.2	16-11

CHAPTER 17—HELIUM-OXYGEN SATURATION DIVING

SATURATION DDC OR HABITAT DEPTH 17.1	17-1
EMERGENCY GAS MIXTURES 17.2	17-1
TREATMENT GAS MIXTURES 17.3	17-1
UNDERWATER BREATHING APPARATUS OXYGEN PARTIAL PRESSURE 17.4	17-1
FIRE PROTECTION 17.5	17-2
RECORDS 17.6	17-2
DDC, HABITAT AND PTC ATMOSPHERE CONTROL 17.7	17-3
INITIAL COMPRESSION TO 22 FEET 17.8	17-3
LIFE SUPPORT SYSTEM CHECKOUT 17.9	17-4
COMPRESSION TO DEPTH 17.10	17-4
EXCURSION LIMITS 17.11	17-4
STANDARD SATURATION DECOMPRESSION 17.12	17-7
DECOMPRESSION SICKNESS TREATMENT 17.13	17-7
EXTERNAL EAR PROPHYLAXIS 17.14	17-8

APPENDICES—

APPENDIX A—

MARK 6 MOD 0 MIXED-GAS SCUBA Pre-Dive Equipment Preparation Checklist A.1	A-1
Troubleshooting Chart A.2	A-5

APPENDIX B—

ACCIDENT/INCIDENT EQUIPMENT STATUS	B-1
------------------------------------	-----

APPENDIX C—

DIVING GASES—PURITY STANDARDS AND CYLINDER DATA

PURITY STANDARDS AND CYLINDER DATA C.1

Oxygen—Military Specification MIL-0-27210	C-1
Nitrogen—Federal Specification BB-N-411 Series	C-1
Helium—Military Specification MIL-P-27407	C-1
Compressed Air—Federal Specification BB-A1034	C-1

MIXING PROCEDURES C.2

Mixing by Partial Pressure	C-5
Continuous-Flow Mixing	C-8
Mixing by Volume	C-8
Mixing by Weight	C-9

GAS ANALYSIS C.3

SAFE HANDLING RULES FOR COMPRESSED GAS CONTAINERS C.4

APPENDIX D—

SURFACE-SUPPLIED MIXED-GAS DIVING OPERATIONS—PRE-DIVE CHECKLIST

MARK 5 DIVING OUTFIT D.1

Diving Equipment Preparation	D-1
Mixed-Gas Supply Preparation	D-1
Air Supply Activation	D-1
Hose Inspection	D-1
Recompression Chamber Check-Out	D-1
Final Preparations	D-3
Immediately Prior to Start of Diving	D-3

MK 1 DIVING OUTFIT D.2

Diving Equipment Preparation	D-3
Mixed-Gas Supply Preparation	D-4
Air Supply Activation	D-4
Hose Inspection	D-4
Equipment Test With Activated Gas Supply	D-5
Recompression Chamber Check-Out	D-5
Final Preparations	D-5
Immediately Prior to Start of Diving	D-5

MK 12 MIXED-GAS DIVING OUTFIT D.3

Diving Equipment Preparation	D-5
Mixed-Gas Supply Preparation	D-6
Air Supply Activation	D-7
Hose Inspection	D-7
Recompression Chamber Check-Out	D-7
Final Preparations	D-7
Immediately Prior to Start of Diving	D-8

CHAPTER NINE

MIXED-GAS DIVING THEORY

The term, "mixed-gas diving," refers to diving operations conducted using any breathing medium other than air. This medium might consist of nitrogen and oxygen in proportions other than those found in the atmosphere, or it might consist of a mixture of other inert gases with oxygen. The breathing gas might also be 100% oxygen itself, which is not technically a "mixed" gas but which requires similar knowledge and training for safe use. Mixed-gas operations do not exclude the use of air and may be used in some phase of a mixed-gas dive.

Mixed-gas diving is generally a complex undertaking. A mixed-gas operation requires detailed planning, the use of specialized and advanced equipment, and extensive surface support personnel and facilities. Because of the very nature of mixed-gas operations—often conducted at great depth or for extended periods of time—hazards to personnel and to the success of the operation are greatly increased. For these reasons there can be no such thing as a "casual" mixed-gas dive.

The U. S. Navy Diving Manual, Volume One, is a comprehensive introduction to the theory and practice of diving with surface-supplied air, or with SCUBA using compressed air as the breathing medium. Any diver approaching the study of mixed-gas diving must first be qualified in air diving operations, and a thorough familiarity with the contents of Volume One is presupposed in the material presented in Volume Two.

This chapter presents information on the development and employment of mixed-gas diving equipment and techniques, and also serves to orient the diver to important aspects of underwater physics and physiology as they particularly apply to mixed-gas diving. Additionally, planning factors unique to mixed-gas operations are considered.

HISTORIC DEVELOPMENT OF MIXED-GAS DIVING 9.1

Oxygen Diving 9.1.1 Diving equipment which had been developed through the mid-nineteenth century greatly limited a diver's freedom of movement because of the requirement for surface-supplied air. Early attempts to supply self-contained compressed



Figure 9-1 Fleuss Apparatus; the first oxygen recirculating breathing apparatus.

air for use by divers were not successful, due to the limitations of both pumps and containers to package air at sufficiently high pressures.

In 1876, Henry Fleuss began development of an oxygen rebreathing device which freed the diver of dependence upon surface support. The Fleuss device used a watertight rubber face mask connected by breathing tubes with a copper tank of oxygen charged to 450 psi and a breathing bag. The diver would inhale pure oxygen. His exhaled breath would pass into the breathing bag and there be drawn through rope yarn which has been soaked in a solution of caustic potash. This chemical absorbed the carbon dioxide, and allowed the unused portion of oxygen to be re-circulated through the face mask. In the early models of this apparatus, the make-up feed of fresh oxygen was controlled by the diver with a hand valve.

Fleuss successfully tested his apparatus in 1879, first in a tank of water where he remained for about an hour, and then by walking along a creek bed at a depth of eighteen feet. During this dive Fleuss, who had an insatiable curiosity, wondered what might happen if he turned off his oxygen feed. He soon became unconscious and suffered gas embolism as he was hauled to the surface by his tenders. A few weeks

after his recovery, Fleuss made arrangements with Augustus Siebe's diving equipment company to put his re-circulating design in commercial production. Somewhat refined, and with the addition of a demand-regulator to replace the need for hand valving of the oxygen, the Fleuss SCUBA became the direct ancestor of a wide ranging family of respirators, submarine escape devices and combat swimmer breathing units.

Combat swimmer breathing units were widely used in World War II, particularly by the British, Italians and Japanese. The swimmers used various modes of attack--some rode diver-guided "chariot" torpedos, and some were carried to the scene of action in midget submarines from which they placed explosive charges under the hulls of enemy ships. Several notable successes were achieved, including the sinking of several battleships, cruisers, and a number of merchant ships.

In 1936, the Italian Navy tested a chariot torpedo system in which the driver-divers used a descendant of the Fleuss SCUBA. This was the "Davis Lung" designed originally as a submarine escape device, and later manufactured in Italy under a license from the English patent holders.

The British began their chariot program in 1942 using the Davis Lung and also exposure suits. Experience soon brought improvements. Swimmers using the MK I Chariot Dress quickly discovered that the steel oxygen bottles adversely affected the compass of the chariot torpedo. Aluminum bottles were not available as an item of supply in England, but German aircraft used aluminum oxygen cylinders. The aircraft cylinders were almost the same size as those aboard the MK I and were easily salvaged in sufficient numbers from downed enemy bombers to correct the problem.

Other changes, through the MK II and MK III dress, involved improvements in valving, faceplate design and arrangement of components. After the war, the MK III became the standard Royal Navy Shallow Water Diving Dress. The MK IV dress, used toward the end of the war, had one major difference from the MK III. The MK IV could be supplied with oxygen from a self-contained bottle, or from a larger cylinder carried in the chariot. This gave the swimmer greater

endurance yet preserved independent freedom of movement away from the chariot torpedo.



Figure 9-2 The original Davis Submerged Escape Apparatus consisted of a breathing bag, relief valve, CO₂ absorbent canister, emergency O₂ capsule, main O₂ cylinder and valve, non-return valve and flexible tube for charging the breathing bag and a tube leading to the mouthpiece.

U. S. combat swimmers in World War II were of two different groups. Naval beach reconnaissance units did not normally use any breathing device, although several models existed. Other groups of U. S. operational swimmers, under the Office of Strategic Services, developed and applied advanced methods for true self-contained diver-submersible operations. They employed a rebreather invented by Dr. C. J. Lambertsen, the Lambertsen Amphibious Respiratory Unit (LARU). The LARU was a closed-circuit oxygen SCUBA for use in clandestine operations where a complete absence of exhaust bubbles was necessary. The standard unit now in use by USN combat swimmers is the Emerson-Lambertsen oxygen rebreather derived from the WW II LARU. However, for most work, open or semiclosed units are usually preferred because of greater depth capabilities and the decreased possibility of oxygen poisoning.

The problem of oxygen toxicity was unknown to Fleuss and was apparently not encountered in early

shallow water experiments with his apparatus. The danger of oxygen poisoning had actually been discovered prior to 1878 by Paul Bert (the same physiologist who first proposed controlled decompression as a solution to the problem of the bends). In experiments with laboratory animals, Bert demonstrated that breathing oxygen under pressure could lead to convulsions and death. In 1899, another researcher found that breathing oxygen over prolonged periods of time, even at pressures not sufficient to cause convulsions, could lead to serious lung irritation.

The results of these experiments were not widely nor quickly known, and for many years divers were not aware of the dangers of oxygen poisoning. In fact, not until large numbers of combat swimmers were being trained in the early years of World War II did the true seriousness of the problem become apparent. After a number of oxygen-poisoning accidents, the British established an operational depth limit of 33 feet. In recent years, this has been reduced to a working-depth of 25 feet. The subject of oxygen toxicity is discussed in more detail in Section 9.3.2.

Non-Saturation Mixed-Gas Diving 9.1.2. The practical limit for air diving operations was estab-



Figure 9-3 Lambertsen Amphibious Respiratory Unit (LARU).



Figure 9-4 Emerson-Lambertsen Oxygen Rebreather.

lished in 1915 when the USS F-4 was salvaged from 304 feet. The Navy divers were able to work at that depth—but just barely. The decompression requirement, combined with the effects of nitrogen narcosis, limited bottom time for each dive to about 10 minutes.

A few years later, a prolific inventor named Elihu Thomson theorized that helium might be an appropriate substitute for nitrogen in a diver's breathing supply, and he estimated at least a 50% gain in working depth could be achieved by the use of helium. In 1919, he suggested that the U. S. Bureau of Mines investigate this possibility. Thomson directed his suggestion at the Bureau of Mines, rather than the Navy Department, since the Bureau held a virtual world monopoly on the marketing and distribution of helium.

In 1924, the Bureau of Mines and the Navy joined to sponsor a series of experiments in the use of helium-oxygen mixtures. The initial work was done at the Bureau of Mines Experimental Station in Pittsburgh, Pennsylvania. In 1927 the Navy shifted the operations of its own Experimental Diving Unit (EDU) from Pittsburgh to Washington, D. C. where the work continued.

The first tests showed no detrimental effects on animals or humans from breathing a helium-oxygen mixture. The principal physiological effects noted by all divers when using helium-oxygen were the increased sensation of cold caused by the high thermal conductivity of helium and the "Donald Duck" effect on human speech that resulted from the acoustic properties of the gas.

The depth advantage to be gained from the use of helium was soon well established. In 1937, at the EDU, a diver wearing deep-sea diving dress with a helium-oxygen breathing supply was compressed to a simulated depth of 500 feet in a chamber. He was not told the depth, and when asked to make his own estimate he reported that it felt like 100 feet. During decompression, at the 300 foot mark, his breathing mixture was switched to air, and he was troubled im-

mediately by nitrogen narcosis. The first practical test of helium-oxygen came in 1939, when the submarine USS SQUALUS was salvaged from a depth of 243 feet.

In 1940 Lambertsen proposed that mixtures of nitrogen or helium with oxygen be used in SCUBA to limit both oxygen toxicity and the problem of bends. This proposal led to his development of the mixed-gas rebreathing apparatus from which the current Navy Mk 6 was derived after WW II.

Through all of this period, the U. S. Navy was the acknowledged world leader in helium-oxygen diving technology. However, Navy divers were not the only divers working with mixed gases or with helium. In 1937, a civilian engineer named Max Gene Nohl reached 420 feet in Lake Michigan while breathing helium-oxygen and using a suit of his own design. In 1946, civilian diver Jack Browne (who designed the lightweight diving mask which bears his name) made a simulated helium-oxygen dive of 550 feet. Later, in 1948, a British Navy diver set an open-sea record of 540 feet while using war-surplus helium originally provided by the United States.

In other countries, where the availability of helium was more restricted, divers experimented with mixtures of other gases. The most notable example is that of the Swedish engineer Arne Zetterstrom who worked with hydrogen-oxygen mixtures. The explosive nature of such mixtures was well known, but it was also known that hydrogen would not explode when used in a mixture of 4% oxygen. At the surface this percentage of oxygen would not be sufficient to sustain life. However, at 100 feet, the oxygen partial pressure would be the equivalent of 16% oxygen at the surface. Zetterstrom devised a simple method for making the transition from air to hydrogen-oxygen without exceeding the 4% oxygen limit. At the 100 foot level, he replaced his breathing air with a mixture of 96% nitrogen and 4% oxygen, and then replaced that mixture with hydrogen-oxygen in the same proportions. In 1945, after some successful test dives to 363 feet, Zetterstrom reached 528 feet. Unfortunately, a misunderstanding on the part of his topside support personnel resulted in a too-rapid return to the surface. Zetterstrom did not have time to enrich his breathing mixture or to adequately decompress. He



Figure 9-5 Recovery of the SQUALUS; the first U.S.N. Operation using He-O₂.

was killed by the effects of the ascent. Experimentation with hydrogen as a component of breathing gas has continued sporadically, but without significant results.

A young diving enthusiast from Switzerland, Hannes Keller, was later to study Zetterstrom's work (among others) and to evolve his own breathing mixture which, depending upon the depth of the dive, involved changing proportions of nine different gases. In 1962 (with partial support from the U. S. Navy) he reached an open sea depth of more than 1000 feet off the California coast. This exceptional dive was also marked with tragedy: Keller's companion was killed by decompression sickness.

In recent years, to match basic operational requirements and capabilities, the U. S. Navy has generally divided mixed-gas diving into two basic categories: non-saturation diving without a pressurized bell to a maximum depth of 300 feet and saturation diving for deeper depth or extended bottom-time missions. The 300 foot limit is not primarily based upon equipment or diver limitations, but rather upon the basic assumption that any Navy diving mission at greater depth will necessarily be a long-term operation. Examples of such missions include submarine rescue and salvage, sea-bed implantments and construction, and scientific testing and observation. These types of operations are characterized by the need for extensive bottom time and, consequently, are more efficiently conducted using saturation techniques.

Two major U. S. Navy contributions to mixed-gas diving have been the development of suitable equipment and the development of standard mixed-gas diving decompression tables.

EQUIPMENT 9.1.2.1 The Navy helium-oxygen helmet has been the standard rig for most mixed-gas diving, and only in the past few years has the MK 12 SSDS been designed which will eventually replace

this unit. The helium-oxygen (He-O₂) helmet is essentially a Mk 5 deep-sea helmet which has been modified by the addition of a system for conserving the gas supply by recirculating the breathing mixture through a carbon dioxide removal device. Because of this feature, the volume of gas required is about one-fifth of that which would be required in a comparable dive in an open-circuit mode. However, the MK 5 helmet weighs more than 100 pounds and imposes an awkward burden on the diver.

There are several newer types of mixed-gas equipment for both surface-supplied and SCUBA operations. These not only increase diver efficiency, but also widen the range of operations in which the diver may function successfully. Specific equipment includes

— **MK 1 MOD 0 MASK**—provides diver life support and communications for working dives to 130 feet using air as the breathing medium; to 190 feet using air as the breathing medium with the additional support of an open diving bell; and to 300 feet using helium-oxygen breathing gas mixtures as the breathing medium with the additional support of an open diving bell. The equipment is issued as a light-weight diving outfit which includes sufficient equipment to support a diving operation employing two working divers and a standby diver. The MK 1 MOD 0 MASK incorporates a mask featuring a demand open-circuit breathing arrangement. The demand breathing arrangement starts to furnish air to its user at the beginning of his inhalation, matches the varying flow requirements of his inhalation breath pattern, and stops flow at the end of his inhalation. The user's exhalation is passed out of the mask into the surrounding water with minimum resistance. The mask has a limited rigid volume and no compliance or storage capability. The mask incorporates a "defogging" feature in the form of a manually adjustable "steady" flow that is blown into the mask and across the interior surface of the faceplate. In limited manner, this air flow can be used for breathing in the event of malfunction of the primary demand breathing arrangement.

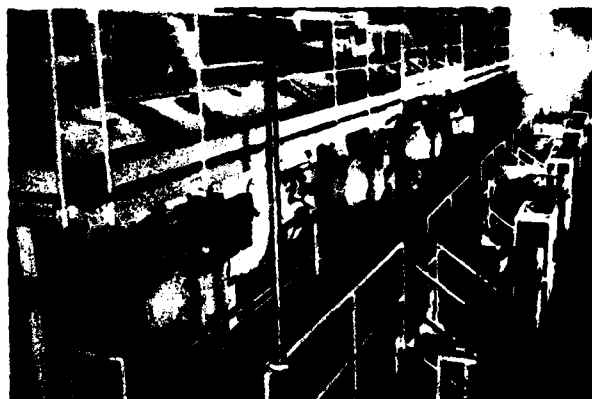

Figure 9-6 EDU's Ocean Simulation Facility at Panama City, Fl.



Figure 9-7 MK 12 and MK 5

—**MK 1 MOD S MASK**—provides diver life support and communications for working saturation excursion dives from a PTC to 1000 feet using He-O₂ as the breathing medium. It is similar in all respects to the MK 1 MOD 0 Mask except that the side block ports have been enlarged to provide less restriction to flow of the denser gas at deep depths.

—**MK 6**—a semiclosed mixed-gas SCUBA which was standard U.S. Navy combat swimmer apparatus. It has a maximum depth capability of 200 feet and an endurance time of 30 minutes to 3 hours depending upon water temperature and diver activity. The breathing mixture may be either helium-oxygen or nitrogen-oxygen, but the latter is most frequently used for reasons of economy and diver comfort. However, the nitrogen-oxygen mixture is not compressed air, and the percentage of oxygen in the mixture must be greater than that of air to avoid hypoxia.

—**MK 11**—a semiclosed SCUBA designed for use in conjunction with personnel transfer capsules for saturation diving. The diver is connected to the PTC by a life-support umbilical through which breathing gas, heat and communications are provided.

—**MK 12**—Surface Supported Diving System (SSDS) is unique in that it is capable of diving with air or mixed gas as the breathing medium in either the open-circuit or semi-closed circuit configuration utilizing the same basic helmet. The recirculator is used as a modular, add-on component for mixed gas operations.

—**MK 14**—Closed Circuit Saturation Diving System (CCSDS) is designed for saturation diving from a personnel transfer capsule (PTC), such as the MK 2 Deep Dive System. The system is closed-circuit in that it takes the diver's supply gas from the PTC atmosphere, pumps it to him through an umbilical hose, and returns his exhaust gas to the PTC through a return umbilical hose. To perform this task, supply and return pumps are installed on the PTC. Also, an exhaust regulator is required at the diver's helmet to maintain the internal hel-



Figure 9-8 MK 12 hard-hat.

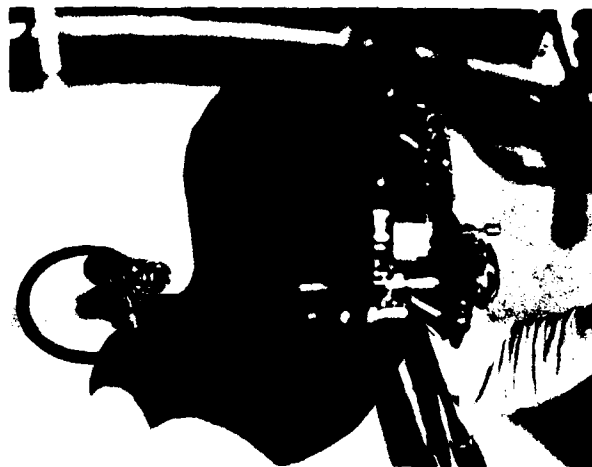

Figure 9-9 U. S. Navy diver wearing a Diver's Mask USN MK 1.

met pressure at essentially ambient seawater pressure. The normal atmosphere conditioning system in the PTC removes the carbon dioxide and maintains the proper oxygen level. The obvious advantage of the MK 14 is the potential for a tremendous savings in helium gas during extended deep dive operations. The MK 14 has the advantage over other closed and semi-closed underwater breathing apparatus in its basic simplicity.

The system consists of four major subsystems: the pump package, PTC control console, umbilical, and the diver-worn equipment. The gas flow path of the MK 14 CCSDS begins with the gas flowing from the PTC to the supply pump where it is boosted in pressure and pushed through a filter in the PTC. It then flows through the umbilical to the diver where it is heated. The warmed gas enters the helmet through a supply valve and muffler/diffuser, and leaves through a safety exhaust valve and exhaust regulator. The exhaust regulator functions as a back-pressure regulator, maintaining a relatively fixed positive pressure in the helmet, with the suction pumps maintaining a suction of between 15 and 75 psig to the downstream side of the regulator.

The safety exhaust valve (SEV) is located on the exhaust side of the helmet and protects the diver from a squeeze that could result from an exhaust regulator failure. In the event of an underpressure in the helmet of approximately 50 cm of water, the SEV closes, blocking the helmet exhaust gas flow path. After leaving the exhaust regulator, the gas is pulled through the return side of the umbilical to the PTC where it passes through a water separator and then to a volume tank. The return pump then pumps it into the pump package housing where it returns to the PTC via an equalizing line.

The System Operational Parameters are:

PTC operating depth	200 to 1000 feet (61-305 m)
Operating temperature	Down to 35° F (1.7 C)
Diver Depth excursion	100 feet below the PTC to 33 feet above (30-10 m)
Number of divers out of PTC	2
Umbilical length	250 feet (76 m)
Diver's respiratory minute volume	75 litres per minute

MIXED-GAS DIVING THEORY

—**MK 15**—a closed circuit breathing apparatus designed for use by the Navy Special Warfare Divers (UDT/SEAL). The MK 15 UBA has a depth limit of 150 FSW and CO₂ absorbent canister duration of 6 hrs at 70°F and 2 hrs 40 min at 40°F. The unit automatically maintains the diver's partial pressure of O₂ at 0.70 ATA by addition of gas from the pure O₂ containing sphere. The other gas sphere contains air diluent. The MK 15 may be used with a full face mask (FFM) to provide diver communications. By providing the diver with an underwater decompression computer (UDC), he may conduct multiple excursion dives to various depths.

—**EMERSON**—a closed circuit pure O₂ SCUBA designed for use when surface bubbles must be kept to a minimum. The normal working limit for the Emerson UBA is 25 FSW for 75 minutes with a maximum emergency limit of 40 FSW for 10 minutes. The depth/time limits are for the prevention of oxygen toxicity.

MIXED-GAS DIVING TABLES 9.1.2.2. Mixed-gas diving tables were originally developed by the Navy and have been regularly up-dated as a result of experimentation and experience. Because the process of up-dating is continuous, divers preparing for mixed-gas operations must verify that the latest edition of the diving tables is on hand. Those tables are:

- Oxygen Depth Time Limits
- Helium-Oxygen Surface Supplied Decompression Tables
- Helium-Oxygen SCUBA Decompression Table
- Nitrogen-Oxygen SCUBA Table
- Unlimited Duration Excursion Tables and Procedures for Saturation Diving
- Standard Saturation Decompression Table
- Underwater Decompression Computer Tables, 0.70 ATA Constant Oxygen Partial Pressure in Nitrogen

Saturation Diving 9.1.3 True scientific impetus was first given to the saturation concept in 1957 when a Navy diving medical officer, George F. Bond, theorized that the tissues of the body would eventually become saturated with inert gas if exposure time was

long enough. Once a diver was saturated, further extension of bottom time would impose no additional decompression time requirement. Captain Bond (then a Commander, and Director of the Submarine Medical Center at New London, Connecticut) supervised a series of experiments, first with animals and then with humans, that proved the theory.

The first practical open-sea demonstrations were undertaken in 1962 with the "Man-in-Sea I" program of E. A. Link (one man breathing helium-oxygen at 200 feet for 24 hours), and "Conshelf One" of Captain Jacques-Yves Cousteau (six men breathing nitrogen-oxygen at 35 feet for 7 days). These pioneers extended both depth and duration during 1964. In that year Link and Lambertsen conducted a two-day exposure of two men at 430 feet, and Cousteau's "Conshelf Two" experiment maintained a group of seven men for 30 days at 36 and 90 feet with excursion dives to much greater depths.



Figure 9-10 E. A. Link's "Man-In-The-Sea" Program.

The best-known U. S. Navy experimental effort in saturation diving has been the SEALAB program. SEALAB I (1964), under the direction of Captain Bond, kept four men underwater for a total of 11 days at an average depth of 193 feet. SEALAB II, a year later, put three teams of 10 men each in a habitat at 205 feet. Each team spent 15 days at depth, and one man remained for 30 days. Later experiments have taken divers to 38 feet for 2 months (TEKTITE 1, 1969—conducted under the joint sponsorship of the USN, Dept. of Interior, and NASA) and 520 feet for 5 days (1970).

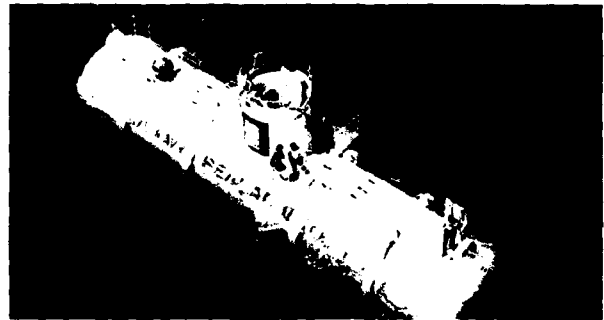

Figure 9-11 U.S. Navy SEALAB habitat.

Saturation diving has been conducted with any of several breathing media—ranging from air (in shallow water operations) to helium-oxygen in a dry chamber test to 2,000 feet.

Two basic life support chamber concepts of saturation diving technique have evolved. In one, the divers actually live underwater for the duration of the dive and are supported in a large submerged habitat. The habitat contains appropriate systems for diver safety and comfort and is designed to operate in pressure balance at depth. The habitat, a pressure chamber, requires that some arrangement be made for appropriate decompression at the end of the operation. In the other basic saturation technique, the divers are regularly cycled in a personnel transfer capsule (PTC) between the underwater work site and a surface chamber, where they are maintained in a saturated condition by life support apparatus maintained by surface personnel.

Using compatible equipment, several deep diving systems (DDS) have evolved in recent years which have been used for both saturation and short-term diving. The principal advantage of such a diving system in non-saturation diving is to eliminate the need for long periods of in-water decompression, thereby increasing diver comfort and safety. With the support of a diving system, the working diver is never far from a dry refuge. The standby diver can also be on the scene at all times, monitoring the progress of the work from the capsule and ready to provide assistance when needed.

For the Navy, deep diving systems (DDS) were suited to the requirement of fleet diving. They have been

designed for transport by air or sea and as permanent installations aboard specially configured ships. A DDS provides wide margins of safety, flexibility and economy in operations.

The portable DDS MK I supported two 2-man teams through a 14-day mission by alternating the teams between the surface chamber and the work site. The DDS MK 2, a larger system designed particularly for long-term saturation diving, will support two 4-man teams for an extended mission profile. The MK 2 system is installed as part of the basic equipment of the ASR-21 class of submarine rescue ships. The MK 1 MOD S diver's mask and MK 11 apparatus are employed from PTC's to provide the diver's breathing medium and communications.

In June 1975, successful deployment of the DDS MK I MOD 0 to a depth of 1148 FSW demonstrated the Navy's capability to conduct open sea saturation diving operations. Research and development continues to extend this limit.

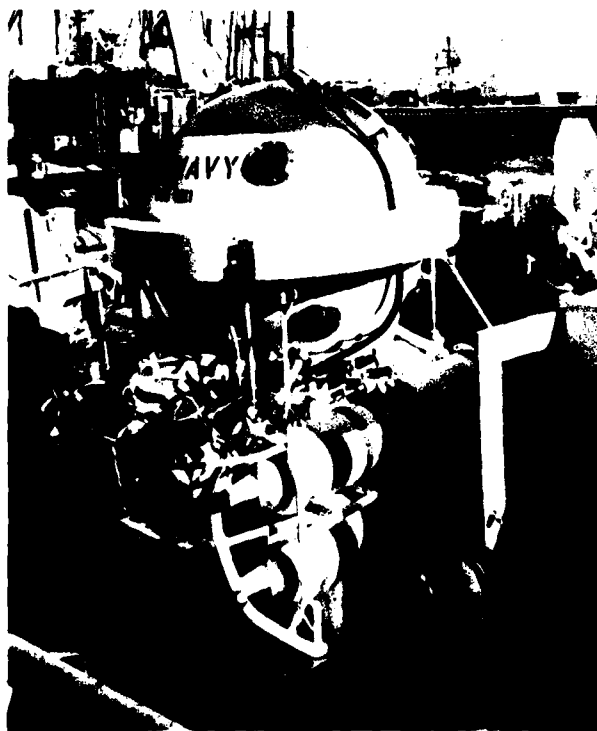

Figure 9-12 Deep Diving System MK I.

The MK 1 MOD 0 has been retired from service use and the DDS MK 2 MOD 0 and MK 2 MOD 1 are the Navy's only saturation diving systems.

Saturation-Excursion Diving 9.1.4 Many diving operations require that work be accomplished at several different levels in the water column or at separate points on an irregular bottom. A saturated diver working out of a habitat or capsule at mid-depth can move to a lower depth for reasonable periods of time and return to the saturation depth without difficulty. This possibility was first demonstrated in Cousteau's "Conshelf Two" (1969), when the divers established an underwater base camp at 31 feet with a deeper chamber set at 87 feet. Divers at the base camp (breathing air with an oxygen partial pressure of 302 mmHg) made excursion dives to 165 feet. Divers in the deeper habitat breathed 50% air-50% helium and made excursion dives as deep as 330 feet using open-circuit SCUBA.



Figure 9-13 Divers starting excursion dives from the DDS MK 2 PTC during Sealab experiments.

Since that time experimental investigation has shown that the latitude for excursion dives is quite wide. For example, a diver saturated at 300 feet could descend an additional 91 feet for an unlimited time, and return directly to the saturation depth. From a saturation depth of 500 feet, a diver could descend to 619 feet for as long as required without imposing any decompression requirements.

It is standard USN practice to limit the depth of excursion dives to preclude the need for in-water decompression. In an emergency exceeding these limits, however, the capsule can be pressurized to a greater depth for safe transfer of the diver. Excursion to shallower depths are permitted with the unlimited duration excursion limits for saturation diving.

MIXED-GAS PHYSICS 9.2

The fundamental laws and concepts of underwater physics presented in Volume I are basic to a proper understanding of mixed-gas diving techniques. The air diver, functioning with a fixed composition breathing media, seldom needs to perform many calculations requiring the use of the various gas laws. In mixed-gas diving, however, such calculations are vital to safe diving.

A thorough working knowledge of the application of the gas laws is mandatory for the mixed-gas diver, and consequently, a review of the Gas Laws is presented in the following sections. For each underwater breathing apparatus, a section for calculations is included.

Boyle's Law 9.2.1 At constant temperature the absolute pressure and the volume of a gas are inversely proportional. As pressure is increased volume is reduced; as pressure is reduced volume is increased.

Expressed as a formula—

$$P = \frac{1}{V} C$$

or $PV = C$

Where: P = absolute pressure
V = volume
C = a constant

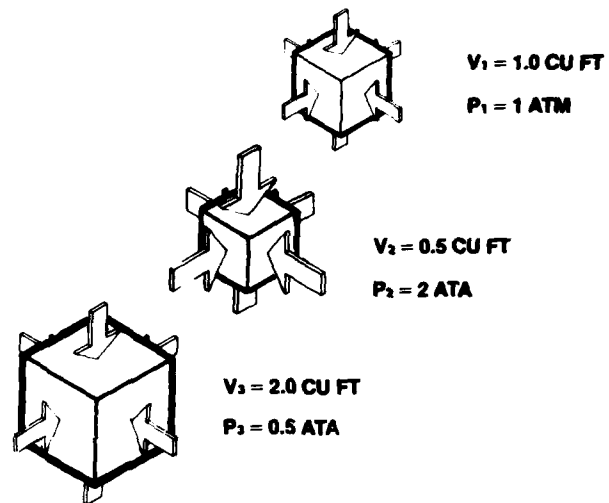

Figure 9-14 Boyle's Law—These figures illustrate the changes in volume due to changes in pressure.

Example No. 1

Problem—The average gas flow requirement of a diver using a Mk I mask and doing moderate work is 1.4 cu ft/min when measured at the depth of the diver. What will be the gas requirement, expressed in volume/minute at surface conditions, for a diver working at 132 feet?—231 feet?—297 feet?

Solution—Since $PV = C$, then (using subscript 1 for surface conditions and subscript 2 for depth conditions),

$$P_1 V_1 = P_2 V_2$$

at the surface

$$P_1 = 1 \text{ ata}$$

$$V_1 = \text{unknown}$$

at 132 feet

$$P_2 = \frac{132 \text{ ft}}{33 \text{ ft/atm}} + 1 \text{ atm} = 5 \text{ ata}$$

$$V_2 = 1.4 \text{ cu ft/min}$$

the gas flow (measured at surface conditions) required to support diving at 132 feet is then,

$$V_1 = \frac{P_2 V_2}{P_1}$$

$$V_1 = \frac{5 \text{ ata} \times 1.4 \text{ cu ft/min}}{1 \text{ ata}}$$

$$V_1 = 7.0 \text{ cu ft/min}$$

at 231 feet

$$P_2 = \frac{231 \text{ ft}}{33 \text{ ft/atm}} + 1 \text{ atm} = 8 \text{ ata}$$

therefore;

$$V_1 = \frac{8 \text{ ata} \times 1.4 \text{ cu ft/min}}{1 \text{ ata}}$$

$$V_1 = 11.2 \text{ cu ft/min}$$

at 297 feet

$$P_2 = \frac{297 \text{ ft}}{33 \text{ ft/atm}} + 1 \text{ atm} = 10 \text{ ata}$$

therefore;

$$V_1 = \frac{10 \text{ ata} \times 1.4 \text{ cu ft/min}}{1 \text{ ata}}$$

$$V_1 = 14.0 \text{ cu ft/min}$$

Example No. 2

Problem—An open diving bell of 100 ft³ internal volume is to be used to support a diver at 198 feet. What volume of helium-oxygen (measured at surface conditions) must be added to the original 1 atmosphere of air in the bell to balance the water pressure at depth? If the bell is lowered to 297 feet after pressurization to 198 feet and no more gas is added, what will be the gas volume in the bell?

Solution—To determine the volume of He-O₂ required to pressurize the bell to 198 feet (V₁)—

$$P_1 = 1 \text{ ata}$$

$$V_1 = \text{unknown}$$

$$P_2 = \frac{198 \text{ ft}}{33 \text{ feet/atm}} = 6 \text{ ata}$$

$$V_2 = 100 \text{ cu ft}$$

$$V_1 = \frac{P_2 V_2}{P_1} = \frac{6 \text{ ata} \times 100 \text{ ft}^3}{1 \text{ ata}} = 600 \text{ cu ft}$$

To determine the volume of gas in the bell at 297 feet (V₃)—

$$P_2 = \frac{198 \text{ ft}}{33 \text{ ft/atm}} + 1 \text{ atm} = 7 \text{ ata}$$

$$V_2 = 100 \text{ cu ft}; P_3 = \frac{297 \text{ ft}}{33 \text{ ft/atm}} + 1 \text{ ata} = 10 \text{ ata}$$

$$V_3 = \text{unknown gas}$$

$$V_3 = \frac{P_2 V_2}{P_3}$$

$$V_3 = \frac{7 \text{ ata} \times 100 \text{ cu ft}}{10 \text{ ata}} = 70 \text{ cu ft}$$

Charles' Law 9.2.2 At constant pressure the volume of a gas is directly proportional to the change in the absolute temperature. If the pressure

is kept constant and the absolute temperature is doubled, the volume will double. If temperature decreases, so does volume. Also if volume rather than pressure is kept constant, as by heating gas in a rigid container, then the absolute pressure will change in proportion to the absolute temperature.

Expressed as a formula (constant pressure)—

$$V_2 = V_1 \frac{T_2}{T_1}$$

Expressed as a formula (constant volume);

$$P_2 = P_1 \frac{T_2}{T_1}$$

Where:

P₁ = initial absolute pressure

P₂ = final absolute pressure

V₁ = initial volume

V₂ = final volume

T₁ = initial absolute temperature

T₂ = final absolute temperature

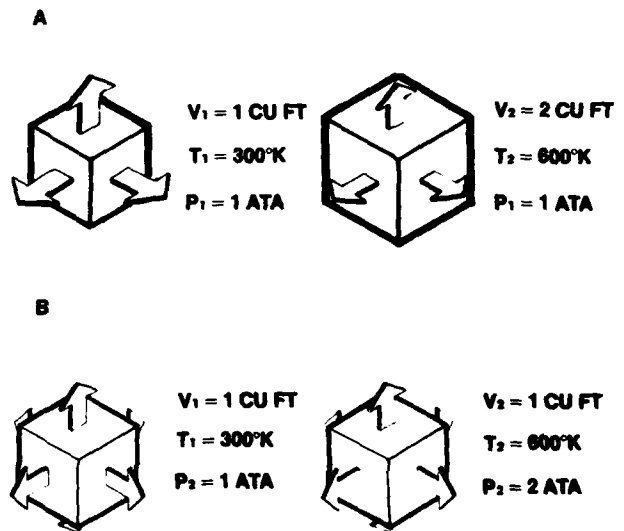

Figure 9-15 Charles' Law—

A If the pressure is held constant the volume varies with changes in the absolute temperature.

B If the volume is constant the pressure varies with changes in absolute temperature.

Example No. 1

Problem—The onboard gas supply of a PTC is charged on deck to 3,000 psig in an ambient temperature of 32°C. The capsule is deployed to a depth of 850 feet at which the water temperature is 8°C. What will be the pressure in the supply at the new temperature?

Solution—In this example volume is constant, only pressure and temperature change. Using subscripts 1 for original conditions and 2 for final conditions—

$$P_2 = \frac{P_1 T_2}{T_1}$$

Converting to absolute temperature values (metric system)—

$$T_1 = 32^\circ\text{C} + 273 = 305^\circ\text{K}$$

$$T_2 = 7^\circ\text{C} + 273 = 280^\circ\text{K}$$

Converting P_1 to absolute pressure—

$$P_1 = \frac{3,000 \text{ psig}}{14.7 \text{ psi/atm}} + 1 \text{ atm} = 205 \text{ ata}$$

Substituting—

$$P_2 = \frac{P_1 T_2}{T_1} = \frac{205 \text{ ata} \times 280^\circ\text{K}}{305^\circ\text{K}} = 188 \text{ ata}$$

Converting to gage pressure—

$$P_2 = (188 \text{ ata} - 1 \text{ ata}) (14.7 \text{ psi/atm}) = 2,750 \text{ psig}$$

Example No. 2

Problem—A habitat is deployed to a depth of 627 feet at which the water temperature is 40°F. It is pressurized from the surface to bottom pressure, and due to heat of compression the internal temperature rises to 110°F. The entrance hatch is open and the divers begin their work routine. During the next few hours the habitat atmosphere cools down to the surrounding seawater temperature because of malfunction in the internal heating system. If no additional gas was added to the habitat, what percentage of the internal volume would be flooded by seawater?

Solution—In this example pressure is constant, only volume and temperature change.

$$V_2 = \frac{V_1 T_2}{T_1}$$

Converting to absolute temperature values (English system)—

$$T_1 = 110^\circ\text{F} + 460 = 570^\circ\text{R}$$

$$T_2 = 40^\circ\text{F} + 460 = 500^\circ\text{R}$$

Substituting—

$$V_2 = \frac{V_1 T_2}{T_1} = V_1 \times \frac{500^\circ\text{R}}{570^\circ\text{R}} = 0.88 V_1$$

Changing to Percent—

$$V_2 = (0.88 V_1) (100\%) = 88\% V_1$$

$$\text{Flooded Volume} = 100\% - 88\% = 12\%$$

General Gas Law 9.2.3 The General Gas Law is a combination of Boyle's and Charles' laws which relates pressure, volume, and temperature.

Expressed as a formula—

$$\frac{P_1 V_1}{T_1} = \frac{P_2 V_2}{T_2}$$

Where—

P_1 = initial pressure (absolute)

V_1 = initial volume

T_1 = initial temperature (absolute)

P_2 = final pressure (absolute)

V_2 = final volume

T_2 = final temperature (absolute)

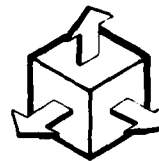

$V_1 = 2 \text{ CU FT}$

$T_1 = 300^\circ\text{K}$

$P_1 = 2 \text{ ATA}$

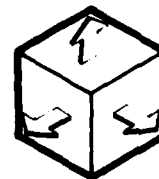

$V_2 = 1 \text{ CU FT}$

$T_2 = 600^\circ\text{K}$

$P_2 = 8 \text{ ATA}$

Figure 9-16 General Gas Law—relates temperature, pressure and volume changes of gases.

The following should be noted in using the General Gas Law—

1. There can be only one unknown.
2. If it is known that a value remains unchanged (such as the volume of a tank) or that the change in one of the variables will be of little consequence, cancel the value out of both sides of the equation to simplify the computations.

Example No. 1

Problem—A bank of cylinders having an internal volume of 20 cubic feet is to be charged with helium and oxygen to a final pressure of 2,200 psig to provide mixed gas for a dive. The cylinders are rapidly charged from a large premixed supply, and the gas temperature in the cylinders rises to 160°F by the time final pressure is reached. The temperature in the cylinder bank compartment is 75°F.

- A. What will be the final cylinder pressure when the cylinders have cooled to ambient temperature?
- B. How many cubic feet of gas at normal temperature and pressure (NTP=70°F, 14.7 psia) will the bank contain?
- C. How much gas at NTP would have been stored if the bank was charged slowly to 2,200 psig and the gas temperature had remained at 75°F?

Solution—

A. To determine the final cylinder pressure when the gas has cooled—

$$P_1 = 2,200 \text{ psig} + 14.7 \text{ psi} = 2,214.7 \text{ psia}$$

$$T_1 = 160^\circ\text{F} + 460 = 620^\circ\text{R}$$

$$T_2 = 75^\circ\text{F} + 460 = 535^\circ\text{R}$$

$$P_2 = \text{unknown} \quad V_1 = V_2 = \text{constant}$$

$$\frac{P_1 V_1}{T_1} = \frac{P_2 V_2}{T_2}$$

Cancelling V on both sides of the equation and rearranging—

$$P_2 = \frac{P_1 T_2}{T_1}$$

Substituting—

$$P_2 = \frac{2,214.7 \text{ psia} \times 535^\circ\text{R}}{620^\circ\text{R}} = 1,911.0 \text{ psia} = 1,896.3 \text{ psig}$$

B. To determine the volume of gas at NTP resulting from the rapid charging—

$$P_1 = 2,214.7 \text{ psia}$$

$$T_1 = 620^\circ\text{R}$$

$$V_1 = 20 \text{ ft}^3$$

$$P_2 = 14.7 \text{ psia}$$

$$T_2 = 70^\circ\text{F} + 460 = 530^\circ\text{R}$$

$$V_2 = \text{unknown}$$

Rearranging—

$$V_2 = \frac{P_1 V_1 T_2}{P_2 T_1}$$

Substituting—

$$V_2 = \frac{2,214.7 \text{ psia} \times 20 \text{ ft}^3 \times 530^\circ\text{R}}{14.7 \text{ psia} \times 620^\circ\text{R}} = 2,576 \text{ cu ft NTP}$$

C. To determine the volume of gas at NTP resulting from the slow charging—

$$P_1 = 2,214.7 \text{ psia}$$

$$T_1 = 535^\circ\text{R}$$

$$V_1 = 20 \text{ ft}^3$$

$$P_2 = 14.7 \text{ psia}$$

$$T_2 = 530^\circ\text{R}$$

$$V_2 = \text{unknown}$$

Substituting—

$$V_2 = \frac{P_1 V_1 T_2}{P_2 T_1}$$

$$V_2 = \frac{2,214.7 \text{ psia} \times 20 \text{ ft}^3 \times 530^\circ\text{R}}{14.7 \text{ psia} \times 535^\circ\text{R}} = 2,985 \text{ cu ft NTP}$$

Example No. 2

Problem—A 100 cubic foot salvage bag is to be used to lift a 3,200 pound torpedo from the seafloor at a depth of 231 feet. An air compressor with a suction of 120 cubic feet/min. at 60°F and a discharge temperature of 140°F is to be used to inflate the bag. Water temperature at depth is 55°F. Neglecting torpedo dis-

placement, breakout forces, compressor efficiency and the weight of the salvage bag, how long will it be before the torpedo starts to rise?

Solution—Displacement of bag to lift torpedo =

$$\frac{3,200 \text{ lb}}{64 \text{ lb/ft}^3} = 50 \text{ ft}^3$$

$V_1 = \text{unknown}$

$P_1 = 1 \text{ ata}$

$T_1 = 60^\circ\text{F} + 460 = 520^\circ\text{R}$

$V_2 = 50 \text{ ft}^3$

$$P_2 = \frac{231 \text{ ft}}{33 \text{ ft/atm}} + 1 \text{ atm} = 8 \text{ ata}$$

$T_2 = 55^\circ\text{F} + 460 = 515^\circ\text{R}$

Rearranging and Substituting—

$$V_1 = \frac{P_2 V_2 T_1}{P_1 T_2}$$

$$V_1 = \frac{8 \text{ ata} \times 50 \text{ ft}^3 \times 520^\circ\text{R}}{1 \text{ ata} \times 515^\circ\text{R}} = 403.8 \text{ ft}^3$$

$$\text{Time} = \frac{\text{Volume Required}}{\text{Compressor Displacement}} =$$

$$\frac{403.8 \text{ ft}^3}{120 \text{ ft}^3/\text{min}} = 3.4 \text{ min}$$

(Note that the 140°F compressor discharge temperature is an intermediate temperature and does not enter into the problem.)

Dalton's Law 9.2.4 The total pressure exerted by a mixture of gases is equal to the sum of the pressures of the different gases making up the mixture—each gas acting as if it alone were present and occupied the total volume. The pressure contributed by any gas in the mixture is proportional to the number of molecules of that gas in the total volume. The pressure of that gas is called its **partial pressure** (pp), meaning its part of the whole.

Expressed as a formula—

$$P (\text{Total}) = pp(A) + pp(B) + pp(C) + \dots$$

Consequently—

$$pp(A) = P (\text{Total}) \times \frac{\% \text{Vol (A)}}{100\%}$$

Depth	Gas Helium 80% Oxygen 20%	Absolute Pressure & Partial Pressures
-------	---------------------------------	---



Surface (1 ATM)

1 ATM = 14.7 psia
Helium: 0.8 ATM, 11.76 psia
Oxygen: 0.2 ATM, 2.94 psia



33 FT (2 ATM)

2 ATM = 29.4 psia
Helium: 1.6 ATM, 23.52 psia
Oxygen: 0.4 ATM, 5.88 psia

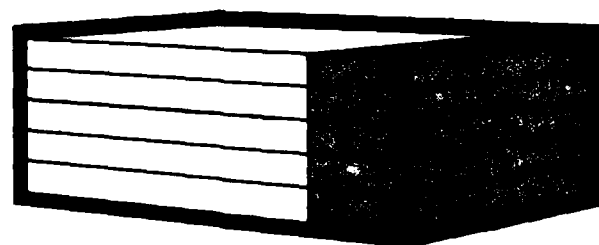

132 FT (5 ATM)

5 ATM = 73.5 psia
Helium: 4.0 ATM, 58.8 psia
Oxygen: 1.0 ATM, 14.7 psia

Figure 9-17 Dalton's Law (The Law of Partial Pressures)

Example No. 1

Problem—A helium-oxygen mixture is to be prepared which will provide an oxygen partial pressure of 1.2 ata at a depth of 231 feet. What should be the oxygen percentage in the mix?

Solution—Convert depth to atmospheres absolute—

$$D = \frac{231 \text{ ft}}{33 \text{ ft/atm}} + 1 \text{ atm} = 8 \text{ ata}$$

Since—

$$pp(A) = P(\text{Total}) \times \frac{\% \text{Vol (A)}}{100\%}$$

Rearranging—

$$\%Vol(A) = \frac{pp(A)}{P(Total)} \times 100\%$$

$$\%Vol(A) = \frac{1.2 \text{ ata}}{8 \text{ ata}} \times 100\% = 15\% \text{ oxygen}$$

Example No. 2

Problem—A 30-minute bottom time dive is to be conducted in 264 feet of seawater. The maximum safe oxygen partial pressure for a 30-minute exposure under normal operating conditions is 1.6 ata (Chapter 15). Two premixed supplies of He-O₂ are aboard—16% O₂ and 22% O₂. Are either of these mixtures safe for the intended dive?

Solution—Convert depth to atmospheres absolute—

$$D = \frac{264 \text{ ft}}{33 \text{ ft/atm}} + 1 \text{ atm} = 9 \text{ ata}$$

The maximum allowable O₂ percentage is found as follows—

$$\%Vol(A) = \frac{pp(A)}{P(Total)} \times 100\%$$

$$\%Vol O_2 = \frac{1.6 \text{ ata}}{9 \text{ ata}} \times 100\% = 17.8\% O_2$$

Result—

The 16% mix is safe to use; the 22% mix is unsafe.

$$\text{The pp of the 16\% mix} = 9 \text{ ata} \times \frac{16\%}{100\%} = 1.44 \text{ ata } O_2$$

and 1.44 ata O₂ is less than the maximum allowable.

$$\text{The pp of the 22\% mix} = 9 \text{ ata} \times \frac{22\%}{100\%} = 1.98 \text{ ata } O_2$$

and use of this mixture would result in a significant risk of oxygen toxicity developing.

Example No. 3

Problem—The gas cylinders aboard a PTC are to be charged with an He-O₂ mixture. The mixture should provide an oxygen partial pressure of 0.9 ata to the diver using a MK I mask at a saturation depth of 660 fsw. What should be the oxygen percentage in the charging gas? If the diver makes an excursion from

saturation depth to 726 fsw what will be the oxygen partial pressure of his breathing gas?

Solution—Convert depth to atmospheres absolute—

$$D = \frac{660 \text{ ft}}{33 \text{ ft/atm}} + 1 \text{ atm} = 21 \text{ ata}$$

The O₂ content of the charging mix is found as follows—

$$\%Vol O_2 = \frac{0.9 \text{ ata}}{21 \text{ ata}} \times 100\% = 4.3\% O_2$$

Convert excursion depth to atmospheres absolute—

$$D = \frac{726 \text{ ft}}{33 \text{ ft/atm}} + 1 \text{ atm} = 23 \text{ ata}$$

The O₂ partial pressure at excursion depth is found as follows—

$$pp O_2 = 23 \text{ ata} \times \frac{4.3\% O_2}{100\%} = 0.99 \text{ ata}$$

Henry's Law 9.2.5 The amount of gas that will dissolve in a liquid at a given temperature is almost directly proportional to the partial pressure of that gas. If one unit of gas is dissolved at one atmosphere partial pressure, then two units will be dissolved at two atmospheres, etc.

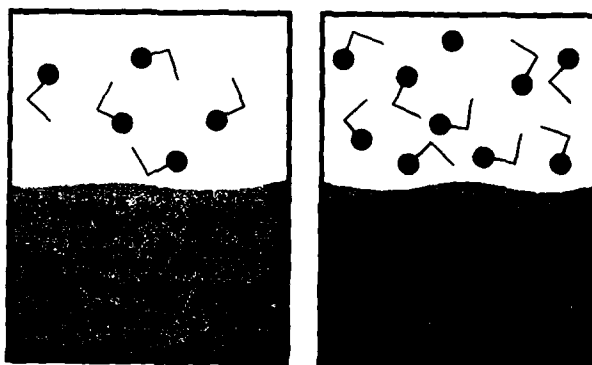

ppGas = 1 ATM

ppGas in solution = 1 ATM

Q = 1 liter dissolved

ppGas = 2 ATM

ppGas in solution = 2 ATM

Q = 2 liters dissolved

Temperature Constant

Figure 9-18 Henry's Law—
the example shown is at equilibrium (solution saturated)

MIXED-GAS DIVING PHYSIOLOGY 9.3

Mixed-gas operations often involve great depths, lengthy exposures to unusual breathing mixtures, and low temperatures. Any of these can seriously impair a diver's working effectiveness and pose continuing problems of health and safety.

The fundamental principles of diving physiology were discussed in *Volume I* and form the foundation for understanding the hyperbaric effects of mixed gas. In this type of diving, however, certain physiological considerations assume added importance and other effects, not previously discussed, are encountered. These concerns are discussed in this section and include—

- Ventilation, breathing resistance and gas transport.
- Oxygen toxicity.
- Use of oxygen in decompression.
- Body heat loss and temperature balance.
- Distortion of speech.
- Other physiological concerns such as compression arthralgia and the high pressure nervous syndrome (HPNS).

Ventilation, Breathing Resistance and Gas Transport 9.3.1

The ability of the cardio-vascular system to circulate blood to various parts of the body determines a man's capacity to do heavy work at the surface. At great depth, work capacity is more directly determined by the effectiveness of pulmonary ventilation. The factor tending to limit thorough ventilation at depth is that the density of the breathing mixture causes increased resistance to gas movement.

Experiments have demonstrated that men can perform moderate work to depths greater than 1,000 feet while breathing helium-oxygen in a dry chamber. The density of the helium-oxygen at 1,000 feet is 4.3 times that of air at the surface or about the same as air breathed at 110 feet.

Figure No. 9-19 illustrates the effect of increased gas density upon pulmonary ventilation. Maximum voluntary ventilation (MVV) is the maximum gas volume that can be breathed per minute by voluntary effort. The minute respiratory volume measured during maximum

exercise is usually less than the MVV. As will be noted in the illustration, the MVV decreases at greater gas densities as the depth is increased. Deterioration in pulmonary ventilation is particularly pronounced as the diver descends from the surface to 1,000 feet. Actual measurements have been made to 1,600 feet and greater depths have been simulated with breathing gases denser than helium. Therefore, this curve graphically illustrates the reduction in maximum exercise levels that can be expected of divers in dry chambers at these depths. Immersed divers, because of UBA breathing resistance and effects of immersion, are further limited.

EFFECT ON MAXIMUM VOLUNTARY VENTILATION OF INCREASED ATMOSPHERIC PRESSURE

% Decrement in MVV

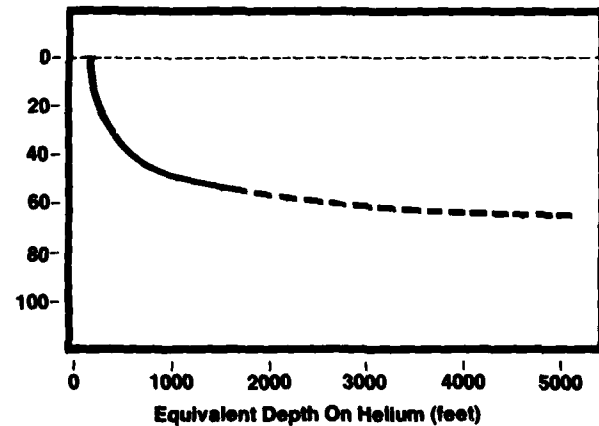

Figure 9-19 Curve of Maximum Voluntary Ventilation vs. Depth.

The ultimate hydrostatic pressure levels under which man may function have not yet been determined. In dry chamber experiments with various breathing mixtures, helium has been successfully tested to 2,000 feet, neon to 1,000 feet, and nitrogen-oxygen below 300 feet. Helium produced no noticeable effects, and presumably, actual saturation diving using helium will eventually prove feasible at least to that test level. Neon seems to impose no mental or physiological limitations, but because it is more dense than helium,

problems of pulmonary ventilation may impose a working limit below some depth (estimated to be 700 feet). Saturation exposures with nitrogen are usually limited to about 100 feet. The limiting factors with nitrogen are both respiratory functions and the narcotic effect at increased pressure. The limiting factor with air is the inevitability of lung damage from prolonged exposure to elevated oxygen partial pressures.

A consideration with both nitrogen-oxygen mixtures and air is the greater density (compared with helium mixtures) which interferes with pulmonary ventilation. At any given depth ventilation will be superior with a less dense gas, and in some operations (such as when using mixed-gas SCUBA which includes the additional factors of equipment-related breathing resistance and dead space) the difference in breathing effectiveness can be significant. The retention of carbon dioxide because of inadequate ventilation will not only limit the diver's capacity for work but may facilitate the onset of other problems, most notably oxygen poisoning and nitrogen narcosis.

Oxygen Toxicity 9.3.2 In contrast with air operations, it is an inherent capability in mixed-gas diving to be able to vary the oxygen level of the diver's breathing medium. This flexibility introduces the hazard of accidental oxygen toxicity.

There are two major expressions of oxygen poisoning — one that involves effects of oxygen upon the central nervous system (and often results in a convulsion similar to that of an epileptic seizure), and the other which leads to severe irritation of the lung.

Central nervous system poisoning is dependent upon the partial pressure of the inspired oxygen and the duration of exposure. Pulmonary oxygen poisoning and accompanying lung damage is also specifically related to the duration of exposure to higher-than-normal levels of oxygen. Pulmonary oxygen toxicity is rarely a problem in surface-supplied diving operations due to the short exposure time. However, because of the extended bottom times encountered in mixed-gas (particularly saturation) diving, the possibility of pulmonary involvement is greatly increased.

CENTRAL NERVOUS SYSTEM (CNS) OXYGEN POISONING 9.3.2.1 Central nervous system oxygen poisoning becomes a distinct possibility when the

partial pressure of inspired oxygen reaches 1.6 atmospheres. The percentage of oxygen in the breathing mixture is not in itself the significant factor. A diver breathing 100% oxygen at 20 feet or air at 220 feet breathes an oxygen partial pressure level of 1.6 atmospheres. Most divers can tolerate an oxygen partial pressure of 2.0 atmospheres for many hours at rest, and some divers can exceed that level without apparent difficulty related to CNS O₂ toxicity. In addition to individual differences in the ability to withstand such exposure, the length of time before symptoms appear is influenced by other factors—

— **The level of exertion.** Experimentally, most men at complete rest in a dry chamber can breathe pure oxygen for as long as 2 hours at a simulated depth of 60 feet. However, at that depth and doing even light work, symptoms may begin to be experienced within 15 minutes.

— **Carbon dioxide retention** resulting from resistance in the breathing apparatus, inadequate ventilation of the diver's lungs or excess CO₂ in the inspired mixed gas. The resultant buildup of carbon dioxide speeds the onset of oxygen poisoning symptoms.

— **Intermittent exposure** to high oxygen partial pressures. If the level of oxygen in the breathing mixture is alternated between a high value and a low one, the diver can be exposed to a higher total amount of oxygen before the development of symptoms of poisoning. Also, if the partial pressure of oxygen is reduced at the first signs or symptoms of poisoning, the condition will be reversed if it has not already entered a progressive stage. These factors are important when oxygen is used in decompression or in any therapeutic application.

As a result of extensive experimentation and years of field experience, oxygen partial pressure/exposure time limits have been established for the conduct of mixed-gas working dives. These limits, given in Figure No. 9-20, should not be exceeded in operating situations except as required in certain standard decompression procedures when the diver is at rest. The limits apply to nitrogen-oxygen SCUBA diving and helium oxygen surface-supplied diving where carbon

OXYGEN PARTIAL PRESSURE LIMITS TABLE
Exposure Time **Maximum Oxygen Partial**
(min.) **Pressure (atmospheres)**

NORMAL EXPOSURES

30	1.6
40	1.5
50	1.4
60	1.3
80	1.2
120	1.1
240	1.0

EXCEPTIONAL EXPOSURES

30	2.0
40	1.9
60	1.8
80	1.7
100	1.6
120	1.5
180	1.4
240	1.3

Figure 9-20 Oxygen partial pressure limits for nitrogen-oxygen SCUBA and surface-supplied helium-oxygen mixed-gas diving.

dioxide retention or very heavy work is anticipated. Helium-oxygen SCUBA limits allow greater exposure.

The warning symptoms of central nervous system oxygen poisoning may vary, not all possible symptoms are likely to occur in each instance, and in some cases there may even be an absence of warning symptoms entirely. Some of the symptoms may easily be the result of other physiological problems and some may even reflect the approach of **hypoxia**—a condition resulting from an inadequate supply of oxygen rather than an overabundance.

The most common symptoms may be remembered by the acronym **V-E-N-T-I-D**—

- Vision.** Any abnormality, such as "tunnel vision" (a contraction of the normal field of vision as if looking through a tube.)
- Ears.** Any abnormality of hearing.
- Nausea.** This may be intermittent.
- Twitching.** Usually appears first in the lips or other facial muscles, but may affect any muscle. This is the most frequent and clearest warning of oxygen poisoning.

- Irritability.** Any change in behavior including anxiety, confusion, unusual fatigue.
- Dizziness.**

Additional symptoms may include difficulty in taking a full breath, an apparent increase in breathing resistance, noticeable clumsiness or incoordination.

When the poisoning reaches an acute level, the victim will suffer convulsive seizure. The entire body is seized in a violent spasm which soon changes to a series of jerking movements of the limbs, trunk, head and face. Frothy saliva (which may be mixed with blood if the tongue or cheek has been bitten) is blown from the lips. After a minute or two, the jerking will decrease and eventually cease. At this point the victim may be in a deep coma from which he will slowly regain consciousness (perhaps exhibiting some irrationality). After a period which may vary from 15 minutes to an hour, he will be generally recovered, will usually feel exhausted and may have a headache. He will probably not remember many details of the episode. If the level of oxygen is not reduced, the convulsion cycle may repeat with increasingly serious consequences.

The convulsion itself is not particularly dangerous to the victim, although some physical damage—such as collapsed vertebrae or a badly chewed tongue—may occur. The principal dangers arise from the loss of control while in the diving environment. In a open sea diving dress the convulsion could precipitate a blowup or squeeze and might conceivably result in a gas embolism if the diver is brought too quickly to the surface. With SCUBA the major danger is that of drowning.

Central nervous system oxygen poisoning can largely be prevented by observance of the following guidelines—

- Never exceed the depth/time limits prescribed for each type of apparatus and breathing mixture.
- Never use oxygen in any concentration except as designated in the decompression tables and operating instructions for the apparatus. (For example, never use oxygen in an open-circuit SCUBA.)

- Ensure that the breathing apparatus is in good order.
- Observe safety precautions.
- Avoid excessive exertion.
- Heed any abnormal symptoms, however slight.

If symptoms are observed, a prompt lowering of the oxygen partial pressure will usually avert the onset of convulsions. However, even if the diver suffers from a convulsion and the level of oxygen is not changed, the convulsion will usually complete its cycle and the diver's condition will return to near-normal. The level must be reduced as soon as practical to prevent further seizures.

A diver who is suffering from a convulsion should be prevented from injuring himself. A buddy diver is the best insurance against drowning in a SCUBA operation. If the seizure should occur while in a recompression chamber, the tender should keep the victim from thrashing against hard objects, but complete restraint of movement is neither necessary nor desirable. The use of a mouth bit (such as several tongue depressors wrapped in tape) will help avoid damage to the victim's tongue or cheeks. Ordinarily a man will suffer *no lasting effects of a seizure*, and there is no evidence that he will be any more or less susceptible to oxygen poisoning in the future.

PULMONARY OXYGEN POISONING 9.3.2.2 Pulmonary oxygen poisoning, with irritation or damage to the lungs, results from prolonged exposures to oxygen at partial pressures above 0.5 atmospheres. At higher partial pressure (approximately 2.0 to 3.0 atmospheres), central nervous system poisoning will likely occur before lung damage becomes apparent. The length of exposure time required to produce symptoms varies with the partial pressure of inspired oxygen, as well as with individual tolerances. Pulmonary toxicity develops more rapidly at higher oxygen partial pressures. Figure No. 9-21 illustrates the time/partial pressure relationships. The symptoms of pulmonary oxygen poisoning are not as dramatic as those of central nervous system toxicity, and the onset of lung damage is insidious and progressive.

The first symptoms, related to inflammation of the lining of the air passages, are likely to be painful breathing (especially deep breathing) and intermittent cough-

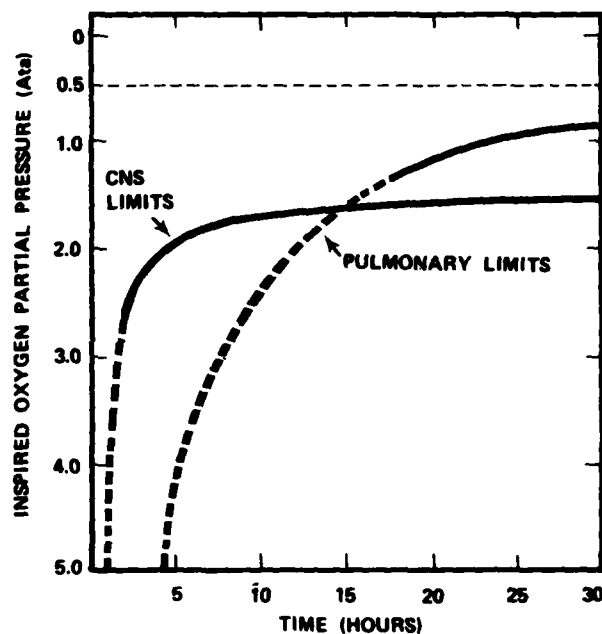

Figure 9-21 Time/O₂ partial pressure relationships.

ing. As the damage progresses these symptoms become more severe and the coughing may become uncontrollable.

The alveoli and lung capillaries become affected, and the lungs eventually lose the ability to handle the movement of oxygen from the airways to the blood. Thus, in fatal cases, death is actually due to hypoxia of the vital organs even though the cause of the problem is an excess of oxygen in the lungs.

In the early stages of pulmonary oxygen poisoning the damage is completely reversible after the exposure ceases. This permits the use of oxygen at elevated pressures when the exposure is carefully controlled. When used to aid decompression, the level should be kept below that which produces any detectable lung damage. However, in using oxygen to treat a disease, the medical officer in charge may elect to accept mild or even moderate lung damage that is reversible in order to better treat a more serious problem.

Pulmonary oxygen poisoning can arise in non-saturation diving (whether on air, mixed gas or oxygen), but the exposure is usually not long enough to produce any symptoms or detectable damage. The primary

hazard occurs in saturation diving and prolonged decompression. The lower level of inspired oxygen partial pressure which will cause no toxicity for very long exposures is not known with certainty. Experimentally, 0.5 atmospheres have been tolerated.

Use of Oxygen and Other Gases in Decompression

9.3.3 At all stages of decompression, the rate of elimination of an inert gas can be increased by a reduction in the partial pressure of that gas in the breathing mixture while maintaining the total pressure. This will increase the outward pressure. This will increase the outward pressure gradient, and can be accomplished by the substitution of another inert gas or by increasing the proportion of oxygen in the breathing mixture. As a consequence, decompression time can be shortened at the expense of increased procedural complexity.

The use of multiple inert gases during decompression is still in the experimental stage. It is not unusual, however, to use air or nitrogen-oxygen during decompression following an He-O₂ dive. Some of the nitrogen will be absorbed by body tissues, but helium will be more rapidly eliminated and the overall effect may be a reduction in the total inert gas loading in the body. One side effect of this type of procedure is the eventual development of skin itch if the exposure is long enough. At depths greater than 100 feet, if the body is surrounded by a helium-oxygen mixture (as in a PTC) and the diver is breathing nitrogen-oxygen through a mask, gas gradients can develop through the skin, resulting in severe itching similar to skin bends, due to the formation of bubbles in the skin tissues.

One hundred percent oxygen is commonly used for breathing during various phases of decompression from mixed-gas dives. Since oxygen is consumed by the body, it does not contribute to the gas loading which must be reduced to provide safe decompression. Maintenance of the total pressure by pure oxygen deters inert gas bubble formation and resulting decompression sickness while permitting high outward inert gas gradients to exist. This procedure, however, can only be used during the shallower portions of the decompression profile because of the toxicity hazards previously discussed. Furnished to the diver at specified points in the decompression cycle, this

additional oxygen accelerates the release of inert gas from the body tissues. Despite its advantages in decompression, oxygen should not be used indiscriminately.

Body Heat Loss and Temperature Balance 9.3.4

Maintenance of acceptable body temperature is a problem in virtually all diving operations. However, any diving operation involving helium-oxygen mixtures will pose more serious temperature control problems; and if the dive is in deep, cold water, active measures must be taken to protect the diver and conserve his body heat as much as possible. An additional factor, which further complicates maintenance of uniform body temperatures, is introduced by the widely varying levels of work (and therefore heat production) experienced in both saturation and non-saturation dives.

The high thermal conductivity of helium (approximately 6 times that of air) draws heat away from the diver at a great rate; and the colder the environment, the more severe the problem. Providing the diver with insulating clothing will help, but the high pressures encountered in deep-diving reduce the effectiveness of insulating clothing by compressing the material. The effectiveness is further reduced in a helium atmosphere since helium tends to replace whatever gas is trapped in the "air spaces" of the material. At a depth of 600 feet, for example, a 3/16-inch neoprene wet suit in a helium environment would have one-fourth its normal surface-insulating value.

In deep diving operations some form of external heat must be provided to the diver to maintain thermal balance and prevent chilling or hypothermia. Several methods for providing heat to the diver have been tested and some are operational. The most successful to date has been the use of suits and inspired gas heaters provided with circulating hot water from the surface or from a PTC.

Breathing cold helium-oxygen at deep saturation diving depths can cause incapacitating copious nasal and trachea-bronchial secretions, difficulty breathing, chest pain, headache and severe shivering. These distressing symptoms may begin within minutes. Even breathing cool, apparently comfortable, temperature helium-oxygen at deep depths can rapidly lower body temperature through respiratory heat loss even while the skin is kept warm. The diver usually remains

unaware of the respiratory heat loss, has no symptoms, and will not begin to shiver until the rectal temperature has fallen. Even then, metabolic heat production will not compensate for the continuing respiratory heat loss.

Figure 9-22, U.S. Navy Minimum Inspired Gas Temperature Limits, provides the minimum allowable temperatures for helium-oxygen breathing gas when all other steps have been taken to keep the diver warm. The limits are based upon a maximum convective respiratory heat loss of 20 watts per square meter of body surface for a resting diver whose skin warmth is maintained to his comfort by a hot water suit. This level of respiratory heat loss is predicted to prevent rectal temperature drop greater than 0.25°C (0.45°F) hourly or 1.0°C (1.8°F) in four hours.

When operating in a habitat or a PTC, the range of temperature in which a diver will feel reasonably comfortable will vary with depth. For example, using helium-oxygen at a depth of 400 feet, the average diver will accept a temperature range of about 3°C—from 28.5°C to 31.5°C. At 1,200 feet the range is reduced to 1°C and the comfort level has shifted upward so that the low limit is now 32.5°C. Clearly, small changes in ambient temperature produce major changes in comfort for the diver.

Distortion of Speech 9.3.5 One other physiological problem encountered in mixed-gas diving when using helium mixtures is the so-called "Donald Duck" effect upon human speech. The exact reasons for this effect are not fully understood and may involve both the vocal chords and the resonant passages of chest, throat and head. With experience, divers and tenders can learn to overcome some of the communications interference imposed by the distorted speech. Electronic speech "unscramblers" offer a definite benefit. The speech impairment is temporary and without lasting effect on the diver and will markedly improve when other breathing mixtures are substituted for helium. The principal hazard with distorted speech is that vital communications from the diver might not be understood.

Other Physiological Concerns 9.3.6 Certain physiological phenomena have been observed in both dry chamber pressure tests and in actual deep-diving operations which may be linked to a variety of factors:

Depth (FSW)	Minimum Inspired Gas Temperature	
	(°C)	(°F)
300	-1.0	30.2
400	6.0	42.8
500	11.5	52.7
600	14.1	57.9
700	17.0	62.6
800	18.7	65.7
900	20.5	68.9
1000	21.9	71.4
1100	22.7	72.9
1200	23.7	74.7
1300	24.6	76.3
1400	25.3	77.5
1500	25.9	78.6

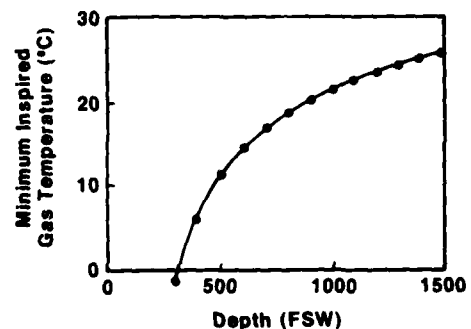

Figure 9-22 Proposed minimum inspired helium-oxygen temperatures for saturation depths between 300 and 1500 FSW.

high ambient pressure, high rates of change in pressure, changes in the composition of the breathing mixture or, possibly, to the constituent gases in the breathing mixture. The exact causes are not yet clear. These phenomena include—

- Joint pains may be experienced during compression or may appear at some point in time after arriving at maximum depth. These pains tend to improve after a few hours or days. The pains are not debilitating but may pose a handicap to the normal conduct of operations. Experimentally, the joint pains seem to be precipitated by rapid and large pressure changes.
- High Pressure Nervous Syndrome (HPNS) includes certain diverse general symptoms which have been clinically described. Muscular tremors (sometimes called "Helium Tremor") have been observed in experimental exposures of exceptional depth. The cause is unknown.

Other symptoms including dizziness, nausea, decreased alertness, and a desire to sleep. Electroencephalograph (EEG) changes have also been noted. A high rate of compression is thought to be a contributing (although not an exclusive) factor in production of these symptoms.

CHAPTER TEN

OPERATIONS PLANNING

Mixed-gas diving operations are complex, require close coordination and constant support, and (as a consequence of extended decompression obligations) can be hazardous if improperly planned or executed. If a problem should arise it must be handled as an emergency, and there will be little time to search through manuals or operations orders seeking an approved course of action.

The planning for a mixed-gas operation must be thorough, correct, and involve all support units and personnel as well as the diving team itself. Planning is necessarily more extensive than with air diving. Requirements for surface support are greatly increased and are usually dependent upon the availability of appropriately equipped support vessels. Gas supply factors are critical and must be determined far enough in advance to ensure that adequate quantities of the correct gas mixtures will be on station.

If the operation includes saturation dives, the planning effort will be even more complicated. For example, a saturation dive requires 24-hour topside support, day in and day out, with a fully qualified team on station at all times. Thus, keeping two men at the work site in a saturation dive could require at least three times the number of topside personnel as would a non-saturation dive. Additionally, surface support vessels assigned to the operation must be able to physically handle habitats and/or personnel transfer capsules, have sufficient space for the installation of deck decompression chambers, and be able to provide the submerged divers with heat and power for the duration of the operation.

Volume I, Chapter Four (Operations Planning) is a comprehensive introduction to the planning of diving operations using surface-supplied air or open-circuit SCUBA. The material presented in that chapter is applicable to mixed-gas operations as well, although specific aspects of such operations are not directly covered. These aspects will be discussed in the following sections which are organized to follow the general format of Volume I, Chapter Four. This manner of presentation will serve also as a brief review of the overall subject of dive planning.

The basic planning steps which will be described are—

- Define objectives.
- Collect and analyze data.
- Establish operational tasks.
- Select diving technique.
- Select and assemble the diving team.
- Brief the diving team.
- External ear prophylaxis.
- Gas supply.
- Hyperbaric flammability.
- Chamber atmosphere contamination.

DEFINE OBJECTIVES 10.1

Why is the operation being undertaken, and what is to be accomplished?

Factors which will influence the choice of mixed gas, rather than air diving or no diving at all, will include the depth of the work site, the estimated length of time required to complete the job and the availability of specialized equipment. In general—

- For deep dives of short duration or for shallower dives where absolute mental acuity and physical dexterity are required, surface-supplied mixed gas may be the method of choice.
- For dives below 300 feet or for dives in shallower levels where extensive underwater times are indicated, saturation diving is the technique of choice.
- A habitat is best suited to operations requiring close and constant observation of a single work area, as in scientific investigation. For other types of operations the safety and comfort of the divers in a saturation dive will be better supported with the use of personnel transfer capsules and deck decompression chambers. In general, a habitat requires greater levels of surface support and greatly limits the mobility and flexibility of the support units.

COLLECT AND ANALYZE DATA 10.2

This data will include information about environmental conditions at the dive site (bottom conditions, tides and currents, weather), specific information about the resources available for the conduct of the operation including the availability of logistic and emergency assistance. Analysis of such data will aid in the selection of the dive technique and divers, in the identification of potential hazards, and in making allowances for contingencies which might arise.

ESTABLISH OPERATIONAL TASKS 10.3

Tasks embracing the entire operation from the planning stage to final post-dive activities must be established. Prepare a basic outline for the operation and ensure that all phases will be properly coordinated and that all identifiable tasks are assigned to responsible units or individuals.

SELECT DIVING TECHNIQUE 10.4

As with air diving operations the principal factors influencing the choice of technique are—

- depth and planned duration of the dive.
- qualifications of personnel.
- type of work and degree of mobility required.
- environmental considerations (temperature, visibility, type of bottom, current, pollution, etc.).

In mixed-gas diving the importance of some of these factors is increased, and additional factors are imposed—

- Since most mixed-gas diving is deep diving (See Table No. 10-1 for depth limits), the divers must be prepared to work at low temperatures and at a distance—in both time and space—from the surface. For such reasons, SCUBA would be generally inappropriate unless employed in conjunction with a personnel transfer capsule (tethered mode) or habitat.

- Mixed-gas SCUBA, except when used from a PTC, is currently limited to use by combat swimmers or EOD personnel.

- Oxygen SCUBA, intended for shallow clandestine operations involving maximum freedom from detection, is not to be used in fleet diving operations. Use of this equipment is restricted to combat swimmers specially qualified by training in its use and hazards.

- The use of lightweight gear MK1 Diver's Mask and the open bell finds particular application in situations which necessitate mobility in the water column. Deep-sea recirculating gear provides the diver comfort and security demanded by particularly adverse environmental conditions and obstructions such as in deep salvage or repair operations.

- Operations below 300 feet, whether saturation or non-saturation, imply the need for DDS equipment. Decompression obligations demands upon the diver that in-water decompression is impractical. Use of a bell system for diver transport and subsequent decompression on deck offers a significant margin of diver safety and support ship flexibility for non-saturation diving in deep and/or adverse environments.

- Surface support and logistic requirements are complex. Large specially-configured ships or diving barges are generally required; the normal small craft used in air diving are usually not appropriate. Currently the only standard fleet vessels equipped to support mixed-gas diving are the ASR (auxiliary submarine rescue) and ATS (auxiliary tug salvage) classes. Since certain other mixed-gas support vessels are unique—such as ships of the ASR-21 class equipped with DDS MK 2—the operations planning may have to include advance inputs to scheduling programs.

- The use of a habitat greatly reduces support flexibility since the topside vessels and other units are literally tied to the work site. The habitat, although on the bottom, is therefore indirectly subject to the sea-keeping problems caused by weather and wave action.

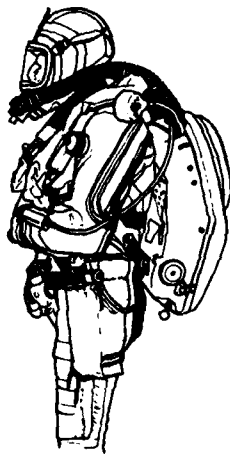
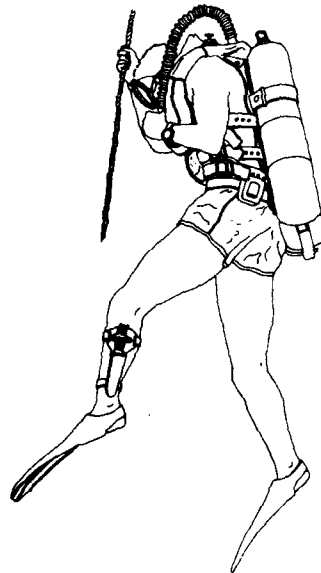

—The level of planning itself may place a significant workload on non-diving administrative personnel.

—All equipment used in mixed-gas and oxygen diving must be U.S. Navy-approved for such service. A list of approved equipment will be found in NAVSEAINST 9597.1 series.

TABLE 10-1. OPERATIONAL DEPTH LIMITS FOR DIVING PROCEDURES.*

Depth Limit		Diving Procedure	Depth Limit		Diving Procedure
(Feet)	(Meters)		(Feet)	(Meters)	
25	7.6	Closed-circuit pure oxygen diving; normal working or swimming limit	180	55	Semi-closed circuit helium-oxygen mixed-gas SCUBA; normal working limit
40	12.2	Closed-circuit pure oxygen; maximum limit	190	58	MK 1 Diver's Mask with roving bell, air
40	12.2	Lightweight diving equipment with Jack Browne Mask	190	58	Surface-supplied diving system MK 12 and MK 5, air; normal working limit
60	18	MK 1 Diver's Mask, air, tethered SCUBA	200	61	Semi-closed circuit helium-oxygen mixed-gas SCUBA; maximum limit
60	18	MK 1 Diver's Mask, surface-supplied, without come-home bottle	250	76	Surface-supplied diving system MK 12 and MK 5, air; maximum limit
130	40	Open-circuit demand SCUBA, air	300	91	Surface-supplied diving system MK 12 and MK 5, helium-oxygen; normal working limit
130	40	Semi-closed circuit nitrogen-oxygen mixed-gas SCUBA; normal working limit	300	91	Surface-supplied MK 1 Diver's Mask with open bell, helium-oxygen; normal working limit
130	40	MK 1 Diver's Mask, air, without roving bell	Below 300	91	Surface-supplied helium-oxygen diving is not to exceed 300-foot depth limit without the direct authorization of the CNO in accordance with OPNAV 9940.1 series.
150	46	MK 15 closed-circuit constant oxygen partial pressure in nitrogen	380	116	Surface-supplied diving system MK 12, MK 5, and MK 1 Diver's Mask, helium-oxygen; maximum limit
170	52	MK 1 Diver's Mask, helium-oxygen, without roving bell	850	259	Deep diving systems used within certification limits of systems and breathing apparatus
170	52	Diving without recompression chamber at site			
170	52	Semi-closed circuit nitrogen-oxygen mixed-gas SCUBA; maximum limit			

***Notes:**

(1). The left-hand column is the depth limit and the right-hand column is the diving procedure limited by the table. Diving is limited in depth by the rules appearing in this table and in duration by the decompression tables. Each underwater breathing apparatus or diving procedure listed has an appropriate decompression table in the manual.

(2). These depth limits are based on considerations of working time, decompression obligation, oxygen tolerance and nitrogen narcosis. Expected duration of gas supply, expected duration of carbon dioxide absorbent, adequacy of thermal protection or other factors may also limit both the depth and duration of a dive.

(3). Semi-closed circuit mixed-gas SCUBA nitrogen-oxygen and helium-oxygen; Surface-supplied diving system MK 12, MK 5 and MK 1 Diver's Mask, air and helium-oxygen; and pure oxygen diving have both normal working and maximum depth limits. Other diving procedures have a single operational depth limit.

(4). A Diving Medical Officer is required for all dives exceeding the normal working limit or the operational depth limit for any underwater breathing apparatus or diving procedure listed.

(5). A Diving Medical Officer is required on the scene for all saturation diving operations. Current operating limits for saturation equipment are as follows:

DDS-MK 2 Mod 0	-850 feet
DDS-MK 2 Mod 1	-850 feet
MK 11 Mod 0 apparatus	-650 feet
MK 1 Mod S Diver's Mask	-1000 feet
MK 14	-1000 feet
Plus excursions 100 feet below the PTC	

OXYGEN DIVING GENERAL CHARACTERISTICS

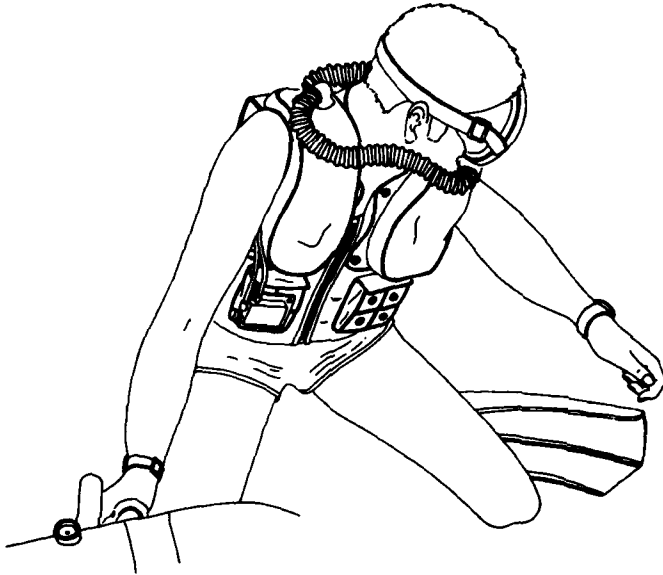

Minimum Equipment—

- Life jacket
- Depth gage
- Facemask
- Swim fins
- Knife
- Wristwatch

Principal Applications—

- Shallow search and inspection
- Clandestine operations

OPERATIONS PLANNING



Figure 10-1 Oxygen rebreather (front view).

Advantages—

- No surface bubbles
- Long duration
- Good mobility
- Rapid deployment
- Portability
- Minimum support

Disadvantages—

- Limited to shallow depths (O₂ Toxicity Hazard)
- No voice communications
- Limited physical protection
- Influenced by current

Restrictions—

Work limits—

- Normal 25 feet/75 minutes
- Maximum 40 feet/10 minutes
- Current—1 knot maximum

Diving team—

- One diver—minimum 4 men
- Two divers—fleet minimum 6 men
- EOD/UDT/SEAL minimum 4 men

Operational Considerations—

- Buddy and stand-by diver required*
- Small boat required for diver recovery
- Avoid use in areas of coral and jagged rock
- Moderate to good visibility preferred
- Buddy diver must be in same type of UBA

*Requirement may be waived by UDT/SEAL diving officer

RECIRCULATING DEEP-SEA DIVING GENERAL CHARACTERISTICS — MK 5

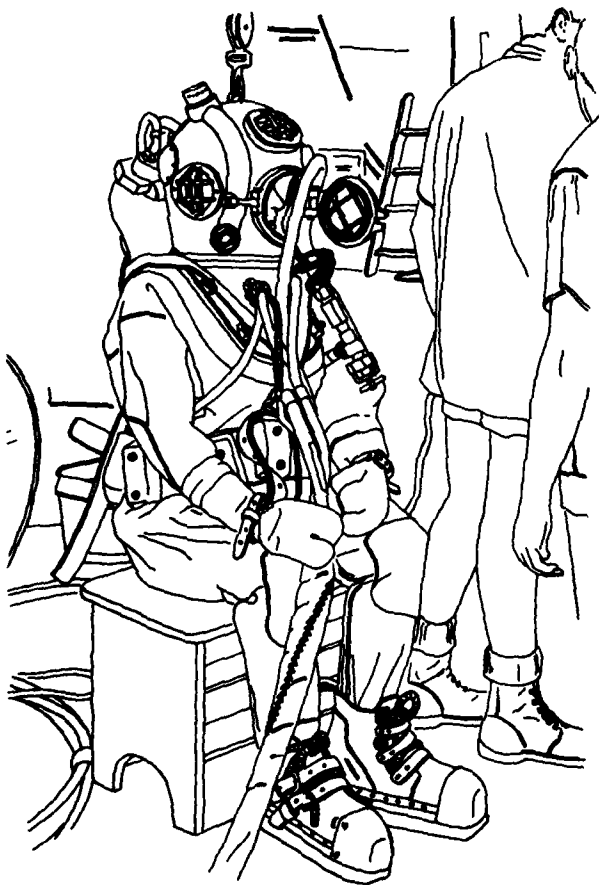

Minimum Equipment—

- Recirculating helmet and breastplate
- Diving dress
- Thermal underwear
- Weight belt
- Weighted shoes (heavy)
- Knife
- Gloves
- Surface umbilical
- Pneumofathometer



Figure 10-2 Recirculating Deep-Sea Diving — MK 5

Principal Applications—

- Deep diving operations
- Submarine Rescue
- Heavy salvage and repair
- Underwater construction

Advantages—

- Unlimited by gas supply
- Maximum physical and thermal protection
- Voice and line-pull communications
- Variable buoyancy

Disadvantages—

- Slow deployment
- Poor mobility
- Large support craft and surface crew

Restrictions—

- Work limits—
 - Normal 300 feet
 - Maximum 380 feet
- Current—2.5 knots maximum
- Diving team—minimum 10 men

Operational Considerations—

- Adequate mixed-gas supply
- Stand-by diver required
- Diving medical officer required for dives deeper than 300 feet
- Recompression chamber required
- Exceptional exposures require approval of commanding officer or higher authority

RECIRCULATING DEEP-SEA DIVING GENERAL CHARACTERISTICS — MK 12

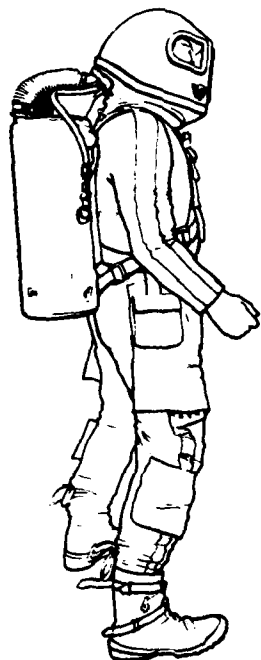

Minimum Equipment—

- Helmet assembly
- Lower breach ring
- Drysuit (standard or hot water)
- Outer garment
- Jocking harness
- Leg, thigh and hip weights
- Boots
- Recirculator assembly
- Gloves
- Surface umbilical
- Pneumofathometer
- Knife

Principal Applications—

- Deep diving operations
- Submarine rescue
- Heavy salvage and repair
- Underwater constructions

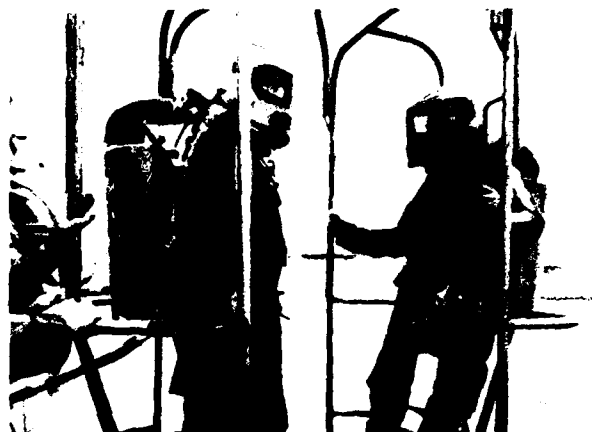

Figure 10-3 Recirculating Deep-Sea Diving — MK 12

Advantages—

- Unlimited by gas supply
- Maximum physical and thermal protection
- Voice-line pull communications
- High degree of mobility
- Variable buoyancy

Disadvantages—

- Large support craft and surface crew

Restrictions—

- Work limits—
 - Normal 300 feet
 - Maximum 380 feet
- Current—2.5 knots maximum
- Diving team—10 men

Operational Considerations—

- Adequate mixed-gas supply
- Stand-by diver required
- Diving medical officer required for dives deeper than 300 feet
- Recompression chamber required
- Exceptional exposures require approval of commanding officer or higher authority
- Hot water heated outer garment and canister for water temperatures below 50°F.

LIGHTWEIGHT MIXED-GAS DIVING GENERAL CHARACTERISTICS



Figure 10-4 Divers Mask USN MK 1 MOD S

Minimum Equipment—

- Diver's Mask USN MK 1
- Thermal protection garment
- Weight belt
- Knife
- Swim fins or shoes
- Open bell with surface umbilical
- Umbilical from open bell
- Come-home bottle
- Harness and jock

Principal Applications—

- Deep water search, inspection and repair
- Light salvage

Advantages—

- Unlimited by gas supply
- Good horizontal mobility
- Voice and line-pull communications
- Fast deployment
- Protection of open bell during descent and ascent
- Safety provided by open bell at worksite

Disadvantages—

- Mobility limited by umbilical
- Support craft required
- Limited physical protection when working outside of bell

Restrictions—

- Work limits—
 - Normal 300 feet
 - Maximum 380 feet
- Current—2.5 knots maximum
- Diving team—minimum 10 men

Operational Considerations—

- Open bell required
- Adequate mixed-gas supply
- Stand-by diver required
- Diving medical officer required for dives deeper than 300 feet
- Recompression chamber required
- Exceptional exposures require approval of commanding officer or other authority

MK 6 UBA SEMICLOSED-CIRCUIT DIVING GENERAL CHARACTERISTICS

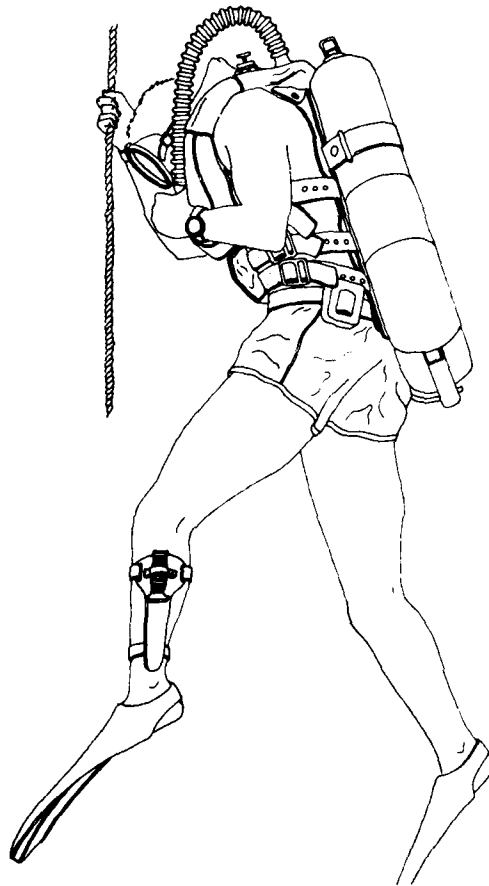

Minimum Equipment—

MK 3 yoke-type life preserver
Belt and knife
Swim fins
Facemask
Wristwatch

Principal Applications—

Deep search and inspection
Light repair and recovery
Clandestine operations

OPERATIONS PLANNING



Figure 10-5 MK 6 SCUBA

Advantages—

Efficient utilization of mixed-gas supply
Reduced surface bubbles
Rapid deployment
Portability
Excellent mobility
Minimum support
Minimum bottom disturbances

Disadvantages—

Limited endurance
Breathing resistance
Limited physical and thermal protection
Lack of voice communications
Influenced by current

Restrictions—

Work limits—Helium-Oxygen—
Normal 180 feet
Maximum 200 feet
Work limits—Nitrogen-Oxygen—
Normal 130 feet
Maximum 170 feet
Current—1 knot maximum
Diving team
One diver—minimum 4 men
Two divers—fleet minimum 6 men
EOD/UDT/SEAL minimum 4 men

Operational Considerations—

Buddy and standby diver required*
Diving medical officer required for diver deeper than normal working limit.
Recompression chamber required for dives deeper than 170 feet**
Small boat required for diver recovery
Avoid use in areas of coral and jagged rock
Moderate to good visibility preferred

*Requirement may be waived by UDT/SEAL diving officer

**Requirement may be waived by EOD/UDT/SEAL diving officer

**CLOSED-CIRCUIT DIVING
GENERAL CHARACTERISTICS — MK 15
UBA**

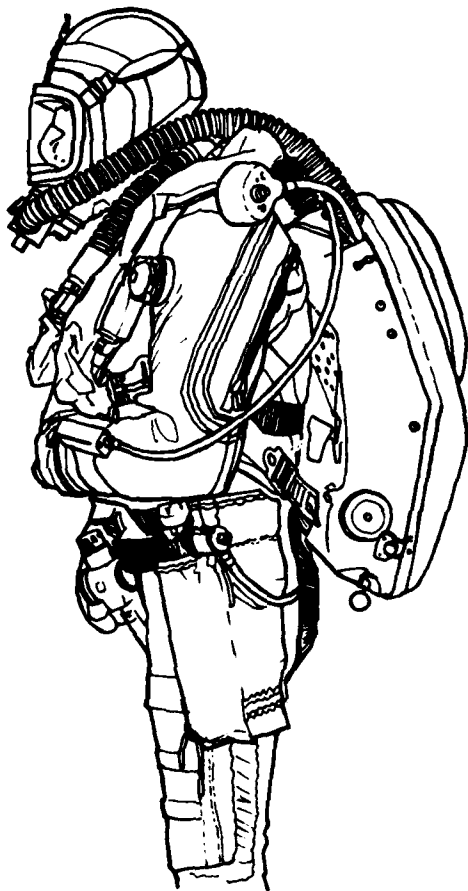

Minimum Equipment—

- Life preserver
- Belt and knife
- Emergency flange
- Swim fins
- Facemask or FFM
- Weight belt
- Wristwatch

Principal Applications—

- Deep search and inspection
- Light repair and recovery
- Clandestine operations



Figure 10-6 MK 15 SCUBA

Advantages—

- Minimal offgassing
- Optimum efficiency of gas supply
- Portability
- Excellent mobility
- Communications (when used with FFM)
- Modularized assembly

Disadvantages—

- Extended decompression requirement for deep dives
- Limited physical and thermal protection

Restrictions—

- Depth limit 150 feet, air diluent
- Repetitive decompression dives may not be conducted without Underwater Decompression Computer (UDC)

Operational Considerations—

- Diving Team
 - One diver—on scene support to include dive supervisor, standby diver and tender
 - Two or more divers—tender not required, buddy system to be used
- One safety boat required for daylight operations
- Two safety boats required for night operations
- Communications required between all support craft
- If UDC not used divers must carry their appropriate decompression schedule

DEEP DIVING SYSTEMS GENERAL CHARACTERISTICS

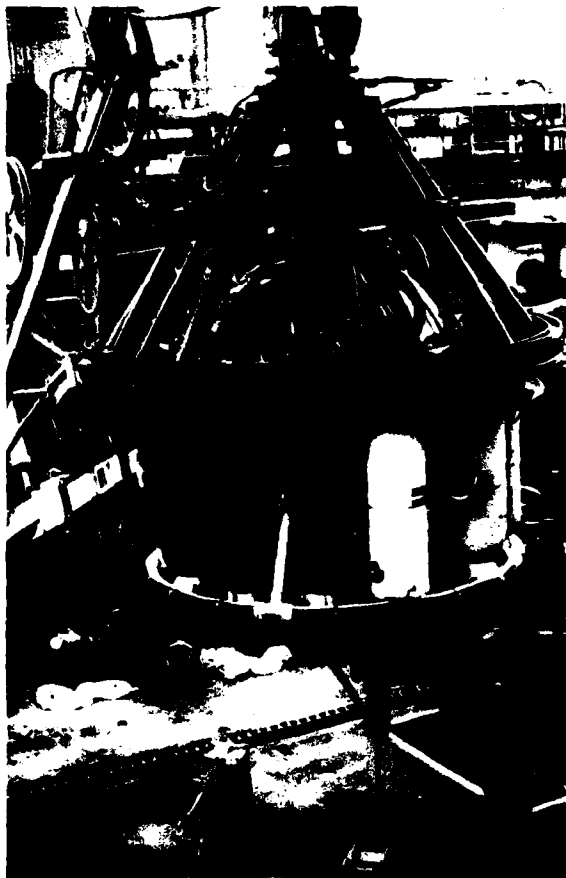

DDS MK 2 MOD 0

Minimum Equipment—

As specified by the system being used,
but to include—

- Deck decompression chamber
- Entrance lock
- Personnel transfer capsule
- Control console
- Life support system
- Handling system
- Diver's lockout apparatus, either—
 - Diver's Mask USN MK 1 MOD 0/S
 - MK II MOD 0

Principal Applications—

- Deep observation
- Deep, search, salvage and repair
- Saturation diving for projects requiring extensive bottom time

Advantages—

- Maximum diver safety
- Efficient utilization of bottom time
- Maximum comfort
- Continuous personnel monitoring

Disadvantages—

- Slow deployment non-pressurized pre-dive inspections
- Large support craft and crew
- Limited mobility

Restrictions—

- Work limits—
 - DDS MK 2 MOD 0—850 feet
 - DDS MK 2 MOD 1—850 feet
 - MK 11 MOD 0—650 feet
 - MK 1 MOD S Mask—1000 feet
- Diving team—
 - DDS MK 2—16-17*

Operational Considerations—

- Large gas supply required
- Stand-by diver(s) needed for each diver out of PTC
- All diving personnel must be saturation qualified
- Diving medical officer required
- Operationally limited by the capability of the handling system
- Supply of hot water required for cold water lock-outs
- Selection of diver's apparatus governed by lock-out depth and duration

*plus handling crew and based on single watch, saturation-mode

SELECT AND ASSEMBLE THE DIVING TEAM 10.5

The typical mixed-gas team of conventional surface-supported, mixed-gas divers and deep-dive system divers is composed of personnel as set forth in Tables 10-2 and 10-3.

BRIEF THE DIVING TEAM 10.6

With the larger teams and increased complexities of mixed-gas operations, comprehensive briefings of all hands are extremely important. While the operation is in progress, divers returning to the surface (or to the PTC or habitat) should be promptly de-briefed so that topside personnel can be kept advised on the progress of the work and will have the information necessary for making modifications to the dive plan when appropriate.

EXTERNAL EAR PROPHYLAXIS 10.7

External ear prophylaxis should be provided to diving personnel to prevent ear infections. External otitis can be prevented by use of 2% acetic acid in aluminum acetate solution each morning, evening, and following each wet dive. The head is tilted to one side and the canal gently filled with the solution. The solution must remain in the ear canal for 5 minutes. The head is then tilted to the other side to allow the solution to run out. The procedure is repeated in the other ear. The five-minute duration that the solution remains in each ear is critical to the success of the prophylaxis. The dive supervisor should observe and time ear prophylaxis when diving in water where external otitis is known to be a problem.

GAS SUPPLY 10.8

In air diving the breathing mixture is readily available, although operational limitations may be imposed by the capacities of pumps and compressors or the availability of back-up systems. In mixed-gas diving there is the one obvious prior requirement: adequate quantities of the appropriate gases must have been ordered and placed in stock before the operation may begin.

This is obviously a basic requirement. Perhaps too basic, because some otherwise well-planned operations have been failures because the support units had left port for remote operations carrying the wrong gas mixtures. In part these problems arise from the fact that many diving units are not equipped to work with "pure" gases and must use pre-mixed standard percentages—for instance, 16% oxygen and 84% helium or 20% oxygen and 80% helium. The gas mixture must be correct for each planned dive (based upon depth and apparatus to be used)—and must be determined far enough in advance of the operation to permit orderly procurement. If the operation is to be conducted in some area remote from the nearest point of re-supply, the initial determinations are critical.

Additionally, the gas supply must be adequate—in both quantity and content—for all phases of the operation from descent to decompression, and it must include a substantial reserve.

The procedures for determining the gas and CO₂ absorbent requirements of various types of breathing apparatus are shown in Table 10-3. The gas storage volume of various apparatus is shown in Table No. 10-4. When DDS-type of equipment is to be employed, additional substantial quantities of gas must be included for DDC and PTC charging and for replacing losses due to leakage, transfer trunk and service lock usage and scrubber cycling. Required standards or purity, methods of gas analysis, and mixing procedures will be found in Appendix No. C.

ASR HE-O₂ Supply System 10.8.1 Although the use of mixed gas is not restricted to diving from submarine-rescue vessels, ASR's do constitute the largest category of suitably equipped ships in the USN fleet. Even though the precise design of gas supplies aboard other vessels may vary from that aboard the ASR, the principles of other systems should be analogous. Consequently, the functioning of the ASR system is discussed in detail. It should be noted, however, that all members of the diving team assigned to a ship or unit equipped to conduct mixed-gas operations should be completely familiar with the specific system being used and the operation of automatic gas mixers, if installed.

TABLE 10-2—PERSONNEL REQUIREMENT CHART

DESIGNATION	MIXED-GAS SCUBA Surface Crew			
	Optimum		Minimum	
	One Diver	Two Divers	One Diver	Two Divers (D)
Diving Officer	(C)	(C)	(C)	(C)
Diving Supervisor	1	1	1	1
Diver	1	2	1	2
Standby Diver	1	1	1	1
Tender	1	2(A)	1(A,B)	2(A,B)
Timekeeper/Recorder	1	1		
Total Men Required	5	7	4	6

DESIGNATION	SURFACE-SUPPLIED MIXED-GAS		
	Deep-Sea Recirculating Rig		Lightweight (MK 1) & Open Bell
	One Diver	Two Divers	
Diving Officer	1	1	1
Diving Medical Officer (F)	1	1	1
Diving Supervisor	1	1	1
Diver	1	2	1
Standby Diver	1	1	1
Tender	3	4	2
Timekeeper/Recorder	1	1	1
Rack Operator	1	1	1
Winch/Tugger Operator			1(E)
Total Men Required	10	12	10

NOTES:

- A. One Tender/Diver required when Divers are surface tended; if using Buddy System one Tender required each Buddy pair.
- B. Tender also acts as Timekeeper.
- C. EOD Diving Officer required on scene for all EOD operations.
- D. Four-man EOD team authorized to use two Divers.

- E. Ascent/Descent control of open bell.
- F. A Diving Medical Officer is required for all dives exceeding the normal working limit or operational depth limit as listed in the Operational Depth Limits for Diving Procedures Table 10-1

TABLE 10-2—PERSONNEL REQUIREMENT CHART (CONTINUED)**DEEP DIVING SYSTEM DDS MK 2**

WATCH STATION	NOBC/NEC
Diving Officer	9315, 5346
Diving Medical Officer	0090
Diving Supervisor	5346, 5311
Atmosphere Monitor	5346, 5311, 8493
MCC Gas Control Operator	5311, 5342, 8493
Life Support Operator	5311, 5342, 8493
MCC Communication and Log Operator	5311, 5342, 8493, 5343
Surface Support Divers	5311, 5342, 8493, 5343
Gas King	5346, 5311
PTC Operators	9315, 5346, 5311, 8493
PTC Divers	9315, 5346, 5311, 8493
Main Deck Supervisor	5346, 5311

Total Men Required:

16

The NEC's listed are the minimum level qualification allowed. The surface support divers must be qualified in the diving technique being used. NOBC 9315 and NEC 5346 can stand any watch for which qualified except diving medical officer. Manning is shown for use of one DDC only. Additional handling crew for PTC is required from ships personnel but not herein shown.

The ASR helium-oxygen system consists of a helium-oxygen and oxygen cylinder stowage rack; diving station supply manifolds; and associated volume tanks, valves, gages, and piping as shown in Figure No. 10-7. The system is designed so that one of three breathing media—helium-oxygen, oxygen, or compressed air—can be supplied to the diver as required. The installations in different submarine-rescue vessels vary in detail of design, but in general they all provide for stowage of approximately 100 gas cylinders and for diving 2 divers from each of 2 separate stations.

The cylinders containing the helium-oxygen and oxygen gases are arranged in banks (Figure No. 10-8). They are arranged so that each helium-oxygen bank is loaded with a mixture containing a definite percentage of oxygen. The cylinder valves are opened, and gas to be supplied to the diver can then be controlled by valves on each bank. The oxygen cylinders are arranged in their own banks. The stowage is so designed that cylinders in an exhausted bank can be replaced without interrupting gas supply to the diver.

Helium-oxygen from the cylinder stowage rack passes through a high-pressure strainer and, in the installation shown in Figure 10-9 and Figure No. 10-10, through a pressure regulator to the volume tanks. These volume tanks number two for helium-oxygen and one or two for oxygen. Oxygen from the cylinder stowage rack passes through the oxygen pressure regulator before entering its volume tank(s). These piping systems include suitable valves, gages, and bypass arrangements.

Gas from the volume tanks then goes to the diving stations where pressure-regulating valves for controlling the pressure of helium-oxygen or oxygen supplied to the divers are located (Figure No. 10-11). Each of these diving station manifolds provides necessary piping, valves, and gages to supply either helium-oxygen, oxygen, or air to one or two divers. It should be remembered that pressure regulation of the compressed air is at the source and not at the manifold.

The pressure-regulating valves (Figure No's 10-10A and 10-10B) with their dome loaders are used to

TABLE 10-3—AVERAGE MIXED-GAS BREATHING APPARATUS GAS CONSUMPTION RATES AND CO₂ ABSORBENT USAGE

EQUIPMENT	GAS CONSUMPTION RATES*		
	DEMAND		RECIRCULATING
	Light Work	Heavy Work	Heavy Work Swimming
Diver's Mask USN MK 1	0.76 acfm 20.0 lpm	1.53 acfm 40.0 lpm	NA
Deep-Sea Recirculating Helmet	NA	NA	0.5 scfm 13.3 lpm
MK 6 & MK 11 60% O ₂ , 40% N ₂	NA	NA	0.28 scfm 6.9 lpm
40% O ₂ , 60% N ₂	NA	NA	0.42 scfm 11.0 lpm
32.5% O ₂ , 67.5% N ₂	NA	NA	0.74 scfm 19.5 lpm
32% O ₂ , 68% He	NA	NA	0.65 scfm 17.1 lpm
40% O ₂ , 60% He	NA	NA	0.39 scfm 10.5 lpm
Emerson Rebreather	NA	NA	0.053 scfm 1.4 lpm

*scfm is standard cubic feet, 70°F
lpm is liters, STPD 32°F

**CO₂ ABSORBENT USAGE AT DEPTH LIMIT
~ DURATION (HOURS)**

EQUIPMENT	CO ₂ ABSORBENT CAPACITY (approximate, lb.)	Seawater Temperature	
		40° F	70° F
MK 1	NA	NA	NA
MK 5	6	0.34	2.7
MK 12	12	9	9
MK 6	6	0.34	2.7
MK 11	7.5	1.5	4.6
MK 15	7.5	2.7	6
Emerson Rebreather	6	0.34	2.7

TABLE 10-4—CAPACITY OF MIXED-GAS APPARATUS CYLINDERS

EQUIPMENT	Rated Pressure PSIG	Water Volume Cubic Inches	Gas Capacity		Recommended Minimum Reserve Pressure PSIG	Gas Content
			Surface Feet ³	Volume Liters		
Close d-Circuit O ₂ (EMERSON)	2000	152	12.7	360	500	O ₂
MK 6 Semiclosed-Circuit	3000	725	77	2380	600	He-O ₂
MK 11 Semiclosed-Circuit (2 Cylinders)	3000	330	35	991	2700	He-O ₂
MK 15 Diluent	3000	177	21	595	No Reserve	
MK 15 Oxygen	3000	177	21	595	Reserve	

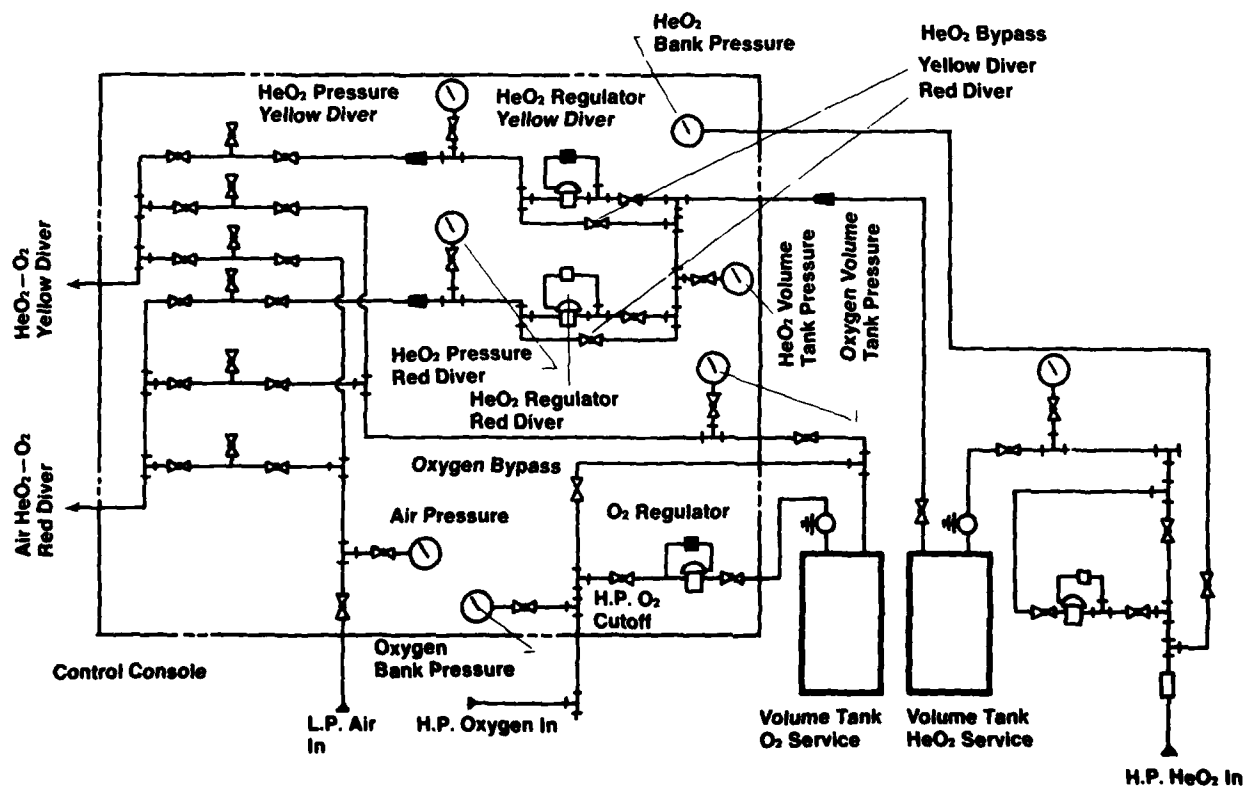

Figure 10-7 ASR Gas Supply Schematic

regulate the pressure of helium-oxygen gas mixtures to that required by the diver. The valves are similar in construction to other diaphragm-operated regulators except that, instead of controlling the discharge pressure by means of spring pressure against the diaphragm, a dome over the diaphragm is charged to a suitable pressure by the dome loader. In case the pressure regulator does not operate correctly it can be cut out of the system by cutout valves and the pressure controlled by means of a bypass valve. The pressure delivered by the regulator must be carefully adjusted to the correct over-bottom pressure for the diver. This adjustment requires continuous changing of the dome loader setting while the diver is going down or coming up. The most likely causes of derangement of the regulator are failure of the diaphragm and worn or damaged valve parts.

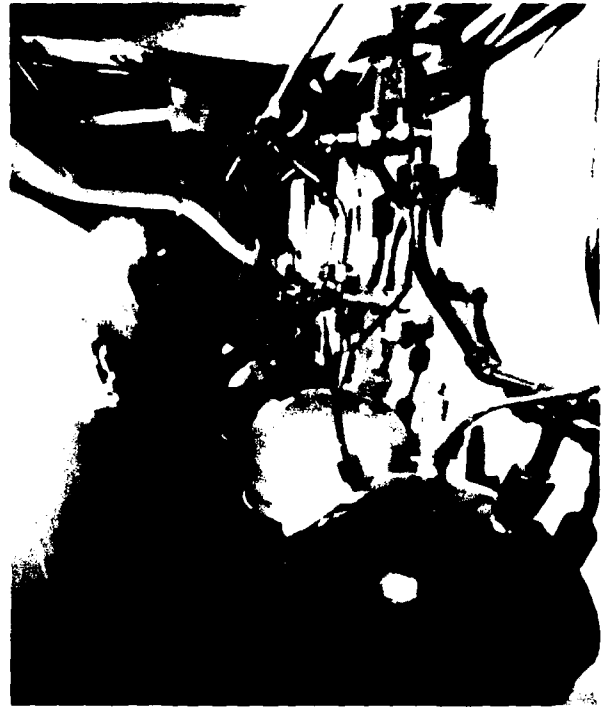

Figure 10-9 He-O₂ and O₂ Volume Tanks.



Figure 10-8 ASR Gas Banks.

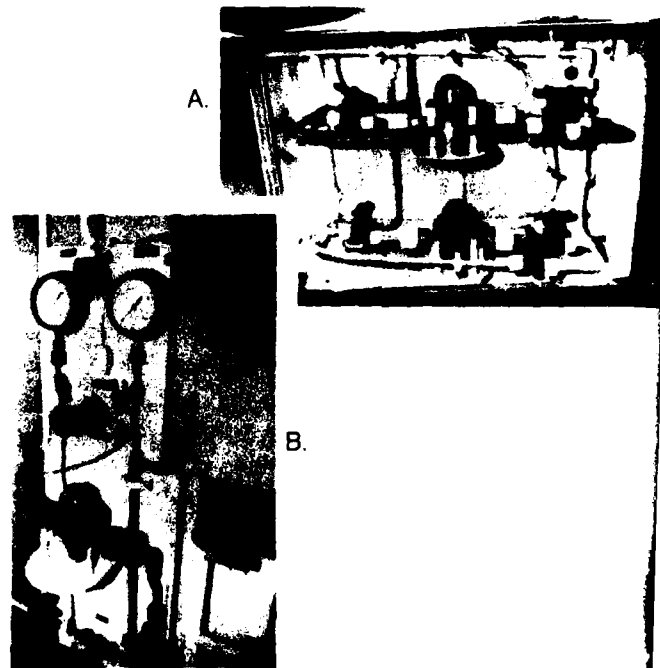

Figure 10-10 He-O₂ high pressure regulating station

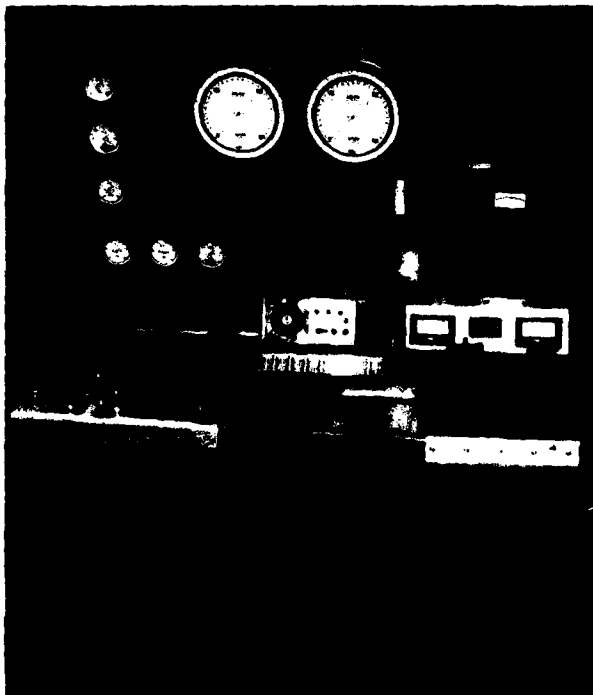

Figure 10-11 Diving station manifold—ATS-1 class console

HYPERBARIC FLAMMABILITY 10.9

Recompression and deck decompression chambers (for saturation diving) are routinely used in support of mixed-gas diving. Because extensive oxygen breathing by mask in surface chambers is common practice, and in saturation procedures it is possible to vary the chamber oxygen content, the hazard of chamber fire assumes significant proportions.

It is often difficult or impossible to remove with absolute certainty any of the three conditions that can result in a fire from a closed-chamber atmosphere. For this reason operating personnel must be aware of the hazards and potential sources of chamber fires. The conditions necessary for a fire include: (1) an atmosphere capable of supporting combustion, (2) a source of ignition, and (3) a fuel. Every effort must be made to reduce or eliminate all materials and equipment from the chamber atmosphere which could contribute to a fire under pressure.

The percentage of oxygen in the atmosphere primarily determines the extent to which a given atmosphere will support combustion. Studies of oxygen-nitrogen mixtures have shown that many materials that would not burn in an atmosphere containing 21 percent oxygen will ignite and burn readily in an atmosphere containing 31 percent oxygen. In addition, it has been determined that at a higher total pressure ignition of certain materials will occur where no ignition was possible at lower pressures. Substitution of helium for nitrogen in the atmosphere reduces the tendency for ignition, but once ignited, materials burn at a faster rate.

Generally, the oxygen concentration in the chamber atmosphere for deep dives is maintained at low levels to avoid oxygen toxicity. This decrease in the oxygen percentage may also render the atmosphere incapable of supporting combustion under certain carefully defined conditions. Four zones representing complete combustion, incomplete combustion, slight combustion and no combustion are shown in Figure No. 10-12. From this figure it is possible to compute the depth at which combustion will be supported for a given oxygen content in the environment. Figure 10-12 compares the oxygen partial pressure (ppO₂) with the depth (FSW) showing the "fire zone" which is

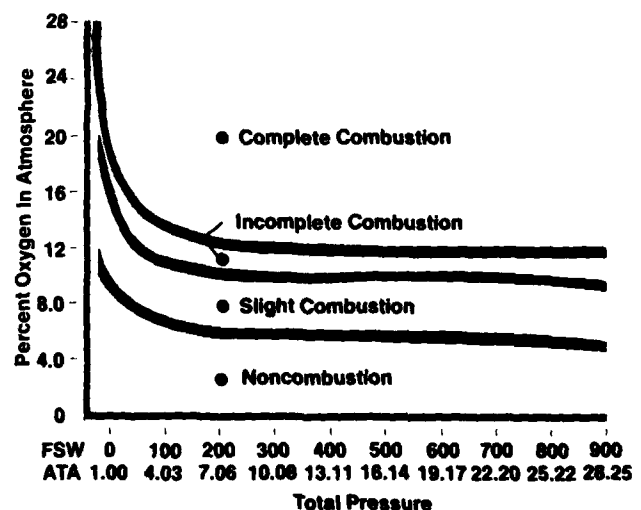

Figure 10-12 Hyperbaric Flammability

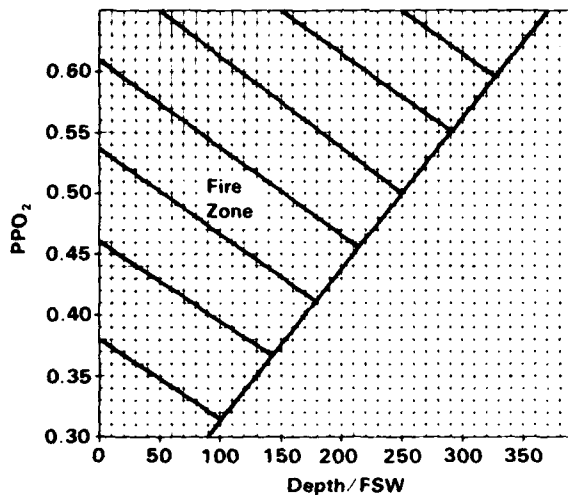

Figure 10-13 Fire Zone Chart

defined to exist in the range of oxygen content above the zone of noncombustion in Figure 10-12. It should be noted that for chamber operation where the ppO_2 is maintained at .4 ATM, the "fire zone" will range from the surface to 170 FSW. When a different concentration of oxygen exists in the chamber, Figure 10-13 should be consulted to determine the appropriate depth of the "fire zone."

As a safety precaution, the oxygen partial pressure and absolute concentration within the chamber should be held to an absolute minimum consistent with the physiological requirements of the occupants. The quantity of flammable materials and potential ignition sources must also be kept to an absolute minimum within the chamber.

CHAMBER ATMOSPHERE CONTAMINATION 10.10

The residence time which mixed-gas divers may spend in surface chambers can be extensive, particularly in saturation operations. With increased exposure time to the chamber atmosphere, the possible hazards to health presented by minor quantities of toxic impurities in the environment increases.

Toxic or noxious contaminants can be introduced into a chamber atmosphere in many obvious and often insidious ways. Items including paint, mastic, glue, cleaning solvents, wiring insulation, and rubber and plastic coatings can emit gaseous components which may cause injury to occupants in a high-pressure, closed atmosphere. Other sources of contaminants that could cause discomfort to chamber occupants include the diver himself, the diver's waste materials, machinery or equipment failures. The toxic effects and limits of most contaminants have not been established for high pressure atmospheres. Contaminant limits are available for submarines based on a 1-atmosphere environment. However, great care should be taken before interpreting these limits for use in high pressure chamber atmospheres. Factors which must be taken into consideration in determining if a hazardous condition exists include—concentration of a contaminant, whether the effects are cumulative, the frequency with which contamination occurs, and the duration of such periods.

The capability for removal of gaseous contaminants in high pressure chambers or capsules of DDS systems is limited.

CHAPTER ELEVEN

MIXED-GAS UNDERWATER BREATHING APPARATUS

Mixed-gas underwater breathing apparatus (UBA) encompasses that group of diver breathing equipment which employs a lightweight, diver-worn gas recirculation system to remove carbon dioxide and either an integral or PTC-provided mixed-gas supply. This class of equipment provides the operational mobility of the free or lightweight-equipped diver with the depth advantages of mixed gas and the extension of underwater duration and/or gas supply inherent in recirculating the diver's breathing gas. Some UBA's permit completely autonomous diver operations and therefore can be referred to as mixed-gas SCUBA; other apparatus of similar type receive their primary gas supply (via umbilical) from a PTC and consequently are not true SCUBA. Both types of equipment are grouped together in this chapter under the "UBA" designation because of their similarities in construction, operation, and use.

Although the world-wide development of mixed-gas UBA dates from 1912, its use in the USN is quite recent. Following WWII the MK 5 SCUBA was developed to provide greater depth capability, underwater duration, and minimum bubble and sound production for combat swimmers and Explosive Ordnance Disposal divers. The MK 5 is the direct ancestor of the current MK 6 apparatus which is widely used in free swimmer applications by UDT, SEAL and EOD divers.

In the 1960's, increased depth and duration capabilities provided by the introduction of deep diving systems (DDS) and saturation diving techniques brought about the need for improved diver breathing apparatus. The current generation of UBA for PTC diving operation, developed to meet these increased demands, share a common technology with mixed-gas SCUBA and oxygen rebreathers (Chapter Fourteen). The basic difference lies in the required umbilical to the PTC. The diver tether (essential to safe operations in DDS diving), while somewhat limiting diver mobility, provides several advantages to the PTC diver not afforded the free mixed-gas SCUBA swimmer. The umbilical can provide hard-wire two-way voice communications, heat to make up for respiratory and body surface losses, and a gas supply which is not limited to that which can be carried by the diver.



Figure 11-1 U.S. Navy Diving Team wearing the Mark 15 UBA

In modern diving there is no wider group of equipment than that of the UBA. Numerous manufacturers have made and are currently producing a great variety of mixed-gas recirculating apparatus for the underwater swimmer in both tethered and untethered modes. Many models can be used in either mode.

Although the number of types and specific features of UBA are extensive, the majority employ one of two types of operating principles—semiclosed-circuit or closed-circuit. It is the intent of this chapter to explain the nature of these two fundamental systems and describe in detail the specific UBA currently in USN service.

PRINCIPLES OF OPERATIONS 11.1

With open-circuit SCUBA, diving depth and duration are sharply restricted by the low efficiency of gas utilization resulting from complete discharge of each exhalation. The efficiency of gas utilization, with open-circuit apparatus based upon consumption of available oxygen, is approximately 5 per cent near the surface and decreases with increasing depth. In order

to conserve the gas supply and extend underwater duration, it is essential to improve the efficiency of gas utilization. This is accomplished in the UBA by diver-worn systems which recirculate the diver's breathing medium for reuse, remove carbon dioxide produced by metabolic action in the body, and control the oxygen concentration in the inspired gas within physiologically safe limits.

Recirculation and CO₂ Removal 11.1.1 The diver's breathing medium is recirculated in the UBA to remove carbon dioxide from the gas stream and permit reuse of the inert diluent component of the mixture. The basic recirculation system, as shown in Figure No. 11-2, consists of a closed loop incorporating inhalation and exhalation hoses and associated check valves; a mouthpiece, full facemask, or lightweight helmet; a carbon dioxide removal unit; and one or two breathing bags.

Movement of recirculating gas through the circuit is normally accomplished by the natural inhalation-exhalation action of the diver's lungs. Since the lungs are only capable of producing small pressure differences, the entire circuit must be designed for minimum flow restriction.

The connection device between the diver's breathing passages and the circuit must be of minimum volume to preclude deadspace and associated rebreathing of local, CO₂-rich gas. This is accomplished in full-face masks and lightweight helmets by using an integral oral-nasal mask or mouthpiece. Similarly, inhalation and exhalation check valves used to ensure unidirectional flow of gas through the circuit must be in close proximity to the diver's breathing passages to minimize deadspace. All connecting hoses in the system must be of relatively large diameter (usually 1½" diameter) to minimize pressure drop.

CARBON DIOXIDE SCRUBBER 11.1.1.1 Carbon dioxide is normally removed from the breathing circuit in a watertight canister of CO₂ absorbent material located in the backpack of the UBA. Certain absorbents, e.g., shell natron (sodium hydroxide) and lithium hydroxide, strongly react with water to produce caustic fumes and cannot be used in UBA's. The canister assembly is filled with a USN approved absorbent which, if inadvertently wetted, produces a

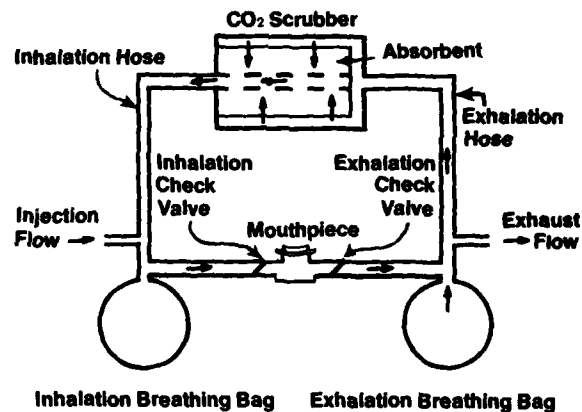

Figure 11-2 Schematic of the basic UBA recirculating loop.

minimum of caustic fumes. Water produced by the reaction between the CO₂ and the CO₂ absorbent and by the diver himself, is sometimes removed by a chemical absorbent or water absorbent material in the canister. CO₂ absorption capacity of the scrubber bed is strongly influenced by temperature. Capacity may be reduced as much as 80% when operating temperature drops for 70°F to 40°F. In UBA's designed for use from PTC's, it is common practice to heat the backpack with hot water to maintain permissible inspired gas temperatures and to improve canister duration in cold water operations.

The canister design must provide low flow resistance and maximum contact between the gas and the absorbent. Flow resistance is usually minimized by employing a canister housing which provides annual space around the absorbent bed to reduce the gas flow distance. The absorbent may be provided in a throw-away cartridge or be bulk-filled into a canister. If improperly bulk-filled, channels may be formed in

the bed by bridging of the absorbent granules which permit gas to bypass the absorbent and retain carbon dioxide. As a consequence, care must be taken during bulk filling operations to thoroughly settle the bed by gentle tapping of the canister. Fine material which passes through the canister screen must be blown free from the system before use to avoid dust inhalation.

BREATHING BAGS 11.1.1.2 One or two breathing bags are used in all UBA to permit free breathing in the circuit. The need for such devices can be readily demonstrated by attempting to exhale and inhale into an empty soda pop bottle. The bottle, analogous to the recirculation system without bags, is unyielding and presents extreme back pressure. In order to compensate for this phenomenon, extensible gas accumulators or reservoirs must be placed in the UBA circuit. A flexible diaphragm or breathing bag(s) is located in parallel or series in the breathing circuit and has a maximum displacement equal to the combined volume of both lungs.

Neutral buoyancy is inherent in the system since the gas reservoir is designed to act counter to normal lung action (sometimes such bags are referred to as "counter lungs"), and consequently, constant volume is maintained. During exhalation, and associated reduction in body displacement and buoyancy due to diminished lung volume, the reservoir expands and displaces an equal water volume to maintain neutral diver buoyancy. On inhalation the situation is reversed. This cycle is shown in (Figure No. 11-3).

The flexible gas reservoir must be physically located as close to the diver's lungs as possible to minimize any hydrostatic pressure difference between the lungs and the reservoir as the diver changes attitude in the water. This is accomplished in twin-bag UBA's by locating the bags on the upper portion of the body trunk to the left and right of the head either in the front attached to a vest or in the rear within the backpack.

Single bag UBA's usually have the reservoir built into the backpack assembly and located at the centroid of the lungs.

The use of a single bag or diaphragm located within the backpack is mechanically simpler and affords

minimum encumbrance to the diver and maximum protection for the reservoir. However, because of the variation in flowrate experienced during each breathing cycle, greater breathing resistance is encountered during peak flow in the single bag system than in a two-bag system. The twin-bag UBA permits gas to be accumulated on both sides of the scrubber and tends to average the flowrate through the system to minimize pressure drop.

RECIRCULATION SYSTEM FAILURE 11.1.1.3 Reliable functioning of the recirculation system is vital to the safety of the UBA-equipped diver. Any factor which reduces the efficiency of CO₂ removal increases the hazard of carbon dioxide poisoning. Properly maintained equipment filled with fresh, well-packed absorbent; avoidance of partial water flooding due to improper assembly, testing, or technique; and careful attention to limiting underwater duration to safe canister capacity at the operating temperature are all essential to diver safety.

Gas Addition, Exhaust and Monitoring 11.1.2 In addition to the hazard of carbon dioxide poisoning, the UBA diver encounters two additional hazards—hypoxia and oxygen toxicity. For safe operation it is essential that the UBA reliably control the oxygen partial pressure in the breathing medium within narrow limits to avoid these hazards.

Hypoxia can occur whenever sufficient oxygen is not being added to the recirculation circuit to meet metabolic requirements. If oxygen or an oxygen-rich mixed gas is not added to the re-breathing circuit, it is apparent that the oxygen in the loop will be gradually consumed until a point is reached at which the mixture is incapable of sustaining life.

Oxygen toxicity, as described in Chapter Nine, can occur whenever the oxygen partial pressure in the diver's breathing medium exceeds specified concentration and exposure time limits. Consequently, in addition to the proper pre-dive selection of the correct oxygen partial pressure for the depth and duration of the dive, the UBA must function to limit the maximum oxygen level to the required value at the anticipated work rate.

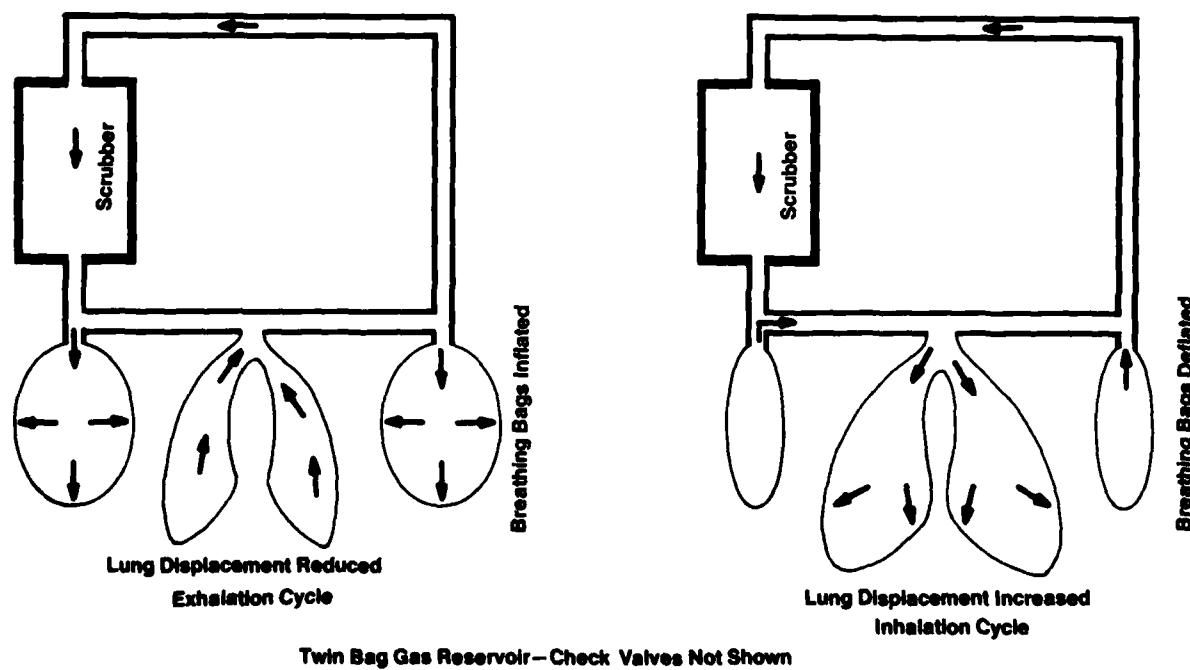
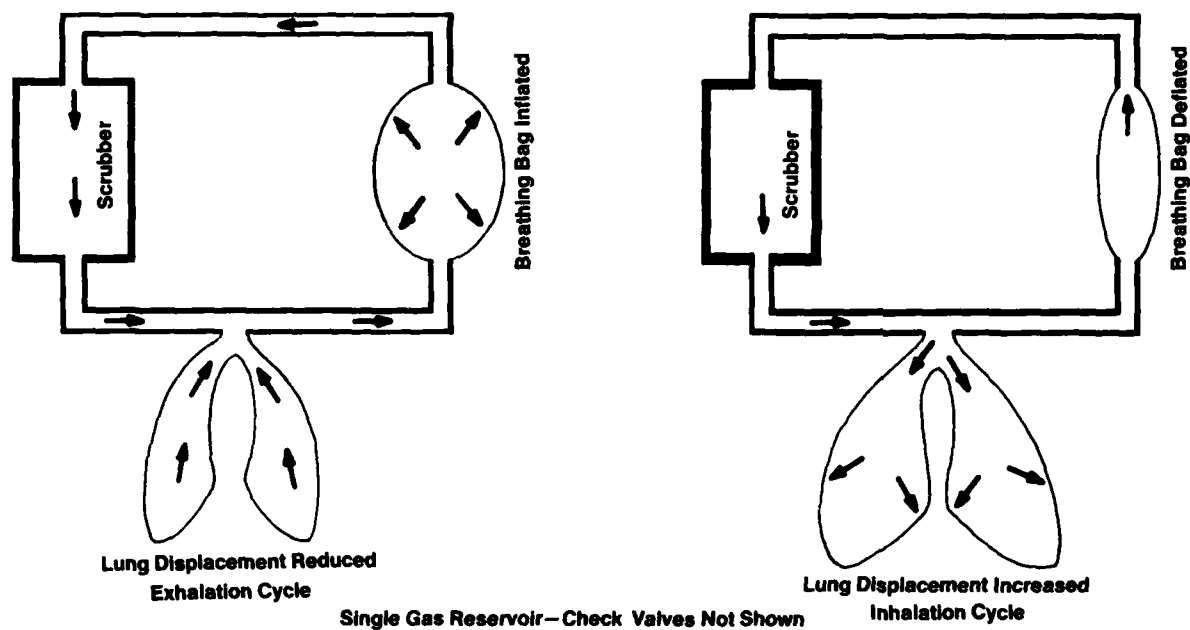

Figure 11-3 UBA breathing bags act to maintain the diver's neutral buoyancy by responding counter to lung displacement.

The method used to maintain the oxygen concentration in the breathing medium within the required upper and lower limits in the UBA varies depending upon the principles of operation—semiclosed-circuit or closed-circuit.

SEMICLOSED-CIRCUIT 11.1.2.1 The semiclosed-circuit apparatus employs the continuous injection of a small fixed flowrate of oxygen-rich mixed gas into the system to satisfy metabolic requirements. The oxygen-rich injection gas is mixed with the recirculating mixed gas in the UBA on the inhalation side of the apparatus to maintain the average oxygen partial pressure in the circulating gas stream at the required level. Assuming constant depth operation, a somewhat lesser flowrate (due to oxygen consumption) of recirculating gas from the exhalation side of the apparatus is exhausted to the surrounding water.

The semiclosed UBA employs a **constant mass flow-rate system**. Since oxygen consumption by the body at any given work rate is a mass (not volume) related function, continuous injection of a sufficient mass of oxygen to just balance the body's requirements results in maintenance of a constant partial pressure of oxygen in the recirculating gas stream at any given depth. Constant mass injection of an oxygen-rich (relative to the recirculating stream composition) mixed gas is employed, rather than injection of 100% oxygen, to minimize apparatus complexity. For adequate diver safety under operating conditions involving various work rates and depths, UBAs employing pure oxygen injection require redundant oxygen analysis and control circuits. Such systems are discussed in Section 11.1.2.2. Constant mass injection systems also eliminate the need for automatic or manual variation in volume flow as depth varies throughout the dive.

A. LIMITATIONS—Since semiclosed UBAs use a preset mass flow principle, they are subject to certain operational limitations. The **bag oxygen percentage**, or "bag level," (average O_2 level in the system) must be predetermined based upon the anticipated work rate of the diver and maximum allowable oxygen partial pressure at depth. These considerations establish the flowrate setting and oxygen percentage in the supply mix. The O_2 percentage in the mix is governed

by the maximum partial pressure at depth that may be safely breathed if the recirculation system must be bypassed and supply gas used for direct breathing. Flowrate setting is based upon the percentage of oxygen in the supply mix and the anticipated work rate or oxygen utilization rate of the diver.

The preset conditions result in limits which cannot be altered during the dive if the underwater situation changes. As an example, depth cannot be increased without danger of oxygen toxicity resulting from use of the premixed gas at higher pressure. A UBA flowrate set for minimum exertion and noise propagation level in defusing a mine may be insufficient for an extended swim and produce hypoxia due to over consumption of available oxygen.

The depth range over which a semiclosed UBA can be employed is also limited by injection gas considerations. A free diver deploying from the surface must have a minimum bag oxygen level of 16% at 1.0 atmosphere to avoid hypoxia. Oxygen concentration in the supply mix and flowrate considerations for the surface condition will obviously govern maximum depth due to partial pressure limits.

Semiclosed UBAs adjusted for excursion diving from PTC's at great depth use leaner oxygen supply mixtures and are operationally safe only within a given depth range. An ascent to the surface with a semiclosed apparatus being used from a PTC at 600 feet, even if practical from the standpoint of decompression, would result in hypoxia. Conversely, use of a UBA set for diving from the surface could result in oxygen toxicity if employed from the PTC at 600 feet.

In practice the maximum depth that the highest percentage oxygen mixture can be breathed is the depth at which the partial pressure of oxygen equals 1.6 ata (N_2-O_2 diving) and 2.0 ata ($He-O_2$ diving). As previously discussed, the oxygen percentage of the supply mix must not exceed the allowable oxygen partial pressure limits. The bag oxygen level will always be lower than that of the supply due to metabolic consumption. Maximum oxygen supply percentage or maximum depth on a given supply oxygen level can be determined by solving the following appropriate formula—

$$\%O_2 \text{ max} = \frac{ppO_2 \text{ max} \times 33 \text{ ft/ata} \times 100\%}{D \text{ max} + 33 \text{ ft.}}$$

$$D \text{ max} = \frac{ppO_2 \text{ max} \times 33 \text{ ft/ata} \times 100\%}{\%O_2 \text{ sup}} - 33 \text{ ft}$$

Where—

$\%O_2 \text{ max}$ = Maximum permissible oxygen concentration in supply mixture, percent

$D \text{ max}$ = Maximum depth of dive on available mixture, feet of seawater

$ppO_2 \text{ max}$ = Maximum permissible oxygen partial pressure,
1.6 ata for nitrogen-oxygen mixtures
2.0 ata for helium-oxygen mixtures

$\%O_2 \text{ sup}$ = Maximum permissible oxygen concentration in supply mixture, percent

Example—

Problem—

A. Determine the maximum allowable $\%O_2$ in the supply mixture for a N_2 - O_2 dive to 143 fsw.

B. Determine the maximum allowable dive depth using a supply mixture containing 32% oxygen and 68% helium.

Solution—

Substituting—

A.

$$\%O_2 \text{ max} = \frac{1.6 \text{ ata} \times 33 \text{ ft/ata} \times 100\%}{143 \text{ fsw} + 33 \text{ fsw}} = 30\%$$

B.

$$D \text{ max} = \frac{2.0 \text{ ata} \times 33 \text{ ft/ata} \times 100\%}{32\%} - 33 \text{ fsw}$$

$$= 173 \text{ fsw}$$

For any rate of oxygen utilization by the diver, the bag oxygen percentage can be accurately predicted if the cylinder gas composition and the rate of gas inflow are known. Diver oxygen consumption is normally considered to be 0.5 liters/min at rest and 3.0 liters/min maximum during heavy underwater work. The constant mass flow of gas is usually expressed as liters/min (STPD) because this unit is readily measured during pre-dive adjustment using a variable area flowmeter. The breathing bag (inspired) oxygen and inert gas concentrations during

rest or heavy work can be determined using the following formulas—

$$\%O_2 \text{ bag} = \frac{(O_2 \text{ in} \times G \text{ in}) - O_2 \text{ con}}{G \text{ in} - O_2 \text{ con}} \times 100$$

Where—

$\%O_2 \text{ bag}$ = Bag oxygen level, percent

$O_2 \text{ in}$ = Oxygen level in supply gas, decimal percent

$G \text{ in}$ = Total mixed-gas inflow, liters per minute

$O_2 \text{ con}$ = Oxygen consumed, liters per minute

Example—

Problem—

Determine the bag gas composition for a diver at rest and performing heavy work using a UBA with 60% O_2 /40% N_2 supply mix and an injection gas inflow of 8 liters/min (STPD).

Solution—

Substituting—

$\%O_2 \text{ BAG at Rest}$

$$= 100\% \frac{(.60 \times 8 \text{ liters/min.}) - 0.5 \text{ liters/min.}}{8 \text{ liters/min.} - 0.5 \text{ liters/min.}}$$

$$= 100\% \frac{4.8 \text{ liters/min.} - 0.5 \text{ liters/min.}}{7.5 \text{ liters/min.}}$$

$$= 100\% \frac{4.3 \text{ liters/min.}}{7.5 \text{ liters/min.}} = 57.3\% O_2$$

$\%N_2 \text{ In Bag at Rest} = 100\% - 57.3\% O_2 = 42.7\% N_2$

$\%O_2 \text{ BAG During Work}$

$$= 100\% \frac{(.60 \times 8 \text{ liters/min.}) - 3.0 \text{ liters/min.}}{8 \text{ liters/min.} - 3.0 \text{ liters/min.}}$$

$$= 100\% \frac{4.8 \text{ liters/min.} - 3.0 \text{ liters/min.}}{5.0 \text{ liters/min.}}$$

$$= 100\% \frac{1.8 \text{ liters/min.}}{5.0 \text{ liters/min.}} = 36.0\% O_2$$

$\%N_2 \text{ In Bag During Work} = 100\% - 36\% = 64\% N_2$

From this example it can be seen that the bag oxygen level will vary from 57.3% at rest to 36.0% during heavy activity. During these fluctuations, the gas entering the bag from the supply remains fixed at 8 liters per minute with a 60% O₂/40% N₂ composition.

B. MASS FLOW CONTROL—The constant mass inflow of gas to the recirculation loop of the semiclosed UBA is controlled by an absolute pressure regulator and a preset flow restrictor. The absolute regulator reduces the high pressure supply gas to a **constant delivery pressure regardless of depth**. The restrictor must operate at **critical flow** (sonic velocity) to insure that mass flow into the system will remain constant regardless of diving depth. For a fixed orifice, this condition occurs when the absolute upstream pressure (regulator delivery pressure) to the orifice is more than twice the value of the downstream pressure (dive depth in a UBA). As long as the constant upstream pressure from the regulator exceeds maximum depth pressure by a factor of two, mass flow will remain constant at all shallower depths. If the regulator is improperly set or the orifice improperly sized for the required pressure and flow conditions and the ratio of upstream to downstream pressure becomes less than two, mass flow will change with depth. Some types of restrictors are more efficient than the orifice and can maintain critical flow conditions until the back pressure (dive depth) approaches 75% of the absolute pressure from the regulator.

Examples of mass-flow control systems are shown in Figure No. 11-4. Some semiclosed underwater breathing apparatus, particularly early models, employ a replaceable fixed orifice (available in various sizes) to provide a specific flow with a given gas composition and regulator setting. Other units use a needle valve which can be adjusted and locked for given regulator pressures to provide desired flow. Still others use a venturi nozzle and require no adjustment other than supply pressure because of the venturi's wide flow range. This latter system employs another characteristic of critical flow; namely that critical mass flow through a given flow restrictor is directly proportional to upstream pressure. If the delivery pressure of the regulator is doubled, the mass flow through the restriction will double.

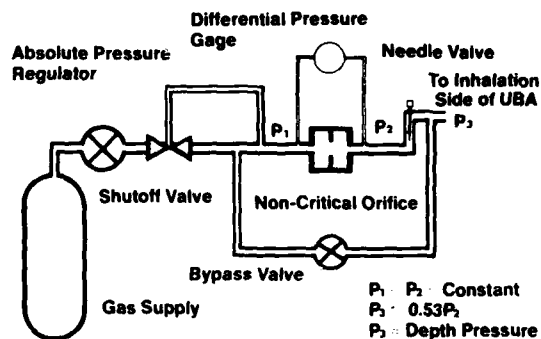

Replaceable Orifice-Needle Valve Type—The non-critical orifice is selected and installed to give a constant differential pressure reading at the desired mass flow. Needle valve is used for setting desired mass flow

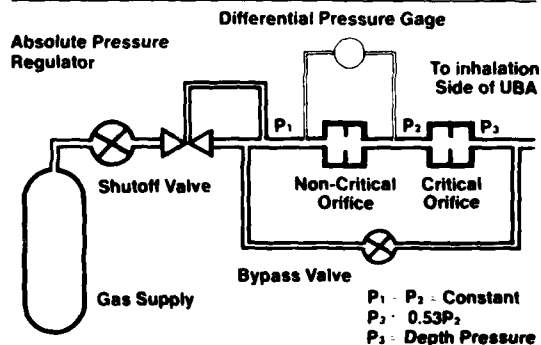

Double Replaceable Orifices Type—The non-critical orifice is selected, installed and used as above. A separate critical orifice is selected and installed for the desired mass flow

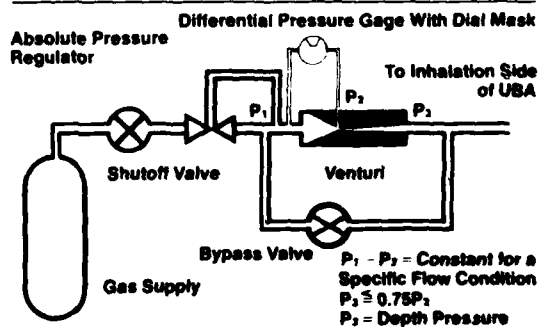

Venturi Type—Desired mass flow rate is set by adjusting regulator to specific delivery pressure (P₁). Differential pressure reading will vary depending on specific mass flow selected. Dial mask is rotated to show needle at correct P for selected mass flow.

Figure 11-4 Typical systems used to provide constant mass flow and flow indication in semiclosed-circuit UBA's.

The absolute pressure regulator maintains a constant pressure output to the restrictor by automatically compensating for depth changes, using a housing sealed at one atmosphere (or vacuum to avoid temperature effects) which resists hydrostatic pressure or a combination of these elements. The regulator is precisely set at the surface with a test gage for the particular restrictor or restrictor setting required to achieve desired mass flow. This setting is maintained throughout the dive.

C. MASS FLOW INDICATION—If the injection gas flow into the recirculation system is partially or totally restricted (usually due to blockage in the critical flow device), hypoxia can result. Consequently for safety, some form of injection flow indication must be available to the diver.

Flow indication is accomplished in a variety of ways (as shown in Figure No. 11-4) including differential pressure gages installed across flow devices. Proper oxygen concentration can also be determined by use of galvanic oxygen partial pressure sensors with signal lights or audible alarms. Such mechanical or electronic systems are supplemented by diver observation of gas flow from the exhaust valve. At constant depth, gas will be exhausted from the apparatus as long as there is an injection flow into the system.

The use of a differential pressure gage for flow monitoring is the most common technique. The gage cannot be placed across the critical flow restrictor because if the restrictor becomes plugged the gage will continue to read the difference between regulator delivery pressure (upstream) and depth pressure (downstream) even though flow has ceased. Pressure difference must be monitored across a device with independent flow characteristics. Typical of this arrangement is the use of a separate flow restrictor in the MK 6 apparatus which is preselected and installed in the control block to give a 3 psi differential pressure at the desired flowrate. A gage attached to the front of the vest is connected by two hoses across the restrictor, and the gage needle remains centered as long as proper flow is passing through the critical orifice (needle valve) downstream in the system. Use of the apparatus at other flow conditions requires installation of a different restrictor in the line calibrated

at the new flow to produce the same 3 psi pressure drop.

A small inline venturi can also be used for flow indication. Pressure taps at the convergent and divergent portions of the venturi provide a differential pressure reading to the gage proportional to flow through the nozzle. By use of a locking mask on the gage face, the safe flow range for a given setting of the regulator is indicated to the diver by the gage needle showing in the mask aperture. This type of system permits the use of a single flow indicator element for different desired flowrates; associated gage readings are accommodated by changing the position of the gage mask.

D. EXHAUST—Since a semiclosed UBA has a continuous inflow of mixed gas into the breathing circuit, there is an associated exhaust to the surrounding water at constant depth conditions. Although inflow is continuous, actual exhaust flow tends to occur cyclically every two or three breaths due to seating and unseating pressures of the exhaust valve. The exhaust valve is located either on the exhalation bag on the diver's vest or in the backpack assembly. The valve is normally adjustable from 1.8 in. of H₂O to 24 in. of H₂O. The exhaust system pressure adjustment controls the degree to which the breathing bags are filled. The exhaust valve is adjusted so that the breathing bags stay filled with enough gas for a full breath, but not so full that the diver must exhale into completely inflated bags. A diaphragm in the exhaust valve senses the water pressure to maintain the required differential pressure at constant depth and during ascent. The valve may also be equipped with a manual override for bag deflation and a muffler-diffuser to minimize telltale bubbles and noise propagation in clandestine operations.

E. GAS SUPPLY—Most semiclosed UBA's have integral gas supplies in the form of high pressure cylinders carried in the backpack assembly. Semiclosed SCUBA's are equipped with two manifolded cylinders containing the supply mix for compactness (rather than a single larger cylinder). Occasionally the supply cylinders are complemented with a smaller third cylinder filled with pure oxygen for use during in-water oxygen decompression. The mixed gas supply furnishes the required injection gas at constant

depth and also, through a manual bypass valve in the control block or a demand regulator, provides makeup gas to the system during descent. The bypass is also used for purging the system if a malfunction is suspected.

Semiclosed UBA for use from a PTC also carry cylinders in the backpack containing premixed helium-oxygen which is physiologically safe for direct breathing at the operating depth. The difference, however, is that these cylinders are reserved for emergency use in the event that the primary gas supply through the umbilical from the PTC is lost. The diver's gas supply is normally drawn from a separate group of cylinders which are a part of the onboard PTC supply. Transfer from PTC to integral supply is accomplished by a switchover valve on the apparatus. Sufficient gas is carried in the diver's backpack to permit return to the safety of the PTC.

F. COMPONENT ARRANGEMENT—Major components of the semiclosed UBA are mounted on a rigid frame backpack which is contoured and supported on the diver for minimum interference during swimming. The backpack contains the two gas supply cylinders, scrubber system, pressure regulator and often provides a mounting for one or two breathing bags and the flow control system (Figure No. 11-5). Some models have the breathing bags attached to the front of an apparatus supporting vest, and some also have a control block containing the flow control, bypass and pressure gage mounted in one module attached to the vest for convenience.

Most UBA have a streamlined, readily detachable cover over the backpack assembly to minimize snagging.

CLOSED-CIRCUIT 11.1.2.2. To extend underwater endurance of mixed-gas UBA without increasing the gas supply, it is necessary to employ a completely closed system in which oxygen concentration in the system is directly controlled, rather than by the indirect method of using a preset mass flow. While perhaps functionally simpler in principle, the closed-circuit mixed-gas UBA tends to be more complex than the semiclosed because of the oxygen analysis and control circuits required. Offsetting this complexity, however, are several inherent advantages:

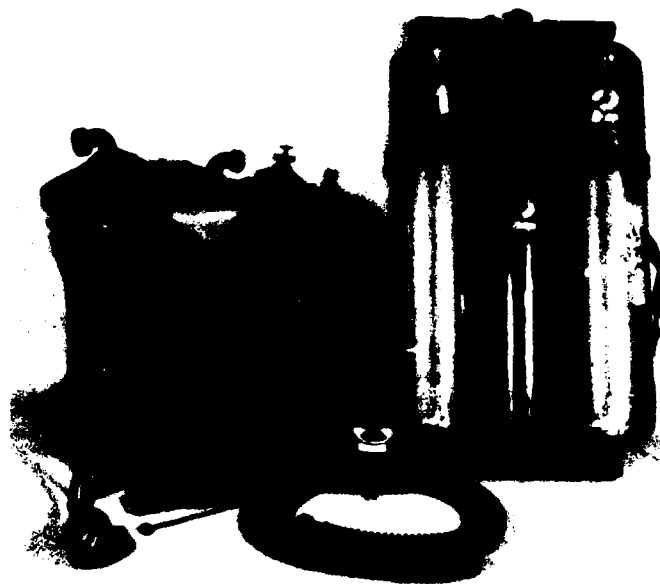

Figure 11-5 Component layout of a semiclosed-circuit UBA.

1. Aside from mixed or diluent gas addition during descent, the only gas required at depth is oxygen to make up for metabolic consumption. Consequently, duration is essentially independent of operating depth.
2. Since the partial pressure of oxygen in the system is automatically controlled throughout the dive to a preset value, dives may be made from the surface to great depths. Additionally, no adjustment is required during a dive for variations in depth and work rate.
3. Since no inert gas leaves the system except by accident or during ascent, the closed-circuit UBA is bubble-free and thus well-suited for clandestine operations.
4. No parts need be changed in the apparatus during pre-dive calibration.

A. OXYGEN ANALYSIS AND CONTROL—(Figure 11-6). The primary electronic module (28), powered by the battery (8) and activated by a switch (27), monitors ppO_2 in the recirculating gas by means of three sensors. The primary electronic module computes an average from the individual ppO_2 measurements of the sensors. This information appears on the wrist-mounted primary display (9) as an illuminated letter or number to indicate a normal, high or low level of oxygen. Once every five seconds, the electronic module compares the average ppO_2 value with the setpoint

valve. A ppO_2 value less than the setpoint value automatically opens a solenoid valve (10) in the oxygen supply line to admit a pulse of approximately 1/3 liter of oxygen to the system. The amount of oxygen admitted each time the valve opens (measured STPD) is constant, independent of depth. The pulse of oxygen flows from a small accumulator (11) into the recirculator loop. The accumulator is pressurized with gas

at a controlled pressure of approximately 110 psi above ambient. The regulator (16) maintains the pressure level. Oxygen is stored in a spherical bottle (13) fitted with a manual shutoff valve (14). The O_2 bypass valve (17) allows manual addition of oxygen to the breathing gas when required. The O_2 pressure gauge (18) displays the oxygen bottle pressure level.

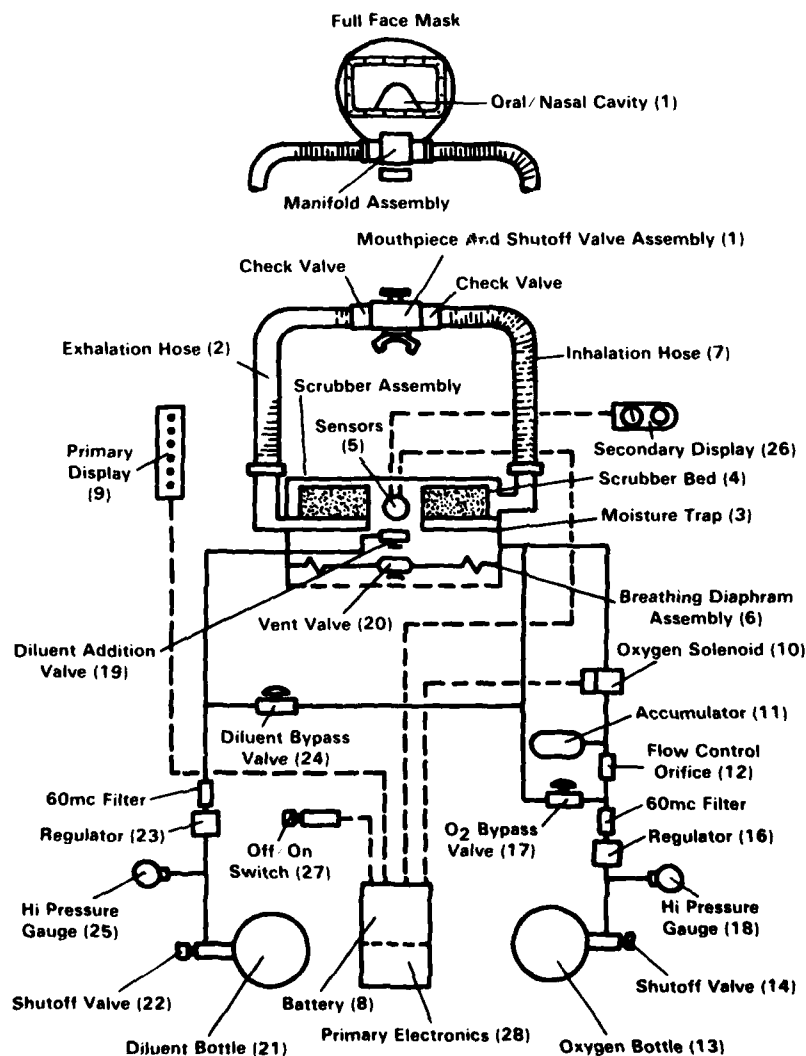

Figure 11-6 Functional Diagram of a Typical Closed-Circuit UBA

B. RECIRCULATION SYSTEM—(Figure 11-6). The diver exhales into his mouthpiece or the oral-nasal cavity of the manifold when the Full Face Mask (FFM) is worn (1). The exhaled breath passes through the exhalation hose (2), over a moisture trap (3), and then through a bed of absorbent granules in the scrubber (4 where the CO₂ is removed. The gas then passes over the oxygen sensor assembly (5), into the diaphragm assembly (6), and back to the diver via the inhalation hose (7).

C. DILUENT SUPPLY—As the diver descends, the increased water pressure activates the diluent addition valve (19), maintaining the total pressure within the recirculation system at ambient water pressure. As the diver ascends, the water pressure lessens and the vent valve (20) opens to discharge breathing gas into the surrounding water. The diluent gas is contained in a spherical bottle (21) with a manual shutoff valve (22) and regulator (23). A bypass valve (24) allows direct addition of diluent to the breathing mixture when required. A pressure gauge (25) provides a visual indication of the diluent gas pressure.

D. PRIMARY DISPLAY—The primary electronics module (28) computes an average from the individual ppO₂ measurements of the oxygen sensors (5). This information appears on the primary display (9) as an illuminated letter or number to indicate a normal, high or low of oxygen.

E. SECONDARY DISPLAY—A secondary display analog meter (26) indicates ppO₂ measured by the oxygen sensors. The secondary display also indicates the primary electronic module's battery voltage (plus and minus) and is secured to the harness waist strap by means of a snap link.

U.S. NAVY UBA 11.2

At the present time there are three models of mixed-gas underwater breathing apparatus approved for use in Navy diving. These units, designated the MK 6, MK 11, and MK 15 have been rigorously tested under

laboratory and field conditions to insure the reliability, durability and safety required of USN diving equipment.

All mixed-gas UBA are mechanically more complex than more commonly encountered surface-supplied and air SCUBA equipment. Consequently, adequate diving safety is only achieved when the diver has been thoroughly trained with the **particular model of apparatus** to be used, the equipment has been **properly calibrated** for the specific diving conditions to be encountered, and the dive is conducted **within the associated depth and duration constraints**.

The following sections of this chapter provide detailed information on each apparatus. Included is a description of the equipment, principles of operation, calibration and adjustment, pre-dive checkout, underwater procedures, and post-dive checks. The information presented, combined with suitable training, provides the basis for safe underwater use of the apparatus. *The reader is referred to the instruction and maintenance manuals for each model of equipment for detailed information concerning trouble-shooting, maintenance and repair.*

The three models of UBA included in the manual are—

MK 6 MOD 0—Semiclosed-Circuit UBA

Application—combat swimming and EOD operations
Depth—to 200 feet

MK 11 MOD 0—Semiclosed-Circuit UBA

Application—PTC diving (tethered)
Depth—to 650 feet

MK 15 MOD 0—Closed-Circuit UBA

Application—combat swimming and EOD operations
Depth—to 150 feet (using air as diluent)

MK 6 MOD 0 MIXED-GAS UBA 11.3

The MK 6 (Figure No. 11-7) apparatus is a semiclosed-circuit UBA designed for combat swimmer and EOD SCUBA applications at moderate depth (to 200 feet). It consists of a backpack containing a self-contained gas supply, scrubber, and injection gas regulation system. The backpack is supported on a vest to which is attached two front-worn breathing bags. The addition of system pressurization gas is manually controlled. Injection flow indication is by means of a constant reading, differential pressure gage worn on the vest. The MK 6 is occasionally fitted with an additional cylinder containing oxygen for use during decompression.



Figure 11-7 U. S. Navy Diver outfitted with the MK 6 UBA.

Breathing Circuit 11.3.1 An initial understanding of the apparatus can best be achieved by tracing the flow of gas through the system (Figure No. 11-8).

1. When the diver takes a breath, a one-way inhalation valve in the right side of the mouthpiece opens, admitting gas (through the inhalation hose) from the inhalation breathing bag.
2. Upon exhalation, the carbon dioxide-laden gas is directed through the one-way exhaust valve on the left side of the mouthpiece through the exhalation hose into the exhalation breathing bag. This incoming volume of gas forces the gas already in the breathing bag through the left breathing hose and down through the outer shell of the scrubber assembly.
3. The inner shell of the scrubber, or canister, contains an approved absorbent. As the exhaled gas filters through the absorbent, the carbon dioxide is removed.
4. As the now-purified gas reaches the top of the canister, it is mixed with a pre-determined quantity of fresh gas from the cylinders, and this mixture is passed through the right breathing hose into the inhalation breathing bag where it mixes with the recirculating gas.

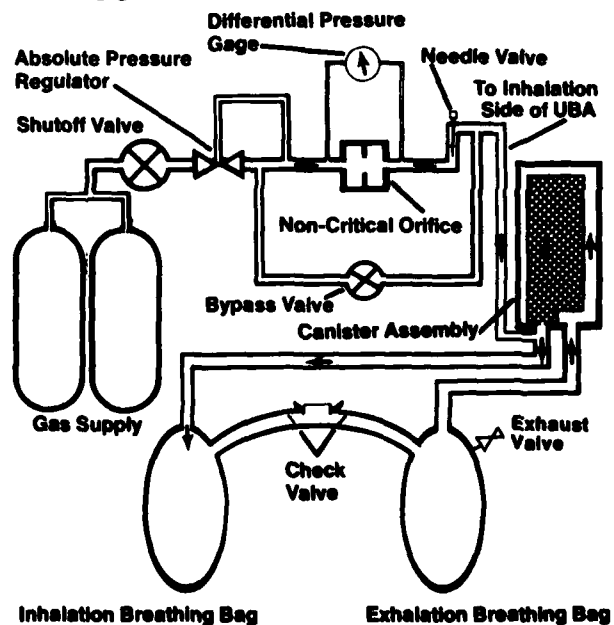

Figure 11-8 MK 6 UBA schematic.

5. The injection gas is metered through an absolute pressure regulator, flow indicating orifice and needle valve at a pre-set mass flowrate. Prior to the dive, the diver installs an orifice of the appropriate size for proper flow indication and sets the needle valve to provide a flow of mixed gas sufficient to replace the oxygen which he will be consuming at the anticipated work rate. The absolute pressure regulator automatically maintains injection gas pressure at a set value regardless of depth change.

6. Because there is a constant mass of mixed gas entering the system and only the oxygen in this gas is consumed, a volume of recirculating gas must discharge from the system into the water. This discharge occurs at the end of every few exhalation cycles as the exhalation breathing bag is refilled. An exhaust valve, mounted on the breathing bag, opens when the pressure in the bag reaches a pre-determined level (which can be adjusted by the diver). If at any time the system fails to maintain a degree of exhaust, it is probable that the inflow of fresh gas from the supply cylinders has been decreased. This condition should be regarded as a warning signal.

Description of Components 11.3.2 The MK 6 apparatus is made up of the following specific components—

1. The backplate carries the cylinders, attached manifold and valve assemblies, and the canister assembly. The backplate is secured to the vest assembly by a toggle pin at the top and three pairs of retaining straps at the sides.
2. The twin gas cylinders are connected with a manifold valve assembly at the top and secured by a spreader bar at the bottom to form a single unit for handling and charging. The aluminum cylinders are hydrostatically tested to 5,000 psi and have a combined capacity of 84 cubic feet of gas at standard conditions when fully charged to 3,000 psi. A stud at the bottom of each cylinder accommodates the spreader bar. The manifold valve assembly is mounted on the cylinders through a pair of elbow fittings which are sealed to the neck of each cylinder with a preformed packing. One of the elbows contains a safety disk which is preset to rupture in the range of 3,375-3,750 psi. The manifold itself contains a



Figure 11-9 Diver outfitted with the MK 6.

shutoff valve and has a fitting for the attachment of the regulator valve assembly. The cylinders are charged through this same fitting by using a special charging line assembly.

3. The regulator assembly is attached to the manifold and has a fitting for the attachment of the control block assembly (see Item 4, below). The regulator is a pressure compensated control valve which ensures delivery of mixed gas at approximately the same pressure regardless of depth. The regulator employs a sealed bellows containing a spring and a diaphragm assembly which responds to ambient and upstream orifice pressure. A valve, attached to the diaphragm, responds to changes in diaphragm position to throttle supply flow and maintain a constant pressure upstream of the needle valve.
4. The control block assembly contains a fixed orifice (with filter), the size of which is selected in advance of the dive to provide a 3 psi pressure drop at the computed flow requirements of the diver. The orifice comes in three sizes: 8, 12 and 21 liters per minute. Outlets are located downstream and upstream of the orifice with fittings which connect with a differential pressure gage. This gage is used to monitor injection gas flow in the SCUBA during a dive. A needle valve is located downstream of the orifice to provide an adjustment of the rate of gas flow into the system.

The needle valve, when properly positioned, is locked in place by a jam nut. Other units of the control block assembly include an *on-off valve*, a *by-pass valve* (to permit unrestricted flow of gas from the regulator assembly for apparatus pressurization during descent) and a *check valve* (to prevent by-pass flow from entering the rest of the assembly).

5. The **scrubber assembly** is composed of two units. The **inner shell**, which holds approximately 6½ pounds of absorbent is fitted with a screen at each end. A spring unit at the bottom serves to hold the inner shell firmly in position within the outer shell. The **outer shell** is a water tight unit which provides a channel (between the walls of the inner and outer shell) through which the exhaled breath is directed to the bottom of the canister. The top of the outer shell has fittings for two hoses: the **left breathing hose** from the exhalation breathing bag, and the **right breathing hose** leading from the inner shell to the inhalation breathing bag. A gas inlet block mounted the right-hose fitting serves to admit replenishment gas as metered through the regulator and control block.

6. The **vest** covers the diver's chest. It is secured in front by a zipper and attached to the backplate by three pairs of straps. The vest serves two purposes: to provide a comfortable means of wearing the backplate and tank units and to hold the **breathing bags**. These bags each hold about 4 liters of gas when fully inflated and are attached to the vest with six common-sense fasteners. Each breathing bag is fitted with two hose connectors—one for the hose leading to or from the mouthpiece, and one for the hose leading to or from the canister assembly. Each bag also has a drain plug to facilitate post-dive cleaning and drying. The exhalation bag (on the left) carries the **exhaust valve assembly**. This is an adjustable spring-loaded relief valve which may be set to maintain a system pressure between 0.25 psi and 1.0 psi over ambient. The proper system pressure is determined by the diver himself, and the valve should be set so that a small quantity of gas is vented with each breath—or, at least, with every third breath. Adjustment of the exhaust valve also permits the diver to make small changes in buoyancy to control trim. The exhaust valve can be manually opened by a "pull grip" for quick release of excess pressure.



Figure 11-10 MK 6 UBA (Note: cylinders, manifold and regulator)



Figure 11-11 MK 6 regulator assembly.

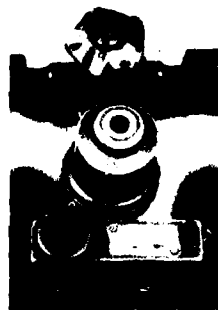

Figure 11-12 MK 6 control block assembly.



Figure 11-13 MK 6 canister assembly (between cylinders).

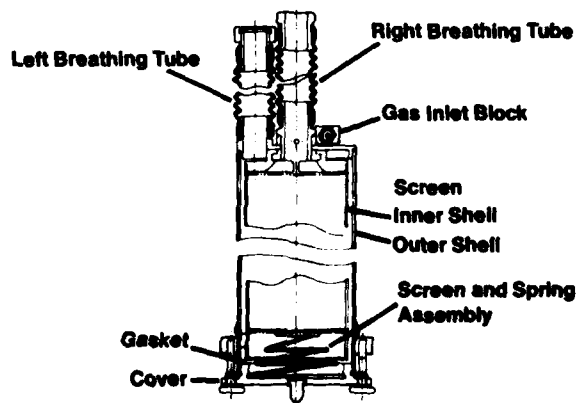

Figure 11-14 Cross section of the MK 6 canister.



Figure 11-15 Flow adjustment procedure for the MK 6.



Figure 11-16 MK 6 vest.



Figure 11-17 MK 6 mouthpiece assembly.

7. The final unit of the MK 6 is the **mouthpiece-T tube assembly** and the attached inhalation and exhalation hoses. The mouthpiece assembly contains two one-way check valves (for inhalation and exhalation) and a shutoff valve which is manually set to either the **surface** or **diving** position. In the "surface" position, this valve prevents entry of water into the breathing system.

Pre-Dive Preparations 11.3.3 Prior to the start of any dive, the equipment must be thoroughly inspected and the canister must be filled with a fresh supply of approved absorbent.

A vital part of pre-dive preparation is to determine the appropriate gas mixture for the dive and to adjust the apparatus to provide the proper flow of that mixture. There are three settings which must be made—

1. An orifice of the proper size must be selected and installed (to accommodate a maximum flow requirement of 8, 12 or 21 liters per minute).
2. The regulator assembly must be adjusted for the supply pressure required for the installed orifice. These pressures are 80 psi for 8 lpm, 140 psi for 12 lpm, and 180 psi for 21 lpm. Pressure setting is determined with a test gage.
3. The control block metering valve must be set for the pre-determined flow rate using a calibrated flow meter.

A comprehensive Pre-Dive Equipment Preparation Checklist is contained in Appendix D. The breathing mixture must be selected to provide adequate levels of oxygen in the system at operating depth. As a practical matter, to assist in decompression and to minimize the possibility of decompression sickness, the breathing mixture should contain the highest concentration of oxygen that will not result in oxygen poisoning. The metering valve setting must be adjusted, in consonance with the breathing mixture in use, to provide sufficient oxygen to replace that which is being consumed by the diver.

The lowest permissible level of oxygen in the inhalation bag is 16 percent. In underwater swimming, the highest sustainable rate of oxygen consumption is approximately 3.0 liters per minute. Therefore, the minimum permissible inflow of any gas mixture will be that which would maintain a 16 percent oxygen level in the inhalation bag at an oxygen consumption rate of 3.0 liters per minute. Table 11-1 lists the mixed-gas supply flow rates required to maintain this condition. The table lists both actual and measured flow rates in liters per minute. The actual flow rate is that measured by a flow meter calibrated for the gas being measured. The flow meter supplied with the MK 6 test kit is calibrated using air, and consequently the flow

TABLE 11-1 — MIXED-GAS FLOW RATE TABLE; MK 6 MOD 0 SCUBA

Inert gas	Maximum Oxygen percent	Type of exercise	Actual flow, liters per minute	Measured flow, liters per minute	Maximum depth,* feet
Nitrogen	60	Swimming	8	8	55
	40	Swimming	12	12	97
	32.5	Swimming	21	21	129
Helium	40	Swimming	11	8	80
	32	Swimming	18.5	12.5	180

*Maximum depths noted are non-exceptional exposure limits

meter readings (measured flow) must be referenced to Table 11-1 to determine the actual flowrate of mixed gas.

The maximum permissible level of oxygen in the bag will be that which, at the maximum operating depth of the dive, does not exceed a partial pressure of 1.6 ata (N₂-O₂) or 2.0 ata (He-O₂). To introduce a safety factor into the computation of this level, the percent of oxygen in the mixed-gas supply is used. The actual concentration of oxygen in the breathing bag will always be somewhat lower than in the supply because of dilution by recirculating gas in the system. Maximum allowable oxygen percentage in the supply mix can be determined using the formulas in Section 11.1.2.1.

Once the required surface flow rate has been determined, the gas-supply duration may be calculated. In making this calculation, an allowance of 10 percent of the supply for volumetric requirements on descent and 10 percent for a safety factor is ample for most situations. The combined 20 percent is taken into consideration by using a cylinder low-pressure safety limit of 20 percent of the cylinder pressure rating. The gas supply duration is calculated using the following formula—

$$t = \frac{V(p - s)}{14.7(f)}$$

Where—

- t = Gas supply duration, minutes
- V = Total cylinder volume, liters
- p = Initial charging pressure, psi
- s = Low-pressure safety limit, psi
- f = Surface flow rate, lpm

EXAMPLE—

PROBLEM—A diver equipped with a MK 6 apparatus set for 21 lpm injection flowrate and cylinders charged to 2,800 psi is to make a dive to 130 feet. What is the maximum allowable dive duration?

SOLUTION—The two cylinders of the MK 6 have an internal volume of 12 liters. The low pressure safety limit is 20% of 3,000 psi (maximum charging pressure) or 600 psi.

Substituting—

$$t = \frac{V(p - s)}{14.7(f)} = \frac{12 \text{ liters } (2,800 \text{ psi} - 600 \text{ psi})}{14.7 \text{ psi/atm } (21 \text{ lpm})}$$

$$= \frac{12(2,200)}{14.7(21)} = 85 \text{ minutes}$$

Diving Procedures 11.3.4 Standard SCUBA diving procedures, as discussed in Chapter Five, Volume I, including safety precautions and communications, are used when diving with the MK 6. The following special instructions, however, must also be followed—

1. During descent, manually actuate the bypass valve to keep the breathing bags properly inflated (about 2/3 capacity). If pressure balance is not maintained, breathing effort will increase, and gas starvation and squeeze may occur.
2. Upon reaching the desired depth, readjust the exhaust valve setting to maintain the proper bag inflation.
3. At depth, work normally. Avoid extreme exertion unless the gas flow was originally set for heavy work.
4. Continuously monitor the differential pressure gage reading and the operation of the exhaust valve.

Unless the exhaust is constant and regular (at least every third breath) and the gage needle remains in the safe zone, a failure of the injection gas supply system must be assumed, and emergency procedures must be initiated.

5. If malfunction of the mass-flow system or carbon dioxide scrubber is suspected, purge the UBA with supply gas and abort the dive.

6. Prior to ascent, flush the breathing bags by using the following procedure—

- Assume a position such that the exhaust valve is above the bag.
- Take several deep breaths and exhale normally.
- Open the exhaust valve using the pull grip and let the water pressure flatten the bag.
- Release the pull grip.
- Open the bypass and fill the bag to the normal level. Do not exhaust any gas from the system.

7. If the bags should become over-inflated—as during ascent, or if the exhaust valve is not properly set—manually pull the exhaust valve “pull grip” to dump the excess pressure.

8. For quick inflation of the bags, as for example to aid in an emergency ascent, manually actuate the bypass valve. Care should be taken, however, to avoid over-inflation to the point of bursting the bags during ascent.

9. When ascending from a dive that does not require decompression, stop at 30 feet and purge the breathing bags before completing the ascent.

10. When using a MK 6 without an auxiliary oxygen supply, the breathing bags should be flushed with the gas mixture in use at each decompression stop. Even if the first stop is above 30 feet, the bag must first be purged when the diver reaches 30 feet.

11. Some units of the MK 6 SCUBA have been equipped with an auxiliary oxygen supply for use during decompression. This modification uses a standard oxygen cylinder and regulator from the US Navy closed-circuit oxygen apparatus and provides for input of oxygen into the system through the drain valve of the inhalation breathing bag. If the MK 6 unit in use is equipped with this oxygen supply, follow these procedures—

—Ascend to the first decompression stop. If this is deeper than 30 feet, purge the breathing bags with the gas mixture in use and complete the decompression stops as required. Purge the breathing bags upon arrival at each stop until reaching 30 feet.

—Upon arrival at the first oxygen stop (20 or 30 feet), turn off the mixed-gas supply and turn on the oxygen supply. Purge the breathing bags three times with oxygen, then complete the required decompression using oxygen.

—The shift to oxygen must take place at 30 feet even if the first decompression stop is scheduled for 20 feet.

Post-Dive Maintenance and Troubleshooting

11.3.5 Upon completing a dive with the MK 6 SCUBA, the following post-dive procedures should be conducted—

1. Close the manifold shutoff valve and the mouth-piece valve.
2. Thoroughly rinse the breathing apparatus in clean fresh water. Clean all breathing passages with fresh water and medicated soap.
3. Remove the drain plugs from breathing bags and allow the bags to completely dry.
4. Remove used Baralyme pellets from the canister assembly, and thoroughly rinse the assembly.
5. Tag out cylinders as being empty.
6. Inspect the regulator assembly, safety rupture disc, and exhaust valve assembly for any contamination or damage. Check the regulator flow. If it has varied more than 10% from pre-dive readings, closely examine the assembly for malfunction.
7. To prepare the MK 6 for storage—
 - Unlatch the cylinder straps.
 - Close the manifold valve assembly.
 - Actuate the bypass valve ring several times.
 - Back off the regulator spring button.
 - Remove fabric components and preserve.
 - Use a specified preservative on all rigid parts and fittings.
 - Store in protective boxes in a cool, dry place.

Troubleshooting procedures for the MK 6 MOD 0 are tabulated in Appendix A.

MK 11 MOD 0 UBA AND ASSOCIATED EQUIPMENT 11.4

The UBA MK 11 MOD 0 and Associated Equipment (Figure 11-18) is a complete system of equipment providing the life support and thermal protection necessary to enable divers to operate at depths as great as 650 feet and water temperatures as low as 30° F (-1° C). Designed primarily for semi-closed circuit use, a support facility (PTC) is required to supply mixed gas, power and communications, and hot water to the diver through his umbilical. The UBA MK 11 MOD 0 and Associated Equipment is a specialized system of equipment to be used by specially trained and experienced divers.

The primary groupings of hardware in the UBA MK MOD 0 and Associated Equipment System are:

- Diver Umbilical
- UBA MK 11 MOD 0 (backpack)
- M-11 Face Mask
- Thermal Protection
- Set-up Kit
- Ancillary Equipment

Diver Umbilical 11.4.1 The umbilical consists of a hot water hose, gas hose, and electrical cable. Each has a suitable quick disconnect fitting at the diver end and semipermanent connectors at the support facility end. The hot water hose delivers water with maximum temperature of 110° F (44° C) at 2.5 GPM maximum flow. The gas hose has an inside diameter of 3/8 inch and delivers gas at pressures up to 1260 psi. The electrical cable is a 7 conductor cable which carries communications signals to and from the diver as well as supplying power to the emergency gas switchover indicator, and ppO₂ sensor amplifier.

UBA MK 11 MOD 0 (Backpack) 11.4.2 The UBA MK 11 MOD 0 (Figure 11-19) contains the breathing gas regulation, CO₂ removal, emergency breathing gas supply, switchover sensing, and exhaust equip-

ment for the breathing system. The backpack assembly is contoured to fit the diver's back. The breathing bags, with an attitude sensitive exhaust valve, fit against the diver's back and enable breathing effort to be reduced to the minimum practical value. Hot water is taken from the diver umbilical and passed around the CO₂ removal canister before being delivered to the diver's hot water suit. The breathing subsystem has 4 modes of operation: (1) Semi-closed circuit, umbilical supplied (endurance is established by CO₂ removal capacity); (2) Open circuit, umbilical supplied (endurance is limited by gas supply); (3) Semi-closed circuit, emergency gas supplied (endurance is 15 minutes at 600 feet). Selection of semi-closed or open circuit operation is made by the diver. Contained within the backpack is a 35 scf emergency gas supply which is automatically turned on if the umbilical supply pressure drops. Shortly after this switchover takes place, a warning light (switchover indicator light) in the diver's facemask is illuminated. Contained within the inhalation breathing bag is a ppO₂ sensor and amplifier which transmit the ppO₂ level to the support facility.

M-11 Facemask 11.4.3 The facemask (Figure 11-20) contains an oral-nasal cup in which is mounted the diver microphone, switchover indicator light, a face seal, and the second stage of the demand (open circuit) breathing subsystem. The facemask is connected to the UBA MK 11 MOD 0 by inhalation and exhalation hoses for semi-closed circuit operation, a shutoff valve and supply hose for open circuit operation, and an electrical cable for communications signals and switchover indication.

Thermal Protection 11.4.4 Thermal protection is provided by a non-return valve (NRV) hot water suit. Hot water flow comes from the UBA MK 11 MOD 0 CO₂ removal canister. A control block, located at hip level, allows the diver to regulate the amount of water going into the suit and the flow which is delivered to the front and rear of the suit. The hood of the hot water suit contains pockets to hold the communications earphones in place. The NRV suit is worn over a 1/8" inner neoprene liner, used mainly for protection against hot water burns.

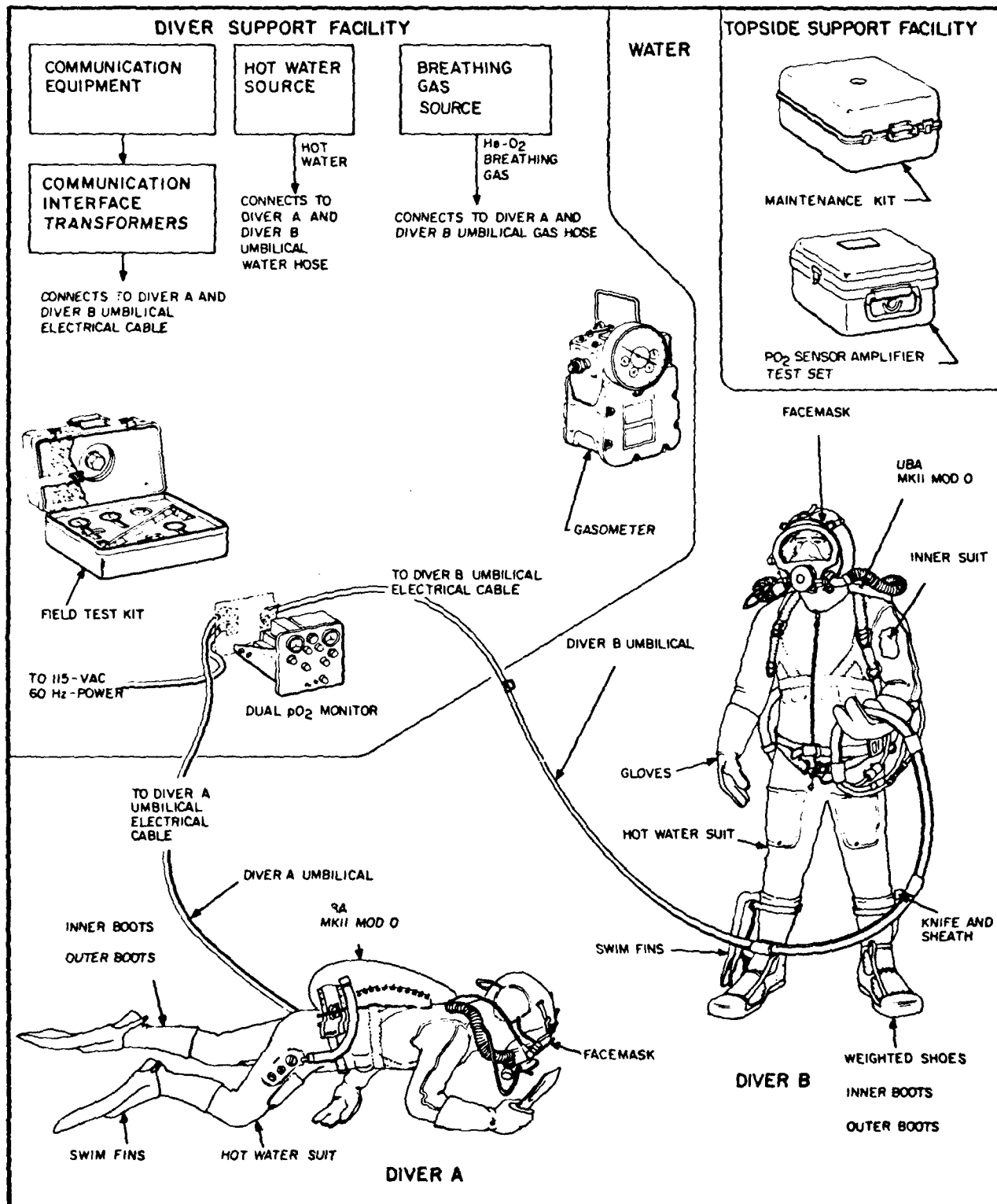

Figure 11-18 MK 11 Mod 0 System

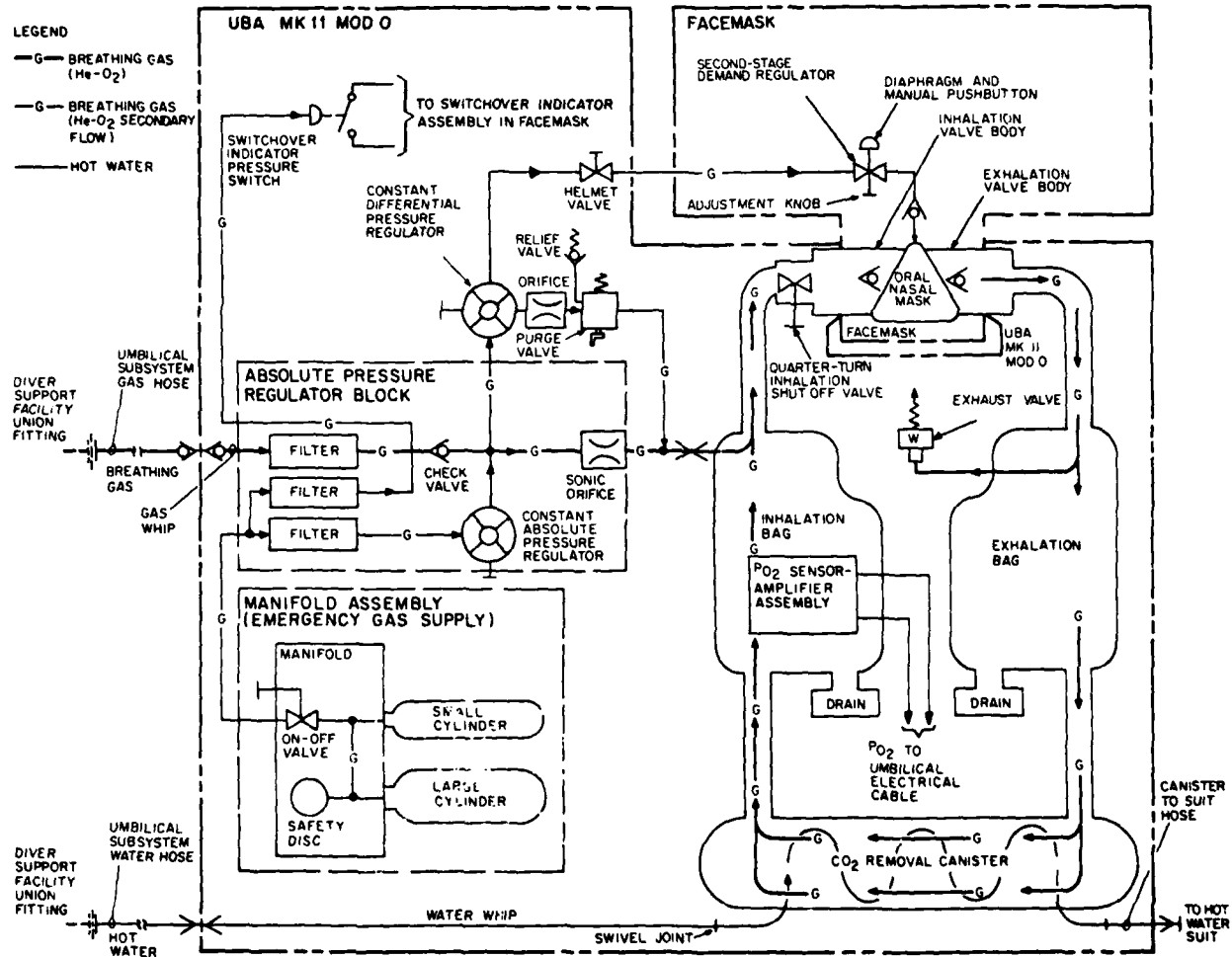
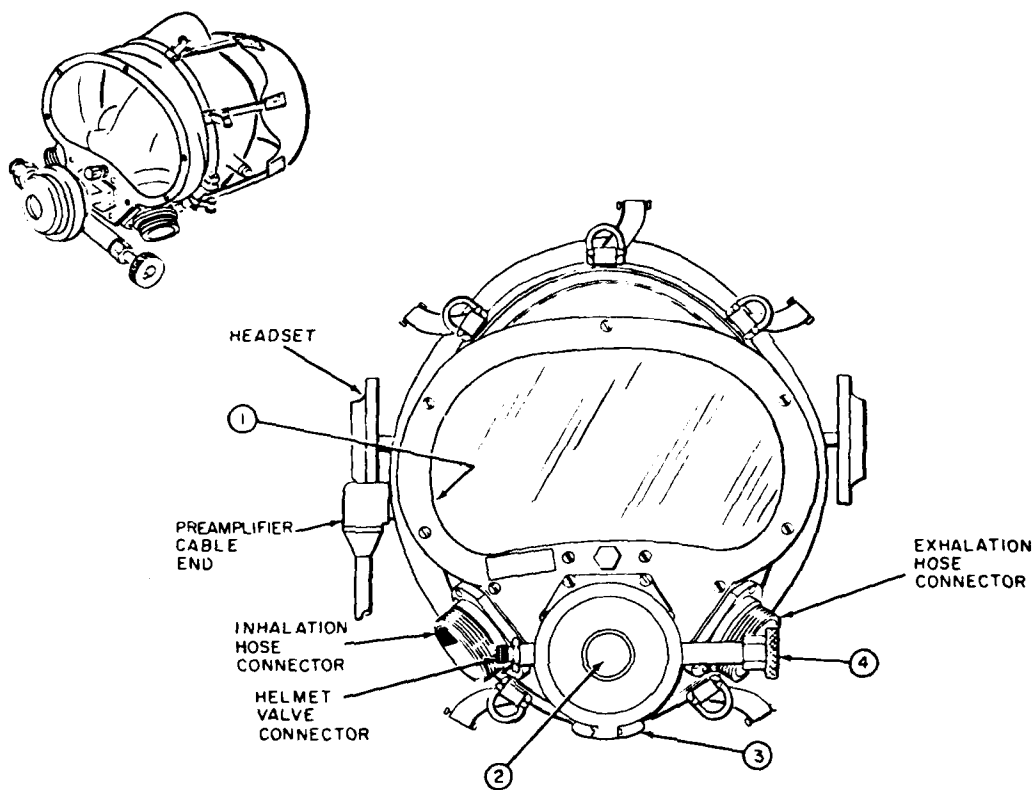

Figure 11-19 MK 11 Mod 0 UBA Schematic Diagram



INDEX NO.	NAME	TYPE	POSITIONS OR COLOR	FUNCTIONS (EACH POSITION)
1	Switchover Indicator Assembly	Light emitting diodes	Red	Lights to indicate the diver is using the emergency gas supply.
2	Manual Flush Purge Button	Spring-loaded Pushbutton	Out, In	Supplies fresh gas to the oral-nasal mask and forces water from oral-nasal mask when helmet valve is open.
3	Waterpurge Button	Spring-loaded Pushbutton Cover	Out, In	Allows the diver to purge water from the eye cavity portion of the helmet faceplate.
4	Demand Regulator	Twist Knob	CW-Increase CCW-Decrease	Increases pressure needed to open regulator. Decreases pressure needed to open regulator. Free flow occurs when full CCW position is used or neared. WARNING Do not open this knob more than 10 turns from fully closed position or the regulator can be damaged, placing the diver in danger.

Figure 11-20 MK 11 Facemask

Set-up Kit 11.4.5 The set-up kit is used for setting up or trouble shooting the UBA. It contains pressure gauges, flow meters, and supporting valving and plumbing equipment. It can support two MK 11 MOD 0 backpacks and two M-11 facemasks simultaneously.

Ancillary Equipment 11.4.6 Included in the equipment are such items as weighted shoes for working on the bottom, fins for swimming, diving lights, knives and weights.

MK 15 MOD 0 MIXED-GAS UNDERWATER BREATHING APPARATUS 11.5

The MK 15 UBA (Figure 11-21) is a closed circuit rebreather designed for combat swimmer operations at a depth of up to 150 feet. It is broken down into four basic subassemblies—

1. An equipment case assembly, including an outer housing cover and a harness assembly.
2. The recirculation system, consisting of a closed loop incorporating inhalation and exhalation hoses, a mouthpiece (or full face mask), a carbon dioxide removal unit, and a flexible breathing diaphragm.
3. A pneumatics assembly, containing oxygen and diluent storage bottles, and pressure reduction and gas addition mechanisms.
4. An electronics assembly that serves as an oxygen analysis and control system to monitor the ppO_2 level in the recirculation system.

Equipment Case Assembly 11.5.1 Major components of the UBA are housed in a reinforced fiberglass-molded case. The equipment case is a contoured backpack assembly designed for minimum interference during swimming. A streamlined, readily detachable outer cover minimizes the danger of underwater entanglement.

Recirculation System 11.5.2 The diver's breathing gases are recirculated in the MK 15 to remove

carbon dioxide and permit reuse of the inert component of the diluent in the breathing mixture. Movement of recirculating gas through the circuit is accomplished by the natural inhalation and exhalation action of the diver's lungs. Inhalation and exhalation check valves in the mouthpiece assembly (or manifold of the full face mask) ensure the unidirectional flow of gas through the system.

SCRUBBER ASSEMBLY 11.5.2.1 The scrubber assembly provides the variable volume required for diver breathing. The assembly outer shell has a removable cover, a center section attached to the fiberglass equipment case, and a flexible rubber breathing diaphragm. An absorbent disc inside the cover absorbs any condensation formed on the cover walls.

A. CARBON DIOXIDE REMOVAL—Before the diver's exhaled breath enters the breathing diaphragm, it passes through the scrubber canister. The scrubber canister is filled with an approved absorbent, and efficient CO_2 absorbent which, if inadvertently wetted, produces a minimum of caustic fumes. Two filter discs in the scrubber canister serve as air distributors to minimize effects of channeling due to improper filling of the canister.

B. WATER REMOVAL—Moisture produced by the reaction between CO_2 and CO_2 absorbent and by the diver himself is absorbed by moisture absorbent discs located outside the canister.

OXYGEN SENSING 11.5.2.2. The oxygen concentration in the recirculation system is measured by three sensors which provide an electrical output due to the galvanic reaction of oxygen coming in contact with a sensing electrode. The oxygen sensor is surrounded by the CO_2 scrubber canister and the cover serves as a gas plenum, insulating the canister from the ambient cold water.

Electronics Assembly 11.5.3

OXYGEN ANALYSIS AND CONTROL SYSTEM 11.5.3.1 Oxygen concentration in the recirculation system is measured by the sensors which generate an electrical output through the galvanic reaction of oxygen coming in contact with a sensing electrode.

Sensors are calibrated to a selected setpoint of ppO_2 . The sensors monitor the ppO_2 and send signals to the electronics module, powered by the battery, amplifies or limits signal strength, compares actual ppO_2 value with setpoint value, and controls the electric solenoid valve less than setpoint automatically actuates the solenoid to admit oxygen to the recirculation system.

OXYGEN CONTROL 11.5.3.2

A. SYSTEM REDUNDANCY—In normal operation the electronic logic circuitry averages the three sensors inputs and controls the oxygen partial pressure based on this average value. However, should any one sensor deviate by more than 43 percent from the

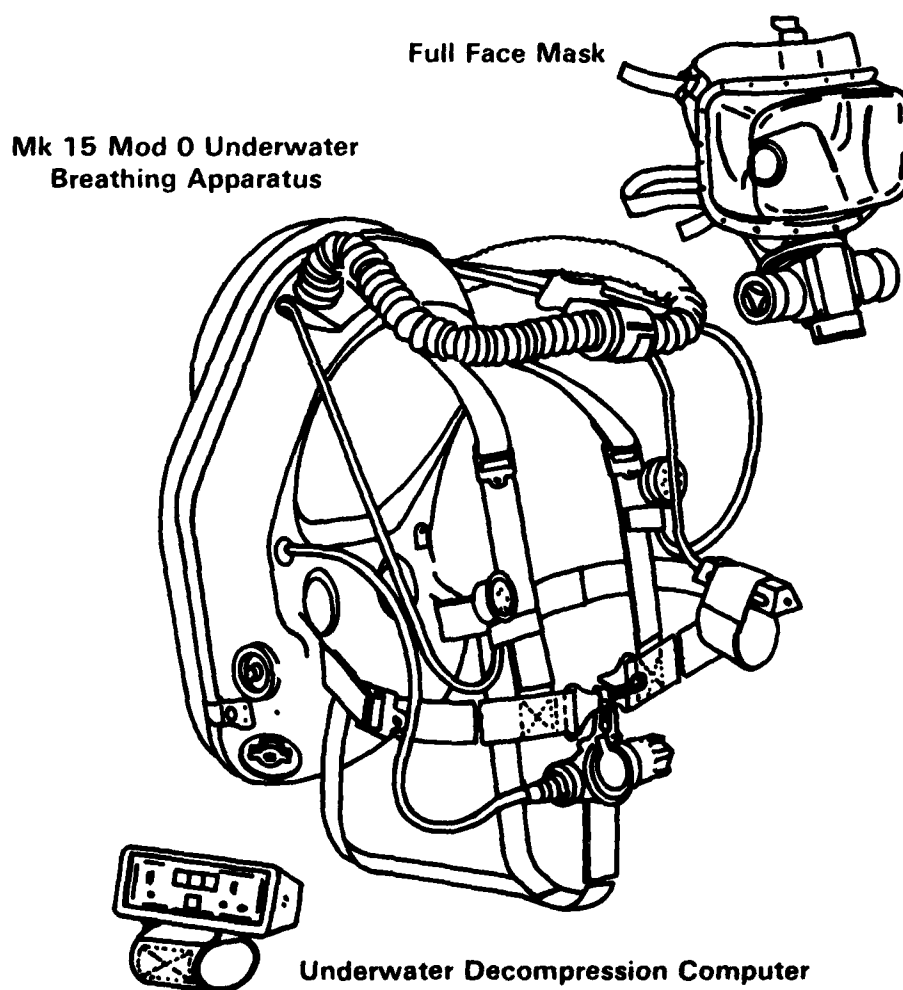

Figure 11-21 MK 15 UBA and Associated Equipment

setpoint, an electronically limited signal is used for that divergent sensor to preclude its significantly changing the average value of the other two sensors. Control of ppO_2 is then based primarily upon the two sensors that are in agreement.

B. SETPOINT CALIBRATION—The normal operational setpoint for the MK 15 is 0.7 atmospheres of ppO_2 . Appropriate calibration procedures are used to preset the 0.7 ATM setting or any other required ppO_2 level between 0.5 and 1.0 ATM.

C. OXYGEN ADDITION—In response to the average sensor outputs, the solenoid valve admits oxygen to the scrubber assembly, where it is mixed with the breathing gas in the recirculation system. This method is called "sampled data" control. The control circuits continuously monitor the average ppO_2 level; if the oxygen partial pressure in the recirculation system is lower than the setpoint level, the solenoid valve is energized to admit oxygen. After five seconds, if the ppO_2 level is still below the setpoint level, more oxygen is added. When the ppO_2 reaches the required level, the automatic control system maintains the solenoid valve in the shut position. Should the solenoid valve fail in an open position, the resulting free flow of oxygen is limited to approximately four liters per minute by a flow restrictor in the pneumatics assembly.

DISPLAYS 11.5.3.3

A. PRIMARY DISPLAY—The ppO_2 portion of the primary display has five illuminated, sequential letters, and numbers to indicate a normal, high or low level of oxygen. When the unit is calibrated to maintain a ppO_2 level of 0.7 atmospheres, the oxygen level corresponding to each light signal is shown in Figure 11-22.

B. SECONDARY DISPLAY—The secondary display is an analog meter which displays sensor output and battery voltage. Individual sensor readouts are obtained by rotating a knob to sensor 1, 2, or 3 dial

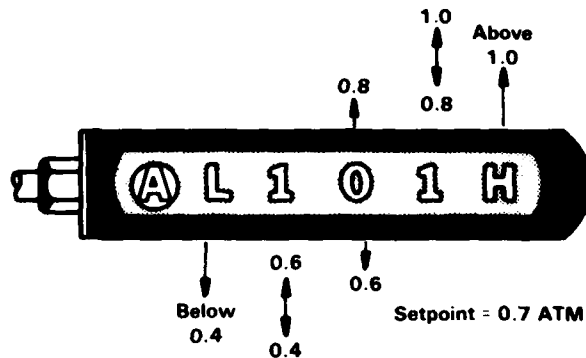

Figure 11-22 Primary display

position. Each oxygen sensor generates sufficient electrical output to activate the meter and does not require signal amplification.

Pneumatics Assembly 11.5.4 The pneumatics assembly comprises—

1. High-pressure bottles for storage of oxygen and diluent gases,
2. Gauges to permit monitoring of the remaining gas supply.
3. Controls and plumbing to regulate and deliver oxygen and diluent gases to the recirculation circuit.

Special Operational Considerations 11.5.5

Because the MK 15 UBA maintains a constant partial pressure of oxygen, adds oxygen or diluent gas only as needed, and the diver's decompression obligation is constantly calculated by the diver-worn decompression computer, long duration, multiple depth dives are possible. Mission capabilities, dive pro-

deures and decompression requirements for the new MK 15 UBA are therefore radically different from any existing methods. The following dive procedures are unique to MK 15 UBA diving:

a. Decompression stops are required for most deep dives.

b. Tables are provided for decompression diving when an Underwater Decompression Computer (UDC) is not available. No-decompression dives for 40, 50, and 60 FSW have been calculated and included in the tables.

c. Long duration, variable depth diving, is the normal operational mode. Decompression diving is the normal mode.

d. The depth limit is 150 FSW.

e. A recompression chamber and medical officer are not required to be on site as a prerequisite to MK 15 UBA diving operations. However, appropriate notification should be made of diving operations to nearest chamber in accordance with Volume 1, Chapter 4.

f. Training should emphasize control of depth, control of ascent rates and decompression diving. The diver is independent of surface support.

The underwater decompression computer is the preferred means for determining decompression requirements when diving with the MK 15 UBA. For training purposes and/or when the UDC is otherwise unavailable, limited diving operations may be carried out using the MK 15 Decompression Tables.

Preferred procedures for both training and operational use of the MK 15 involve decompression. Development of a diver's ability to carefully control his rate of ascent at 60 feet per minute or less and to carefully maintain his depth during decompression stops is considered an important goal in training. These are essential skills for qualified MK 15 UBA divers. Although "No Decompression" diving is possible at shallow depths, and for brief dives to greater depths, the routine use of appropriate decompression dive profiles is encouraged.

When diving with open-circuit scuba, oxygen partial pressure increases as depth increases. Since the MK 15 maintains the ppO_2 at a present level regardless of depth, U.S. Navy standard air decompression tables cannot be used. MK 15 decompression tables using a setpoint level of 0.7 ATM of oxygen partial pressure, are based upon extensive experimentation and current experience.

CHAPTER TWELVE

SURFACE-SUPPLIED MIXED-GAS DIVING OPERATIONS



Figure 12-1 Divers wearing He-O₂ recirculating deep-sea outfit

Surface-supplied, mixed-gas diving involves those forms of diving in which a breathing mixture other than air is supplied from the surface to the diver by a flexible hose. This method of mixed-gas diving is particularly suited for operations beyond the depth limits of air diving yet of sufficiently short decompression time as to preclude the need for a Deep Diving System. Surface-supplied mixed-gas diving is also applicable in the deeper air diving range when the operation demands freedom from narcosis to permit maximum mental acuity and manual dexterity.

As with surface-supplied air diving, the mixed-gas diver has a choice of two basic outfits—**heavyweight** and **lightweight**. The factors which influence the choice of equipment are much the same as for air diving: nature of the work to be accomplished, diver comfort and protection, environmental considerations, and availability of support facilities.

The heavyweight outfits; the MK 12 surface supported and the MK 5 MOD 1 He-O₂ Recirculating Helmet deep-sea rig; and the lightweight outfit, employing the Diver's Mask USN MK 1 from an open bell, will be described in detail. Other material covered in this chapter includes the operation of mixed-gas supply systems, diver communications, and underwater techniques and procedures which are unique to mixed-gas operations.

SURFACE-SUPPLIED MIXED-GAS DIVING OPERATIONS

DIVING EQUIPMENT 12.1

MK 5 Deep-Sea Mixed-Gas (He-O₂) Outfit 12.1.1

The heavyweight mixed-gas outfit is a modified deep-sea air outfit. The diving dress, umbilical and accessories are identical in most respects; but the helmet has been reworked to provide for the installation of a gas recirculating system. This helps to conserve the breathing mixture by passing it through a carbon dioxide absorbent and thus reduces the need for large volumes of fresh mixture for ventilation of the helmet.

Conservation of gas is important primarily because of the expense and supply problems involved in obtaining and handling helium-oxygen mixtures. Early experiments with these mixtures, conducted with standard deep-sea helmets, demonstrated the feasibility of helium-oxygen diving. However, adequate ventilation of the helmet and dress required a constant flow of at least three cubic feet per minute measured at the depth of the diver. At a depth of 297 feet (10 atm abs), for example, the necessary flow measured at the surface is 10 x 3 or 30 cubic feet per minute. At that rate an average cylinder of gas would only last about 7 minutes.



Figure 12-2 Front and rear views of divers wearing recirculating deep-sea outfits.

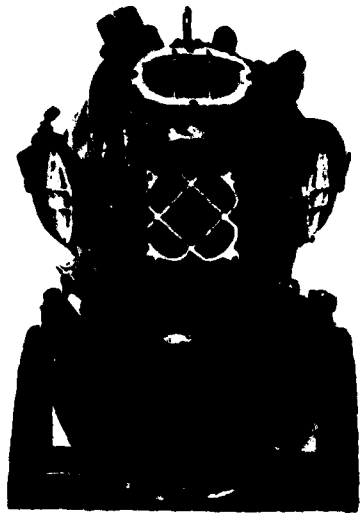

Figure 12-4 Recirculating helmet; front view



Figure 12-5 Recirculating helmet; rear view

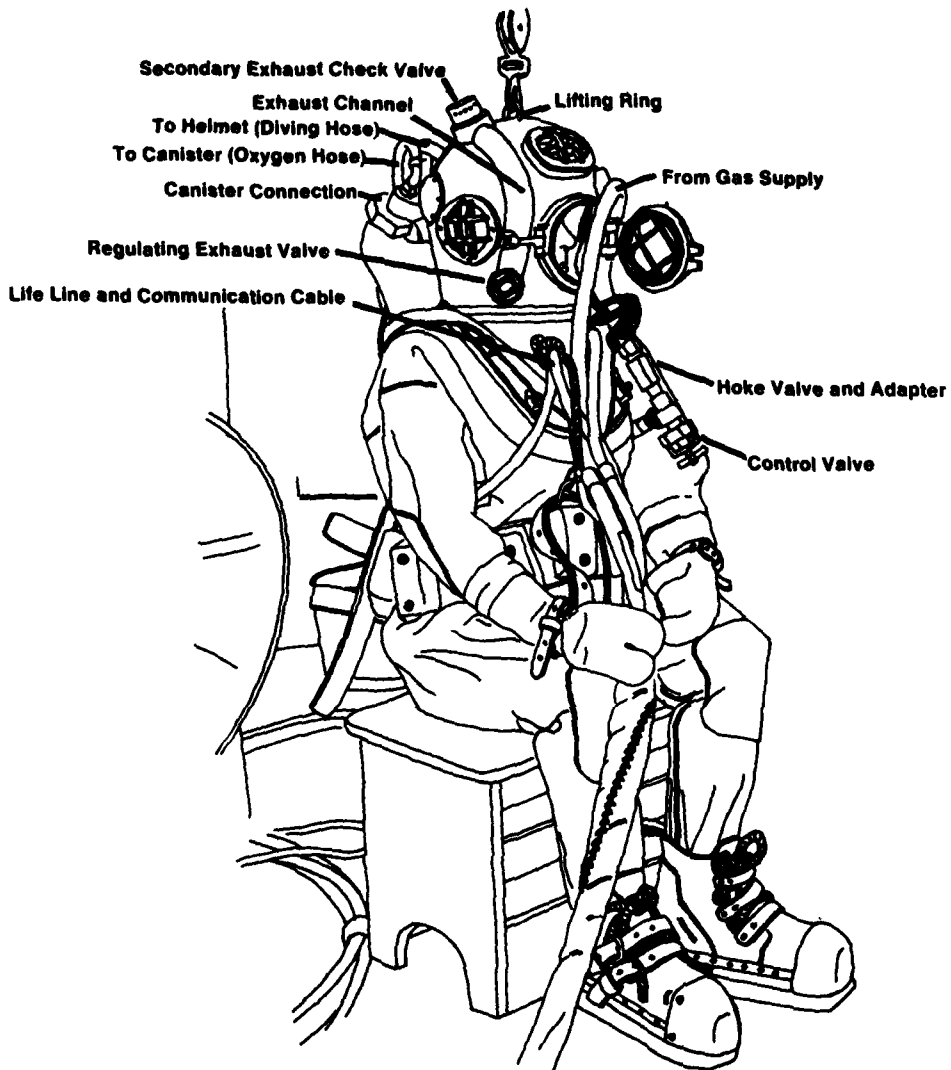

Figure 12-3 USN MK 5 MOD 1 HE-O₂ Recirculating Outfit

A working diver on the bottom actually needs only about 0.5 cubic foot of make-up gas (measured at depth). After some experimentation with various apparatus, most of which proved to be too clumsy or inconvenient to use, the design evolved to a simple modification of the Mark 5 helmet which has proven to be both safe and efficient.

For purposes of discussion and comparison with standard deep-sea equipment, the components of the heavyweight mixed-gas outfit are divided into four groups—

Helmet Group—which includes the helmet, breastplate, recirculating system, and associated valves and fittings.

Diving Dress Group—which includes the basic dress, underwear, chaffing pants, helmet cushion, gloves, shoes, weight belt and diver's knife.

Hose Group—which includes the gas supply hose and fittings, and control valve, the lifeline and amplifier cable, and the pneumofathometer.

Maintenance Tools and Spare Group—special tools and spare parts required for the deep-sea outfit.

THE HELMET GROUP 12.1.1.1 The He-O₂ helmet is a modified standard Mark 5 air helmet; it is constructed of the same materials and is similar in most respects with the following exceptions—

- two large goosenecks have been installed on the rear of the helmet. These provide the connections for the recirculating device and carbon dioxide absorbent canister.
- a smaller gooseneck is located at top rear center of the helmet. This connection originally permitted the use of a set of electrically-heated underwear which is no longer employed. The gooseneck is now sealed.
- a secondary exhaust check valve has been installed on the exhaust channel to prevent accidental flooding.
- a special internal duct leading from the canister discharge opening provides improved gas circulation within the helmet.

—because the canister fits up against the rear neck portion of the helmet, the safety lock (dumbbell) has been relocated to the position formerly occupied by the spitcock. The spitcock itself has been removed as an additional safeguard against the loss of breathing mixture and flooding.

—the breastplate has been modified for the change in position of the safety lock; otherwise, it is unchanged.

The modified helmet with breastplate and canister weighs approximately 103 pounds. This compares with 56 pounds for the standard helmet and breastplate and obviously poses an extra burden on the diver and tenders. As an aid in handling the unit, a lifting ring has been attached at the top of the helmet. The ring is used in conjunction with a small block and tackle, and it is of particular value when lowering the helmet over the diver's head and holding the weight off his shoulders during the dressing process.

CAUTION

Under no circumstances must this ring be used to lift the diver

The recirculating system consists of a gas supply, a circulating device which operates on the venturi principle, and a canister of carbon dioxide absorbent.

The gas supply is taken from the main supply hose just ahead of the control valve. A Hoke valve is installed on a special adapter on the inlet side of the control valve. When the Hoke valve is open, gas is passed through a 54-inch section of standard oxygen hose and into the recirculating device installed in the right-hand canister gooseneck. The Hoke valve and the main control valve operate independently of each other—either or both may be used at any given time. In normal operation the Hoke valve is never closed unless the recirculator malfunctions or the supply hose breaks or becomes disconnected. The control valve is usually kept closed except under the following conditions—

- to build up the pressure and volume of gas in the suit during descent.
- whenever the diver needs a sudden increase in gas in the suit to regulate buoyancy.

- to supply breathing mixture to the helmet in a conventional "open-circuit" mode in the event the recirculating system should fail.
- to ventilate the dress by flushing out the gas with a fresh supply.

These procedures are described in Section 12.3.1.3. The recirculating device, or aspirator, contains a high-pressure injector nozzle of a size calculated to provide, at 100 psi over ambient pressure, a volume of gas that contains sufficient oxygen to replace that consumed by the diver. This jet of incoming gas also performs the work of recirculating the gas within the helmet through the absorbent canister. Recirculation is accomplished by a well-known principle (Venturi's) by which a rapidly moving jet of gas tends to drag surrounding gases along with it and thus create a suction-pump effect. The Venturi nozzle draws 11 times its own input volume (0.5 cu. ft./min. at the pressure of the dive) of "used" gas through a passage from the interior of the helmet. This carbon dioxide laden gas, now combined with incoming fresh gas, passes through the chemical absorbent in the canister and the carbon dioxide is removed. The mixed gases then pass into the helmet; any excess gas pressure that builds up is released through the exhaust valve.

The aspirator assembly includes a screen retainer assembly, a high-pressure nozzle, an aspirator body with a passage from the interior of the helmet, and a Venturi discharge nozzle (Fig. No. 12-6).

The screen retainer assembly holds a 100-mesh bronze screen which prevents the high-pressure nozzle from becoming plugged by foreign matter which may be blown through the hoses. This screen must be inspected and cleaned before each dive. The screen retainer assembly screws directly into the high-pressure nozzle fitting. The nozzle fitting screws directly into the aspirator body with a metal-to-metal seal in which no packing is used. The nozzle fitting may be removed for cleaning with a 3/4-inch wrench.

The nozzles are machined to close tolerances and must be handled very carefully. A nearly invisible scratch or a small bit of foreign matter will alter the flow of gas and may result in inadequate ventilation

of the helmet. The nozzles should be inspected before each dive.

The high-pressure injector nozzle should be cleaned and checked for proper size by first blowing filtered high-pressure air through the nozzle, and then by running a wooden or plastic rod, the size of a No. 72 drill, through the nozzle from the high-pressure side. In normal practice the shank of a No. 72 drill (held inverted in a pin vise) is often used; however, the drill-end must never be used since this would scratch the nozzle surfaces.

The Venturi discharge nozzle is screwed into the lower side of the aspirator body and projects down into the canister. It can be removed with a 7/8-inch wrench.

The discharge end of the canister is fitted with a 20 mesh screen to prevent particles of the absorbent from being carried into the helmet. The canister itself is secured to the two goosenecks with 3-inch lock nuts containing Koroseal or neoprene washers to ensure a watertight connection. Water leaking into the canister seriously reduces the effectiveness of the CO₂ absorbent.

A fully-packed canister, which holds approximately 6 pounds of absorbent, has a maximum duration of 3

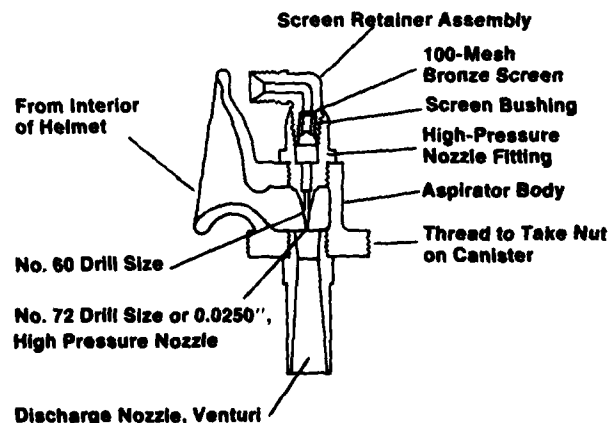

Figure 12-6 Recirculating device

hours (with a 200-percent safety factor) under average diving conditions. When diving in cold water conditions (40°F or less), however, the chemical reaction is not as effective and duration may be reduced to as low as 35 minutes. Additional operational procedures which must be followed when using absorbent are—

- maintain a 100-psi overbottom mixed-gas pressure for all working dives.
- special periods of manual ventilation should be a regular part of working procedure.

WARNING

The CO₂ absorbent contains an “indicator” chemical intended to demonstrate the extent of absorption by a color change. This is an inaccurate indicator and should be disregarded.

Three valves are installed on the helmet. These are the safety non-return valve, the gas-regulating

exhaust valve, and the secondary exhaust check valve. The non-return valve may be of either the cartridge/O-ring or spring stem type; and, as in air diving equipment, it is mounted on the inlet gooseneck. The presence of this valve is mandatory, and proper functioning must always be checked prior to commencing the day's diving. The exhaust valve is the same unit used in air diving with the exception that the valve is adjusted so that the initial setting has the spring follower disk in contact with the sleeve when the adjusting wheel is 2 1/2 turns short of the fully closed position. (This compares with a setting of 1/8 turn for air diving operations.)

The secondary exhaust valve, which is not part of the standard Mark V outfit, is a double-check valve installed at the end of the exterior exhaust channel to guard against the possibility of accidental flooding. This valve should be disassembled prior to each dive and inspected for tightness and cleanliness. Both rings are tightened by hand. Special spanner wrenches may have to be used to disassemble the rings for inspection.

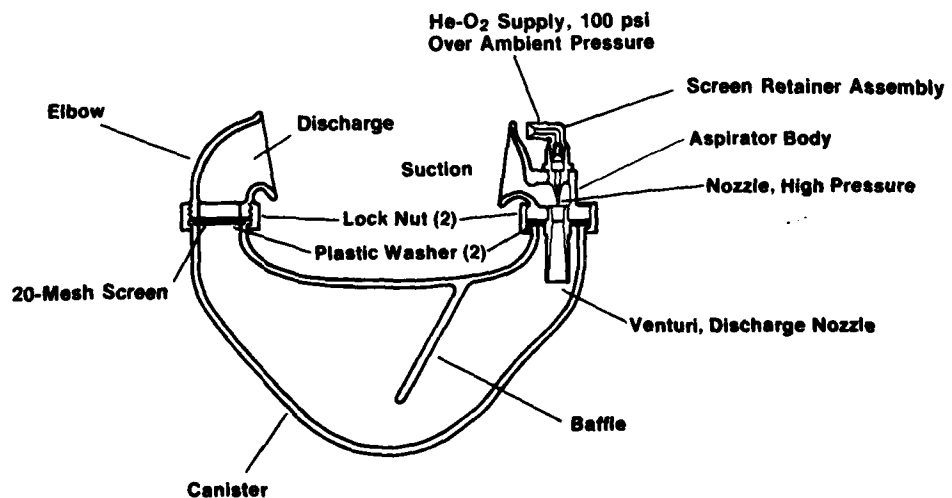

Figure 12-7 Canister assembly; sectional view

THE DIVING DRESS GROUP 12.1.1.2 The diving dress used in mixed-gas diving is virtually identical to that used in air diving. The only basic difference is the shoes, which are standard deep-sea shoes which have been modified to weigh 35 to 40 pounds each. The modification is accomplished by adding a second standard lead sole to the shoe, or a special lead sole weighing approximately 35 pounds. These special soles are not available through the supply system, and should be made from molds constructed by the diving activity. Diving gloves are always worn to guard against gas leakage.

THE HOSE GROUP 12.1.1.3 The basic hose group is essentially identical to that used in air diving. The primary difference is that a special adapter is fitted to the air control valve to permit attachment of

the Hoke valve and special length of hose leading to the screen retainer assembly.

MAINTENANCE TOOLS AND SPARES GROUP

12.1.1.4 Although the majority of mixed-gas diving equipment, like that used in air diving, can be serviced and maintained with commonly available handtools, the He-O₂ deep-sea outfit requires special tools. These tools must be available at the operations site and include such items as special wrenches for the secondary exhaust valve on the hard hat and No. 72 drill-sized rods (or drills) for checking the aspirator nozzle. Spare parts such as spare washers, 100-mesh screens for the aspirator and 20-mesh screens for the canister must also be available. A list of such items is contained in Table No. 12-1.

TABLE 12-1—MIXED-GAS EQUIPMENT TOOLS, MAINTENANCE ITEMS AND SPARE PARTS

COMPONENT	QUANTITY	COMPONENT	QUANTITY
Tools		Spare Parts (cont.)	
Box, tool and spare parts	2	Gasket, secondary exhaust valve	3
Die, rethreading 1/2 in.-12	2	Glass, helmet, face window	6
Die, rethreading 1 1/16 in.-17	2	Glass, helmet, side window	6
Tap, rethreading 1/2 in.-12 N	2	Glass, helmet, top window	6
Tap, rethreading 1 1/16 in.-17 NS	2	Nozzle, discharge, venturi	3
Wrench, nonreturn valve	4	Nozzle, high pressure	3
Wrench, open end, oxygen hose	6	Nut, wing, breastplate (flanged)	15
Wrench, open end, air hose	6	Nut, wing, breastplate	30
Wrench, open end, amplifier & lifeline coupling	6	Screw, machine, brass 8-32 NC x 3/8 in., gross	1
Wrench, spanner, diving cable	6	Screws, rubber valves	6
Wrench, T-slot, helmet	6	Springs, exhaust valve, pair	12
Maintenance Items		Stud, breastplate (long)	6
Cement, rubber, quarts	12	Stud, breastplate (short)	18
Cloth, patching diver's dress, yards	4	Valve, exhaust, secondary	1
Halyard, signal cord, cotton, feet	20	Valve, Hoke	5
Packing, air control, flax, feet	100	Valve, rubber, flapper	6
Sealing compound, beeswax, pounds	10	Washer, air hose, leather	50
Tubing, elastic, yards	20	Washer, amplifier	50
Spare Parts		Washer, copper, for breastplate straps	50
Drill, No. 72	3	Washer, nonreturn valve seat	20
Gasket, faceplate	6	Vice, pin, No. 72 drill	1
Gasket, helmet, leather	10		

MIXED-GAS SUPPLY 12.2

The basic mixed-gas supply system (rack), as installed on ASR-type vessels, was described in Chapter Ten. Units may vary in design and some details from one installation to another, but each serves the same purpose: to provide the diver with appropriate breathing media (including mixed gas, air and oxygen) as needed during the dive and decompression profile. Operation of the gas rack requires special training. Under no circumstances should inexperienced personnel be allowed to operate the rack during preparation for, or execution of, a dive.

Appendix C Diving Gases, provides necessary data on purity standards, mixing procedures and gas analysis and also discusses safety precautions which should be thoroughly understood by all diving personnel engaged in mixed-gas operations. Prior to commencement of operations, however, the following general items should be verified—

Alternate Supplies—Two independent mixed-gas supplies of an appropriate mixture for the dive to be undertaken should be available at the diving station for immediate switchover in the event of failure of one supply.

Other Gases—Breathing air for emergency use during the dive (Chapter Fifteen) and oxygen for use during decompression should be available at the diving station and supplied to the manifold in such a manner as to permit immediate transfer of the diver to the alternate breathing medium.

Gas Quantity—Sufficient mixed gas must be stored in the primary supply to—

- A. satisfy the apparatus demand of the working diver throughout the bottom and decompression phases of the dive,
- B. support the standby diver in an emergency,
- C. provide a reasonable contingency.

The alternate supply must be capable of supporting a diver and standby diver during the total decompression phase of the dive. 100% oxygen, and air must also be available to supply breathing and ventilation requirements in the recompression chamber for treatment of decompression sickness.

Oxygen Percentage—The oxygen content of the mixed gas must be carefully selected and specified for the depth and bottom time of the dives to be undertaken. Oxygen percentage must be within normal tolerance limits to preclude the hazard of oxygen poisoning (Chapter Fifteen). Whether procured as specific mixes from the supply system or mixed by diving personnel, all cylinders of mixed gas must be analyzed and tagged for O₂ content prior to use (Appendix C).

DIVING PROCEDURES 12.3

Thorough planning and careful preparation is vital in all diving; however, surface-supplied mixed-gas operations, because of their increased complexity and hazards, additionally require absolute adherence to prescribed standards and procedures. Each person involved in the operation must be well trained, and his experience should be augmented by frequent exercises and emergency drills.

The comprehensive checklist presented in Appendix D should be used as a basis for preparation of a similar operational checklist which is specially suited to local conditions or unit mission parameters.

Prior to initiation of diver dressing activities, whether deep-sea or lightweight gear is to be used, the Diving Supervisor must—

1. Ensure that all equipment has been inspected and laid out including back-up and accessory gear.
2. Verify that the gas supply is correct in all respects including composition, supply pressure and flow. The primary and secondary gas supply and the standby air supply must be activated as follows:
 - A. Connect hoses to the appropriate manifolds and control stations.
 - B. Start the compressors for the standby air supply, charge the air supply volume tank, and set the system to operate at a pressure 100 psig over the maximum operating depth pressure for the scheduled dive.

- C. Select and tag the primary and secondary oxygen banks. Charge the oxygen volume tank to 125 psig. Gage and record the pressure on both banks.
- D. Select and tag the primary and secondary He-O₂ banks. Verify the proper gas percentage in both banks; check and record the pressures.
- E. Activate the mixed-gas control rack. Check percentages and pressures. Charge the He-O₂ volume tank to 54 psig for deep-sea diving; 100 psig for lightweight diving. This is the pressure at which the divers will initially be fed the gas mixture.

MK 5 He-O₂ Diving 12.3.1 Since the deep-sea He-O₂ outfit is virtually the same as the standard deep-sea outfit, many of the operating procedures are quite similar. Two dressing stations, with teams of experienced tenders, are required. Two divers should always be dressed. In contrast with air diving, both the primary and standby divers must be completely dressed including helmet installation. Since the He-O₂ helmet cannot be installed on the breastplate with the canister attached, time delay associated with proper helmet and canister placement is too long for standby safety. Consequently, the standby diver must wear the helmet with the faceplate open and be ventilated with compressed air while on deck.

CANISTER FILLING 12.3.1.1 The helmet canisters should be properly filled and be ready for installation prior to dressing the divers. The correct procedure for filling a canister is as follows—

- 1 Place the empty canister in the special filling rack.
- 2 Wash the interior of the canister with hot fresh water, paying particular attention to the canister unions, and blow dry with oil-free compressed air. Water and air hoses for this purpose should be rigged to the diving station.
- 3 Select a container of fresh USN approved CO₂ absorbent and wipe the exterior thoroughly to remove any dirt or grease before opening the container.

- 4 Pour the CO₂ absorbent directly from the container into the canister, filling the canister from both sides. A light flow of air blown over the absorbent as it is being poured will help keep some of the absorbent dust out of the canister.
- 5 DO NOT USE THE LAST TWO INCHES OF ABSORBENT IN THE CONTAINER as any dust will have settled to the bottom.
- 6 Fill the left side of the canister level with the screen rim.
- 7 Fill the right (Venturi) side to within 3 inches of the canister rim.
- 8 Tap the canister gently on deck. DO NOT SHAKE OR POUND THE CANISTER. A properly filled canister should hold approximately 6 pounds of absorbent.

DRESSING THE DIVER 12.3.1.2 The Diving Supervisor should ensure that only trained personnel will assist in dressing the divers. Inexperienced personnel, however well-meaning, can hamper the dressing procedure and possibly cause injury to the diver. Dressing procedures for He-O₂ deep-sea diving are illustrated in Figure No. 12-8.



A The helmet, suspended by a small block and tackle, is carefully lowered over the diver's head.

Figure 12-8 Fully dressed except for helmet, the special mixed-gas dressing sequence begins:



B While one tender firmly holds the breastplate the other turns the helmet until it is securely mated to the breastplate.

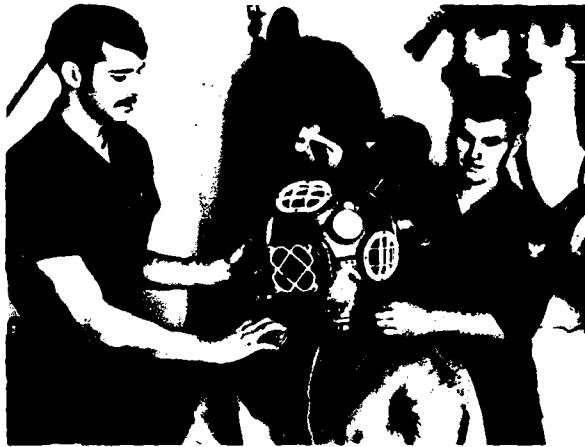

C The safety lock is turned down into the breastplate recess and secured by the latch and cotter pin.
Note: Test the communications system.



D The life-line/communications cable and diving hose are positioned and secured, the control valve assembly having been mated with the Hoke valve adapter. The pneumofathometer is positioned with the discharge at chest level.



E The recirculating device is set into the right-hand canister gooseneck and screwed down hand tight.



F A Koroseal or neoprene washer is placed in the right-hand canister nut and a 20 mesh screen (smooth side up) and Koroseal or neoprene washer placed in the left-hand nut.



G The canister is positioned and the canister nuts are hand tightened. Using special wrenches, the tenders evenly and firmly tighten the nuts, alternately taking up on each one.

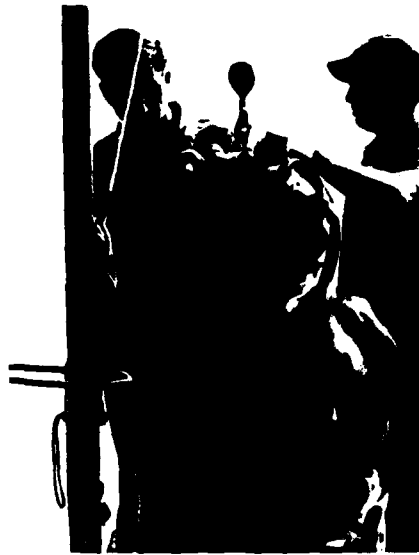

H Fully dressed diver ready for pre-dive check procedures.

Note: The Diving Supervisor should verify that the canister is properly installed and check all other connections. When satisfied, he calls for "gas on diver" and the Rack Operator sends He-O₂ to the diver at the pre-set pressure of 54 psig.



J Faceplate closed, the diver is pressurized using the control valve until the secondary exhaust valve just lifts. Close the control valve.



I A tender puts his hand inside the helmet to deflect the initial gas flow and the Hoke valve is fully opened to blow absorbent dust out of the canister.

Note: When the gas passing through the canister remains clean, the faceplate is closed and the diver breathes deeply for a few seconds. The faceplate is opened, and the diver counts out loud. If his voice exhibits the "Donald Duck" effect, this verifies that he is on HeO₂.



K Tenders soap all suit connections and seams from top to bottom of the diver to detect any leaks.

Note: The diver should personally check the setting and operation of all valves and should fully ventilate. When satisfied that his equipment is operating properly he signals his readiness for the dive to the tenders by both the communications system and hand signal.



L The tenders make a final check of the equipment and signal the diver to stand up by patting the top of the helmet.



M Assisted by tenders, the diver moves onto the diving stage and is ready to be lowered into the water.

IN-WATER PROCEDURES 12.3.1.3 The basic in-water procedures used in hard-hat diving with air are also followed in mixed-gas diving. As previously discussed, environmental factors are likely to be more pronounced, and the diver must be prepared—both physically and psychologically—to cope with these factors.

The basic difference in underwater procedures between air and He-O₂ deep-sea diving is that the diver is on semi-closed circuit utilizing the recirculating system to conserve the gas supply. This is the normal mode of operation for He-O₂ diving, but in order to ensure adequate ventilation in the diving dress, the diver must change modes from time to time. Two special hand signals have been established by which the diver can be directed to switch, and by which he can inform topside personnel of his status in the event of failure of phone communications. These signals are—

3 and 2 pulls: "Ventilate" or "Go on open circuit."

4 and 3 pulls: "Circulate."

Gas Flow Control

To ventilate, the diver opens his control valve about one-quarter turn and holds the chin button depressed. He should ventilate whenever directed to do so, whenever he is not satisfied with the efficiency of the recirculating system, and whenever he wants to completely flush out and renew the atmosphere in the diving dress. When performing heavy work, the diver should ventilate at regular intervals to compensate for his increased production of carbon dioxide and to ensure that he will receive ample quantities of oxygen to support his level of effort. Ventilation is also used to facilitate the change-over from mixed gas to oxygen during decompression.

To circulate, the diver closes his control valve and releases the chin button. The breathing mixture will then pass through the Hoke valve, and the recirculating system will be in operation.

To "go on open-circuit," the diver opens the control valve and the exhaust valve and closes the Hoke valve. Open-circuit operation must be used if the recirculating system fails. The best immediate indication that the diver will have of such a problem is from the change in sound of the gas passing through the aspirator jet. When on open-circuit, the supply

system will function in the same manner as that of the deep-sea air outfit.

Descent

The diver is lowered into the water, and, with the order "COME TO 100 OVER," the gas supply pressure is brought to 100 psig over his present depth pressure. A final check is made for leaks and for proper functioning of the valves.

During descent the diver uses his control valve to keep the dress properly inflated. At the same time, the Rack Operator "leads" the descent by keeping the supply pressure 10 feet greater than the 100 psig over the diver's depth as a precaution against the pressure falling behind the diver on descent. Rate of descent is not to exceed 65 fpm.

On The Bottom

Upon reaching bottom, the diver thoroughly ventilates his dress and closes the control valve thus allowing the recirculating system to handle his supply requirements. Buoyancy will normally be controlled through the use of the chin button. The diver can open the control valve if he needs a more rapid inflation of his dress, as when moving over obstacles. The gas supply should be maintained at a constant over-bottom pressure of 100 psig.

In air diving, a fogged faceplate is considered a danger sign of potentially inadequate ventilation and associated carbon dioxide buildup in the helmet. With the recirculating helmet using mixed gas, however, the situation is reversed. Water is a natural by-product of the carbon dioxide absorbent/carbon dioxide chemical reaction, and some fogging of the faceplate can be taken as an indication that the system is working properly. However, if the diver notices a milky-white spray or liquid in the helmet, he must go on open-circuit and abort the dive. This is an indication that water has leaked into the recirculating system and has wet the CO₂ absorbent.

Preparations for ascent are the same as for air operations. Particular care must be exercised in the choice of decompression tables. The time of ascent to the first stop, time at the stops, and the depth of the first oxygen stop are all specified in the helium-oxygen partial pressure tables. An ascent rate of 60 feet per minute should be used between stops.

The gas supply pressure should be maintained at 100 psig over ambient pressure until the first oxygen stop is reached. This stop will occur at either 40 or 50 feet depending upon the decompression schedule in use. The stage should be at this stop. After the diver gets on the stage, then the gas supply is shifted to oxygen and the diver is ventilated with 25 standard cubic feet of oxygen. This measurement is readily determined by monitoring the pressure drop at the oxygen bank. A quantity of 25 scf equals a 225 psig drop from one 200 ft.³ oxygen bottle, a 112.5 psig drop from two bottles, a 75 psig drop from three bottles, etc. During this ventilation, the pressure at the oxygen volume tank should be maintained at 125 psig. Following ventilation, the pressure should be maintained at 75 psig throughout the remainder of decompression to the surface.

A more comprehensive discussion of decompression procedures—including those cases in which the diver must be decompressed using air or using He-O₂ throughout—is contained in Chapter Fifteen.

When the diver reaches the surface, the supply is immediately shifted to air and the hose is flushed out for at least one minute. In the meantime, the diver is helped to the dressing bench. The faceplate is opened, the canister removed, the lines and hoses along with the control valve are unfastened from the breastplate, and the helmet is removed.

POST DIVE PROCEDURES AND MAINTENANCE 12.4

As with any type of dive, the divers should be immediately de-briefed so that work progress can be assessed and any necessary changes to the dive plan can be incorporated. Additionally, the physical condition of the divers should be monitored to ensure that no problems have developed—or are likely to develop. The divers must remain in the vicinity of the recompression chamber for at least 1 hour following a mixed-gas dive and should not leave the general vicinity of the diving unit for at least 12 hours. Under no circumstances should a diver make a trip in an airplane for the same period; and, if emergency evacuation of a diver by helicopter should become necessary, it should be conducted at the lowest possible altitude.

Maintenance and record-keeping procedures are the same for mixed-gas as for air diving.

Following completion of deep-sea mixed-gas diving, clean and inspect washers, nozzles and fittings associated with the helmet recirculating system. These items should always be washed with fresh water and stored in a clean, dry condition. Rubber valve diaphragms in the secondary exhaust valve should be dusted with talc if they are to be stored for any period of time. One final, but important, action is to thoroughly blow all hoses clear with fresh air to ensure that no residue or oxygen remains.

LIGHTWEIGHT MIXED-GAS DIVING OUTFIT (MK 1) 12.5

There are two lightweight diving masks in use in the U.S. Navy—the "Jack Browne" and the USN Diver's Mask MK 1. The Jack Browne mask is limited to use for air diving only. The MK 1 mask is an improved mask which provides two-way diver voice communications. It operates normally as a demand breathing device, and has been adapted for use in mixed-gas diving operations.

Employment of lightweight equipment for mixed-gas diving offers the advantages (over standard deep sea

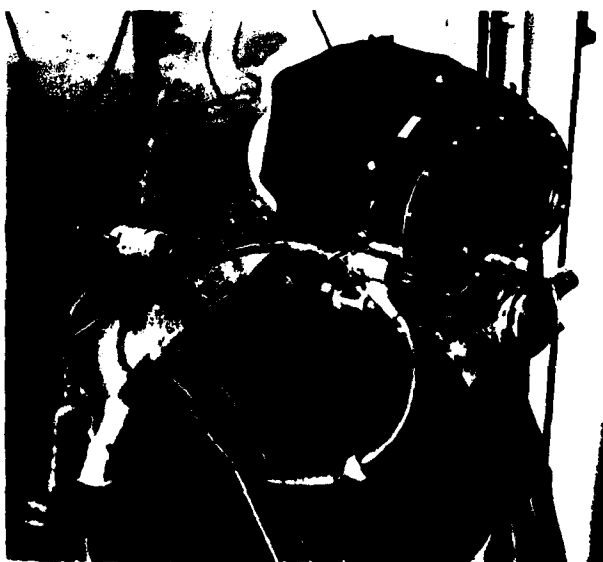

Figure 12-9 Diver dressed in lightweight mixed-gas diving outfit

equipment) of ease of operation, reduced weight, and a higher degree of mobility and flexibility. General disadvantages (for some types of operations) are that it lacks the stability and diver protection offered by the heavyweight outfit. The surface-supplied lightweight outfit may only be used for mixed-gas diving when deployed with an open bell. The bell provides a local habitat and backup facilities which significantly enhance diver safety. Only because of the additional protection afforded the diver during in-water decompression, the lightweight/open bell mode of mixed-gas diving may be conducted to depths of 300 feet.

USN Divers Mask MK 1—Which is one of the two authorized models, MOD 0 or S. MOD S is for saturation diving.

Emergency Gas Supply—Which includes bailout bottle with backpack, 1st stage regulator for bailout bottle, the diver's safety harness or IDV.

Umbilical Group—Which includes breathing gas hose, communication cable, lifeline strength member and pneumofathometer hose. Note: original procurement umbilicals used 1/2" I.D. gas hose and require a standard 30" long 3/8" I.D. leader hose to connect O₂ thread nipple on divers masks to standard Deep Sea fitting on the 1/2" I.D. gas hose.

Intercommunications Set—Which is a three diver push-to-talk unit with a helium speech unscrambling capability.

Tool Kit—Which includes minimum tools for set up of a lightweight diving station.

These items of equipment are identical with those used for lightweight air diving and are described in Section 6.1.2, Volume 1. For convenience a brief description is presented below.

NOTE

Use of the MK 12 SSDS Diving Boots in conjunction with the lightweight equipment will be permitted, where appropriate, as the MK 12 is delivered.

Diver's Mask USN MK 1—The mask is built around a molded plastic frame upon which is mounted a rubber



Figure 12-10 USN Diver's Mask MK 1

face seal, a head harness, an acrylic plastic faceplate and the gas control devices. A moveable nose pad on the interior of the mask can be used by the diver as an aid in clearing his ears and sinuses. A communications connector couples the communications cable in the umbilical and the microphone/earphone assembly worn by the diver. The mask shall be deployed with all components correctly installed and operating; no items or components may be deleted. The approved mask configuration for surface supplied diving operations does not include a diver mounted SCUBA type first stage regulator in the umbilical system. This is not to be confused with the bailout bottle first stage regulator. The diving manifold pressure shall be 135 psi over bottom pressure for HeO₂ diving operations. This pressure is required to meet a peak flow to the diver of 12 ACFM. The average consumption rate expected during a typical dive profile is 1.4 ACFM. The components of the mask involved in the supply of breathing gas are:

- The side block assembly which distributes the flow of gas into the mask both through the steady flow "defogger" valve and through the demand regulator. The nonreturn valve is an integral part of the side block assembly.
- The demand regulator is similar to the second stage of a single hose SCUBA regulator, and provides a flow of gas into the mask as required by the divers respiration. An adjusting mechanism, commonly called the dial-a-breath,

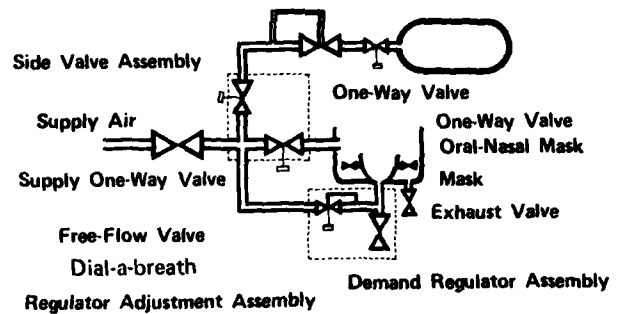

Normal Demand Breathing / Free-Flow Mode

Figure 12-11 Flow schematic, Diver's Mask USN MK 1

is provided on the demand regulator. This mechanism allows the diver to balance the demand regulator in order to minimize breathing resistance. Through the use of a manual purge button, the diver can cause a free flow of gas through the regulator.

- The emergency gas supply valve permits the attachment and use of a 72 cu. ft. back up supply cylinder of breathing gas for use in emergency situations when the normal supply is lost.
- The frame exhaust valve, located below and behind the demand regulator, also serves as a drain valve to remove water from the mask frame volume.
- The oral-nasal mask mounted inside the main body of the mask, fits over the diver's nose and mouth. The oral-nasal unit reduces respiratory dead space thereby reducing the possibility of carbon dioxide buildup.

The emergency gas supply, or "bail-out" bottle, must be worn on all mixed-gas dives employing lightweight equipment. This supply includes a standard SCUBA 72 cubic foot cylinder, harness assembly and first stage regulator. The bailout bottle should be filled with the HeO₂ mix that corresponds to the HeO₂ mix selected for the dive depth. The bailout bottle 1st stage regulator should be set at 135 psi over bottom pressure. In addition, a relief valve with a set pressure of 200 psig must be installed on the 1st stage regulator. A flexible medium pressure hose from the first stage regulator attaches to the emergency supply valve on the mask side block.

In an emergency involving the loss of his surface supplied gas, the diver can switch to the bail-out bottle by turning the emergency supply valve knob. Mixed-gas from the first stage regulator then passes directly into the side block assembly. The emergency gas may be used in either the demand or free-flow mode as necessitated by the type of emergency.

OPEN BELL 12.6

The U.S. NAVY TWO MAN OPEN DIVING BELL (also referred to as a "roving" or "pickup" bell) acts as a diving stage, simple habitat and supply point for the mixed-gas diver using lightweight equipment. While primarily designed to support the diver's Mask USN MK 1, its use need not be restricted to that system. Its concept is analogous to that of the early diving bells which provided a "captured bubble" of air for skin divers but in modern form the open bell provides numerous features unimaginable by the early pioneers in diving.

The open bell, Figure 12-12 is composed of a steel framework and an acrylic hemisphere. It is 9 feet high and 6.3 feet in diameter. The upper section of the bell is enclosed by a ½-inch thick clear acrylic hemisphere with a 26.5-inch radius, which provides an open bottom, gas tight compartment. A lift wire and umbilical line connect the bell with the surface. The umbilical provides air for the bell atmosphere, emergency breathing gas, hardwire communications and depth measurement (pneumofathometer) to the bell. Complete information on the bell, including diagrams, operation and maintenance procedures can be found in NAVSEA publication number 0994-16-8010, US NAVY TWO MAN OPEN BELL, and NAVSEA drawing number 4684707.

In operation the bell is deployed from the surface with one or two divers aboard. (In an emergency the bell can support three divers). They ride the bell in a vertical position with their head and shoulders inside the acrylic dome. During descent the divers, who wear full lightweight diving equipment connected directly to the surface, maintain a continuous flow of air into the dome to balance the increasing water pressure. Upon arrival at the bottom, either or both

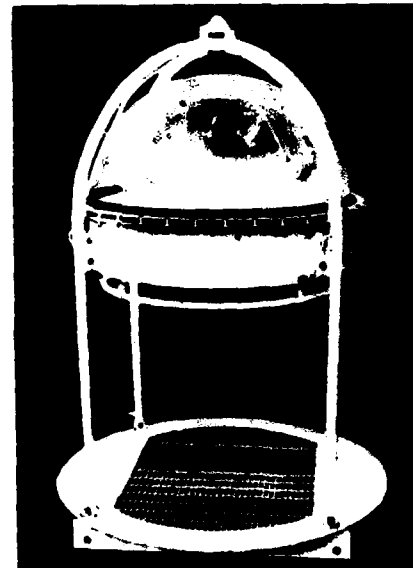

Figure 12-12 Typical open bell used in lightweight mixed-gas diving operations.

divers slip out from under the bottom skirt so their umbilicals run through the bell and proceed to the worksite, trailing their umbilicals from the bell.

Upon completion of their work the divers return to the bell and stow tools and equipment. The topside crew is advised to initiate ascent, and the bell is returned to the surface following the prescribed stage decompression procedure dictated by depth, gas mixture and bottom time.

The open bell provides several advantages which enhance diver safety and permit the use of lightweight diving techniques for deep, mixed-gas, surface-supplied diving. Advantages include—

- Simple Deployment—Virtually any naval ship that has suitable equipment to support mixed-gas diving can be used as a surface platform. The need for a large deck area, heavy lift capability, and an extensive topside crew associated with DDS-type operations is eliminated. If the ship can support conventional surface-supplied recirculating He-O₂ helmet diving, it can provide suitable facilities to support lightweight-equipped mixed-gas divers.
- Diver Mobility—The lightweight mode of mixed-gas diving permits maximum diver mobility in horizontal and vertical attitudes as previously discussed.

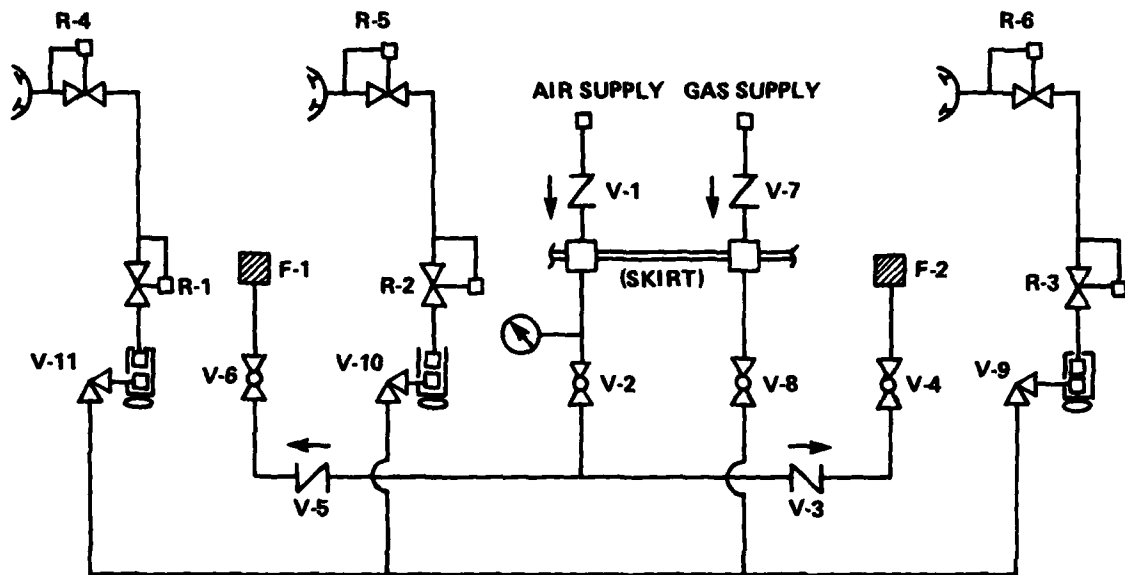

V-1	Air Supply Non-Return Valve, Bell Interior	V-8	Primary Gas Shutoff Valve, for regulators	R-1	1st Stage Regulator 1
V-2	Air Supply Primary shutoff valve, Bell Interior	V-9	BIBS Station 3 Shutoff Valve	R-2	1st Stage Regulator 2
V-3	Check Valve	V-10	BIBS Station 2 Shutoff Valve	R-3	1st Stage Regulator 3
V-4	Air Shutoff Valve	V-11	BIBS Station 1 Shutoff Valve	R-4	Second Stage Regulator 1
V-5	Check Valve			R-5	Second Stage Regulator 2
V-6	Air Shutoff Valve	F-1	Diffusers, Bell Interior	R-6	Second Stage Regulator 3
V-7	Air/Mixed gas Supply Non-Return Valve, for regulators	F-2	Diffusers, Bell Interior		
		GA-1	Air Supply Overbottom Pressure Gage		

Figure 12-13 Gas System Schematic.

- **Refuge and Comfort** — In the event of equipment malfunction or injury, the diver is never more than a short distance from the safety of a breathable atmosphere. The dry environment surrounding his head and shoulders also provides the diver a measure of comfort during the decompression phase of the dive.
- **Alternate Communications** — In the event of a malfunction of the communications set within the MK 1 mask, the diver may remove the mask within the compartment and communicate with the surface via the reproducer in the bell.
- **Auxiliary Equipment** — The open bell provides a light weight platform convenient to the work-

site for storage of tools, lights and other equipment required to conduct various tasks.

- **Emergency Gas Supply** — Three BIBS Masks are installed in the bell for emergency backup of the diver's primary mixed-gas supply.

ACCESSORY EQUIPMENT FOR MIXED-GAS DIVING 12.7

For the most part, the accessory equipment used in deep-sea and lightweight air diving operations is appropriate for use in comparable mixed-gas operations. Environmental factors (such as the colder waters normally encountered in deep diving and the additional

temperature problems caused by the high thermal conductivity of helium mixtures) will frequently determine the specific choice of accessory equipment. Additionally, because mixed-gas operations are more complex and require greater levels of surface support, the types and quantities of accessory equipment required must be carefully considered during the planning phase of the operation.

Hot Water Suit 12.7.1 Surface-supplied mixed-gas diving employing lightweight equipment often requires that supplementary heat be supplied to the diver. Cold water diving and protracted in-water decompression from deep and/or long bottom time exposures causes a loss of more heat to the surrounding water than the body can generate. Reduction in body temperature and associated chilling effects can occur even with the most sophisticated passive insulating type suits. In order to compensate for heat loss in demanding circumstances, a hot water suit is used.

The typical hot water suit, shown in Fig. No. 12-14, consists of closed cell neoprene covered on the outside with a tough canvas type nylon with a softer nylon interior lining to which has been added perforated hoses along the limbs, chest, and backbone areas. Hot water, supplied by hose from the surface,



Figure 12-14 Hot water suit

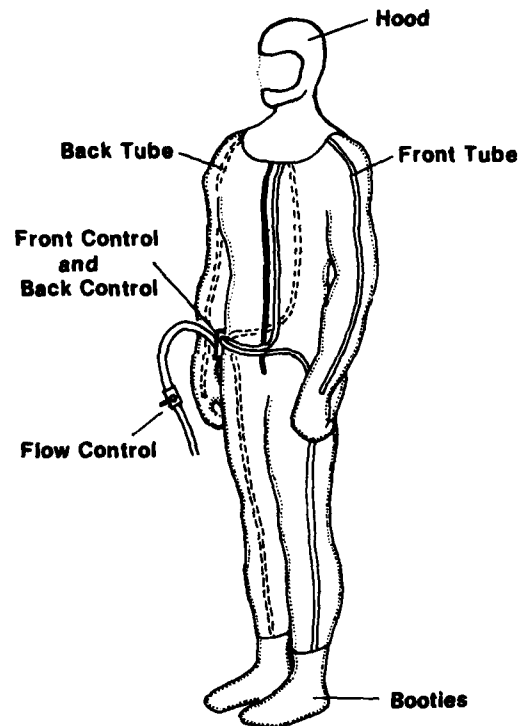

Figure 12-15 Flow schematic, hot water suit

enters the suit through a control manifold at the diver's waist. Valves in the manifold permit control of the total water flow to the diver and, if desired, the split between front and back flow to suit the comfort needs of the diver. The water is discharged in the areas of greatest thermal need and then flows within the suit to provide a balanced temperature. A hot water liner must be worn when using hot water suits. Suit liners prevent hot water from directly contacting the diver's body providing additional thermal protection and comfort.

For surface-supplied diving, hot water is normally generated by diesel oil-fired boilers (Figs. No. 12-16 and 12-17). Seawater is provided to the hot water generator by a self-contained pump. As it passes through the boiler it is heated to 140°F to 180°F, depending upon the generator model and thermal demand of the divers, and pumped through special hoses to the divers.

The heat lost in the transport of water through the hose is influenced by numerous factors including compo-

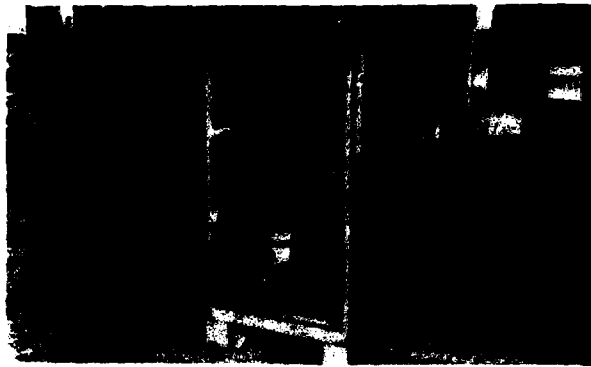

Figure 12-16 Gulf heater

sition of the hose material, rate of flow, and the temperature and circulation characteristics of the seawater surrounding the hose. Table No. 12-2 provides a chart which permits estimation of the required discharge temperature (hose inlet) from the hot water generator under various flow and hose length conditions to deliver 105°F water to a diver submerged in various temperatures of seawater. To prevent burns, water temperature must not exceed 110°F at the diver.

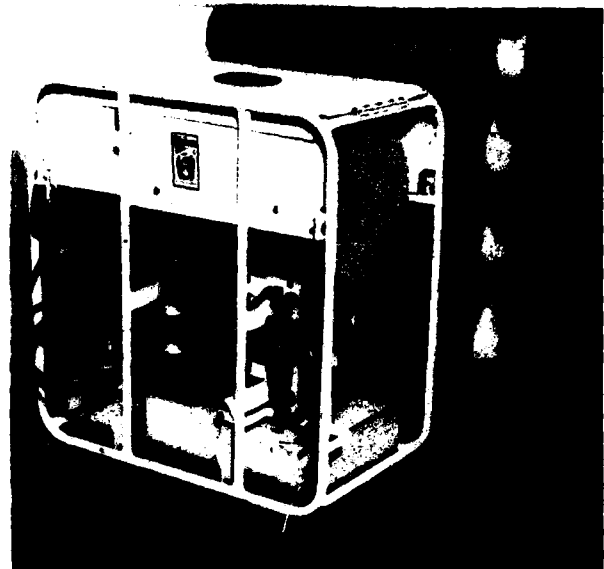

Figure 12-17 Econo heater

The boiler systems are available in several models to simultaneously support from 2 to 6 divers. The latest types of diving ships, such as the ASR 21-class, are equipped with steam-seawater heat exchangers of sufficient capacity to meet the hot water requirements of divers without the need for boilers.

TABLE 12-2—REQUIRED INLET TEMPERATURES FOR HOT WATER FLOW THROUGH 1/2-INCH I.D. HOSE DISCHARGING AT 105°F

Umbilical Length, Feet	Ambient Water Temperature, F							
	35	40	45	50	55	60	65	70
Water Flow = 2 GPM								
100	114	114	113	112	112	111	110	110
200	125	123	122	121	119	118	116	115
300	137	135	132	130	128	125	123	121
400	150	147	144	141	137	134	131	128
500	155	161	157	153	148	144	140	135
600	183	178	172	166	161	155	150	144
Water Flow = 3 GPM								
100	111	111	110	110	109	109	108	108
200	118	117	116	115	114	113	112	111
300	125	123	122	121	119	118	116	115
400	133	131	129	127	125	123	121	119
500	141	139	136	133	131	128	126	123
600	150	147	144	141	137	134	131	128
Water Flow = 4 GPM								
100	110	109	109	109	108	108	108	107
200	114	114	113	112	112	111	110	110
300	119	118	117	116	115	114	113	112
400	125	123	122	121	119	118	116	115
500	131	129	127	125	123	122	120	118
600	137	135	132	130	128	125	123	121

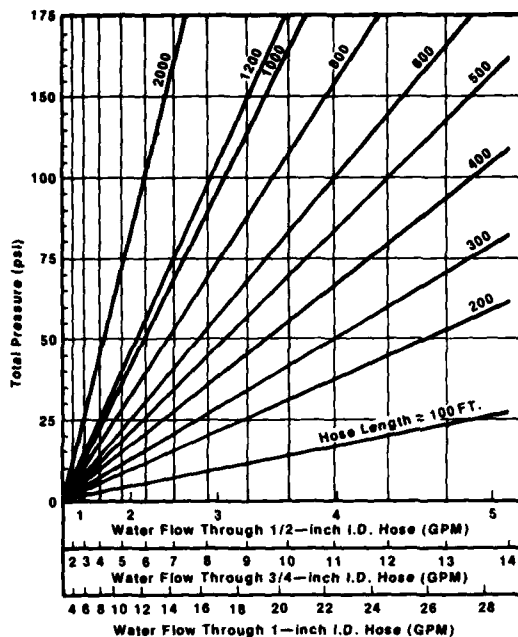

Figure 12-18 Calculated pressure loss vs. water flow rate for umbilical hoses of various diameters and lengths

Communications 12.7.2 For surface-supplied mixed-gas diving, there are two available means of communication between the diver and the surface. These are standard line-pull signals and/or voice communications established through one of the regular diving intercommunications systems.

These systems are—

- Model 1 used with the heavyweight outfit.
- Model 2 used with either the heavyweight outfit or the MK 1 mask.

Communications in mixed-gas diving are usually more difficult than in air diving for two reasons—

- If the dive is at great depth, line-pull signals are likely to be dampened out by the length and catenary of the hose and lifeline cable. This puts an extra burden on the tender to keep slack to a minimum.
- In the helium-oxygen medium, the diver's voice loses clarity (the "Donald Duck" effect previously described). This happens so quickly, in fact, that the voice change is an excellent and reliable means for verifying changes in the breathing mixture when shifting between helium-oxygen and air or oxygen. With practice and care, both the diver and the ten-

der can learn to overcome much of the difficulty in speaking and understanding. Care must also be taken to keep external factors—such as background machinery noise—to a minimum.

HELLE VOICE UNSCRAMBLER 12.7.2.1 For operating situations in which minimum voice distortion must be achieved, the Helle unscrambler communications system may be used (Fig. No. 12-19). This specially designed intercommunications unit incorporates electronic circuitry which removes the majority of voice distortion associated with helium-oxygen diving.

The Helle unscrambler is similar in function to the Model 1 diving intercommunications set. However, it has an additional control knob (graduated from 0 to 1,000) on the right front of the panel. This is adjusted by the tender to achieve minimum voice distortion. The unit employs two wires to each diver to permit three-way conversation between the surface and two divers. A built-in speaker-microphone is used for tender voice transmission and monitoring of diver conversations. A reproducer (speaker-microphone) in the diver's headgear is used for diver communications, and the Helle system will accommodate reproducers with impedances from 3 to 16 ohms.

Power is provided by an internal 12 volt lantern battery (25 hr. life), an external 12 VDC power source, or (in some models) an internal nickel-cadmium battery which can be recharged from a 120 VAC, 60 Hz source.

To operate the system, the tender volume control switch is turned to the ON position, and the diver's and tender's volume knobs are adjusted to the desired level. The operator must hold the "press-to-talk" lever down while talking and release it when listening. He may listen or talk to both divers simultaneously by turning the "divers' speakers switch" to the BOTH position. To talk to one diver alone, he selects the appropriate position for diver one or diver two. When one diver would like to talk to the other diver, he must tell the operator who then presses the appropriate cross-talk switch. These are momentary switches which must be alternately held down by the operator while the divers are conversing. The tender volume control knob controls the volume between the two divers when the cross-talk switches are being used. The operator can hear the complete conversation at all times, and he may interrupt at any time by using the "press-to-talk" lever.

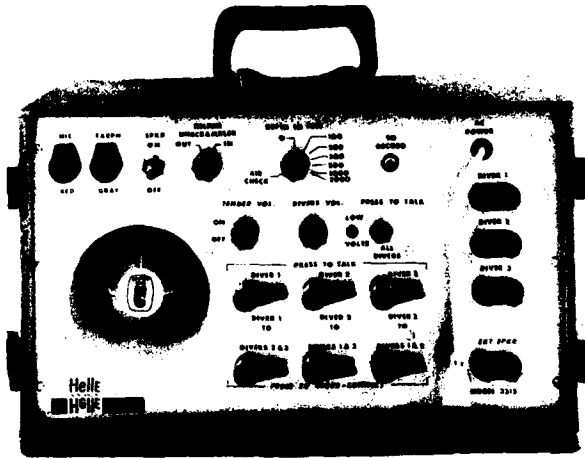

Figure 12-19 Model 3315 Helle Helium-Voice Unscrambler

MK 12 SURFACE SUPPORTED MIXED-GAS DIVING SYSTEM 12.8

The MK 12 mixed gas diving system uses the same basic equipment as the MK 12 air diving system, plus a modular recirculator, which is connected to the diver's jocking harness and attached to the helmet with flexible hoses.

The MK 12 helmet is set up in accordance with the procedures stated in Volume I of this manual for air diving, except the one way valves in the mixed gas adapters are placed so that they open in the direction of gas flow. (Gas flows to the helmet on the right, and out on the left).

The recirculator assembly supplies 0.5 ACFM of surface supplied gas through an injector nozzle (0.028 in. in diameter) to the helmet and recirculates an additional 6 ACFM through the helmet. The canister holds 12 pounds of USN approved CO₂ absorbent and has

a duration of 9 hours in 40°F (4°C) water if supplied with hot water. When diving in water temperatures above 50°F (10°C), hot water is not needed. The emergency bottle holds 27 cubic feet of gas when charged to 2250 psig. The bottle can supply the diver with emergency gas for 8 minutes at 300 FSW on semiclosed circuit.

Diving Procedures 12.8.1 Diving procedures with the MK 12 are basically the same as those for the MK 5, with the following exceptions:

A. The diver's gas supply pressure shall be provided in accordance with Table No. 12-3. Keep pressure 10 FSW ahead of the diver's depth during descent and even with the diver's depth while on the bottom and during ascent.

B. The helmet exhaust valve shall be shut during descent to prevent having to add gas through the supply valve. Upon reaching the bottom, the diver can adjust the exhaust valve for his own comfort or required buoyancy.

C. The helmet supply valve shall remain shut, except to add gas during descent and for ventilation at oxygen stops. The valve is also opened for emergencies when the recirculator fails to work properly (It is not necessary to routinely ventilate the diver as with the MK 5).

D. To ventilate the diver with oxygen at 50 ft, the supply pressure shall be raised to 135 psig (125 psig when the first stop is 40 feet). Supply pressure shall be allowed to drop to normal when venting is complete.

For detailed information on MK 12 diving procedures, refer to the MK 12 operations and maintenance manual (NAVSEA-0994-LI-018-5010).

TABLE 12-3—MIXED GAS FLOW PARAMETERS

DEPTH (FSW)	CONSOLE PRESSURE PSIG*	OVERBOTTOM PRESSURE PSIG*	CONSUMPTION ACFM	GAS MIX He-O₂ (%)
0	19	18	0.7	84/16
20	32	21	0.7	84/16
40	42	23	0.6	84/16
60	57	29	0.5	84/16
80	71	35	0.5	84/16
100	82	37	0.5	84/16
120	92	38	0.4	84/16
140	103	40	0.4	84/16
160	116	44	0.4	84/16
180	125	44	0.4	84/16
200	135	45	0.4	84/16
220	146	47	0.4	84/16
240	157	49	0.4	84/16
250	162	50	0.4	84/16
260	168	51	0.4	84/16
280	177	52	0.4	84/16
300	188	54	0.4	84/16
320	199	56	0.4	84/16
340	211	59	0.4	84/16
360	223	62	0.4	84/16
380	235	65	0.4	84/16

*For 6 ACFM System Flow round off all pressures to the next higher number.

Diving Supervisor's Checklist 12.8.2 The MK 12 Supervisor shall check the following items prior to the dive.

1. Check mixed-gas one-way valves for proper installation.
2. Check emergency bottle pressure.
3. Ensure emergency bottle valve is off.
4. Ensure ejector supply valve is open.
5. Check for flow of gas supply to rig.
6. Check hat on the diver.
7. Check locking pin.
8. Ensure recirculator hoses are connected.
9. Ensure open circuit whip is connected.
10. Have diver check open circuit flow.
11. Ensure strain relief is connected.
12. Leak check divers in water.



Figure 12-20 Mixed Gas Configuration

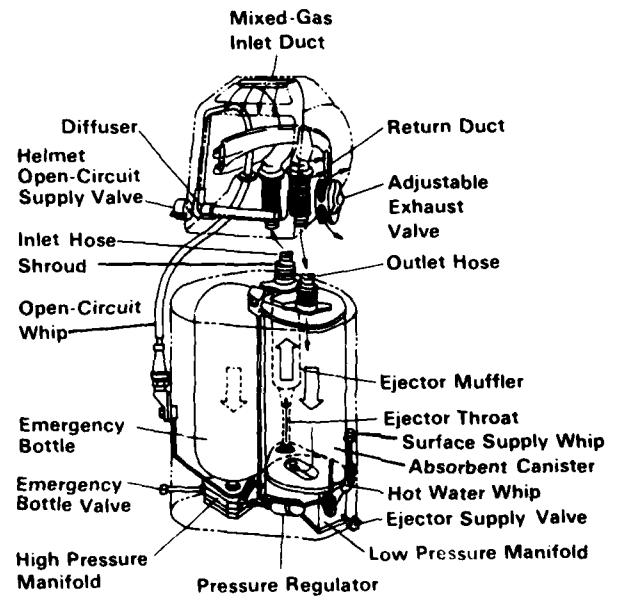

Figure 12-21 Mixed Gas System Flow, Semi-closed

AD-A112 710

NAVAL SEA SYSTEMS COMMAND WASHINGTON DC F/G 13/10
U S NAVY DIVING MANUAL. VOLUME 2. MIXED-GAS DIVING. REVISION 1.(U)
JUL 81

UNCLASSIFIED

NAVSEA-0994-LP-001-9020-2

NL

2-3

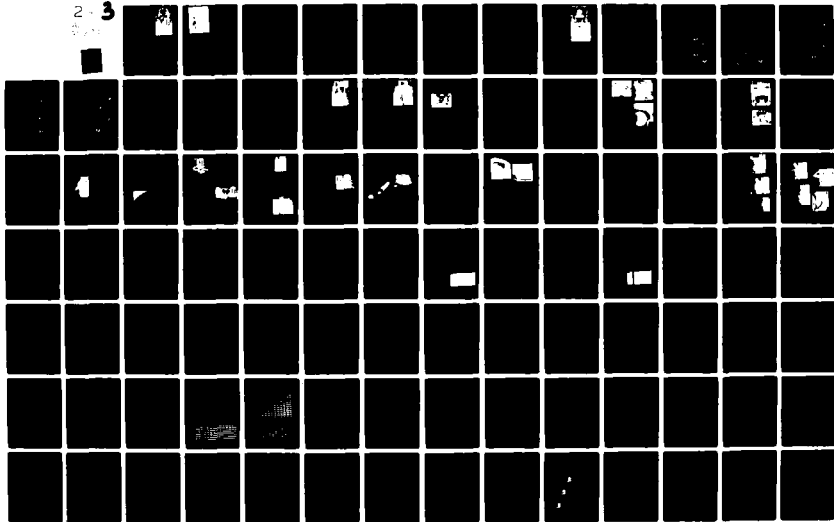

2 OF 3

AD

A112710

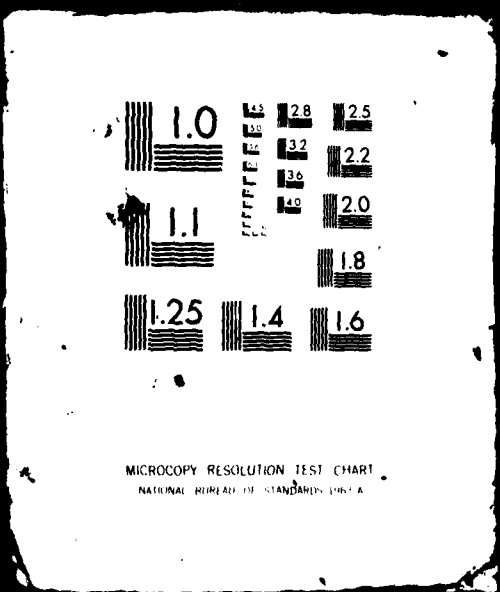

CHAPTER THIRTEEN

DEEP DIVING SYSTEMS

Although open, pressure-balanced diving bells have been in use for several centuries, it was not until 1928 that a bell appeared which was capable of retaining internal pressure when raised to the surface. In that year Sir Robert H. Davis, the British pioneer in diving equipment, designed the Davis Submersible Decompression Chamber (SDC). The vessel was conceived as a method of reducing the time a diver would be required to remain in the water during a lengthy decompression.

The Davis SDC consisted of a steel cylinder with two inward opening hatches, one on top and one on the bottom, capable of holding two men. In operation the surface-supplied diver was deployed over the side in the normal mode, and the bell was lowered with a tender inside to a depth of 60 feet with the lower hatch open. Surface-supplied air was used to ventilate the bell and to prevent flooding. The diver's deep decompression stops were taken in the water, and upon arrival at 60 feet he was assisted into the bell by the tender. The diver's gas supply hose and communications cable were removed from the helmet and passed out of the bell. The lower door was closed, and the bell was lifted to the deck. The diver and tender in the bell were subsequently decompressed within the safety and relative comfort of the bell.

The increased decompression times associated with mixed-gas diving and the need for added diver comfort resulted in the design of an improved bell system in 1931. Davis designed a three-compartment deck-decompression chamber (DDC) to which the SDC could be mechanically mated to permit transfer-under-pressure of the diver. The DDC provided additional space, a bunk, and food and clothing for the diver's comfort during the lengthy decompression. This procedure also freed the SDC for use by another diving team for continuous diving operations.

The SDC-DDC concept was a major advance in diving safety, but the concept was not applied to American diving technology until the advent of saturation diving. In 1962 E. A. Link employed a cylindrical aluminum SDC in conducting his first open-sea saturation experiment.

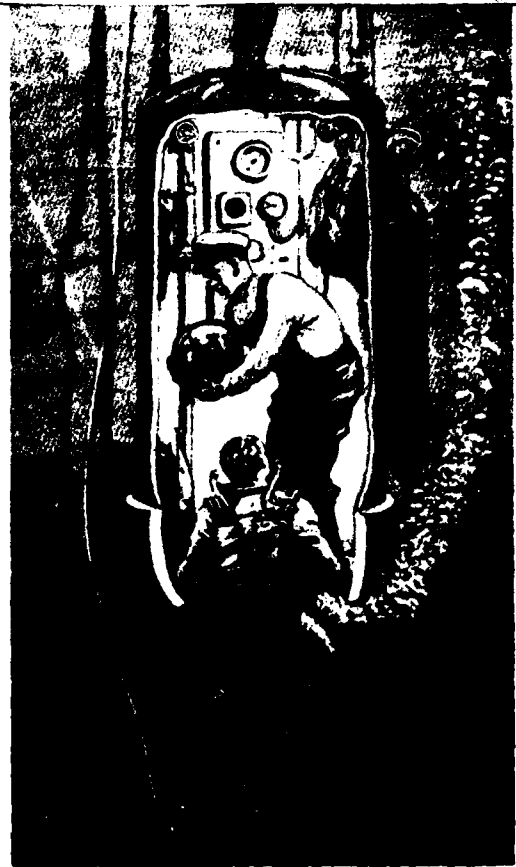

Figure 13-1 Davis Submersible Decompression Chamber

Link used the SDC for both transportation of the diver to the sea floor periments a DDC was used for improved diver comfort. American diving had entered the era of the deep diving system (DDS), and from that time onward advances and application of the concept grew at a phenomenal rate in both military and commercial diving.

U.S. NAVY DEEP DIVING SYSTEMS 13.1

The U.S. Navy currently has only the Deep Diving System MK 2 in operational use.

The U.S. Navy's first DDS, SDS-450, was placed in Fleet Service by Harbor Clearance Unit One in 1967 and was followed by improved versions designated DDS MK 1 in 1969 and DDS MK 2 in 1969. Experience with these systems and advances in diving technology have resulted in a continuous program of development, application, and improvement of Navy deep diving systems.

The basic concept and application of the DDS has changed very little since the time of Davis, although the equipment itself reflects the significant advances made in materials, instrumentation, and life support equipment during the subsequent period. Deep diving systems are used for both saturation and nonsaturation diving, and may be used in both observation (1 atmosphere internal pressure) and pressurized modes of operation.



Figure 13-2 Link's aluminum SDC

Although most SDC's today are still capable of being used for diver decompression without the use of a DDC, the majority of systems employ a multilock DDC and transfer the diver for greater comfort and safety. Some SDC's (now more properly referred to as "PTC's"—Personnel Transfer Capsules) used only in support of saturation diving have single inward opening hatches which require a pressurized mode of diving and cannot be used in a hydrostatic mode for observation. DDS used for non-saturation diving tend to be more compact and mechanically simpler than those associated with saturation diving. The long residence times associated with saturation diving necessitate systems which provide more space in the DDC, have more extensive life support equipment, and more complex instrumentation and controls.

APPLICATIONS OF DEEP DIVING SYSTEMS 13.2

Each of the three modes of PTC operations—observation, nonsaturation diving and saturation diving—has application in various types of missions. Often the modes are combined, such as initial use of the PTC at one atmosphere to study the work area and minimize bottom time in a subsequent non-saturation dive. The DDS is a versatile tool in diving, and application of this type of equipment is extensive. Typical uses include, but are not limited to, the following—

Observation Mode 13.2.1

1. Observation can be made of the placement or alignment of objects on the seafloor or parts of structures in the water column. This type of operation often involves providing voice instructions to a topside handling crew and has the advantage of permitting non-diving personnel to observe and direct the operation from the PTC.
2. The PTC can be used within the lateral limits of the handling system and the ship's mooring system to conduct bottom searches for lost objects.
3. In one-atmosphere comfort diving personnel can study a repair, salvage, or construction project and determine requirements for specialized tools or equipment necessitated by unexpected conditions without incurring a decompression obligation.
4. Scientific or technical visual observations can be made from the comfort and security of the PTC.

Non-Saturation Diving 13.2.2

1. Deep, short term (bottom times usually less than one hour) dives for limited repair, construction, or recovery projects requiring extensive decompression time can be conducted. This mode of operation limits the diver's in-water exposure to that of the actual excursion time from the bell and provides the safety and comfort of the PTC and DDC for the subsequent lengthy decompression and access for medical treatment. Without deep diving systems many dives routinely conducted today would be beyond the limits of human endurance if they were to be attempted with in-water decompression.
2. Short term dives conducted under particularly adverse environmental conditions can be conducted. The short length of the diver's umbilical results in minimum drag in high current situations for dives which are within surface-supplied diving depth but would otherwise be technically impossible.

Saturation Diving 13.2.3

1. Underwater projects which demand extensive bottom worktime (large construction, submarine rescue and salvage) are best conducted with a DDS used in the saturation mode. Multiple diving crews

can be cycled between the easily provisioned and controlled DDC and the worksite to permit continuous diving operations. Operations may be readily discontinued and later resumed if adverse weather threatens the moorings of the surface platform. All equipment necessary to conduct saturation operations is carried by the support ship and may be readied and deployed in minimum time.

2. Bottom habitats used for saturation diving (except those in depths shallower than 30 feet and those capable of maintaining bottom pressure when raised to the surface) require DDS equipment for transport and final decompression of the aquanauts.

3. Deep underwater projects which require moderate bottom work time or diver activities involving work at various depths are conducted in the saturation mode with excursion dives. The PTC and DDC are pressurized to a depth selected within the Ascent and Descent limits of the Unlimited Duration Excursion table graph (Figure 17-2). This procedure minimizes final decompression time.

Other Uses 13.2.4

1. The DDC portion of the DDS may be used in place of a recompression chamber for support of routine diving operations.

MAJOR COMPONENTS OF A DDS 13.3

The configuration and specific equipment which compose a deep diving system varies greatly with the primary type of mission for which it was designed. All modern systems, however, have similar major components, as shown in Figure No. 13-3, which perform analogous functions regardless of their actual complexity.

Personnel Transfer Capsule 13.3.1 Personnel transfer capsules (PTC's) are either spherical or cylindrical submersible pressure vessels equipped with a hatch opening in the bottom for the entrance and exit of the divers. Capacity generally varies from two to a maximum of four divers. Early PTC's occasionally consisted of two separate compartments to

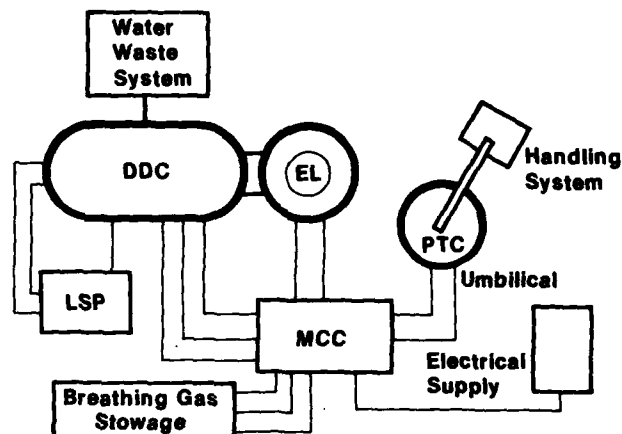

Figure 13-3 DDS major component arrangement

permit their use for diver decompression without a DDC or to allow a non-pressurized observer or tender to accompany the diver. In modern practice PTC's are single compartment capsules to reduce complexity and minimize weight for easier handling. They retain the control capability, however, to decompress the capsule occupants in the emergency circumstance of being unable to employ the DDC.

PTC's are designed to be inherently buoyant with all personnel and equipment aboard. When the intrinsic design of the pressure vessel will not permit positively buoyant operation, buoyancy modules attached to the PTC are used to achieve proper buoyancy characteristics. This safety feature permits buoyant ascent under emergency conditions and necessitates some form of ballast or control mechanism to permit normal deployment to be heaved. The simplest systems employ jettisonable ballast which results in uncontrolled ascent in an emergency. Other systems use either a passive winch on the PTC (connected with a weight) which is used for controlled emergency ascent or, in the most advanced equipment, a submersible electric winch on the PTC which is used in normal operations for positive downhaul and ascent against a weight in addition to emergency ascent.

All PTC's carry emergency supplies of mixed gas and oxygen in pressure vessels mounted on the outside of the pressure shell. The emergency gas

supply provides metabolic oxygen for the capsule occupants and mixed gas for divers or additional bell pressurization in the event of loss of surface-supplied gas or other casualty. On some systems pure helium is carried for bell pressurization, and occasionally an internal emergency supply of oxygen is installed. PTC's generally do not carry sufficient gas aboard to pressurize the interior to full depth rating and supply diving needs because of the associated weight and volume of the required cylinders. Some PTC's used for saturation diving, however, use the onboard gas supply to meet the requirements of the divers' breathing apparatus. This practice eliminates the need for a gas hose from the surface; the PTC is pressurized on deck to operating depth prior to descent.

Umbilicals and underwater breathing apparatus (UBA) for two or more divers are usually stored inside the PTC (either on the deck or on racks). The umbilicals consist of a gas supply hose and a communications cable, which also serves as a lifeline, or a separate lifeline. These elements of the umbilical are often supplemented by the addition of a hot water supply hose for suit and respiratory gas heating for cold water exposures. Although interior stowage of umbilicals and UBA's is space consuming, this disadvantage is offset by the convenience of more rapid donning, doffing, and stowage of equipment and easier tending of the diver(s) by PTC standby personnel.

In addition to the bottom hatch for diver egress and ingress, some PTC's also incorporate an additional hatch on the side for horizontal mating to a DDC. Hatchways are equipped with mating locking flanges for pressure-tight connection to companion units on the DDC for personnel transfer. All PTC's have an inward opening, pressure-sealing hatch over the lower hatchway to retain internal gas pressure during recovery from the bottom and, in saturation diving, during deployment from the surface. The interior hatch usually covers a short cylindrical entrance trunk. The trunk acts as a small floodable volume when divers leave the PTC underwater and, consequently, minimizes flooding of the capsule interior. An external opening, pressure-sealing hatch is employed

over hatchways when capsules are used as hydrostats.

The minimum life support equipment for a PTC includes CO₂ scrubbers consisting of a blower and associated canister of CO₂ absorbent and a gas supply to provide metabolic oxygen. This basic requirement is often supplemented with an analyzer for measurement of the partial pressure of oxygen in the capsule atmosphere. Other systems employ CO₂ analyzers and heating of the PTC interior by electrical resistance heaters or hot water heat exchangers.

Controls and instruments aboard PTC's vary greatly in complexity. Basic internal valving and piping control PTC pressurization and depressurization, emergency breathing gases, and gas flow to the diver(s). Normal design practice requires stop valves at the internal hull surface, and penetrators are normally located only in the lower half of the pressure shell as further precaution against accidental flooding in the event of piping/valving failure. Depth indicators are provided for internal and external pressure measurement. Minimum communications consist of a two-way hardwire voice system. The minimum system is often supplemented with a sonar-type underwater communication set (UQC) and closed-circuit television. Electrical systems vary from the simplest battery pack to power the scrubber and internal lighting to the comprehensive multiple-voltage distribution system used on the MK 2 for heating, internal and external lighting, instrumentation and communications.

Certain other characteristics are commonly found in PTC designs. The PTC pressure shell usually incorporates a number of viewports for use by capsule occupants and surface-support crew. One or more bumper rings around the shell protect the pressure vessel and outside-mounted equipment from impact damage during handling. Many PTC designs incorporate a built-in stand for sitting on the seafloor and simplified servicing on deck whereas others, in order to simplify mating procedures, utilize a separate deck cradle.

Deck Decompression Chamber 13.3.2 The deck decompression chamber (DDC) is a multi-

compartment, horizontal pressure vessel mounted on the surface support platform. DDC's generally include a minimum of two locks (compartments), and may incorporate three or more in systems designed to accommodate operations involving several diving crews. Modular construction (single locks or units bolted together to form the deck complex) is sometimes employed to simplify transportation and add arrangement flexibility.

The two-compartment DDC provides an entrance lock (EL) which permits personnel transfer and mating facilities for the PTC and a larger lock used as a living/decompression area by chamber occupants. In some systems the term "DDC" only refers to the larger living compartment. A few systems, e.g., MK 2, have the PTC transfer hatch in the inner or living lock (IL) of the DDC because of special spacial considerations on the support ship.

The entrance lock has one or more hatchways to the exterior of the vessel which are equipped with inward opening, pressure-sealing hatches. Occasionally pressure-resisting external hatches are used because of internal space limitations. The hatchway(s) permits lock-in, lock-out of attending personnel and divers and usually has the mating flange and locking device for securing the PTC. A hatchway is also provided through the bulkhead to the living compartment for personnel entrance and egress. For regular two-compartment DDC's, this hatchway is closed by a single inward-swinging, pressure-sealing door in the living compartment since in no operational sequence is it desirable to pressurize the EL above living compartment pressure. For modular systems in which the entrance lock may service two or more compartments at different pressures, additional pressure-sealing doors are fitted on the EL-side of the bulkhead hatchways.

Entrance locks usually contain a minimum of equipment since normal personnel residence time in this area is short. They are designed to be as small as practical to conserve gas used in pressure cycling. The EL tends to be a wet area because this location is used for the removal and storage of exposure suits and other equipment by divers returning from operations. Since this area can be segregated from

the primary living area, it is often used as the location for the sanitary facilities in addition to gear storage.

Basic sanitary needs may be served by a simple bucket or portable head but many DDS incorporate a hot water shower (particularly useful for rewarming divers), a wash basin and water-flush head. Such sanitary water supplies and drainage systems must maintain a controlled differential water supply pressure over chamber conditions. In addition they must be equipped with safety interlocks to preclude accidental personnel exposure to the pressure differential of atmospheric conditions.

The main lock of the DDC must be large enough to prevent occupants from being forced to adopt a cramped position during decompression. Systems used for saturation diving must be much larger, and at least some portion of the facility should have full standing head height. A small lock is built into the side or end head of the compartment for the passage of food, medical supplies or other articles between the diving crew in the chamber and outside personnel. Viewports built into the sides and end of the pressure shell permit the visual monitoring of occupants and are often used for illumination of the lock interior by externally-mounted lights. Bunks are usually installed for the comfort of the diving crew.

The basic control and piping system of a DDC is similar to that of a recompression chamber and includes internal valving and a caisson gage. Control valves on the exterior of the shell are normally used to control all gas flow into and out of the chamber complex. In many DDS deck complexes, however, control of the DDC environment is performed from a separate central control panel located at a distance from the chambers and connected via cables and hoses (or hard piping). In this type of design, valving on the chamber is used as a backup mode of operation. Separation of the control function from the chambers often permits greater flexibility in location of the DDC aboard ship, reduction in unit volume for shipping, and environmental protection for chamber operators.

Fire in the closed environment of the DDC presents a significant hazard. As a consequence, DDC's should have some type of fire fighting provisions. Equipment

ranges from simple sand and water buckets to fire hoses with external, pressurized water supplies to, in the most advanced systems, water deluge nozzles actuated manually or automatically by flame sensors. As in recompression chambers which have a similar hyperbaric flammability hazard, all ignition sources are eliminated and the use of combustible materials is minimized during critical fire zone times. Mask systems are installed in all locks for emergency breathing in contaminated atmospheres as well as normal administration of oxygen during decompression. PTC's do not usually have built in firefighting equipment because they are usually operated in a depth range in which the oxygen concentration in the gaseous environment will not support combustion (See Chapter Ten), and the difficulty of installing such a system within the severe space and weight limitations of a PTC.

Life support for a DDC used in non-saturation diving for shallow operations may only consist of the capability to adequately ventilate the locks with air. In most systems, however, a CO₂ scrubbing capability and O₂ monitor are provided. The precise control of environmental conditions demanded in saturation diving necessitates the addition of temperature, humidity and impurities controls and monitoring of the carbon dioxide concentration. The equipment necessary to maintain desired conditions is usually located outside the pressure vessels with associated sensors and ducting inside.

Minimum communications in the DDC consist of an open-circuit, two-way audio communications set to permit chamber operators to monitor the diving crew. Helium unscramblers are routinely installed to improve speech clarity. A sound-powered phone system is often installed as a backup for voice communications, and closed-circuit television (CCTV) cameras are commonly employed for visual monitoring of chamber occupants.

Life Support Systems 13.3.3 Major components of the life support system (LSS) are normally located external to the DDC. They may be wholly or partly mounted on the outside of the pressure shell to minimize piping, or be grouped in a separate module.

Heating and cooling units employing circulating water are used in saturation systems and also in

some non-saturation systems when DDC's are subjected to extreme environmental temperatures. The circulating water feeds one or more heat exchangers located either inside the DDC locks or within external combination scrubbers which circulate the lock atmosphere. When humidity control is employed to increase comfort and minimize skin problems, a cold water exchanger is used for condensing water from the chamber atmosphere, and a hot water exchanger is used for reheating the gas.

Carbon dioxide scrubbers located outside the DDC are usually housed within groups of pressure vessels which function at chamber pressure. This type of design minimizes the size and power requirements of the explosion-proof recirculating blower installed in the assembly. A minimum of two pressure vessels arranged and piped in parallel are used to permit depressurization and changeover of the CO₂ absorbent canister via a quick-opening hatch while maintaining one scrubber on-line.

The life water waste system often contains the supply/receiver equipment for a flush-water sanitary system. This type of system includes water pressurization pumps (or a pressurization tank for batch systems), water heaters, sewage holding tanks and associated piping and controls. Some systems also include a macerator and sewage pump to transfer wastes to the ship's sewage system.

Controls for operation of the life support systems are normally an integral part of the equipment and are locally operated. Various chamber monitoring analyzers and malfunction indicators at the main control console (MCC) provide information on system performance and the possible need for corrective operator action.

Control Console 13.3.4 A main control console (MCC), located near the DDC in a weather-proof van or below deck, provides operating controls and monitoring devices to ensure safe operation of the DDC, EL, and PTC. Electrical power distribution (sometimes as a separate console), metabolic gas, pressurization, vent and decompression, lighting, communications, and system monitoring are usually all controlled from the console. When the control console is housed in a van, the module usually contains a window for obser-

vation of the exterior of the DDC. The van provides lighting, heating and air-conditioning for the operators and equipment.

The gas section of the console provides control of the various gas supplies and operating pressures in the DDC and EL. The console operator controls pure oxygen, one or more helium-oxygen mixtures, helium and compressed air delivery to the chambers. Additional valving is provided for decompression control which is normally performed manually because of its singular importance. Occasionally, however, DDS control consoles are fitted with automatic decompression controllers. Separate valving is provided for control of surface-supplied gas to the PTC and/or the charging of the onboard PTC gas supply flasks. Pressure readouts on the console monitor the internal condition in the DDC locks and PTC as well as PTC and diver depth.

An oxygen partial pressure analyzer readout for the DDC (and PTC in advanced systems) is usually located on the MCC, also CO₂ partial pressure information is provided for saturation systems.

All communications systems in the DDC and PTC are controlled from this location. The operator may direct voice communications between divers, PTC, DDC and MCC as required. The intercom system is often supplemented with a helium voice unscrambler, a tape recorder for monitoring conversations, a radio tuner for entertainment of off-duty DDC occupants, and CCTV monitors connected with cameras installed on the DDC, EL, and PTC.

For all but the simplest deep diving systems, electrical power requirements are substantial. Power control components are usually grouped in the main control console or are separately housed in the immediate vicinity to simplify coordinated overall control of the DDS. Primary power is supplied by the ship; a backup supply for critical systems is always provided. Backup may take the form of emergency batteries and an inverter, a separate auxiliary generator, or the ship's auxiliary system. The power control console (PCC) or panel contains the required circuit breakers, transformers, battery chargers, and power transfer gear required to protect and monitor the electrical supply to all systems.

DEEP DIVING SYSTEMS

PTC Umbilical 13.3.5 The PTC is connected with the surface platform via an umbilical cable. The configuration of the umbilical is dependent upon the design of the PTC, and whether it is primarily intended for saturation or non-saturation diving.

For some saturation systems, sufficient gas is carried aboard the PTC to supply the divers' breathing apparatus. The capsule is pressurized from the DDC prior to descent. Since additional gas from the surface is not required, this type of system employs a single composite cable which performs three primary functions (strength-power-communications cable-SPCC). The SPCC acts as a strength member to raise and lower the PTC (even if flooded) and conducts electric power, wired communications, and coaxial transmission (CCTV signals) between the MCC and the PTC. The SPCC terminates in a mechanical breakout which is secured to a lifting eye on top of the PTC.

Saturation systems which employ diver breathing apparatus having a large gas demand, e.g., MK 1 mask, usually require supplemental gas supplied from the surface. Such systems usually have an umbilical consisting of two hoses (one for gas supply, one for a pneumofathometer and supply backup), a communications cable, a power cable, and a lifting cable. In practice hoses, communications and power cables are normally married together to form a single umbilical which may be fastened to the lift wire during PTC deployment. The umbilical is unfastened, coiled and stowed during PTC ascent. A similar arrangement is used for a PTC employed in nonsaturation diving.

When hot water is used for diver heating, an additional hose must be added to the umbilical. When an SPCC is used, the hot water hose may be temporarily fastened to the cable as previously described; when a composite hose/cable bundle is used, it is included as an integral part of the bundle.

The use of a single umbilical cable rather than separate hoses and cables minimizes current effects and simplifies handling. The SPCC-approach simplifies deck operations but necessitates large deck equipment to maintain the minimum bending radius of the cable and presents operational repair problems be-

cause of its special construction. The composite system, while minimizing repair problems and lifting machinery size, necessitates additional deck personnel for fastening/removal and stowage operations.

PTC Handling Systems 13.3.6 *Of all elements of deep diving systems, none are more varied than PTC handling systems. Launch and retrieval of the PTC through the air-sea interface and mating with the DDC present significant hazards to the divers aboard during heavy weather and is a major factor in the configuration and operation of the handling system. Further variability is introduced as a consequence of the differences in the configuration of the various surface platforms used and the placement of DDC's.*

All handling systems, however, have certain common characteristics. The system should—

- A.** Be designed and well maintained to withstand the shock loads imposed by heavy weather.
- B.** Have the ability to pass the PTC through the air-sea interface at sufficient speed to avoid excessive wave action.
- C.** Keep the PTC well clear of the superstructure of the surface-support platform to avoid impact damage.
- D.** Have a winch of sufficient power to permit fast retrieval of the PTC to match decompression ascent rates for non-saturation diving. The winch must also be of sufficient size to store all cable required while maintaining a safe minimum cable bending radius. Controls and brakes which permit precision control for PTC mating and approach to the seafloor are essential.
- E.** Include a translation system to move the suspended PTC to and from the launch/retrieval position astern, athwartship or amidship to the DDC.
- F.** Have a method to restrain PTC movement during mating to the DDC.

The simplest handling systems are those which are an integral part of the DDC complex. Such packaged systems employ a hydraulically inclined A-frame equipped with a sheave over which the PTC lift wire passes to a winch on the DDC frame. The location of the DDC package aboard ship is critical since it must



Figure 13-4 PTC handling system for MK 2 MOD 0 DDS.

be in close proximity to the gunnel of the surface platform to provide sufficient outboard deployment of the PTC.

Other handling systems, particularly for smaller PTC's, employ separate A-frames, cranes, booms, or davits to provide sufficient outreach over the side or through wells for safe PTC deployment. Such systems, commonly used on ships of opportunity, usually employ manually or tugger-winch restrained tag lines temporarily attached to the PTC during deck movement.

Larger PTC's, such as those used in the USN MK 2 system, require special handling provisions. The MK 2 PTC is deployed through the center well of salvage and rescue ships (IX-501, ASR-21 class) with a gantry crane. A special capture basket, which surrounds the upper portion of the PTC, is used underwater in the launch and retrieval process to minimize surface wave effects.

The MK 2 systems employ a large deck winch to provide lifting force to the SPCC and through slip ring assemblies transmit electrical power and communi-

cations to the PTC. The other lifting equipment aboard ship is primarily employed for translation of lifting forces and movement of the PTC to the DDC for mating.

Underwater Breathing Apparatus 13.3.7 Divers working from a PTC are always tethered as a safety precaution. Even when completely self-contained breathing apparatus is employed, a safety line between diver and PTC is essential to preclude the significant hazard posed by the diver being unable to find and return to the safety of the capsule. Voice communications between the diver, PTC tending personnel, topside, and other divers is also a requisite for safe operations.

A wide variety of breathing apparatus can be used from PTC's. Demand masks, lightweight recirculating helmets, semiclosed and closed-circuit apparatus, and pumping units which circulate the PTC atmosphere to the diver are all successfully used. The choice of apparatus is governed by operational considerations including required bottom time, gas logistics, personnel training, checkout and servicing time, and maintenance requirements.

Demand masks, such as the USN MK 1, and lightweight demand helmets are commonly used in operating situations in which gas logistics do not present a problem or in non-saturation diving when bottom time is short. Occasionally the MK 1 mask is used as an emergency backup rig for closed or semiclosed apparatus. The simplicity of construction and operation, and compactness of this type of apparatus offer distinct operational advantages which in certain types of operations offset the greater gas consumption.

Operations involving extensive bottom time, e.g., saturation diving, and/or great depths normally require the use of a recirculating breathing apparatus to minimize gas consumption. The MK 11 semiclosed-circuit rig is used by the USN for this purpose. These apparatus, always used in a tethered mode for diver safety, are equipped with special hot water jackets for gas and canister heating. Lightweight helmets equipped with recirculating systems are also used in some deep diving systems.

DEEP DIVING SYSTEMS

One of the newest breathing systems, the MK 14, employs a compressor-depressor system to pump the PTC atmosphere to the diver and back to the PTC. Inspiratory and expiratory gas flow through a two-hose umbilical is controlled by two regulators on the diver's mask. This type of system employs the PTC life support system to purify and control the diver's breathing medium, and consequently eliminates the bulk and complexity of a diver-worn recirculating apparatus.

DEEP DIVING SYSTEM OPERATIONS

13.4 Detailed operating instructions for installation, deployment, retrieval, mating and decompression vary significantly from one diving system to another. Instructions for use of advanced DDS, such as the USN MK 2, are extensive and beyond the scope of this manual. Such detailed information is essential for the safe operational use of the subject DDS, and the reader is referred to the appropriate operating manuals.

General Criteria 13.4.1 This section of the Diving Manual details the operating principles and sequence common to most deep diving systems used in the three major modes—observation, non-saturation, and saturation diving. Prior to initiating actual DDS operations, the following criteria must be met for the specific system in use—

- A.** The DDS must be installed, operated, and maintained in complete accordance with the system's operating instructions.
- B.** All support and diving personnel must be trained and qualified for the DDS being used.
- C.** All stations must be manned in accordance with written instructions.
- D.** All diving personnel must be qualified with the specific UBA to be used.
- E.** The support ship must be securely moored, and all ship's systems relating to support of the DDS must be fully operational.
- F.** All team personnel must be thoroughly familiar with emergency procedures for the DDS. All systems, subsystems, components and backup facilities related to the safety of the DDS and occupants must be functioning properly.

Observation Diving 13.4.2 The following operating procedure is used in conducting a one atmosphere (non-pressurized observation) dive—

1. Pressurize the DDC to the maximum operating depth to be encountered by the PTC. This is done as an emergency precaution to ensure that the DDC is operational in the event that the PTC must be pressurized in an emergency and occupants require decompression.
2. PTC occupants board the capsule on deck. They perform a predive checkout and activate gas, electrical, communications, life support and ballast systems aboard the PTC. All pressurization capabilities must be functional.
3. The external trunk hatch is closed and dogged by PTC personnel. The DDS MK 2 requires installation of the removable external hatch prior to use of the PTC in the hydrostatic mode.
4. Carbon dioxide removal and oxygen monitoring/control systems are checked for proper operation.
5. Slack is taken up on the lift cable and PTC hold-downs are removed. Steadying (tag) lines are attached to the PTC (when required) and tensioned.
6. PTC occupants brace themselves for transit and advise the Main Deck Supervisor of their preparedness.
7. The PTC is lifted by the handling system, moved across the deck, and positioned over the side or centerwell.
8. If the PTC is to be used in a free descent, negatively buoyant mode with a clump, it is now ready for deployment. If it is to be used in a positively buoyant mode, the downhaul winch on the PTC is allowed to unspool cable until the clump reaches bottom.
9. The PTC is lowered through the air/water interface as rapidly as possible to obtain a hatch seal and transit this potentially hazardous zone.

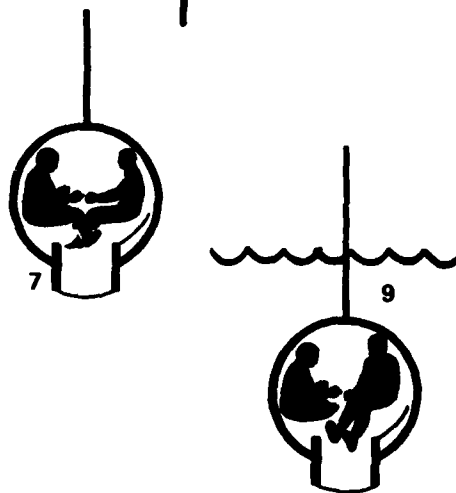
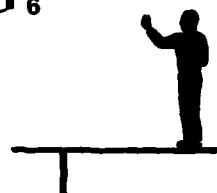
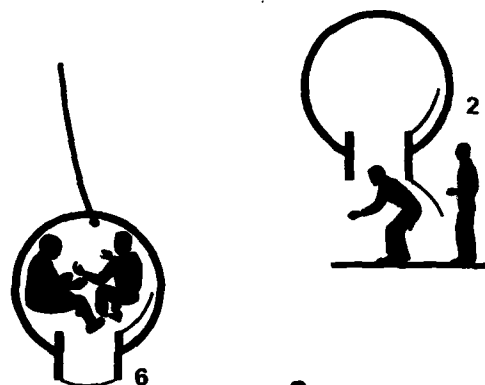
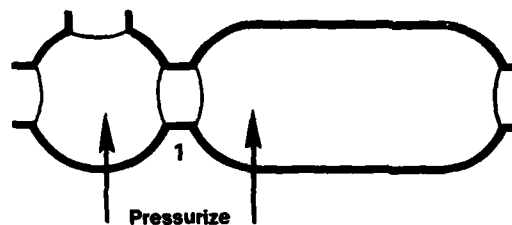

10. If steadying lines have been used, they are removed by ship's divers. If a separate cable and winch are used to raise and lower the PTC after it is underwater, the main lift wire is also removed at this time.
11. The PTC is lowered to the observation site under the voice direction of PTC personnel. If the PTC is designed to be surface-supplied with gas, the umbilical is continuously secured to the lift wire by chain binders attached by deck personnel during PTC descent. This procedure ensures that a PTC pressurization capability is always available for emergency use. When a PTC downhaul winch is used, PTC personnel control the winch but close coordination is required with the deck winch operator.
12. While in the observation mode, PTC occupants must monitor the oxygen partial pressure and scrubber operation and add O₂ as required to maintain a life sustaining environment inside the PTC.
13. Upon completion of the task, PTC personnel advise topside that they are ready for ascent.
14. The PTC is lifted to just below the air/water interface and held there while divers attach steadying lines and the main lift wire (if required).

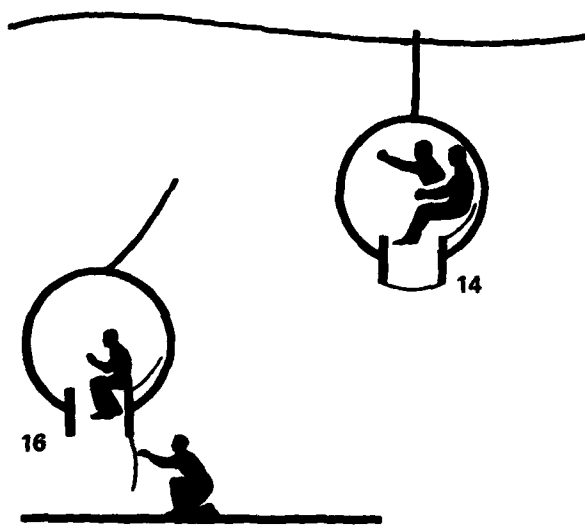

15. The PTC is rapidly lifted aboard the ship and secured in its stowage position.
16. The lift line is slackened, the lower hatch is opened, and PTC personnel exit from the capsule.
17. A postdive checkout of the DDS is conducted and the system is secured or readied for further operations.

Non-Saturation Diving 13.4.3 Non-saturation diving is conducted with a DDS to meet operational requirements and in the training of saturation divers. This mode of diving is usually conducted using the observation technique initially, followed by pressurization of the PTC on the bottom to minimize bottom time. Preparatory procedures are similar to those in Section 13.4.2 with the additional requirement that the UBA and other diver equipment must be thoroughly checked prior to descent. Upon reaching the work site the following procedures are used—

1. The working diver(s) dons his UBA and prepares his umbilical for deployment.
2. The external hatch is undogged and the PTC is pressurized by the divers using either surface-supplied or PTC-supplied gas (depending upon the PTC design and depth) until the internal gas pressure equals the external water pressure. Bottom time begins as soon as pressurization commences.



3. The lower hatch is opened when internal and external pressures are balanced. The diver checks his breathing apparatus and turns on the hot water supply to his suit (if used).
4. He enters the water, takes his bearings on the job site, and swims to the site trailing his umbilical behind. The umbilical is tended by the diver inside the PTC and continuous voice communications are maintained.
5. When completed with the task, the diver returns to the PTC and removes his diving gear. If additional underwater work is required, the other diver(s) dons his gear, swims out from the PTC, completes his work and returns.
6. When ready to come up, the divers close and dog the internal hatch.
7. The divers signal the Main Deck Supervisor of their preparedness to ascend. The PTC is lifted to just below the air/water interface at the best safe speed possible. During initial ascent from the bottom, the divers must ensure that the internal hatch is properly sealed and that no gas from the PTC is being unintentionally lost. This is done by monitoring the PTC caisson gage. Loss of internal PTC pressure requires a halt in ascent until the situation can be corrected.
8. Decompression time may begin as soon as the PTC leaves the bottom. During PTC ascent, the divers reduce the internal pressure of the capsule by exhausting gas to the sea to match the decompression schedule being used (Surface-supplied mixed gas or air tables).
9. The PTC is lifted aboard ship after the attachment of steadying lines and lift wire (if required). The DDC pressure is adjusted to match the internal pressure of the PTC.
10. The deck crew removes the external PTC hatch and secures it away from the entrance trunk. The PTC is mated and locked to the DDC. The divers are advised to undog the inside PTC hatch.

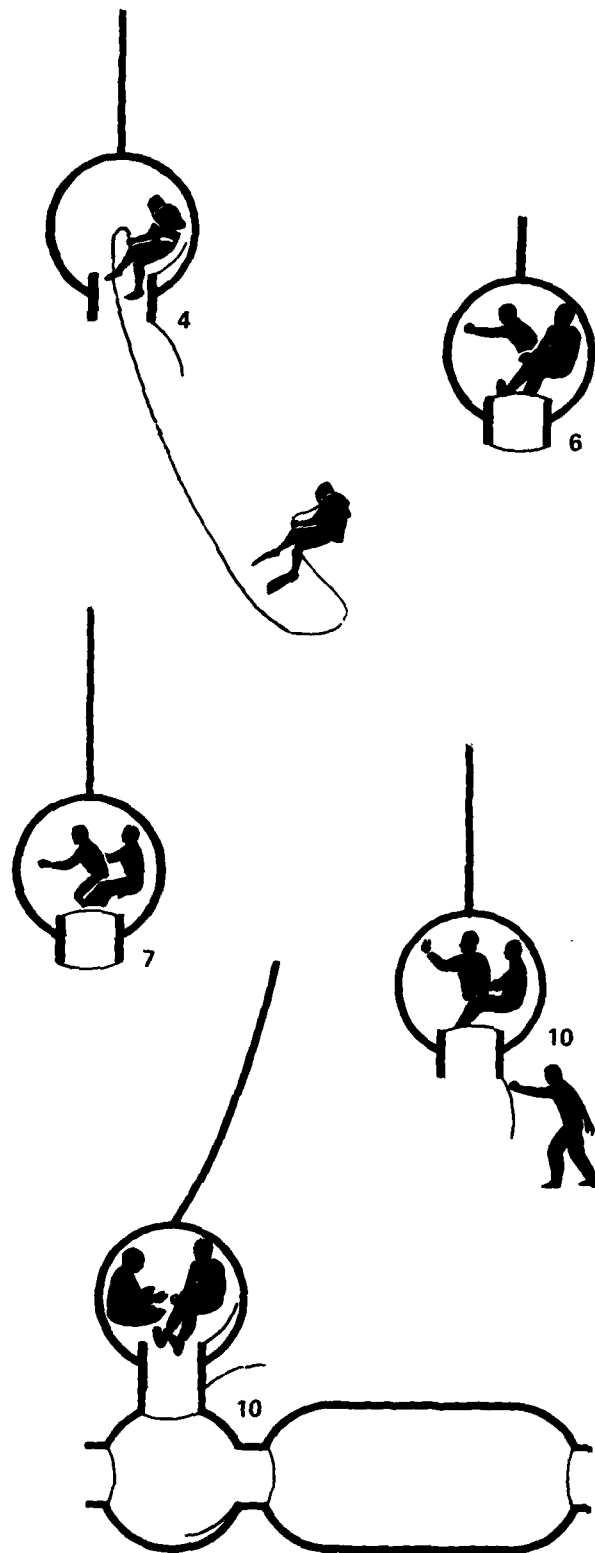

11. The PTC trunk space and matching transfer trunk on the DDC are pressurized to equal the PTC and DDC pressure. The divers open the internal PTC hatch and the DDC hatch and transfer to the DDC. The DDC hatch is closed by the divers.
12. The divers transfer to the main lock of the DDC and close the entrance lock hatch behind them. The PTC is depressurized by the deck crew. The entrance lock of the DDC is maintained at main lock pressure as an emergency escape area for chamber occupants in the event of fire or atmospheric contamination.
13. Decompression of the divers in the DDC is continued following the selected schedule.
14. The PTC is removed from the entrance lock, moved to its stowage position, and serviced for future use.
15. Transfer of food and other supplies to the divers in the main lock is accomplished using the DDC medical lock. Transfer of personnel into and out of the main lock is performed using the entrance lock.

Saturation Diving 13.4.4 In saturation operations PTC deployment, swim out, retrieval and mating procedures are similar to those previously described except that the divers are maintained at constant bottom pressure until final decompression. Modification in procedures for saturation diving include—

1. For initial pressurization the PTC (with internal hatch open) is locked onto the DDC, and divers enter the DDC and secure the hatches.
2. The DDC and divers are slowly pressurized to bottom depth following procedures given in Chapter 17.
3. The PTC is pressurized to bottom depth. The divers transfer to the PTC from the DDC and close and dog the DDC hatch behind them. They then close the PTC internal hatch.

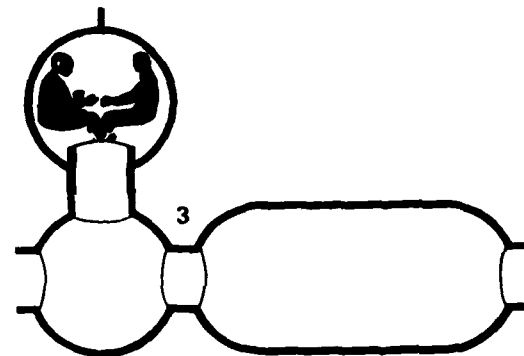
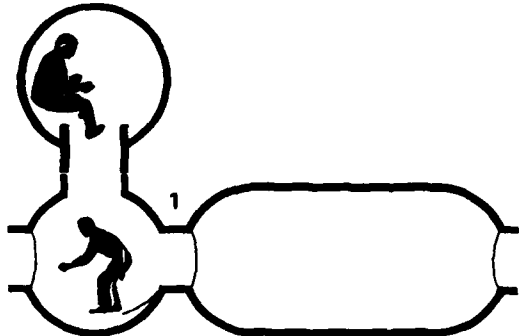
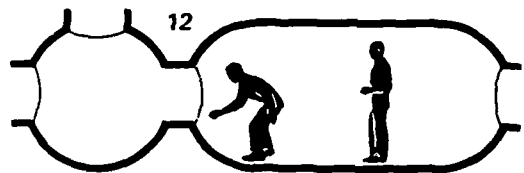
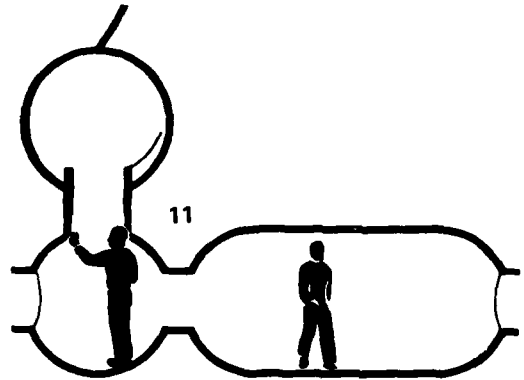

4. The PTC/DDC trunk space is vented to atmospheric conditions. The PTC is unlocked from the DDC and deployed as previously described.
5. The PTC is lowered to working depth. When seawater and internal PTC pressures are equal (observed by PTC gages), the internal hatch is opened.
6. Gas is added to the PTC to displace seawater in the trunk. Diving equipment is donned and checked and the diver(s) swims out of the PTC to accomplish the underwater task.
7. Saturation divers make excursions shallower or deeper than the PTC within the limits of the excursion tables and procedures.
8. Upon return to the PTC and stowage of gear, the divers secure the inside hatch and advise the surface to initiate ascent. Particular care must be exercised by the divers to ensure a complete hatch seal since even minor pressure reductions in the PTC atmosphere impose an unprogrammed decompression.
9. The PTC is raised, mated, and the divers are transferred to the DDC. If two teams of divers are being used with one DDC complex, the second team transfers to the PTC after the capsule and diving apparatus is serviced.
10. The divers rotate between periods of living in the DDC and work on the bottom from the PTC until time for decompression.
11. The divers are decompressed in the DDC following procedures in Chapter 17.

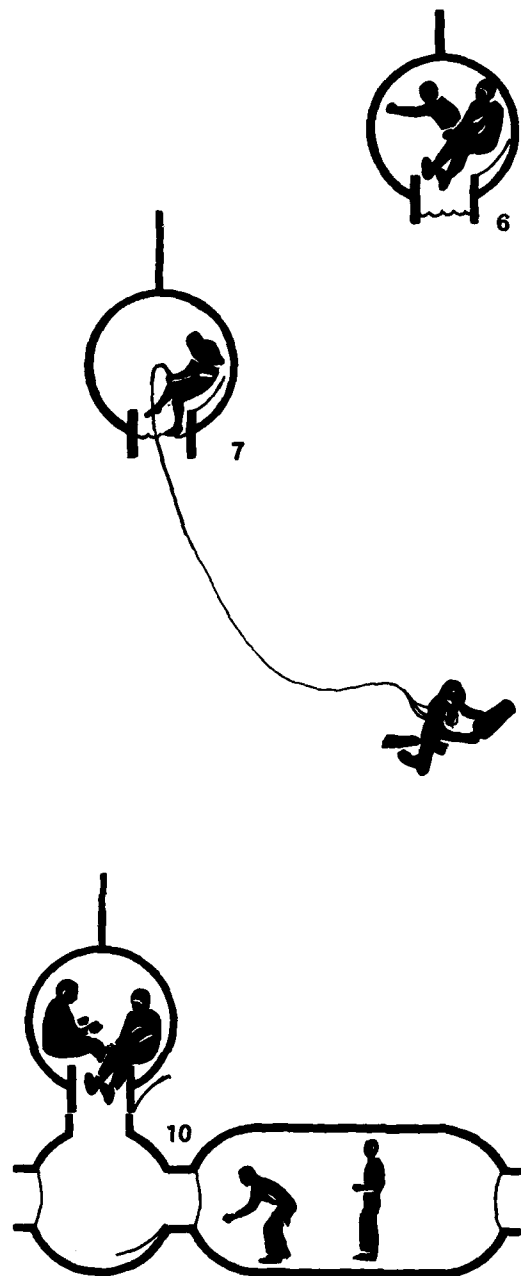

DEEP DIVING SYSTEM EMERGENCY OPERATIONS 13.5

As has been discussed, the use of a DDS significantly adds to diver safety for deep water operations by minimizing in-water exposure time and providing a local refuge for the diver at the work site. Certain dangers exist in DDS operations, however, which may or may not have a counterpart in conventional diving.

General Criteria 13.5.1 In the design of a well-engineered DDS, potential operating hazards are evaluated and features are built into the equipment or redundant subsystems are employed to reduce potential dangers. In certain instances hazards are an integral aspect of the operation and must be overcome by carefully prepared and executed operating procedures. Typical of design safety features are the inherent buoyancy of the PTC, redundant life support components, and mask breathing systems. Procedural approaches to safety are noted in the prohibition of ignition sources and flammable substances inside the DDC.

Few DDS emergency systems operate automatically; the actuation of the majority of such systems and execution of proper emergency procedures require timely, correct action by the DDS crew. Such action demands a well-trained operating crew who have practiced emergency drills and are thoroughly familiar with all aspects of operation of the specific system being used.

It is impossible to list all the types of emergency circumstances which may occur in DDS operation. As an example, the maintenance of saturation pressure is of critical importance and may be affected by the malfunction, damage or improper operation of numerous components which results in an emergency situation. The following emergencies and associated corrective procedures are considered to be those which may be most generally encountered. Detailed operator action for a specific DDS will be found in the respective operating manual for the system.

DDC Emergencies 13.5.2 Of the several types of emergency situations which may develop in the DDC, the most serious are the uncontrolled loss of

pressure and fire. Failure of the life support, power, and communications also pose hazards but are generally of lesser consequence.

FIRE IN THE DDC 13.5.2.1 Two types of fire may occur under hyperbaric conditions—the flash fire and the slow burning fire. Of the two, the flash fire is the most serious and must be combatted within seconds of initiation. A slow burning fire, e.g., wire insulation, which is not promptly extinguished may initiate a flash fire depending upon available fuel, oxygen concentration and type of inert gas in the chamber atmosphere. In addition to the dangers posed to chamber occupants from heat and scorching, products of combustion may rapidly contaminate the atmosphere. The emergency procedure is as follows—

1. The MCC operator secures all electrical power to the DDC and turns on DDC emergency lights.
2. Standby diver wakes all divers.
3. Divers vacate the lock, if possible, and secure the bulkhead hatch.
4. Lock occupants go on mask breathing (BIB system).
5. Transfer personnel to PTC, if possible, demate and move PTC to safe location.
6. Secure all gas supplies, ventilation and LSS to the lock containing the fire.
7. Depressurize the DDC and fight the fire with external personnel.
8. When the DDC is serviceable, return to depth, reactivate LSS and transfer personnel from the PTC.

If the location of the fire prevents the escape of personnel to another lock or the PTC, they must immediately don breathing masks and fight the fire using the lock's fire fighting equipment.

PRESSURE LOSS OR INCREASE IN THE DDC 13.5.2.2 Pressure in the DDC, particularly in saturation diving, must be controlled at all times within narrow limits. An unplanned increase or decrease in pressure is an indication of some failure or malfunction.

tion in the system. Changes in pressure must be detected promptly by MCC operators and corrective action taken. In saturation diving the rate of depth change and the amount of depth change must be within the limits of excursion tables and procedures. In the event of pressure loss—

1. Alert divers.
2. Maintain lock pressure by adding gas. If ppO_2 level drops, divers use BIBS.
3. Divers vacate lock, secure bulkhead hatch and transfer to the PTC. They close the trunk and PTC hatches.
4. The source of leakage is determined by sequential isolation of locks, LSS, DDC valving and other chamber penetrations. Leak testing is facilitated by use of a helium leak detector or soap solution.
5. The source of leakage is corrected, pressure and ppO_2 level restored, LSS reactivated and personnel transferred back to the DDC.

Pressure increase can result from either a malfunction in the LSS which allows temperature to rise or by the bleeding in of gas. In either case pressure level is maintained by venting excess gas. Corrective action then proceeds while the ppO_2 level is monitored. The LSS units are alternated or gas inflow lines are sequentially secured until the pressure increase ceases.

OTHER DDC EMERGENCIES 13.5.2.3 Failure of the life support system can result in loss of control of temperature, ventilation, humidity, CO_2 and ppO_2 . Redundant life support systems are mandatory for saturation diving systems and desirable for non-saturation diving. Failure of the on-line system requires switching to the alternate while repairs are made. Loss of the recirculating blower in the system is particularly serious because a lack of circulating chamber gas will result in an inability to maintain temperature, humidity and CO_2 levels. Failure of the primary ppO_2 control (or monitor) necessitates switching to an alternate automatic system or manual analyzer backup. In situations involving a DDS with only one LSS or failure of the backup unit, it is necessary to purge the chamber with $He-O_2$ to maintain a physiologically safe $ppCO_2$ level or have the divers use the BIBS until the sys-

tem can be returned to service. Gas purging may also be required if primary power is lost to the LSS and emergency power is unavailable.

PTC Emergencies 13.5.3 Because of the isolation of the PTC while engaged in underwater operations, many emergency situations involving the PTC necessitate prompt corrective action by the divers themselves. This is particularly true at depths which are unreachable by divers from the surface.

Malfunction of PTC systems or supportive handling equipment are invariably serious situations. The loss of pressure integrity or the ability to raise the PTC to the surface can have grave consequences unless effective emergency procedures are implemented.

PTC ENTANGLEMENT 13.5.3.1 The PTC may become entangled at work depth by cables, obstructions at the work site, fouling of the downhaul winch due to cable spooling, and the umbilical fouling in the PTC structure. Four possible methods of correction are available, and regardless of the technique used, continuous communications with topside are required to ensure proper supportive action on the part of the surface crew. A major consideration is the duration of life support available to the PTC divers.

1. The simplest circumstance is one in which the PTC divers alone (or with the assistance of support divers) can exit the PTC and eliminate the obstruction. The PTC is then raised in its normal mode.
2. If the degree of entanglement is not judged to be too severe as to break the lifting cable, a positive lift may be made with the SPCC winch. The PTC hatch is secured and the downhaul winch is braked. The support ship is moved up-current in the moor while paying out cable. This is a safety precaution in the event that the downhaul cable or clump are lost and result in a buoyant PTC ascent. The SPCC winch lifts the PTC in a negative mode.
3. A hopeless degree of entanglement or inadequate onboard life support duration (surface-supplied gas PTC's can be purged to extend limits) necessitate the use of a second PTC to rescue the divers. Great care must be exercised by the surface crew to deploy the second PTC close enough to the stranded capsule

to permit divers to swim over while precluding the possibility of entanglement of the second capsule in the umbilical of the first or the initial obstruction.

4. A buoyant free ascent may be employed in situations when the umbilical or SPCC is hopelessly entangled. This procedure requires the severing of the umbilical and liftwire or SPCC. The support ship must be moved as previously described while paying out lift cable. For PTC's having a lift wire/umbilical system, the PTC divers must cut the connections at the PTC. Communications with the surface are maintained by UQC operating on emergency power. The hatch is secured and divers strap down and don protective headgear. Upon surfacing, the ship's crew secures a lifting line to the PTC and transfers it to the DDC for mating.

PTC PRESSURE LOSS AND FLOODING

13.5.3.2 PTC flooding may result from any loss in gastight integrity (leaking hull penetrations or viewports) or tipping while submerged with the hatch open. Flooding from tipping, usually caused by current effects, is generally not serious since the SPCC can be employed for righting the capsule, divers can use the BIBS, and excess water can be discharged by adding gas to the bell. Loss of gas (and water) integrity, however, constitutes a serious casualty. Actual flooding under this condition is of far less concern than the loss of pressure-holding capability. This type of situation is particularly serious in saturation diving.

Any loss in internal PTC pressure during deck handling or flooding during descent is immediate cause for aborting the dive and transfer of personnel to the DDC while the PTC is being repaired. Addition of gas to the PTC is used to counteract the loss and minimize flooding.

If the PTC is flooding (water level rising) while at depth or during ascent, the following procedure is employed—

1. Recover divers (if at depth) and add gas to stabilize flooding.
2. Investigate the source of leakage and advise topside of the extent of the leak.

DEEP DIVING SYSTEMS

3. Pressure loss can result from—
 - a. Exhaust valves not fully shut.
 - b. Leaking hull penetrators and cable glands.
 - c. Foreign objects between hatch and sealing surface.
 - d. Damaged or defective hatch gasket.
 - e. Sprung or maladjusted hatch.
 - f. Cracked or non-sealing viewport.
4. Topside must determine whether to recover the PTC or transfer divers to another PTC (if available). Consideration must be given to—
 - a. Nature of the leak and rate of pressure loss.
 - b. Capability of maintaining gas pressure and duration using the onboard PTC supply, or surface supply if used, until the PTC can be mated.
 - c. Time required to deploy a second PTC.

5. If the pressure loss occurs on ascent, lowering the PTC may reduce the loss while the situation is corrected. Any leakage of gas from the PTC will probably increase during ascent (lower hydrostatic pressure, greater pressure differential) unless corrective measures are employed.

6. The PTC divers (with assistance from support divers if practical) should attempt to correct the leak. Inspect the hatch seal and fit of the hatch. Check hull penetrations and tighten. If the pressure loss cannot be corrected and would be too rapid to permit a safe ascent, a second PTC must be employed.

OTHER PTC EMERGENCIES 13.5.3.3 Loss of surface-supplied electrical power in the PTC is readily handled by switching to the onboard emergency battery supply. This system is sufficient to power the life support system and analyzers but is insufficient to power an electrical downhaul winch (if used). Submersible winches are designed to automatically brake if primary power is lost and necessitate a negative mode lift by the deck equipment. Internal short circuits can be isolated by sequential actuation of onboard circuit breakers. PTC divers go on BIB system as a safeguard against atmospheric contamination. A short circuit in the SPCC requires that the dive be aborted.

Two-way communications between the MCC and PTC are vital. A partial communications failure involving the helium unscrambler and intercom dictates that the dive be routinely aborted. A total loss of communications demands a prearranged procedure to be followed by topside and PTC personnel as follows—

1. Recover divers and secure hatch.
2. If a downhaul winch is used, it is placed in the BRAKE position. The PTC will be lifted in the negative mode.
3. When communications are initially lost, the Diving Officer will allow time to give the PTC operator time to recover divers.
4. The Diving Officer will set off two light underwater explosive charges to notify divers that a 15-minute standby period has begun and broadcast on the UQC.
5. One minute prior to raising the PTC, the Diving Officer will set off a single explosive charge.
6. After the one-minute warning, PTC recovery will begin.

DEEP DIVING SYSTEM MK 2 13.6

The Deep Diving System Mark 2 consists of a family of structures, operating systems, and associated equipment designed to support saturation diving operations on board the ASR-21 class of Navy submarine rescue ships and other specially configured ships. Major components of the diving system are: (1) two deck decompression chambers with their life support systems; (2) two personnel transfer capsules; (3) two main control consoles; (4) two SPC cable winches and their associated Strength, Power and Communications (SPC) cables; (5) ship support equipment; and (6) one helium recovery system. The components (port set, starboard set) that make up the diving system actually form two operational diving systems (port and starboard) with a common helium recovery system. The diving system is not self-supporting and depends on the support vessel for electrical power, potable water, chilled water, steam, handling, waste disposal, and compressed

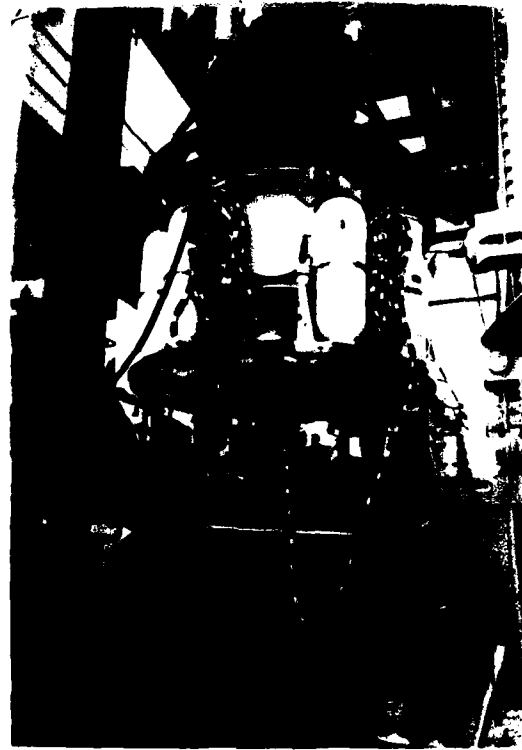

Figure 13-5 DDS MK2—Personnel Transfer Capsule

gases. All of the major units and their arrangements are shown in Figure No. 13-6.

Personnel Transfer Capsule 13.6.1

GENERAL 13.6.1.1 The Personnel Transfer Capsule (PTC), shown in Figure Nos. 13-5 and 13-7, is a submersible capsule capable of transferring four divers in full diving dress, with necessary work tools and associated operating equipment, from the deck of a ship to a maximum working depth of 850 feet while maintaining the required pressurized environment. The PTC consists of an elongated spherical hull with an access trunk with internal and external hatches, support frame, gas system, electrical system, visual and audio communications system, and divers platform. The PTC is designed to operate with an internal pressure of 378 psi when fully charged. It is also capable of withstanding the full differential pressure externally and can therefore be used as an observation chamber (with removable external hatch installed) at maximum working depth with an internal pressure of one atmosphere. In this mode the PTC is used only for observation with divers and/or observers remaining inside the capsule.

HULL 13.6.1.2 The PTC spherical hull is fabricated of welded HY80 steel and has an outside diameter of 84 inches. A 40-inch diameter cylindrical trunk, welded to the bottom of the sphere, provides for ingress and egress of personnel and equipment. Its lower flange is the mating flange between the PTC

**TABLE 13-1 DEEP DIVING SYSTEM
MK 2 GENERAL CHARACTERISTICS**

Designation: U. S. Navy Deep Diving System (DDS)
MK 2, MOD 0, MOD 1

Configuration: A DDS MK 2 diving complex consists of two complete systems. The complex consists of 2 DDC's, 2 PTC's, 2 MCC's, 2 LS's, 2 SPCC's and winches. Data cited below is for each system.

Operating Depth (Maximum) –
850 FSW

Divers Supported—
One four-man team

Personnel Capacity (PTC)—
4 Men

Personnel Required (Min)—
17 Men (including divers) plus PTC handling crew

Modes of Use and Normal Submerged Endurance—
Observation (48-manhours)
Non-Saturation Diving
Saturation Diving (16-manhours @ max depth)

Construction –
Ship-Installed

Applicable Support Ships and Barges—
DTV Elk River (MK 2, MOD 0)
ASR-21 Class (MK 2, MOD 1)

PTC Utilities—Self-contained gas supply; plus surface umbilical
Self-pressurizing to 200 FSW (MOD 0), 500 FSW (MOD 1);
Power and communications via SPCC; onboard emergency gas and power supply;
Hot water heating (surface-supplied hose) of PTC interior.
Electric resistance heaters (MOD 1)

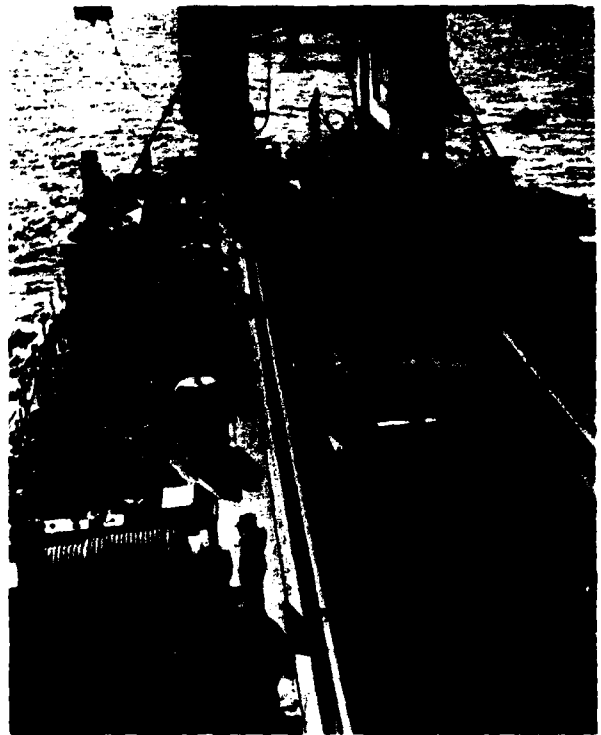

Figure 13-6 DDS MK 2 aboard the IX501.

Major Components and Overall Size—

Personnel Transfer Capsule—One Each
–Height—117 in.
–Width—85 in.
–Volume—240 cu. ft.
–Weight—26,000 lbs.

Deck Decompression Chamber (Overall)—One Each

–Length—314 in., diameter—80 in.
–Weight—39,500 lbs.
–Volume (inner lock)—750 cu. ft.
(outer lock)—250 cu. ft.

OTHER System Components Not Itemized

Operating Manuals:

Deep Dive System MK 2
NCSL (Panama City) TM
–Diver Communication System—DDS MK 2 MOD 0
NCSL (Panama City) TM
–PTC/Diver Water Heating System—DDS MK 2 MOD 0

Training Manuals—
NAVPERS

Deep Diving System MK 2 MOD 0
–Trainee's Guide
NAVPERS 94495
–Trainee Guide for Deep Diving System MK 2 MOD 1

Note—The DDS MK 2 MOD 0 and MOD 1 are essentially the same. The MOD 1 incorporates improved DDC hatches, viewpoints, PTC communications, PTC gas supply, and oxygen monitoring system.

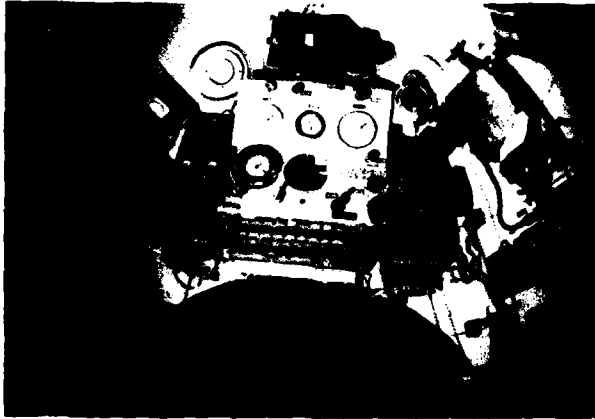

Figure 13-7 DDS MK 2—PTC interior

and transfer trunk of the Inner Lock of the DDC. The hull is reinforced locally to provide for eight viewports and a lifting eye. Also, a 12" wide straight cylindrical section is located between the two hemispherical heads of the sphere. An upper and lower protective bumper ring circle the hull horizontally to protect the electrical and gas connections. Six exterior lights and two underwater television cameras (one portable) are secured to the external framework surrounding the pressure hull. The interior of the hull is equipped with control panels and mechanical controls for the operation of electrical and life support systems. A lifting eye installed on the interior overhead permits divers to use a block and tackle to haul objects into the PTC through the trunk. The internal deck of the PTC consists of a circular metal plate shelf surrounding the hatch.

HATCHES 13.6.1.3 The access trunk is fitted with a permanent internal hatch and a removable external hatch for hydrostatic dives.

- Internal hatch**—The internal hatch located at the top of the trunk, opens inward and seals with internal pressure. It is spring counterbalanced for easy operation.
- External hatch**—A separate external hatch assembly is provided that may be attached to the mating

flange at the bottom of the access trunk. This pressure sealing hatch must be removed prior to any operations requiring mating of the PTC and DDC.

SUPPORT FRAME 13.6.1.4 The upper and lower bumper ring assemblies provide mounting points for ten 6-cubic-foot 3000-psi gas flasks (MOD 1, 5 each MOD 0) and associated piping and manifolds, battery container, transformer container, hookah hoses and hangers, suit heating cables, exterior lights, and TV cameras. Bumper cushions are fitted to the outboard surface of the framework's two main rings for protection purposes. The gas flasks, transformer container, and battery container are mounted vertically between the two bumper rings and are strapped in position. This framework terminates above the bottom face of the transfer trunk to permit PTC attachment to the escape hatch of submarines. Consequently, the PTC cannot be placed directly on deck for servicing. A separate stowage stand is used to support the PTC when attaching and detaching the external hatch and downhaul winch.

ANCHOR 13.6.1.5 The PTC anchor may be any suitable clump or explosive anchor having holding power from 2,000 pounds to 10,000 pounds, depending upon the operational situation (i.e. current, sea state, mission type, etc.)

GAS SYSTEM 13.6.1.6 The self-supporting PTC gas system consists of all the gas handling and monitoring components (flasks, piping, gages, valves, etc.) required to independently sustain 4 divers for a normal eight-hour mission (30 hours in an emergency). Helium, oxygen, and helium-oxygen mix are supplied by ten externally-mounted flasks (MOD 1, 5 each MOD 0) and one internally-mounted emergency oxygen flask. Internal pressure, gas-supply pressures, and PTC depth are continuously monitored. The system contains metabolic oxygen addition and a carbon-dioxide scrubber system which are used by the crew to control the breathing atmosphere.

- **Control equipment**—Color-coded and numbered valves at internal and external locations on the PTC provide for control of all gas system functions.
- **Oxygen system**—The PTC oxygen system consists of one 6.0 cubic-foot-volume externally mounted flask, one 0.35-cubic-foot-volume internally-mounted oxygen flask, and associated valves, piping, and fittings. The externally-mounted oxygen flask provides oxygen makeup inside the PTC for four divers for a maximum duration of 22 hours. The smaller internally-mounted flask is used to supply emergency makeup oxygen to the PTC interior for 10 hours per man, in the event of failure of the externally-mounted flask.
- **Helium system**—The PTC helium system consists of five 6.0-cubic-foot-volume externally-mounted flasks (MOD 1, 2 each MOD 0), and associated valves, piping, and fittings. The helium system is designed to self-pressurize the PTC and purge oxygen from all PTC electrical units to alleviate any fire hazard. The system contains sufficient helium to charge the MOD 1 PTC interior from one atmosphere to 282 psi (600 feet) without affecting mission capabilities.
- **Helium-oxygen mix system**—consists of five 6.0-cubic-foot-volume helium-oxygen mix flasks (MOD 1, 2 each MOD 0), an internal built in mask breathing system (BIBS) and associated valves, piping, and fittings. The mix system supplies breathing gas (helium-oxygen mixture) to the diver umbilicals for use outside the PTC. In addition, breathing mix is supplied to the BIBS in the event of contamination of the internal atmosphere. Provision is also made for supplying diver breathing gas via umbilical from the surface.
- **Vent and environmental monitoring system**—consists of a combination of gases and valves to control and regulate internal pressure of the PTC. A relief valve, set at 416 psi, and a manual vent valve prevent over-pressurization of the PTC in the event of a line rupture causing full flask discharge into the PTC. A needle valve is employed to control depressurization. A sea-pressure gage, calibrated in feet of seawater, monitors PTC depth, and a caisson gage indicates internal pressure. A transducer provides readout of depth and PTC internal pressure to

the Main Control Console (MCC). Equalization and vent valves are also provided for the access trunk. A 0 to 100 psig differential gage, calibrated in feet of seawater, provides monitoring control during depressurization.

- **Carbon dioxide scrubber system**—The CO₂ removal system consists of two scrubber assemblies, each assembly having a replaceable canister filled with CO₂ removal material. The main unit of a scrubber assembly is the blower/transition chamber. The centrifugal blower is mounted on the discharge end of the chamber and is driven by a 31.5-volt AC induction motor. A canister assembly, fabricated from stainless steel, fits into the inlet end of the chamber. Canisters are filled with CO₂ absorbent (48-manhours duration) and are fitted with screens at both ends. An armablu felt filter at the canister discharge end prevents the transfer of dust from the absorbent material to the PTC atmosphere. The second scrubber assembly is reserved for emergency use.

- **Instrumentation**—Instrumentation in the PTC is designed to insure safe conditions for the divers at all times and to provide an optimum degree of comfort. The partial pressure of oxygen is monitored and controlled automatically. An independent O₂ analyzer and O₂ control system is also provided. Another analyzer monitors CO₂ level. Oxygen measurements are transmitted to the MCC through the SPCC in addition to internal, external and differential pressure readings.

ELECTRICAL SYSTEMS 13.6.1.7

- **Primary electrical system**—Primary electrical power for normal operation of the PTC is surface-supplied and transmitted to the PTC through the Strength-Power-Communication Cable (SPCC) at 450-volt, 3-phase, 60-Hertz. A harness directs the power wires to an oil-filled, pressure-compensated, circuit breaker container on the exterior of the PTC. The circuit breaker container provides power to the oil-compensated transformer control module.

Within the module a 440V/120V 3 ϕ stepdown transformer provides power to the helium-purged 120V circuit breaker panel in the PTC. A separate transformer/rectifier unit supplies 28V DC to the helium-purged low voltage panel within the PTC. All noncritical electrical components including exterior lights, normal interior lights, and helium speech amplifier are powered from the 120 volt panel. The 28V DC panel supplies all components which must operate in an emergency involving loss of primary power. These components include an internal emergency light, ppO₂ monitor and control, CO₂ scrubbers, depth transducer, downhaul winch controls and explosive device control panel. With all PTC electrical systems energized, 34 kw of primary power is required.

—**Secondary electrical system (emergency)**—A 28-volt nickel-cadmium battery pack provides secondary power for emergency operation of necessary services in the event of loss of primary power. The batteries are housed in an oil-compensated container on the exterior of the PTC. It provides power to a transfer panel which in turn supplies the 28 VDC panel. It can be charged when the PTC is on deck of the support ship. A self-powered, flashing signal beacon on the top of the PTC can be actuated from inside for locating purposes.

COMMUNICATIONS (AUDIO AND VISUAL) 13.6.1.8

The PTC communications system is part of the overall communication system for the Deep Diving System MK 2. The system is divided into five individual systems to ensure efficient operation under a variety of conditions.

—**Hard-wire intercom system**—The intercom system is an amplified voice system employing a helium unscrambler which provides communications within the PTC, between the Main Control Console, the divers, the deck winch operator, Deck Officer, and Deck Decompression Chambers.

—**Underwater Mobile Sound Communication Set (UQC)**—The UQC system is an emergency system

providing voice communications between the PTC and the underwater telephone system of the attending ship. The UQC system is designed for use in event of failure or disconnection of the SPCC.

—**Closed-Circuit Television (CCTV)**—consists of two video channels from the PTC to the MCC. Both cameras are normally mounted outside the PTC. One camera looks through an upper viewport into the PTC at the control panel circuit breakers and gages. The second camera is portable and used for transmitting pictures of the work site. Video signals from both cameras are transmitted via the SPCC.

—**Sound-Powered Phones**—The PTC is equipped with an SP phone system for audio communications to the MCC in the event of loss of the normal audio system. The system consists of a control panel, handset and a headset. The control panel contains a phone call switch, an alarm switch and an incoming phone call light.

Strength-Power-Communication Cable and Deck Winch 13.6.2

STRENGTH-POWER-COMMUNICATION CABLE (SPCC) 13.6.2.1 The SPCC is a 1,400-foot armored, torque balanced composite cable which acts as a strength member to raise and lower the PTC from the maximum working depth, and which conducts electrical power, wired communications, instrumentation signals and coaxial transmission (CCTV signals) between the MCC and the PTC. The SPCC terminates in a mechanical breakout which is secured to a lifting eye on top of the PTC.

SPCC DECK WINCH 13.6.2.2 The deck winch, Figure No. 13-8, consists of a winding drum for receiving and stowing cable, level winding device for receiving cable on the drum, slip ring assembly capable of transmitting electrical signals and power from rotating ends of the cable to the PTC, and a drive to turn and control the winch. In addition, the winch is equipped with brakes, remote controls and performance monitoring gages to ensure proper control of

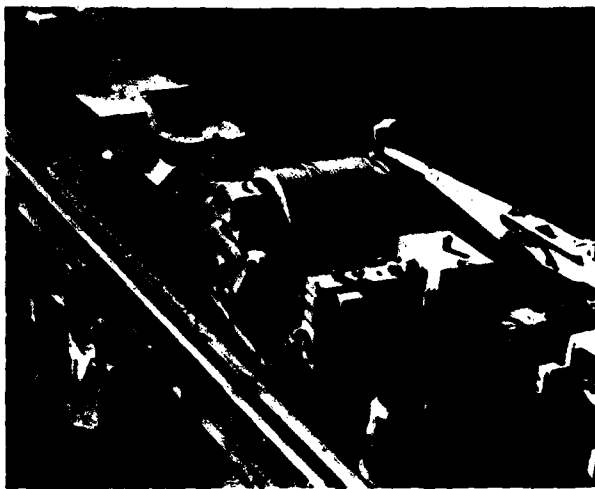

Figure 13-8 DDS MK 2—SPCC winch

winch actions. The winch is hydraulically driven in the normal mode and is equipped with an emergency air motor back up drive.

Deck Decompression Chamber 13.6.3

GENERAL 13.6.3.1 The deck decompression chambers, Figure Nos. 13-9 and 13-10, provide a pressurized environment to maintain off-duty living for two teams in a saturated pressure state thus eliminating the need for decompression at the termination of each dive. Each chamber is equipped with the necessary living, sanitary, and rest facilities for four men. In addition, the decompression chambers are used as the primary means to affect decompression. The deck decompression chamber consists of an inner lock (IL), outer lock (OL), medical lock and transfer trunk. The transfer trunk and medical lock are built into the inner lock which is the primary living compartment of the DDC. The outer lock is employed for the pressurization and transfer of medical and other personnel into and out of the inner lock and also houses the sanitary facilities for the DDC. In normal operation the inner and outer locks are maintained at the same pressure to permit full use of facilities by DDC occupants.

CHAMBER CONSTRUCTION 13.6.3.2 Each DDC is a four-lock pressure chamber designed to withstand an internal pressure of 378 psig (850 feet of sea water). The main structure of the chamber is cylindrical and measures 7 ft. 6 in. in diameter and is 24 ft. 1 1/4 in. long. It consists of two cylinders welded together with a transition ring between the two cylinders that forms part of the inner lock head. The ends of the chamber consist of elliptical dished heads welded to the main structure. The three main cylindrical sections, dished heads, and hatches are formed from HY-80 steel plate. The two dished heads at the chamber entrance end have reinforced center hatch-

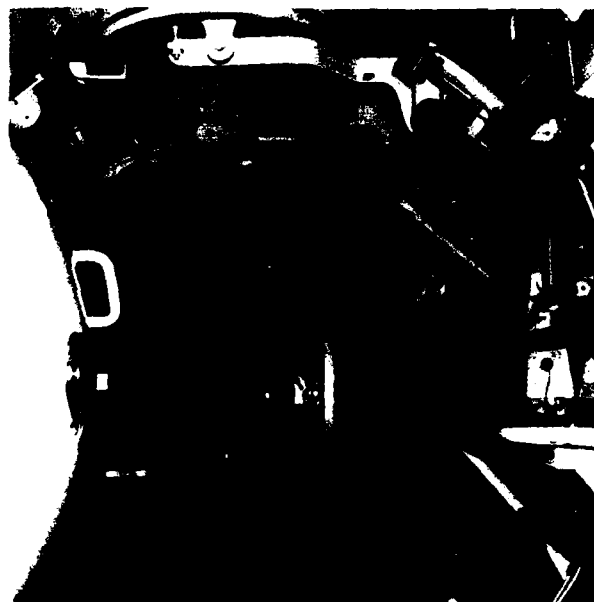

Figure 13-9 DDS MK 2—Deck Decompression Chamber Inner Lock Interior

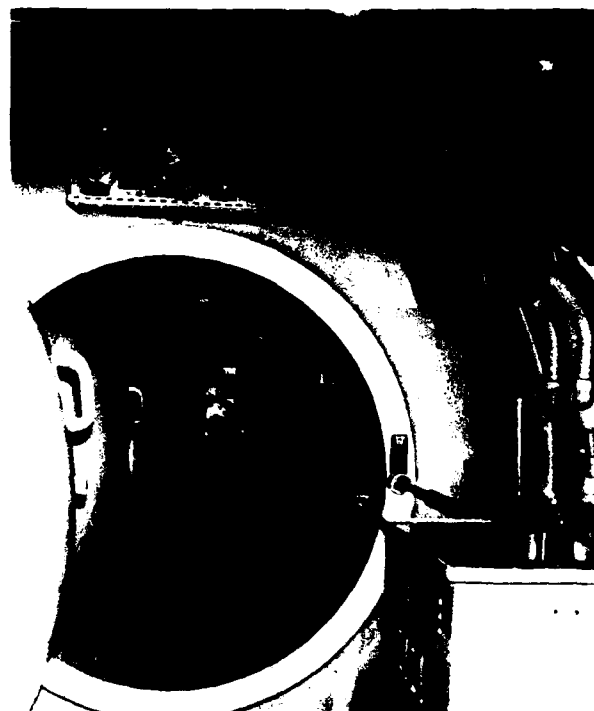

Figure 13-10 DDS MK 2—Deck Decompression Chamber Out Lock Interior

ways 3 ft. 6 in. in diameter. These hatchways are fitted with hatches, which contain sealing gaskets. The upper portion of the chamber is fitted with a transfer trunk and a transfer hatch to permit personnel transfer between the DDC and the PTC. To aid in personnel transfer, a short section of ladder is attached to the inside of the transfer trunk which aligns with the main ladder. The main ladder provides access to the transfer trunk from the DDD deck. The ladder is

covered by a section of decking when it is not being used. The hatch is supplied with pressurized fresh water as a hydraulic fluid. The bottom of the chamber is fitted with a deck 4 ft. 10 in. wide throughout its length. Eight 6 in. viewports are installed for direct and CCTV viewing of the occupants.

INNER LOCK 13.6.3.3 The inner lock end of the chamber is fitted with a service/medical lock 17 inches in diameter and 23 inches long for the purpose of passing small articles, medical supplies and food into and out of the chamber. It is fitted with inner and outer doors and is supplied with pressurizing gases. The inner lock of the DDC is divided into two compartments by a nonstructural louvered partition. The compartment adjacent to the medical lock is used for sleeping and contains four submarine-type bunks and lockers for storing personal effects. All drawers and lockers are provided with vent holes to prevent gas entrapment. The remaining area of the inner lock forms the living compartment, and it is fitted with a table to permit eating and recreational or work activities for four persons at one time. The table may be folded partly out of the way when required.

OUTER LOCK 13.6.3.4 The outer lock of the DDC serves as an independent pressure facility which may be held at a different but lower pressure than the inner lock. Included in the outer lock are all the necessary sanitary facilities for a diving team including a flush-type water closet, a lavatory, a mirror, a shower, and small storage cabinets. The deck of the outer lock serves as the catch area for the shower and is fitted with a drain and trap.

GAS SYSTEMS 13.6.3.5 The DDC gas system provides oxygen, helium-oxygen mixtures, helium and air for pressurization and life support of divers. An oxygen/He-O₂ mixture breathing mask manifold, for each lock, accommodates 6 emergency masks (BIBS) each. Pressurizing or depressurizing of the DDC is

normally done from the MCC. Externally-mounted gas admission and exhaust control panels are provided for local use. Two life support systems consisting of a flow meter, CO₂ scrubber, blower and motor, dehumidifier, demister, reheater, and filter are controlled by the life support console. A means of sampling the internal atmosphere is provided for monitoring of CO₂ and oxygen partial pressure. An automatic oxygen addition system maintains oxygen partial pressure at preset levels. Manual override is provided in the MCC, and a manual control is provided on the chamber. A pressure relief system prevents over-pressurization of the chamber.

LIQUID SYSTEMS 13.6.3.6 The sanitary liquid system for each chamber consists of hot and cold water supply for operation of the wash basin, shower, water closet, and fire hose. Wash basin and shower waste water empty into a common sump and are discharged by chamber pressure to a waste-holding tank. Waste from the water closet discharges directly into the holding tank. The holding tank discharges directly into the ship's waste system. A 40-gallon water tank, automatically filled and pressurized by ship's high pressure air, supplies the interior fire hoses for each lock.

COMMUNICATIONS AND INSTRUMENTATION

13.6.3.7 Two electrical panels, one in the inner lock and one in the outer lock, contain a caisson gage, intercom speaker and switch, sound-powered phone call light and pushbutton, emergency alarm pushbutton, helium speech unscrambler microphone, two handsets, entertainment speaker, sound-powered phone jacks, and two ppO₂ sensors. Three externally-mounted CCTV cameras monitor occupants in each chamber.

Main Control Console 13.6.4

Each of the two Main Control Consoles (MCC), Figure

No. 13-12 functions as the central control and monitoring area for its half of the diving system. This includes: gas supply to the DDC; atmosphere analysis and control for the DDC inner and outer locks; atmosphere monitoring for the PTC; pressure gages for gas banks and gas lines, and for DDC inner and outer locks; digital clock; communications system controls; instrumentation readouts; power supplies and power controls; and closed-circuit TV monitors and switches for the DDC and PTC. The two MCCs have a number of communication cross ties which include those for the intercom system, sound-powered phone system, closed-circuit TV, tape recorders and helium speech unscramblers. The audio cross ties provide the following additional capabilities: (1) permits the use of both helium speech unscramblers simultaneously; (2) permits both tape recorders to be used together to provide an 8-channel recording capability; and (3) permits scrambled audio to be played back, processed, and then recorded as unscrambled audio. The following control actions are not performed at the MCC: shipboard handling and raising and lowering of the PTC's, PTC gas flask charging, PTC battery charging, operation of the life support systems, helium recovery system operations, PTC-DDC mating, DDC hatch and DDC service/medical lock operation.

Life Support System 13.6.5

There are two DDC Life Support Systems (LSS) in the DDS MK 2, one for each DDC. Each system consists of a life support console and associated piping and valves, filters, gages, blowers, temperature and humidity sensors, carbon dioxide absorbers, heat exchangers, mist eliminators, and flow meters.

The function of the LSS is to circulate and process the DDC atmosphere so that relatively impure gas is replaced with purified gas of the proper temperature and humidity. Processing consists of filtration to remove particular matter, absorption to remove CO₂ and odors, and separation to control moisture. The components and associated piping that make up the LSS are not mounted in a separate enclosure but are grouped together in the MCC area.

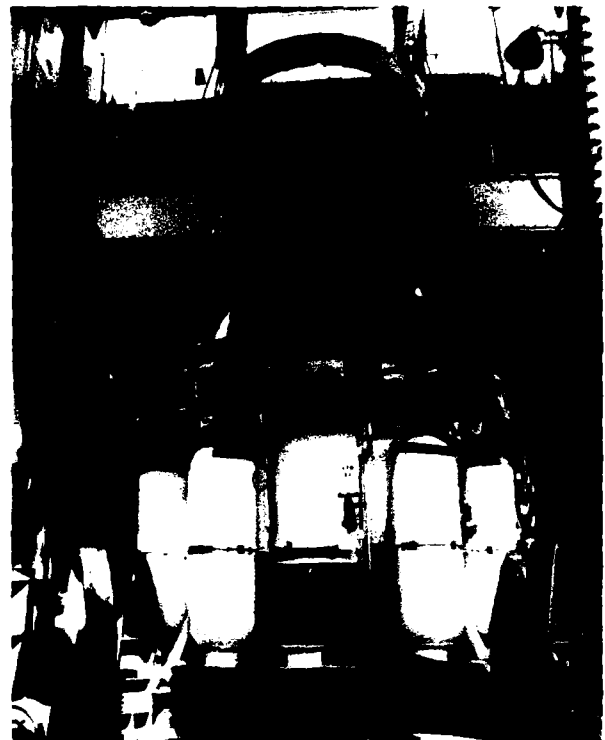

Figure 13-11 DDS MK 2—PTC being mated to the DDC located below deck.



Figure 13-12 DDS MK 2—Main Control Console

Each system is broken down into two loops with one loop serving the inner lock and the other loop serving the outer lock. The use of two life support loops for each DDC provides for operational flexibility and redundancy since the two loops can be cross-connected by opening or shutting the appropriate valves. Normal operation involves running one loop for the entire DDC, with the capability of using both loops during periods of peak demand or when using the locks separately. During normal operation, the one idle system may be serviced or repaired as needed.

Operational Data 13.6.6**PERSONNEL TRANSFER CAPSULE**

Manufacturer Hunters Point Naval
 Shipyard; Dixie
 Manuf. Co.

Material HY80 Steel

Construction Welded

Dimensions—

— Outside diameter at
equator 84 in.

— Overall Height (without
External Hatch) 121 in.

— Overall Outside Diameter 126 in.

— Trunk diameter 40 in.

— Trunk length 18 in.

Operating temperatures—

— In air 20° F to 120° F

— In water 29° F to 90° F

Gas flasks—

— Helium (He)

Quantity 5

Volume (cubic feet
water volume) 6 CFWV

Pressure 3,000 psig

— Helium-oxygen mix
(He-O₂):

Quantity 4 (MOD 1); 2 (MOD 0)

Volume (cubic feet
water volume) 6 CFWV

Pressure 3,000 psig

— Oxygen

Quantity 1

Volume (cubic feet
water volume) 2.8 CFWV

Pressure 3,000 psig

— Emergency oxygen

Quantity 1

Volume (cubic feet
water volume) 0.35 CFWV

Pressure 3,000 psig

Anchor—

— Type Concrete clump

— Weight Maximum 2,500 lb.

**Maximum operating
pressure—**

— Internal 378 psig

— External (850 feet depth) 378 psig

Electrical power—

— Surface supplied
(through SPCC) 440v, 3 ϕ , 60hz

— Emergency (on-board
batteries) 28v, DC

CO₂ scrubbers—

— Number 2

— Type Absorbent

**Underwater Breathing
Apparatus (UBA)—**

— Quantity 4

— Type MK 1

— Umbilical length 150 ft.

**Emergency Mask Breathing
system (BIBS)—**

— Quantity 4

STRENGTH-POWER-COMMUNICATION CABLE

Manufacturer

Simplex Corp.

Type construction

Composite, double
layer galvanized
armor wise

Dimensions—

— Overall diameter 2 in.

— Overall length 1,454 ft.

Min. Bending Radius
(Armored) 30 in.

Breaking strength 160,000 lbs.

Weight—

— In air 4,435 lb./1,000 ft.

— In seawater 3,085 lb./1,000 ft.

**Electrical and
communications
conductors—**

— No. 10, stranded-wire
conductors 9

— Multistrand coaxial
cables— type RG-59/U 3

— No. 18, shielded single
conductors 12

— No. 18, shielded
conductor pairs 12

SPCC DECK WINCH

Manufacturer Western Gear
Type Hydraulic with separate Power Unit
Drum diameter 60 in.
Drum capacity (2.06 in SPCC) 1,523 ft.
Line speed 0 to 100 fpm
Maximum rated load @ 10 fpm or less 30,000 lb.
Load at maximum line speed 3,000 lb.

Winch assembly—

—Dimensions (overall)
 Length 130 in.
 Height 88 in.
 Width 138 in.
 —Weight 25,000 lb.

Hydraulic power unit assembly—

—Dimensions (overall)
 Length 60 in.
 Height 51 in.
 Width 40 in.
 —Weight 4,000 lb.

Control console assembly—

—Dimensions (overall)
 Length 36 in.
 Height 62 in.
 Width 28 in.
 —Weight 500 lb.

Power requirements 440v AC, 3 ϕ , 60hz, 42 Amp, 120v AC, 1 ϕ , 60hz, 20 Amp

Indicators—

—SPCC Line Tension
 —SPCC Line Speed
 —SPCC Footage Counter

DEEP DIVING SYSTEMS

MAIN CONTROL CONSOLE

Type Integrated, U-shaped
Dimensions (overall)—
 —Length 150 in.
 —Depth 66 in.
 —Height 78 in.
Weight 15,000 lb.
Power requirements 120v AC, 3 ϕ , 60hz, 10kw; 120v AC, 1 ϕ , 60hz, 6kw
Ship's Service Gas air, helium, oxygen, helium-oxygen

Instruments—

—Speaker and Alarm Panel (Amplifier) RCA, AM-2158 A/WIC
 —Helium Speech Unscrambler Integrated Electronics Corporation
 —Tape Recorder Ampex
 —Intercommunications Panel (Amplifiers) RCA, AM2118A/WIC, AM4760/WIC-2A
 —Video Monitors RCA
 —Video Switchers RCA
 —Digital Depth Indicators Monsanto
 —Digital Clock Monsanto
 —Ground Detector (120 VAC) Crouse-Hinds
 —28-Volt Power Supply Sorensen
 —pO₂ Remote Meter, Unit 2 Beckman/Bio Marine
 —pO₂ Control, Unit 1 Beckman/Bio Marine
 —pO₂ Control, Unit 3 Beckman/Bio Marine
 —Temperature Indicator Bristol
 —pCO₂ Meter Beckman
 —TV Camera Power Supply Hydro Products

Manufacturer—

RCA, AM-2158 A/WIC

Integrated Electronics Corporation

Ampex

RCA, AM2118A/WIC, AM4760/WIC-2A

RCA

RCA

Monsanto

Monsanto

Crouse-Hinds

Sorensen

Beckman/Bio Marine

Beckman/Bio Marine

Beckman/Bio Marine

Bristol

Beckman

Hydro Products

13-27/(13-28 Blank)

CHAPTER FOURTEEN

OXYGEN DIVING OPERATIONS

Although 100% oxygen is used as a breathing medium as an adjunct to decompression in several diving procedures, its use is limited to situations in which the diver is at rest. The use of 100% oxygen for breathing during working dives is generally limited to shallow water operations because of the significant hazard of oxygen toxicity.



Figure 14-1 Diver preparing for an operational dive wearing an "Emerson Rig"

A closed-circuit oxygen SCUBA is used for oxygen diving in the U. S. Navy. This unit, officially designated as the **Recirculating Underwater Breathing Apparatus, Closed-Circuit, Oxygen** and commonly called an "Emerson rig" or "oxygen rebreather," is employed by combat swimmers (UDT, EOD, SEAL) for missions in which its bubble-free characteristics are essential for undetected approaches to objectives (Figure 14-1). The use of the USN oxygen SCUBA is restricted to personnel specially trained and qualified in its use and the hazards associated with this mode of diving.

OXYGEN DEPTH-TIME LIMITS 14.1

Exposure to oxygen, for 30 minutes at 60 feet is used as a routine oxygen tolerance test in selection of divers, and exposures of this depth and duration are

used in the treatment of decompression sickness. In decompression from helium-oxygen dives, oxygen is breathed at depths as great as 50 feet. **Such exposures are safe only if the diver is at rest.** This section concerns exposure limits for **working dives** in which oxygen is the breathing medium. These limits, established to provide safety from oxygen poisoning, anticipate exceptional operational requirements and emergencies as well as normal requirements.

The limits are divided into three categories defined as follows—

Normal Oxygen Limits—Based upon normal, uncomplicated daily requirements.

Exceptional Operations Limits—Sufficiently safe for exceptional operational requirements.

Emergency Limits—Experience with oxygen exposures beyond the normal and exceptional limits.

The potential results from oxygen poisoning at depth are so serious, and so many uncontrolled variables are present, that a relatively safe limit is necessary for normal operations. The effects that the amount of physical exertion and excess carbon dioxide have on controlling the onset of oxygen poisoning, along with other physiological factors, are explained in Chapter Nine. Review that entire section before diving with a high partial pressure of oxygen.

Normal Oxygen Limits 14.1.1 The normal limit is straightforward. When using oxygen as the breathing medium, **DO NOT DIVE DEEPER THAN 25 FEET** and stay within the time limits specified in Table 14-1.

Limits for Exceptional Operations 14.1.2 Provided that all other variables are optimum, tests indicate that short exposures at depths greater than 25 feet are safe. The diving officer may authorize use of the depth-time limits given in Table 14-1 for depths greater than 25 feet when he has weighed his operational objectives against the increased hazard and has taken all precautions possible.

Emergency Limit 14.1.3 Extraordinary situations, such as the requirement for an extremely important mission when oxygen is the only breathing medium that can be used, might dictate that an attempt be made to exceed the limits of Table 14-1. The following

TABLE 14-1 OXYGEN DEPTH-TIME LIMITS

(Depth and time limits of exposure for breathing pure oxygen during working dives)

1. Normal Operations—Depth		Time
(ft)	(ft)	(min)
10	10	240
15	15	150
20	20	110
25	25	75
2. Exceptional Operations—Depth		Time
(ft)	(ft)	(min)
30	30	45
35	35	25
40	40	10

BREATHING 100% O₂ DEPTH/TIME LIMITS

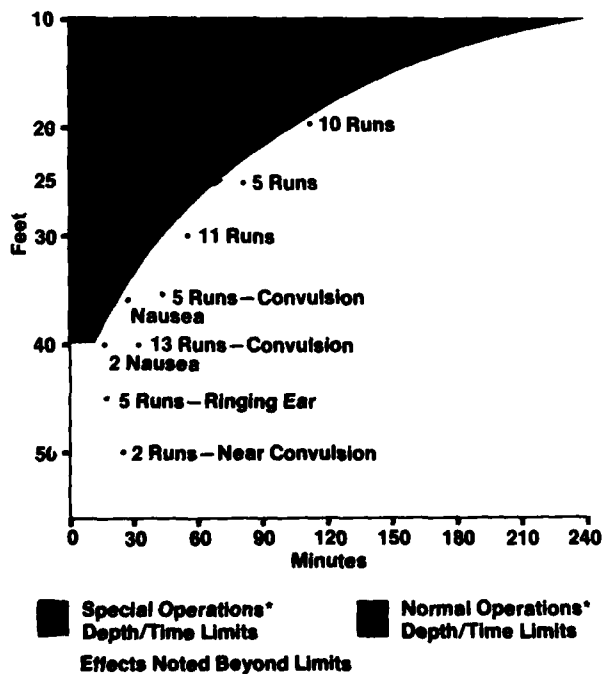

*Considered safe for dives involving moderate work with minimal CO₂ inspired gas.

Figure 14-2 Experimental exposures breathing 100%O₂

commentary may help in evaluating the chances for success under these extraordinary conditions.

Figure 14-2 shows the results of experimental exposures to pure oxygen at different depths for various times. The proximity of possible warning symptoms and even convulsions to the Important Operation Limit Curve is apparent. Less apparent is the contrast between the perfect conditions that existed during these exposures and the conditions that would probably exist in the field. The experiments were conducted in a pressure tank; the work rates were moderate and uniform; the inspired gas was free of carbon dioxide; and two tenders were standing by each subject. It is likely that exposure to oxygen at these depths for the same times under operating conditions would produce a much larger proportion of unfavorable effects.

The necessity to exceed exceptional operations limits in order to accomplish a mission must be brought to the attention of the officer assigning the mission, who must accept the responsibility for the increased hazard to personnel.

CLOSED-CIRCUIT OXYGEN SCUBA 14.2

The U. S. Navy oxygen SCUBA unit is a closed-circuit underwater breathing apparatus that consists of a mouthpiece-breathing valve assembly, breathing hoses, inhalation and exhalation breathing bags, a carbon dioxide absorption canister, an oxygen supply cylinder, and a manually adjustable gas-flow regulating assembly mounted on a nylon vest. Figures 14-3 and 14-4 show the oxygen breathing apparatus in position ready for use. The completely assembled apparatus weighs about 35 pounds out of water, and is approximately neutrally buoyant in use underwater.

Principles of Operation 14.2.1 The closed-circuit diving apparatus, employing carbon dioxide absorption, permits essentially complete utilization of the available gas supply at a rate independent of depth. Diving depth and duration are limited, however, by the physiological hazards from oxygen toxicity as previously discussed.

Compressed oxygen is delivered from the high-pressure oxygen cylinder into the breathing system at the inspiratory breathing bag by a manually adjustable

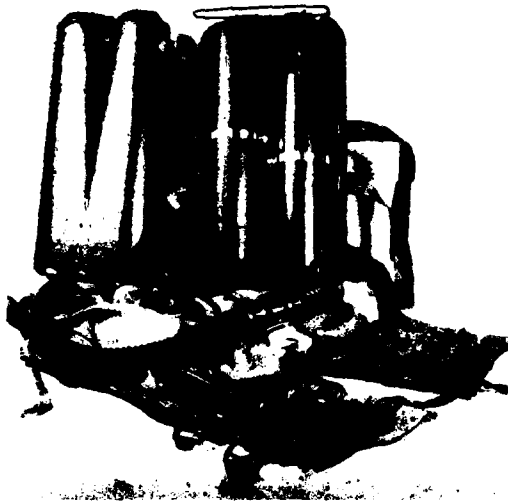

Figure 14-3 "Emerson Rig"

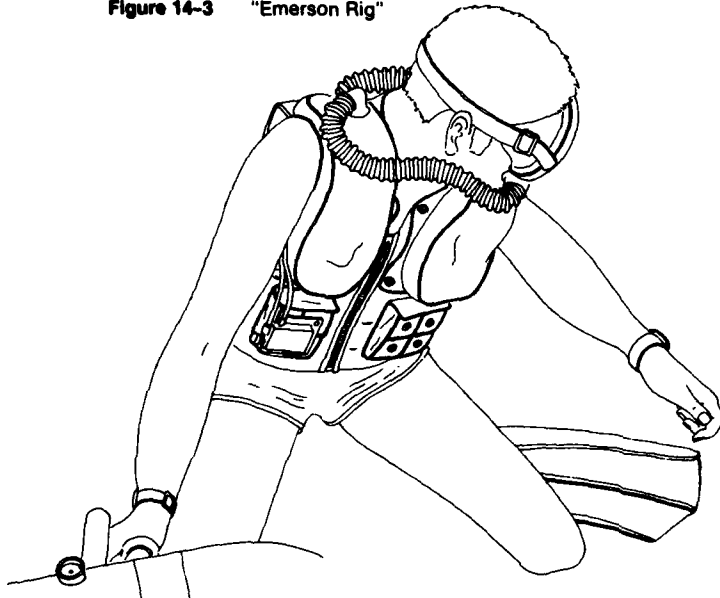

Figure 14-4 Diver fully outfitted with the Emerson O₂ SCUBA metering valve. Alternately, oxygen can be introduced by a manual bypass valve.

The flow of oxygen into the breathing circuit should be set to the rate at which the diver uses the oxygen. This flow is set by adjusting the metering valve of the waist valve assembly. Under average conditions the oxygen consumption and flow rate is set for 0.9 liters per minute. Oxygen consumption at other conditions is shown in Table 14-2.

Figure 14-5 shows a diagram of the rebreathing circuit. The diver holds the mouthpiece in place in his mouth and wears a facemask covering his eyes and nose, or he may wear an approved full facemask. Upon inhalation, the diver receives gas directly from the right-hand breathing bag through the right-hand inhalation hose and the inhalation checkvalve. On exhalation, exhaled gas (now containing carbon dioxide from the lungs) is prevented by the inhalation check-

TABLE 14-2—OXYGEN CONSUMPTION VS. WORK RATE

UNDERWATER ACTIVITY	OXYGEN CONSUMPTION (liters/min STPD)
Rest	0.5
Moderate Work	
– Swimming, 0.5 knot (slow)	0.9
Heavy Work	
– Swimming, 1.0 knot	2.0
Severe Work	
– Swimming, 1.2 knot +	3.0

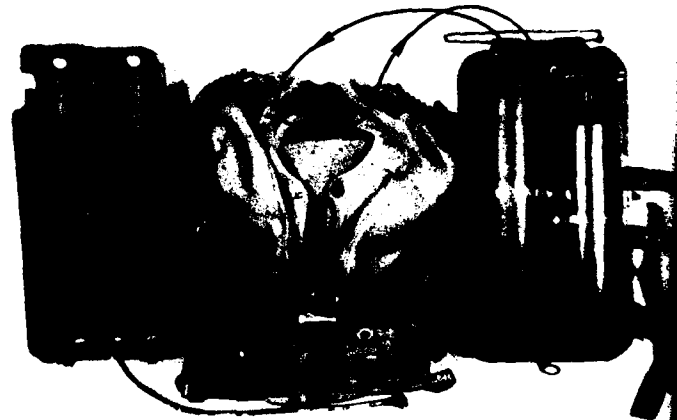

Figure 14-5 Arrows indicate rebreathing circuit

valve from passing back into the right breathing bag. Instead, it passes from the mouthpiece assembly through the exhalation checkvalve, and through the left-hand exhalation hose to the left breathing bag. As it enters the left breathing bag, the exhaled gas displaces gas from the left-breathing bag, causing flow into the carbon dioxide absorption canister, where the carbon dioxide is removed. Gas within the canister, now freed of carbon dioxide gas, is displaced into the right breathing bag, where it remains until the next inhalation.

Main Components 14.2.2 The oxygen SCUBA consists of the following four primary component groups—

CYLINDER, VALVE, AND REGULATOR 14.2.2.1

One 2,000 psi standard cylinder of 12.7-cubic-foot capacity, a constant-reserve valve set at 500 ± 50 psig and a regulator preset to 80 psig, delivers oxygen to the system.

BACKPLATE, COVER, AND CANISTER ASSEMBLY 14.2.2.2

The backplate, 22½ inches long by 12 inches wide, has hinges (for the shoulder pin) at its upper edge. It provides cradles for the cylinder (on the right side) and the CO₂ absorbent canister (on the left side). The cylindrical fiberglass container has two quick-connect hose fittings, a low-pressure relief valve set at 3.0 ± 0.5 psig, and a removable cover and inside shell. The backplate cover has two ears at its lower edge and a latch at its upper edge. The cover protects the regulator and canister. It also streamlines the unit for minimum resistance, and aids in preventing entanglement.

VEST, BREATHING BAGS, AND MOUTHPIECE ASSEMBLY 14.2.2.3

A vest with two detachable bags supports the backplate assembly. The vest is nylon. The breathing bags have a three-layer construction with cotton on the exterior and interior surfaces and a gas-tight rubberized center. The mouthpiece assembly, which contains the check-valves, is attached to the breathing bags by two breathing hoses.

WAIST VALVE ASSEMBLY 14.2.2.4 This valve is mounted on the front, lower right of the vest and incorporates the metering valve and bypass valve.

Cylinder, Valve, and Regulator 14.2.3 One cylinder is provided to contain oxygen for use in diving. The cylinder is rated for filling to 2,000 psig and has a capacity of 359.6 liters when full (12.7 cu. ft.). Theoretically, the full cylinder contains sufficient oxygen for almost 6 hours' use during moderate work (oxygen consumption rate = 1 lpm). With an adequate safety factor and assuming that above average work rates will be periodically encountered, the practical duration of the apparatus is 120 minutes. The con-



Figure 14-6 Proper position of Emerson Rig on Diver

stant-reserve valve is set for one-fourth of the cylinder pressure (500 ± 50 psig). Pay special attention to the note in Section 14.8 regarding the operation of the constant-reserve valve.

In position, the cylinder is mounted vertically on the diver's back with the neck of the cylinder up, as shown in Figure 14-6. In respect to the diver, the cylinder valve handle extends through the cover near the right shoulder, and the constant-reserve valve rod extends through the lower center of the cover.

The regulator, shown in Figure 14-7, is attached to the higher-pressure cylinder by a standard yoke fitting. The outlet fitting provides a connection for the low-pressure, flexible gas-delivery hose to the re-breathing system. A relief valve is installed in the low-pressure side of the regulator.

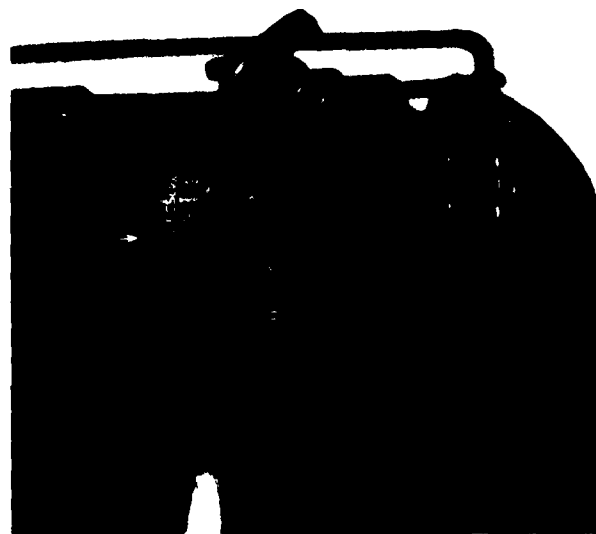

Figure 14-7A Detail of cylinder valve, yoke and regulator assembly.

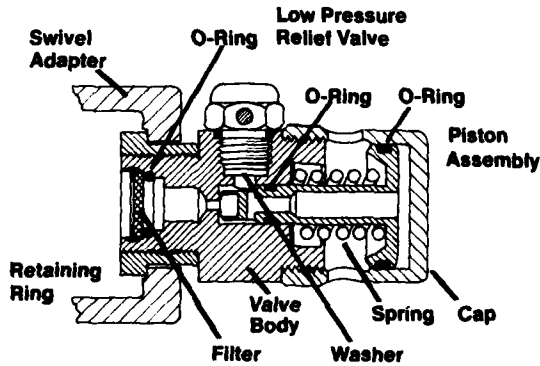

Figure 14-7B Regulator cross-section

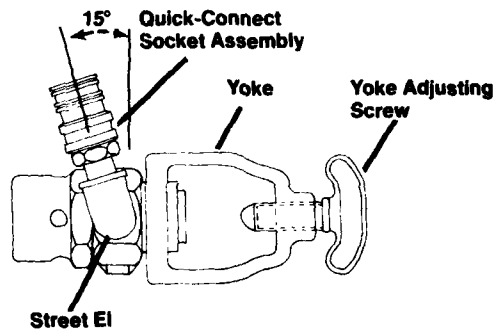

Figure 14-7C Standard yoke fitting

The regulator is a depth compensating, nonadjustable, piston-type. The body contains the filter, high and low-pressure porting, output connection, and relief valve. The bonnet, which has a threaded connection to the body, contains the piston and spring. The regulator is preset for an 80 ± 8 psig output. The relief valve is set to relieve at 300 ± 50 psig.

Dimensions of the cylinder with the valve and regulator: length, 19 inches; diameter, $4\frac{3}{4}$ inches; weight, 10 pounds.

Backplate, Cover, and Canister Assembly 14.2.4

The fiberglass backplate (Figure 14-8) provides a rigid mount for the oxygen supply system and CO₂ removal canister. These components are secured in position in their respective cradles by clamps.

The backplate is secured to the vest by a long removable shoulder pin which passes through two loops at

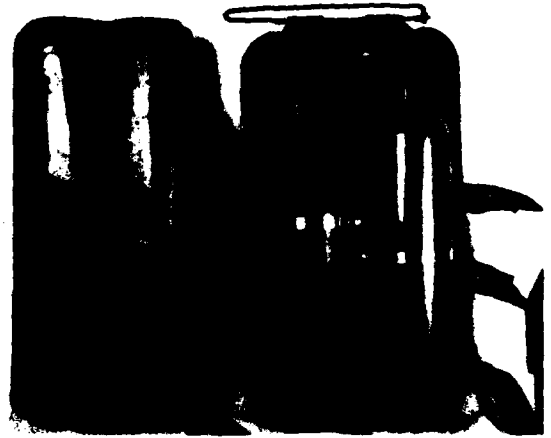

Figure 14-8 Backplate and cover

the top of the backplate and three corresponding loops on the vest. The fiberglass backplate cover has two ears at its lower edge which engage into slots in the lower portion of the backplate. The cover has a latch at its upper edge which engages with the backplate to lock it into place.

The three-piece (outside shell, inside shell, cover) fiberglass carbon dioxide absorption canister assembly is mounted vertically on the left side of the backplate. The canister is cylindrical, and has an outside shell incorporating two quick-connect breathing hose fittings at its upper end and a removable cover at its lower end. Within the outside shell is a fiberglass inside shell which holds approximately 6 pounds of absorbent. The absorbent will remove carbon dioxide for approximately 30 minutes in 40°F seawater and 5 hours in 70°F water at average work rates. At the cover, or lower end of the inside shell, is a removable screen which is attached to the canister cover by a spring. A similar screen is also used at the upper end of the inside shell. The inside shell is held in place $\frac{3}{16}$ inch from the outside shell by six raised bosses on

its outer surface, and it is connected directly to one of the canister outlets by an O-ring seal. Thus, the gas passes between the inside and outside shells to the lower or cover end, and returns through the absorbent in the inside shell and out to the breathing bag (see Figure 14-9). The canister cover, equipped with an O-ring seal and a secondary flat-ring seal, is held in place by two cover-clamp thumbscrews which are permanently attached to the cover. The inside shell is removable for periodic cleaning and inspection.

There is an overpressure relief valve set at 3.0 ± 0.5 psig mounted in the top of the canister.

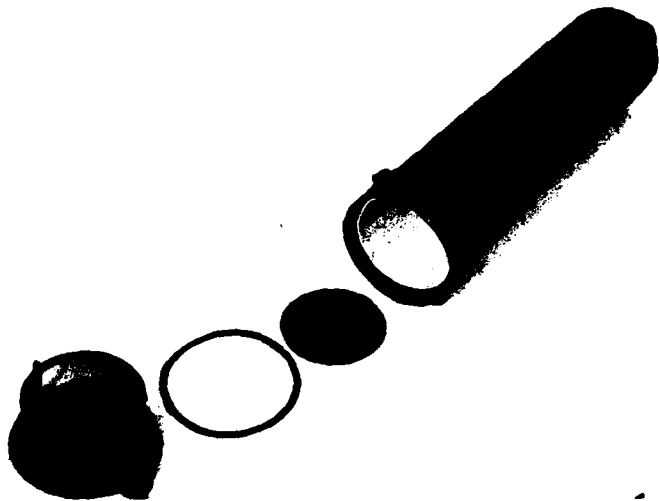

Figure 14-9 CO₂ absorption canister - disassembled

Vest, Breathing Bags, and Mouthpiece Assembly

14.2.5 The breathing apparatus components are supported on a vest. In use, the vest and backplate are secured in relation to the diver by the removable hinge pin in back of the shoulders and by three pairs of side straps.

In front, the vest is divided vertically in the midline and is provided with a nylon zipper closure for ease of donning and removal. A circular opening is provided for the head and neck. The breathing bags are removable from the vest and are located to the right and left of the midline closure. Below each breathing bag is a small weight pouch closed with flaps at the top and bottom by fasteners. Two-pound rectangular

weights are inserted in these pouches to achieve desired trim in the water. Figure 14-10 shows the breathing bag and vest assembly.

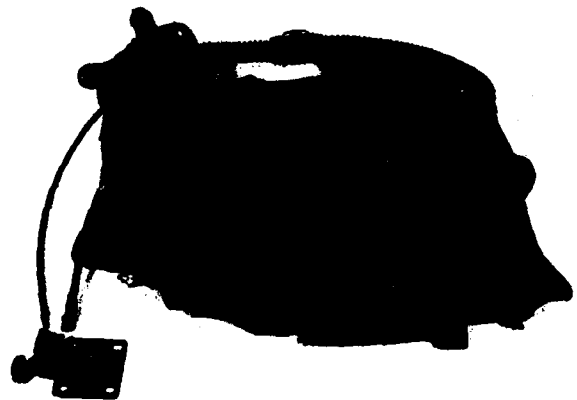

Figure 14-10 Breathing Bag - Vest assembly

Buckles at the lower side corners of the vest provide means for securing and adjusting the free ends of the side straps coming from the backplate.

The right and left breathing bags (Figure 14-5) are held in place on the vest by commonsense fasteners. Each bag extends from behind the neck, over the shoulder, and down over the upper portion of the chest. When inflated, the volume of each breathing bag is approximately 4 liters. Removable elbows are mounted on the front of each bag at about neck level for attaching the breathing hoses to and from the mouthpiece. A second pair of removable elbows extend from the back edge of the bags. These provide a means for conducting exhaled gas from the left breathing bag to the carbon dioxide absorption canister, and from the canister to the right breathing bag. An inlet for oxygen is permanently mounted on the right breathing bag. At the bottom of each breathing bag is a drain fitting with a chain plug-and-cap assembly. After use, the drains should be opened for condensate removal and for ventilation. This will preserve the breathing bags when the unit is stored.

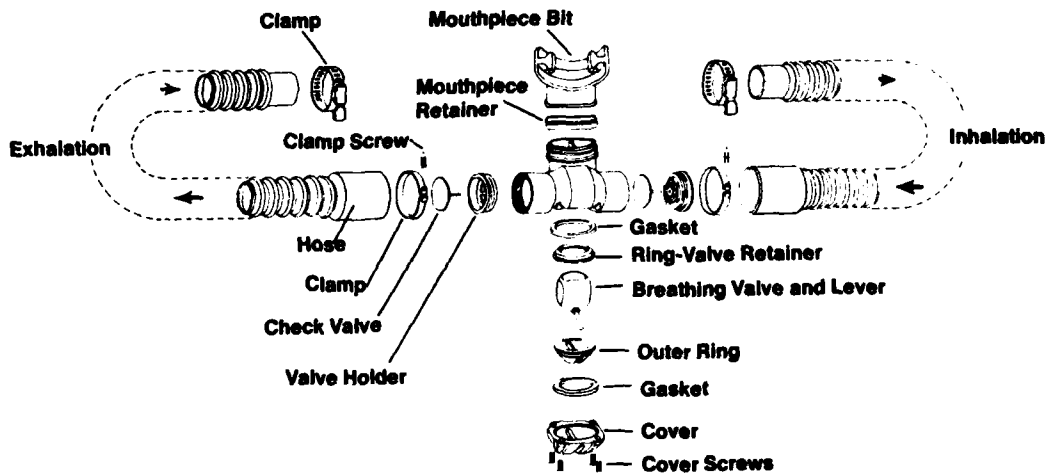

Figure 14-11 Exploded view of the mouthpiece assembly

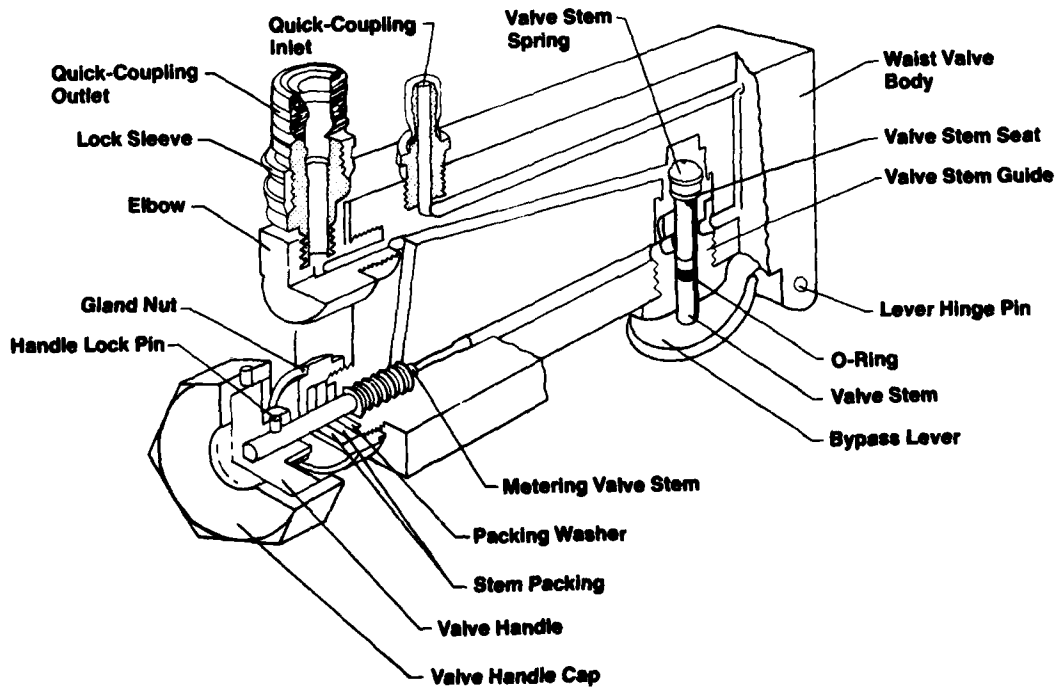

Figure 14-12 Waist valve assembly cut away



Figure 14-13 Detail of mouthpiece

Figures 14-11 and 14-13 show the mouthpiece breathing valve. The rubber mouthpiece bit is attached to the outer shell of a molded nylon mouthpiece body. The valve has a lever that protrudes through the cover and can be rotated to an ON position, which permits the wearer to breathe, or to an OFF position, which seals the circuit from the outside air or water.

An exhalation checkvalve and a molded nylon valve holder are located in the opening at the left end of the mouthpiece body. An inhalation checkvalve and valve holder are located at the right end of the mouthpiece body.

The mouthpiece breathing valve assembly is connected by appropriate fittings to the two breathing hoses. Each hose is 19 inches long with a 7/8-inch internal diameter.

Waist Valve 14.2.6 The low-pressure outlet of the regulator is connected by a flexible low pressure hose to the waist valve shown in Figures 14-12 and 14-14. Upon entering the valve, the oxygen has two flow paths available; one to the metering valve, and the other to the by-pass valve. Normally, oxygen entering the waist valve passes through the metering valve and out of the waist valve to the right-hand breathing bag. The metering valve handle has markings for flows of 0.5, 0.9, 2, and 3 liters per minute and has a maximum flow ranging from 3.5 to 4 liters per minute. When the by-pass valve lever is depressed, oxygen bypasses the metering valve and provides maximum flow directly to the right-hand breathing bag. The waist valve is secured to the supporting vest by four fasteners on the right-hand weight pocket.



Figure 14-14 Detail of waist valve

HANDLING AND ASSEMBLY 14.3

Although the underwater rebreathing apparatus is not fragile and is constructed to resist wear and damage in normal use, it should in all phases of assembly, use, handling, and storage be treated as equipment made for the support of life under adverse conditions. Therefore, this equipment must be treated with care.

Assembly of Components 14.3.1 The oxygen SCUBA should be carefully assembled using the following procedures—

CHECK COMPONENTS 14.3.1.1 The following components are required to assemble the apparatus—

- (1) Vest and backplate
- (2) Breathing bags
- (3) Mouthpiece assembly
- (4) Canister
- (5) Cylinder with constant-reserve valve
- (6) Regulator
- (7) Waist valve
- (8) Backplate and straps
- (9) Cover

VEST AND BREATHING BAG ASSEMBLY 14.3.1.2

Tighten the four elbow connections on the breathing bags (two on each). Secure the drain plug caps. Attach the breathing bags to the vest with the fasteners.

CYLINDER, REGULATOR, AND WAIST VALVE ASSEMBLY 14.3.1.3 Attach the regulator to the cylinder valve and tighten the yoke securely. Attach the waist valve inlet hose to the regulator by inserting the male quick-connect fitting (elbow) firmly into its receptacle on the regulator and securing the lock ring.

FINAL ASSEMBLY 14.3.1.4. The following procedures must be executed in the indicated sequence—

1. Place the canister assembly in the left cradle on the backplate. The two outlets are now at the upper end of the backplate. Rotate the canister so that the outlets are toward the backplate and about equidistant from it (rather than rotated away from it). Thread the retaining clamp through the cradle and fasten it securely around the canister. The thumbscrew of the retaining clamp should be positioned between the canister and the cylinder so that it does not interfere with the cover.

2. Place the cylinder assembly in the right-hand cradle. The reserve pull rod should fall between the canister and the cylinder, and the cylinder valve should extend to the right. Now attach the retaining clamp, again positioning its thumbscrew in the central space.

3. Attach the vest assembly to the backplate assembly by aligning the three vest hinge loops with the two corresponding loops on the backplate and inserting and closing the shoulder pin.

4. Attach the mouthpiece assembly to the breathing bags using the clamps provided. Be sure to attach the inhalation hose to the right bag and the exhalation hose to the left bag. In the diving (DIVE) position, the lever on the mouthpiece is pointing downward.

5. Connect the canister to the breathing bags by inserting the male hose connections into the proper receptacles on the canister; the left bag hose to the left-hand inlet, and the right bag hose to the right-hand outlet. Do not twist or kink the hoses.

6. Attach the backplate cover to the backplate by placing the two ears of the cover in the receiving slots at the lower edge of the backplate. Before securing the retaining latch at the top, be sure the reserve arm

is in the START DIVE position, and that the reserve rod extends through the slot provided for it in the bottom of the cover. Close the cover and secure the retaining latch.

7. After the weights are inserted (as required), attach the waist valve to the right-hand weight pocket using the commonsense fasteners. The metering valve should be at the lower edge. Connect the breathing bag supply hose and waist valve inlet hose to the waist valve by placing the quick-connect fittings down over their counterparts on the waist valve. When the fitting is snapped in place, rotate the locking ring clockwise to prevent the fitting from inadvertently becoming disengaged.

PREDIVE EQUIPMENT PREPARATION 14.4

To prepare the oxygen SCUBA for use, the oxygen cylinder must be charged, the CO₂ absorption canister filled, the inhalation and exhalation valves checked, and the entire apparatus leak tested.

Charging the Oxygen Cylinder 14.4.1 The oxygen cylinder must be filled with medically pure oxygen (FSN 9G683-290-4290) to a pressure of 2,000 psig. Observe the following safety rules for charging—

WARNING

1. Avoid all contact of oil or grease with high pressure fittings. Such material exposed to oxygen under high pressure may explode.
2. The oxygen cylinder should be treated with care.
3. Charge cylinders with the proper grade oxygen only.
4. Do not charge above 2,000 psig.
 - A. Remove the regulator from the cylinder valve and place the reserve arm in the RESERVE position.
 - B. Purge the high-pressure filling line of gas and particles by briefly opening the high-pressure oxygen source.
 - C. Connect the high-pressure oxygen source to the valve on the cylinder and fully open the cylinder valve.

D. Slowly open the valve of the high-pressure oxygen source, and fill the oxygen cylinder to the desired pressure, taking at least 5 minutes per 1,000 psig. The cylinder will become warm during filling. Allow the cylinder to cool, and finish charging if maximum pressure is desired.

NOTE

To insure maximum pressure, the cylinder should be cooled by immersing it in a bucket of water during charging.

E. Close the cylinder valve and the valve of the high-pressure oxygen source. Then bleed the charging line, and detach the filled cylinder.

F. Test the cylinder valve for complete closure.

G. Reattach the regulator to the cylinder valve.

Loading the Carbon Dioxide Absorption Canister

14.4.2 The carbon dioxide absorption canister must be filled with fresh USN approved carbon dioxide absorbent prior to every dive. It is carried in the Navy Stock System.

To load the carbon dioxide absorption canister—

A. Remove the canister from the backplate and detach the two quick-connect fittings of the hoses from the canister.

B. Detach the canister cover by loosening the cover-retaining thumbscrews simultaneously. Lift the cover off gently with the screen attached.

C. Wipe the canister free of absorbent dust if it is not already clean.

D. Fresh absorbent must be poured onto a screen of appropriate mesh size to allow broken particles of absorbent to be discarded. The screened absorbent must be then blown free of dust using oil-free air, nitrogen or oxygen.

E. Insert the canister charging funnel in the open end of the inside shell. Fill the inside shell with the screened absorbent. To insure proper packing of absorbent granules, gently tap the side of the canister with the hand as it is filled. The canister should be

filled to the bottom lip of the funnel or to within about ¼ inch from the top of the inside shell.

F. Hold the screen and cover assembly in place over the open end of the inside shell and blow sharply through the outlet quick-disconnect fitting several times to clean the canister of any remaining dust.

G. Replace the canister cover in its indexed position, making sure that the O-ring and its seat are clean (a small amount of Dow Corning No. 4 silicone lubricant is recommended for the O-ring), and that the cover flat-ring seal seats properly on the canister rim. Secure the retaining thumbscrews firmly.

H. Reattach the canister to the backplate in the correct position.

Checking The Inhalation and Exhalation Valves

14.4.3 To check the inhalation and exhalation valves, place the mouthpiece in the mouth with the lever in the DIVE (downward) position. Squeeze closed the inhalation (right-hand) hose and try to inhale through the mouthpiece. Next squeeze closed the exhalation (left-hand) hose and attempt to exhale through the mouthpiece. If it is possible to inhale with the inhalation hose closed or exhale with the exhalation hose closed, the check valves are improperly positioned or faulty. Do not use the apparatus until this condition has been corrected.

Checking the Apparatus for Oxygen Leakage

14.4.4. The entire apparatus, including the high-pressure and low-pressure oxygen delivery systems and the rebreathing system, should be tested for defective connections as follows—

A. Close the mouthpiece shutoff valve.

B. Open the cylinder valve and metering valve, then fill the breathing bags to a firm condition by depressing the bypass valve. Close the cylinder valve to stop gas flow through the waist valve. No excess gas pressure now exists in either the high- or low-pressure gas systems.

C. Immerse the entire apparatus in water and carefully search for sources of leakage in the rebreathing system.

D. Carefully search for leaking gas at the delivery connections, using soap suds, Leak-Tek, or a similar commercial product.

E. When finished, relieve the pressure in the breathing system by opening the mouthpiece valve.

PREDIVE EQUIPMENT CHECKLIST 14.5

The following minimum equipment is required to conduct oxygen SCUBA diving—

Closed-Circuit SCUBA	Swim Fins
Life Jacket	Knife
Depth Gage	Wristwatch
Facemask	

The following optional equipment may be required depending upon diving conditions and mission requirements—

Protective Clothing	Floats
Wrist Compass	Slate and Stylus
Signal Flares	Noseclip

PREDIVE APPARATUS INSPECTION 14.6

When the canister and cylinder are full and the unit has been checked for leaks, a final routine pre-dive inspection must be made before donning the apparatus—

1. Check all fittings and screws for tightness. Pay careful attention to the five quick-connect fittings.

WARNING

Check all five quick-connect fittings for complete closure. Be sure that the lock rings are tight, then tug on hoses to insure that they are securely locked.

2. Check the breathing bags for torn edges or worn spots that might rupture during use.

3. Insure that the breathing bag drain caps are tightly in place.

4. Make sure that the shoulder pin passes through all three loops on the vest, as well as both hinge loops on the backplate, and that it is closed.

5. Check the breathing hoses by stretching and inspecting for pinholes and possible deterioration of the neoprene (this is indicated by numerous small cracks on the exterior surface).

6. Check the mouthpiece valve assembly, as discussed in Section 14.4.3.

7. Close the metering valve and slowly open the cylinder valve handwheel all the way. Insure that the reserve arm is in the START DIVE (Up) position. The apparatus is now ready to don.

DONNING EQUIPMENT 14.7

Use the apparatus only after proper charging of the cylinder and canister, a thorough check for gas leakage, and a complete pre-dive inspection—

1. Place the apparatus over the shoulders with the front vest zipper open. Close the front zipper, and adjust the side harness straps securely.

2. Close the mouthpiece shutoff valve and inflate the breathing bags by depressing the bypass lever. Check the closed mouthpiece valve for tightness of seal by forcibly attempting to blow air through it.

3. Don the life jacket. Although the breathing bags of the oxygen SCUBA will provide a certain amount of buoyancy under normal conditions, an inflatable lifejacket is an essential piece of safety equipment. Partial flooding of the CO₂-removal canister or the onset of oxygen toxicity may cause a stricken diver to lose his mouthpiece (without closing the mouthpiece valve) and flood the apparatus. The lifejacket provides immediate buoyancy assistance through actuation by the diver or his swim buddy.

4. Review the mission and dive profile with the Diving Supervisor.

5. Don swim fins, facemask, and noseclip, if required. (Many divers experienced with air SCUBA have a tendency to exhale a portion of each breath through the nose into the facemask to keep it clear. This action must be avoided when diving with oxygen SCUBA, since it would allow oxygen to escape from the circuitry. A noseclip is often helpful in eliminating the habit.) Insert the mouthpiece in the mouth, and open it to connect with the rebreathing system.

6. Purge the system as follows—

WARNING

It is necessary to purge the rebreathing system; a procedure that must be done with extreme care. If excess air is not removed from the breathing bags and from the lungs before oxygen breathing starts, a considerable amount of nitrogen will remain in the respiratory system. This may be sufficient to provide a breathable volume of nitrogen after all the oxygen has been used. Because the body requirements for oxygen will not be satisfied, unconsciousness or death may occur from lack of oxygen (hypoxia).

A. Empty the breathing system. Do this by closing the metering valve, opening the mouthpiece valve, inhaling, closing the mouthpiece valve, and then exhaling to the atmosphere. Repeat this operation until the bags are sucked empty and are completely collapsed.

B. With the bags collapsed, the mouthpiece valve in the closed position, and the cylinder valve open, add oxygen to the rebreathing system using the bypass valve until it is approximately three-quarters full.

C. Now exhale to the atmosphere, insert the mouthpiece, and open the mouthpiece valve. Purge the lungs by inhaling from the mouthpiece, closing the mouthpiece valve, removing it, and then exhaling to the atmosphere. Add oxygen as required by operating the bypass valve. Breathe down the bags three times, being careful not to allow any atmosphere to enter the breathing apparatus or lungs. If this occurs, steps (A) through (C) must be repeated.

D. If the mouthpiece (or faceplate) is removed before entering the water, the breathing bags and diver's lungs must be purged again.

E. Adjust the oxygen level in the bags, using the bypass valve, and set the metering valve to the appropriate setting. To start a dive, 0.9 liter is usually adequate.



A After dressing (trunks or wet suit) the diver puts on the life vest buckling it at his waist, letting it hang in front of him.



B The tender then assists the diver into the vest, positioning the SCUBA on the diver's back.



C The vest is zipped.

Figure 14-15 Pre-dive dressing procedures.

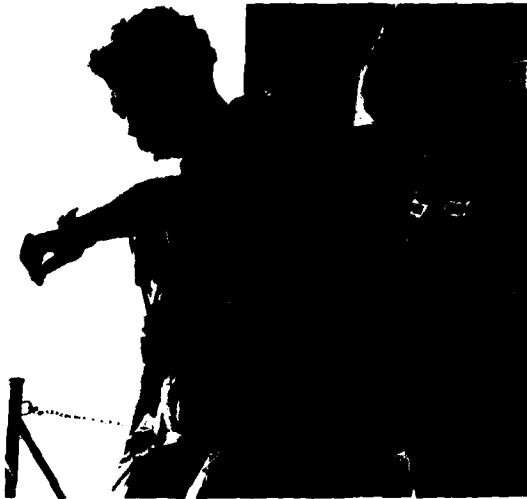

D The tender cinches the vest adjustment straps securing the SCUBA to the diver.



F The mouthpiece is brought over the diver's head into its proper position.



E The life vest is brought up over the diver's head—positioned and adjusted.



G With the addition of face mask, swim fins and other equipment, the diver will be ready for the pre-dive checkout of his equipment.

SURFACE CHECKOUT 14.8

When the apparatus is properly donned and functioning, obtain approval from the Diving Supervisor to enter the water.

1. Check the metering valve setting.
2. Enter the water and make, or have a swim buddy make, a final check for leaks. Do the same for the swim buddy.
3. Check the bypass valve.
4. Check the time and take surface bearings.

UNDERWATER PROCEDURES 14.9

Descend to the directed depth using the bypass valve as necessary to maintain an adequate supply of oxygen in the breathing bags. During descent, the decrease in the bag volume due to compression by the increasing water pressure may result in negative buoyancy and increasingly rapid descent. The preset flow should be supplemented on descent by intermittent use of the bypass valve to adequately maintain the volume of the bags for breathing and for control of the rate of descent. The diver must not descend more rapidly than the breathing volume can be restored. To do so will result in squeeze of the bags and lungs, as well as of structures within the faceplate.

NOTE

The cylinder constant reserve valve is set for 500 ± 50 psig, but it starts restricting the gas flow at approximately 800 psig. The flow rate between 800 and 500 psig is adequate to maintain a constant bag level, but is not enough to give full flow through the bypass valve. If it is necessary to use the bypass valve and the flow appears to be inadequate, it is an indication that the cylinder pressure is somewhere between 800 and 500 psig. For full flow, the constant reserve valve rod must be pulled to place the valve in its reserve position.

Do not exceed the diving limits for pure oxygen as established in Section 14.1 or the planned dive profile. While underwater the diver must be constantly alert for the symptoms of oxygen toxicity as discussed

in Section 9.3.2 (V-E-N-T-I-D: Vision-Ears-Nausea-Twitching-Irritability-Dizziness). Surface immediately if any symptoms are felt.

If the apparatus is accidentally flooded or if water leakage occurs, carbon dioxide poisoning will result. If the presence of seawater is suspected in the absorbent canister, surface immediately using the additional buoyance of the lifejacket if required.

The oxygen rebreather is not equipped with an exhaust valve. During ascent observe the following warning—

WARNING

Because the apparatus has no exhaust valve, excess gas must be expelled through the mouth (or nose) during ascent to prevent lung damage and embolism.

POSTDIVE PROCEDURES 14.10

Careful preventive maintenance of the diving equipment extends its useful life and enhances diver safety. Wash, dry, and carefully stow all accessory equipment. Maintain the oxygen rebreather as indicated below.

Routine Cleaning 14.10.1

A. Salt removal—As soon as practicable after each day's use in salt water, thoroughly rinse the outside of the apparatus with fresh water. This is best done by hosing or by dipping the entire assembled apparatus into a large can of fresh water, first making sure that the mouthpiece shutoff valve and bag drains are closed and all gas delivery fittings are connected. This procedure will wash salt off the fittings.

B. Alkali removal—If the breathing system has been flooded during use to the extent of wetting the carbon dioxide absorbent, wash the inside of the entire respiratory system (breathing bags, canister, breathing hoses, and mouthpiece assembly) to remove alkali. Do not wash the gas delivery system if it is clean. Instead, disconnect the two hoses from the waist valve so moisture will not reach it. If possible, dry all components before reuse.

If flooding causes entrance of water and alkali into the gas delivery system, corrosion and crystallization may in time obstruct the passages in the waist valve.

The waist valve should be separated from the regulator and breathing bag, and flushed thoroughly with fresh water. The waist valve and connecting hoses should be dried before reassembly. The regulator can usually be cleared of dampness by discharging oxygen through it for one or two minutes at low pressure.

C. Canister cleaning—After every dive dump the used absorbent and wipe the inside of the canister clean of absorbent dust. Prior to dumping the absorbent, however, check it for dampness. Excessively damp absorbent is probably a sign that one or more of the valves or fittings in the circuit is leaking. Should this be evident, determine the location of the leak and make the necessary repairs. A common cause of leakage in the canister is a faulty relief valve.

Periodically, the inside shell should be removed from the outside shell for thorough cleaning and inspection. To remove the inside shell remove the cover, detach the outlet quick-connect fitting and O-ring from the canister, and slide the shell out. After it has been cleaned, reinsert the inside shell into its outside shell, making sure it is properly aligned, and press firmly into place. There are two corresponding markings on the outside shell and the canister cover for easy alignment.

Remove the low-pressure relief valve from the top of the canister and inspect the sintered filter in its base; remove and clean if required.

Lubrication 14.10.2 No lubrication of metal parts of the apparatus should be necessary. If corrosion occurs on threaded areas of the fittings, clean them with a fine brass wire brush.

Before reassembly, take care to blow corrosion dust off with oil-free compressed air or nitrogen.

On the O-rings which seal the fiberglass components it is advisable to use a small amount of silicone lubricant (such as Dow Corning No. 4 compound). Use of the lubricant significantly reduces the possibility of water leakage into the canister.

General Inspection 14.10.3 A general inspection should be carried out routinely in the following manner—

- A. Check all fittings and screws for tightness.
- B. Check the breathing bags and vest assembly for torn edges and punctures.
- C. Check the breathing tubes by stretching and inspecting for pinholes and possible deterioration of the neoprene (as revealed by a multiplicity of small cracks on the exterior-surface).
- D. Check the breathing bags and mouthpiece hoses for water, and drain if necessary.
- E. Close the cylinder valve handwheel.

TROUBLESHOOTING 14.11

Improper function of the apparatus will rarely be caused by mechanical failure of a part or wear of components, because the equipment contains few moving parts. The most common cause of malfunction will be leakage of oxygen out of the apparatus or water into it, caused by improperly maintained connections. Malfunction can be practically eliminated by careful routine inspection of the apparatus.

Loss of Gas Apparatus 14.11.1

A. Check high-pressure system—Locate the source of the leak by submergence, or painting with soap solution or Leak-Tek. Repair individual leaks as follows—

1. **Reserve-valve safety disk**—Empty the cylinder and replace the disk.
2. **Cylinder valve**—Empty the cylinder, remove the valve handwheel, and tighten the gland nut. If necessary, remove the gland nut and replace the O-ring.
3. **Reserve arm**—Empty the cylinder, remove the reserve valve arm, and tighten the gland nut. If necessary, remove the gland nut and replace the O-ring.
4. **Threads between cylinder and cylinder valve**—Remove the valve, clean the threads on both valve and cylinder, and replace. Use a small amount of oxygen service, thread-sealing compound of a type approved by the Naval Sea Systems Command. Never use oil, grease, or paint where it can come in contact with high-pressure oxygen.

5. Connection between cylinder valve and regulator yoke—This is the most common source of high-pressure leaks and usually requires only tightening of the yoke wingnut to stop the leak. If the O-ring is damaged, replace it.

B. Check low-pressure system—First check the high-pressure system, as in 14.11.1A. Locate the source of the low-pressure leak by submerging or painting system with soap solution.

1. Regulator body low-pressure fitting—Remove, clean the threads, and replace using a thread-sealing compound of a type approved by the Naval Sea Systems Command.

2. Regulator relief valve—Replace sealing O-ring.

3. Regulator inlet hose—Replace leaking hose or damaged pressure fitting.

4. Waist valve—Remove and clean or replace leaky fittings. Replace defective quick-connect fittings. Replace the packing in the metering valve. Replace damaged O-rings.

C. Check rebreathing system—Close the mouthpiece shutoff valve, and inflate the breathing bags. Locate the source of the leak by submerging.

1. Canister cover—Correct for overfilling of canister by removing some of the absorbent. Reseat or clean the canister cover O-ring and seal if displaced or dirty. Replace canister cover if damaged. The most likely cause of leakage is a dirty canister cover O-ring.

2. Breathing hoses and connections—Tighten loose connections and replace worn hoses.

3. Mouthpiece shutoff valve—Replace gaskets or valve clamps, as needed.

Entrance of Water Into Apparatus 14.11.2

Neither the high-pressure nor the low-pressure gas delivery systems, even if leaking gas, should allow water to enter the apparatus during use. Water leakage into the apparatus is therefore most probably due to a defect in the rebreathing system. To detect the source of water leakage, proceed as in checking for and correcting gas leakage from the breathing system.

Regulator Failure 14.11.3 If the regulator malfunctions, completely disassemble it by removing the relief valve, yoke, bonnet piston, spring, snapping, and filter. Clean all parts, except the relief valve, with a cleaning solvent approved by Naval Sea Systems Command for cleaning oxygen equipment. Blow through all passages and the filter, using approved oxygen. Inspect all parts for wear and replace as required. Allow all parts to dry and reassemble, installing new O-rings if required. Apply a small amount of oxygen lubricant approved by Naval Sea Systems Command to the O-rings.

Reassemble the regulator to the cylinder and check the regulated output (80 ± 8 psig).

If the relief valve fails to actuate or reseal within a range of 300 ± 50 psig, remove from the regulator, disassemble, clean with an oxygen cleaning agent approved by Naval Sea Systems Command and reassemble.

SHIPMENT AND STORAGE 14.12

In routine shipment, the detachable components of the apparatus should be removed, wrapped in dustless, shock-absorbent packing materials, and carefully supported with a rigid packing container. The carbon dioxide absorption canister and the gas cylinder should be emptied prior to packing for storage or shipment.

The apparatus should not be stored near fire nor at temperatures above 110° F, nor should it be exposed to prolonged periods to the direct rays of the summer or tropical sun. Heating of the high-pressure cylinder can cause an increase in cylinder pressure, with rupture of the safety disk and violent discharge of oxygen.

Between periods of use, care should be taken to avoid damage to the apparatus from continuous distortion of its flexible components, or from pressure of heavy parts upon its fabric and rubber components.

Contamination of the apparatus with oils, greases, paints, etc., should be carefully avoided. Provision should be made for drying components after use to deter rot and corrosion.

CHAPTER FIFTEEN

MIXED-GAS SURFACE-SUPPLIED DECOMPRESSION

The following three chapters include mixed-gas decompression tables for: Helium-Oxygen Surface-Supplied Decompression (Chapter 15), Mixed-Gas Scuba Decompression (Chapter 16), and Mixed-Gas Saturation Decompression (Chapter 17).

GENERAL INSTRUCTIONS 15.1

Section 15.1 is equally applicable to Chapters 15, 16 & 17.

Mixed-gas diving is more complex than air diving but permits a choice of *underwater breathing apparatus*, inert gas, dive procedures, oxygen levels, and decompression procedures optimal for the operational requirement. The selection of appropriate equipment and procedures allows emphasis on one or more of the following operational advantages: greater depth, longer duration, reduced decompression obligation, avoidance of nitrogen narcosis, and avoidance of oxygen toxicity.

As in air diving operations, all instructions for mixed-gas decompression must be rigidly followed to maximize diver safety. Alteration of established mixed-gas decompression procedures and tables shall be made only under the direction of a qualified diving medical officer in emergency situations.

Oxygen Concentration 15.1.1 As a consequence of greater depth, longer exposure times and the capability to vary the amount of oxygen in the diver's breathing gas, the problem of oxygen toxicity is more pronounced in mixed-gas diving than in air diving. Operationally the diver and surface crew must be constantly alert for developing symptoms of oxygen toxicity as discussed in Section 9.3.2.

Particular care must be taken in the mixing of gases to insure the proper oxygen composition for the breathing apparatus to be used and the depth and duration of the planned dive. The oxygen partial pressure limits accompanying each table establish the allowable exposure criteria for normal and exceptional operating conditions. It is essential that dives be conducted within the specified limits. It should be noted, however, that these values are for divers **at work** and are routinely exceeded during certain decompression procedures when the divers are **at rest**.

Selection of Schedules 15.1.2 Selection of the appropriate non-saturation decompression schedule should take into account not only the depth and bottom time of the dive but also the condition of the diver. If the bottom activity has been extremely arduous or the diver has been particularly cold during the dive, use the next longer bottom time schedule for that depth. If the actual dive depth or computed partial pressure is within a few feet of the selected schedule and surface conditions interfere with accurate depth control during decompression, use the next deeper schedule for decompression.

Exceptional Exposures 15.1.3 Normal and exceptional exposure schedules are combined in the "SCUBA" and "Surface-Supplied" chapters. Exceptional exposure schedules should never be used except in cases of extreme operational necessity or in the case of a fouled diver who has exceeded his normal bottom time. Because of the limited assurance of successful decompression using these schedules, their use for operational dives shall be directed only by the Commanding Officer of the diving facility involved when uniquely operationally warranted.

Repetitive Dives 15.1.4 Non-saturation, repetitive mixed-gas diving may only be conducted using SCUBA. Procedures for determining the decompression schedule to be used for a repetitive SCUBA dive are similar to those for air diving and will be found in Chapter 16. Repetitive dives using surface-supplied mixed gas are not permitted; a minimum 12-hour surface interval is required between surface-supplied dives. Saturation diving excursion tables and procedures are discussed in Chapter 17.

Decompression Sickness 15.1.5 Decompression sickness occurring in non-saturation mixed-gas diving (both SCUBA and Surface-Supplied) is treated in the same manner as in air diving. Required procedures will be found in Volume 1, Chapter Eight of the Diving Manual. Use of the oxygen treatment tables is the preferred method. Decompression sickness which occurs as a result of a saturation exposure is not treated using the conventional recompression procedures. Special treatment procedures have been developed for saturation diving and are discussed in Chapter 17.

HELIUM-OXYGEN SURFACE-SUPPLIED DECOMPRESSION TABLES 15.2

The Helium-Oxygen Surface-Supplied Decompression Tables, also referred to as the "partial pressure decompression tables," are used for deep diving with recirculating hard hat gear and surface-supplied flow-through or demand-type breathing equipment. These tables permit the use of He-O₂ mixtures with a wide range of oxygen concentrations.

Oxygen Limits 15.2.1 The normal minimum oxygen concentration in the supply gas should be 16%. This is the lowest level which will permit breathing on the surface without the development of hypoxia. The maximum allowable oxygen concentration is governed by the hazard of oxygen toxicity and is dependent upon the depth and bottom time for a given dive. The oxygen partial pressure and exposure time that will be experienced at depth with a given gas mixture must not exceed the limits of the following tables—

OXYGEN PARTIAL PRESSURE LIMITS TABLE NORMAL EXPOSURES

Exposure Time (min.)	Maximum Oxygen Partial Pressure (atmospheres)
30	1.6
40	1.5
50	1.4
60	1.3
80	1.2
120	1.1
240	1.0

EXCEPTIONAL EXPOSURES

Exposure Time (min.)	Maximum Oxygen Partial Pressure (atmospheres)
30	2.0
40	1.9
60	1.8
80	1.7
100	1.6
120	1.5
180	1.4
240	1.3

The following three equations are useful in computing oxygen concentrations under various conditions—

$$\text{Maximum depth for a particular oxygen mixture} = \frac{\text{limiting oxygen partial pressure in atmos.} \times 33}{\text{oxygen percentage decimal fraction}} - 33 \quad \text{equation 15.1}$$

$$\text{Maximum oxygen percentage for a particular depth} = \frac{\text{limiting oxygen partial pressure in atmos.} \times 33}{\text{depth} + 33} \times 100 \quad \text{equation 15.2}$$

$$\text{Effective oxygen partial pressure in atmospheres} = \frac{\text{depth} + 33}{33} \times \text{oxygen percent decimal fraction} \quad \text{equation 15.3}$$

Inert Gas Partial Pressure 15.2.2 Using the partial pressure of the inert gas instead of the actual depth of dive is the main difference between the surface-supplied air and helium-oxygen decompression methods. Since decompression from any given depth and bottom time exposure is governed by the uptake of inert gas by the body, the partial pressure of the inert component in the breathing mixture establishes the decompression profile. Based upon this principle, a series of tables were developed for surface-supplied helium-oxygen diving. Each table provides decompression schedules for a given partial pressure of inert gas (expressed in feet of seawater) in the breathing mixture at depth.

Selection of the correct He-O₂ decompression table may be accomplished by either of two methods—use of the He-O₂ Partial Pressure Table or by direct computation. Direct computation is the most accurate and the most commonly used procedure. Since the partial pressure of the inert component is equal to the absolute depth minus the partial pressure of oxygen, any reduction in oxygen percentage increases the inert gas partial pressure. When the recirculating mixed-gas helmet is used, a 2% reduction in oxygen content in the breathing mixture occurs due to metabolic consumption, and a suitable correction factor must be used in the equation. This correction factor is an inte-

HELIUM-OXYGEN PARTIAL PRESSURE, DEPTH AND OXYGEN PERCENT TABLE

Depth (feet)	Oxygen percent												
	15	16	17	19	21	23	25	30	35	40	45	50	55
40	64	63	63	61	60	58	57	[*]	[*]	[*]	[*]	[*]	[*]
50	73	72	71	69	68	66	64	60	56	[*]	[*]	[*]	[*]
60	81	80	80	78	76	74	72	67	63	58	54	[*]	[*]
70	90	89	88	86	84	82	80	75	70	64	59	54	[*]
80	99	98	97	94	92	90	88	82	76	71	65	59	54
90	108	106	105	103	100	98	95	89	83	77	71	64	
100	116	115	114	111	108	106	103	96	90	83	76		
110	125	123	122	119	116	113	111	103	96	89	82		
120	134	132	131	127	124	121	118	111	103	95			
130	142	141	139	136	133	129	126	118	110	102			
140	151	149	148	144	141	137	134	125	116				
150	160	158	156	152	149	145	141	132	123				
160	168	166	165	161	157	155	149	139					
170	177	175	173	169	165	161	157	147					
180	186	184	182	177	173	169	165	154					
190	195	192	190	186	181	177	172						
200	203	201	199	194	189	185	180						
210	212	209	207	202	197	192	188						
220	221	218	216	210	205	200	195						
230	229	227	224	219	214	203	203						
240	238	235	233	227	222	216							
250	247	244	241	235	230	224							
260	255	252	250	244	238								
270	264	261	258	252	246								
280	273	270	267	260	254								
290	282	278	275	269									
300	290	287	284	277									
310	299	295	292	285									
320	308	304	301										
330	316	313	309										
340	325	321	318										
350	334	330	326										
360	342	338											
370	351	347											
380	360	356											

Note: Use exact or next greater depth.
Use exact or next lesser oxygen percent.

Numbers in red indicate exposures which exceed the limit for a 30 minute exposure at 1.6 atmospheres PO₂.

*No-decompression

gral part of the He-O₂ Partial Pressures Depth and Oxygen Percent Table. If nonrecirculating breathing apparatus, e.g., MK 1 Mask, is used, no correction factor is employed. The procedures are as follows:

Use of HE-O₂ Partial Pressures Table 15.2.3

- A. Enter the He-O₂ Partial Pressures Table along the left margin using the exact or next greater depth.
- B. Select the oxygen percent column with the exact or next lesser oxygen percentage in the mix.
- C. At the intersection read the exact or next greater partial pressure table to be used.

Computation of Correct Table 15.2.4

Formula— $PP = (D + 33) \times [1.00 - (O_2 - 0.02)]$

Where— PP = partial pressure in feet of all other gases except oxygen (table designation = partial pressure)
 D = depth of dive in feet of seawater
 O₂ = decimal equivalent of oxygen percentage
 0.02 = an assumed loss of 2% O₂ in helmet

EXAMPLE—

PROBLEM—Determine the proper decompression schedule to dive with a mixed-gas deep-sea rig to 290 ft. with an 84% He-16% O₂ mixture for 12 minutes bottom time.

SOLUTION—

- 1a. Using He-O₂ partial pressure, depth and oxygen percent table

$$D = 290$$

$$PP = 278$$

$$\text{Use } PP = 280$$

or

- 1b. Computation

$$PP = (290 + 33) \times [1.00 - (0.16 - 0.02)]$$

$$PP = 323 \times (1.00 - 0.14)$$

$$PP = 323 \times 0.86$$

$$PP = 277.78$$

$$\text{Use } PP = 280$$

2. Conduct the dive using the He-O₂ Decompression Table with a Partial Pressure of 280, and the 20 minute schedule.

DECOMPRESSION PROCEDURE 15.3

Both in-water and surface decompression may be performed using the same Helium-Oxygen Surface-Supplied Decompression Tables by varying the operating procedure. Oxygen breathing (with the diver at rest) is used in both procedures.

Operating Procedures for In-water Decompression 15.3.1

- A. Select the appropriate partial pressure table as previously discussed.

- B. The rate of ascent from the bottom to the first stop is found as follows—

$$\text{Rate of Ascent To First Stop} = \frac{\text{Bottom Depth} - \text{Depth of First Stop}}{\text{Time to First Stop}}$$

- C. Remain at the first stop for the number of minutes indicated.

- D. The rate of ascent between stops should be 60 ft./min. Include the time of ascent in the subsequent stop.

- E. The use of these tables in in-water decompression requires a shift to oxygen at the 50 foot (if included in the schedule) or 40 foot decompression stops. Upon arrival at the 50 foot stop (40 foot stop if no 50 foot stop), ventilate the diver with 25 actual cubic feet of oxygen then have him circulate for the remaining time. Three (3) minutes are allowed for ascent from the previous stop and ventilation. These 3 minutes are included in the 50 foot or 40 foot stop time.*

- F. Surface the diver at a rate of 40 feet per minute from the 40 foot stop during the last minute of decompression time.

EXAMPLE—

PROBLEM—Using the previous example of a dive to 290 feet for 12 minutes with an 84% helium-16% oxygen mixture, develop the dive profile. (Figure 15-1)

SOLUTION—A dive chart is a valuable tool for planning every phase of a dive (Figure 15-2). Information

*If the travel time to the 50 (or 40) foot stop plus the time to ventilate with 25 actual cubic feet of oxygen exceeds 3 minutes, the difference must be added to the remaining 50 (or 40) foot stop time.

readily available includes—

- rate of descent
- rate of ascent to first stop
- rate of ascent between stops
- stop times (including time of ascent)
- depth of dive
- stop depth
- bottom time
- total ascent time
- total dive time
- surface interval (when applicable)
- He-O₂ stops
- oxygen stops
- emergency He-O₂
- emergency Air stops

The dive profile for in-water decompression of the example dive is shown below.

OPERATING PROCEDURE FOR SURFACE DECOMPRESSION 15.4

It is routine procedure to employ the surface decompression technique with oxygen breathing in helium-oxygen surface-supplied diving as an alternate to

complete in-water decompression. This technique improves the comfort and safety of the diver by reducing his time underwater and provides simplified handling of oxygen toxicity problems. A recompression chamber equipped for oxygen breathing is required. Selection of the correct schedule using the Helium-Oxygen Surface-Supplied Decompression Table and initial in-water decompression are the same as the instructions for in-water decompression. The following changes are made in the final stages of decompression—

- A.** For Schedules in Which the First Stop is 40-Feet—
1. Upon reaching the 40 foot stop, ventilate with 25 actual cubic feet of oxygen.
 2. Remain at 40 feet on O₂ for a total of 10 minutes.
 - *3. Surface in 1 minute.
 - *4. Repressurize to 40 feet in the recompression chamber, breathing O₂ from the surface.
 5. Breathe O₂ by mask for the full time of the 40 foot stop. At the chamber stop during surface decompression oxygen breathing may be interrupted at 30 minute intervals with a 5 minute

*Maximum allowable combined time for these steps is 5 minutes.

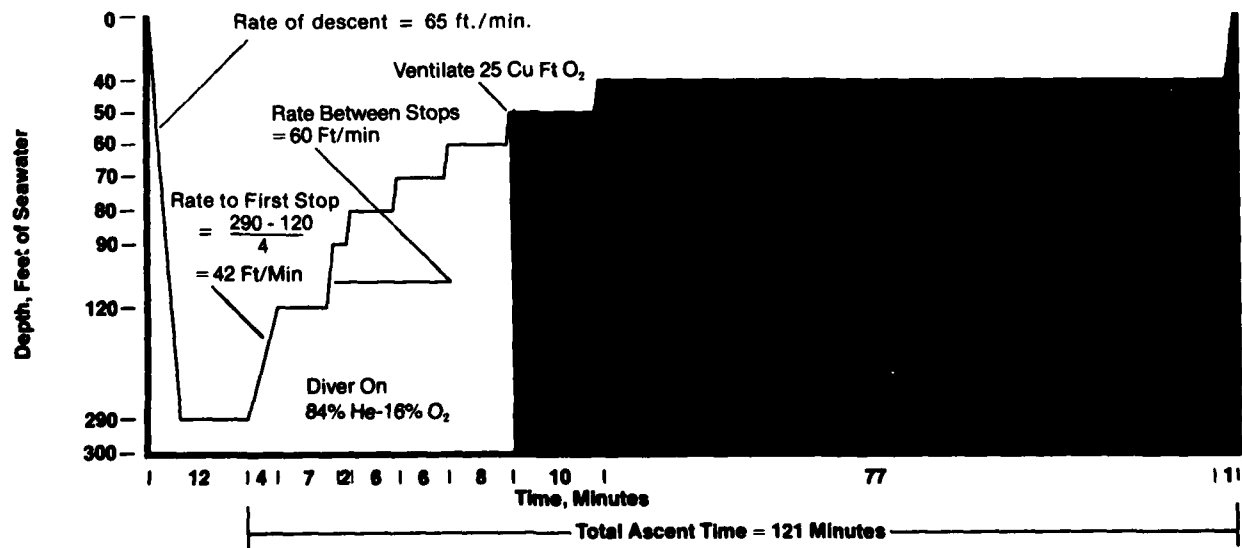

Figure 15-1 Dive profile for dive to 290 feet, 12 minutes, 84% He-16% O₂, in-water decompression

DIVING CHART - HE-O ₂ NAVSIPS 9940/11 (6-68) U.S. 0105-642-3200									
NAME		DATE	TABLE NO.	DEPTH (FEET)	MAXIMUM D.	DEPTH (FEET)	TIME TO SURFACE	TIME TO SURFACE	TOTAL TIME
JOE DIVER		BMC	280	20	16	1.56	297		
LEFT STOP		0000	0005	0012	04	12	129.05		
DEPTH IN FEET		290	16	2:01	2:13	277.78			
DEPTH IN FEET	EMERG. ASCENT	DEPTH OF STOPS FT.	DECOMPRESSION TIME AT STOP	EMERG. HE O ₂	PRESSURE IN PSY	TIME	RATE OF ASCENT IN FPM		
		200			89				
		190			85				
		180			80				
		170			75				
		160			72				
		150			67				
		140	4		62				
		130	14		58				
		120	16		54	0016 0023			
		110	16		49				
		100	18		44.5				
		90	19		40	0025			
		80	22		36	0031			
		70	24		32	0037			
		60	26		27	0045			
		50	30	SHIFT O ₂ 10	26	22	0055		
		40	35	78-1 ⑦	30	18	0212		
		30	42		35	13			
		20	52	32	42	9			
		10	68		58	4.5			
REACHED SURFACE		DIVER'S CONDITION AND REMARKS							
0213		NORMAL DIVE, DIVER OK.							

Figure 15-2 Diving Chart—HE-O₂ Standard Decompression

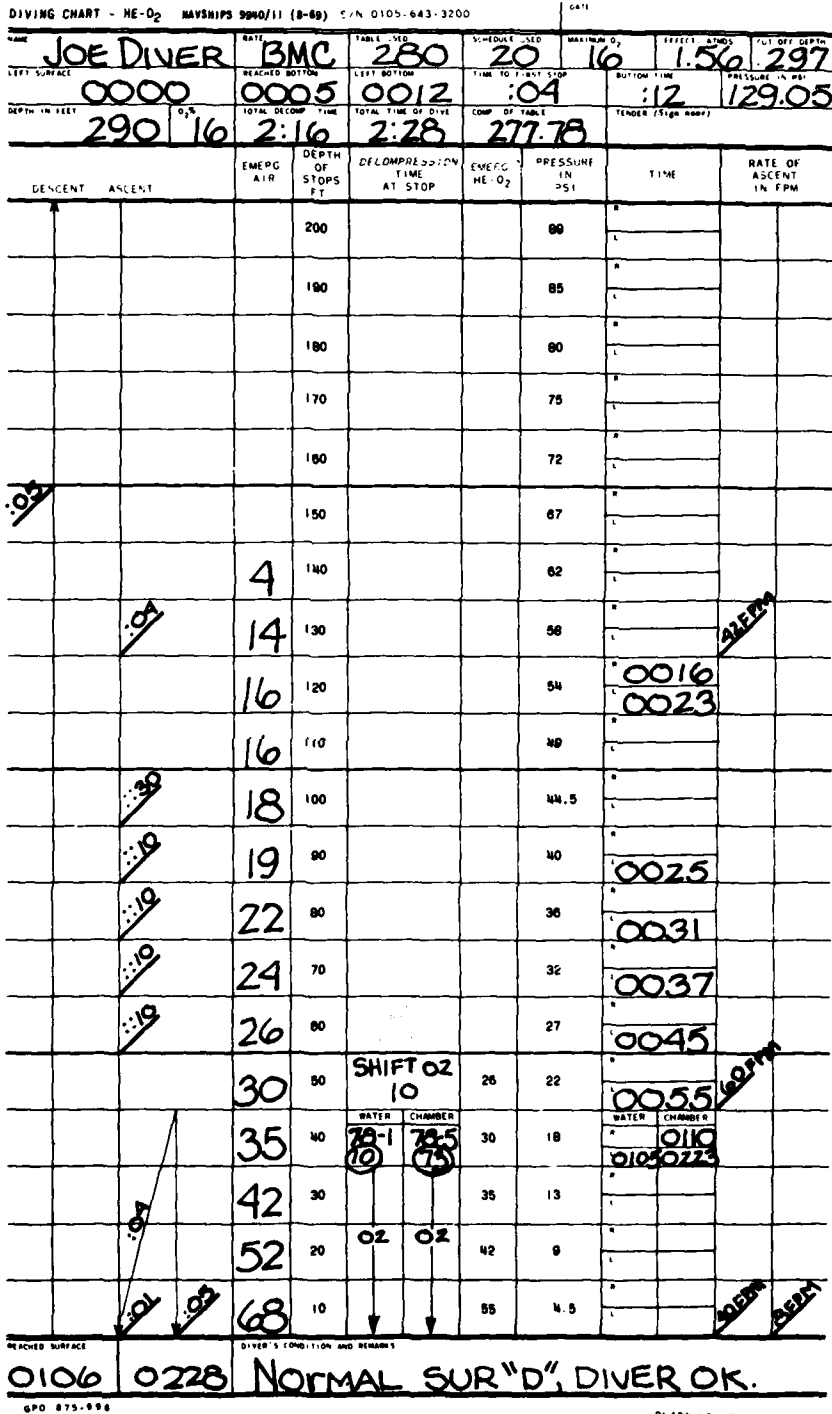

Figure 15-3 Diving Chart—HE-O₂ Surface Decompression.

air break. Consider time on air as dead time, and not a part of O₂ decompression. If interval falls on time to travel, commence traveling to the surface at a rate of 8 feet per minute while breathing oxygen.

6. During the last 5 minutes of decompression time, surface at a rate of 8 feet per minute while continuing to breathe oxygen.
7. Surface decompression can be used at anytime after the required time at 40 feet is met.

B. For Schedules in Which the First Stop is Deeper than 40 Feet—

1. Upon reaching the 50 foot stop, ventilate with 25 actual cubic feet of oxygen.
2. Circulate on O₂ for the time remaining of the 50 foot stop.
3. Ascend to the 40 foot stop and remain on oxygen for a length of time equal to that of the 50 foot stop time.
- *4. Surface in 1 minute.
- *5. Repressurize to 40 feet in the recompression chamber, breathing O₂ from the surface.
6. Breathe O₂ by mask for the full time of the 40 foot stop.

*Maximum allowable combined time for these steps is 5 minutes.

7. During the last 5 minutes of decompression time, surface at a rate of 8 feet per minute while continuing to breathe oxygen.

8. Surface decompression can be used at anytime after the requirement at 40 feet is met.

EXAMPLE—Using the previous example of a dive to 290 ft. with an 84% He-16% O₂ mix for 12 minutes bottom time, conduct a dive employing surface decompression using the He-O₂ decompression table with a partial pressure of 280 and the 20 minute schedule. The dive profile and chart are shown in Figures 15-3 and 15-4.

NOTE

Repetitive diving is not allowed when diving surface supplied He-O₂. The diver must have a surface interval of at least 12 hours after each He-O₂ dive.

NOTE

Exceptional Exposures (schedules printed in red) should only be used in cases of

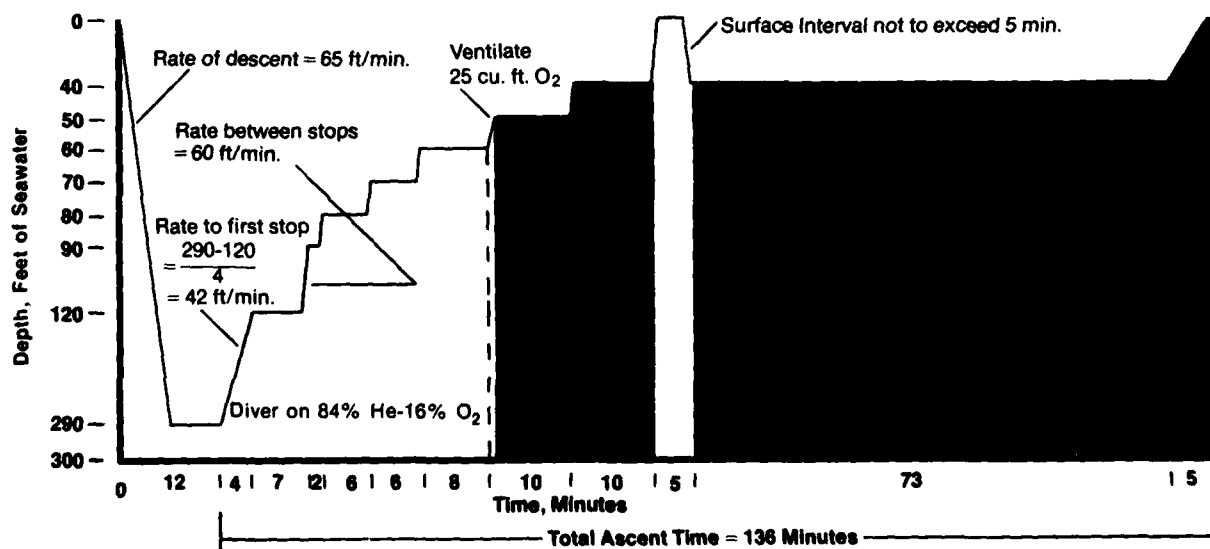

Figure 15-4 Dive profile for dive to 290 feet, 12 minutes, 84% He-16% O₂, surface decompression

extreme operational necessity or in the case of a fouled diver who has exceeded the normal maximum bottom time. Use of these schedules for operational dives shall be directed only by the Commanding Officer of the diving activity involved, and he shall assume the responsibility for any mishap which might occur because of their use. The only exception to the above limitations is that these schedules may be used with discretion at the Naval School, Diving and Salvage, during certain phases of diver training.

HE-O₂ DIVING CHART 15.5

The He-O₂ diving chart, shown in Figure No. 15-5 should be used for assistance in conducting a helium-oxygen dive. The chart provides spaces for information required to determine the dive schedule and for the recording of information required for the dive record (OPNAV 9940/1). Place the stop times as determined from the He-O₂ Surface-Supplied Decompression Table in the column marked "Decompression Time At Stop." Place the stop times as determined from the Emergency Air Table in the "Emergency Air" column.

All information should be filled out on the chart (next page) to insure a complete record and the availability of an emergency table without further reference to the Diving Manual during the dive.

EMERGENCY DECOMPRESSION PROCEDURES 15.6

Two Emergency Decompression Tables are provided in this section. These tables give alternate decompression schedules for situations in which the planned decompression breathing media cannot be used.

A list of emergency procedures to be used under various operating situations is also included at the end of this section. These guidelines include provision for omitted decompression, loss of He-O₂ and O₂ supplies, development of oxygen toxicity while in the water and during surface decompression, and variation in rate of ascent.

Emergency Helium-Oxygen Table 15.6.1 The Emergency He-O₂ Table should be used only when oxygen cannot be given during decompression. This may result from a failure of the oxygen supply or oxygen toxicity symptoms threatening the diver. If it is known in advance that oxygen cannot be used during decompression, use the regular schedules up to the first oxygen stop and then shift to the Emergency He-O₂ Table.

The helium-oxygen mixture used must contain a minimum of 16 percent oxygen.

EMERGENCY HELIUM-OXYGEN DECOMPRESSION TABLE

Decompression Stop Depth (feet)	Decompression Stop Time (min)
40	30
60	42
20	

EXAMPLE—

PROBLEM—A diver is undergoing decompression on the 190/30 schedule of the He-O₂ Surface-Supplied Table. The oxygen supply has fouled at the 40 foot stop. What is the diver's remaining decompression obligation?

SOLUTION—The diver, according to the 190/30 schedule has already spent 7 minutes at 70 feet, 4 minutes at 60 feet and 10 minutes at 50 feet. Having lost oxygen, he must now complete the decompression breathing a He-O₂ mixture according to the Emergency He-O₂ Table. The rate of ascent between stops is 60 feet per minute.

DIVING CHART - He-O₂

NAVSHIPS 9940/11 (8-69) S/N 0105-643-3200

DIVING CHART - HE-O₂ NAVSHIPS 9940/11 (8-69) S/N 0105-643-3200 Date _____

NAME		DATE	TABLE USED	SCHEDULE USED	MAXIMUM O ₂	EFFECTIVE AMGS	TOTAL DEPTH	
LEFT SURFACE		REACHED BOTTOM	LEFT BOTTOM	TIME TO FIRST STOP	BOTTOM TIME	PRESSURE IN PSI		
DEPTH IN FEET	O ₂	TOTAL DECOMP TIME	TOTAL TIME ON DIVE	COMP. OF TABLE	TENDER / (Sign Here)			
DESCENT	ASCENT	EMERG AIR	DEPTH OF STOPS FT.	DECOMPRESSION TIME AT STOP	EMERG HE O ₂	PRESSURE IN PSI	TIME	RATE OF ASCENT IN FPM
			200			89		
			190			85		
			180			80		
			170			75		
			160			72		
			150			67		
			140			62		
			130			58		
			120			54		
			110			49		
			100			44.5		
			90			40		
			80			36		
			70			32		
			60			27		
			50			22		
			40	WATER / HARBOR	30	18	WATER / HARBOR	
			30		35	13		
			20		42	9		
			10		55	4.5		

REACHED SURFACE _____

OTHER CONDITIONS AND REMARKS _____

GPO 875-996

PLATE NO. 2125a

Figure 15-5

Procedure	Elapsed Decompression Time (Minutes)	(Prior to loss of oxygen)
1. Remain at the 40 foot stop a total of 30 minutes	25	
2. Ascend to 30 feet and remain there for 35 minutes	55	
3. Ascend to 20 feet and remain there for 42 minutes	90	
4. Ascend to 10 feet and remain there for 55 minutes	132	
5. Surface	187	

Emergency Air Table 15.6.2 This table is used in an emergency when neither oxygen nor helium-oxygen can be used during decompression.

When using this table, the rate of ascent to the first decompression stop should be the same as that listed

in the Helium-Oxygen Surface-Supplied Table, but it must never exceed 60 feet per minute. The rate of ascent on subsequent stops is not critical as long as full decompression is received at each stop.

Schedules are provided for loss of the helium-oxygen or oxygen supply anywhere between the surface and 400 feet. Select the schedule that is equal to or the next deeper depth than the depth of the dive. Immediately after the shift to air, have the diver ventilate to remove any CO₂ built up while he was without a flow of breathing gas. After ventilation is complete, the diver should remain on open circuit.

EXAMPLE—

PROBLEM—The helium-oxygen supply to a diver at 220 feet has been lost. His normal decompression would have been conducted using the 220 partial pressure table. What is his new decompression obligation?

SOLUTION—Switch the diver to air immediately and bring him to the first decompression stop. According to the 250 foot schedule of the Emergency Air Table, which is the next deeper schedule, this stop would be 110 feet.

EMERGENCY AIR DECOMPRESSION TABLE

Stops (feet)	Depth up to (feet) —						
	100	150	200	250	300	350	400
190							3
180							11
170							12
160						9	13
150						13	14
140					4	13	15
130					14	16	16
120					16	16	17
110				13	16	17	18
100				18	18	18	20
90			7	18	18	20	22
80			22	22	22	22	24
70			24	24	24	24	27
60		22	26	26	26	27	30
50		30	30	30	30	30	35
40	14	35	35	35	35	35	42
30	42	42	42	42	42	42	52
20	52	52	52	52	52	52	55
10	55	55	55	55	55	55	55

Procedure	Elapsed Decompression Time (Minutes)
1. Ascend from 220 feet to 110 feet at $\frac{220 - 110}{4} = 27$ feet per minute	4
2. Remain at 110 feet for 13 minutes	17
3. Ascend to 100 feet and remain for 18 minutes	35
4. Ascend to 90 feet and remain for 19 minutes	54
5. Ascend to 80 feet and remain for 22 minutes	76
6. Ascend to 70 feet and remain for 24 minutes	100
7. Ascend to 60 feet and remain for 26 minutes	126

8.	Ascend to 50 feet and remain for 30 minutes	156
9.	Ascend to 40 feet and remain for 35 minutes	191
10.	Ascend to 30 feet and remain for 42 minutes	233
11.	Ascend to 20 feet and remain for 52 minutes	285
12.	Ascend to 10 feet and remain for 68 minutes	353
13.	Surface	

RULES FOR He-O₂ SUPPLY & O₂ TOXICITY PROBLEMS DURING ASCENT 15.7

A. LOSS OF He-O₂ SUPPLY

Deeper Than 50 Feet

1. Shift to air, decompress in accordance with the Emergency Air Table. No surface decompression is to be used.

B. LOSS OF O₂ SUPPLY

Loss at 50-Foot Stop

1. Shift to He-O₂ (preferably) or air. Complete the stops in accordance with the Emergency He-O₂ (or Emergency Air Table). Surface decompression can be used after completion of the 30 foot stop. The time spent on O₂ counts towards decompression.

Loss at 40-Foot Stop

1. If the loss occurs before the diver is within 5 minutes of repeating his 50 foot stop time (Emergency Surface Decompression Limit), shift to He-O₂ (preferably) or air. Complete the stops in accordance with the Emergency He-O₂ Table or the Emergency Air Table. Surface decompression can be used after completion of the 30 foot stop. The time spent on O₂ counts towards decompression.
2. If the loss occurs when the diver is within 5 minutes of repeating his 50 foot stop time (at 40 feet), surface decompress the diver. Double the missed time of the required water stop for surface decompression and add this to the normal 40 foot chamber stop.

3. If the loss occurs after the diver has repeated his 50 foot stop time (at 40 feet), surface decompress him in the normal manner.

C. O₂ TOXICITY SYMPTOMS

Symptoms at 50-Foot Stop

1. Ascend to the 40 foot stop. Shift to He-O₂ (preferably) or air. Surface decompression can be used after completion of the 30 foot stop. Disregard the missed time at 50 feet.

Symptoms at 40-Foot Stop

1. Not Within Normal Surface Decompression or Emergency Surface Decompression Limits: Ascend to the 30 foot stop. Shift to He-O₂ (preferably) or air. Surface decompress after completion of the 30 foot stop. Disregard the missed time at 40 feet.
2. Within Emergency Surface Decompression Limits: Surface decompress the diver. Double the missed time of the required water stop for surface decompression and add it to the chamber stop.
3. Within Normal Surface Decompression Limits: Surface decompress the diver normally.
4. Symptoms During Chamber Stop: Remove the mask. Allow 15 minutes after the reaction has entirely subsided and resume decompression at the point of interruption. Time on air is not a part of the required decompression, but is considered dead time. If the diver cannot tolerate oxygen at all, or if there is a loss of oxygen to the chamber, complete decompression in accordance with the Emergency Air Table of the original dive. All chamber time at 40 feet is good time when the shift to air is made.

D. CONVULSION AT 40- or 50-FOOT STOPS

1. If symptoms proceed to convulsion in spite of the above measures, bring the diver to the surface at a moderate rate, immediately recompress him to 165 feet and decompress on Treatment Table 6A.

NOTE

The danger of causing gas embolism by bringing the diver up during a convulsion caused by oxygen decompression is outweighed by the dangers of failing to do

so. The diver may have stopped breathing due to an obstructed airway, and must be brought to the surface without delay. Since the possibility that gas embolism has occurred cannot be ruled out in these cases, the diver requires treatment for such.

OMITTED DECOMPRESSION IN EMERGENCIES 15.8

Certain emergencies may interrupt or prevent specified decompression. Blowup, exhausted gas supply, bodily injury and the like are among such emergencies. If there are symptoms of decompression sickness or gas embolism, immediate treatment by recompression is essential. Even without evidence of any ill effects, omitted decompression must be made up in some manner to avert later difficulty.

A. Use of Surface Decompression Tables

It may appear that surface decompression procedures offer an immediate solution to the problem of interrupted decompression because they provide for a surface interval. Such procedures, however, can only be used if the diver is at the 40-foot stop in accordance with instructions given in Section 15.7. At the chamber stop during surface decompression and emergency surface decompression, oxygen breathing may be interrupted at 30 minute intervals with a 5 minute air break. Consider time on air as dead time, and not a part of C_2 decompression. If interval falls on time to travel, commence traveling to the sur-

face at a rate of 8 feet per minute while breathing oxygen.

B. Surface Decompression Procedures are Not Applicable

When the conditions in the paragraph above are not fulfilled, the diver's decompression has been compromised. Even if the diver shows no ill effects from his omitted decompression, he needs immediate recompression. Take him to depth as appropriate for Treatment Table 5 or 1A if no oxygen is available. If he still shows no ill effects after being held at treatment depth for the required period of time, decompress him in accordance with the Treatment Table. Consider any decompression sickness developing during or after this procedure as a recurrence.

VARIATION IN RATE OF ASCENT 15.9

Travel to all stops should be on time. However, in the event you are unable to maintain the specified rate of travel to the first stop, and delay is deeper than 50 feet, increase bottom time by the difference between the time used in ascent and the time which should have been used.

Do not exceed the rate of travel. Time between stops is not critical as long as the specified time is given at each stop. Disregard any delay during travel from 40 feet to the surface during surface decompression unless the diver exceeds the 5 minute surface interval, in which case the diver must be treated for omitted decompression.

THE TEN COMMANDMENTS OF HE₂ EMERGENCY PROCEDURES

OVER 50'	LOST GAS	USE THE EMERGENCY AIR TABLE CAN SUR "D" AFTER COMPLETION OF 30' STOP.
50'	LOST GAS	SHIFT TO EMERGENCY HE-O ₂ OR AIR. CAN SUR "D" AFTER COMPLETION OF 30' STOP.
50'	O ₂ SYMPTOM	BRING DIVER UP 10', SHIFT TO EMERGENCY HE-O ₂ OR AIR. CAN SUR "D" AFTER COMPLETION OF 30' STOP.
40'	LOST GAS	IF NOT WITHIN SUR "D" LIMITS SHIFT STRAIGHT ACROSS TO EMERGENCY HE-O ₂ OR AIR. CAN SUR "D" AFTER COMPLETION OF 30' STOP.
40'	O ₂ SYMPTOM	IF NOT WITHIN SUR "D" LIMITS BRING DIVER UP 10' SHIFT TO EMERGENCY HE-O ₂ OR AIR. CAN SUR "D" AFTER COMPLETION OF 30' STOP.
40'	LOST GAS	WITHIN EMERGENCY SUR "D" LIMITS, SUR "D" AND DOUBLE THE MISSED TIME AND ADD TO THE CHAMBER STOP.
40'	O ₂ SYMPTOM	WITHIN EMERGENCY SUR "D" LIMITS, SUR "D" AND DOUBLE THE MISSED TIME AND ADD TO THE CHAMBER STOP.
40'	LOST GAS	WITHIN NORMAL SUR "D" LIMITS, SUR "D".
40'	O ₂ SYMPTOM	WITHIN NORMAL SUR "D" LIMITS, SUR "D".
SUR "D" CHAMBER	LOST GAS O ₂ SYMPTOM	REMOVE MASK, FOLLOW EMERGENCY AIR TABLE OF THAT DIVE. REMOVE MASK. ALLOW 15 MINUTES AFTER REACTION HAS SUBSIDED, AND RESUME TREATMENT AT POINT OF INTERRUPTION.

HELIUM-OXYGEN SURFACE SUPPLIED DECOMPRESSION TABLE

PARTIAL PRESSURE	BOTTOM TIME (MIN.)	TIME TO FIRST STOP (MIN.)	Decompression Stops (Feet)												TOTAL ASCENT TIME (MIN.)			
			180	170	160	150	140	130	120	110	100	90	80	70		60	50	40
60	10	4															0	4
	20	4															0	4
	30	4															0	4
	40	4															0	4
	60	4															0	4
	80	4															6	8
	100	2															9	11
70	10	2															9	11
	20	2															7	10
	30	2															10	13
	40	2															10	13
	60	2															17	20
	80	2															17	20
	100	2															25	28
	120	2															25	28
	140	2															29	32
	160	2															29	32
80	10	2															31	34
	20	2															31	34
	30	2															31	34
	40	2															31	34
	60	2															33	36
	80	2															33	36
	100	2															33	36
	120	2															33	36
	140	2															33	36
	160	2															33	36
90	10	2															33	36
	20	2															33	36
	30	2															33	36
	40	2															33	36
	60	2															33	36
	80	2															33	36
	100	2															33	36
	120	2															33	36
	140	2															33	36
	160	2															33	36

HELIUM-OXYGEN SURFACE SUPPLIED DECOMPRESSION TABLE

PARTIAL PRESSURE	BOTTOM TIME (MIN.)	TIME TO FIRST STOP (MIN.)	Decompression Stops (Feet)														TOTAL ASCENT TIME (MIN.)	
			180	170	160	150	140	130	120	110	100	90	80	70	60	50		40
100	10																19	19
	20																17	20
	30																24	27
	40																31	34
	60																47	50
	80																56	59
	100	3															63	66
	120																67	70
	140																72	75
	160																72	75
180																73	76	
200																73	76	
220																74	77	
240																75	78	
110	10																19	19
	20																21	24
	30																27	30
	40																39	42
	60																55	58
	80																67	70
	100																73	76
	120																78	81
	140																81	84
	160																83	86
180																84	87	
200																84	87	
220																85	88	
240																86	89	
120	20																25	28
	40																47	50
	60																63	66
	80																77	80
	100																87	90
	120																87	90
	160																92	95
	200																93	96
240																97	100	

HELIUM-OXYGEN SURFACE SUPPLIED DECOMPRESSION TABLE

PARTIAL PRESSURE	BOTTOM TIME (MIN.)	TIME TO FIRST STOP (MIN.)	Decompression Stops (Feet)													TOTAL ASCENT TIME (MIN.)			
			180	170	160	150	140	130	120	110	100	90	80	70	60		50	40	
130	20															0	29	32	
	40															0	53	56	
	80															0	86	89	
	120															0	96	99	
	160															10	92	105	
	200															10	94	107	
	240															10	96	109	
	140	20															0	34	37
40																0	62	65	
80																0	94	97	
120																10	97	110	
160																10	99	112	
200																13	99	115	
240																15	99	117	
150		20															0	10	28
	40															7	10	59	79
	80															7	10	90	110
	120															7	11	98	119
	160															8	15	99	125
	200															10	16	99	128
	240															12	16	99	130

HELIUM-OXYGEN SURFACE SUPPLIED DECOMPRESSION TABLE

PARTIAL PRESSURE	BOTTOM TIME (MIN.)	TIME TO FIRST STOP (MIN.)	Decompression Stops (Feet)												TOTAL ASCENT TIME (MIN.)							
			180	170	160	150	140	130	120	110	100	90	80	70		60	50	40				
160	10																0	0	10	33	53	
	20																0	7	10	33	53	
	30																0	7	10	65	85	
	40																0	7	10	65	85	
	50																0	7	10	96	116	
	60																0	7	10	96	116	
	80																0	9	16	99	127	
	100																0	18	16	99	136	
	120																0	22	16	99	140	
	140																7	19	16	99	144	
170	10																0	7	10	36	56	
	20																0	7	10	70	90	
	30																7	9	10	98	127	
	40																7	17	16	99	142	
	50																11	22	16	99	151	
	60																12	23	16	99	153	
	80																16	23	16	99	157	
	100																					
	120																					
	140																					
180	20																0	7	0	10	41	61
	40																0	7	4	10	77	101
	60																0	9	14	13	98	137
	80																7	9	21	16	99	155
	100																7	15	23	16	99	163
	120																7	19	23	16	99	167
	140																7	23	23	16	99	171

HELIUM-OXYGEN SURFACE SUPPLIED DECOMPRESSION TABLE

PARTIAL PRESSURE	BOTTOM TIME (MIN.)	TIME TO FIRST STOP (MIN.)	Decompression Stops (Feet)													TOTAL ASCENT TIME (MIN.)				
			180	170	160	150	140	130	120	110	100	90	80	70	60		50	40		
190	10													0	7	0	10	20	41	
	20													0	7	0	10	44	65	
	30													0	7	4	10	67	92	
	40													7	0	8	10	81	110	
	60													7	5	11	10	98	133	
	80													7	9	15	15	99	149	
	100	4												7	13	19	16	99	158	
	120													7	17	23	16	99	166	
	140													9	19	23	16	99	170	
	160													11	20	23	16	99	173	
	180													13	21	23	16	99	176	
	200													14	22	23	16	99	178	
	220													15	23	23	16	99	180	
240													17	23	23	16	99	182		
200	10													0	0	7	0	10	22	43
	20													0	7	0	2	10	50	73
	30													0	7	0	7	10	66	97
	40													0	7	4	9	10	84	118
	60													0	7	9	13	12	93	136
	80													7	3	13	18	15	99	159
	100	4												7	8	18	21	16	99	168
	120													7	8	20	23	16	99	177
	140													7	11	21	23	16	99	181
	160													7	15	23	23	16	99	187
	180													7	17	23	23	16	99	189
	200													7	18	23	23	16	99	190
	220													7	20	23	23	16	99	192
240													8	20	23	23	16	99	193	
210	10													0	7	0	0	10	25	46
	20													0	7	0	4	10	53	78
	30													7	0	9	7	10	74	106
	40													7	0	7	10	10	86	124
	60													7	4	10	14	13	98	150
	80													7	8	14	18	16	99	166
	100	4												7	12	17	23	16	99	178
	120													8	15	21	23	16	99	186
	140													10	17	21	23	16	99	190
	160													12	17	22	23	16	99	193
	180													14	18	22	23	16	99	196
	200													16	18	23	23	16	99	199
	220													17	19	23	23	16	99	201
240													18	20	23	23	16	99	203	

HELIUM-OXYGEN SURFACE SUPPLIED DECOMPRESSION TABLE

PARTIAL PRESSURE	BOTTOM TIME (MIN.)	TIME TO FIRST STOP (MIN.)	Decompression Stops (Feet)											TOTAL ASCENT TIME (MIN.)				
			180	170	160	150	140	130	120	110	100	90	80		70	60	50	40
220	20									0	0	7	0	0	10	57	85	
	40									0	7	0	0	7	10	90	133	
	60									7	0	0	17	17	13	99	188	
	80									7	3	11	15	20	13	99	172	
	100									7	0	14	18	23	16	99	188	
	120									7	8	18	23	23	16	99	198	
	140									7	11	18	23	23	16	99	201	
	160									7	14	19	23	23	16	99	205	
230	20									0	0	7	0	0	10	57	85	
	40									7	0	6	9	11	10	93	140	
	60									7	0	8	12	17	21	16	99	184
	80									0	7	8	12	17	21	16	99	184
	100									0	7	14	19	23	23	16	99	206
	120									0	8	14	19	23	23	16	99	206
	140									7	6	18	20	23	23	16	99	216
	160									7	9	19	20	23	23	16	99	220
240	20									0	0	7	0	0	10	57	85	
	40									0	7	0	1	4	7	10	85	98
	60									7	0	3	7	9	13	11	95	149
	80									7	3	10	14	18	23	16	99	194
	100									7	7	16	19	23	23	16	99	214
	120									7	13	19	20	23	23	16	99	224
	140									7	13	19	20	23	23	16	99	224
	160									8	17	19	20	23	23	16	99	229
200									8	17	19	20	23	23	16	99	229	
240									11	17	19	20	23	23	16	99	232	

HELIUM-OXYGEN SURFACE SUPPLIED DECOMPRESSION TABLE

PARTIAL PRESSURE	BOTTOM TIME (MIN.)	TIME TO FIRST STOP (MIN.)	Decompression Stops (Feet)												TOTAL ASCENT TIME (MIN.)					
			180	170	160	150	140	130	120	110	100	90	80	70		60	50	40		
250	20									0	7	0	2	5	7	10	68	103		
	40									7	0	5	8	9	14	12	96	155		
	80									0	7	7	11	16	18	23	16	99	201	
	120									7	3	12	17	19	23	23	16	99	223	
	160									7	7	16	19	19	23	23	16	99	233	
	200									7	11	17	19	20	23	23	16	99	239	
240									7	13	17	19	20	23	23	16	99	241		
260	20									7	0	0	3	7	7	10	70	108		
	40									7	2	5	9	9	14	13	96	159		
	80									7	3	9	13	15	21	23	16	99	210	
	120									7	8	13	19	20	23	23	16	99	232	
	160									8	13	17	19	20	23	23	16	99	242	
	200									10	16	17	19	20	23	23	16	99	247	
240									13	16	17	19	20	23	23	16	99	250		
270	20									0	7	0	2	4	6	7	10	74	114	
	40									7	0	3	8	9	10	15	14	96	166	
	80									0	7	6	10	13	17	23	23	16	99	218
	120									7	4	11	14	19	20	23	23	16	99	240
	160									7	7	15	17	19	20	23	23	16	99	250
	200									7	11	16	17	19	20	23	23	16	99	255
240									7	15	16	17	19	20	23	23	16	99	259	

HELIUM-OXYGEN SURFACE SUPPLIED DECOMPRESSION TABLE

PARTIAL PRESSURE	BOTTOM TIME (MIN.)	TIME TO FIRST STOP (MIN.)	Decompression Stops (Feet)													TOTAL ASCENT TIME (MIN.)			
			180	170	160	150	140	130	120	110	100	90	80	70	60		50	40	
280	10								0	7	0	0	2	3	4	10	42	72	
	20								7	0	0	2	6	6	8	10	78	121	
	30								7	6	3	6	6	8	13	16	93	151	
	40							7	0	2	5	8	8	12	16	13	98	173	
	60							7	0	6	8	10	14	19	23	16	99	206	
	80							7	3	6	11	14	17	23	23	16	99	225	
	100	4						7	5	11	13	16	20	23	23	16	99	237	
	120							7	8	12	16	19	20	23	23	16	99	247	
	140							7	10	16	17	18	20	23	23	16	99	254	
	160							8	13	16	17	19	20	23	23	16	99	258	
	180							8	14	16	17	19	20	23	23	16	99	260	
	200							10	15	16	17	19	20	23	23	16	99	262	
	220							12	15	16	17	19	20	23	23	16	99	264	
240							14	15	16	17	19	20	23	23	16	99	266		
290	10								0	0	7	0	0	3	3	4	10	46	77
	20								0	7	0	0	4	6	7	7	10	81	126
	30								7	0	1	5	5	9	9	12	10	96	158
	40							0	7	0	4	6	8	9	12	17	15	98	180
	60							0	7	4	6	8	12	15	18	23	16	99	212
	80							7	0	7	9	11	15	17	23	23	16	99	231
	100	4						7	2	9	11	15	17	20	23	23	16	99	246
	120							7	4	11	13	16	19	20	23	23	16	99	255
	140							7	5	13	16	17	19	20	23	23	16	99	262
	160							7	8	14	16	17	19	20	23	23	16	99	266
	180							7	10	15	16	17	19	20	23	23	16	99	269
	200							7	12	15	16	17	19	20	23	23	16	99	271
	220							7	13	15	16	17	19	20	23	23	16	99	272
240							7	14	15	16	17	19	20	23	23	16	99	273	
300	10					0	0	0	7	0	0	0	4	3	4	10	48	82	
	20					0	0	7	0	0	2	6	6	6	9	10	83	134	
	30					0	0	7	0	2	5	5	9	9	14	12	94	162	
	40					0	0	7	0	5	7	8	11	13	17	15	98	186	
	60					0	7	0	8	7	9	12	15	20	23	16	99	219	
	80					0	7	2	8	10	12	16	19	23	23	16	99	240	
	100	5				0	7	5	10	12	15	18	20	23	23	16	99	254	
	120					0	7	8	11	16	17	19	20	23	23	16	99	264	
	140					0	8	9	14	16	17	18	20	23	23	16	99	268	
	160					0	8	13	15	16	17	19	20	23	23	16	99	274	
	180					7	3	13	15	16	17	19	20	23	23	16	99	278	
	200					7	5	14	15	16	17	19	20	23	23	16	99	279	
	220					7	6	14	15	16	17	18	20	23	23	16	99	280	
240					7	9	14	15	16	17	19	20	23	23	16	99	283		

HELIUM-OXYGEN SURFACE SUPPLIED DECOMPRESSION TABLE

PARTIAL PRESSURE	BOTTOM TIME (MIN.)	TIME TO FIRST STOP (MIN.)	Decompression Stops (Feet)												TOTAL ASCENT TIME (MIN.)					
			180	170	160	150	140	130	120	110	100	90	80	70		60	50	40		
310	10					0	0	0	7	0	0	2	3	3	5	10	82	87		
	20				0	0	7	0	0	4	5	6	6	11	10	84	138			
	30				0	7	0	0	5	5	7	8	9	14	12	86	188			
	40				0	7	0	3	5	8	8	11	13	18	15	99	192			
	60				0	7	3	5	7	10	12	18	22	23	18	99	228			
	80				7	0	6	9	11	12	16	19	23	23	16	99	246			
	100	5			7	1	9	10	14	17	19	22	23	23	16	99	263			
	120				7	4	11	12	14	17	19	20	23	23	16	99	270			
	140				7	5	12	15	16	17	19	20	23	23	16	99	277			
	160				7	8	14	15	16	17	19	20	23	23	16	99	282			
	180				7	10	14	15	16	17	19	20	23	23	16	99	284			
	200				7	12	14	15	16	17	19	20	23	23	16	99	286			
220				8	13	14	15	16	17	19	20	23	23	16	99	288				
240				9	13	14	15	16	17	19	20	23	23	16	99	289				
320	10					0	0	0	7	0	0	0	3	3	5	10	82	87		
	20				0	0	7	0	0	2	4	5	6	7	10	85	141			
	30				0	0	7	0	2	4	5	7	8	11	10	85	141			
	40				0	7	0	1	4	6	7	8	12	15	19	16	99	199		
	60				0	7	0	3	5	8	9	11	13	17	20	23	16	99	231	
	80				0	7	3	7	9	11	13	17	20	23	23	16	99	253		
	100	5			0	7	5	8	11	13	17	19	20	23	23	16	99	267		
	120				0	7	7	12	13	16	17	19	20	23	23	16	99	277		
	140				7	2	9	12	15	16	17	19	20	23	23	16	99	280		
	160				7	3	11	14	15	16	17	19	20	23	23	16	99	288		
	180				7	5	13	14	15	16	17	19	20	23	23	16	99	292		
	200				7	6	13	14	15	16	17	19	20	23	23	16	99	293		
220				7	7	13	14	15	16	17	19	20	23	23	16	99	294			
240				7	9	13	14	15	16	17	19	20	23	23	16	99	296			
330	10																			
	20						0	0	7	0	0	3	5	5	6	8	10	88	147	
	30						0	7	0	4	4	6	7	9	12	16	20	16	99	205
	40						0	7	0	4	4	6	7	9	12	16	20	16	99	205
	60						7	0	6	8	8	13	14	19	20	23	23	16	99	261
	80						7	0	6	8	8	13	14	19	20	23	23	16	99	261
	100						7	4	9	12	13	16	17	19	20	23	23	16	99	283
	120						7	4	9	12	13	16	17	19	20	23	23	16	99	283
	160						7	8	13	14	15	16	17	19	20	23	23	16	99	295
	200						7	12	13	14	15	16	17	19	20	23	23	16	99	299
240						10	12	13	14	15	16	17	19	20	23	23	16	99	302	

HELIUM-OXYGEN SURFACE SUPPLIED DECOMPRESSION TABLE

PARTIAL PRESSURE	BOTTOM TIME (MIN.)	TIME TO FIRST STOP (MIN.)	Decompression Stops (Feet)													TOTAL ASCENT TIME (MIN.)		
			180	170	160	150	140	130	120	110	100	90	80	70	60		50	40
340	20		0	0	7	0	0	2	3	4	6	5	10	10	10	90	152	
	40		0	7	0	1	4	5	7	7	10	12	17	22	16	99	212	
	80		0	7	2	7	9	10	13	15	19	20	23	23	16	99	267	
	120		7	1	7	10	13	15	16	17	19	20	23	23	16	99	291	
	160		7	4	10	13	14	15	16	17	19	20	23	23	16	99	301	
	200		7	6	12	13	14	15	16	17	19	20	23	23	16	99	305	
240		7	10	12	13	14	15	16	17	19	20	23	23	16	99	309		
350	20		0	0	7	0	0	2	4	5	7	8	9	10	10	90	157	
	40		0	7	0	2	4	6	7	8	10	13	16	22	16	99	215	
	80		7	0	7	7	8	11	13	15	19	20	23	23	16	99	273	
	120		7	4	9	11	13	15	16	17	19	20	23	23	16	99	297	
	160		7	9	11	13	14	15	16	17	19	20	23	23	16	99	307	
	200		8	11	12	13	14	15	16	17	19	20	23	23	16	99	311	
240		11	11	12	13	14	15	16	17	19	20	23	23	16	99	314		
360	20		0	0	7	0	0	4	4	5	5	7	9	13	10	94	163	
	40		0	7	0	1	3	5	6	7	8	11	14	17	23	16	99	222
	80		0	7	2	7	7	10	11	13	17	19	20	23	23	16	99	279
	120		7	1	7	9	12	14	15	16	17	19	20	23	23	16	99	303
	160		7	4	10	12	13	14	15	16	17	19	20	23	23	16	99	313
	200		7	7	11	12	13	14	15	16	17	19	20	23	23	16	99	317
240		7	11	11	12	13	14	15	16	17	19	20	23	23	16	99	321	

MIXED-GAS SCUBA DECOMPRESSION

MIXED-GAS SCUBA DECOMPRESSION TABLES 16.1

The tables presented in this section provide decompression procedures for initial and repetitive dives made using constant mass-flow semiclosed-circuit SCUBA (MK 6) with various mixtures of helium-oxygen and nitrogen-oxygen. Additionally, emergency procedures for aborted decompression are provided.

The mixed-gas decompression tables are based upon the partial pressure of inert gas in the inhalation breathing bag of the SCUBA (not the partial pressure of the inert gas in the supply). This partial pressure requirement will be met as long as the mixed-gas flow rates are set as designated in Table 11-1 (page 11-16).

Helium-Oxygen SCUBA Decompression Table

16.1.1 At the present time, two gas mixtures are permitted for use in He-O₂ SCUBA diving. The standard mixture is 68 percent helium, 32 percent oxygen, and all decompression schedules relate to this mixture which can be used to a maximum depth of 200 feet for 30 minutes. The schedules in this table will also provide safe decompression from dives using a mixture of 60 percent helium-40 percent oxygen, provided the dives are limited to a maximum depth and bottom time of 80 feet for 100 minutes. Because of the higher oxygen percentage of this mixture, its use requires lower flow rates than the 32 percent oxygen mixture. Since the semiclosed-circuit SCUBA has a fixed supply of mixed gas, a lower supply flow rate permits longer dives. The intended use of the 40 percent oxygen mixture, therefore, is for long duration dives to 50 feet or less.

The decompression table for He-O₂ SCUBA is very similar to the Standard Air Decompression Table and is self-explanatory. This table permits repetitive diving, and consequently, repetitive group designators are included for each schedule. In using this table, the rate of descent should not exceed 75 feet per minute. The rate of ascent from the bottom and between stops should be 60 feet per minute.

EXAMPLE —

PROBLEM—A diver using a MK 6 SCUBA is to make a dive to 178 feet for 28 minutes. What is his decompression obligation?

SOLUTION—Select the next deeper and next longer decompression schedule. This would be the 180/30 schedule.

Procedure	Elapsed Decompression Time
	Min:Sec
1. Ascend from 178 feet to 40 feet at 60 feet per minute	2:18
2. Remain at 40 feet for 5 minutes	7:18
3. Ascend to 30 feet	7:28
4. Remain at 30 feet for 10 minutes	17:28
5. Ascend to 20 feet	17:38
6. Remain at 20 feet for 15 minutes	32:38
7. Ascend to 10 feet	32:48
8. Remain at 10 feet for 20 minutes	52:48
9. Ascend to surface	52:58

Helium-Oxygen SCUBA Decompression Table Using Oxygen 16.1.2

The same mixtures, flow rates, depth limitations and descent and ascent rates apply to the Helium-Oxygen SCUBA Table Using Oxygen as apply to the previous table. By administering pure oxygen to the diver during decompression, there is a significant saving in decompression time as compared with using helium-oxygen throughout the dive.

The semiclosed-circuit apparatus presently in use in the U. S. Navy is not normally provided with a capability for oxygen decompression. However, by the addition of a separate oxygen cylinder and injection system it can be adapted for this kind of decompression. If this type of adaptation is used, the shift to oxygen is made at the first oxygen stop (20 or 30 feet) in these schedules. At the first oxygen stop, the oxygen apparatus is activated and the helium-oxygen mixture injection is secured. The breathing bags are then purged thoroughly three times. The table allows 2 minutes to complete this procedure. The decompression time at the first oxygen stop does not start until

HELIUM-OXYGEN SCUBA DECOMPRESSION TABLE

Depth (ft)	Bottom time (min)	Time to first stop (min:sec)	Decompression stops (feet)					Total ascent time (min:sec)	Repetitive group
			50	40	30	20	10		
40									
50	200	0:40					20	20:50	L
60	150	0:50					20	21:00	L
70	100	1:00					15	16:10	K
	130	1:00					40	41:10	L
* 80	70	1:00				5	10	16:20	J
	90	1:00				10	25	36:20	K
90	60	1:10				5	10	16:30	J
	85	1:10				10	30	41:30	L
100	50	1:20				5	15	21:40	J
	70	1:10			5	15	25	46:40	K
110	40	1:30				5	10	16:50	H
	65	1:20			5	15	25	46:50	L
120	35	1:40				5	10	17:00	I
	55	1:30			10	15	20	47:00	L
130	30	1:50				5	10	17:10	I
	50	1:30		5	5	15	20	47:10	L
140	25	2:00				5	10	17:20	G
	45	1:40		5	5	15	25	52:20	K
150	20	2:10				5	10	17:30	G
	40	1:50		5	10	15	20	52:30	K

*Depth limit for use of 40 percent oxygen supply mixture.

HELIUM-OXYGEN SCUBA DECOMPRESSION TABLE

	Bottom time (min)	Time to first stop (min:sec)	Decompression stops (feet)					Total ascent time (min:sec)	Repetitive group
			50	40	30	20	10		
160	10						0	2:40	E
	20	2:10			5	5	10	22:40	G
	35	2:00		5	10	10	20	47:40	K
170	10						0	2:50	E
	20	2:20			5	5	10	22:50	H
	35	2:10		5	10	15	20	52:50	K
180	5						0	3:00	C
	10	2:40				5	10	18:00	E
	20	2:20		5	5	10	10	33:00	H
	30	2:20		5	10	15	20	53:00	K
*190	10	2:50				5	10	18:10	E
	20	2:30		5	5	10	20	43:10	H
	30	2:20	5	5	10	15	25	63:10	K
*200	10	3:00				5	15	23:20	F
	20	2:40		5	5	10	20	43:20	I
	30	2:30	5	5	10	15	35	73:20	K

*Numbers in red indicate exceptional exposures.

after the required 2 minutes allowed for oxygen purging have elapsed.

Oxygen decompression can also be accomplished even if the apparatus has not been adapted for this purpose. This can be done by supplying the diver with a surface-supplied source of oxygen which is delivered to a demand regulator at the required decompression depth. It should be noted that this procedure should only be used when the exact location of the diver is known. A pneumofathometer, attached alongside the oxygen supply hose, is the recommended method of measuring the diver's exact depth.

EXAMPLE—

PROBLEM—A diver using a MK 6 SCUBA is to make a dive to 178 feet for 28 minutes. His apparatus is equipped for oxygen breathing. What is his decompression obligation?

SOLUTION—Select the 180/30 schedule.

Procedure	Elapsed Decompression Time Min:Sec
1. Ascend from 178 feet to 40 feet at 60 feet per minute	2:18
2. Remain at 40 feet for 5 minutes	7:18
3. Ascend to 30 feet	7:28
4. Purge the breathing bags with oxygen 3 times	9:28
5. Breathe O ₂ at 30 feet for 10 minutes	19:28
6. Ascend to 20 feet	19:38
7. Breathe O ₂ at 20 feet for 20 minutes	39:38
8. Ascend to the surface	39:58

HELIUM-OXYGEN SCUBA DECOMPRESSION TABLE USING OXYGEN

Depth (ft)	Time (min)	He-O ₂		Decompression stops (min)		Repetitive group
		50 feet	40 feet	30 feet	20 feet	
60						
70	130				25	L
* 80	90				20	K
90	85				25	L
100	60				20	K
110	65			5	20	L
120	55			10	20	L
130	50		5	5	20	L
140	45		5	5	20	K
150	40		5	10	20	K
160	35		5	10	20	K
170	35		5	10	20	K
180	30		5	10	20	K
** 190	30	5	5	10	20	K
** 200	30	5	5	10	25	K

ALLOW 2 MINUTES TO COMPLETE BALANCE PURGE TO OXYGEN

*Depth limit for use of 40 percent oxygen supply mixture.
 **Numbers in red indicate exceptional exposures.

Helium-Oxygen SCUBA No-Decompression Limits Table 16.1.3

The He-O₂ SCUBA No-Decompression Limits Table is for use with 68% helium-32% oxygen to depths down to 180 feet of seawater, and with 60% helium-40% oxygen to depths down to 80 feet of seawater. The limits given in the column entitled "No-Decompression Limits" provide the maximum bottom time, corresponding to the diver's depth, which permits surfacing directly at 60 feet per minute.

All depths are given in feet of seawater and exposure times are given in minutes.

The remainder of the table is used in the same manner as the Air No-Decompression Limits Table to determine the diver's repetitive group designation following a no-decompression dive. Exposure limits for depths less than 40 feet are listed up to 12 hours although this exposure time is significantly beyond the field requirements for the table.

EXAMPLE--

PROBLEM-- A diver is to make a dive to 100 feet for 20 minutes using a MK 6 SCUBA. What is his repetitive group designation at the end of the dive?

SOLUTION-- A dive to 100 feet for 20 minutes is a no-decompression dive. Enter the He-O₂ SCUBA No-Decompression Limits Table at the 100 foot row and move horizontally to the 20 minute column. The repetitive group, found at the top of this column, is "D."

Helium-Oxygen SCUBA Residual Helium Timetable for Repetitive Dives 16.1.4

A helium-oxygen repetitive dive is a He-O₂ SCUBA dive made after a 30 minute surface interval and before 12 hours have elapsed. A second dive made prior to the 30 minute minimum surface interval is considered a continuation of the first dive. In this event, the bottom times of the first and second dives are added together to determine the appropriate decompression schedule of the second dive. If the surface interval is more than 12 hours, normal He-O₂ decompression procedures are used.

Procedures for computing the residual helium time are the same as those for computing the residual nitrogen time, except that a different timetable is used. Enter the Residual Helium Timetable along the diagonal line at the letter which corresponds with the diver's repetitive group designation from his previous

HELIUM-OXYGEN SCUBA NO-DECOMPRESSION LIMITS TABLE

Depth (ft)	No-decompression limits (min)	Repetitive groups (He-O ₂ dives)											
		A	B	C	D	E	F	G	H	I	J	K	L
20	25	60	95	145	215	335	720						
40	260	10	25	40	55	70	90	110	140	165	200	245	260
60	130	5	15	25	35	45	55	65	75	90	105	120	130
80	60	5	10	15	25	30	40	45	55	60			
100	35	5	10	15	20	25	30	35					
120	25	5	8	10	15	20	22	25					
140	15		5	10	12	15							
160	10		5	6	8	10							
180	5			5									

HELIUM-OXYGEN SCUBA RESIDUAL TIMETABLE FOR REPETTIVE DIVES

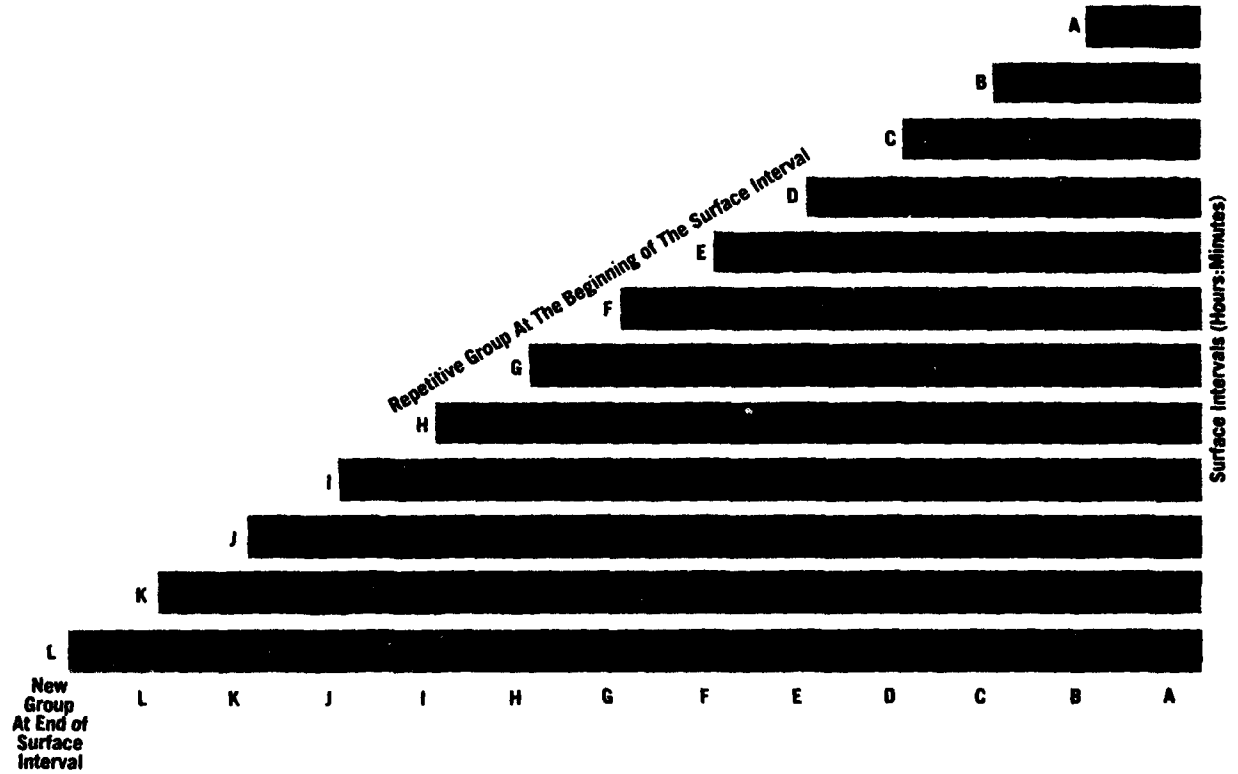

Repetitive Dive Depth (Feet)	L	K	J	I	H	G	F	E	D	C	B	A
40	305	248	203	168	139	115	93	74	56	40	26	13
60	137	120	105	92	79	67	56	45	35	26	17	8
80	91	80	72	64	55	47	40	33	26	19	13	6
100	68	61	55	49	43	37	31	26	20	15	10	5
120	55	49	45	40	35	30	26	21	17	13	8	4
140	46	42	37	33	29	26	22	18	14	11	7	4
160	40	36	32	29	26	22	19	16	13	9	6	3
180	35	32	28	26	22	20	17	14	11	8	6	3
200	31	28	25	23	20	18	15	13	10	8	5	3

Residual Helium Time (Minutes)

dive. Read horizontally to the interval in which the diver's surface interval lies. The time spent on the surface must be between or equal to the limits of the selected interval.

Next, read vertically downwards to the new repetitive group designation. This designation corresponds to the present quantity of residual helium in the diver's tissues. Continue downward in this same column to the row which represents the depth of the repetitive dive. The time given at the intersection is the residual helium time, in minutes, to be added to the actual repetitive dive bottom time.

In some instances, when the repetitive dive is to the same or greater depth than the previous dive, the residual helium time may be longer than the actual bottom time of the previous dive. In this event, add the actual bottom time of the previous dive to the actual bottom time of the repetitive dive to obtain the equivalent single dive time.

EXAMPLE—

PROBLEM—A previous dive was conducted to 143 feet for 23 minutes. The repetitive group designation following this dive was "J." The diver's surface interval has been 2 hours 20 minutes. He is to make a repetitive dive to 86 feet. What is his residual helium time?

SOLUTION—Enter the Residual Helium Timetable along the diagonal line at J. Read horizontally to the 2:01 interval, in which the diver's 2 hours 20 minute surface interval lies. Read vertically downward to find his new repetitive group designation; E.

Continue downward to the intersection of this column with the "90 FEET" row, which is the next greater depth than the repetitive dive depth. The residual helium time, located at this intersection is 29 minutes.

Nitrogen-Oxygen SCUBA Tables 16.1.5 Semiclosed-circuit, constant mass-flow SCUBA may also be used with nitrogen-oxygen, rather than helium-oxygen, mixtures. The Nitrogen-Oxygen SCUBA Table provides decompression procedures for this situation.

The fundamental principle of decompression from nitrogen-oxygen dives is that an **equivalent air depth** is established for the actual depth of the dive. The equivalent air depth is that depth at which the partial pressure of nitrogen in air (79% N₂) is equal to the average nitrogen partial pressure in the breathing bags of the semiclosed-circuit SCUBA. Using this equivalent air depth and the actual bottom time of the dive, the decompression schedule to be employed is selected from the Standard Air Decompression Table (Section 7.5.1, Volume 1). No credit is allowed for the fact that high-oxygen mixtures are breathed during decompression on the stops established for air decompression.

The Surface Decompression Table Using Oxygen (Section 7.5.4) or the Surface Decompression Table Using Air (Section 7.5.5) may be used routinely for decompression from nitrogen-oxygen dives. After the corresponding equivalent air depth is determined, either table may be used in the standard manner.

The Nitrogen-Oxygen SCUBA Table provides equivalent air depths for nonswimming and swimming dives, and for nitrogen-oxygen mixtures of 60, 40 and 32.5 percent oxygen. The maximum allowable bottom time for these dives is controlled by the exposure limits of the Oxygen Partial Pressure Limits Tables discussed in Section 9.3.2. In determining these limits the oxygen partial pressure in the supply mixture should be used.

Nitrogen-oxygen dives which expose the diver to exceptionally high concentrations of oxygen, as defined in the table of Oxygen Partial Pressure Limits For Exceptional Exposure, are printed in RED. Because of the increased potential of developing oxygen poisoning under these conditions, the exceptional exposure schedules should be used only in emergency situations as authorized by the Commanding Officer of the diving facility involved.

Nonswimming dive flow settings are required in ordnance disposal for brief exposures with minimal exertion in order that the exhaust can be reduced to avoid excessive sound production in the water. The decreased flow setting does not provide sufficient oxygen in the breathing mixture for dives with greater than minimal exertion.

EXAMPLE—

PROBLEM—A diver is to make a swimming dive to 86 feet using a mixture of 60% nitrogen-40% oxygen. What is the equivalent air depth of this dive, and what is the diver's maximum allowable bottom time?

SOLUTION—Enter the Nitrogen-Oxygen SCUBA Table for a 40% oxygen mixture in the column designated "Swimming dive flow setting 12 lpm." Follow that column down to the depth which is equal to or next greater than the depth of the dive; in this case it would be 97 feet. Move one column to the right to find the equivalent air depth; 80 feet. Move one column further to the right to find the maximum allowable bottom time; 30 minutes. If the diver uses his maximum bottom time, he will decompress according to the 80/30 schedule of the Standard Air Table which is a no-decompression dive.

Nitrogen-Oxygen Repetitive Dive Procedure 16.1.6

The Nitrogen-Oxygen SCUBA Table provides an equivalent air depth from which a decompression schedule in the Standard Air Table may be selected. This schedule, or possibly the No-Decompression Air Table, will designate a repetitive group for the surfaced diver.

If a repetitive dive is to be conducted, an equivalent air depth must be determined. Use the Nitrogen-Oxygen SCUBA Table to find the equivalent air depth corresponding to the depth of the repetitive dive. Using the diver's repetitive group designation at the beginning of the surface interval, his surface interval and the equivalent air depth, his residual nitrogen time is computed directly from the Residual Nitrogen Timetable (Section 7.5.3).

EXAMPLE—

PROBLEM—A diver completed a 60% nitrogen-40% oxygen dive according to the 80/30 schedule of the Standard Air Table 3 hours 28 minutes ago. He is about to begin a repetitive swimming dive to 66 feet on the same mixture. What is his residual nitrogen time?

SOLUTION—The diver's repetitive group designation at the beginning of his surface interval, found using the 80/30 schedule in the No-Decompression Air Table, was G. The equivalent air depth of the re-

petitive dive, using the Nitrogen-Oxygen SCUBA Table is 60 feet.

Enter the Residual Nitrogen Timetable at G and move horizontally to the ^{2:59}_{4:25} interval. Read downward to the intersection of the 60 foot repetitive dive depth row. The residual nitrogen time is 17 minutes.

Omitted Decompression in Emergencies—Mixed-Gas SCUBA 16.1.7

Certain emergencies may interrupt or prevent specified decompression. Blowup, exhausted gas supply, bodily injury, and the like are among such emergencies. If there are symptoms of decompression sickness or gas embolism, immediate treatment by recompression (Chapter Eight, Volume 1) is essential. Even without evidence of any ill effects, omitted decompression must be made up in some manner to avert later difficulty.

Use of Surface Decompression Tables 16.1.8

It may appear that surface decompression schedules offer an immediate solution to the problem of interrupted decompression because they provide for a surface interval. Such schedules should only be used, however, if the emergency surface interval occurs at such a time that water stops are not required or have already been completed in accordance with whichever surface decompression table is considered most appropriate.

Surface Decompression Tables Not Applicable 16.1.9

When the conditions in the paragraph above are not fulfilled, the diver's decompression has been compromised. Special care should be taken to detect signs of decompression sickness regardless of what action is initiated. The diver must be returned to pressure as soon as possible. The use of a recompression chamber, if available, is always preferable to in-water decompression.

A. WHEN A RECOMPRESSION CHAMBER IS AVAILABLE

Even if the diver shows no ill effects from his omitted decompression, he needs immediate recompression. Take him to depth as appropriate for Treatment Table 5 or 1A if no oxygen is available. If he shows no ill effects, decompress him in accordance with the Treatment Table. Consider any decompression sickness developing during or after this procedure as a recurrence.

NITROGEN-OXYGEN SCUBA TABLE

Oxygen Supply	Non-swimming dive flow setting	Actual depth up to - (feet)	Swimming dive flow setting	Actual depth up to - (feet)	Equivalent air depth (feet)	Maximum Allowable Bottom Time (Minutes)	
						Normal Exposure	Exceptional Exposure
60%	4 lpm	51	8 lpm	55	30	30	—
		51		65	30	→	60
		64		77	40	→	30
		77		—	50	→	30
40%	8 lpm	36	12 lpm	39	30	No Limit	—
		47		51	40	240	No Limit
		58		62	50	100	No Limit
		69		74	60	60	240
		80		85	70	45	160
		91		97	80	30	100
		102		108	90	→	80
		113		120	100	→	50
		124		131	110	→	30
		32.5%		12 lpm	33	21 lpm	35
44	46		40		No Limit		—
54	57		50		No Limit		—
65	68		60		240		No Limit
75	79		70		120		No Limit
86	89		80		80		No Limit
96	100		90		60		240
107	111		100		50		180
117	122		110		40		110
128	129		120		30		—
128	133		120		→		90
138	144		130		→		70
149	155		140		→		50
160	165		150		→		35
170	170		160		→		30

sickness developing during or after this procedure as a recurrence.

B. WHEN NO CHAMBER IS AVAILABLE

Recompress the diver in the water. Using the Helium-Oxygen SCUBA Decompression Table with helium-oxygen SCUBA and the Standard Air Decompression Table with nitrogen-oxygen SCUBA—

1. Repeat any stops deeper than 40 feet.
2. At 40 feet, remain for one-fourth of the 10-foot stop time.
3. At 30 feet, remain for one-third of the 10-foot stop time.
4. At 20 feet, remain for one-half of the 10-foot stop time.
5. At 10 feet, remain for 1½ times the scheduled 10-foot stop time.

Stops in the above procedure shall not be shorter than those in the table being used. Keep the diver at rest, provide a standby diver, and maintain good communications and depth control.

MARK 15 0.7 ATA CONSTANT PARTIAL PRESSURE OXYGEN IN NITROGEN 16.2

The table format is identical to that used in other parts of the U.S. Navy Diving Manual, i.e., all diving schedules are separated by white and light gray bars to minimize visual overlap. All dives not listed separately are covered in the tables by the next deeper or next longer schedule.

Specific instructions for use of decompression tables (0.7 ATA constant PPO₂ in N₂) are as follows:

1. Enter tables at the listed depth that is exactly equal to, or is the next greater than, the maximum depth attained during the dive.
2. Select bottom time of those listed for selected depth that is exactly equal to or is next greater than bottom time of planned dive.
3. Never attempt to interpolate between decompression schedules.

4. Use decompression stops listed on line for selected bottom time.

5. Ensure chest is maintained as close as possible to each decompression depth for number of minutes listed.

6. Ascent rate is 60 feet per minute or less.

7. Commence timing each stop on arrival at decompression depth and resume ascent when specified time has elapsed. Do not include ascent time as part of stop time.

8. Repetitive dives are not permitted using the 0.7 ATA Constant Oxygen Partial Pressure in Nitrogen Decompression Tables.

9. A surface interval of 12 hours must follow any dive requiring decompression.

10. Always use the appropriate decompression table when surfacing even if rig malfunction has significantly altered PPO₂.

Omitted Decompression in Emergencies 16.2.1

Certain emergencies may interrupt or prevent specified decompression. Rig failure, exhausted diluent or oxygen gas supply, blowup, bodily injury and the like constitute such emergencies. If the diver shows any symptoms of decompression sickness or gas embolism, immediate treatment using the appropriate oxygen, air or when available the PRC recompression treatment table is essential. Even without evidence of ill-effects, omitted decompression must be made up in some manner to avert later difficulty. The use of a recompression chamber when immediately available is mandatory.

A. WHEN A RECOMPRESSION CHAMBER IS AVAILABLE

Even if a diver shows no ill effects from his omitted decompression, he needs immediate recompression. Take him to depth as appropriate for treatment Table 5 or Table 1A, if no oxygen is available, or when available the PRC Table.

B. WHEN NO CHAMBER IS AVAILABLE

Recompress the diver in the water using the 0.7 ATA Constant PO₂ in N₂ Decompression Table. Descend

again to the depth of the last completed stop or to the deepest decompression stop if no stops were taken. Remain for one and one-half ($\times 1\frac{1}{2}$) the time listed for each decompression stop.

Keep the surface interval less than 5 minutes, if possible. The diver's MK 15 UBA must be checked to assure it will sustain the diver for the extended decompression obligation. Switching to a standby MK 15 UBA may be necessary so that the decompression time will not be compromised by depletion of gas supplies or carbon dioxide absorbent failure. Maintain depth control; keep the diver at rest; and, when possible, provide a standby diver.

PPO₂ Variances 16.2.2 The PPO₂ in the MK 15 UBA is expected to vary slightly from 0.7 ATA for irregular brief intervals. This does not constitute a mal-

function. The MK 15 decompression tables were calculated and tested using properly functioning MK 15 UBAs. When addition of O₂ to the rig is manually controlled, PPO₂ must be maintained as close to 0.7 ATA as possible.

When the PPO₂ exceeds 0.7 ATA for prolonged periods of time, the risk of oxygen poisoning increases. When the PPO₂ falls below 0.7 ATA, the diver inhales a greater percentage of inert gas than planned. The diving supervisor and medical personnel should recognize that a diver who has been breathing a mixture with PPO₂ lower than 0.7 ATA may have a greater risk of developing decompression sickness. Such a diver requires observation after surfacing but need not be treated unless symptoms of decompression sickness occur.

**MK 15 UNDERWATER DECOMPRESSION COMPUTER TABLES
0.7 ATA CONSTANT PARTIAL PRESSURE OXYGEN IN NITROGEN
(DESCENT RATE 60 FPM — ASCENT RATE 60 FPM)**

Depth (FSW)	Bottom time (min)	Time to first stop (min:sec)	Decompression stops (FSW)								Total ascent (min:sec)	
			90	80	70	60	50	40	30	20		10
40 50	150	0:40									4	4:50
	170	0:40									12	12:50
	190	0:40									19	19:50
	210	0:40									25	25:50
	230	0:40									33	33:50
	250	0:40									42	42:50
	270	0:40									49	49:50
	290	0:40									56	56:50
	310	0:40									62	62:50
	330	0:40									67	67:50
60	80	0:50									4	5:00
	100	0:50									13	14:00
	120	0:50									25	26:00
	140	0:50									39	40:00
	160	0:50									50	51:00
	180	0:40							4	59	64:00	
	200	0:40							12	65	78:00	
	220	0:40							19	71	91:00	
	240	0:40							25	76	102:00	
	260	0:40							30	82	113:00	
70	280	0:40							36	87	124:00	
	300	0:40							44	91	136:00	
	60	1:00								9	10:10	
	80	1:00								25	26:10	
	100	0:50							8	33	42:10	

**MK 15 UNDERWATER DECOMPRESSION COMPUTER TABLES
0.7 ATA CONSTANT PARTIAL PRESSURE OXYGEN IN NITROGEN
(DESCENT RATE 60 FPM — ASCENT RATE 60 FPM)**

Depth (FSW)	Bottom time (min)	Time to first stop (min:sec)	Decompression stops (FSW)										Total ascent (min:sec)	
			90	80	70	60	50	40	30	20	10			
70	110	0:50									12	30	62:10	
	120	0:50									16	45	62:10	
	130	0:50									20	57	71:10	
	140	0:50									22	56	79:10	
	150	0:50									26	55	87:10	
	160	0:50									36	62	99:10	
	170	0:50									43	55	107:10	
	180	0:50									48	70	119:10	
	190	0:40									53	73	127:10	
	200	0:40								2	57	76	136:10	
	210	0:40								6	57	80	144:10	
220	0:40								11	56	84	152:10		
80	30	1:20										0	1:20	
	40	1:10										1	2:20	
	50	1:10										15	16:20	
	60	1:10										27	28:20	
	70	1:00									0	28	30:20	
	80	1:00									18	28	47:20	
	90	1:00									25	34	59:20	
	100	0:50								3	28	42	74:20	
	110	0:50								6	28	30	87:20	
	90	20	1:30										0	1:30
40		1:20										14	15:30	
50		1:10									0	28	26:30	
60		1:10									17	28	46:30	
70		1:00								1	25	30	56:30	
80		1:00								10	29	34	74:30	
100	27	1:40										0	1:40	
	30	1:30										6	7:40	
	40	1:30										17	24:40	
	50	1:20									19	28	48:40	
	60	1:10								7	20	30	61:40	
110	23	1:50										0	1:50	
	25	1:40										3	4:50	
	35	1:40										14	28	43:50
	40	1:30										28	43:50	
120	15	1:00										0	1:00	
	20	1:50										1	3:00	
	25	1:40										4	24	30:00
	30	1:40										21	28	41:00
	50	1:20							2	21	28	28	81:00	
130	10	2:10										0	2:10	
	20	2:00										6	8:10	
	30	1:40							3	9	27	41:10		

**MK 15 UNDERWATER DECOMPRESSION COMPUTER TABLES
0.7 ATA CONSTANT PARTIAL PRESSURE OXYGEN IN NITROGEN
(DESCENT RATE 60 FPM — ASCENT RATE 60 FPM)**

Depth (FSW)	Bottom time (min)	Time to first stop (min:sec)	Decompression stops (FSW)								Total ascent (min:sec)		
			90	80	70	60	50	40	30	20		10	
140	15	2:10									2	4:20	
	25	1:50							4	7	21	34:20	
	35	1:40							5	13	38	43:30	
	40	1:30					1	10	16	28	29	86:20	
150	15	2:10									2	4	8:30
	25	1:50									7	11	21:30
	35	1:40							2	7	8	24	43:30
	40	1:30					1	7	13	27	29	68:30	

METRIC VERSION OF CONSTANT 0.7 ATA PO₂ IN N₂ DECOMPRESSION TABLES

Tables were calculated in 3-meters (9.84 feet) of seawater (MSW) increments in 3 MSW steps. Maximum bottom time has been restricted to 365 minutes. A 46 MSW (151 FSW) table is included so that the maximum depths for both the imperial and metric versions of these tables are the same.

**MK 15 UNDERWATER DECOMPRESSION COMPUTER TABLES
0.7 ATA CONSTANT PARTIAL PRESSURE OXYGEN IN NITROGEN
(DESCENT RATE 20 MPM — ASCENT RATE 20 MPM)**

Depth (MSW)	Bottom time (min)	Time to first stop (min:sec)	Decompression stops (MSW)								Total ascent (min:sec)			
			90	80	70	60	50	40	30	20		10		
12 15	305	0:36										0	0:36	
	140	0:45										0	0:45	
	150	0:36										1	1:45	
	160	0:36										5	5:45	
	170	0:36										9	9:45	
	180	0:36										13	13:45	
	190	0:36										15	15:45	
	200	0:36										18	18:45	
	210	0:36										21	21:45	
	220	0:36										24	24:45	
	230	0:36										29	29:45	
	240	0:36										32	32:45	
	250	0:36										37	37:45	
18	76	0:54										0	0:54	
	80	0:45										2	2:54	
	90	0:45										7	7:54	
	100	0:45										11	11:54	
	110	0:45										14	14:54	
	120	0:45										21	21:54	
	130	0:45										29	29:54	
	140	0:45										35	35:54	
	150	0:45										41	41:54	
	160	0:45										46	46:54	
	170	0:45										52	52:54	
	180	0:45										58	58:54	
	21	62	1:03										0	1:03
60		0:54										7	8:03	
70		0:54										15	16:03	
80		0:54										23	24:03	
90		0:45										31	32:03	
100		0:45										6	31	38:03

**MK 15 UNDERWATER DECOMPRESSION COMPUTER TABLES
0.7 ATA CONSTANT PARTIAL PRESSURE OXYGEN IN NITROGEN
(DESCENT RATE 20 MPM — ASCENT RATE 20 MPM)**

Depth (MSW)	Bottom time (min)	Time to first stop (min:sec)	Decompression stops (MSW)									Total ascent (min:sec)	
			90	80	70	60	50	40	30	20	10		
21	110	0:45									15	20	35:00
	120	0:45									14	43	58:03
	130	0:45									17	49	1:02:00
	140	0:45									19	55	75:03
	150	0:45									22	61	1:14:00
	160	0:45									32	60	93:03
	170	0:45									39	53	1:28:00
	180	0:45									44	68	113:03
	190	0:45									54	75	1:30:00
	200	0:45									54	75	130:03
210	210	0:36									7	56	145:03
	220	0:36									7	56	145:03
24	41	1:12										0	1:12
	50	1:03										13	14:12
	60	1:03										28	36:12
	70	0:54									7	28	36:12
	80	0:54									15	28	57:12
	90	0:54									23	33	57:12
	100	0:45									1	28	57:12
110	110	0:45									6	28	83:12
27	30	1:21										0	1:21
	40	1:12										13	14:21
	50	1:03										28	36:21
	60	1:03									15	28	44:21
	70	1:03									23	33	57:21
	80	0:54									8	28	70:21
30	20	1:30										0	1:30
	30	1:21										4	5:30
	40	1:21										28	37:30
	50	1:12									17	28	46:30
	60	1:03									5	28	63:30
33	24	1:30										0	1:30
	25	1:30										1	2:30
	30	1:30										28	39:30
	40	1:21									12	28	41:39
	50	1:12									5	28	62:39
36	20	1:48										0	1:48
	25	1:39										11	12:48
	30	1:30										28	35:48
	40	1:21									3	23	55:48
	50	1:12									21	28	76:48
39	15	1:57										0	1:57
	20	1:48										5	6:57
	25	1:39										4	12:57
	30	1:30									2	9	38:57
	40	1:30									15	28	60:57

**MK 15 UNDERWATER DECOMPRESSION COMPUTER TABLES
0.7 ATA CONSTANT PARTIAL PRESSURE OXYGEN IN NITROGEN
(DESCENT RATE 20 MPM — ASCENT RATE 20 MPM)**

Depth (MSW)	Bottom time (min)	Time to first stop (min:sec)	Decompression stops (MSW)								Total ascent (min:sec)		
			90	80	70	60	50	40	30	20		10	
42	15	1:57									2	4:06	
	25	1:39							3	7	20	32:06	
	40	1:30						10	15	28	28	83:06	
	45	1:30											
45	15	1:57									1	4	7:15
	25	1:39						2	7	7	23	41:15	
	40	1:30											
	45	1:30											
46	15	2:00									2	5	9:18
	25	1:42						4	6	8	24	44:18	
	40	1:30											
	45	1:30											

CHAPTER SEVENTEEN

HELIUM-OXYGEN SATURATION DIVING

The primary advantage of saturation diving is that the total decompression time is constant for any depth no matter how extended the dive. This allows the divers to remain at the working depths for durations which are not limited by decompression considerations. Also, by using the Unlimited Duration Excursion Tables and Procedures for Saturation Diving, the diver is allowed a wide vertical range of working depths without time limits or additions to the decompression time.

Helium-oxygen saturation diving requires operational procedures, chamber complexes, and life support systems which control precisely depth, oxygen partial pressure, carbon dioxide partial pressure, and temperature. Deviation from recommended standards may be immediately dangerous to the diver.

USN saturation diving procedures are as follows:

- A. Saturation DDC or Habitat Depth 17.1
- B. Emergency Gas Mixtures 17.2
- C. Treatment Gas Mixtures 17.3
- D. Underwater Breathing Apparatus Oxygen Partial Pressure 17.4
- E. Fire Protection 17.5
- F. Records 17.6
- G. DDC, Habitat and PTC Atmosphere Control 17.7
- H. Initial Compression to 22 feet 17.8
 - I. Life Support System Checkout at 22 feet 17.9
- J. Compression to Depth 17.10
- K. Excursion Limits 17.11
- L. Standard Saturation Decompression 17.12
- M. Decompression Sickness Treatment 17.13
- N. External Ear Prophylaxis 17.14

SATURATION DDC OR HABITAT DEPTH 17.1

Select the most convenient depths for the saturation DDC or habitat by comparing the planned working depths with the Ascent and Descent Limit Line graph of the Unlimited Duration Excursion Tables. The depth of the saturation DDC or habitat may be varied as convenient during a dive within the limits of the Unlimited Duration Excursion Tables and Procedures.

HELIUM-OXYGEN SATURATION DIVING

EMERGENCY GAS MIXTURES 17.2

Have available for emergency use the following gas mixtures having a range of oxygen partial pressure from 0.16 to 1.25 atmospheres:

Depth	Mix
0—200	84/16% He-O ₂
200—400	95/ 5% He-O ₂
400—1300	97/ 3% He-O ₂

TREATMENT GAS MIXTURES 17.3

Have available for treatment use the following gas mixtures having a range of oxygen partial pressure from 1.5 to 2.5 atmospheres (pure oxygen is used to the depth of 60 feet):

Depth	Mix
0—60	100% O ₂
60—100	40/60% He-O ₂
100—200	64/36% He-O ₂
200—350	79/21% He-O ₂
350—600	87/13% He-O ₂
600—1000	92/ 8% He-O ₂
1000—1600	95/ 5% He-O ₂

UNDERWATER BREATHING APPARATUS OXYGEN PARTIAL PRESSURE 17.4

The gas mixture supplied to the diver by the underwater breathing apparatus should be helium-oxygen with the following oxygen partial pressure:

Semiclosed-Circuit—Select the oxygen percentage and flow rate to maintain an oxygen partial pressure in the inspired gas generally between 0.8 and 1.0 atmosphere. (608 to 760 mmHg). Fluctuations of the inspired gas in semiclosed-circuit apparatus in the range between 0.5 atm and 1.5 atm (380 to 1140 mmHg) are acceptable.

Closed-Circuit—Adjust the apparatus for an oxygen partial pressure in a range from 0.4 to 1.2 atm (304 to 912 mmHg).

Demand Open-Circuit—Select an oxygen percentage to provide an oxygen partial pressure in the range of 0.4 to 1.2 atm (304 to 912 mmHg).

FIRE PROTECTION 17.5

Fire protection is also addressed in Section 10.9. When chambers are fitted with an automatic fire suppression system, these systems are to be energized and set in automatic whenever the chamber doors are closed and at a depth within "fire zone", provided the chambers are manned. The "fire zone" is defined as that zone of depth where the oxygen content is sufficient to support combustion. For chamber operation where the ppO_2 is maintained at 0.4 ATM, the "fire zone" will range from the surface (0 FSW) to 170 FSW. When different concentrations of oxygen exist inside the chambers, the "fire zone" can be determined according to the graph in Figure 10-14.

It is the duty of the dive officer, dive supervisor, watchstanders and dive team to maintain the chambers in as safe a condition as possible. Particular attention should be given to control of combustibles entering the chambers. The dive team should conduct periodic inspections and shall insure that all essential and non-essential combustibles are secured in the metal containers when not in use. Chambers are to be kept clean and free of trash and debris.

The following fire protection rules are to be in effect at all times the chamber doors are closed and divers are inside regardless of depth:

1. All bedding, sheets, pillow cases, pillows, blankets, mattresses, and mattress covers are to be made of fire retardant material.

2. The following material shall be allowed in the chambers only after the material has been inventoried and logged. Combustible material as authorized by the diving supervisor shall be logged in and out of the chambers and the diving supervisor shall be personally notified by the service lock operator.

(a) Reading material—(1) book per chamber occupant.

- (b) Notebook and pen or pencil—(1) each per chamber occupant.
- (c) Cotton bath towels—(1) per chamber occupant.
- (d) Newspaper—(1) copy per day
- (e) Personal effects—(1) each non-electric toothbrush, toothpaste, non-electric razor, non-aerosol shave cream, soap dish, comb, and dental floss per chamber occupant.
- (f) Approved footwear.

3. Essential combustible items inside the chambers shall be kept in the metal containers provided or a designated service lock whenever not in use. Non-essential combustible items such as candy bars, cookie boxes, etc. are to be kept to an absolute minimum and shall also be stored in the metal containers when not being consumed.

4. The following fire protection rules are to be in effect at all times the chamber doors are closed, divers are inside, and the chamber depth is within the fire zone.

- (a) Fire retardant clothing is to be worn by all personnel inside the chambers. One pair of Navy approved swim trunks or athletic shorts and approved footwear may be worn as an exception.
- (b) Bilge levels are to be checked daily. Trash is to be kept out of the bilge water.

5. The following are known and allowable exceptions to the fire protection rules:

- (a) Movie screen
- (b) Ice chest
- (c) All diving dress
- (d) Diving umbilicals, instrumentation, tubing, and wiring
- (e) Athletic shorts and footwear

RECORDS 17.6

1. An official bound diving log will be maintained at all times throughout the dive. It will contain a chronological record of the dive procedure and any significant events incident thereto. Time of operation of the CO_2 scrubbers and time of CO_2 absorbent replenishment

and service lock runs will also be recorded. Times will be recorded in plus time, with clock time recorded every 4 hours. Plus time starts when the chamber leaves the surface. A narrative of significant events is to be recorded on the top page by the Diving Officer (or Diving Supervisor) and Medical Officer (as necessary) each watch.

2. Master Protocol: A bound copy of the procedure will be maintained at the Control Station as the Master Copy. No alterations are to be made to it except by the Diving Officer personally. He is then to sign and date the alteration. Other changes in other copies will have no validity.

3. Chamber Atmosphere Data Sheet: Hourly readings of chamber pressure, temperature, humidity, oxygen, and carbon dioxide concentrations will be recorded on the data sheets provided. Gas chromatograph and total hydrocarbon results are to be recorded.

4. Service Lock Log: The following information will be recorded in the service lock log. Date, depth, clock time for leave surface or leave bottom, and items locked in and out.

5. Individual Dive Record (OPNAV 9940/1): Individual log sheets will be prepared by each subject upon completion of the dive.

6. Operational procedure check offs are to be properly completed and signed by the operator assigned, and are then to be signed by the Dive Supervisor and Diving Officer. All evolutions are to be conducted using the appropriate O.P. All OPS are to be filed by the Dive Supervisor.

7. The Gas King is to maintain a log of the state of the Gas Banks and also of the machinery status.

DDC, HABITAT AND PTC ATMOSPHERE CONTROL 17.7

Control the hyperbaric atmosphere in the saturation chamber and PTC to maintain the gaseous components as follows:

HELIUM-OXYGEN SATURATION DIVING

Oxygen Partial Pressure — 0.35 to 0.40 atmospheres (266 to 304 millimeters of mercury)

Carbon Dioxide Partial Pressure — Less than 0.0050 atmospheres (3.8 millimeters of mercury).

Nitrogen Partial Pressure — 1.5 atmospheres (1140 millimeters of mercury) or less.

Helium — Balance of total pressure.

Temperature — Regulate to the comfort of the divers. The transfer of heat away from or into the skin and respiratory tract of a diver at depth in a helium-oxygen environment is extremely rapid. Temperatures much above the comfort range in humid hyperbaric systems will quickly increase the diver's body temperature and may cause heat stroke and death. Temperatures a few degrees below the comfort range will cause distracting cold sensations and shivering which prevent the diver from performing well and safely. Continued cold exposure will cause hypothermia and eventual death.

Relative Humidity — Maintain the relative humidity between 50 and 80% with 50 to 60% the most desirable range for diver comfort and carbon dioxide scrubber performance.

INITIAL COMPRESSION TO 22 FEET 17.8

Initially, compress the chamber to 22 feet (6.7 meters) and establish an oxygen partial pressure of 0.35 to 0.40 atmospheres (266 to 304 mm Hg). Compression with air or 80% helium-20% oxygen will result in an appropriate oxygen partial pressure. The chamber also may be initially compressed with 100% helium while oxygen is added until the correct respirable

atmosphere is established if the divers breathe from BIBS during the pure helium compression.

LIFE SUPPORT SYSTEM CHECKOUT 17.9

At 22 feet, calibrate the oxygen sensors and adjust monitors to maintain an oxygen partial pressure of 0.35 to 0.40 atmospheres (266 to 304 mm Hg). Check life support systems to ensure proper function before continuing compression.

COMPRESSION TO DEPTH 17.10

Compress the chamber from the checkout depth of 22 feet to the selected depth at rates varying from 60 feet per minute to 1 foot per minute for depths to 300 feet depending upon operational needs. For dives deeper than 300 feet, compression rates may vary from 3 feet per minute to 1 foot per minute. Compressions to saturation depths deeper than 1000 feet require gradual diminution of the 1 foot per minute rate.

Rapid compression rates cause manifestations of the high pressure neurological syndrome and the divers may experience nausea, sweating, vertigo, tremor and loss of balance. Therefore, slow compression rates are desirable so that the divers arrive at the working depth with a feeling of well being and are able to start work promptly.

EXCURSION LIMITS 17.11

The **UNLIMITED DURATION EXCURSION TABLES AND PROCEDURES FOR SATURATION DIVING** were developed to allow the diver a wide vertical range of working depths during a saturation dive. Within the depth limits of the tables, a diver may ascend or descend without regard to the number or duration of these excursions. The tables have no time limits, only depth limits.

The tables and procedures are for use with saturation diving depths between 150 and 1000 feet of sea water. Excursions shallower than 150 feet have not been investigated and risk decompression sickness.

The rate of descent or compression should not exceed 60 feet per minute during an excursion. The rate of ascent or decompression during an excursion

must not exceed 60 feet per minute. Whenever it is detected that a diver is ascending faster than 60 feet per minute, the diver should stop his ascent immediately and wait the time that should have been taken. He may then recommence his ascent or decompression at a rate not to exceed 60 feet per minute from that depth.

Two tables are provided for unlimited duration excursions. The first lists the **Limits for Excursions DEEPER than a Chosen Depth**. The first column lists the diver's Initial Depth. The middle column lists the corresponding Deepest Excursion Distance the diver may descend from that Initial Depth. The third column is the sum of the Initial Depth plus the Deepest Excursion Distance and is the Deepest Excursion Depth permitted. To determine the Deepest Excursion Distances for depths which lie between the Initial Depths listed, use the Initial Depth which corresponds to the shorter Deepest Excursion Distance and the shallower Deepest Excursion Depth.

EXAMPLES—

PROBLEM 1.—If a diver were at 370 FSW, how deep could he descend to work and return directly to 370 FSW?

SOLUTION—370 FSW has been chosen as the Initial Depth and the unknowns are the Deepest Excursion Distance and the Deepest Excursion Depth. Reading across from 370 FSW in the Initial Depth column, the Deepest Excursion Distance is 101 feet, the distance the diver may descend from his Initial Depth and return again. The diver may descend 101 feet deeper for any period of time and return directly to 370 FSW. His Deepest Excursion Depth would be 370 + 101 feet or 471 FSW.

PROBLEM 2—If a diver were at 532 FSW, how deep could he descend to work and return directly to 532 FSW?

SOLUTION—532 FSW is the Initial Depth and it lies between the listed Initial Depths of 530 and 540 FSW. To determine the Deepest Excursion Distance for depths which lie between the Initial Depths listed, use

the Initial Depth which corresponds to the shorter Deepest Excursion Distance. Reading across from the Initial Depth of 530 FSW, the distance is 123 feet. Reading across from the Initial Depth of 540 FSW, the distance is 124 feet. Use the Initial Depth which corresponds to the shorter Deepest Excursion Distance, 530 FSW. Therefore, from 532 FSW, the diver may make an excursion to the Deepest Excursion Depth of 653 FSW and return again to 532 FSW.

The second table lists the Limits for Excursions **SHALLOWER** than the Deepest Depth of the Dive. The first column lists depths between 150 and 1000 FSW defined as the Deepest Depth attained at any time during the dive. The middle column lists the corresponding Shallowest Excursion Distance the diver may ascend from the Deepest Depth of the dive. The third column is the Deepest Depth of the dive minus the Shallowest Excursion Distance and is the Shallowest Excursion Depth permitted. To determine the Shallowest Excursion Depth for depths which lie between the Deepest Depths listed, use the Deepest Depth which corresponds to the deeper Shallowest Excursion Depth.

EXAMPLES—

PROBLEM 1.—If the diver is at 270 FSW and has been no deeper the entire saturation dive, what is his limit for an excursion ascent?

SOLUTION—The diver's Deepest Depth of the Dive is 270 FSW. Reading across to the Shallowest Excursion Distance column, the limit is a distance of 76 feet. This is 76 feet shallower than his starting depth of 270 FSW and corresponds to the Shallowest Excursion Depth limit of 194 FSW. The diver may make excursions to 194 FSW without regard to the number or duration of these excursions.

PROBLEM 2.—If a diver is at 650 FSW undergoing Standard Saturation Decompression from a 1000 FSW dive, may he make an excursion ascent?

SOLUTION—Absolutely not, the Limits for Excursions **SHALLOWER** than the Deepest Depth of the Dive permit an excursion ascent from 1000 FSW

to 820 FSW. The diver is already much shallower than the limit.

PROBLEM 3.—If a diver at 670 FSW plans an excursion descent to the Deepest Excursion Depth limit, 812 FSW, inadvertently loses depth control and sinks to 850 FSW, to what shallower depth may he return at 60 feet per minute?

SOLUTION—Select the Limits for Excursions **SHALLOWER** than the Deepest Depth of the Dive table and find the diver's Deepest Depth of the Dive, 850 FSW. Reading across to the next two columns, the table allows the diver to ascend 147 feet to the Shallowest Excursion Depth of 703 FSW. The PTC and DDC must be compressed to this deeper depth to allow the safe return of the diver.

Plan dive operations and DDC or habitat depths using the graph of the Unlimited Duration Excursion Tables (Figure 17-2). Normally, the saturation chamber (DDC or Habitat) will be at a depth convenient for the work site depth, planned excursion distances and umbilical lengths. Position the PTC as close to the work site as possible and choose umbilical lengths so that uncontrolled ascents, such as loss of buoyancy control, would not allow the diver to ascend above the Limits for Excursions **SHALLOWER** than the Deepest Depth of the Dive.

Figure No. 17-3 illustrates in Cases 1 and 2 how the PTC can be positioned at a depth such that the length of umbilical will prevent the diver from exceeding the Shallowest Excursion Depth. For example, the Deepest Depth of the dive has been 300 feet. The PTC may be positioned anywhere in the water column from 300 feet to the Shallowest Excursion Depth, 220 feet. If an 80 foot horizontal excursion were required, the PTC should be positioned at 300 feet. In this case, if the diver ascended out of control, he could not exceed the Ascent Limit. More practically, the PTC will be positioned near the middle of the water column, allowing both ascents and descents as required. Case 3 illustrates the worst case. The PTC is located at the Shallowest Excursion Depth. The diver making an 80-foot descent from the PTC could rise 80 feet above the Ascent Limit if his ascent were uncontrolled.

UNLIMITED DURATION EXCURSION TABLES

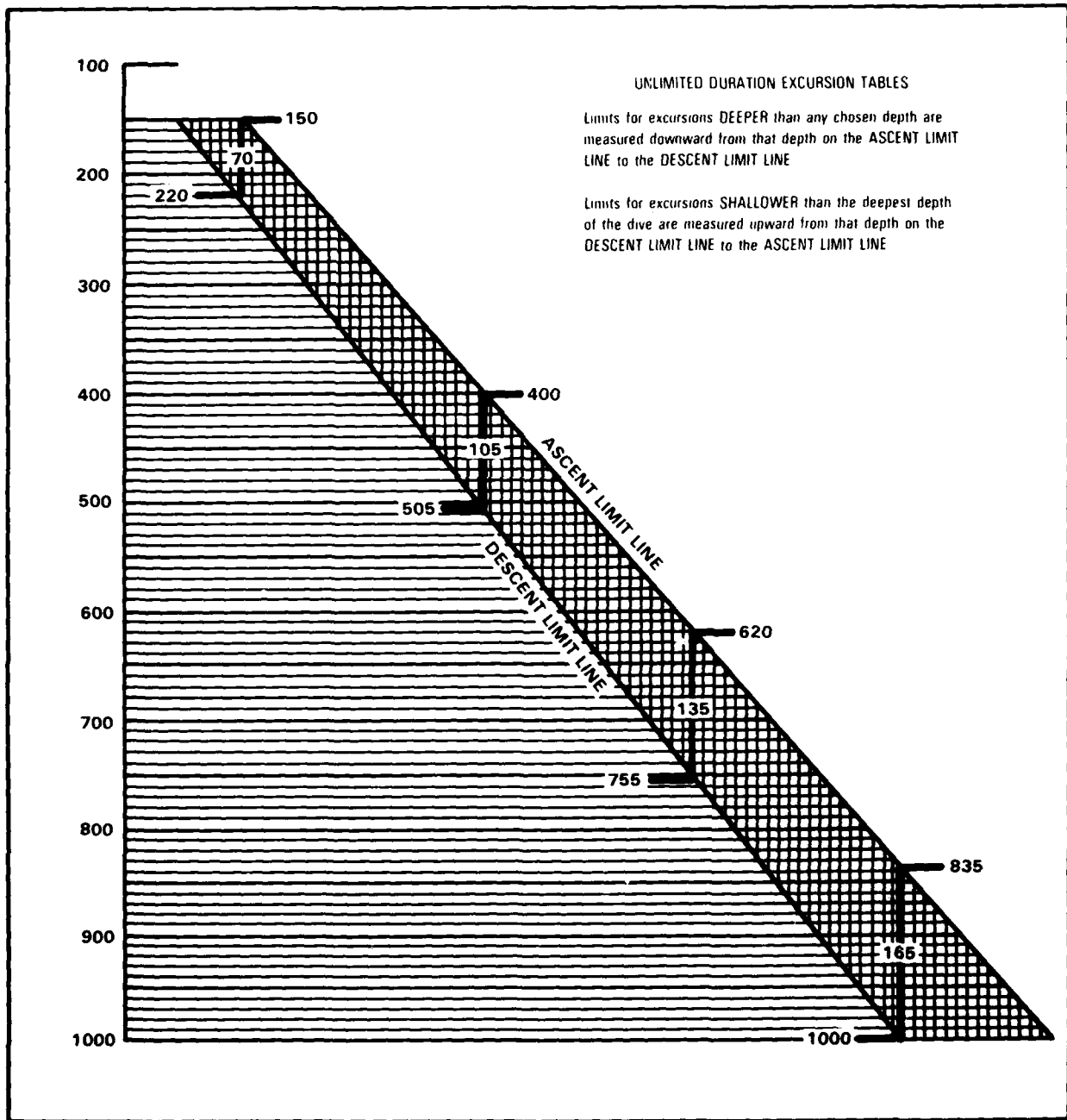

Figure 17-2

ascents may be more severe and involve the cardio-respiratory system, the central nervous system and the organs of special sense.

Serious decompression sickness is a medical emergency and requires immediate recompression. Treatment should not be delayed in less serious cases of pain-only complaints.

Treat serious decompression sickness resulting from an excursion ascent by immediate recompression at 30 feet per minute to at least the depth from which the excursion ascent originated. If there is not complete relief at that depth, recompression should continue deeper until relief is accomplished.

Treat decompression sickness manifested only as musculoskeletal pain and occurring during Standard Saturation Decompression by recompression in increments of 10 feet at 5 feet per minute until distinct **IMPROVEMENT IS INDICATED BY THE DIVER**. In most instances, improvement continues to complete resolution of the symptoms. Recompression more than 30 feet is usually not necessary.

At treatment depth, a treatment mixture may be given by mask to provide an oxygen partial pressure of 1.5 to 2.5 atmospheres. Pure oxygen may be used at treatment depths of 60 feet or less. Interrupt the mask

treatment every 20 minutes with 5 minutes of breathing the chamber atmosphere.

Remain at the treatment depth a minimum of 12 hours in serious decompression sickness, and a minimum of 2 hours in pain-only decompression sickness.

Resume the Standard Saturation Decompression Schedule from the treatment depth. Excursion ascents must not be performed.

NOTE

The Limits for Excursions have been reduced since introduction in Change 1, January 1977.

EXTERNAL EAR PROPHYLAXIS 17.14

External ear prophylaxis should be provided to diving personnel to prevent ear infections. External otitis can be prevented by use of 2% acetic acid in aluminum acetate solution each morning, evening, and following each wet dive. The head is tilted to one side and the canal gently filled with the solution. The solution must remain in the ear canal for 5 minutes. The head is then tilted to the other side to allow the solution to run out. The procedure is repeated in the other ear. The five-minute duration that the solution remains in each ear is critical to the success of the prophylaxis. The dive supervisor should observe and time ear prophylaxis.

UNLIMITED DURATION EXCURSION TABLE

Limits for Excursions DEEPER than a Chosen Depth

Initial Depth (FSW)	Deepest Excursion Distance (ft)	Deepest Excursion Depth (FSW)	Initial Depth (FSW)	Deepest Excursion Distance (ft)	Deepest Excursion Depth (FSW)
150	70	220	500	119	619
160	71	231	510	120	630
170	73	243	520	121	641
180	74	254	530	123	653
190	76	266	540	124	664
200	77	277	550	125	675
210	78	288	560	127	687
220	80	300	570	128	698
230	81	311	580	130	710
240	82	322	590	131	721
250	84	334	600	132	732
260	85	345	610	134	744
270	87	357	620	135	755
280	88	368	630	137	767
290	89	379	640	138	778
300	91	391	650	139	789
310	92	402	660	141	801
320	94	414	670	142	812
330	95	425	680	144	824
340	96	436	690	145	835
350	98	448	700	146	846
360	99	459	710	148	858
370	101	471	720	149	869
380	102	482	730	150	880
390	103	493	740	152	892
400	105	505	750	153	903
410	106	516	760	155	915
420	107	527	770	156	926
430	109	539	780	157	937
440	110	550	790	159	949
450	112	562	800	160	960
460	113	573	810	162	972
470	114	584	820	163	983
480	116	596	830	164	994
490	117	607	835	165	1000

UNLIMITED DURATION EXCURSION TABLE

**Limits for Excursions SHALLOWER than the
Deepest Depth of the Dive**

Deepest Depth (FSW)	Shallowest Excursion Distance (ft)	Shallowest Excursion Depth (FSW)	Deepest Depth (FSW)	Shallowest Excursion Distance (ft)	Shallowest Excursion Depth (FSW)
150	0	150	580	114	466
160	10	150	590	115	475
170	20	150	600	116	484
180	30	150	610	118	492
190	40	150	620	119	501
200	50	150	630	120	510
210	60	150	640	121	519
220	70	150	650	122	528
230	71	159	660	124	536
240	72	168	670	125	545
250	74	176	680	126	554
260	75	185	690	127	563
270	76	194	700	128	572
280	77	203	710	130	580
290	79	211	720	131	589
300	80	220	730	132	598
310	81	229	740	133	607
320	82	238	750	135	615
330	83	247	760	136	624
340	85	255	770	137	633
350	86	264	780	138	642
360	87	273	790	139	651
370	88	282	800	141	659
380	89	291	810	142	668
390	91	299	820	143	677
400	92	308	830	144	686
410	93	317	840	146	694
420	94	326	850	147	703
430	96	334	860	148	712
440	97	343	870	149	721
450	98	352	880	150	730
460	99	361	890	152	738
470	100	370	900	153	747
480	102	378	910	154	756
490	103	387	920	155	765
500	104	396	930	156	774
510	105	405	940	158	782
520	107	413	950	159	791
530	108	422	960	160	800
540	109	431	970	161	809
550	110	440	980	163	817
560	111	449	990	164	826
570	113	457	1000	165	835

UNLIMITED DURATION EXCURSION TABLE

Limits for Excursions DEEPER than a Chosen Depth

Initial Depth (MSW)	Deepest Excursion Distance (M)	Excursion Depth (MSW)	Initial Depth (MSW)	Deepest Excursion Distance (M)	Excursion Depth (MSW)
46	21	67	130	33	163
48	22	70	132	33	165
50	22	72	134	34	168
52	22	74	136	34	170
54	22	76	138	34	172
56	23	79	140	34	174
58	23	81	142	35	177
60	23	83	144	35	179
62	24	86	146	35	181
64	24	88	148	36	184
66	24	90	150	36	186
68	24	92	152	36	188
70	25	95	154	36	190
72	25	97	156	37	193
74	25	99	158	37	195
76	26	102	160	37	197
78	26	104	162	37	199
80	26	106	164	38	202
82	26	108	166	38	204
84	27	111	168	38	206
86	27	113	170	39	209
88	27	115	172	39	211
90	27	117	174	39	213
92	28	120	176	39	215
94	28	122	178	40	218
96	28	124	180	40	220
98	29	127	182	40	222
100	29	129	184	41	225
102	29	131	186	41	227
104	29	133	188	41	229
106	30	136	190	41	231
108	30	138	192	42	234
110	30	140	194	42	236
112	31	143	196	42	238
114	31	145	198	42	240
116	31	147	200	43	243
118	31	149	202	43	245
120	32	152	204	43	247
122	32	154	206	44	250
124	32	156	208	44	252
126	32	158	210	44	254
128	33	161	212	44	256

AD-A112 710

NAVAL SEA SYSTEMS COMMAND WASHINGTON DC F/6 13/10
U S NAVY DIVING MANUAL. VOLUME 2. MIXED-GAS DIVING. REVISION 1.(U)
JUL 81

UNCLASSIFIED

NAVSEA-0994-LP-001-9020-2

NL

3 3

3

3

3

3

3

3

3

3

3

3

3

3

3

3

3

3

3

3

3

3

3

3

3

3

3

3

3

3

3

3

3

3

3

3

3

3

3

3

3

3

3

3

3

3

3

3

3

3

3

END
DATE
FILED
4 82
DTIC

3 OF

3

AD-

A112710

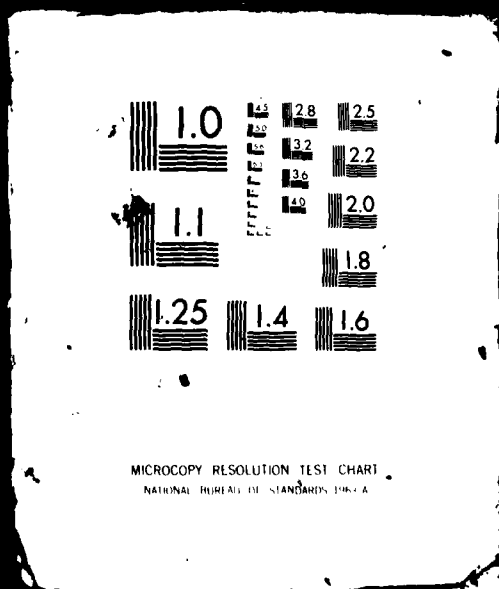

UNLIMITED DURATION EXCURSION TABLE

Limits for Excursions DEEPER than a Chosen Depth

Initial Depth (MSW)	Deepest Excursion Distance (M)	Excursion Depth (MSW)	Initial Depth (MSW)	Deepest Excursion Distance (M)	Excursion Depth (MSW)
214	45	259	236	48	284
216	45	261	238	48	286
218	45	263	240	48	288
220	46	266	242	49	291
222	46	268	244	49	293
224	46	270	246	49	295
226	46	272	248	49	297
228	47	275	250	50	300
230	47	277	252	50	302
232	47	279	254	50	304
234	47	281	256	50	306

UNLIMITED DURATION EXCURSION TABLE

**Limits for Excursions SHALLOWER than the
Deepest Depth of the Dive**

Deepest Depth (MSW)	Shallowest Excursion Distance (M)	Shallowest Excursion Depth (MSW)	Deepest Depth (MSW)	Shallowest Excursion Distance (M)	Shallowest Excursion Depth (MSW)
46	0	46	128	29	99
48	2	46	130	29	101
50	4	46	132	29	103
52	6	46	134	29	105
54	8	46	136	30	106
56	10	46	138	30	108
58	12	46	140	30	110
60	14	46	142	30	112
62	16	46	144	31	113
64	18	46	146	31	115
66	20	46	148	31	117
68	21	47	150	31	119
70	22	48	152	32	120
72	22	50	154	32	122
74	22	52	156	32	124
76	22	54	158	32	126
78	23	55	160	33	127
80	23	57	162	33	129
82	23	59	164	33	131
84	23	61	166	33	133
86	24	62	168	34	134
88	24	64	170	34	136
90	24	66	172	34	138
92	24	68	174	34	140
94	25	69	176	35	141
96	25	71	178	35	143
98	25	73	180	35	145
100	25	75	182	35	147
102	26	76	184	36	148
104	26	78	186	36	150
106	26	80	188	36	152
108	26	82	190	36	154
110	27	83	192	37	155
112	27	85	194	37	157
114	27	87	196	37	159
116	27	89	198	37	161
118	28	90	200	38	162
120	28	92	202	38	164
122	28	94	204	38	166
124	28	96	206	38	168
126	29	97	208	39	169

UNLIMITED DURATION EXCURSION TABLE

**Limits for Excursions SHALLOWER than the
Deepest Depth of the Dive**

Deepest Depth (MSW)	Shallowest Excursion Distance (M)	Shallowest Excursion Depth (MSW)	Deepest Depth (MSW)	Shallowest Excursion Distance (M)	Shallowest Excursion Depth (MSW)
210	39	171	260	45	215
212	39	173	262	45	217
214	39	175	264	45	219
216	39	177	266	46	220
218	40	178	268	46	222
220	40	180	270	46	224
222	40	182	272	46	226
224	40	184	274	47	227
226	41	185	276	47	229
228	41	187	278	47	231
230	41	189	280	47	233
232	41	191	282	48	234
234	42	192	284	48	236
236	42	194	286	48	238
238	42	196	288	48	240
240	42	198	290	48	242
242	43	199	292	49	243
244	43	201	294	49	245
246	43	203	296	49	247
248	43	205	298	49	249
250	44	206	300	50	250
252	44	208	302	50	252
254	44	210	304	50	254
256	44	212	306	50	256
258	45	213			

UNLIMITED DURATION EXCURSION TABLE

FSW

Deepest Excursion Distance (feet) = $0.1387 \times \text{Initial Depth} + 49.2$

Shallowest Excursion Distance (feet) = $0.1218 \times \text{Deepest Depth} + 43.2$

MSW

Deepest Excursion Distance (meters) = $0.1387 \times \text{Initial Depth} + 15.0$

Shallowest Excursion Distance (meters) = $0.1218 \times \text{Deepest Depth} + 13.2$

APPENDIX A

MK 6 MOD 0 MIXED-GAS SCUBA

Pre-Dive Equipment Preparation Checklist A.1

The MK 6 MOD 0 Mixed-Gas SCUBA uses standard air SCUBA accessories such as wetsuit, swim fins, knife, mask, etc. Preparation for MK 6 mixed-gas diving is essentially the same as that for air SCUBA diving with the exception that considerably more attention need be paid to the breathing supply and to proper preparation of the equipment system itself.

1. Lay out the MK 6 apparatus on a clean surface.
2. Make sure that all equipment needed for the dive (or that may possibly be used during the dive) is on the station.

Minimum Equipment

- Swim trunks or wet suit
- MK 3 life preserver (with 2 pair of 31-gram CO₂ cartridges activated by one Lanyard)
- Belt and knife
- Fins
- Face Mask
- MK 6 SCUBA and standby gear

—Charging Assembly (Fig. A-1)

- Depth gage
- Wristwatch

Optional Equipment

- Wrist compass
- Signal Flare
- Slate
- Lifeline
- Floats
- Protective Clothing

3. Check the gas supply to ensure that the mixture is correct as required by the depth and duration of the specific dive. Ensure that an adequate supply of proper breathing mixture is on hand to completely service the divers (and standby divers) throughout all phases of the operation. Be sure that an emergency supply is available.

4. Check the descending line.
5. Check the recompression chamber.
6. Take accurate depth soundings.
7. Brief the diving team.
8. Fill MK 6 cylinders—

A Remove the canister assembly from the backplate by removing the cylinder spreader bar from the cylinder lugs. Disconnect the cylinder block at the gas inlet block by unthreading the canister hose. Unthread the hoses connecting the canister to the breathing bag and vest assembly, and slide the canister up and out of the lip of the backplate.

B Remove the regulator assembly and the control block assembly (Figure A-2) from the backplate by disconnecting the pull rod, removing the spring, and loosening the regulator yoke assembly.

C Recharge the cylinders with the proper gas mixture selected for the dive. Do not exceed 3,000 psi.

D In filling the cylinders, avoid all contact with oil and grease. Follow all procedures set forth in Appendix C, Paragraph C.4 for the handling of oxygen cylinders.

E Open the manifold shutoff valve first to bleed off any gas that may remain in the cylinder.

F Connect the charging line assembly to the manifold valve assembly.

G Slowly open the valve of the high-pressure gas supply source and fill the cylinders to the desired pressure.

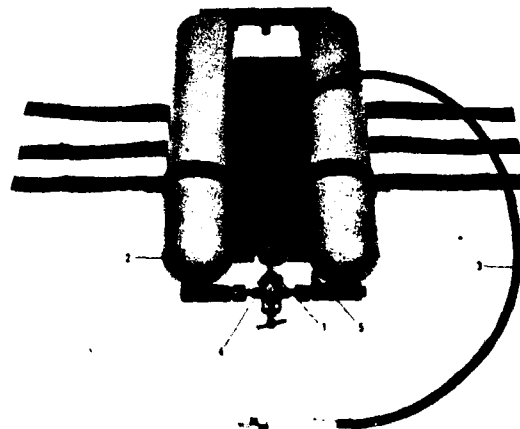

1 Manifold Shut-off Valve
2 Cylinders
3 Charging Line Assembly
4 Manifold Valve Assembly
5 Stem Gauge

Figure A-1 Cylinder charging assembly

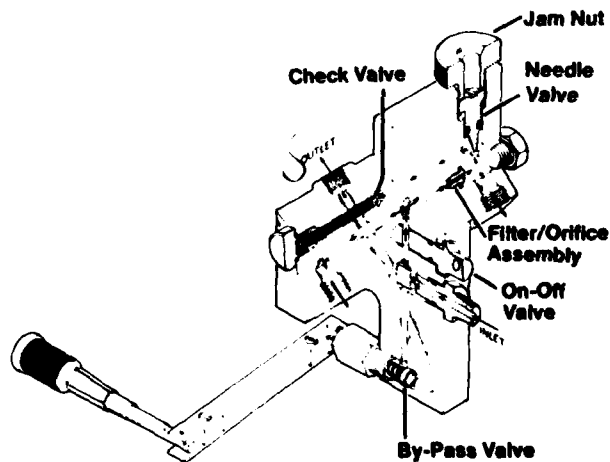

Figure A-2 Control block assembly

Do not exceed a filling rate of 500 psi per minute to avoid rapid heating during charging.

H Close the manifold shut-off valve and the high-pressure gas supply source valve. Bleed the charging line assembly at the high-pressure source. Disconnect the charging line assembly from the manifold valve.

I When charging is complete, tag the cylinders to indicate the exact composition of the gas mixture used to fill the cylinder and the pressure to which cylinder has been filled.

If the mixture used is a change from the gas previously filled in the cylinder, empty the cylinders and flush thoroughly using a 100 psi charge of the new gas mixture before filling to the required capacity.

9. Install the appropriate filter and orifice assembly by removing the access cap from the control block. Check to make sure that the proper assembly is being used. Replace the access cap.

10. Fill the MK 6 canister assembly (Figure A-3):

A Turn the canister assembly upside down.

B Unthread the screws retaining the canister cover assembly. Remove the cover.

C Inspect the screen assembly for any contamination or damage. Place the screen assembly in the inner canister.

D Place the canister filling collar inside the canister to prevent Baralyme pellets from entering between the inner and outer canister shells.

E Fill the inner canister with fresh granular Baralyme pellets. Tap the canister regularly to insure that channels do not form between the pellets.

F When filled, remove the filling collar, replace the cover assembly and retaining screws.

G Gently blow absorbant dust from canister by blowing down the left (outboard) canister hose.

H Leak test the canister (taking care not to over-pressurize).

11. Turn the canister rightside up.

12. Reconnect the regulator assembly and the control block assembly to the backplate by connecting the pull rod and tightening the yoke assembly.

13. Secure the filled canister to the backplate—

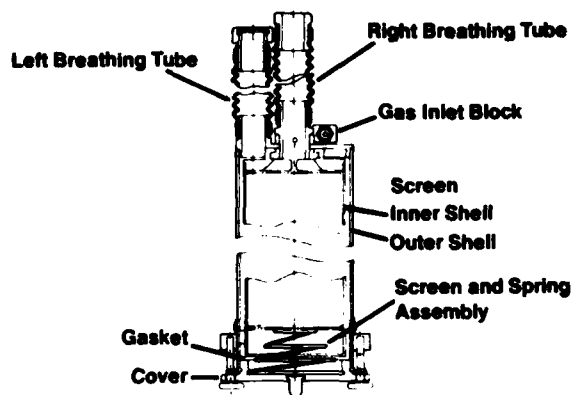
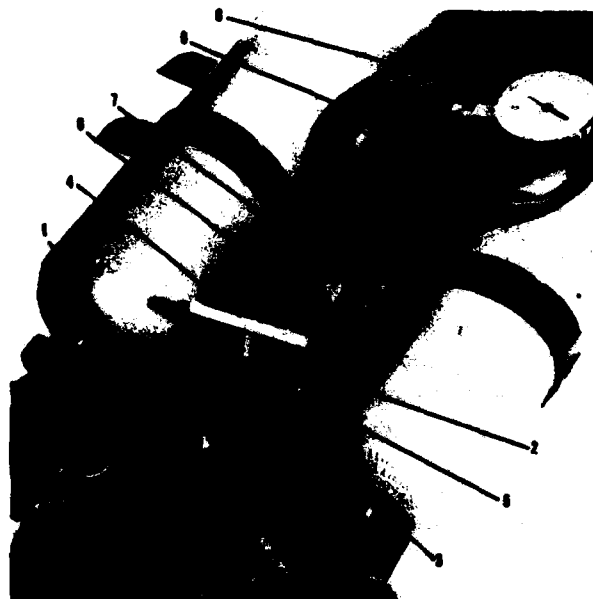

Figure A-3 Cross section of the MK 6 canister.



- 1 Manifold Shut-off Valve
- 2 Control Block ON-OFF Valve
- 3 Spring Button
- 4 Wrench
- 5 Fittings
- 6 Control Block to Canister Hose
- 7 Air Inlet Block
- 8 Pressure Gauge
- 9 Test Hose

Figure A-4 Regulator assembly

- A Position the canister assembly on the backplate so that the canister is hooked under the lip provided on the backplate.
 - B Replace the cylinder spreader bar.
 - C Mate the control block to the canister hose at the gas inlet block.
 - D Reconnect the hoses to the breathing bag and vest assembly.
14. Adjust the regulator and control block assemblies (Figures A-4 and A-5) for the proper pressure setting and flow:
- A Make all adjustments following accepted procedures to ensure proper differential pressure readings.
 - B Verify that the manifold shutoff valve and the control block on/off valve are in the OFF position.
 - C Actuate the bypass valve by pulling the ring several times.
 - D Back off the regulator spring button in a counter-clockwise direction using the special wrench provided. Back off fully.

DO NOT BACK OFF THE SPRING BUTTON WITH PRESSURE ON THE REGULATOR

- E Check that all differential pressure gage fittings on the control block are plugged.
- F Disconnect the control block to the canister hose at the gas inlet block junction, and connect a pressure gage and test hose to the end of the control block. Be sure that the pressure gage has been calibrated.
- G Place the control block on/off valve in the ON position.
- H Slowly open the manifold shutoff valve.
- I Adjust the regulator for the required pressure depending on the filter and orifice assembly used in the control block.
- J Wait two minutes and check adjustment. This is a critical function, and no slippage of the adjustment can be tolerated.
- K Turn the control block on/off valve to the OFF position. Bleed off trapped gas by disconnecting the pressure gage.
- L Actuate the bypass valve by pulling the ring several times.

- M Connect the pressure gage to the end of the test hose and place the on/off valve in the ON position.
 - N Check the pressure gage. The reading should be identical to that observed before actuation of the bypass valve. If correct, place the on/off valve in the OFF position and remove the gage.
- Adjust the MK 6 for the proper liter flow—
- A Check that the control block on/off valve is in the OFF position.
 - B Verify that the manifold shutoff valve is OPEN.
 - C Loosen the needle valve jam nut, turn the valve gently clockwise until closed (a standard 3/16 inch screwdriver is used).



- | | |
|-------------------------------|------------------------------------|
| 1. Control Block ON-OFF Valve | 7. Plugs |
| 2. Manifold Shut-off Valve | 8. Control Block |
| 3. Jam Nut | 9. Fittings |
| 4. Needle Valve | 10. Control Block to Canister Hose |
| 5. Test Hose | 11. Air Inlet Block |
| 6. Flowmeter | |

Figure A-5 Control block assembly

D Connect the end of the test hose to the proper inlet on the flowmeter.

E Control block on/off valve is placed in the ON position.

F Back off the needle valve and jam nut simultaneously until the proper flow registers on the meter. This function is critical. Wait two minutes, recheck the flowmeter reading. It must be steady without any fluctuation.

G If the flowmeter reads satisfactorily, hold the needle valve in place with the screwdriver and tighten the jam nut.

H Place the control block on/off valve in the OFF position.

I Remove the plugs from the control block.

J Connect the differential pressure gage to the control block fittings.

K Place the control block on/off valve in the ON position.

L Check the indication of the differential pressure gage. The needle must be in the safety area.

M Disconnect the test hose from the flowmeter.

N Actuate the bypass valve by pulling the ring several times.

O Connect the test hose to the flowmeter and recheck the indicator on both the flowmeter and the differential pressure gage.

The reading on the flowmeter must be identical to that observed before actuation of the bypass valve. The differential pressure gage indicator needle must be in the safety area. If this is not the case, do not use the gear until the situation is corrected.

P Place the control block on/off valve in the OFF position.

Q Disconnect the test hose.

R Re-connect the control block to the canister hose at the gas inlet block.

16. Check the breathing apparatus for leakage either by submerging in water or by soap test. Submergence is preferred.

17. Check the mouthpiece T-tube assembly.

A Place the mouthpiece and shutoff valve in the DIVING position.

B Place the mouthpiece in the mouth, squeeze the inhalation (right) hose closed, and attempt to inhale. If it is possible to inhale with the hose closed off, then the check valve is either missing or defective. This must be corrected before using the gear.

C Squeeze the exhalation (left) hose closed and attempt to exhale. If it is possible to exhale with the hose closed, then the check valve is either missing or defective. This too, must be corrected before any use of the apparatus.

D Place the mouthpiece shutoff valve in the SURFACE position.

18. The MK 6 SCUBA is now ready for use.

19. Don the accessory equipment and the MK 6 SCUBA—

A Put on the vest with all equipment attached and intact. Zip up and adjust the straps until comfortable.

B Place the mouthpiece in the mouth. Put the mouthpiece valve in the DIVING position and adjust the system exhaust valve.

21. Signal readiness to the Diving Supervisor.

TROUBLESHOOTING CHART A.2

SYMPTOM	PROBABLE CAUSE	POSSIBLE REMEDY
Mouthpiece T-tube assembly		
High inhalation resistance	Contaminated or faulty check valve	Clean or replace inhalation check valve
High inhalation and exhalation resistance	Mouthpiece and shutoff valve not in <i>DIVING</i> position	Place valve in <i>DIVING</i> position
High exhalation resistance	Contaminated or faulty exhalation check valve	Clean or replace exhalation check valve
Leakage at hose connections	Improper connections Faulty gasket	Tighten connections Replace gasket
Exhaust valve assembly		
Leakage	Contamination Loose clamp assembly Broken or weak spring Deteriorated or cut diaphragm assembly	Disassemble and clean valve Tighten clamp assembly Replace spring Replace diaphragm assembly
Regulator assembly		
No output	Manifold shutoff valve closed	Open valve
Restricted flow	Contaminated inlet filter	Clean or replace filter
Unable to adjust properly	Damaged first-stage component or bellows assembly	Inspect and replace filter or bellows assembly
Leakage through diaphragm cap	Deteriorated or cut diaphragm assembly or top diaphragm gasket	Replace as necessary
No depth compensation	Punctured or broken bellows assembly	Replace bellows assembly
Leakage at inlet	Faulty inlet seal	Tighten yoke assembly or replace preformed packing
Cylinder and manifold valve assembly		
Leakage at neck of cylinders	Faulty preformed packing	Replace preformed packing
Leakage at manifold connections	Loose fittings Damaged fittings	Tighten fittings Replace manifold valve assembly or defective elbow assembly
Leakage at manifold shutoff valve	Damaged or scored valve seat Faulty gasket Loose or damaged diaphragm cap	Replace retainer assembly Replace gasket Tighten or replace diaphragm cap

TROUBLESHOOTING CHART A.2 (cont'd)

SYMPTOM	PROBABLE CAUSE	POSSIBLE REMEDY
Control block assembly Unable to obtain proper system flow	Needle valve not properly adjusted Incorrect or damaged filter and orifice assembly	Adjust needle valve Change or replace filter and orifice assembly
Leakage at bypass valve	Faulty preformed packing gasket Worn or scored valve seat	Replace defective parts as necessary Replace valve stem assembly
Leakage at access caps Leakage at fittings	Faulty preformed packings Loose or damaged couplings	Replace preformed packings Tighten or replace as necessary
Canister assembly Leakage at bottom end of canister Leakage at upper end of canister	Loose cover assembly or faulty sealing gasket Faulty sealing gasket Loose or damaged hose clamp assemblies Gas inlet block loose	Tighten cover and/or replace sealing gasket Replace sealing gasket Replace hose clamp assemblies as required Tighten gas inlet block
Breathing bag and vest assembly Leakage at breathing bags	Loose elbow(s) Loose band assembly Water drain plugs not secure Damaged breathing bag(s)	Tighten elbow(s) Tighten band assembly Tighten plugs Replace breathing bag(s)

APPENDIX B

ACCIDENT/INCIDENT EQUIPMENT STATUS

The number of diving accidents/incidents which involve U.S. Navy divers is small compared to the total number of dives conducted each calendar year. However, the accidents/incidents which do occur must receive a thorough review in order to identify the cause and perhaps determine corrective measures to prevent further fleet mishaps. At the present time, dive accidents are more commonly blamed on diver error rather than equipment malfunction. Due to the inability of fleet dive units to thoroughly test the divers' equipment following a mishap, inadequate performance of life-support equipment may go undetected.

The U.S. Navy Experimental Diving Unit (NEDU) has the capability to perform full unmanned testing of all Navy diving equipment under all types of pressure and environmental conditions. Depth, water turbidity and temperature can be duplicated for all conceivable U.S. Navy dive scenarios.

In an effort to assist Fleet units with investigations and data collection following diving accidents/incidents, the dive equipment involved in such mishaps may be forwarded to NEDU for full unmanned testing. The results of such a test will provide specific data indicating if the equipment performs in accordance with specifications, and if not, it will identify the deficient areas.

In order to duplicate a Fleet dive scenario, NEDU must receive a complete narrative of the dive, in addition to the applicable information included in Table B-1. The following items must be identified in the narrative:

- A. Surface conditions:
 - Sea state
 - Surface current
 - Surface air temperature
 - Surface water temperature

- B. Bottom conditions:

- Bottom current
- Water temperature

- C. Length of:

- Bottom time
- Decompression time
- Total time of dive

The diver-mounted dive equipment involved in the accident/incident must be packaged and forwarded to:

Commanding Officer
Navy Experimental Diving Unit
Panama City, Florida 32407
Attn: Test and Evaluation
Department

Data pertaining to topside conditions will be noted in Table B-1 as will the flask pressure of all dive rigs. SCUBA bottles and MK 15/MK 16 bottles will not be shipped with the equipment in order to speed delivery.

Upon receipt of the equipment, NEDU will conduct unmanned tests, and the equipment will then be returned to the appropriate activity. NEDU will not retain the equipment; and, although the tests will be conducted as swiftly as possible, replacement equipment will be located by NEDU in the event immediate operational requirements prevail.

It must be noted that the NEDU Test and Evaluation capability is a service available to Fleet Units, and it is not a mandatory requirement following all accidents/incidents which may occur. The Command Dive Officer/Command Master Diver should determine when unmanned testing of dive equipment following a dive accident/incident is warranted.

TABLE B-1 Accident/Incident/Equipment Status

UBA	NUMBER OF TURNS TO SECURE TOPSIDE GAS UMBILICAL SUPPLY	NUMBER OF TURNS TO SECURE VALVE ON EMERGENCY BAIL-OUT BOTTLE	NUMBER OF TURNS TO SECURE GAS SUPPLY AT MASK/HELMET	NUMBER OF TURNS TO SECURE GAS BOTTLES/ BOTTLE PRESSURE	CONDITION OF ELECTRONIC READOUTS	BATTERY LEVEL	CONDITION OF CANISTER
MK 12				MIXED GAS EMERGENCY BOTTLE	N/A	N/A	
MK 1				EMERGENCY BOTTLE PRESSURE	N/A	N/A	N/A
SCUBA	N/A	N/A	N/A	AIR BOTTLE PRESSURE	N/A	N/A	N/A
MK 15	N/A	N/A	CONDITION OF MOUTHPIECE SURFACE DIVE	O ₂ DIL PRESSURE	PRIMARY SECONDARY	PRIMARY	
MK 16	N/A	N/A	CONDITION OF MOUTHPIECE SURFACE DIVE	O ₂ DIL PRESSURE	PRIMARY SECONDARY	PRIMARY SECONDARY	
MK 6	N/A	N/A	CONDITION OF MOUTHPIECE SURFACE DIVE	GAS BOTTLE PRESSURE	N/A	N/A	

*ACTION PROVIDE WRITTEN DESCRIPTION OF ACCIDENT/INCIDENT PACK DIVE GEAR FOR SHIPMENT. SEND TO: COMMANDING OFFICER
 NAVY EXPERIMENTAL DIVING UNIT
 PANAMA CITY, FLORIDA 32407

APPENDIX C

DIVING GASES—PURITY STANDARDS AND CYLINDER DATA

Purity Standards and Cylinder Data C.1 Oxygen—Military Specification MIL-0-27210 series, Oxygen, Aviator's Breathing, Liquid and Gas

Type 1 (gaseous) oxygen, and Type 2 (liquid) oxygen when gasified, may be used for diving/hyperbaric breathing oxygen. Type 1 oxygen, and Type 2 oxygen when gasified, shall contain not less than 99.5 percent pure oxygen by volume. The remainder, except for moisture and the minor constituents listed in Table C-1, shall be argon and nitrogen. Moisture shall not exceed 0.005 milligram of water vapor per liter of gas at 70°F (21.1°C) and 760 millimeters of mercury. The oxygen shall contain no odor. Type 2 oxygen shall contain no particles with any dimension larger than 1,000 microns, nor fibers longer than 6,000 microns. The total solids contained in the liquid shall not exceed 1.0 milligram per liter.

Nitrogen—Federal Specification BB-N-411 series, Nitrogen, Technical

This specification does not take into specific consideration the use of nitrogen for breathing. In obtaining nitrogen for breathing mixtures, the supplier should be informed of the intended use, and consulted concerning the possibility of harmful substances in the grade to be dived. Type 1 (gaseous), Class 1 (oil-free) nitrogen is suitable for use in diver's breathing mixtures. Non-oil-free nitrogen must never be used for diving. Authorized nitrogen is available in three grades—

Grade A - 99.95 percent pure, low moisture content, no solids

Grade B - 99.5 percent pure, low moisture content

Grade C - 99.5 percent pure, no moisture content specified

The composition of pure nitrogen shall be as listed in Table C-2.

Helium—Military Specification MIL-P-27407 series, Propellant Pressurizing Agent Helium

Type 1 (gaseous), Grade B (respirable) helium is authorized for diving and hyperbaric breathing. It must be 99.997 percent pure helium, and have a dew point of not higher than -78°F (-61.1°C). The maximum allowable impurities, expressed in ppm by volume, are listed in Table C-3.

Compressed Air—NAVSEA 0994-001-9010, USN Diving Manual, Volume 1 Federal Specification BB-A1034 series, Air, Compressed, for Breathing Purposes

Diver's breathing air shall normally conform to the criterion of the USN Diving Manual. When cylinders of compressed air must be secured from commercial sources, it must conform to FED SPEC BB-A-1034, Source 1 (supplied in a pressurized container), Grade A (high purity, very low water content) breathing air. Diver breathing air must conform to either set of specifications listed in Table C-4. Breathing air shall be sampled, as required, at intervals not to exceed six months, in accordance with the USN Diving Manual.

TABLE C-1 Constituent Concentrations for Pure Oxygen

Constituent	Maximum Concentration in ppm by Volume	
	Type 1	Type 2
Carbon Dioxide (CO ₂)	10	5
Methane (CH ₄)	50	25
Acetylene (C ₂ H ₂)	0.1	0.05
Ethylene (C ₂ H ₄)	0.4	0.2
Ethane (C ₂ H ₆) and other hydrocarbons	6 (C ₂ H ₆ equivalent)	3 (C ₂ H ₆)
Nitrous Oxide (N ₂ O)	2	1
Halogenated Compounds:		
Refrigerants (Freons, etc.)	2	1
Solvents (Trichloroethylene, Carbon Tetrachloride, etc.)	0.2	0.1
Other (each discernible from background noise on infrared spectrophotometer)	0.2	0.1

TABLE C-2 Composition of Pure Nitrogen

Constituent	Grade A	Grade B	Grade C
Nitrogen or inert gas (minimum, by volume)	99.95%	99.5%	99.5%
Active contaminants (maximum, by volume)	0.5%	0.5%	0.5%
Moisture (maximum)	0.02 mg/l	0.02 mg/l	Not Specified
Solids	None Visible	Not Specified	Not Specified

TABLE C-3 Impurity Limits for Pure Helium

Constituent	Maximum Concentration (ppm by volume)
Water (H ₂ O)	9
Hydrocarbons (as Methane (CH ₄))	1
Oxygen (O ₂)	3
Nitrogen and Argon (N ₂ , Ar)	5 (total)
Neon (Ne)	23
Hydrogen (H ₂)	1

TABLE C-4 Pure Air for Diving

Constituent	USN Diving Manual	FED SPEC BB-A-1034
Oxygen (O ₂) (percent by volume)	20 - 22%	20 - 23%
Carbon Dioxide (CO ₂) (by volume)	1,000 ppm (max.)	500 ppm (max.)
Carbon Monoxide (CO) (by volume)	20 ppm (max.)	10 ppm (max.)
Total Hydrocarbons (as CH ₄ , by volume)	25 ppm (max.)	25 ppm (max.)
Oil, Mist, Particulates (weight/volume)	5 mg/m ³ (max.)	.005 mg/l (max.)
Odor	Not objectionable	Not pronounced or objectionable
Separated Water	Not specified	None
Total Water (weight/volume)	Not specified	.02 mg/l (max.)
Nitrogen Dioxide (NO ₂) (by volume)	Not specified	2.5 ppm (max.)
Nitrous Oxide (N ₂ O) (by volume)	Not specified	2.0 ppm (max.)
Sulfur Dioxide (SO ₂) (by volume)	Not specified	2.5 ppm (max.)
Halogenated Compounds:		
Refrigerants (by volume)	Not specified	2.0 ppm (max.)
Solvents (by volume)	Not specified	0.2 ppm (max.)
Acetylene (C ₂ H ₂) (by volume)	Not specified	0.1 ppm (max.)
Ethylene (C ₂ H ₄) (by volume)	Not specified	0.4 ppm (max.)

TABLE C-5 Cylinder Data

STANDARD FEDERAL CYLINDERS

Gas	Capacity (cu. ft.)	Full Cylinder Pressure at 70°F (psig)	Height excl. cap (in.)	Nominal Circumference (in.)	Federal Stock Number 8120-00
Air	200	1,800	51	28-1/4 ± 13/16	151-9745
Air	250	2,265	51 ± 1/4	28-1/4 ± 13/16	577-4108
Helium	217	2,265	51 ± 1	28-1/4 ± 13/16	244-6981
Hydrogen	176	1,800	51 ± 1/2	28-1/4 ± 13/16	151-9754
Nitrogen	184	1,800	51 ± 1/2	28-1/4 ± 13/16	151-9759
Oxygen	200	1,800	51	28-1/4 ± 13/16	151-9758

STANDARD INDUSTRIAL CYLINDERS

Gas	Capacity (cu. ft.)	Full Cylinder Pressure at 70°F (psig)	Height incl. cap (in.)	Nominal Circumference (in.)	Water Volume (cu. in.)
Air	229	2,200	56	28-9/32	2,640
Air	305	2,640	60	29-1/16	3,000
Helium	286	2,640	60	29-1/16	3,000
Nitrogen	224	2,200	56	28-9/32	2,640
Oxygen	244	2,200	56	28-9/32	2,640
Oxygen	330	2,640	60	29-1/16	3,000
Oxygen	150	2,200	51	23-3/16	1,630

Mixing Procedures C.2

Two or more pure gases, or gas mixtures, may be combined by a variety of techniques to form a final mixture of predetermined composition. The techniques for mixing gases, in the order of their frequency of use in the U. S. Navy, are—

Mixing by partial pressure—based on the fact that the proportion by volume of each gas in a mixture is in direct relation to its partial pressure.

Continuous-flow mixing—in which a pre-calibrated mixing system proportions the amounts of each gas in a mixture by controlling the flow of each gas as it is delivered to a common mixing chamber.

Mixing by volume—whereby known volumes of each gas are delivered to a constant-pressure gas holder at near-atmospheric pressure, and the final mixture is subsequently compressed into high-pressure cylinders.

Mixing by weight—most often employed where small, portable cylinders are used, proportions the gases in the final mixture by the weight that each gas adds to the initial weight of the container.

Aboard ships, where space is limited and motion might affect the accuracy of precision scales, gases are normally mixed by partial pressure or by continuous-flow mixing systems. The latter two techniques, respectively, require large, gas-tight holding tanks and extremely accurate scales, and, consequently, are most suitable for use in shore-based facilities.

Mixing by Partial Pressure

The method of mixing gases in proportion to their partial pressures in the final mixture is commonly used at most Navy facilities. The basic principle behind this method is Dalton's Law of Partial Pressures (Chapter Two, Volume 1), which states that the total pressure of a mixture is equal to the sum of the partial pressures of all the gases in the mixture.

Two methods are available to calculate the partial pressure of a gas in a mixture; the ideal- (or perfect) gas method and the real-gas method. The ideal-gas method assumes that pressure is directly proportional to the temperature and density of a gas. The real-gas

method additionally accounts for the fact that certain gases will compress more or less than other gases.

Compressibility is a physical property of every gas. Helium does not compress as much as oxygen. If two cylinders with the same internal volume are filled to the same pressure, one with oxygen and the other with helium, the oxygen cylinder will hold more cubic feet of gas than the helium cylinder. As pressure is increased, and/or as temperature is decreased, the difference in the amount of gas in each cylinder will increase. The same phenomenon results when two gases are mixed together in one cylinder. If an empty cylinder is filled to 1000 psia with oxygen and then topped off to 2000 psia with helium, the resulting mixture will contain more oxygen than helium.

An awareness of the differences in the compressibility of various gases is usually sufficient to avoid the problems which are often encountered when mixing gases. When using the ideal-gas procedures which follow, a knowledgeable diver will add less oxygen than is called for, analyze the resulting mixture and compensate as necessary. As an alternate, the U. S. Navy Diving Gas Manual (NAVSHIPS 0994-003-7010, June 1971) may be consulted for procedures to accurately calculate the partial pressures of each gas in the final mixture. These procedures take into account the compressibility of the gases being mixed. Regardless of the basis of the calculations used to determine the final partial pressures of the constituent gases, the mixture must always be analyzed for oxygen content prior to use.

A. Single Cylinder Mixing Procedure—Ideal-Gas Method—When small quantities of a gas mixture are needed, it may be prepared using one cylinder at a time. The equipment needed consists of a partially filled cylinder of inert gas, a high pressure oxygen cylinder, a two-cylinder mixing manifold (Figure C-1) and an oxygen analyzer.

1. Measure the pressure in the inert-gas cylinder, P_i .
2. Calculate the pressure in the inert-gas cylinder after mixing, using the following equation—

$$P_F = \frac{P_i + 14.7}{A} - 14.7$$

Where,

- P_f = final cylinder pressure, psig*.
- P_i = inert gas cylinder pressure (psig).
- A = decimal percent of inert gas in the final mixture.

* P_f cannot exceed the working pressure of the inert-gas cylinder.

3. Measure the pressure in the oxygen cylinder, P_o .
4. Determine if there is sufficient pressure in the oxygen cylinder to accomplish mixing without the need of an oxygen transfer pump—

$$P_o \geq 2(P_f - P_i) + 50$$

Where,

- P_o = pressure in the oxygen cylinder, psig
- 50 = required minimum overpressure, psi
- \geq means greater than or equal

5. Connect the inert-gas and oxygen cylinder together using the two-cylinder mixing manifold as shown in Figure C-1.
6. Open the inert-gas cylinder valve.
7. Crack open the oxygen cylinder valve and bleed oxygen into the inert-gas cylinder at a maximum rate of 70 psi per minute until the desired P_f is reached.
8. Close the oxygen cylinder valve. The heat of compression will have caused the inert-gas cylinder to increase in temperature and give a false indication of the pressure in the cylinder. The calculation requires that P_f be taken at the same temperature as P_i . However, because of the compressibility effects previously discussed, more

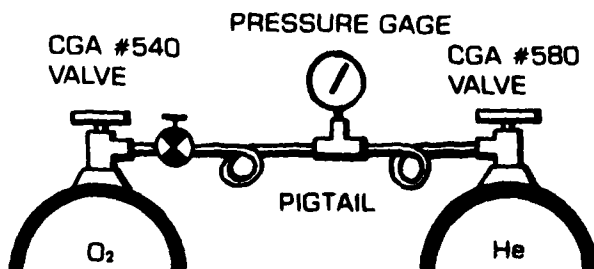

Figure C-1 Two-cylinder mixing manifold

oxygen will normally have been bled into the inert-gas cylinder than expected. Therefore; allow the cylinder to stand for at least 6 hours to permit the gases to mix homogeneously, or, if equipment is available, roll the cylinder for at least one hour. Analyze the gas mixture to determine its oxygen percentage. It should be near or slightly below the desired percentage.

9. Add oxygen as judged necessary, roll the cylinder and re-analyze the mixture. Repeat this procedure as required until the desired mixture is attained.

B. Multiple-Cylinder Mixing Procedure—Ideal-Gas Method—If large amounts of mixed gas are required, two or more cylinders may be prepared using the multiple-cylinder mixing procedure. The equipment needed to conduct this operation consists of a number of inert-gas cylinders equal to the number of mixed-gas cylinders required, an equal number of high pressure oxygen cylinders, a manifold arrangement as illustrated in Figure C-2 and an oxygen analyzer.

1. Connect up a multiple-cylinder mixing manifold as shown in Figure C-2. Close all valves.
2. Open all the cylinder valves.
3. Crack valve A to equalize the pressure in all the oxygen cylinders.
4. Crack valve B to "split" the inert gas.
5. Read the equalized pressure in the inert-gas cylinders (P_i).
6. Calculate the pressure in the inert-gas cylinders after mixing (P_f).

$$P_f = \frac{P_i + 14.7}{\text{Decimal percent helium in final mixture}} - 14.7$$

7. Read the equalized pressure in the oxygen cylinders (P_o).
8. Determine if there is sufficient pressure in the oxygen cylinders to accomplish mixing.
 $P_o \geq 2(P_f - P_i) + 50$
9. Crack valve C (and valve D if two operators are available) and bleed oxygen into the inert-gas cylinders at a rate not to exceed 70 psi per minute, until the desired P_f is reached.

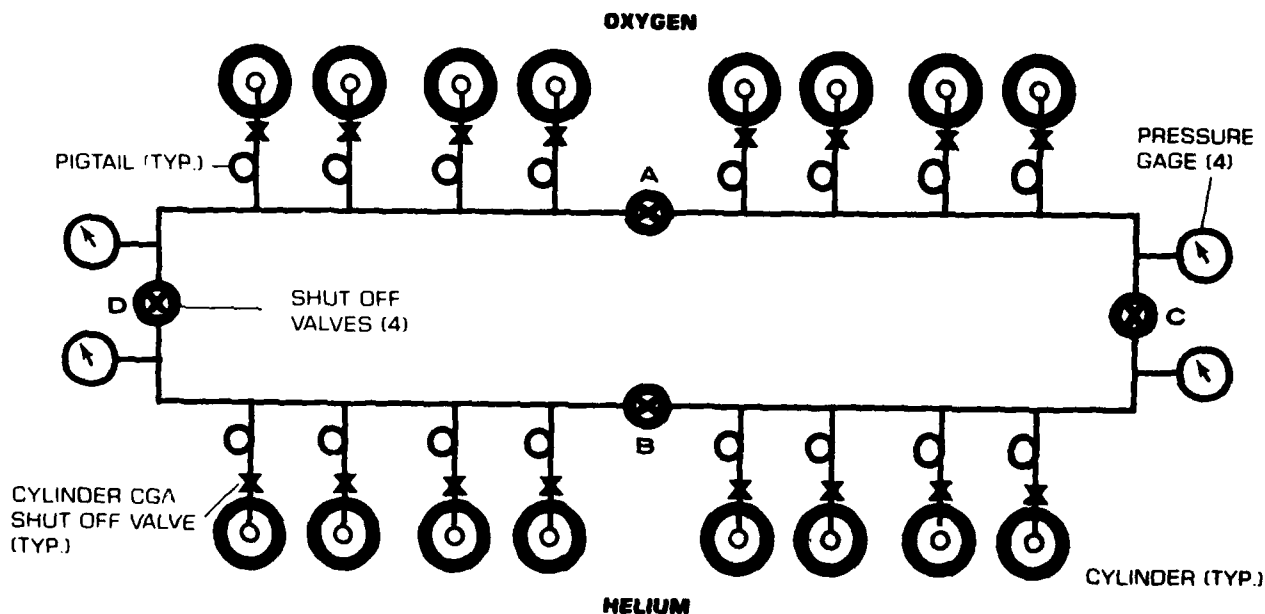

Figure C-2 Multiple-cylinder mixing manifold

10. Close valves C (and D) and allow the mixed-gas cylinders to stand for at least 6 hours to permit homogeneous mixing. As mentioned in the single-cylinder mixing procedures, the temperature effect will approximately compensate for the compressibility effects.
11. Analyze the oxygen percentage of the mixture.
12. Add oxygen as judged necessary, allow adequate mixing and re-analyze the mixture. Repeat this procedure until the desired mixture is attained.
4. Divide the existing helium pressure (step 2.) by the desired helium percentage (step 3.) in decimal form. (This step yields the cylinder pressure that will exist when enough oxygen has been added to yield the desired percentage.)
5. Add oxygen until this pressure is reached. (Allow temperature and pressure to stabilize and add more oxygen if necessary.)
6. The following formula sums up the computation:

C. Adjustment of Percentage

If it is necessary to increase the oxygen percentage of a previously mixed cylinder, follow these steps:

1. Subtract the known percentage of oxygen from 100 to obtain the existing percentage of helium.
2. Multiply the helium percentage by the cylinder pressure to obtain the pressure of helium in the cylinder.
3. Subtract the desired oxygen percentage from 100 to obtain the desired percentage of helium.

$$F = \frac{PX(1.00 - O_o)}{(1.00 - O_f)}$$

where

- F = final cylinder pressure
- P = original cylinder pressure
- O_o = original oxygen percentage (decimal form)
- O_f = final oxygen percentage (decimal form)

7. Example:

For a cylinder containing 1,000 psi of a 16-percent-oxygen mixture, with a 20-percent-oxygen mixture desired

$$F = \frac{1,000 \times (1.00 - 0.16)}{1.00 - 0.20} = \frac{1,000 \times 0.84}{0.80}$$
$$= \frac{840}{0.80} = 1,050 \text{ psi}$$

Therefore, add 50 psi of oxygen to obtain a cylinder pressure of 1,050 psi.

To reduce the oxygen percentage, use this procedure:

1. Multiply oxygen percentage (decimal form) by the cylinder pressure to obtain psi of oxygen pressure.
2. Divide this figure by the desired oxygen percentage (decimal form). This yields the final pressure to be obtained by adding helium.
3. Formula (symbols as in (C) above):

$$F = \frac{PX_{O_2}}{Of}$$

4. Example:

For a cylinder containing 1,000 psi of a 20-percent-oxygen mixture, with a 16-percent-oxygen mixture desired

$$F = \frac{1,000 \times 0.20}{0.16} = \frac{200}{0.16} = 1,250 \text{ psi}$$

Therefore, add 250 psi of helium to obtain a cylinder pressure of 1,250 psi.

The above mixing procedures also apply to mixing by means of the oxygen-transfer pump. Instead of being bled directly from an oxygen cylinder into a helium cylinder, oxygen may be drawn from a cylinder at low pressure by the oxygen-transfer pump and discharged into the helium cylinder until the proper cylinder pressure is reached. This allows the use of most of the oxygen in the cylinder and is therefore more conservative in gas usage.

Continuous-Flow Mixing

Continuous-flow gas mixing systems perform a series of functions which ensure extremely accurate mixtures. Constituent gases are regulated to the same pressure and temperature before they are metered through precision micro-metering valves. The valve settings are pre-calibrated and displayed on curves, provided with every system, which relate final mixture percentages with valve settings. After mixing, the mixture is analyzed on-line to provide a continuous history of the oxygen percentage. Many systems have feedback controls which automatically adjust the valve settings when the oxygen percentage of the mixture varies from pre-set tolerance limits. The final mixture may be supplied directly to a diver or chamber or, alternately, compressed into storage tanks for later use.

Mixing By Volume

Mixing by volume requires accurate gas meters to measure the volume of each gas added to the mixture. When preparing mixtures using this technique, the gases being mixed must be at the same temperature unless the gas meters are temperature compensated.

The volumes of each of the constituent gases are calculated, based on their desired percentages in the final mixture. For example, if 1000 standard cubic feet of a 90% helium-10% oxygen mixture is needed, 900 standard cubic feet of helium will be added to 100 standard cubic feet of oxygen. Normally, an inflatable bag, large enough to contain the required volume of gas at near atmospheric pressure, is used as the mixing chamber. The pure gases, which are initially contained in high pressure cylinders, are regulated to atmospheric pressure, metered and piped into the mixing chamber. Finally, the mixture is compressed and stored in high pressure flasks or cylinders.

Extremely accurate mixtures are possible using the volume technique of mixing, providing that the temperatures of the constituent gases are essentially the same. Additionally, care must be taken to ensure that the mixing chamber is either completely empty or filled with a known mixture of uncontaminated gas prior to mixing.

Mixing By Weight

If mixing by weight, the empty weight of the container must be known, as well as the weight of any gases inside the container before mixing. The weight of each gas to be added to the container must then be calculated using the procedures described in the U. S. Navy Diving Gas Manual. Although the accuracy of the mixture when using this technique is not affected by variations in gas temperature, it is directly dependent on the accuracy of the scale being used to weigh the gases. This accuracy should be known and the operator must be aware of its affect on the accuracy of the composition of the final mixture. As a safeguard, the final mixture must be analyzed for composition using a suitably accurate method of analysis.

Gas Analysis C.3

The precise determination of the type and concentration of the constituents of breathing gas is of vital importance in many diving operations. As has been shown in Chapters Three and Nine of this manual, adverse physiological reactions can occur whenever exposure time and concentrations of various components in the breathing atmosphere vary from prescribed limits.

Concern for the quality of the breathing gas is important in both air and mixed-gas diving. In air diving, because basic gas composition is fixed, primary consideration is directed toward determination of gaseous impurities that may be present in the air supply (carbon monoxide, hydrocarbons) and the effects of inadequate ventilation (carbon dioxide). The use of analytical equipment in air diving, however, is not routine practice; it is generally employed only when improper functioning of the air supply is suspected or in the evaluation of new equipment.

The use of gas analysis in mixed-gas diving is essential. Because of the potential hazards presented by anoxia, CNS and pulmonary oxygen toxicity, it is mandatory that the oxygen content of the gas supply be determined before a dive. Oxygen analysis is the most common, but not the only type of analytical measurement that is performed in mixed-gas diving. In deep diving systems, the performance of scrubbing equipment must be monitored by carbon dioxide analysis

of the atmosphere. Long-term maintenance of personnel under hyperbaric conditions often necessitates the use of a range of analytical procedures. Analyses are required to determine the presence and concentration of minor quantities of potentially toxic impurities resulting from the off-gassing of materials, metabolic processes, and other sources.

Selection of an instrument for analyzing hyperbaric atmospheric constituents must be determined on an individual, on-land basis. Two characteristics of particular importance are—accuracy and response time. Accuracy within the range of expected concentration must be adequate to determine the true value of the constituent being studied. This characteristic is of particular importance when a sample must be taken at elevated pressure and expanded to permit analysis. Response time of the instrument to changes in constituents which may rapidly change and result in quick development of toxic conditions.

Response times of up to 10 seconds are adequate for monitoring gas concentrations such as oxygen and carbon dioxide in a diving apparatus. When used for monitoring hyperbaric chamber atmospheres, response times of up to 30 seconds are acceptable. Proper determination of accuracy obeys no hard and fast rule; but, in general, an instrument should be able to accurately measure concentrations to within $\pm 1/10$ of the maximum allowable concentration. Thus, if one wishes to analyze for carbon dioxide with a maximum permissible concentration of 5,000 ppm (SEV), an instrument with an accuracy of at least ± 500 ppm (SEV) must be used.

Besides accuracy and response time, portability may play a factor in choosing the correct instrument. While large, permanently mounted instruments are acceptable for installation on fixed chamber facilities, small hand-carried instruments are better suited for emergency use inside a chamber or for use at remote dive sites.

The constituents of a gas may be analyzed both qualitatively (type determination) and quantitatively (type and amount) using many different techniques. Although each technique will not be discussed, the major

types are listed below as a reference for the reader who desires to study them in detail—

Mass Spectrometry
Colorimetric Detection
Ultraviolet Spectrophotometry
Infrared Spectrophotometry
Gas Chromatography
Electrolysis
Paramagnetism

Rapidly changing technology makes it impractical to list all the types of instruments currently available. Guidance regarding instrument selection can readily be obtained from Navy units operating saturation diving complexes or from instrument manufacturer technical representatives.

Safe Handling Rules for Compressed Gas Containers (in general use) C.4

Content identification—Each cylinder must bear the proper DOT label or alternative marking required for the compressed gas contained. Content identification must be applied before filling, or before removal from the filling manifold or, when mixtures are analyzed. Content identification may be applied after filling and analyzing, and must be present during transportation and delivery to the user.

Transfilling—Compressed gases should not be transferred from one container to another container except by a gas manufacturer, a gas distributor who compresses gases into containers by compressors or pumps, or a trained and qualified person.

Gas mixtures—Compressed-gas containers must not contain gases capable of combining chemically with each other or with the container material so as to endanger its integrity.

Changing gas service—The gas service shall not be changed without first removing the original content, and if residues are present, cleaning and purging.

Maintenance

Authorization—Containers and their appurtenances shall be maintained only by the container owner or his authorized representative.

Changing prescribed markings—The prescribed markings stamped into containers shall not be removed or changed without authority from the Bureau of Explosives.

Changing content markings—The user shall not deface or remove any markings, labels, decals, tags or stencil marks applied by the supplier and used for identification of content.

Pressure-relief devices—The user shall not change, modify, tamper with, obstruct or repair the pressure-relief devices in container valves or in containers.

Containers or appurtenances—The user shall not repair or alter containers or container valves.

Painting

User—The user shall not paint containers unless authorized by the owner.

Container color—Containers may be painted by the gas suppliers to permit the suppliers to help recognize their containers and to segregate them more readily in their handling operations. Color shall not be used to identify container content.

Contamination—The user shall notify the owner or supplier of the container if any condition has occurred which might permit any harmful foreign substance to enter the container or valve giving details and container serial number.

Fire-burned containers—Compressed-gas containers that have been exposed to fires shall not be shipped if they still contain compressed gas. Consult the gas supplier under these circumstances.

Corroded containers and valves—When containers or valves are severely corroded, the supplier shall be notified and his instructions followed.

Other container damage—Any other damage noted that might impair the safety of the container shall be called to the attention of the gas supplier before the return of the container.

Container Usage

Content identification—Where the user is responsible for the handling of the container and connecting it for use, such containers shall carry a legible label or marking identifying the content. Refer to American National Standard Method of Marking Portable Compressed Gas Containers to Identify the Material Contained Z48.1, and CGA Pamphlet C-7 "Guide to the Preparation of Precautionary Labeling and Marking of Compressed Gas Containers." Containers not bearing a legible label identifying the contents shall not be used and shall be returned to the gas supplier.

Cylinder caps—Where removable caps are provided by the gas supplier for valve protection, the user shall keep such caps on containers at all times except when containers are connected to dispensing equipment.

Misuse—Containers shall not be used as rollers, supports or for any purpose other than to contain the content as received.

Containers not in use—The user shall keep container valves closed at all times (charged or empty) except when the container is in use. By "in use" it is meant when gas is flowing from the container, when the container gas is maintaining pressure in a supply line, or when the container is standing by during and between operations utilizing the gas.

Electrical circuits—Containers shall not be placed where they might become part of an electrical circuit. When the containers are used in conjunction with electric welding, compressed-gas containers shall not be grounded. These precautions will prevent burning by electric welding arc.

High temperature—Compressed-gas containers shall not be subjected to an atmospheric temperature above 130°F. A flame shall never be permitted to come in contact with any part of a compressed-gas container. If ice or snow accumulate on a container, thaw at room temperature, or thaw with water at temperature not exceeding 130°F.

Low temperature—Containers shall not be subjected to artificially created low temperatures without approval of the supplier. Many steels undergo significantly decreased impact resistance and ductility at low temperatures. The use of containers at extremely low ambient temperatures shall require the use of check valves to prevent back flow due to the low vapor pressure of the liquified gas.

Leaking containers—If a container leaks, and the leak cannot be remedied by tightening a valve gland or packing nut, the valve shall be closed, and a tag attached stating that the container is unserviceable. If the gas is flammable, keep away from ignition sources. Remove the leaking container outdoors to a well ventilated location, or place under an exhaust ventilating system suitable for the product. If the gas is flammable or toxic, place an appropriate sign at the container warning against these hazards. The gas supplier shall be notified and his instructions followed as to the return or disposition of the container.

Returning empty containers—Before returning empty containers, the valve shall be closed and container valve protection caps, if used, shall be replaced. Cylinders equipped with valve-outlet caps or plugs, or sealing valve caps shall be returned with these caps or plugs in a gas-tight condition. Empty containers shall be labeled or marked according to DOT Regulations.

Moving Containers

Trucks—Containers shall not be dragged or slid. Where practical, the user should use a suitable hand truck, fork truck, roll platform or similar device with container secured for transporting.

Rough handling—Containers shall not be dropped or permitted to strike against each other or other surfaces violently.

Lifting

Caps—shall not be used for lifting containers except for the use of hand trucks which grip the cylinder cap for lifting on to the hand truck. (This shall not be

interpreted to prohibit cylinders with caps from being suspended during cylinder manufacturing operations, or tilting cylinders to an upright position.)

Magnets—shall not be used for lifting containers.

Ropes, chains or slings—shall not be used to suspend containers unless provisions at time of manufacture have been made on the container for appropriate lifting attachments, such as lugs.

Cradles or platforms—where appropriate lifting attachments have not been provided on the container, suitable cradles or platforms to hold the containers shall be used for lifting.

Storing Containers

Regulations—Containers shall be stored in accordance with all state and local regulations and in accordance with appropriate standards of the Occupational Safety and Health Administration, the Compressed Gas Association and the National Fire Protection Association.

Posting—Container storage areas in users' facilities shall be prominently posted with the name of the gases to be stored.

Grouping—Where gases of different types are stored at the same location, containers should be grouped by types of gas, and the groups arranged to take into account the gases contained. Full and empty containers should be stored separately with the storage layout so planned that containers comprising old stock can be removed first with a minimum handling of other containers.

Storage rooms—Storage rooms shall be well ventilated and dry. Where practicable, storage rooms should be of fire-resistive construction.

Separation from combustibles—Containers shall not be stored near readily ignitable substances such as gasoline or waste, or near combustibles in bulk, including oil.

External corrosion—Containers should not be exposed to continuous dampness and should not be stored near salt or other corrosive chemicals or fumes. Corrosion may damage the containers and may cause the valve protection caps to stick.

Mechanical damage—Containers shall be protected from any object that will produce a harmful cut or other abrasion in the surface of the metal. Containers shall not be stored near elevators, gangways, unprotected platform edges or in locations where heavy moving objects may strike or fall on them.

Containers standing upright—The user shall store containers standing upright where they are not likely to be knocked over, or containers shall be secured in an upright or in a horizontal position.

Outdoor storage—Containers may be stored in the open but should be protected from the ground beneath to prevent bottom corrosion. Containers may be stored in the sun except in localities where extreme temperatures prevail. If the supplier recommends storage in the shade for a particular gas, such recommendation shall be observed.

Public areas—Containers in public areas should be protected against tampering.

Interference with egress—Containers when stored inside shall not be located near exits, stairways, or in areas normally used or intended for the safe exit of people.

Secure containers—The user shall secure containers while connected to a portable welding, cutting, brazing or heating appliance or other portable utilization equipment to prevent them from being knocked over.

Pressure regulator—A suitable pressure-regulating device shall be used where gas is admitted to a system of lower pressure rating than the supply pressure, and where, due to the gas capacity of the supply source, the system pressure rating may be exceeded.

NOTE: This is a requirement regardless of the possible pressure-relief device protecting the system.

System pressure-relief device—A suitable pressure-relief device shall be used to protect a system utilizing a compressed gas where the system has a pressure rating less than the compressed-gas supply source and where, due to the gas capacity of the supply source, the system pressure rating may be exceeded.

Connections—Connections that do not fit shall not be forced. Threads on regulator connections or other auxiliary equipment shall match those on container valve outlet. Detailed, dimensioned drawings of standard container valve outlet and inlet connections are published in the "American National and Canadian Standard Compressed Gas Cylinder Valve Outlet and Inlet Connections." (ANSI-B57.1 and CSA-B96)

Manifold—Where compressed-gas containers are connected to a manifold, such a manifold and its related equipment, such as regulators, shall be of proper design.

Changing service—Regulators, gages, hoses and other appliances provided for use with a particular gas or group of gases shall not be used on containers containing gases having different chemical properties unless information obtained from the supplier indicates that this can be done safely. As an example, only pressure-regulating devices approved for use with oxygen shall be used in oxygen service.

Container valve—Container valve shall be opened slowly. Valve outlets shall be pointed away from yourself and other persons. On valves without handwheels, the wrenches provided by, or recommended by, the gas supplier shall be used. On valves with hand wheels, wrenches shall not be used except when designed specifically for that purpose. Valve wheels shall not be hammered in attempting to open or close the valve. For valves that are hard to open, or frozen because of corrosion, the supplier shall be contacted for instructions.

Dusting clothing—Compressed gas shall not be used to dust off clothing. This may cause serious injury to the eyes or body, or create a fire hazard.

Check valves—Compressed gases shall not be used where the container may be contaminated by the feedback of process materials unless protected by suitable traps or check valves.

Gas tightness—Connections to piping, regulators, and other appliances shall be kept tight to prevent leakage. Where hose is used, it shall be kept in good condition.

Removing pressure regulator—Before a regulator is removed from a container, the container valve shall be closed and the regulator drained of gas pressure.

Oxygen (Including Oxidizing Gases)

Cleanliness—Oxygen containers, valves, regulators, hoses and other oxygen apparatus shall be kept free from oil or grease and shall not be handled with oily hands, oily gloves, or with greasy equipment.

Separation of oxygen from combustibles—Oxygen containers in storage shall be separated from flammable-gas containers or combustible materials (especially oil or grease) a minimum distance of 20 feet or more by a noncombustible barrier at least 5 feet high, having a fire-resistance rating of at least one-half hour.

Capacity limitations—An oxygen manifold or oxygen bulk storage system at consumer sites and which has storage capacity of more than 20,000 cubic feet of oxygen (measured at 14.7 psia at 70°F) including unconnected reserves at the site, shall comply with the provisions of the Standard for Bulk Oxygen Systems at Consumer Sites, NFPA No. 50.

Oxygen-enriched atmosphere—The oxygen concentration in work areas, other than in hyperbaric chambers, shall not exceed 23 percent by volume.

APPENDIX D

SURFACE-SUPPLIED MIXED-GAS DIVING OPERATIONS—PRE-DIVE CHECKLIST

MK 5 Diving Outfit D.1 Diving Equipment Preparation

1. Assemble and lay out all equipment that may be used in the dive—including primary gear, standby gear, accessories tools and spares.
2. Carefully inspect all equipment for signs of wear, distortion, cracks or tears, rot, corrosion, and dirt. Clean and repair as necessary, or discard and replace.
3. Specifically check the following items—
 - A Examine the faceplate rubber gasket for wear.
 - B Examine the glass in the faceplate and ports for cracks or inadequate seal.
 - C Check the interior of the helmet to ensure that all portions are dry and free of verdigris and dirt. Check the terminals of the diver's communication system.
 - D Check the threads on the goosenecks for damage, verdigris or wear.
 - E Ensure that the safety lock (dumbbell) moves freely, and that the safety latch on the breastplate has a brass cotter pin.
 - F Check that the breastplate studs are free of distortion or thread damage.
 - G Check serial numbers on the breastplate straps to verify that they are the correct set for the breastplate.
 - H Verify the presence of four copper washers and twelve wing nuts (four of which should be flanged and one of which is of a special design to accommodate the control valve/Hoke valve assembly).
 - I Check the operation (by smoke test) of the non-return valve.
 - J Check the packing on the control valve; verify the presence of the cotter key.
 - K Check the freedom of movement of the exhaust valve handwheel and chin button.
 - L Check the secondary exhaust valve. The rubber diaphragms should be supple, clean, and free from cracking.
 - M Check all Koroseal or neoprene washers; clean with fresh water. In cold weather operations pre-warm washers in warm fresh water before use.
 - N Check and clean aspirator screen; replace if defective or corroded.
 - O Check all connections on the hose leading from the Hoke needle valve (at the control valve unit) to the venturi.

4. Check the following general equipment—

- A Check that all needed accessory equipment, tools, lights, special systems, spares, etc., are on scene and in order. In testing lights, all tests should be conducted with the lights submerged in water and extinguished before removal to prevent overheating and failure.
- B Erect the diving (decompression) stage or attach the diving ladder. Make up and place the decompression line. In the case of the stage, be careful to ensure that the shackle connecting the stage line is securely fastened.
- C Place the gas hose bulwark roller in place at the rail.

Mixed-Gas Supply Preparation

1. Check the primary and standby system to verify that a mixed-gas breathing supply is available with capacity and supply pressure to completely service all divers and accessory equipment throughout all phases of the planned operation. Supply pressure must be capable of supporting continual 100 psi overbottom pressure at the operating depth.
2. Check that the standby air supply system (which may be used as a backup for emergencies and for the recompression chamber) is fully operational. A checklist concerning air supply systems can be found in Chapter Six, Volume 1.
3. The Mixed-Gas Supply System check should include—
 - A Have the required number of HeO₂ and O₂ cylinders on hand to supply the gas required for the operation. (Check and handle cylinders in accordance with Cylinder Handling Rules found in Appendix C.)
 - B Verify pressure and content (gas mixture) of all cylinders.
 - C Verify that extra, filled O₂ cylinders are located in the rack area in case of emergency requirements. (Observe all safety rules regarding storage and use of oxygen.)
 - D Install all HeO₂ and O₂ cylinders in supply banks. Connect manifolding, piping, and gaging systems.
 - E Ensure that all connections and fittings are free of any trace of oil or grease.

F Check that all filters, cleaners, and oil separators are clean and properly installed.

G Bleed off all condensed moisture from manifolds, lines, filters, and the bottom of volume tanks (accumulators). Ensure all drain plugs are properly re-tightened.

H Check that all petcocks are in the closed position.

I Check all pressure-relief valves, regulators, and unloaders. Ensure that all unloaders are in the compressed position.

J Hook up all connections between the supply bank, volume tanks, and supply hoses leading to helmets or open bell.

K Check the line of supply both through the volume tanks and through the bypass system for direct supply.

L Rig a fresh water line to the diving station for use in washing out canisters.

M Rig an air line to the diving station for use in blowing out canisters.

N Verify that all supply hoses running to and from supply points have proper leads. Do not pass hoses near high-heat areas such as steam lines. Ensure that hoses are free from kinks and bends, and are not exposed on deck in such a way that they could be rolled over, damaged, or severed by machinery or other activities.

Verify hoses on all systems

—Primary Mixed Gas

—Secondary Mixed Gas

—Standby Air

O Check "Do Not Touch — Diver's Breathing Supply" tags on all lines, controls, and valves as required.

Air Supply Activation

1. Open bank valves and check the pressures at the gages.

2. Activate system, working from banks, to volume tanks, to control rack, to diving station. Check all bypasses, regulators, dome loaders, and gages.

3. Check that the control rack can deliver both the primary and secondary supplies of mixed-gas, standby air, and pure O₂. This supply must be available to—

—Divers

—Diving station

—Recompression chamber

—Accessory operation lines

4. Check all fittings, hoses, piping, valves, etc., by soap testing, with pressure on.

5. Test the recompression chamber.

6. Test the chamber O₂ system.

Hose Inspection

1. Verify that no hose exceeds 3 years in age from the date of manufacture.

2. Check that the newest (or best) hose length is the section nearest to the surface, since that is the region where the hose will be subject of the greatest pressure differential.

3. Check that hoses are free of moisture, packing material, and chalk.

4. Soap test all hose connections after they have been hooked up to the activated gas supply.

5. Open control valve, close Hoke valve, and check for leaks. Soap test.

6. Open control valve and Hoke valve and test helmet connections for leaks.

7. Set exhaust valve. Fully close and then back off 2½ turns.

Recompression Chamber Check-Out

1. Check that the chamber is completely free of all combustible materials. Ensure no unauthorized items (such as trash, matches, rags, etc.) are in the chamber.

2. Check that the primary and back-up supply is hooked up to the chamber and all pressure gages. Verify the supply of He₂, O₂, and air.

3. Check that the chamber is free of all odors or other contaminants.

4. Verify the presence of an approved fire extinguishing device in the chamber.

5. If blankets are to be placed in the chamber, they must be of the prescribed nonflammable type procured through the Navy supply system.

6. Verify that the medical kit is completely outfitted and in the chamber.

7. Verify that a suitable number of O₂ breathing masks are present in the chamber. There should be enough for at least two divers, a tender, and medical personnel.

8. Check all doors and seals.

Final Preparations

1. Verify that all necessary records, logs, and time-sheets are on the diving station.
2. Check that the appropriate and most up-to-date decompression tables are on hand, together with personnel trained in their use. Be sure that the decompression program has been pre-planned, and the diving team briefed.
3. Verify that all gas supply systems have a volume tank or accumulator installed in the supply system between the supply source and the diver's hose connection or bell. Verify that the standby air system conforms to the checklist in Chapter Six, Volume 1.
4. If possible, an extra mask and hose should be rigged to the air supply source. Note: Many Navy diving operations have a lightweight mask rigged for standby use even when conducting mixed-gas deep sea operations. This is done in the event a standby diver must enter the water and assist a diver on or near the surface.
5. Check the source and supply of CO₂ absorbent. Break out the appropriate amount of absorbent for the dive.
6. Set up special canister filling racks.
7. Place the dressing bench in position, ensuring that the diver does not have a long way to travel to reach the diving ladder or stage.
8. Rig a small block and tackle (jigger) over the dressing bench. The diver should be fully dressed on the dressing bench and then moved to the stage.
9. Make a final check of all descending, stage, and decompression marker lines.

Immediately Prior to Start of Diving

1. Dependent upon depth, verify that a diving medical officer and a recompression chamber are present on the diving station.
2. Check the moor; verify the position of the vessel and that it is in a secure two or four-point moor.
3. Take accurate depth soundings, using two methods.
4. Determine that all valves, switches, and controls that can influence the diving operation are properly tagged to prevent inadvertent activation or shut-down.
5. In particular, verify that all components of the diver's gas supply are properly marked to prevent un-

authorized or untrained personnel from cycling these components.

6. Verify that signals indicating that diving operations are being conducted are properly displayed.
7. Make certain that all personnel who can in any way influence the conduct of the operation have been informed that diving operations are about to commence.
8. Do not start diving until final permission has been given by the OOD acting for the commanding officer.

MK 1 Diving Outfit

D.2

Diving Equipment Preparation

1. Assemble and lay out all equipment that may be used in the dive—including primary gear, standby gear, accessories, tools, and spares.
2. Carefully inspect all equipment for signs of wear, distortion, cracks or tears, rot, corrosion, and dirt. Clean and repair as necessary or discard and replace.
3. Check the following items—
 - A Check the lightweight diving suit for rips or excessive wear.
 - B Check the vest for correct number of weights, as well as for wear.
 - C Check the MK 1 mask for cracks, breaks, or improper assembly.
 - D Check the faceplate and seal.
 - E Check that the face and oral-nasal mask are properly attached to the main mask body.
 - F Check that all metal components are properly secured to the fiberglass body.
 - G Check for any loose mounting bolts, or any visible dents or damage.
 - H Check that the nose clearing device slides in and out easily.
 - I Check the head spider for wear.
 - J Gage the emergency gas supply cylinder. Confirm gas mixture.
 - K Check all other accessory equipment according to the SCUBA equipment checklist in Chapter Five of Volume 1.
4. Check the following general equipment—
 - A Check that all needed accessory equipment, tools, lights, special systems, spares, etc., are on scene

and in order. In testing lights, all tests would be conducted with the lights submerged in water and extinguished before removal to prevent overheating and failure.

- B Erect the diving (decompression stage or attach the diving ladder. Make up and place the decompression line. In case of the stage, be careful to ensure that the shackle connecting the stage line is securely fastened.

Mixed-Gas Supply Preparation

1. Check the primary and standby system to verify that a mixed-gas breathing supply is available with a capacity in terms of purity, volume, and supply pressure to completely service all divers and accessory equipment throughout all phases of the planned operation. Supply pressure must be capable of supporting continual 135 psi overbottom pressure at the operating depth.

2. Check that the standby air supply system (which may be used as a backup for emergencies and for the recompression chamber) is fully operational. A checklist concerning air supply systems can be found in Chapter Six, Volume 1.

3. The Mixed-Gas Supply System check should include—

- A Have the required number of HeO₂ and O₂ cylinders on hand to supply the gas required for the operation. (Check and handle cylinders in accordance with Cylinder Handling Rules found in Appendix C, Paragraph C.4)
- B Verify pressure and content (gas mixture) of all cylinders.
- C Verify the extra, filled O₂ cylinders are located in the rack area in case of emergency requirements. (Observe all safety rules regarding storage and use of oxygen.)
- D Install the HeO₂ and O₂ cylinders in supply banks. Connect manifolding, piping, and gaging systems.
- E Ensure that all connections and fittings are free of any trace of oil or grease.
- F Check that all filters, cleaners, and oil separators are clean and properly installed.
- G Bleed off all condensed moisture from manifolds, lines, filters, and volume tanks (accumulators). Ensure all drain plugs are properly re-tightened.

H Check that all petcocks are in the closed positions.

I Check all pressure-relief valves, regulators, and unloaders. Ensure that all unloaders are in the compressed position.

J Hook up all connections between the supply bank, volume tanks, and supply hoses leading to helmets or open bells.

K Check the line of supply both through the volume tanks and through the bypass system for direct supply.

L Verify that all supply hoses running to and from supply points have proper leads. Do not pass hoses near high-heat areas such as steam lines. Ensure that hoses are not exposed on deck in such a way that they could be rolled over, damaged, or severed by machinery or other activities. Verify hoses on all systems.

- Primary Mixed Gas
- Secondary Mixed Gas
- Standby Air
- Hot Water Suit Supply

M Check "Do Not Touch—Diver's Breathing Supply" tags on all lines, controls, and valves as required.

Air Supply Activation

1. Open Bank Valves and check the pressure at the gages.

2. Activate system, working from banks, to volume tanks, to control rack, to diving station. Check all bypasses, regulators, dome loaders and gages.

3. Check that the control rack can deliver both the primary and secondary supplies of mixed-gas, standby air, and pure O₂. This supply must be available to—

- Divers
- Diving Station
- Recompression Chamber
- Accessory Operation Lines

4. Check all fittings, hoses, piping, valves, etc., by soap testing, with pressure on.

5. Test the recompression chamber by blow-down.

6. Test the chamber O₂ system.

Hose Inspection

1. Verify that no hose exceeds 5 years in age from the date of manufacture.

2. Check that the newest (or best) hose length is the section nearest to the surface, since that is the region where the hose will be subjected to the greatest pressure differential.
3. Check that hoses are free of moisture, packing material, and chalk.
4. Soap test all hose connections after they have been hooked up to the activated gas supply.
5. Check that all tie-offs and canvas chaffing over the first length of the hose are in proper condition.

Equipment Test With Activated Gas Supply

1. Hook up all hoses to masks and chambers.
2. Verify both flow and composition of mixed-gas to masks and chambers.
3. Check all nonreturn and control valves.
4. Soap test all connections.

Recompression Chamber Check-Out

1. Check that the chamber is completely free of all combustible materials. Ensure no unauthorized items (such as trash, matches, rags, etc.) are in the chamber.
2. Check that the chamber is free of all odors or other contaminants.
3. Verify the presence of an approved fire extinguishing device in the chamber.
4. If blankets are to be placed in the chamber, they must be of the prescribed nonflammable type procured through the Navy supply system.
5. Verify that the medical kit is completely outfitted and in the chamber.
6. Verify that a suitable number of O₂ breathing masks are present in the chamber. There should be at least enough for two divers, a tender, and medical personnel.
7. Check all doors and seals.

Final Preparations

1. Verify that all necessary records, logs, and time-sheets are on the diving station.
2. Check that the appropriate and most up-to-date decompression tables are on hand, together with personnel trained in their use. Be sure that the decompression program has been preplanned and the diving team briefed.

3. Verify that all gas supply systems have a volume tank or accumulator installed in the supply system between the supply source and the diver's hose connection or bell. Verify that the standby air system conforms to the checklist in Chapter Six, Volume 1.

4. If possible, an extra mask and hose should be rigged to the air supply source. Note: Many Navy diving operations have a lightweight mask rigged for standby use even when conducting mixed-gas operations. This is done in the event a standby diver must enter the water and assist a diver on or near the surface.

5. Place the dressing bench in position, ensuring that the diver does not have a long way to travel to reach the diving ladder or stage.

6. Make a final check of all descending, stage, and open bell lines.

Immediately Prior to Start of Diving

1. When required by depth of operation, verify that a diving medical officer and a recompression chamber are present on the diving station.
2. Check the moor; verify the position of the vessel and that it is in a secure two or four-point moor.
3. Take accurate depth soundings, using two methods.
4. Determine that all valves, switches, and controls that can influence the diving operation are properly tagged to prevent inadvertent activation or shutdown.
5. In particular, verify that all components of the diver's gas supply are properly marked to prevent unauthorized or untrained personnel from cycling these components.
6. Verify that signals indicating that diving operations are being conducted are properly displayed.
7. Make sure that all personnel who can in any way influence the conduct of the operation have been informed that diving operations are about to commence.
8. Do not start diving until final permission has been given by the OOD acting for the commanding officer.

MK 12 Mixed Gas Diving Outfit Diving Equipment Preparation

D.3

1. Assemble all MK 12 SSDS equipment on the diving station, including necessary support equipment such as tools and spare parts.

2. Specifically check the following—

- A Inspect helmet for cracks, breaks, or deep scratches. Select alternate helmet if necessary.
- B Check base for cracks.
- C Visually check for loose, missing, or damaged screws or stripped threads.
- D Inspect viewports for scratches and chips.
- E Check viewport retainers for cracks, warping, broken screws, and stripped threads.
- F Check locking devices to ensure proper operation.
- G Check adjustable exhaust valve. If handle is loose, tighten friction drag screws until desired action is achieved. (Turning motion should be firm but have some resistance.)
- H Check chin button. Motion should be smooth with pressure increasing steadily. Upon release of button, valve should shut with spring tension.
- I Check ambient exhaust valve. Remove cover and inspect body for dirt, corrosion, etc.
- J Check helmet breech ring. Ensure breech ring is free from dents, nicks, and corrosion. Ensure "O" ring groove is clean and free of any foreign substances.
- K Check air supply whip for corrosion or damage. Ensure gasket is clean and in good condition.
- L Check communications whip assembly for cuts, sharp bends, corroded contacts, and damaged threads.
- M Check helmet for internal cleanliness.
- N Check helmet ducting. Ensure proper installation and that assembly is free from dirt, oil, and moisture.
- O Inspect jocking harness hardware for corrosion or damage.
- P Inspect dry suits for tears, punctures, defective seams, and excessive wear.
- Q Inspect neck dam for excessive wear or deterioration.
- R Inspect outer garment for tears, excessive wear, and loose stitching; ensure velcro is in good condition.
- S Inspect tubing in outer garment for proper alignment and connection (if used).
- T Inspect hot water control valve for proper operation (if used).

- U Inspect gloves and boots for excessive wear, tears, or deterioration.
- V Check mixed gas adapters for cleanliness.
- W Inspect and install one-way (Koegel) valves. Ensure proper air flow direction.
- X Ensure helmet liner is not obstructing mixed gas ducting.
- Y Check recirculator canister for cleanliness.
- Z Check recirculator hose connection "O" rings for cleanliness, proper lubrication, location, and/or deterioration.
- AA Ensure that emergency cylinder is fully charged to 2,000 psig.

Mixed-Gas Supply Preparation

1. Check the primary and standby systems to verify that a mixed-gas breathing supply is available with capacity and supply pressure to completely service all divers and ancillary equipment throughout all phases of the planned operation.
2. Check that the standby air supply system (which may be used as a backup for emergencies and for the recompression chamber) is fully operational. A checklist concerning air supply systems can be found in Chapter Six, Volume 1.
3. The Mixed-Gas Supply System check should include—
 - A Have the required number of HeO₂ and O₂ cylinders on hand to supply the gas required for the operation. (Check and handle cylinders in accordance with Cylinder Handling Rules Appendix C, Paragraph C.4)
 - B Verify pressure and content (gas mixture) of all cylinders.
 - C Verify that extra, filled O₂ cylinders are located in the rack area in case of emergency requirements. (Observe all safety rules regarding storage and use of oxygen.)
 - D Install all HeO₂ and O₂ cylinders in supply banks. Connect manifolding, piping, and gaging systems.
 - E Ensure that all connections and fittings are free of any trace of oil or grease.
 - F Check that all filters, cleaners, and oil separators are clean and properly installed.
 - G Bleed off all condensed moisture from manifolds.

lines, filters, and volume tanks (accumulators). Ensure all drain plugs are properly re-tightened.

- H Check that all petcocks are in the closed position.
- I Check all pressure-relief valves, regulators, and unloaders. Ensure that all unloaders are in the compressed position.
- J Hook up all connections between the supply banks, volume tanks, and supply hoses leading to helmets or open bell.
- K Check the line of supply both through the volume tanks and through the bypass system for direct supply.
- L Rig a fresh water line to the diving station for use in washing out canisters.
- M Rig an air line to the diving station for use in blowing out canisters.
- N Verify that all supply hoses running to and from supply points have proper leads. Do not pass hoses near high-heat areas such as steam lines. Ensure that hoses are free from kinks and bends, and are not exposed on deck in such a way that they could be rolled over, damaged, or severed by machinery or other activities.
 - Verify hoses on all systems—
 - Primary Mixed-Gas
 - Secondary Mixed-Gas
 - Standby Air
 - Hot Water Suit Supply
- O Check "Do Not Touch—Diver's Breathing Supply" tags on all lines, controls, and valves as required.

Air Supply Activation

1. Open bank valves and check the pressures at the gages.
2. Activate system, working from banks, to volume tanks, to control rack, to diving station. Check all bypasses, regulators, dome loaders, and gages.
3. Check that the control rack can deliver both the primary and secondary supplies of mixed-gas, standby air, and pure O₂. This supply must be available to:
 - Divers
 - Diving station
 - Recompression chamber
 - Accessory operation lines

4. Check all fittings, hoses, piping, valves, etc., by soap testing with pressure on.
5. Test the recompression chamber by blow-down.
6. Test the chamber O₂ system.

Hose Inspection

1. Ensure that the proper hose length is used, either 200-foot or 600-foot length dependent on the depth of the dive. Verify that no hose exceeds 5 years in age from the date of manufacture.
2. Check that hoses are free of moisture, packing material, and chalk.
3. Soap test all hose connections after they have been hooked up to the activated gas supply.
4. Check that all tie-offs and canvas chaffing over the first 50 feet of hose are in satisfactory condition.

Recompression Chamber Check-Out

1. Check that the chamber is completely free of all combustible materials. Ensure no unauthorized items (such as trash, matches, rags, etc.) are in the chamber.
2. Check that the primary and backup gas supply is hooked up to the chamber and all pressure gages. Verify the supply of HeO₂, O₂, and air.
3. Check that the chamber is free of all odors or other contaminants.
4. Verify the presence of an approved fire extinguishing device in the chamber.
5. If blankets are to be placed in the chamber, they must be of the prescribed nonflammable type procured through the Navy supply system.
6. Verify that the medical kit is completely outfitted and in the chamber.
7. Verify that a suitable number of O₂ breathing masks are present in the chamber. There should be at least enough for two divers, a tender, and medical personnel.
8. Check all doors and seals.

Final Preparations

1. Verify that all necessary records, logs, and time-sheets are on the diving station.
2. Check that the appropriate and most up-to-date decompression tables are on hand, together with personnel trained in their use. Be sure that the decom-

pression program has been preplanned, and the diving team briefed.

3. Verify that all gas supply systems have a volume tank or accumulator installed in the supply system between the supply source and the diver's hose connection or bell. Verify that the standby air system conforms to the checklist in Chapter Six, Volume 1.

4. If possible, an extra mask and hose should be rigged to the air supply source. Note: Many Navy diving operations have a lightweight mask rigged for standby use even when conducting mixed-gas operations. This is done in the event a standby diver must enter the water and assist a diver on or near the surface.

5. Check the source and supply of CO₂ absorbent. Break out the appropriate amount of absorbent for the operation.

6. Place the dressing bench in position, ensuring that the diver does not have a long way to travel to reach the diving ladder or stage.

7. Make a final check of all descending, stage, and decompression marker lines.

Immediately Prior to Start of Diving

1. When required by depth of operation, verify that a diving medical officer and a recompression chamber are present on the diving station.

2. Check the moor; verify the position of the vessel and that it is in a secure two or four-point moor.

3. Take accurate depth soundings, using two methods.

4. Determine that all valves, switches, and controls that can influence the diving operation are properly tagged to prevent inadvertent activation or shut-down.

5. In particular, verify that all components of the diver's gas supply are properly marked to prevent unauthorized or untrained personnel from cycling these components.

6. Verify that signals indicating that diving operations are being conducted are properly displayed.

7. Make certain that all personnel who can in any way influence the conduct of the operation have been informed that diving operations are about to commence.

8. Do not start diving until final permission has been given by the OOD acting for the commanding officer.

INDEX

Absolute Pressure Regulator	11-12, 11-13	Recirculating Helmet	12-3, 12-5
Absorbent, CO ₂ Packing	11-2	Requirements	10-15
Air		Usage	10-15
Compressed		Absorption	
Handling of	C-10	MK 6 MOD 0	11-12, 11-14
Purity Standards	C-1	MK 11 MOD 0	11-18, 11-21
Supply, Activation of	D-2, D-4, D-7	MK 15 MOD 0	11-22, 11-24
Ascent		Oxygen SCUBA	11-22, 14-5
Rate of	17-6	Poisoning, Using UBA	11-3
Schedule, Daily Routine	17-6	Removal	
Aspirator, Recirculating Helmet	12-4	DDC	13-5, 13-6
Assembly of Oxygen SCUBA	14-8	UBA	11-2
ASR He-O ₂ Supply System	10-14, 10-16	Central Nervous System, Oxygen	
Atmosphere Control, Saturation		Poisoning	9-17
Diving	17-3	Chamber	
Automatic Decompression		Fires, Causes of	10-18
Controller, DDS	13-7	Ventilation after Repairs	10-19
Bag Oxygen Percentage	11-5	Channeling of Absorbent	11-3
Bail-Out Bottle	12-14	Chariot Dress	9-2
Bert, Paul	9-3	Charles' Law	9-11
Boiler, Hot Water	12-17	Closed-Circuit	
Bond, George F.	9-7	Oxygen SCUBA	
Bottom Habitats	13-3	Components	14-4
Boyles' Law	9-10	Donning	14-11
Breastplate, Recirculating Helmet	12-3	Flow Schematic	14-3
Breathing		Handling and Assembly	14-8
Bags		Post-Dive Procedures	14-14
Oxygen SCUBA	14-6	Pre-Dive Preparation	14-9
UBA	11-3	Principle of Operation	14-2
Resistance	9-16	Shipment and Storage	14-16
Briefing the Diving Team	10-12	Troubleshooting	14-15
Browne, Jack	9-4	Underwater Procedures	14-14
Bumper Ring, PTC	13-4	Television DDS	13-6
Buoyancy		UBA	
PTC	13-3	Oxygen Analysis and Control	11-9
UBA	11-3, 11-4	Principle of Operation	11-9
Canister		Recirculation System	11-11
Assembly, Closed-Circuit Oxygen		Communications	
SCUBA	14-2	DDC	13-6
Cleaning, Oxygen SCUBA	14-15	Lightweight Mixed-Gas Diving	12-13
Filling		Open Bell	12-16
MK 6 SCUBA	A-2	PTC	13-4
Recirculating Helmet	12-8	Surface-Supplied Mixed-Gas Diving	12-19
Loading, Oxygen SCUBA	14-10	Systems	
Recirculating Helmet	12-3, 12-5	DDC DDS MK 2	13-22
Carbon Dioxide		DDS	13-7
Absorbent		Failure	
PTC	13-4	DDC	13-15

PTC	13-16	Saturation Diving, He-O ₂	17-1—17-16
PTC DDS MK 2	13-18	SCUBA Decompression Tables	16-1—16-18
Unscrambler	12-19	Table Selection	15-1
Compressed Air		Omitted	15-13, 16-8
Handling of	C-10	Schedule, Selection of	15-1
Purity Standards	C-1	Sickness, Treatment of	15-1
Compressibility	C-5	Standard Saturation	17-6
Compression to Saturation Depth	17-4	Tables, Mixed-Gas SCUBA	16-1—16-10
Constant Mass Flowrate Systems	11-5	He-O ₂ SCUBA Table	16-1—16-8
Contamination of Chamber		He-O ₂ SCUBA Table Using	
Atmosphere	10-19	Oxygen	16-1
Continuous-Flow Mixing	C-5, C-8	He-O ₂ SCUBA No Decompression	
Controls and Instrumentation, PTC	13-4	Limits Table	16-5
Control Console		He-O ₂ SCUBA Residual Helium	
DDS	13-6	Timetable for Repetitive Dives	16-5, 16-6
DDS MK 2	13-24	Nitrogen-Oxygen SCUBA Tables	16-7—16-10
Controls		Deep Diving Systems	
DDC	13-4	Applications	10-2, 10-11, 13-2
LSS	13-6	DDS MK 1	9-9, 13-1
Convulsions	9-18	DDS MK 2	9-9, 13-18
Treatment of	15-12	Control Console	13-24
Cousteau, Jacques Yves	9-8, 9-9	Deck Decompression Chamber	13-23
Critical Flow	11-7	General Characteristics	13-19
Cylinder		Life Support System	13-25
Charging		Operational Data	13-26
MK 6 SCUBA	A-1	Personnel Transfer Capsule	13-18
Oxygen SCUBA	14-9	SPCC and Winch	13-22
Closed-Circuit Oxygen SCUBA	14-4	Emergency Operations	13-15
Data	C-4	Deck Decompression Chamber	
Diving Gases	C-1	Communications failure	13-15
Handling of	C-10	Fire	13-15
Daily Routine Schedule, Saturation		Life support failure	13-16
Decompression	17-7	Monitoring failure	13-16
Dalton's Law	9-14	Pressure loss/increase	13-15
Data Collection and Analysis	10-2	Personnel Transfer Capsule	
Davis Lung	9-2	Communications failure	13-17
Davis, Sir Robert H.	13-1	Entanglement	13-16
Deck Decompression Chambers		Power loss	13-17
DDS MK 2	13-18	Pressure loss and flooding	13-17
Emergencies	13-15	General Characteristics	10-11
General	13-4	History of	9-9, 13-1
Deck Winch	13-27	Major Components	13-3
Decompression	13-16, 13-27	Operations	13-9
Automatic Controller DDC	13-7	Observation Diving	13-10
Mixed-Gas	15-1, 16-1, 17-1	Non-Saturation Diving	13-11
General Instructions	15-1	Saturation Diving	13-13
He-O ₂ Surface-Supplied		U. S. Navy Deep Diving Systems	13-1
Decompression Tables	15-2—15-24		

Deep-Sea Mixed-Gas Diving			
Procedures	12-7		
Canister Filling	12-8		
Dressing	12-8		
In-Water	12-11		
Deep-Sea Mixed-Gas Outfit (MK 5)	12-1		
Dress Group	12-6		
Helmet Group	12-3		
Hose Group	12-6		
Main, Tools, Spares Group	12-6		
Depth Limits			
Diving Procedures	10-4		
Semiclosed UBA	11-5		
UBA	11-11		
Depth-Time Limits, Oxygen Diving	14-1		
Differential Pressure Gage	11-8		
Adjustment, MK 6 SCUBA	A-4		
Distortion of Speech	9-21		
Dive Profile	15-5, 15-6		
Diver's Mask USN MK 1	9-5, 9-6, 10-8		
	12-13		
Used from PTC	13-9		
Diving Chart, He-O₂	15-9, 15-10		
Diving from PTC	13-9		
Diving Gases	C-1		
Purity Standards and Cylinder Data	C-1		
Mixing Procedures	C-5		
Analyzing Procedures	C-9		
Diving Procedures			
Oxygen SCUBA	14-14		
Surface-Supplied Mixed-Gas Diving	12-7		
Deep-Sea He-O ₂ Diving	12-8		
Lightweight Diving	12-13		
Diving Team, Mixed-Gas	10-12		
Dress, Deep-Sea Mixed-Gas Outfit	12-13		
Dress Procedures			
Deep-Sea He-O ₂ Outfit	12-8		
MK 6 SCUBA	A-4		
Oxygen SCUBA	14-11		
Duration			
Oxygen SCUBA	14-2		
Emergencies			
DDS Operations	13-15		
DDC Emergencies	13-15		
PTC Emergencies	13-16		
Omitted Decompression			
Mixed-Gas SCUBA	16-8		
Mixed-Gas Surface-Supplied			
Diving	15-1		
Emergency			
Air Table	15-9—15-11		
Decompression Procedures	15-9		
Helium-Oxygen Table	15-11		
Limits, Oxygen Diving	14-1		
Emerson Closed-Circuit SCUBA	9-7, 14-1		
Entanglement of PTC	13-16		
Entrance Lock			
DDS	13-5		
Equipment Test with Activated			
Gas Supply	D-5		
Equivalent Air Depth	16-7		
Exceptional Exposures			
General Instructions	15-1		
Nitrogen-Oxygen Diving	16-8		
Exceptional Operations, Oxygen			
Diving	14-1		
Exceptional Oxygen Partial Pressure			
Exposure Limits	15-2		
Excursion Timetables	17-4—17-6		
Exhaust, UBA	11-8		
Exhaust Valve, Recirculating			
Helmet	12-5		
Experimental Diving Unit	9-3, 9-4		
External Ear Prophylaxis	17-8		
Fire In Chamber, Causes of	10-18		
Fire In DDC	13-15		
Fire Protection, DDC	13-5		
Flammability, Hyperbaric	10-18		
Fleuss, Henry	9-1		
Flow Adjustment, MK 6 SCUBA	A-3		
Flow Schematic			
Diver's Mask USN MK 1	12-14		
Free Ascent of PTC	13-17		
Free Escape Apparatus	9-2		
Gas Analysis	C-9		
Gas Controls DDS	13-7		
Gas Loss, Oxygen SCUBA	14-15		
Gases, Safe Handling of	C-1		
Gas Supplies, Mixed-Gas Diving	12-7		
Gas Supply			
Closed-Circuit UBA	11-9		
Requirements of	10-12—10-17		
UBA	11-8		
Gas Supply Systems			
DDC	13-7		
DDS MK 2	13-24		
PTC	13-4		
DDS MK 2	13-20		

Gas Transport	9-16	Hydrogen-Oxygen Diving	9-4
General Gas Law	9-12	Hyperbaric Flammability	10-18
Habitat Applications	10-2	Hypoxia	9-18
Handling of Cylinders	C-10	Ignition Sources, DDS	13-5
Handling System, PTC	13-8	Indication of Flow, UBA	11-8
Hatches		Inert Gases, use During Decompression	9-20
DDC	13-5	Inert Gas Partial Pressure Instrumentation, PTC	15-2
PTC	13-4	In-Water Decompression, Procedures for	13-4
Head, DDC	13-6	In-Water Treatment, Omitted Decompression	15-4
Heating and Cooling, DDC	13-6	Joint Pains	16-8
Heating, PTC	13-4	Keller, Hannes	9-21
Heat Loss		Lambertson, Dr. C. J.	9-4
Hose	12-17	LARU	9-2, 9-4, 9-8
In Diving	9-20	Leak Test, Oxygen SCUBA	9-2
Helium-Oxygen		Life Jacket	14-10
Diving, History of	9-4	Life Support Equipment	14-11
Partial Pressure Table	15-3	DDC	13-6
SCUBA Decompression Table	16-1—16-3	PTC	13-4
Using Oxygen	16-1, 16-4	Life Support System	
SCUBA No-Decompression Limits Table	16-5	Checkout, Saturation Diving	17-1
SCUBA Residual Helium Timetable for Repetitive Dives	16-5	DDS, General	13-6
Supply, Loss During Ascent	15-12	DDS MK 2	13-25
Surface-Supplied Decompression Tables	15-15—15-24	Failure of	13-16
Decompression Procedures	15-4	Lighting, PTC	13-4
Emergency Decompression Procedures	15-11	Lightweight Gear, Applications	10-2, 10-8
Inert Gas Partial Pressure	15-2	Lightweight Mixed-Gas Diving	
Oxygen Limits	15-2	Deploying the Open Bell	12-15
Helium		General Characteristics	10-8
Purity Standards	C-1	Lightweight Mixed-Gas Outfit	12-13
Residual	16-5	Diver's Mask USN MK 1	12-13
Speech	9-21	Open Bell	12-15
Tremor	9-21	Limitations of Semiclosed-Circuit UBA	11-5
Voice	12-18	Link, E. A.	9-8, 13-1
Voice Unscrambler, DDS	13-7	Low-Pressure Circuit Check, Maintenance, Surface-Supplied Equipment	12-12, 12-13
Helmet, Recirculating	12-3	Major Components of DDS	13-3
Henry's Law	9-15	Mass Flow Control UBA	11-7
High Pressure Nervous Syndrome	9-21	Mass Flow, Indication	11-8
Hoke Valve	12-3	Maximum Voluntary Ventilation	9-16
Horizontal Mating, DDS	13-4	Medical Lock, DDC	13-5
Hose Heat Loss	12-17	Minimum Equipment	
Hose, Pre-dive Inspection	D-2, D-4, D-7	MK 6 SCUBA	A-1
Hot Water Suit	12-17		
Hot Water Supplies, DDS	13-7		
Humidity Control, DDC	13-6		

Minimum Safe Inspired Gas		Pre-Dive Preparation	11-15, A-1
Temperature Limits	9-20, 17-1	Troubleshooting	A-5
Mixed-Gas Diving		MK 11 MOD 0 UBA	
Equipment	9-4	Ancillary Equipment	11-22
History of	9-1	Application	11-11
Physics	9-10—9-15	Backpack	11-18
Physiology	9-16—9-22	Breathing Circuit	11-20
Support Requirements	10-2	Components	11-18
Tables, Development of	9-7	Depth Limits	11-11
Theory	9-1—9-22, 10-1—10-20	Diver Umbilical	11-18
		Facemask	11-18, 11-21
		General Characteristics	9-6, 10-11
Mixed-Gas Diving Apparatus		Operating Modes	11-19
CO ₂ Absorbent Usage	10-15	Set-up Kit	11-22
Cylinder Capacities	10-16	Thermal Protection	11-18, 11-22
Depth Limits	10-4	MK 15 MOD 0 UBA	9-7, 10-10
Gas Consumption Rates	10-15	Electronics Assembly	11-22
General Characteristics		Equipment Case Assembly	11-22
Closed-Circuit Diving	10-10	Recirculation System	11-22
Deep Diving Systems	10-11	Pneumatics Assembly	11-22
Lightweight Diving	10-8	Special Operational Considerations	11-22
MK 6 Semiclosed-Circuit Diving	10-9	MK 12 Diving Apparatus	9-6, 10-7
Oxygen Diving	10-5	MK 14 Diving Apparatus	9-6
Recirculating Deep-Sea Diving	10-6, 10-7	Monitoring of Flow, UBA	11-8
Mixed-Gas		Mouthpiece Assembly, Oxygen	
Mixing Procedures	C-5	SCUBA	14-6
SCUBA	9-6	Multiple Cylinder Mixing	C-6
Applications	10-2—10-11	Neon, Physiological Limitations	9-16
Selection of	12-7	Nitrogen-Oxygen	
Supply, Pre-Dive Check	D-1, D-4, D-6	SCUBA Tables	16-7—16-9
UBA	11-1—11-25	Nitrogen, Purity Standards	C-1
Carbon Dioxide Removal	11-2	No-Decompression Limits,	
Component Arrangement	11-9	Excursion Diving	17-4
Depth Limits	11-5, 11-11	No-Decompression Table, SCUBA	16-5
Gas Addition, Exhaust and		Nohl, Max Gene	9-4
Monitoring	11-3	Non-Return Valve, Recirculating	
History of	11-1	Helmet	12-5
Recirculation	11-2	Non-Saturation Diving, DDS	13-2
Mixing Procedures	C-5	Non-Saturation Diving from PTC	13-11
MK 6 MOD 0 SCUBA		Non-Saturation Mixed-Gas Diving	9-3—9-7
Application	11-11	Objective, Definition of	10-1
Breathing Circuit	11-12	Observation Diving from PTC	13-2, 13-10
Components	11-13	Open Bell	12-15, 12-16
Depth Limits	11-11	Open-Circuit Demand Breathing	
Diving Procedures	11-16	Apparatus Selection of PPO₂	17-2
Flow Monitoring	11-8	Operations Planning	10-1—10-11
Flow Rate Table	11-16	Oxygen Analysis and Control,	
General Characteristics	9-6, 10-9	Closed-Circuit UBA	11-9
Post-Dive Maintenance	11-17		

Oxygen Consumption vs Work Rate	14-3	Personnel Transfer Capsule	13-3
Oxygen Diving		Emergencies	13-16
General Characteristics	10-5	Physics of Mixed-Gas Diving	9-10—9-15
History of	9-1	Planning of Diving Operations	10-1—10-13
Oxygen Diving Operations	14-1	Post-Dive Procedures	14-14
Closed-Circuit Oxygen SCUBA	14-2	Oxygen SCUBA	14-14
Donning Equipment	14-11	Surface-Supplied Mixed-Gas Diving	12-12
Handling and Assembly	14-8	Power Control Console	
Oxygen Depth-Time Limits	14-1	DDS General	13-7
Post-Dive Procedures	14-14	DDS MK 2	13-24
Pre-Dive Equipment Preparation	14-9, 14-11	Power Distribution, DDS	13-6, 13-7
Shipment and Storage	14-16	Pre-Dive Checklist, Surface-Supplied Mixed-Gas Diving	D-1
Troubleshooting	14-15	Pre-Dive Preparation, Oxygen SCUBA	14-9
Underwater Procedures	14-14	Pressure Loss or Increase in DDC	13-5
Oxygen		DDS MK 2	13-18, 13-25
Handling of	C-10	Pulmonary Oxygen Poisoning	9-19
Limit to Support Combustion	10-18	Pulmonary Ventilation	9-16
Oxygen Monitoring		Purafil	10-19
DDC	13-6	Purity Standards, Diving Gases	C-1
PTC	13-4	Recirculating Deep-Sea Diving	
Oxygen Partial Pressure Limits Table	9-18, 15-2	General Characteristics	10-7
Oxygen Partial Pressure Monitoring of Saturation Decompression Sickness Treatment	11-9, 13-7	Recirculating Device, Helmet	12-3
Oxygen Poisoning	9-17	Recirculating Helmet	12-3
Central Nervous Systems	9-17	Recirculating System, Closed-Circuit UBA	11-11
Prevention of and Treatment	9-18	Recirculation System Failure, UBA	11-3
Pulmonary	9-19	Recirculation, Principle of UBA	11-2
Symptoms of	9-17—9-19	Recompression Chamber	
Oxygen, Purity Standards	C-1	Pre-Dive Check	D-2, D-5, D-7
Oxygen Rebreather	14-1	Used for Omitted Decompression	16-10
Oxygen SCUBA, Applications	10-2, 10-5	Recordkeeping, Mixed-Gas Diving	12-13
Oxygen Supply Percentage, Maximum for UBA	11-5, 11-6	Regulator, Closed-Circuit Oxygen SCUBA	14-4
Oxygen Toxicity	9-17	Failure of	14-16
History of	9-2	Repetitive Dives	
Problems during Ascent	15-12	Following Exceptional Exposures	15-8
Using UBA	11-3—11-5	General Instructions	15-1
Oxygen, Use in Decompression Partial Pressure	9-20	Repetitive Dive Procedures	
Inert Gas	15-2	Nitrogen-Oxygen	16-8
Law of	9-14	Helium-Oxygen	16-5
Mixing by	C-1	Residual Helium Time	16-5
Oxygen	15-2	Residual Nitrogen Time	16-8
Personnel Requirement Chart	10-13	Respiratory Heat Loss	9-21
		Roving Bell	12-15
		Safe Handling of Gases	C-10
		Salvage Diving System 450	13-1

Sanitary System DDC	13-5	DDS	13-7
Saturation Decompression	17-7	DDS MK 2	13-22, 13-26
Saturation Diving		Surface Decompression, Procedures for	15-5
Advantages of	17-1	Surface Decompression Tables	
DDC or Habitat Depth	17-1	Use after Nitrogen-Oxygen Dives	16-7
Emergency Gas Mixtures	17-1	Use for Omitted Decompression	16-8
Treatment Gas Mixtures	17-1	Surface-Supplied Mixed-Gas Diving Equipment	
Breathing Apparatus PPO ₂		Accessory Equipment	12-16
Selection	17-1	Communications	12-19
Compression to Saturation Depth	17-4	Deep-Sea Outfit	12-1
Decompression Sickness Treatment	17-7	Lightweight Outfit	12-13
Fire Protection	17-2	Spare Parts	12-6
Records	17-2	Tools, Maintenance	12-6
Establishment of Chamber		Surface-Supplied Mixed-Gas Diving Operations	12-1—12-24
Atmosphere Control	17-3	Diving Procedures	12-7
Excursion Diving	17-1—17-14	Gas Supply Systems	12-7
Unlimited Duration Excursion Table	17-7	Pre-Dive Checklist	D-1—D-8
From PTC	13-13	Post-Dive Procedures and Maintenance	12-12
History of	9-8	Tape Recorder, DDS	13-7
Initial Compression	17-4	Tektite 1	9-8
Life Support System Checkout	17-4	Temperature Balance	9-20
Planning for	10-1	Temperature	
Procedures	17-1—17-16	In Saturation Chamber	17-1
Standard Saturation Decompression	17-7	Minimum Safe Inspired Gas Limits	17-1
Saturation Excursion Diving		Thermal Protection	
Emergencies	13-17	Hot Water Suit	12-17
History of	9-9	Requirements of	9-20
Scrubber, UBA	11-2	Thomson, Elihu	9-3
Schedule, Selection of Decompression	15-1	Toilet, DDC	13-6
SCUBA, Mixed-Gas	9-5	Tools, Surface-Supplied Mixed-Gas Diving	12-6
Decompression Tables	16-1—16-18	Troubleshooting	
SEALAB Program	9-8	MK 6 SCUBA	A-5
Selection of Decompression Table	15-1	Oxygen SCUBA	14-15
Selection of Diving Technique	10-2, 10-11	Umbilical	
Semiclosed-Circuit UBA		Diver's PTC	13-4
Exhaust	11-8	PTC	13-7
Flow Systems	11-7	Underwater Breathing Apparatus	13-9
Gas Supply	11-8	DDS	13-9
Limitations	11-5	PTC Storage	13-4
Principle of Operation	11-5	Unscrambler, Voice	12-19
Selection of PPO ₂	17-1	U. S. Navy Approved Mixed-Gas Diving Equipment	10-3
Shipment and Storage, Oxygen		U. S. Navy Deep Diving Systems	13-1
SCUBA	14-16		
Shower, DDC	13-5		
Single Cylinder Mixing	C-5		
Strength-Power-Communication Cable/Winch	13-7		

U. S. Navy UBA	11-11	Used for Flow Indication	11-8
Valve		Volume	
Control, Recirculating Outfit	12-3	Mixing by	C-5, C-8
Hoke	12-3	Waist Valve, Oxygen SCUBA	14-7, 14-8
Recirculating Helmet		Water Leakage Into Oxygen	
Waist Assembly, Oxygen SCUBA	14-7	SCUBA	14-16
Viewports		Weight, Mixing By	C-5, C-9
DDC	13-5	Winches	
PTC	13-4	PTC Downhaul	13-3, 13-16, 13-18
Ventilation, Requirement for	9-16, 9-17	SPCC DDS MK 2	13-22
Venturi		Zetterstrom, Arne	9-4
Flow System	11-7		
Recirculating Device	12-4		

EN

DAT
FILM

4-8

DTI