

SS521-AH-PRO-010

0910-LP-103-2583

REVISION 1

TECHNICAL MANUAL

**U.S. NAVY
DIVING UMBILICAL
(UBA MK 20 AND MK 21)**

DESCRIPTION, MATERIALS,
AND ASSEMBLY

GPC, A Joint Venture
Contract N00024-01-D-4018



SUPERSEDES: SS521-AH-PRO-010, APRIL 1997.

DISTRIBUTION STATEMENT A: APPROVED FOR PUBLIC RELEASE; DISTRIBUTION UNLIMITED.

PUBLISHED BY DIRECTION OF COMMANDER, NAVAL SEA SYSTEMS COMMAND.

SS521-AH-PRO-010

0910-LP-103-2583

REVISION 1

TECHNICAL MANUAL

**U.S. NAVY
DIVING UMBILICAL
(UBA MK 20 AND MK 21)**

DESCRIPTION, MATERIALS,
AND ASSEMBLY

GPC, A Joint Venture
Contract N00024-01-D-4018



SUPERSEDES: SS0521-AH-PRO-010, APRIL 1997.

DISTRIBUTION STATEMENT A: APPROVED FOR PUBLIC RELEASE; DISTRIBUTION UNLIMITED.

PUBLISHED BY DIRECTION OF COMMANDER, NAVAL SEA SYSTEMS COMMAND.

24 FEBRUARY 2005

SS521-AH-PRO-010

LIST OF EFFECTIVE PAGES

Date of Issue:

Original 0 April 15, 1997
Revision 1 February 24, 2005

Total number of pages in this publication is 75, consisting of the following:

Page No.	Change No.
Title and A	1
Change Record-1	1
Change Record-2 blank.....	0
Certification Sheet-1 – Certification Sheet-2.....	1
Approval and Procurement-1	1
Approval and Procurement-2 blank	0
i – viii	1
1 – 40.....	1
41 blank.....	1
42 – 56.....	1
A-1	1
A-2 blank	1
Umbilical Ordering Worksheet.....	1

CHANGE RECORD

Change No.	Date	Title and/or Brief Description	Signature of Validating Officer
Revision 1	02/24/05	Revision 1. Revised text to incorporate new technologies and fabrication techniques for ANU umbilical assemblies.	

SS521-AH-PRO-010

THIS PAGE INTENTIONALLY LEFT BLANK.

NAVSEA TECHNICAL MANUAL CERTIFICATION SHEET

NAVSEA 9086/11 (8/88)

TM Identification Number SS521-AH-PRO-010	Publication Date 24 February, 2005
Change No. _____	Revision No. <u>1</u>
Book No. _____	Volume No. _____
	Part No. _____
	Chapter No. _____
	Other No. _____
TM Specification: <u>TMCR NO NDMS-040218-000</u>	
Title: <u>U.S. Navy Diving Umbilical (UBA Mk 20 and Mk 21) Description, Materials and Assembly</u>	

FOR CHANGES AND REVISIONS: (Indicate "NA" if an item is not applicable)

Purpose of Change/Revision: Update technical manual to include new technologies and fabrication techniques for Approved for Navy Use Umbilical Assemblies.

TM/Change/Revision Numbers Superseded: Original

TMDER/ACN Numbers Incorporated: NA

Ship or Equipment Alteration/Field Change (FC)/Engineering Change (EC)

Numbers Incorporated: NA

CERTIFICATION STATEMENT

This is to certify that responsible NAVSEA activities have reviewed the basic technical manual (), revision (X), or change () for acquisition compliance, technical coverage, and printing quality. This form is for internal NAVSEA management use only, and does not imply contractual approval or acceptance of the technical manual by the Government, nor relieve the contractor of any responsibility for delivering the technical manual in accordance with the contract requirements.

NAVSEA SIGNATURES

Activity	Name	Signature	Organization	Code	Date
Acquisition	Robert C. Whaley	<i>Robert C. Whaley</i>	NAVSEA	00C3	<i>24 Feb 2005</i>
Technical	Robert D. Kilpatrick	<i>Robert D. Kilpatrick</i>	NAVSEA	00C33	<i>2-18-05</i>
Printing Release					

SS521-AH-PRO-010

**NAVSEA TECHNICAL MANUAL
CERTIFICATION SHEET**

NAVSEA 9186/11 (8/88)

SYNOPSIS OF CHANGE: Generally describe each significant technical addition, deletion, and change. Use additional pages as necessary.

Revised manual to include new technologies and fabrication techniques.

APPROVAL AND PROCUREMENT RECORD PAGE

APPROVAL DATA FOR:

TITLE OF MANUAL: U.S. NAVY DIVING UMBILICAL
(UBA MK 20 AND MK 21) DESCRIPTION,
MATERIALS, AND ASSEMBLY

APPROVAL AUTHORITY: NAVAL SEA SYSTEMS COMMAND, CODE 00C

CONTRACT NUMBER	QUANTITY OF MANUALS
N00024-01-D-4018	200

REMARKS:
NONE

CERTIFICATION:

DATE: February 24, 2005

It is hereby certified that the Technical Manual for U.S. Navy Diving Umbilical (UBA Mk 20 and Mk 21), to be certified under contract number N00024-01-D-4018, has been approved by the approval authority shown above.

ESSM
Warehouse 12
FISC, Cheatham Annex
Williamsburg, VA 23185

SS521-AH-PRO-010

THIS PAGE INTENTIONALLY LEFT BLANK.

TABLE OF CONTENTS

SECTION/TITLE	PAGE
TABLE OF CONTENTS	i
LIST OF APPENDICES	iii
LIST OF FIGURES	iv
LIST OF TABLES	v
FOREWORD.....	vi
LIST OF ACRONYMS AND ABBREVIATIONS.....	vi
SAFETY SUMMARY	vii

DIVING UMBILICAL DESCRIPTION, MATERIALS, AND ASSEMBLY

1-1	INTRODUCTION	1
2-1	DESCRIPTION.....	1
2-2	UMBILICAL ASSEMBLIES.....	1
2-3	UMBILICAL ASSEMBLIES APPROVED FOR NAVY USE.....	4
2-4	BASIC REQUIREMENTS.....	4
2-4.1	DIMENSIONS OF UMBILICAL HOSES.....	5
2-4.2	MAXIMUM LIFETIME OF UMBILICAL HOSE ASSEMBLIES	5
2-4.3	COMMUNICATION CABLE AND ADAPTERS	5
2-4.4	UMBILICAL HOSE ADAPTERS	5
3-1	UMBILICAL PRODUCTION.....	5
3-1.1	HOSE ASSEMBLY AND TESTING	6
3-1.1.1	Breathing Gas Hose	6
3-1.1.1.1	Breathing Gas Hose Authorized Hoses and Fittings.....	6

SS521-AH-PRO-010**TABLE OF CONTENTS (CONTD)**

SECTION/TITLE	PAGE
3-1.1.1.2 Installation of Fittings to Breathing Gas Hose	6
3-1.1.1.3 Pressure and Load Testing Breathing Gas Hose	8
3-1.1.2 Pneumofathometer Hose	10
3-1.1.2.1 Pneumofathometer Authorized Hoses and Fittings	10
3-1.1.2.2 Installation of Fittings to Pneumofathometer Hose	11
3-1.1.2.3 Pressure Test Pneumofathometer Hose	13
3-1.1.3 Hot Water Hose	14
3-1.1.3.1 Hot Water Hose Authorized Hoses, Fittings, and Assemblies	14
3-1.1.3.2 Installation of Fittings to Hot Water Hose	15
3-1.1.3.3 Pressure Testing Hot Water Hoses	16
3-1.2 COMMUNICATION CABLE INSPECTION, ASSEMBLY, AND TESTING	18
3-1.2.1 Authorized Communication Cable Assemblies	18
3-1.2.2 Waterproof Communication Connectors	18
3-1.2.3 Pre-Installation Testing of Communication Cable	19
3-1.2.4 Communication Cable Preparation	19
3-1.3 TESTING D-RING AND SHACKLE ASSEMBLIES	22
3-1.4 SEIZING HOSES AND FITTINGS	23
3-1.4.1 Seizing D-Rings to Umbilical Assembly	23
3-1.4.2 Seizings Subsequent to D-Ring End Fittings	25
3-1.5 UMBILICAL ASSEMBLY CHAFING PROTECTION	28
3-2 ASSEMBLING THE UMBILICAL	28

TABLE OF CONTENTS (CONTD)

SECTION/TITLE	PAGE
3-2.1 ASSEMBLY OF A 3-PART UMBILICAL	28
3-2.2 ASSEMBLY OF A 3-PART UMBILICAL WITH COMBINED STRENGTH/ COMMUNICATION CABLE.....	29
3-2.3 ASSEMBLY OF A 3-PART SPIRAL-WOUND UMBILICAL	30
3-2.4 ASSEMBLY OF A MULTI -PART UMBILICAL.....	31
4-1 ORDERING UMBILICAL ASSEMBLIES	32
4-1.1 DETERMINING SPECIFICATIONS	32
4-1.2 DETERMINING THE REQUIRED SUBCOMPONENTS.....	32
4-1.2.1 Example of Umbilical Assembly to Be Ordered	33
4-1.3 SPECIFICATIONS FOR THE FABRICATOR.....	36
4-1.4 RECEIPT INSPECTION	36
4-2 COMMUNICATION ADAPTERS AND HOSE ADAPTER WHIPS APPROVED FOR NAVY USE.....	37
5-1 VENDOR CAGE CODES	38
6-1 COMPONENTS AND SUBCOMPONENTS APPROVED FOR NAVY USE	40
6-1.1 PARTS LIST COLUMN DEFINITIONS	40

LIST OF APPENDICES

APPENDIX A – UMBILICAL ORDERING WORKSHEET	A-1
---	-----

LIST OF FIGURES

FIGURE TITLE	PAGE
2-1 Spiral-Wound Umbilical Assembly	2
2-2 Umbilical Assembly w/Separate Strength Member	3
3-1 Representative Swage Fitting Illustrating Hose-to-Ferrule Insertion Dimension	7
3-2 Barbed Hose Connection for Breathing Air Hose	8
3-3 Typical Pressure and Load Test Arrangement	9
3-4 Barbed Hose Connection for Pneumofathometer Hose	12
3-5 Barbed Hose Connection for Hot Water Hose	16
3-6 Waterproof Male and Female Electrical Connectors	19
3-7 Representative Communication Cable Wirings	20
3-8 Representative UBA Wiring Diagram	20
3-9 Seizing D-Ring to Umbilical Assembly	24
4-1 Umbilical Ordering Worksheet	34
4-2 UBA to Umbilical Hose Adapters	37
6-1 Mk 20 3-Part Standard Umbilical Assembly w/Separate Strength Member (Amron).....	42
6-2 Mk 20 Aqualite Spiral-Wound Umbilical Assembly (Mar-Vel).....	44
6-3 Mk 20 3-Part Spiral-Wound Umbilical Assembly (Amron).....	46
6-4 Mk 21 Aqualite 3-Part Spiral-Wound Umbilical Assembly (Mar-Vel).....	48
6-5 Mk 21 3-Part Standard Umbilical Assembly with Separate Strength Member (Amron).....	50
6-6 Mk 21 3-Part Spiral-Wound Umbilical Assembly with Reinforced Communication Cable/ Lifeline (Amron)	52
6-7 Mk 20/21 3-Part Spiral-Wound Umbilical Assembly with Reinforced Communication Cable/Lifeline (Diveline)	54
6-8 Umbilical Communication Cable Wiring.....	56

LIST OF TABLES

TABLE TITLE	PAGE
2-1 Basic Components of a Spiral-Wound Umbilical Assembly.....	2
2-2 Basic Components of an Umbilical Assembly w/Separate Strength Member	3
2-3 Approved for Navy Use (ANU) Umbilical Assemblies	4
3-1 Authorized 3/8” Breathing Gas Hoses and Fittings.....	6
3-2 3/8” Hose Swage Fitting Dimensions.....	7
3-3 Authorized 1/4” Pneumofathometer Hoses and Fittings	10
3-4 1/4” Hose Swage Fitting Dimensions.....	12
3-5 Authorized Hot Water Hoses and Fittings.....	14
3-6 Hot Water Hose Swage Fitting Dimensions	15
3-7 Authorized Communication Cables.....	18
3-8 Seizing Materials List.....	24
3-9 Chafing Cover Part Numbers.....	28
4-1 Part Numbers for UBA to Umbilical Hose Adapters.....	37
4-2 Umbilical Communication Cable Adapters.....	38
5-1 Vendors and CAGE Codes	38
6-1 Parts List, Mk 20 3-Part Standard Umbilical Assembly w/Separate Strength Member (Amron).....	43
6-2 Parts List, Mk 20 Aqualite Spiral-Wound Umbilical Assembly (Mar-Vel).....	45
6-3 Parts List, Mk 20 3-Part Spiral-Wound Umbilical Assembly (Amron)	47
6-4 Parts List, Mk 21 3-Part Aqualite Spiral-Wound Umbilical Assembly (Mar-Vel)	49
6-5 Parts List, Mk 21 3-Part Standard Umbilical Assembly with Separate Strength Member (Amron).....	51
6-6 Parts List, Mk 21 3-Part Spiral-Wound Umbilical Assembly with Reinforced Communication Cable/Lifeline (Amron)	53
6-7 Parts List, Mk 20/21 3-Part Spiral-Wound Umbilical Assembly with Reinforced Communication Cable/Lifeline (Diveline).....	55
6-8 Parts List, Communication Cable.....	56

SS521-AH-PRO-010

FOREWORD

This manual is promulgated to provide definitive guidance in the production of diving umbilicals. Its use by U.S. Navy diving activities is mandatory. Comments and suggestions concerning this manual should be addressed to the Supervisor of Salvage and Diving. (Attention: NAVSEA 00C3)

LIST OF ACRONYMS AND ABBREVIATIONS

ANU	Approved for U.S. Navy Use
AWG	American Wire Gauge
CAGE	Commercial and Government Entity
DLSS	Diving Life Support System
IAW	in accordance with
ID	inside diameter
MIP	Maintenance Index Page
mm	millimeter
MNPT	Male National Pipe Thread
MRC	Maintenance Requirement Card
NA	not applicable
NAVOSH	Navy Occupational Safety and Health
NAVSEA	Naval Sea Systems Command
NID	non-ionic detergent
NSN	National Stock Number
O ₂	oxygen
OPNAV	Office of the Chief of Naval Operations
PMS	Planned Maintenance System
p/n	Part Number
psi	pounds per square inch
PVC	polyvinyl chloride
QD	quick disconnect
RTV	room temperature vulcanizing compound
TM	Technical Manual
UBA	Underwater Breathing Apparatus

SAFETY SUMMARY

This Safety Summary contains all specific Warnings and Cautions appearing elsewhere in this manual. Should situations arise that are not covered by the general and specific safety precautions, the Commanding Officer or other authority will issue orders, as deemed necessary, to cover the situation.

GUIDELINES

Extensive guidelines for safety can be found in *Navy Occupational Safety and Health (NAVOSH) Program Manual for Forces Afloat*, OPNAV Instruction 5100.19 series.

Diving Officers, Diving Supervisors and members of dive teams likely to be involved in the production of diving umbilicals should continuously conduct safety indoctrination lectures and exercises aimed at reducing hazards and at reacting appropriately to unusual situations.

PRECAUTIONS

The following general precautions are offered as part of this Safety Summary:

- All personnel responsible for or engaged in the production of umbilical assemblies should read and comprehend this manual.
- Observe all Warnings, Cautions, and Notes presented herein.
- Know the capabilities of assigned equipment and strictly follow operational procedures.

Special Notations. Warnings, cautions, and notes appearing in this technical manual must be followed in order to prevent hazards to personnel and damage to equipment. Personnel must be thoroughly familiar with all warnings and cautions before operating or performing maintenance on this equipment. Safety notations used throughout the manual are as follows:

WARNING

Indicates a location, equipment, or system where a potential hazard exists capable of producing injury to personnel if approved procedures are not followed.

CAUTION

Indicates a situation in which a hazard could severely damage equipment, a system, or the ship, causing loss of mission capability if approved procedures are not followed.

NOTE

Highlights an essential operating or maintenance procedure, condition, or statement that must be emphasized.

SS521-AH-PRO-010

WARNINGS

The following Warnings appear in the text of this manual and are given here for emphasis.

WARNING

When installing fittings into hoses, no lubricant other than clean fresh water is to be used.

Never use a gas source for a proof test because of the personnel hazard associated with stored energy from the compressed gas.

Stand clear of pressurized hoses and fittings while conducting proof testing.

When installing fittings into hoses, no lubricant other than clean fresh water is to be used.

CAUTIONS

The following Cautions appear in the text of this manual and are given here for emphasis.

CAUTION

When seizing the D-ring to the umbilical assembly, wraps must be tight, but care must be taken to ensure that the pneumofathometer hose, breathing gas hose, and communication cable are not crushed or pinched.

When seizing the umbilical assembly, wraps must be tight, but care must be taken to ensure that the pneumofathometer hose, breathing gas hose, and communication cable are not crushed or pinched.

When installing communication cable using multiple shielded wire pairs, the pairs must be soldered to common circuits (i.e., one red-black pair within a shielded section to the headset, and another red-black pair within a shielded section to the microphone). Failure to follow this caution may result in setting up an induced voltage in the cables, resulting in a loud harmonic frequency noise being produced in the diver's headset.

At no time during assembly should the communication cable be put under stress, unless it is a combination strength/communication cable.

1-1 INTRODUCTION.

The designs and descriptions in this manual have been developed to standardize the production, testing, assembly, and certification of Mk 20 and Mk 21 diving umbilicals used with the Underwater Breathing Apparatus (UBA). The umbilical designs presented here supersede any existing umbilical drawings and should be used for all future procurements. The designs shown in this manual represent current methods and components used to support surface-supplied divers. The figures, tables, and procedures presented in this manual represent the approved components, methods, and techniques used by the umbilical prime vendors to fabricate Approved For Navy Use (ANU) umbilical assemblies. Other manufacturers and fabricators may, by using the information provided in this text, supply umbilical assemblies for Navy use. In addition the designs and specifications allow end users to select the components that best suit their requirements when ordering components for an umbilical.

This manual does not contain detailed designs for umbilical assemblies that incorporate hot water hoses or video or camera cables. For commands that utilize hot water hoses, video cables, or other accessory devices with their umbilical hoses, they may be added to any of the umbilical assemblies as needed to support diving operations. The length of the hose beyond the final umbilical stop (diver's D-ring) must be determined by the local command and is based upon the type and design of the hot water suit being used. The length of hose from the surface tie-down point (surface D-ring) to the diving control station must be determined by the ordering command. These dimensions must be taken into consideration when ordering umbilical assemblies.

2-1 DESCRIPTION.

All diving umbilical hoses shall be assembled or procured using the materials, components, and procedures detailed in this document.

2-2 UMBILICAL ASSEMBLIES.

The basic umbilical assembly consists of a 3/8" breathing gas hose, a 1/4" pneumofathometer hose, and a communication cable. The umbilical assemblies presently in use are of two basic constructions; spiral-wound and parallel. In spiral-wound umbilical assemblies the umbilical fabricator receives components (hoses, strength members, and communication cables) that are pre-wound assemblies which are fitted with the necessary fittings and accessories to produce finished umbilicals. In parallel (taped) assemblies the fabricator receives individual hoses, communication cables, fittings, and strength members to assemble finished umbilicals (see Figures 2-1 and 2-2 and Tables 2-1 and 2-2). The parallel assemblies may have either a combination strength/communication member or a separate strength member and communication cable. Spiral-wound umbilical assemblies do not have a separate strength member, and the assembly derives its strength from its spiral construction. Commands that require additional components within the umbilical assembly to support diving requirements (such as hot water supply hose, camera cable, lighting cable, or other additional components) may add them as accessories in accordance with section 3-2.4 of this manual.

SS521-AH-PRO-010

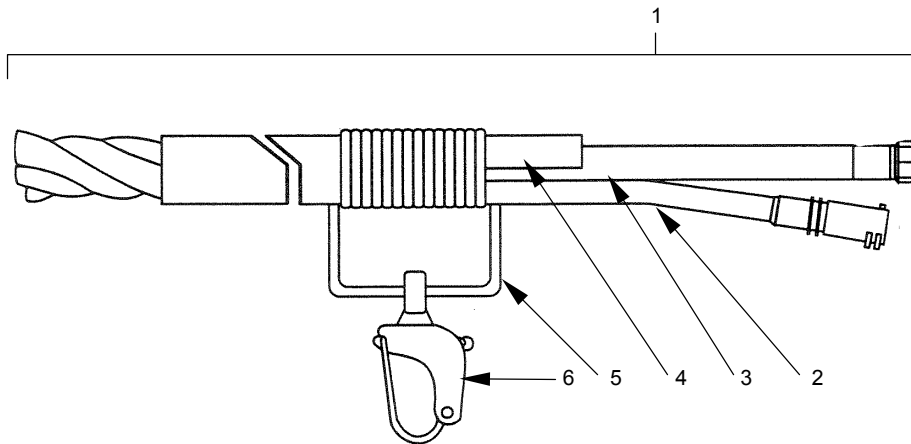

Figure 2-1. Spiral-Wound Umbilical Assembly

Table 2-1. Basic Components of a Spiral-Wound Umbilical Assembly

Fig./Index Number	Part Identification	Notes
2-1-1	Umbilical assembly	Provided in spiral-wound configuration and configured for the Mk 20 mask or Mk 21 helmet.
-2	Communication cable	Require compatible fittings for Mk 20 or Mk 21 UBA (either Marsh Marine female or male telephone) connector on diver end. Surface end requires connections compatible with user's communication system (either male telephone 5- or 6-pin connector or male banana plugs).
-3	Hose, 3/8", breathing gas	Requires 9/16" oxygen fitting on each end. See Table 3-1 for authorized hose and fitting manufacturers and part numbers.
-4	Hose, 1/4", pneumofathometer	Requires 9/16" oxygen fitting on surface end; diver end open to ambient conditions. See Table 3-4 for authorized hose and fitting manufacturers and part numbers.
-5	D-ring	Required on surface and diver end of umbilical. If not procured as a D-ring and shackle combination, or if cut and welded during construction, the D-ring must be load tested to 500-pound dead weight prior to its installation on the umbilical assembly. The D-rings will be seized to the umbilical IAW section 3-1.4 of this manual.
-6	Snap shackle	Required on diver end of umbilical, optional on surface end.

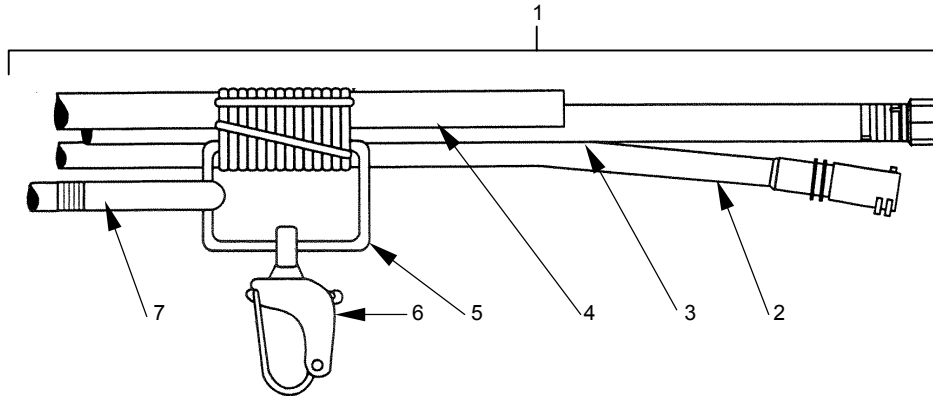

Figure 2-2. Umbilical Assembly w/ Separate Strength Member

Table 2-2. Basic Components of an Umbilical Assembly w/ Separate Strength Member

Fig./Index Number	Part Identification	Notes
2-2-1	Umbilical assembly, w/ separate strength member or w/combination communication cable/strength member	Provided in configurations for the Mk 20 mask or Mk 21 helmet.
-2	Communication cable or combination communication cable/strength member	Require compatible fittings for Mk 20 or Mk 21 UBA (either Marsh Marine female or male telephone) connector on diver end. Surface end requires connections compatible with user's communication system (either male telephone 5- or 6-pin connector or male banana plugs). Combined communication cable/strength member may be used in lieu of separate communication cable and strength member (item -7).
-3	Hose, 3/8", breathing gas	Requires 9/16" oxygen fitting on each end. See Table 3-1 for authorized hose and fitting manufacturers and part numbers.
-4	Hose, 1/4", pneumofathometer	Requires 9/16" oxygen fitting on surface end, diver end open to ambient conditions. See Table 3-4 for authorized hose and fitting manufacturers and part numbers.
-5	D-ring	Required on surface and diver end of umbilical. If not procured as a D-ring and shackle combination, or if cut and welded during construction, the D-ring must be load tested to 500-pound dead weight prior to its installation on the umbilical assembly. The D-rings will be seized to the umbilical IAW section 3-1.4 of this manual.
-6	Snap shackle	Required on diver end of umbilical; optional on surface end.
-7	Synthetic line, double braid, 3/8" (strength member) Minimum strength 4400 lb	Spliced to the D-ring on the diver and surface ends of umbilical assembly. The length is such that all stress is taken on the line when the umbilical is tensioned from the surface.

SS521-AH-PRO-010

2-3 UMBILICAL ASSEMBLIES APPROVED FOR NAVY USE.

The following umbilical assemblies (Table 2-3) are approved for Navy use. Refer to Figures 6-1 through 6-7 and Tables 6-1 through 6-7 for illustrations and parts breakdowns to be used when ordering the assembly, and sections 3-1.2 through 3-1.4 for assembly, testing, and seizing requirements for the individual umbilical assembly components.

Table 2-3. Approved for Navy Use (ANU) Umbilical Assemblies

Mfr/CAGE Code	Figure Number	Part Number	Notes/Description
Amron (6S753)	6-1	33HB1-MK20-MN-0-300	Amron standard Gates 4-part Mk 20 umbilical assembly (breathing air, pneumofathometer hose, communication cable, and strength member). Specify length and fittings required.
Mar-Vel (14819)	6-2	ADU001-639	Mk 20 Aqualite 3-part spiral-wound umbilical. Nominal length is 600', actual length 625'. Specify end fittings.
		ADU-0001-1	Mk 20 Aqualite 3-part spiral-wound umbilical assembly. Nominal length is 300', actual length 330' Specify end fittings and required length.
Amron (6S753)	6-3	UMB-ADU1Mk 21-MM-(Length)	Amron 3-part, spiral-wound, Mk 21 umbilical. Nominal length 600', actual length 625'.
Mar-Vel (14819)	6-4	ADU001-639	Mk 21 Aqualite 3-part spiral-wound umbilical. Nominal length 600', actual length 625'. Specify end fittings and required length.
		ADU-0001-1	Mk 21 Aqualite 3-part spiral-wound umbilical assembly. Specify end fittings and required length.
Amron (6S753)	6-5	33HB1-MK21-MN-0-300	Amron standard Gates 4-part Mk 21 umbilical assembly, 300' (breathing air, pneumofathometer hose, communication cable, and strength member). Specify length and fittings required.
		33HB1-MK21-MN-0-600	Amron standard Gates 4-part Mk 21 umbilical assembly, 600' (breathing air, pneumofathometer hose, communication cable, and strength member). Specify length and fittings required.
Amron (6S753)	6-6	UMB-ADU1Mk 21-MM-(Length)	Amron 3-part, spiral-wound, Mk 21 umbilical. Nominal length 600', actual length 625'.
Diveline (3AY00)	6-7	UDA0103	Aquaflow 3-member spiral-wound umbilical assembly with reinforced communication cable/lifeline. Specify end fittings and required length (Mk 20 and Mk 21).

2-4 BASIC REQUIREMENTS.

NOTE

A total of three connecting and/or repair fittings are authorized in a 300-foot run of breathing gas hose, as long as the overall length does not exceed the nominal length of the hose.

2-4.1 DIMENSIONS OF UMBILICAL HOSES. All U.S. Navy diving umbilical assemblies shall consist of, as a minimum, a 3/8-inch ID breathing gas hose, a 1/4-inch ID pneumofathometer hose, a communication cable, a strength member (the communication cable and strength member may be an integrated unit), and a D-ring with a snap shackle installed on the diver end of the assembly. When procured, the umbilical assembly shall have a maximum overall length of 600 feet ($\pm 10\%$), measured from the terminal end connections of the diver's breathing air hose. The length between the diver and surface end D-rings will depend on the required length of breathing air hose, communication cable, and pneumofathometer hose (whichever is longest) from the diver's D-ring to the diver mask or helmet, and the required length of breathing air hose, communication cable, and pneumofathometer hose (whichever is longest) from the surface D-ring to the dive station. See Figures 6-1 through 6-8 for hose and communication cable terminal dimensions. A combination strength/communication cable may be used in place of separate communication and strength members. When required by operational necessity, and at the discretion of the end user, shorter lengths of umbilical assemblies may be procured.

NOTE

The breathing gas hose must be capable of withstanding a pressure that is equal to or greater than the rated working pressure of the system with which it interfaces.

2-4.2 MAXIMUM LIFETIME OF UMBILICAL HOSE ASSEMBLIES. The maximum life of the rubber breathing gas hose is 12 years (per Planned Maintenance System (PMS), Maintenance Index Page (MIP) 5921XY) and may remain in service throughout that time frame as long as it is deemed satisfactory in accordance with Maintenance Requirement Cards (MRC) 5921/039 24M-1R and 60M-1R. Synthetic umbilical assemblies do not have a maximum lifetime limit, and the assembly may remain in service as long as it is deemed to be satisfactorily in accordance with MRCs 5921/039 24M-1R and 60M-1R.

2-4.3 COMMUNICATION CABLE AND ADAPTERS. The communication cable must be of 4-wire or 6-wire construction and capable of providing round-robin communication. If necessary, or if the command is required to operate both the Mk 20 and Mk 21 UBAs, communication interface adapter(s) (see Table 4-2) must be used.

2-4.4 UMBILICAL HOSE ADAPTERS. Umbilical hose adapter(s) (see Figure 4-2 and Table 4-1) may be procured for use with the umbilical assembly to allow connecting a Mk 20 mask to a Mk 21 umbilical assembly or a Mk 21 helmet to a Mk 20 umbilical assembly.

3-1 UMBILICAL PRODUCTION.

The umbilical shall be assembled in accordance with the applicable diagrams and assembly instructions. Only one diagram shall be used for each umbilical. If the command's mission requires the use of both the Mk 20 mask and the Mk 21 helmet, only one type of umbilical is required, provided the proper interface leader is used for each application. Components are seized together using marline or nylon fiber cord and wrapped with Polyken or duct tape; or optionally wrapped with just Polyken or duct tape as indicated in the appropriate diagram and/or section 3-2, Assembling the Umbilical. The umbilical

SS521-AH-PRO-010

shall be assembled so that the strength member always carries the full strain of any load applied to the umbilical when worn by the diver. A protective cover may be placed over the umbilical at the diver end to guard against abrasion. The following procedures list the steps that are common to all types of umbilical assemblies. Each procedure is to be used to install or repair an umbilical assembly subcomponent as necessary.

3-1.1 HOSE ASSEMBLY AND TESTING.

3-1.1.1 Breathing Gas Hose. The breathing gas hose shall be assembled and tested as follows:

3-1.1.1.1 Breathing Gas Hose Authorized Hoses and Fittings. Table 3-1 shows the breathing gas hoses and fittings authorized for use in umbilical assemblies.

Table 3-1. Authorized 3/8" Breathing Gas Hoses and Fittings

Mfr/CAGE Code	Hose Part Number	Fitting Part Number (Mfr)	Notes
Diveline (3AY00)	HDA0106		Aquaflow 3/8" thermoplastic hose, 500-psi working pressure
		FXSP20606 (Diveline)	Fitting, swage, 3/8" ID hose to 9/16-18 O ₂ nut
		AHB-60202 (Amron)	Fitting, 3/8" ID hose barb to 9/16-18 O ₂ nut
JDR (0Y0B0)	HAL0106		Aqualite 3/8" thermoplastic hose, 500-psi working pressure
		XF06SP1F06 (JDR)	Fitting, swage, 3/8" ID hose to 9/16-18 O ₂ nut
Gates (24161)	33HB-3/8		Gates, 3/8" rubber hose, 1125-psi working pressure
		AHB-60202 (Amron)	Fitting, 3/8" ID hose barb to 9/16-18 O ₂ nut
		JS0243 (Band-It-Idex)	Clamp, preformed, 1", smooth ID, used with AHB-60202 fitting.
Barfield (0GM59)	BAR12A-038-BG		Barfield 3/8" ID rubber hose
		AHB-60202 (Amron)	Fitting, 3/8" ID hose barb to 9/16-18 O ₂ nut
		N7-BG (Divers Supply)	Fitting, 3/8" ID hose barb to 9/16-18 O ₂ nut
		E157ALP82 (Mar-Vel)	Fitting, 3/8" ID hose barb to 9/16-18 O ₂ nut
		JS0243	Clamp, preformed, 1", smooth ID, used with AHB-60202, N7-BG, and E157ALP82 fittings.

3-1.1.1.2 Installation of Fittings to Breathing Gas Hose. Install fittings in accordance with the following procedures:

WARNING

When installing fittings into hoses, no lubricant other than clean fresh water is to be used.

NOTE

Refer to the appropriate figure and table for subcomponent part numbers prior to assembling any umbilical assembly.

a. Installation of Swage Fittings:

1. Refer to Figures 6-1 through 6-7 and Table 3-1 to determine the fittings required for the hose application. See also Table 3-2 for swage fitting dimensions.
2. Install swaged fitting to hose as follows:
 - a) Using a sharp blade, cut the hose to the required length. After cutting, the hose end should be square and clean (no nicks, gouges, or other damage).
 - b) Clean the hose bore to remove any loose plastic cuttings.
 - c) Measure the ferrule from the hose entry end of the ferrule to the inner shoulder of the spigot (see Figure 3-1). Measure this distance from the end of the hose and mark it circumferentially.

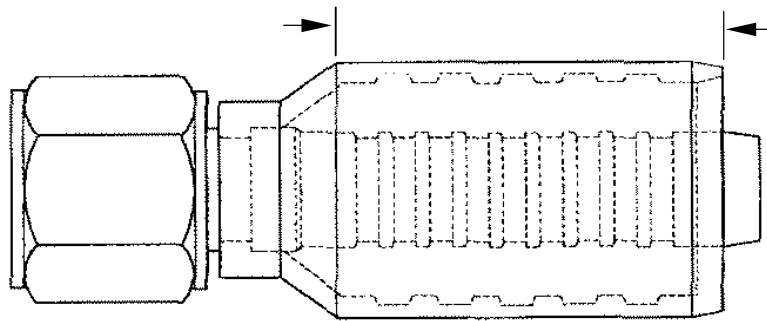

Figure 3-1. Representative Swage Fitting Illustrating Hose-to-Ferrule Insertion Dimension

- d) Slide spigot into hose until the ferrule reaches the mark made in step c.
- e) Insert the hose and the ferrule into the crimping machine. Verify that the ferrule is fully inserted into the die.

Table 3-2. 3/8" Hose Swage Fitting Dimensions

Manufacturer	Coupling P/N	Swage (post crimp) Diameter (mm)	Spigot Bore Diameter (mm)
JDR	XF06SP1F06	21.8 ± 0.1	7.02
Diveline	FXFSP20606	18.7 ± 0.1	Decrease of .25mm

SS521-AH-PRO-010

- f) Using a suitable 8-finger crimping machine, crimp the ferrule to its finished diameter. After crimping the ferrule, verify the spigot bore diameter with a suitably sized tapered go/no-go gauge.
- g) Remove the fitting from the crimping machine.

b. Installation of Barb Fittings (see Figure 3-2):

- 1. Verify that the barb fitting nut is placed over the fitting in the proper orientation for use.

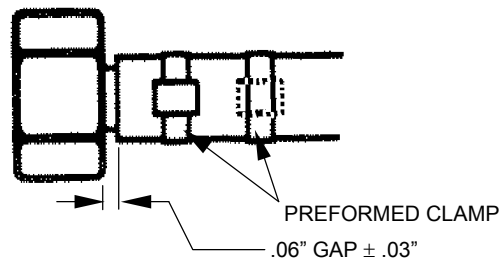

Figure 3-2. Barbed Hose Connection for Breathing Air Hose

- 2. Insert the hose barb into the hose, leaving a gap of $.06'' \pm .03''$ between the end of the hose and the fitting nut.

NOTE

When installing barb-style fittings the hose barb-to-hose connection will be secured with either two or three preformed clamps. If two clamps are used, the buckles will be positioned 180° apart; if three clamps are used the buckles will be positioned 120° apart.

- 3. Install preformed clamps to secure the hose to the hose barb.

3-1.1.1.3 Pressure and Load Testing Breathing Gas Hose. After crimping fittings onto the hose, pressure and load test the hose as follows:

WARNING

Never use a gas source for a proof test because of the personnel hazard associated with stored energy from the compressed gas.

NOTE

A proof test is a nondestructive pressure test that is applied to a hose assembly to determine reliability under normal working pressure and to ensure that fittings are installed correctly. As a minimum, the proof test shall be conducted to twice (200%) the maximum system operating pressure (operating pressure for breathing air is 250 psi). Filtered tap water is typically used as a test medium for Diving Life Support System (DLSS) hoses.

- a. Inspect hose to be tested for damage, bulges, swelling, cuts, and abrasions.
- b. Mark each fitting around its circumference at the point where the fitting meets the hose cover.
- c. Using appropriate fittings, connect the hose to the pressure source (see Figure 3-3).

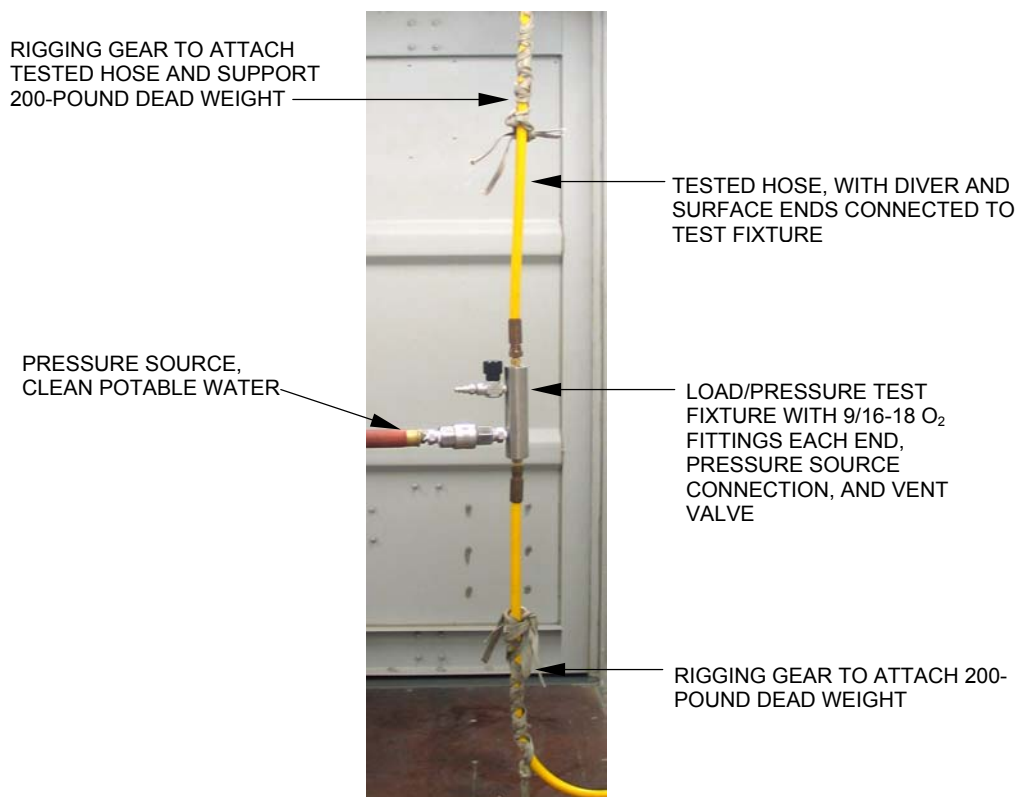

Figure 3-3. Typical Pressure and Load Test Arrangement

- d. Using appropriate rigging components, attach the hose to a lifting device and to a 200-pound dead weight.

WARNING

Stand clear of pressurized hoses and fittings while conducting proof testing.

SS521-AH-PRO-010

- e. Pressurize the hose to twice the working pressure of the system or 750 psi (whichever is less) and hold the pressure for a minimum of 10 minutes. While pressurized, inspect the hose for swelling, bulges, separation of fittings from the hose, and evidence of leaks. Any of these conditions renders the hose unsatisfactory.
- f. If pressure in step e. is greater than 500 psi, reduce the pressure to 500 psi. Using the rigging components, lift the hose assembly until the 200-pound dead weight is approximately 4 to 6 inches off the ground and hold for 10 minutes. Inspect the fitting(s) for proper attachment, alignment, and for separation from the hose. The hose is satisfactory if there is no apparent change to the hose or fitting during the course of the test.
- g. Lower the test weight to the ground and release test pressure. Inspect the marks at the fittings. If the marks have “creeped” more than 1/16” during the course of testing, the hose is unacceptable.
- h. Disconnect and drain the hoses.
- i. Prior to placing the hose into service, clean the assembly with soap (NID) and water, and flush it with fresh water to remove all residual soap and contaminants.

NOTE

Testing of hose assemblies shall be documented in writing as to manufacturer, date of manufacture, testing activity, test date, and proof test pressure. Permanent tags with this information shall be installed on the surface end of the hose assembly.

- j. If the hose is satisfactory, install test tag showing manufacturer, date of manufacture, test activity, test pressure, and date.

3-1.1.2 Pneumofathometer Hose. The pneumofathometer hose shall be assembled and tested as follows:

3-1.1.2.1 Pneumofathometer Authorized Hoses and Fittings. The following pneumofathometer hoses and fitting are authorized for use in umbilical assemblies. See Table 3-3.

Table 3-3. Authorized 1/4” Pneumofathometer Hoses and Fittings

Mfr/CAGE Code	Hose Part Number	Fitting Part Number (Mfr)	Notes
Diveline (3AY00)	HDA0104		Aquaflow 1/4” thermoplastic hose, 250-psi working pressure
		FXFSB10604 (Diveline)	Fitting, swage, 1/4” ID hose to 9/16-18 O ₂ nut for 250-psi, 1/4” Aquaflow hose.
		AHB-40202 (Amron)	Fitting, hose barb to 9/16-18 O ₂ nut, for use with HAL0104 1/4” ID hose.

Table 3-3. Authorized 1/4" Pneumofathometer Hoses and Fittings (contd)

Mfr/CAGE Code	Hose Part Number	Fitting Part Number (Mfr)	Notes
JDR (0Y0B0)	HAL0104		Aqualite 1/4" thermoplastic hose, 500-psi working pressure
		XF06SP3F04 JDR	Fitting, swage, 1/4" ID hose to 9/16-18 O ₂ nut
Aeroquip (0X660)	FC384-04		Hose, 1/4", 250-psi working pressure
		FC5853-04-04B Aeroquip	Fitting, hose barb to 9/16-18 O ₂ nut, for use with Aeroquip 1/4" ID hose.
		JS0401 (Band-It-Idex)	Clamp, preformed, 13/16", smooth ID, used with FC5853-04-04B fitting.
		JS0243 (Band-It-Idex)	Clamp, preformed, 1", smooth ID, used with AHB-60202, N7-BG, and E157ALP82 fittings.
Saint-Gobain (85757)	3600-040-XX		Hose, 1/4", 250-psi working pressure, pneumofathometer hose
	3630-040-XX		
		390A-04546	Fitting, hose barb to 9/16-18 O ₂ nut, for use with 3600-040 1/4" ID hose.
		3906-04546	Fitting, hose barb to 9/16-18 O ₂ nut, for use with 3630-040 1/4" ID hose.
		JS0243 (Band-It-Idex)	Clamp, preformed, 1", smooth ID, used with 390A-04546 and 3906-04546 fittings.
		AHB-40202 (Amron)	Fitting, hose barb to 9/16-18 O ₂ nut, for use with 3630-04Y 1/4" ID hose.
		JS0401 (Band-it-Idex)	Clamp, preformed, 13/16", smooth ID, used with AHB-40202 fitting.

3-1.1.2.2 Installation of Fittings to Pneumofathometer Hose. Install fittings in accordance with the following procedures:

WARNING

When installing fittings into hoses, no lubricant other than clean fresh water is to be used.

NOTE

Refer to the appropriate figure and table for subcomponent part numbers prior to assembling any umbilical assembly.

- a. Installation of Swage Fittings (see Table 3-4 for fitting dimensions):
 1. Using a sharp blade, cut the hose to the required length. After cutting, the hose end should be square and clean (no nicks, gouges, or other damage).
 2. Clean the hose bore to remove any loose plastic cuttings.

SS521-AH-PRO-010

3. Measure the ferrule from the hose entry end of the ferrule to the inner shoulder of the spigot (see Figure 3-1). Measure this distance from the end of the hose and mark it circumferentially.
4. Slide the spigot into the hose until the ferrule reaches the mark made in step 3.
5. Insert the hose and the ferrule into the crimping machine. Verify that the ferrule is fully inserted into the die.
6. Using a suitable 8-finger crimping machine, crimp the ferrule to its finished diameter. After crimping the ferrule, verify the spigot bore diameter using a suitably sized tapered go/no-go gauge.

Table 3-4. 1/4" Hose Swage Fitting Dimensions

Manufacturer	Coupling P/N	Swage (post-crimp) Diameter (mm)	Spigot Bore Diameter (mm)
JDR	XF06SP3F04	16.1 ± 0.1	4.02
Diveline	FXFSB10604	13.5 to 14.0	4.65

7. Remove the fitting from the crimping machine.

b. Installation of Barb Fittings (see Figure 3-4):

1. Verify that the hose barb fitting nut is placed over the fitting in the proper orientation for use.

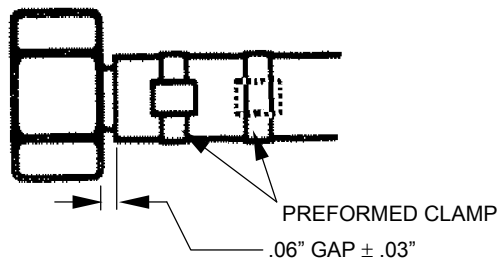

Figure 3-4. Barbed Hose Connection for Pneumofathometer Hose

2. Insert the hose barb into the hose, leaving a gap of .06" ± .03" between the end of the hose and the fitting nut.

NOTE

When installing barb-style fittings, the barb-to-hose connection will be secured with either two or three preformed clamps. If two clamps are used, the buckles will be positioned 180° apart; if three clamps are used the buckles will be positioned 120° apart.

3. Install preformed clamps to secure the hose to the hose barb.

3-1.1.2.3 Pressure Test Pneumofathometer Hose. After crimping fittings onto hose, pressure test the hose as follows:

WARNING

Never use a gas source for a proof test because of the personnel hazard associated with stored energy from the compressed gas.

NOTE

A proof test is a nondestructive pressure test that is applied to a hose assembly to determine reliability under normal working pressure and to ensure that fittings are installed correctly. As a minimum, the proof test shall be conducted to twice (200%) the maximum system operating pressure. Filtered tap water is typically used as a test medium for DLSS hoses.

- a. Inspect hose to be tested for damage, bulges, swelling, cuts, and abrasions.
- b. Mark the end fitting around its circumference at the point where the fitting meets the hose cover.
- c. Using appropriate fittings, connect the hose to the pressure source.
- d. Using the appropriate fitting and clamps, plug the diver end of the pneumofathometer hose.

WARNING

Stand clear of pressurized hoses and fittings while conducting proof testing.

- e. Pressurize the hose to 200 psi and hold the pressure for a minimum of 10 minutes. While pressurized, inspect the hose for swelling, bulges, separation of fitting from the hose, and evidence of leaks. Any of these conditions renders the hose unsatisfactory.
- f. Depressurize the hose and inspect the marks at the hose fitting. If the marks have “creeped” more than 1/16” during the course of testing, the hose is unacceptable.
- g. Disconnect the hose from the test assembly, remove the plug from the diver’s end, and drain the hose.
- h. Prior to placing the hose into service, clean the assembly with soap (NID) and water and flush it with fresh water to remove all residual soap and contaminants.

NOTE

Testing of hose assemblies shall be documented in writing as to manufacturer, date of manufacture, testing activity, test date, and proof test pressure. Permanent tags with this information shall be installed on the surface end of the hose assembly.

SS521-AH-PRO-010

- i. If the hose is satisfactory, install test tag, showing manufacturer, date of manufacture, test activity, test pressure, and date.

3-1.1.3 Hot Water Hose. Hot water hose (if installed) shall be assembled and tested as follows:

3-1.1.3.1 Hot Water Hose Authorized Hoses, Fittings, and Assemblies. The following hot water hoses, fittings, and assemblies listed in Table 3-5 are authorized for use in umbilical assemblies:

Table 3-5. Authorized Hot Water Hoses and Fittings

Mfr/CAGE Code	Hose Part Number	Fitting Part Number (Mfr)	Notes
Gates (24161)	33HB-1/2		Gates hot water supply hose, 1/2"
		AHB-80875 (Amron)	1/2" hose barb with brass female QD to mate to hot water suit
		AHB-80800 (Amron)	Fitting, 1/2" hose barb x 1/2" MNPT, 3" barb
		JS402 (Band-It-Idex)	Clamp, preformed, 1 1/2", smooth ID; used with AHB-80875 and AHB-80800 fittings.
Diveline (3AY00)	HDA1108		1/2" ID Aquaflow thermoplastic hose
		FJFSS10808	Fitting, swage, 1/2" hose to JIC fitting
Mar-Vel (14819)	E102AHW		Hot water supply hose, 1/2"
		E157AQDFM (Mar-Vel)	Fitting, 1/2", quick disconnect, hot water hose, diver end
		JS402 (Band-It-Idex)	Clamp, preformed, 1 1/2", smooth ID; used with AE157AQDFM fitting.
Amron (6S753)	3200-009 (Gates)		Gates Duro Flex Hose, hot water, 1/2" ID, 0.88" OD; specify length when ordering.
		AHB-80875 (Amron)	1/2" hose barb with brass female QD to mate to hot water suit
		AHB-80800 (Amron)	Fitting, 1/2" hose barb x 1/2" MNPT, 3" barb
		JS402 (Band-It-Idex)	Clamp, preformed, 1 1/2", smooth ID; used with AHB-80875 and AHB-80800 fittings.
Mar-Vel (14819)	2024		Hot water hose assembly, 3/4", 300-psi working pressure, manufactured by Custom Design & Fabrication; specify length and fittings when ordering.
Gates (24161)	3204-1425		Hot water hose assembly, 3/4", #310659, manufactured by Gates Rubber Co.; specify length when ordering.
	3204-1416		Hot water hose assembly, 3/4", #310655, manufactured by Gates Rubber Co.; specify length when ordering.

Note. Other fittings may be used as necessary to be compatible with the hot water supply system in use.

3-1.1.3.2 Installation of Fittings to Hot Water Hose. Install fittings in accordance with the following procedures:

WARNING

When installing fittings into hoses, no lubricant other than clean fresh water is to be used.

NOTE

Refer to the appropriate figure and table for subcomponent part numbers prior to assembling any umbilical assembly.

a. Installation of Swage Fittings:

1. Refer to Figures 6-1 through 6-7 and Table 3-5 to determine the fittings required for the hose application.
2. Install swaged fitting to hose as follows:
 - a) Using a sharp blade, cut the hose to the required length. After cutting, the hose end should be square and clean (no nicks, gouges, or other damage).
 - b) Clean the hose bore to remove any loose plastic cuttings.
 - c) Measure the ferrule from the hose entry end of the ferrule to the inner shoulder of the spigot (see Figure 3-1). Measure this distance from the end of the hose and mark it circumferentially.
 - d) Slide spigot into hose until the ferrule reaches the mark made in step c.
 - e) Insert the hose and the ferrule into the crimping machine. Verify that the ferrule is fully inserted into the die.
 - f) Using a suitable 8-finger crimping machine, crimp the ferrule to its finished diameter. See Table 3-6 for dimensions. After crimping the ferrule, verify the spigot bore diameter with a suitably sized tapered go/no-go gauge.

Table 3-6. Hot Water Hose Swage Fitting Dimensions

Manufacturer	Coupling P/N	Swage (post-crimp) Diameter (mm)	Spigot Bore Diameter (mm)
Diveline	JF08SP1F08	26.6 ± 0.1	9.02

- g) Remove the fitting from the crimping machine.

SS521-AH-PRO-010

b. Installation of Barb Fittings (see Figure 3-5):

1. Verify that the hose barb fitting nut is placed over the fitting in the proper orientation for use.

WARNING

When installing fittings into hoses, no lubricant other than clean fresh water is to be used.

NOTE

Refer to the appropriate figure and table for subcomponent part numbers prior to assembling any umbilical assembly.

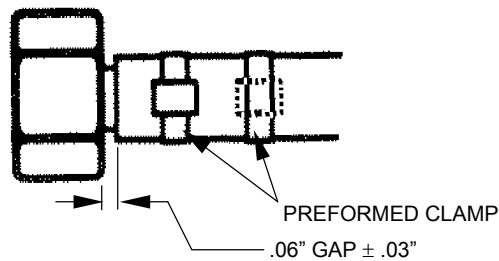

Figure 3-5. Barbed Hose Connection for Hot Water Hose

2. Insert the hose barb into the hose, leaving a gap of $.06'' \pm .03''$ between the end of the hose and the fitting nut.

NOTE

When installing barb-style fittings the hose barb-to-hose connection will be secured with either two or three preformed clamps. If two clamps are used, the buckles will be positioned 180° apart; if three clamps are used the buckles will be positioned 120° apart.

3. Install preformed clamps to secure the hose to the hose barb.

3-1.1.3.3 Pressure Testing Hot Water Hoses.**WARNING**

Never use a gas source for a proof test because of the personnel hazard associated with stored energy from the compressed gas.

NOTE

A proof test is a nondestructive pressure test that is applied to a hose assembly to determine reliability under normal working pressure and to ensure that fittings are installed correctly. As a minimum, the proof test shall be conducted to twice (200%) the maximum system operating pressure. Filtered tap water is typically used as a test medium for DLSS hoses.

- a. Inspect hose to be tested for damage, bulges, swelling, cuts, and abrasions.
- b. Mark the end fitting around its circumference at the point where the fitting meets the hose cover.
- c. Using appropriate fittings, connect the hose to the pressure source.

WARNING

Stand clear of pressurized hoses and fittings while conducting proof testing.

- d. Pressurize the hose to 100 psi or twice the working pressure (whichever is less) and hold the pressure for a minimum of 10 minutes. While pressurized, inspect the hose for swelling, bulges, separation of fitting from the hose, and evidence of leaks. Any of these conditions renders the hose unsatisfactory.
- e. Disconnect the hose from the test assembly and drain it. If the marks have “creeped” more than 1/16” during the course of testing, the hose is unacceptable.
- f. Prior to placing the hose into service, clean the assembly with soap (NID) and water and flush it with fresh water to remove all residual soap and contaminants.

NOTE

Testing of hose assemblies shall be documented in writing as to manufacturer and date of manufacture, testing activity, test date, and proof test pressure. Permanent tags with this information shall be installed on the surface end of the hose assembly.

- g. If the hose is satisfactory, install test tag, showing manufacturer, date of manufacture, test activity, test pressure, and test date.

SS521-AH-PRO-010

3-1.2 COMMUNICATION CABLE INSPECTION, ASSEMBLY, AND TESTING.

The communication fitting that is installed onto the communication cable at the diver's end must be waterproof. The preferred method of construction is to have the fitting molded onto the cable; however, there are several commercial self-curing rubber or epoxy kits that are approved. Encapsulating heat-shrink tubing, installed in layers, over a wire splice or installed connector will also provide a waterproof seal. The fitting at the surface end needs only to be installed in a manner that will prevent undue strain from being applied to the individual wires of the communication cable. The surface end connection will have either a molded connector-to-cable connection or multiple layers of encapsulating heat-shrink tubing at the connection to keep moisture out of the cable assembly.

3-1.2.1 Authorized Communication Cable Assemblies. The following cables listed in Table 3-7 are authorized for use with Navy umbilical assemblies:

Table 3-7. Authorized Communication Cables

Manufacturer/ Supplier/CAGE	Part Number	Notes
JDR Cable (0Y0B0)	CAF0334-(Length in feet)	JDR cable, combination strength/communication, shielded pairs, length and connector ends as specified by ordering activity.
Diveline (3AY00)	CDR010411	Diveline cable, combination strength/communication, shielded pairs, length and connector ends as specified by ordering activity.
AMRON (6S753)	CC1	Communication cable, 2 conductor pair, 20 AWG wire, constructed with shielded pairs, length and connector ends as specified by ordering activity.
JDR (0Y0B0)	CPU04A11	Cable, communication, shielded pairs, length and connector ends as specified by ordering activity.
Consolidated Products (20857)	SB-38784	Cable, shielded pairs – two units, water blocked, length and connector ends as specified by ordering activity.
AMRON (6S753)	DVLCDR010411	Cable, combination strength/communication, shielded pairs, length and connector ends as specified by ordering activity.

3-1.2.2 Waterproof Communication Connectors. On the diver end of the umbilical is a female Marsh Marine Connector. This connects to the male Marsh Marine Connector on the diver's helmet or mask. The electrical connection for these connectors is a 4-pin male to 4-pin female sealed plug assembly (Figure 3-6). Care must be taken to correctly identify the pins and plug holes to prevent incorrect wiring of diver communication microphone and earphones. The electrical connector at the umbilical end is to be wired to match the electrical connections at the diver helmet/mask (see Figures 3-7 and 3-8) to allow proper communications between the surface dive control station, the diver, and other divers in the water.

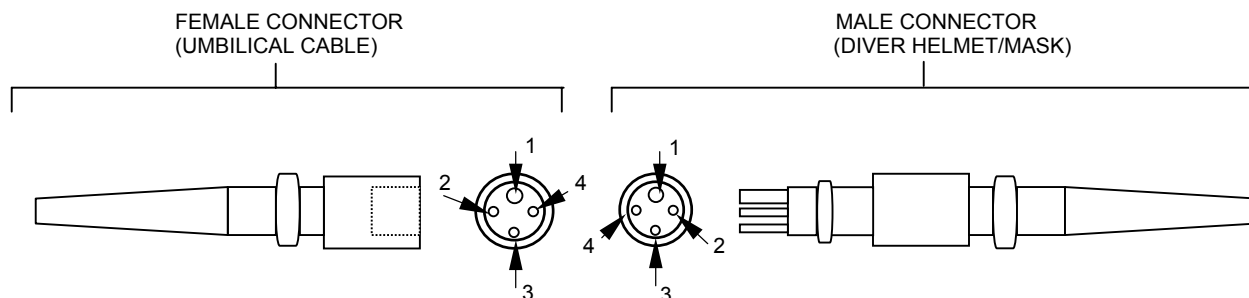

Figure 3-6. Waterproof Male and Female Electrical Connectors

3-1.2.3 Pre-Installation Testing of Communication Cable. The communication cable should be tested prior to assembly as follows:

- a. Visually inspect the communication cable and verify that the insulation is not cut, abraded, or otherwise damaged.
- b. Test the communication cable for continuity. Each wire, when measured from end to end with a multimeter, should be continuous and read a resistance of approximately 1 ohm per 100 feet of length.
- c. Using a megohmmeter, test the resistance from wire to wire and wire to ground within a cable assembly. The resistance from wire to wire or wire to ground should be greater than 1 megohm.

3-1.2.4 Communication Cable Preparation. Prepare the cable for assembly and attachment of the diver end and surface end electrical connectors as follows:

CAUTION

When installing communication cable using multiple shielded wire pairs, the pairs must be soldered to common circuits (i.e., one red-black pair within a shielded section to the headset, and another red-black pair within a shielded section to the microphone). Failure to follow this caution may result in setting up an induced voltage in the cables, resulting in a loud harmonic frequency noise being produced in the diver's headset.

- a. Remove insulation from the communication cable and from each strand of wire on both the communication fitting and cable as required to make the splice.
- b. Lightly sand outer covers of both the communication fitting and cable. Clean the area to be spliced with acetone or alcohol.
- c. Ensure that heat-shrink tubing is placed over the wires to be soldered or spliced and, if used, the inner and outer heat-shrink tubing is placed over the splice and the cable bundle before making the splices.

NOTE

Each segment of encapsulating heat-shrink tubing should extend approximately 1/4 inch over the insulation beyond the stripped conductor of each wire splice. The inner layer of tubing over the splice should extend approximately 1 inch onto both the communication cable and communication fitting insulation covers; the outer layer should extend approximately 1 to 1 1/2 inches each side of the splice (see Figure 3-6).

NOTE

If the insulation cover is manufactured of polyurethane or its equal, a sealer such as PVC pipe sealer must be applied to the covers to ensure bonding.

1. Splice or solder the communication fitting as required. Verify that the headset and microphone assemblies are wired to individual shielded wire pairs.

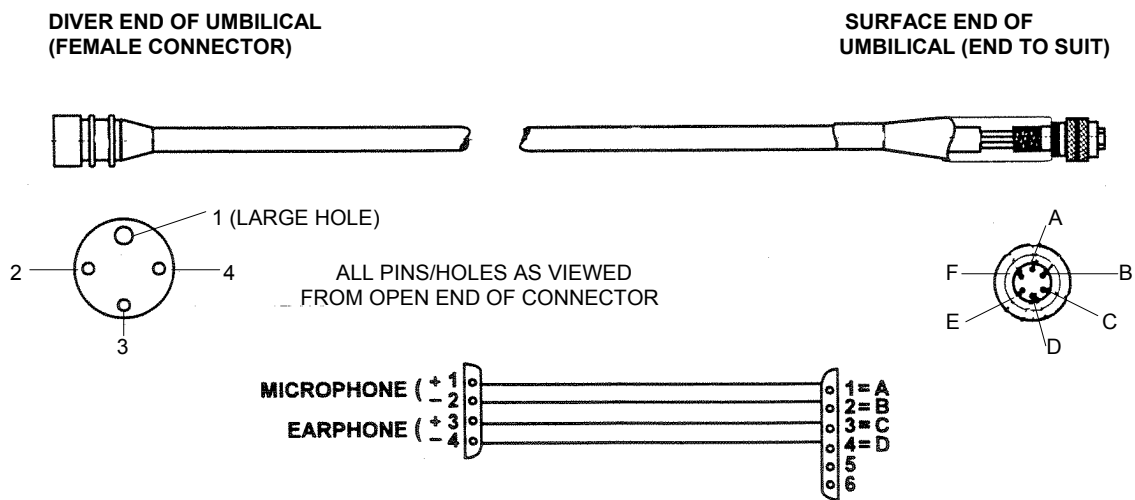

Figure 3-7. Representative Communication Cable Wirings

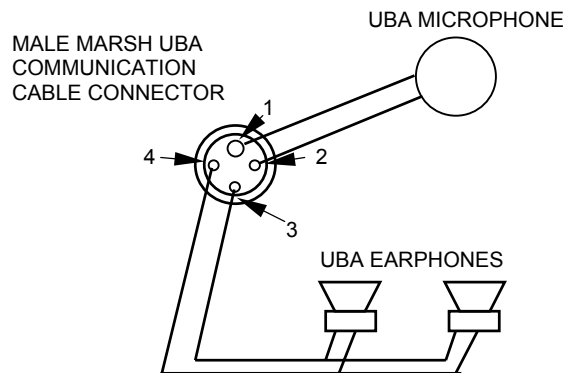

Figure 3-8. Representative UBA Wiring Diagram

2. Insulate each splice by heating the individual conductor's shrink-wrap tube. Inspect each connection to ensure that the tubing has completely sealed around the connection and the conductor and the adjacent insulation, and that it has not melted or sagged to expose the insulation or conductor.

NOTE

If there is a large gap between the communication cable and the communication fitting cable, or if there is a large difference in the sizes, RTV may be used to fill the gap and ensure a waterproof seal. During installation and heating of the heat-shrink tubing, some of the RTV will be extruded, thus ensuring a complete seal at the fitting.

3. Install the inner waterproofing layer of heat-shrink tubing over the splice. The inner layer should extend approximately 1 inch onto both the communication cable and communication fitting insulation covers. Heat the tubing. Inspect the connection to ensure that the tubing has completely sealed around the connection and that it has not melted or sagged to expose the splice.
 4. Install the outer waterproof layer of heat-shrink tubing over the splice. The outer layer should extend approximately 1 to 1 1/2 inches beyond each side of the splice. Heat the tubing. Inspect the connection to ensure that the tubing has completely sealed around the connection and the adjacent insulation and that it has not melted or sagged to expose the inner waterproofing layer of heat-shrink tubing.
- d. If using poured resin or casting, proceed as follows:

NOTE

For poured or cast resin fittings or repairs, a two-part epoxy system such as Hapflex 595 parts A and B (or equivalent) may be used. Follow the manufacturer's instructions for preparation, construction of the mold, application of mold release agent, and application of the epoxy.

1. Splice or solder the communication fitting as required. Verify that the headset and microphone assemblies are wired to individual shielded wire pairs
2. Insulate each spliced or soldered connection by heating the individual conductor's shrink-wrap tube. Inspect each connection to ensure that the tubing has completely sealed around the connection, the conductor, and the adjacent insulation, and that it has not melted or sagged to expose the insulation or conductor.
3. Obtain the two-part epoxy casting material to complete the casting.
4. Following the manufacturer's instructions, prepare the splice and connector.

SS521-AH-PRO-010

5. Form the mold for the joint to be repaired.
 6. Following the manufacturer's instructions, mix the appropriate resin and hardener and apply the mixture to the mold.
 7. Allow the casting to cure; remove the mold.
- e. Test the communication cable for continuity. Each wire, when measured from end to end with a multimeter, should be continuous and read a resistance of approximately 1 ohm per 100 feet of length.
 - f. Using a megohmmeter, test the resistance from wire to wire and wire to ground within a cable assembly. The resistance from wire to wire or wire to ground should be greater than 1 megohm.

3-1.3 TESTING D-RING AND SHACKLE ASSEMBLIES

If, during assembly, the D-ring is cut and welded to install the snap shackle, then the D-ring must be weight tested to a 500-pound static load prior to installing the D-ring and shackle assembly to the umbilical assembly. To test the D-ring proceed as follows:

NOTE

If procured as a shackle and D-ring assembly from the original manufacturer, the D-ring need not be load tested.

- a. Inspect hardware to be tested for damage, deformation, and cracks.
- b. Mark, measure and record the major dimensions of the D-ring (length, width, and wire diameter).
- c. Using appropriate rigging hardware, attach a 500-pound dead weight and a lifting hardware along the major axis (length) of the D-ring .
- d. Lift the dead weight three to four inches off the floor and allow it to remain suspended for ten minutes.
- e. Lower the dead weight and disconnect the D-ring from the dead weight and lifting hardware.
- f. Compare the measurements from step b. above and inspect the D-ring for cracks, deformation, and other damage. If the measurements have changed appreciably, or if damage is visible, discard the D-ring.

3-1.4 SEIZING HOSES AND FITTINGS.

Seize hose assemblies and fittings to the assemblies as follows:

NOTE

For spiral-wound umbilical assemblies, seizing is only required at the diver end and surface end D-rings. The remainder of the assembly derives its strength from its spiral-wound construction.

NOTE

When seizing strength members or combined communication/ strength cables to the D-rings, 3/16" nylon cord must be used. Other seizings along the length of the umbilical assembly may be nylon cord, Polyken tape, duct tape, or 3/16" marline.

3-1.4.1 Seizing D-Rings to Umbilical Assembly. To seize the D-ring to the umbilical assembly proceed as follows:

NOTE

If, during repair or assembly, the D-ring and shackle assembly have been welded or otherwise altered, or if not procured from the original manufacturer as a D-ring and shackle assembly, then the D-ring must be pull tested to 500 pounds and support the weight for a minimum of 10 minutes without distortion, bending, or other damage. Any welding and subsequent pull testing shall be conducted prior to the attachment of the D-ring to the umbilical assembly. See section 3-1.3 for test requirements and procedure.

- a. Verify that the D-ring and shackle assembly was either procured as an assembly or has been welded and tested in accordance with section 3-1.3.
- b. Splice the strength member (3/8" synthetic double braid line) onto the D-ring with a soft eye, if required.
- c. Lay umbilical assembly on a flat work surface. Pressurize hoses to normal working pressures to allow for hose growth along their length and diameter.
- d. Measure and mark the required length from the end of the pneumofathometer hose, breathing gas hose, hot water hose (if required), and communications cable (or communication cable/strength member, as applicable). Refer to Figures 6-1 through 6-8 for dimensions.
- e. Place D-ring at the reference mark. See Figure 3-9.

SS521-AH-PRO-010

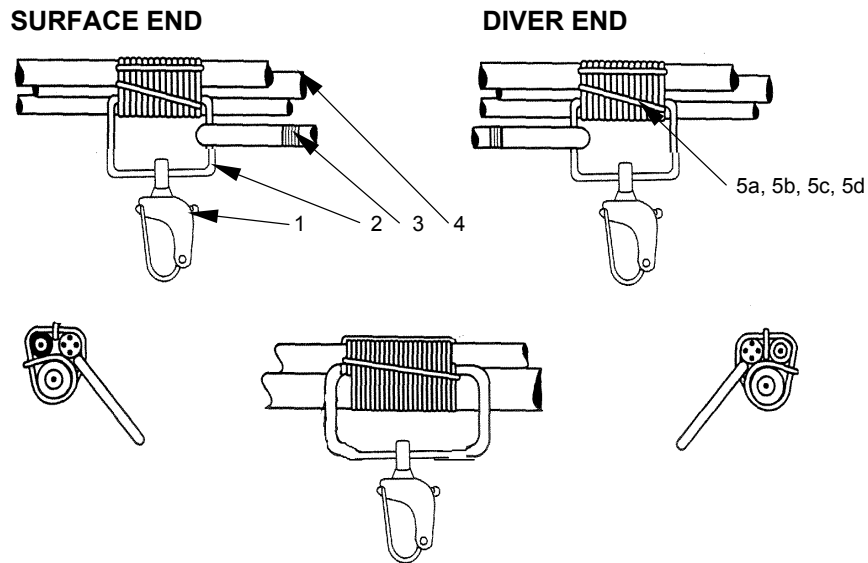

Figure 3-9. Seizing D-Ring to Umbilical Assembly

- f. Using 3/16" nylon cord (Table 3-8, item -5a), seize the D-ring to the umbilical assembly as follows. See Figure 3-9.

Table 3-8. Seizing Materials List

Fig./Index Number	CAGE Code	Part Number/ NSN	Description	Qty	Notes	
1-1	6D887	110000S	Shackle, snap, or equivalent	1	1	
	81348	4030-01-324-4866				
	14819	11000FR	Shackle, snap, or equivalent		1,3	
	81348	4030-01-321-6008				
-2	6S753	45-10D	Shackle, snap, w/ welded D-ring	2		
	14819	DR11	D-ring, 1/4" diameter, stainless steel			
	6S753	HB174	D-ring, 3/8" diameter, stainless steel			
-3	81348	4020-00-946-0436	Double braid 3/8" synthetic line, or equivalent	AR		
-4	Various	VARIOUS	Umbilical hoses; refer to figures in section 6 to determine hoses for each assy.	AR		
-5a	1G359	266050	Cord, nylon, 3/16", or equivalent	AR	2	
	81348	4020-00-240-2146	NSN			
-5b	1G359	T-R-650 TY 4 CL 1	Cord, marline 3/16", or equivalent	AR	2	
	81348	4020-00-240-2185	NSN			
-5c	79130	398-2 + color	Tape, duct or equivalent	AR	2	
-5d	80769	827-2	Tape, diver umbilical, 2 in. x 36 yds or equivalent	AR		

Notes:

- 1 Snap shackle is required on diver end but is optional on surface end.
- 2 Items 5b, 5c, and 5d are not authorized for seizing the D-ring to the umbilical assembly. These items may be used on all other seizings on the umbilical assembly.
- 3 Use of this snap shackle and D-ring assembly eliminates part -2 of this assembly on the affected end.

CAUTION

When seizing the D-ring to the umbilical assembly, wraps must be tight, but care must be taken to ensure that the pneumofathometer hose, breathing gas hose, and communication cable are not crushed or pinched.

NOTE

Hoses should be pressurized to normal system pressure while seizing to account for the expansion required during operation.

1. Lay out the D-ring at the reference mark at one end of the umbilical assembly.
2. Place the seizing cord along the strength member, making a loop approximately 4" long with the free end of the seizing cord over the D-ring.
3. Wrap the cord tightly around the umbilical assembly, passing the cord in alternating directions over the D-ring to ensure that when installed the D-ring will not slip.
4. Complete wrapping the nylon cord over the assembly to fill the D-ring.
5. Bring the free end of the seizing cord and place it through the loop made in step 2. above. Pull the free end of the cord to close the loop and draw the bitter end under the seizing.
6. Using a sharp knife, cut the seizing cord at each end of the wrapping. Ensure that while cutting the cord the hoses and communication cable are not damaged.
7. Finish the seizing by wrapping the completed assembly with two layers of Polyken (preferred) or duct (alternate) tape.

3-1.4.2 Seizings Subsequent to D-Ring End Fittings. Subsequent to the end D-ring fittings, the following procedures are to be used to marry the hoses together over the length of a parallel (taped) umbilical assembly.

NOTE

Seizings along the umbilical assembly's length between the D-rings on a parallel (taped) umbilical assembly are not structural fittings. Therefore, items 5a, 5b, 5c, or 5d from Table 3-8 may be used to marry the umbilical components into a single assembly.

- a. Seizing the assembly with marline or nylon seizing cord.

SS521-AH-PRO-010

CAUTION

When seizing the umbilical assembly, wraps must be tight, but care must be taken to ensure that the pneumofathometer hose, breathing gas hose, and communication cable are not crushed or pinched.

NOTE

Hoses should be pressurized to normal system pressure while seizing to account for the expansion required during operation.

NOTE

If the umbilical assembly has a combined strength/ communication cable, a cable grip must be used on the cable to ensure that an even, straight pull is applied to the cable.

1. Place the strength member under light tension (not to exceed 100 pounds line pull) to allow easy assembly of the remaining components.
2. Starting 1 inch from the diver end D-ring, mark the strength member at 12- to 18-inch intervals for the first 50 feet of the umbilical. The same seizing intervals are required for the last 50 feet of umbilical (up to the surface end). For the remaining length of the umbilical, seize the assembly at intervals, as required by the user, but not to exceed 36 inches.

REPAIR NOTE

In the event of an in-service communication cable failure, a provisional (replacement) communication cable may be wrapped around the breathing gas hose and taped in place without removing the original communication cable. This allows the replacement of the failed communication cable without disassembly of the umbilical.

3. Lay out the umbilical components along the strength member.

NOTE

During the assembly process, care must be taken to ensure that there are no loops in the hoses, strength member (if used), or communication cable.

4. Starting at the diver end of the umbilical, seize the assembly along its length at the marked points from step 2. above. Seize the assembly following the procedure outlined in section 3-1.4.1, step f. The length of each finished seizing will be a minimum of 2 inches.

- b. Seizing with Polyken or duct tape. Seize the umbilical assembly (parallel construction umbilical) between the structural seizings at the D-rings in accordance with the following procedure:

NOTE

For non-structural seizing with tape, Polyken is the preferred material. Duct tape is an approved alternate material. While using either material, the seizing is to be made using a continuous segment of tape.

NOTE

If the umbilical assembly has a combined strength/communication cable, a cable grip must be used on the cable to ensure that an even, straight pull is applied to the cable.

1. Place the strength member under light tension (not to exceed 100 pounds line pull) to allow easy assembly of the remaining components.
2. Starting 1 inch from the diver end D-ring, mark the strength member at 12- to 18-inch intervals for the first 50 feet of the umbilical. The same seizing intervals are required for the last 50 feet of umbilical (up to the surface end). For the remaining length of the umbilical, seize the assembly at intervals as required by the user, but not to exceed 36 inches.

REPAIR NOTE

In the event of an in-service communication cable failure, a provisional (replacement) communication cable may be wrapped around the breathing gas hose and taped in place without removing the original communication cable. This allows the replacement of the failed communication cable without disassembly of the umbilical.

3. Lay out the umbilical components along the strength member.

NOTE

During the assembly process, care must be taken to ensure that there are no loops in the hoses, strength member (if used), or communication cable.

4. Starting at the diver end of the umbilical, seize the assembly along its length at the marked points from step 2. above.
5. Starting at the first mark behind the D-ring, wrap the strength member with 2 layers of tape. **DO NOT CUT THE TAPE.**
6. Place the breathing gas hose alongside the strength member, and continue with 4 more wraps of tape. **DO NOT CUT THE TAPE.**

SS521-AH-PRO-010

7. If the communication cable is separate from the strength member, place the cable alongside the breathing gas hose and wrap them with 2 more wraps of tape. **DO NOT CUT THE TAPE.**
8. Place the pneumofathometer hose and communication cable (if separate) alongside the strength member, and continue with 4 more wraps of tape. **CUT THE TAPE.**
9. Continue at the next mark on the strength member and assemble and seize the umbilical. Seize the umbilical assembly components using tape until reaching the mark for the surface end D-ring.

3-1.5 UMBILICAL ASSEMBLY CHAFING PROTECTION. If desired by the procuring command, a 50-foot chafing cover may be installed over the diver's end of the umbilical assembly. The chafing cover is placed over the umbilical assembly and installed using integral Velcro™ strips sewn into the edges of the cover. These are available commercially and a representative part number is given (see Table 3-9). Additionally, the chafing cover is secured to the assembly by taping it over the umbilical to prevent it from riding up over the assembly.

Table 3-9. Chafing Cover Part Numbers

CAGE Code	Part Number	Description
Mar-Vel (14819)	AQPC-50-YLW	Cover, umbilical, yellow, 50 ft
	AQPC-50-RED	Cover, umbilical, red, 50 ft
	AQPC-50-GRN	Cover, umbilical, green, 50 ft
Amron (6S753)	UMB-SH-50-RED	50-ft umbilical sheath, red
	UMB-SH-50-GRN	50-ft umbilical sheath, green
	UMB-SH-50-YEL	50-ft umbilical sheath, yellow

3-2 ASSEMBLING THE UMBILICAL.

Assemble the umbilical as described in the following procedures:

3-2.1 ASSEMBLY OF A 3-PART UMBILICAL. 3-part umbilicals with a double braid strength member shall be assembled as follows:

- a. Assemble tested components with end fittings installed according to the procedures outlined in sections 3-2.2 or 3-2.3.

NOTE

If, during repair or assembly, the D-ring and shackle assembly have been welded or otherwise altered, or if not procured from the original manufacturer as a D-ring and shackle assembly, then the D-ring must be pull tested to 500 pounds and support the weight for a minimum of 10 minutes without distortion, bending, or other damage. Any welding and subsequent pull testing shall be conducted prior to the attachment of the D-ring to the umbilical assembly. See section 3-1.3 for test requirements and procedure.

CAUTION

At no time during assembly should the communication cable be put under stress unless it is a combination strength/communication cable.

REPAIR NOTE

In the event of an in-service communication cable failure, a provisional (replacement) communication cable may be wrapped around the breathing gas hose and taped in place without removing the original communication cable. This allows the replacement of the failed communication cable without disassembly of the umbilical.

- b. Splice the strength member to the diver end D-ring. Mark and seize the diver end breathing air hose, pneumofathometer hose, and communication cable to the strength member according to section 3-1.4.1.
- c. Mark and make the subsequent seizings according to section 3-1.4.2.
- d. Mark and splice the strength member to the surface end D-ring.
- e. Seize the surface end breathing air hose, pneumofathometer hose, and communication cable to the strength member, according to section 3-1.4.1.
- f. Verify the dimensions as required by the command for the surface end free hose and cable specifications (see Figures 6-1 through 6-7 and Tables 6-1 through 6-7).
- g. Verify that test tags are properly installed and that certification paperwork is included with the umbilical assembly.
- h. If requested by the end user, install chafing protection sleeve onto the umbilical assembly.

3-2.2 ASSEMBLY OF A 3-PART UMBILICAL WITH COMBINED STRENGTH/COMMUNICATION CABLE. 3-part umbilicals with a combined strength/communication cable shall be assembled as follows:

- a. Assemble tested components with end fittings installed according to the procedures outlined in section 3-2.

NOTE

If, during repair or assembly, the D-ring and shackle assembly have been welded or otherwise altered, or if not procured from the original manufacturer as a D-ring and shackle assembly, then the D-ring must be pull tested to 500 pounds and support the weight for a minimum of 10 minutes without distortion, bending, or other damage. Any welding and subsequent pull testing shall be conducted prior to the attachment of the D-ring to the umbilical assembly. See section 3-1.3 for test requirements and procedure.

SS521-AH-PRO-010**CAUTION**

At no time during assembly should the communication cable be put under stress unless it is a combination strength/communication cable.

REPAIR NOTE

In the event of an in-service communication cable failure, a provisional (replacement) communication cable may be wrapped around the breathing gas hose and taped in place without removing the original communication cable. This allows the replacement of the failed communication cable without disassembly of the umbilical.

- b. Mark and seize the diver end strength member/communication cable, D-ring, breathing air hose, and pneumofathometer hose according to section 3-1.4.1.
- c. Mark and seize the subsequent seizings according to section 3-1.4.2.
- d. Seize the surface end strength member/communication cable, D-ring, breathing air hose, pneumofathometer hose, and hot water hose (if installed) according to section 3-1.4.1.
- e. Verify the dimensions as required by the command for the surface end free hose and cable specifications (see Figures 6-1 through 6-7 and Tables 6-1 through 6-7).
- f. Verify that test tags are properly installed and that certification paperwork is included with the umbilical assembly.
- g. If requested by the end user, install chafing protection sleeve onto the umbilical assembly.

3-2.3 ASSEMBLY OF A 3-PART SPIRAL-WOUND UMBILICAL. Spiral-wound umbilicals are procured by the fabricator in bulk lengths of pre-wound assemblies. The assembly is measured and cut from the stock material and the end fittings are attached as requested by the end user. To fabricate a 3-part spiral-wound umbilical, proceed as follows:

- a. Verify the requested overall length of the finished umbilical assembly. Measure and mark the components to include positioning of the diver and surface end D-rings.

REPAIR NOTE

In the event of an in-service communication cable failure, a provisional (replacement) communication cable may be placed in the umbilical grooves and taped in place without removing the original communication cable. This allows the replacement of the failed communication cable without disassembly of the umbilical.

NOTE

If, during repair or assembly, the D-ring and shackle assembly have been welded or otherwise altered, or if not procured from the original manufacturer as a D-ring and shackle assembly, then the D-ring must be pull tested to 500 pounds and support the weight for a minimum of 10 minutes without distortion, bending, or other damage. Any welding and subsequent pull testing shall be conducted prior to the attachment of the D-ring to the umbilical assembly. See section 3-1.3 for test requirements and procedure.

CAUTION

At no time during assembly should the communication cable be put under stress unless it is a combination strength/communication cable.

- b. Cut the umbilical components from the bulk storage reel.
- c. Attach the approved fittings on the diver's air hose, pneumofathometer hose, and communication cables. See section 3-1.1.
- d. Test the breathing air hose and fittings in accordance with section 3-1.1.1.3.
- e. Test the pneumofathometer hose and fitting in accordance with section 3-1.1.2.3.
- f. If required, cut the diver end D-ring install the diver end shackle. Weld the D-ring. Load test the D-ring with 500 pounds of dead weight. The D-ring shall not be deformed or damaged as a result of the load test.
- g. Seize the diver and surface end D-rings onto the umbilical assembly at the marks from step a. above in accordance with section 3-1.4.1.
- h. Verify the dimensions as required by the command for the surface end free hose and cable specifications (see Figures 6-1 through 6-7 and Tables 6-1 through 6-7).
- i. Verify that test tags are properly installed and that certification paperwork is included with the umbilical assembly.
- j. If requested by the end user, install chafing protection sleeve onto the umbilical assembly.

3-2.4 ASSEMBLY OF A MULTI-PART UMBILICAL. Multi-part umbilicals (umbilicals incorporating hot water hoses, camera cables, lighting cables, or other components) shall be assembled in the same manner as 3-part assemblies.

SS521-AH-PRO-010

4-1 ORDERING UMBILICAL ASSEMBLIES.

In all cases, it is the responsibility of the end user or ordering command to determine the length of the umbilical assembly and the type of fittings required prior to ordering. When ordering the umbilical assembly or subcomponents, the end user of the umbilical must specify how the umbilical is to be assembled. The procedures below show how a diving umbilical can be developed to meet specific user requirements.

4-1.1 DETERMINING SPECIFICATIONS.

Determine the specification for the system to be used prior to ordering umbilical assemblies or subcomponents. From the following sections, the Umbilical Ordering Worksheet (Appendix A) can be filled out.

4-1.2 DETERMINING THE REQUIRED SUBCOMPONENTS.

- a. Identify the diving mask/helmet to be used.
- b. Identify the length of umbilical required for operations.
- c. Verify the fittings required on the breathing air, pneumofathometer, and accessory hoses. The standard fittings for the breathing air and pneumofathometer hoses are 9/16-18 oxygen fittings. If installed, the hot water hose will have fittings compatible with the end user's hot water supply system.
- d. Determine the pressure requirements for the breathing gas and pneumofathometer hoses. This will be used to determine the testing requirements for the hose assemblies (see Tables 3-1 and 3-3).
- e. Identify the type of communication connectors required. This will be either the Marsh or telephone connectors. If the command uses both systems, then communication adapters will be required.
- f. D-ring: required at both surface and diver end of assembly.
- g. Snap shackle: determine the number and location of snap shackles required. A snap shackle is required on the diver end, but is optional on the surface end of the assembly. If the D-ring is cut and welded to install the snap shackle, then the D-ring must be load tested (see section 3-1.3).
- h. Umbilical type; spiral-wound or parallel construction:
 1. If spiral-wound assembly is ordered, a strength member is not required. In addition, the assembly will be seized only at the surface and diver end D-rings.

2. If parallel assembly is ordered, either a combined communication cable/ strength member or a separate strength member will be required. The assembly will be seized at the surface end and diver end. In addition, the assembly will be seized over its length as described in section 3-1.4 of this manual.
- i. Certification and marking: the assembly will be accompanied with certification paperwork and the hoses will have permanently installed tags showing the manufacturer, date of manufacture, test date, test pressure, tester, and location of the test facility.

4-1.2.1 Example of Umbilical Assembly to Be Ordered. Using the above information, the subcomponents for an umbilical assembly may be determined using the following suggested umbilical worksheet.

EXAMPLE: A dive locker wishes to obtain a 300' 3-part spiral umbilical for use with a Mk 21 helmet. See Figure 4-1 and the following explanatory page which show how this umbilical might be configured and ordered.

SS521-AH-PRO-010

Brief description of assembly: <i>Mk 21, 300' spiral-wound umbilical assembly</i>		Type of mask/helmet Circle one: Mk 20 Mk 21	
		Umbilical construction Circle one: Spiral Parallel	
Component	Test Requirements	Notes	CAGE Code
			Part Number/ Dimension
Breathing air hose: <u>300</u> ' overall length (4)	Hydrostatic test to 750 psi or twice working pressure (whichever is less). Lower pressure and load/pressure test at 500-psi/200-lb dead weight.	Requires 9/16-18 oxygen fitting each end. May be swage or barb-style fitting.	ABC00 (5)
			XXX0106 (6)
Pneumofathometer hose: <u>300</u> ' overall length (7)	Hydrostatic test to 200 psi.	Requires 9/16-18 oxygen fitting on surface end. May be swage or barb-style fitting.	ABC00 (8)
			XXX0104 (9)
Strength member required (10) YES NO		Not required on spiral construction. May be either separate strength member or combined communication/ strength member.	(11)
			(12)
Communication cable: <u>300</u> ' overall length (13)	Check continuity: end-to-end – approx. 1 ohm/100' Check resistance: wire-to-wire/ground – greater than 1 megohm	May be combined strength/ communication cable as required. See section 6.	ABC00 (14)
			CPU 0411A (15)
Comm cable diver end fitting		Refer to Mk 20 and Mk 21 technical manual.	ABC00 (16)
			WP-4-FS (17)
Comm cable surface end fitting		As required by end user communication system.	(18)
			(19)
Snap shackle		Required at diver end; optional at surface end.	ABC00 (20)
			11000FR (21)
D-ring	Load test to 500-lb dead weight if cut and welded to install shackle.	Required at surface end and diver end of assembly.	ABC00 (22)
			HB176 (23)
Required length from diver end seizing: Diver air hose Pneumo hose Comm cable		See figures in section 6 for required lengths.	(24)
			12 ± 2" 18" 12"
Required length from surface end seizing: Diver air hose Pneumo hose Comm cable		As required by end user.	(25)
			72" 72" 72"
Seizing (26) YES		Seizing as required by section 3-1.4 of manual.	
Test tags installed (27) YES	Test tags to show test date, test pressure, tester, and location of test.	Required on diver air hose, pneumofathometer hose, and hot water hose (if installed).	
Builder certificate required (28) YES	Show manufacturer name, manufacture date, test date, test pressures, and test location.	Required on all Navy hoses.	
Other accessory components	As requested by end user.	Add camera, hot water hoses as indicated by section 3-2.4 of manual.	NA
			NA

Figure 4-1. Umbilical Ordering Worksheet

Block 1: Brief description of assembly.

Block 2: Type of mask/helmet. Circle Mk 21.

Block 3: Umbilical construction. Circle Spiral.

Block 4: Enter length of breathing air hose.

Blocks 5 and 6: Fill in CAGE code and part number. The chart gives the specifications for pressure and load testing and tells the manufacturer what fittings are required on the hose.

Block 7: Enter length of pneumofathometer hose.

Blocks 8 and 9: CAGE code and part number. The chart gives the specification for pressure testing and tells the manufacturer what fittings are required.

Block 10: Strength member required; Circle YES or NO.

Blocks 11 and 12: Fill in CAGE code and part number of strength member.

Block 13: Enter length of communication cable.

Blocks 14 and 15: CAGE code and part number. The chart gives test specifications for the cable.

Blocks 16 and 17: Fill in CAGE code and part number for diver end cable connector.

Blocks 18 and 19: Fill in CAGE code and part number for surface end cable connector.

Blocks 20 and 21: Fill in CAGE code and part number for snap shackle. The chart gives the location of the required shackle.

Blocks 22 and 23: Fill in CAGE code and part number. The chart gives test requirements.

Block 24: Fill in dimensions from figures in section 6.

Block 25: Fill in dimensions from figures in section 6.

Block 26: Circle YES to have umbilical seized IAW section 3-1.4.

Block 27: YES, all hoses require test tag to be installed.

Blocks 28: YES, all hoses require certification paperwork.

SS521-AH-PRO-010**4-1.3 SPECIFICATIONS FOR THE FABRICATOR.**

- a. Communication cables must meet resistance and continuity specifications. In addition, specific wiring cautions must be adhered to when assembling the communications cable. Refer to section 3-1.2 for details.
- b. All fittings must be as specified and compatible with Approved for Navy Use Diver Life Support Systems.
- c. General requirements for umbilical procurement must include the required pressure and strength testing of the pneumofathometer and breathing gas hoses. In addition, swaged fittings and load bearing members must pass physical load testing. Refer to sections 3-1 and 3-2 for assembly, proof testing, load testing, and cleaning requirements.
- d. Upon completion of testing, all pressure-rated components must have permanently installed tags showing the manufacturer, date of manufacture, test date, test pressure, and location of test facility. In addition, certification documents showing the above information must accompany the umbilical assembly or components.
- e. After the prerequisite testing, the components are to be assembled either by being twisted into the spiral configuration (i.e., the individual components woven together as in the Aqualite assembly) or married together into an umbilical assembly. Follow the manufacturer's procedures and section 3-1.4 to marry the components into the assembly.
- f. If required, install chafing protection on the umbilical assembly.

4-1.4 RECEIPT INSPECTION.

Upon receiving the umbilical assembly, the end user will verify the following.

- a. All certification paperwork is included with the umbilical assembly or components.
- b. All installed fittings are compatible with Approved for Navy Use Diver Life Support Systems.
- c. All pressure-rated components have the required permanently installed certification tags.
- d. Visually inspect the umbilical assembly for proper assembly, damage, and serviceability.

4-2 COMMUNICATION ADAPTERS AND HOSE ADAPTER WHIPS APPROVED FOR NAVY USE.

Figure 4-2 and Tables 4-1 and 4-2 provide CAGE Codes, part numbers, descriptions, and notes for the hose and communication adapters that are Approved for Navy Use (ANU).

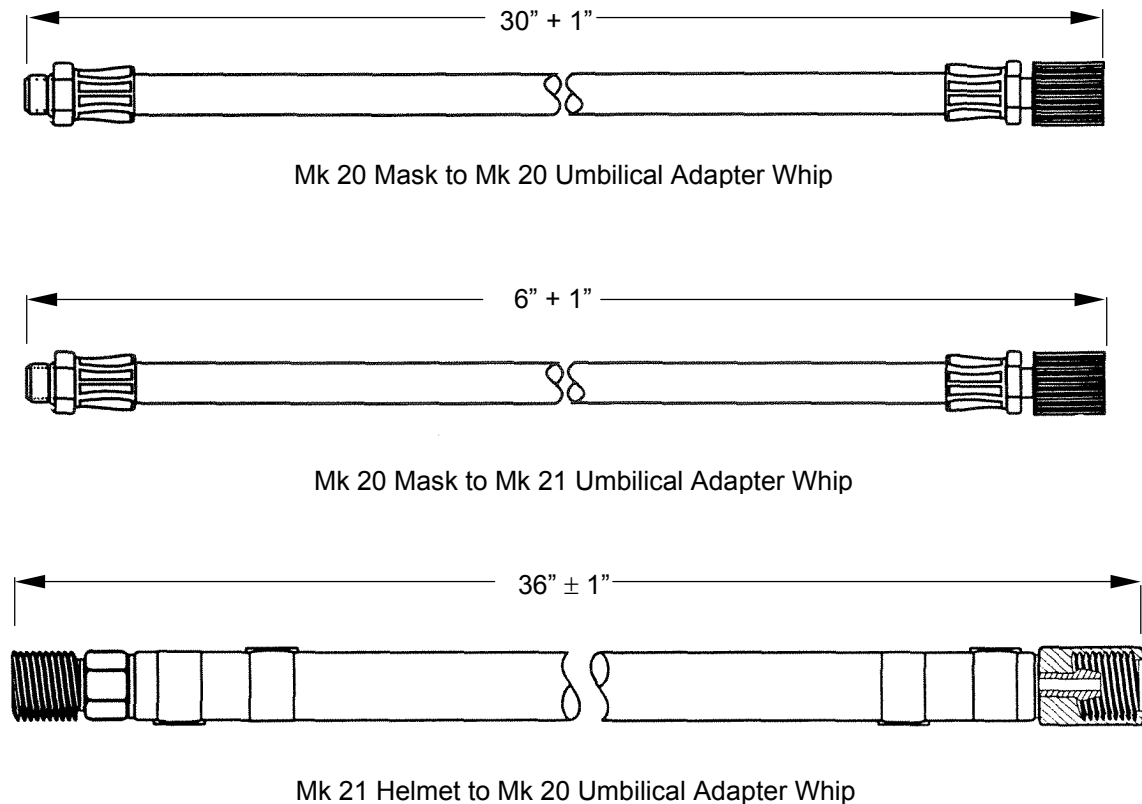

Figure 4-2. UBA to Umbilical Hose Adapters

Table 4-1. Part Numbers for UBA to Umbilical Hose Adapters

CAGE Code	Part Number	Description	Notes
6S753	LPAGA02A30	Mk 20 Mask to Mk 20 UBA Hose Whip	5/16" ID hose, 30" overall length
OGM59	10313	Mk 20 Mask to Mk 20 UBA Hose Whip	5/16" ID hose, 30" overall length
14819	E227A10313	Mk 20 Mask to Mk 20 UBA Hose Whip	5/16" ID hose, 30" overall length
6S753	LPAGA02A6	Mk 20 Mask to Mk 21 UBA Hose Whip	5/16" ID hose, 6" overall length
14819	LPF-06	Mk 20 Mask to Mk 21 UBA Hose Whip	5/16" ID hose, 6" overall length
6S753	HA-0193	Mk 21 Helmet to Mk 20 UBA Hose Whip	3/8" ID hose, 36" overall length
OGM59	6670541	Mk 21 Helmet to Mk 20 UBA Hose Whip	3/8" ID hose, 36" overall length

SS521-AH-PRO-010

Table 4-2. Umbilical Communication Cable Adapters

CAGE Code	Part Number	Description	Notes
6S753	6817177	Mk 20 to Mk 21 umbilical adapter	6-cable w/ female Nexus connector and male Marsh Marine connector. Adapts Mk 20 mask to Mk 21 umbilical.
6S753	DC5CM-1	Mk 20 communication module connector	Male Nexus connector, w/ AWG 24 wire. Normally spliced to Mk 20 communication connector.
6S753	DC5CF-1	Mk 20 umbilical connector	Female Nexus connector, AWG 24 cable. Normally spliced to diver end of Mk 20 umbilical cable.
6S753	2400-007	Mk 20 adapter / Mk 21 adapter	Adapter from MS connector to dual pin banana plug.
6S753	6817175	Mk 21 helmet to Mk 20 umbilical adapter	32-cable with male Nexus connector and female Marsh Marine connector. Adapts Mk 21 helmet to Mk 20 umbilical.
90129	WP-4-FS	Female waterproof connector	4-pin female Crouse-Hinds WP connector, 18", 18-SJO conductors.
90129	WP-4-MP	Male waterproof connector	4-pin male Crouse-Hinds WP connector, 18", 18-SJO conductors.

5-1 VENDOR CAGE CODES.

Table 5-1 shows a list of vendors and their CAGE Codes.

Table 5-1. Vendors and CAGE Codes

CAGE Code	Vendor / Address / Phone Number
0GM59	Divers Supply Inc. 2396 Chasse Highway Gretna, LA 70054 (504) 392-2800
0X660	Eaton Aeroquip Inc., Industrial Connector Division 1225 W. Main Street Van Wert, OH 45891-9362 (419) 238-1190
0Y0B0	JDR Cable Systems Inc. 6225 Sam Houston Parkway N. Houston, TX 77041 (713) 466-6821
0YFD5	Norman S. Wright and Company, DBA Nicro Marine 2065 W. 140th Avenue San Leandro, CA 94577 (510) 357-8332
1G359	Sampson Ocean Systems Inc. 2090 Thornton Street Ferndale, WA 98248-9314 (206) 384-4669
14819	Mar-Vel International 7100 Airport Highway Pennsauken, NJ 08109 (800) 325-5711

Table 5-1. Vendors and CAGE Codes (contd)

CAGE Code	Vendor / Address / Phone Number
24161	The Gates Corporation, A Division of the Gates Rubber Company 990 S. Broadway PO Box 5887 Denver, CO 80217-5887 (303) 744-1911
20857	South Bay Cable Corporation 54125 Maranatha Drive Idyllwild, CA 92549 (909) 659-3958
3AY00	Diveline Incorporated 4755 Alpine Drive, Suite 100 Stafford, TX 77477 (281) 240-5450
3WYX8	Hapco Inc. 353 Circuit Street Handover, MA 02339 (781) 826-8801
6D887	Paxton Company 1111 Ingleside Road Norfolk, VA 23502 (800) 853-7709
6S753	Amron International 759 W. 4th Ave. Escondido, CA 92025 (760) 746-3834
70847	Band-It-Idex Inc., Unit of IDEX Corp. 4799 Dahlia St. PO Box 16307 Denver, CO 80216 (303) 320-4555
79130	Nashua Corporation, Industrial Tape Division 2600 7th Avenue Watervliet, NY 12189 (518) 271-2200
80769	Polyken Technologies, Division of the Kendall Company 15 Hampshire Street Mansfield, MA 02048 (508) 261-6200
81348	Federal Specifications Promulgated by the General Services Administration, Washington, DC
85757	Saint-Gobain Performance Plastics Company 1199 S. Chillicothe Road Aurora, OH 44242 (330) 562-9111
90129	Cooper Industries Inc., Crouse-Hinds Division 4758 Washington Street La Grange, NC 28551 (713) 209-8400

SS521-AH-PRO-010**6-1 COMPONENTS AND SUBCOMPONENTS APPROVED FOR NAVY USE.**

Figures 6-1 through 6-8 and Tables 6-1 through 6-8 give the components and subcomponents used in constructing umbilical assemblies. The part numbers, CAGE codes, and notes define the dimensions and allowable items used in construction of the assemblies.

6-1.1 PARTS LIST COLUMN DEFINITIONS.

The principal component parts lists (Tables 6-1 through 6-8) are divided into multiple columns to enhance operator/maintainer referencing. Individual column explanations are given in the following sections.

- a. Fig./Index Number. The figure number identifies the number of the illustration in which the item is shown. The index number identifies individual items in the illustration.
- b. CAGE Code. The Commercial and Government Entity (CAGE) code is a five-digit numeric code, listed in SB 708-42, which identifies the manufacturer of the component/part.
- c. Part Number. This column lists the number used by the manufacturer (individual, company, firm, corporation, or Government activity) that controls the design and characteristics of the item by means of engineering drawings, specifications, standards, and inspection requirements, to identify an item or range of items.
- d. Description. The description indicates the Federal item name and, if required, a minimum description to identify the item. Items included in kits and sets are listed below the name of the kit or set with the quantity of each item indicated in the unit column. When the part used differs among serial numbers of the same model, the effective serial numbers are shown as the last line of the description.
- e. Qty. This column indicates the quantity of the item shown on the illustration or figure that is prepared for a functional group, sub-functional group, or an assembly. An AR (as required) appearing in this column in lieu of a quantity indicates that no specific quantity is applicable. This designation applies to items such as seizing cord, tape, and clamps, which are used as required.
- f. Notes. This gives numerical references to notes located below the table. These notes give specific dimensional requirements, exclusions, or use requirements, where applicable.

THIS PAGE INTENTIONALLY LEFT BLANK.

SS521-AH-PRO-010

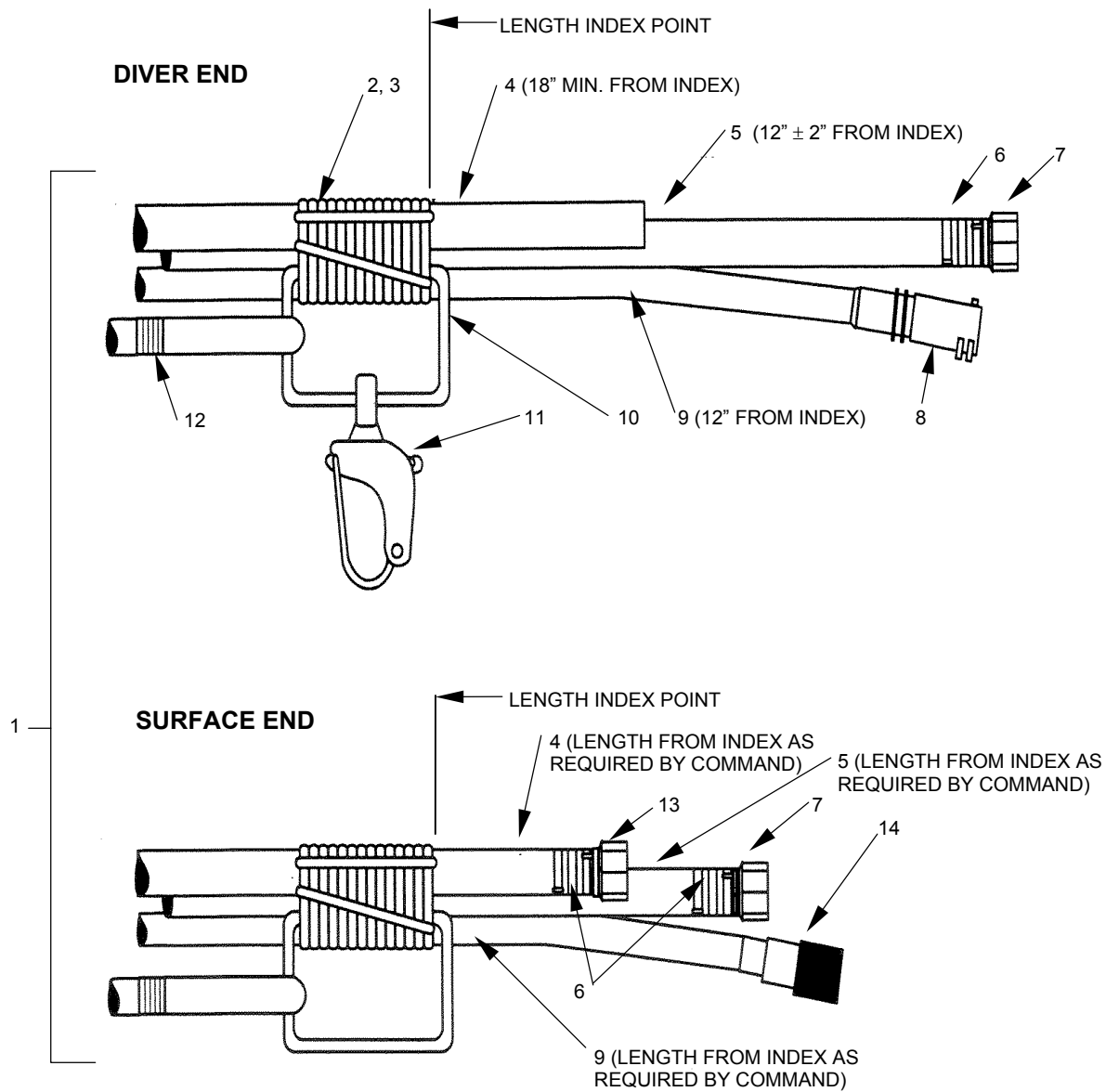

Figure 6-1. Mk 20 3-Part Standard Umbilical Assembly w/Separate Strength Member (Amron)

Table 6-1. Parts List, Mk 20 3-Part Standard Umbilical Assembly with Separate Strength Member (Amron)

Fig./Index Number	CAGE Code	Part Number	Description	Qty	Notes
6-1-1	6S753	33HB1-MK20-TN-0-300	Amron standard Gates 4-part umbilical assembly, 300' (breathing air and pneumofathometer hoses and communication cable, plus strength member). Specify length and fittings required.	1	
-2	1G359	266050	Seizing, nylon cord, 3/16", or equivalent	AR	
-3	14819	827-2	Tape, diver umbilical, 2 in. x 36 yds, or equivalent	AR	
-4	3AY00	HDA0104	Diveline, 1/4" Aquaflow pneumofathometer hose, 250-psi, thermoplastic	1	1,7
	85757	3630-04	Synflex 1/4" pneumofathometer hose		
-5	3AY00	HDA0106	Diveline Aquaflow 3/8", 500-psi thermoplastic hose	1	2,4 3,7
	24161	33HB-3/8 ID	Hose, 3/8" ID, 1125-psi working pressure (Gates)		
-6	70847	JS401	Clamp, preformed, 13/16", smooth ID	AR	
	6S753	J240	Band-it clamp, used with Synflex hose		
-7	6S753	60202	Fitting, swaged, oxygen, w/ 9/16-18 O ₂ nut, used on HDA0106 hose	2	
-8	90129	WP-4-FS	Marsh Marine, female 4-pin waterproof connector	1	
		RMG4FS	Marsh Marine (Secan Brantner) female 4-pin waterproof connector		
-9	3AY00	CDR010411	Diveline combined strength/communication cable	1	5,7
	0Y0B0	CAF0334	JDR combined strength/communication cable		
	6S753	CC1	Communication cable, 2 pr, 20AWG, shielded		
-10	6S753	HB174	D-ring, 3/8" diameter, stainless steel, or equivalent	1	
-11	6S753	45-10D	Shackle, snap, w/ welded D-ring	1	6, 8 6
	6S753	45-10	Shackle, snap (shackle only)		
-12	6S753	3/8" NY-BRAID	Double braid 3/8" synthetic line, or equivalent	AR	
-13	6S753	AHB-40202	Swage fitting, 1/4" ID hose, with 9/16-18 O ₂ nut	1	
-14	6S753	14001R/B	Connector, surface end, banana plugs	AR	9
	6S753	MS-3116F-10-6P	Hydro-Comm connector, 6-pin		
	6S753	MS-3116F-14-5P	Hydro-Comm connector, 5-pin		
Not Shown	6S153	UMB-SH-50-GRN	50' umbilical sheath, green	AR	
		UMB-SH-50-RED	50' umbilical sheath, red		
		UMB-SH-50-YEL	50' umbilical sheath, yellow		

Notes:

- Length from diver end seizing to end of pneumofathometer hose is 18".
- Requires use of Diveline DVL-FXFSP20606 fitting.
- Requires use of Amron fitting ABH60202 and buckle-style clamps, 3/8" ID.
- Length from diver end seizing to end of gas breathing hose is 12" ± 2".
- Length from diver end seizing to end of communication cable is 12".
- Required on diver end; optional on surface end of umbilical assembly.
- Length from surface end seizing to end of pneumofathometer hose, breathing gas hose, and communication cable is as required by the ordering command.
- Use of this snap shackle and D-ring eliminates part -10 of this assembly.
- Surface communication connectors as required by end user.

SS521-AH-PRO-010

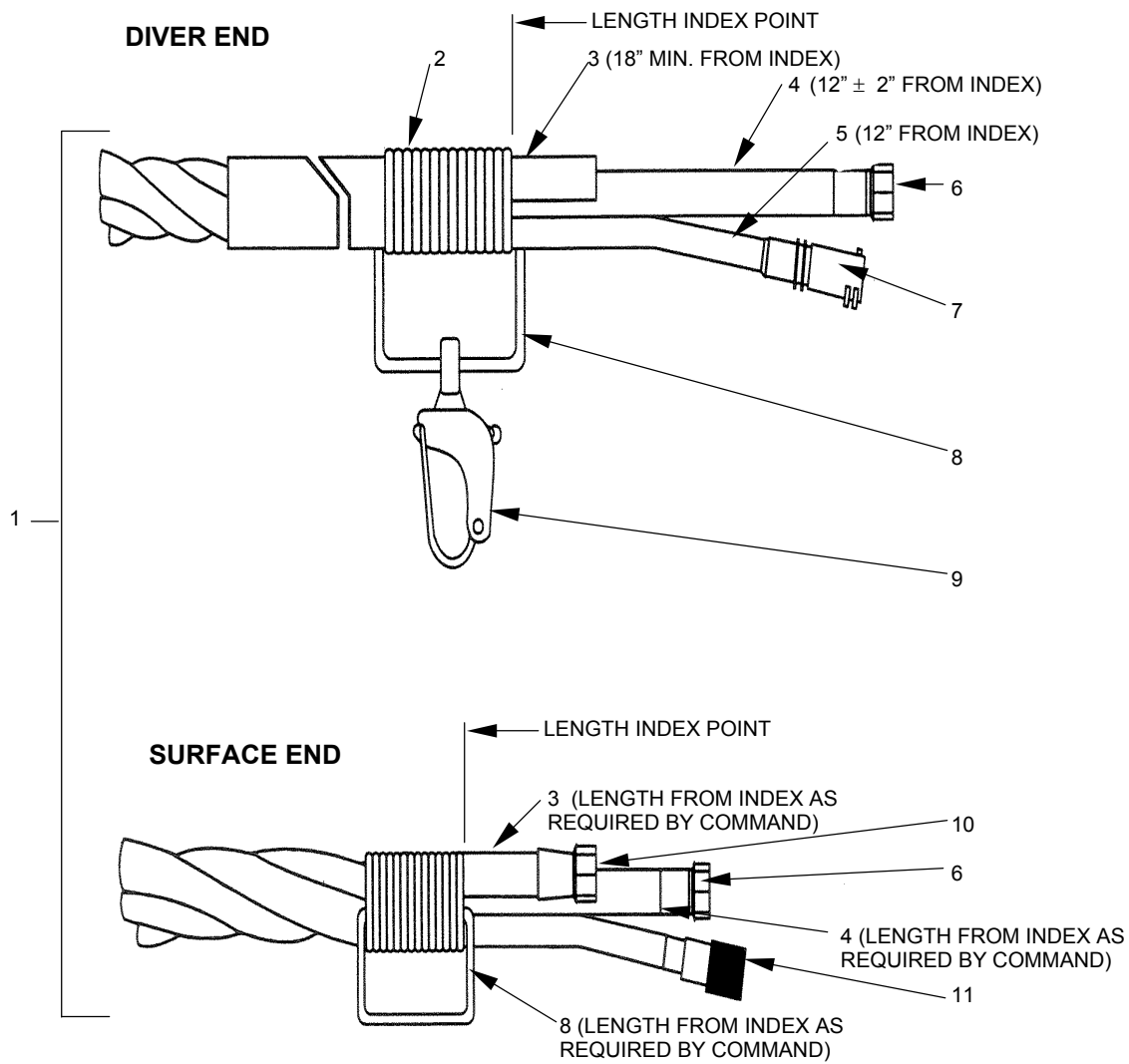

Figure 6-2. Mk 20 Aqualite Spiral-Wound Umbilical Assembly (Mar-Vel)

Table 6-2. Parts List, Mk 20 Aqualite Spiral-Wound Umbilical Assembly (Mar-Vel)

Fig./Index Number	CAGE Code	Part Number/ NSN	Description	Qty	Notes
6-2-1	14819	ADU-0001-1	Mk 20 Aqualite 3-part spiral-wound umbilical. Nominal length is 600'; actual length 625'. Specify end fittings.	1	1
		ADU001-639	Mk 20 Aqualite 3-part spiral-wound umbilical. Nominal length is 600'; actual length 625'. Specify end fittings.		
-2	1G359	266050	Seizing, nylon cord, 3/16", or equivalent	AR	
-3	85757	3630-04	Pneumofathometer hose, Airline Hydraulics Corp, 1/4", 500-psi working pressure	1	2
-4	0Y0B0	HAL0106	3/8" Aqualite hose, 500-psi working pressure	1	3
-5	0Y0B0	CPU 04A11	Communication cable, JDR Cable Systems	1	4
-6	0Y0B0	XF06SR1F06	Fitting, female 9/16-18 O ₂ nut, to female 3/8" Aqualite hose	2	
-7	90129	COMS3116F10-6P	Connector, male, Hydro-Comm (Mk 20 mask)	1	
-8	14819	DR11	D-ring, 1/4" diameter, stainless steel	2	
	6S753	HB174 or equivalent	D-ring, 3/8" diameter, stainless steel		
-9	6D887	110000S 4030-01-324-4866	Shackle, snap	1	5
	14819	11000FR	Shackle, snap		
	81348	4030-01-321-6008			
	14819	45-10D	Shackle, snap, w/ welded D-ring		6
-10	0Y0B0	XF06SP3F04	Fitting, 9/16-18 oxygen to female 1/4" Aqualite hose	1	
-11	14819	CO10850	Connector, surface end, banana plugs	2	
	14819	COMS3116F10-6P	Connector surface end, 6-pin, male	1	
Not shown	14819	AQPC-50-RED	Umbilical cover, 50', red	AR	
	14819	AQPC-50-GRN	Umbilical cover, 50', green	AR	
	14819	AQPC-50-YLW	Umbilical cover, 50', yellow	AR	

Notes:

- When ordering, specify length in feet.
- When ordering, specify length in feet. Pneumofathometer hose required to extend at least 18" beyond seizing on diver end; required length on surface end to be determined by ordering command.
- When ordering, specify length in feet. Breathing air hose required to extend 12" ± 2" beyond seizing on diver end; required length on surface end to be determined by ordering command.
- Communication cable may be ordered with telephone connector. Communication cable required to extend 12" ± 2" beyond seizing on diver end; required length on surface end to be determined by ordering command.
- Required on diver end; optional on surface end of assembly.
- Use of this snap shackle and D-ring assembly eliminates part –8 of this assembly.

SS521-AH-PRO-010

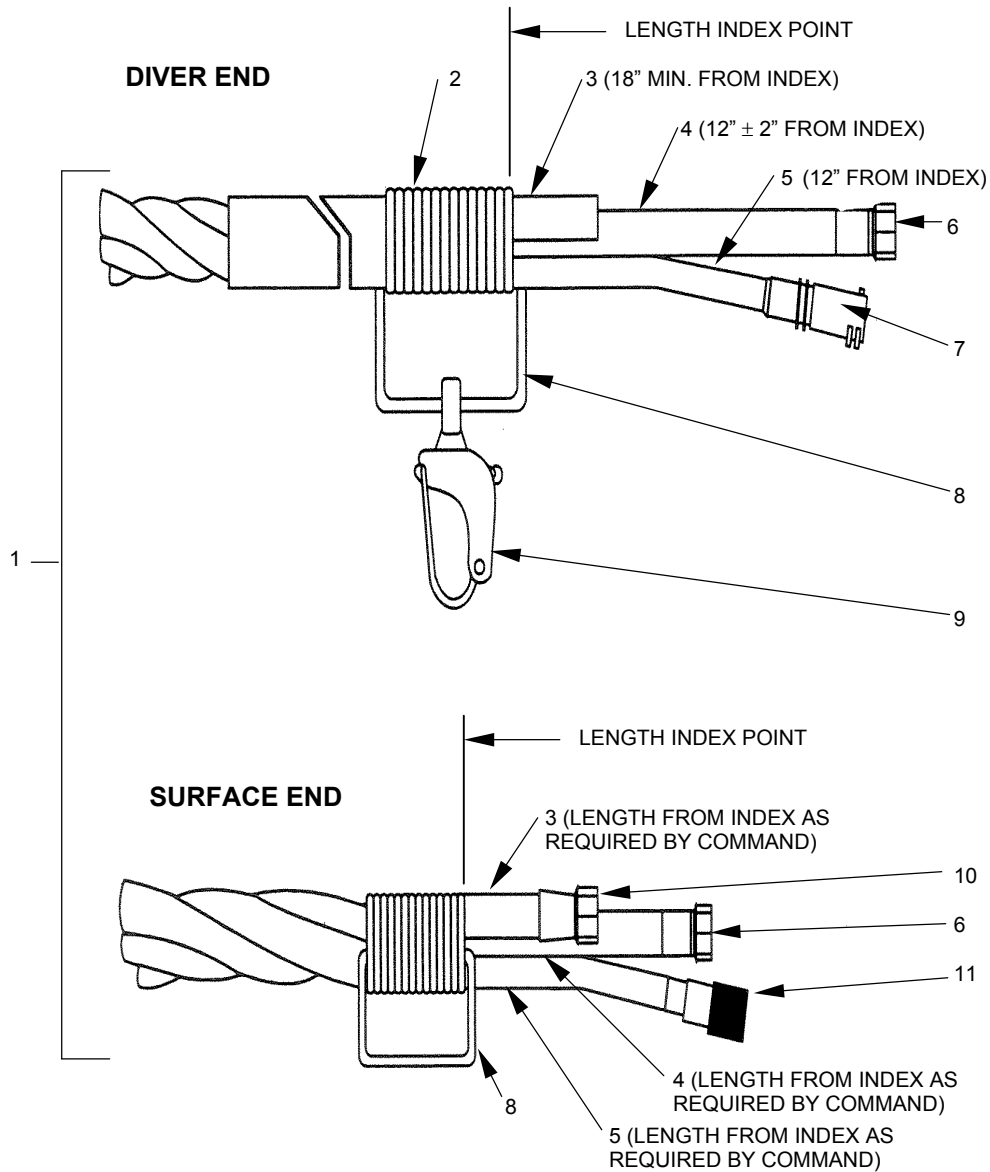

Figure 6-3. Mk 20 3-Part Spiral-Wound Umbilical Assembly (Amron)

Table 6-3. Parts List, Mk 20 3-Part Spiral-Wound Umbilical Assembly (Amron)

Fig./Index Number	CAGE Code	Part Number/ NSN	Description	Qty	Notes
6-3-1	6S753	UMB-ADU-1MK20-MM-(Length)	Amron 3-part spiral-wound umbilical, Mk 20, with Marsh Marine communication connector; specify length.	1	
		UMB-ADU-1MK20-MM-TJ-(Length)	Amron 3-part spiral-wound umbilical, Mk 20, with telephone jack communication connector; specify length.		
-2	1G359	266050	Seizing, nylon cord, 3/16", or equivalent	AR	
-3	3AY00	HDA0104	Aquaflow 1/4" pneumofathometer hose, 1/4" ID, 250-psi working pressure	1	1,2,6
	85757	3630-04	Synflex 1/4" pneumofathometer hose		
-4	3AY00	HAL-0106	Aquaflow 3/8" ID hose, 500-psi working pressure	1	3,6
-5	3AY00	DVL-CDR010411	Reinforced communication cable/lifeline	1	4,6
-6	6S753	ABH-60202	Brass oxygen fitting, swage for 3/8" hose (9/16-18 O ₂ nut) used on HDA0106 hose (Diveline p/n DVLFXSP20606)	2	2,3
-7	6S753	RMGF4	4-pin, Marsh Marine connector	1	4
		DC5CF-1	Nexus, female connector		
		MS-3116F-10-6P	Hydro-Comm connector, 6-pin		
		MS-3116F-14-5P	Hydro-Comm connector, 5-pin		
-8	6S753	HB174	D-ring	1	
-9	6S753	45-10D	Shackle, snap, w/ welded D-ring	1	5, 7
-10	6S753	AHB 60202	LP brass oxygen fitting, for 1/4" (9/16"-18 O ₂ nut), 1/4" ID hose (Diveline p/n FXFSP10604)	1	6
-11	6S753	14001R	Connector, surface end, banana plug (black)	1	8
		14001B	Connector, surface end, banana plug (red)	1	
Not Shown	6S753	UMB-SH-50-GRN	50' umbilical sheath, green	AR	
		UMB-SH-50-RED	50' umbilical sheath, red		
		UMB-SH-50-YEL	50' umbilical sheath, yellow		

Notes:

- 1 Length from diver end seizing to end of pneumofathometer hose is 18".
- 2 HDA hose requires use of Diveline fittings.
- 3 Length from diver end seizing to end of gas breathing hose is 12" ± 2".
- 4 Length from diver end seizing to end of communication cable is 12".
- 5 Required on diver end; optional on surface end of umbilical assembly.
- 6 Length from surface end seizing to end of pneumofathometer hose, breathing gas hose, and communication cable is as required by the ordering command.
- 7 Use of this snap shackle and D-ring assembly eliminates part -8 of this assembly.
- 8 As required by end user communication system.

SS521-AH-PRO-010

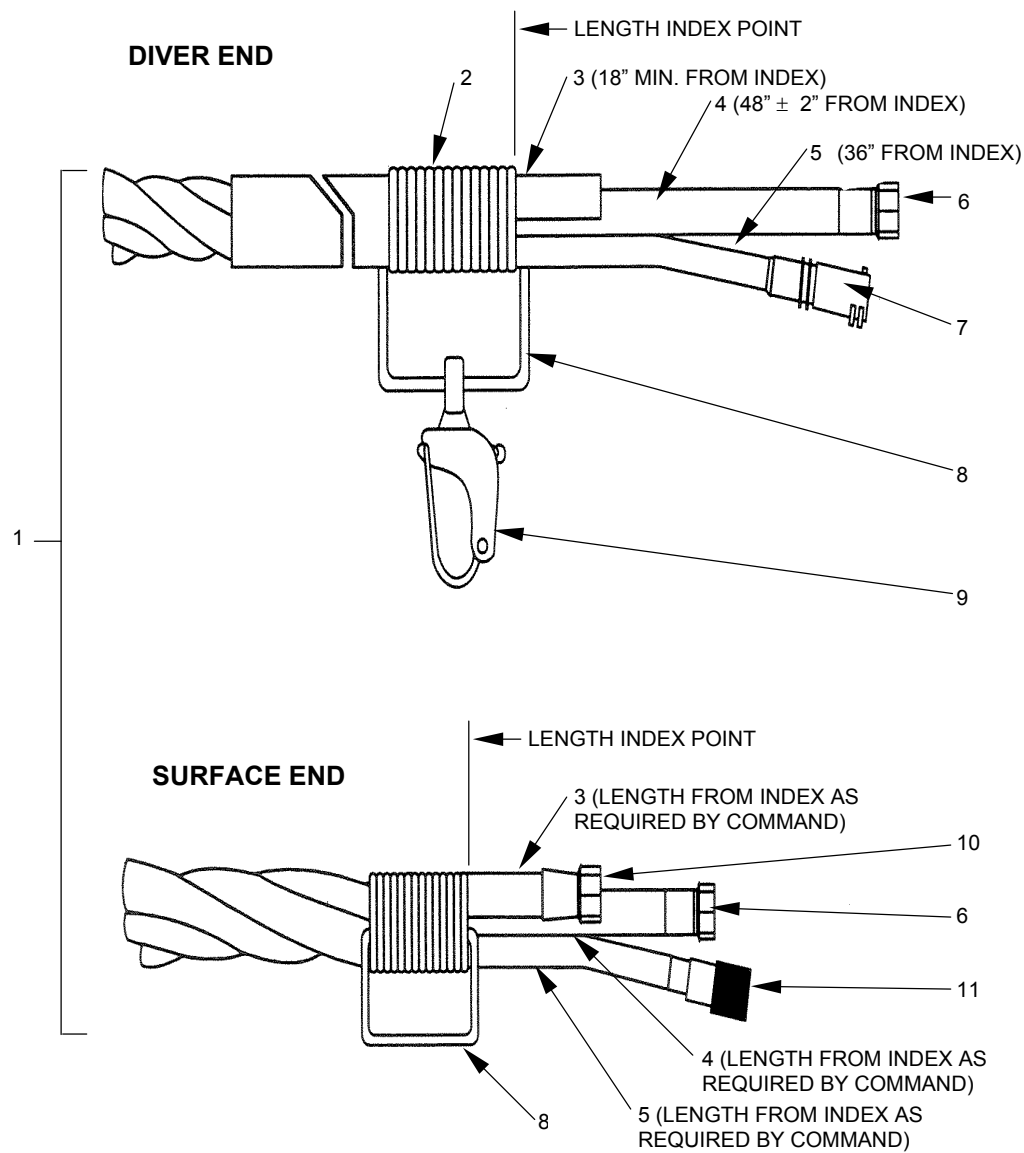

Figure 6-4. Mk 21 Aqualite 3-Part Spiral-Wound Umbilical Assembly (Mar-Vel)

Table 6-4. Parts List, Mk 21 3-Part Aqualite Spiral-Wound Umbilical Assembly (Mar-Vel)

Fig./ IndexNo.	CAGE Code	Part Number/ NSN	Description	Qty	Notes
6-4-1	14819	ADU001-1	Mk 21 Aqualite 3-part spiral-wound umbilical assembly. Nominal length 300'; actual length 330'. Specify end fittings and lengths.	1	1
		ADU-001-639	Mk 21 Aqualite 3-part spiral-wound umbilical assembly. Nominal length 600'; actual length 625'. Specify end fittings and lengths.		
-2	1G359	266050	Seizing, nylon cord, 3/16", or equivalent	AR	
-3	85757	3630-04	1/4" pneumofathometer hose, Synflex	1	2
-4	0Y0B0	HAL0106	3/8" Aqualite hose, JDR Cable Systems	1	3
-5	0Y0B0	CPU 04A11	Communication cable, JDR Cable Systems	1	4
-6	0Y0B0	XF06SP1F06	Fitting, swage, 3/8" hose to 9/16-18 oxygen nut	2	8
	6S753	ABH-60202	Fitting, 3/8" hose barb to 9/16-18 oxygen nut. Used in conjunction with buckle-style clamps.		
-7	90129	WP-4-FS	Connector, Marsh Marine, female Mk 21 helmet	1	4
-8	14819	DR11	D-ring, 1/4" diameter, stainless steel	2	
-9	6D887	110000S	Shackle, snap	1	5
	81348	4030-01-324-4866			
	14819	1000FR	Shackle, snap		
	81348	4030-01-321-60081			
	6S753	45-10D	Shackle, snap, w/ welded D-ring		5, 6
-10	0Y0B0	XF06SP3F04	Fitting, swage, 1/4" hose to 9/16-18 oxygen nut	1	
-11	14819	CO10850	Connector, surface end, banana plugs	2	7
	14819	COMS3116F10-6P	Connector surface end, 6-pin, male	1	
Not shown	14819	AQPC-50-RED	Umbilical cover, 50', red	AR	
	14819	AQPC-50-GRN	Umbilical cover, 50', green	AR	
	14819	AQPC-50-YLW	Umbilical cover, 50', rellow	AR	

Notes:

- When ordering, specify length in feet.
- When ordering, specify length in feet. Pneumofathometer hose required to extend at least 18" beyond seizing on diver end; required length on surface end to be determined by ordering command.
- When ordering, specify length in feet. Breathing air hose required to extend 48" \pm 2" beyond seizing on diver end; required length on surface end to be determined by ordering command.
- Communication cable required to extend 36" beyond seizing on diver end; required length on surface end to be determined by ordering command.
- Required on diver end; optional on surface end of assembly.
- Use of this snap shackle and D-ring eliminates part -8 of this assembly.
- As required by user's communication system.
- Required when Aqualite hose is used.

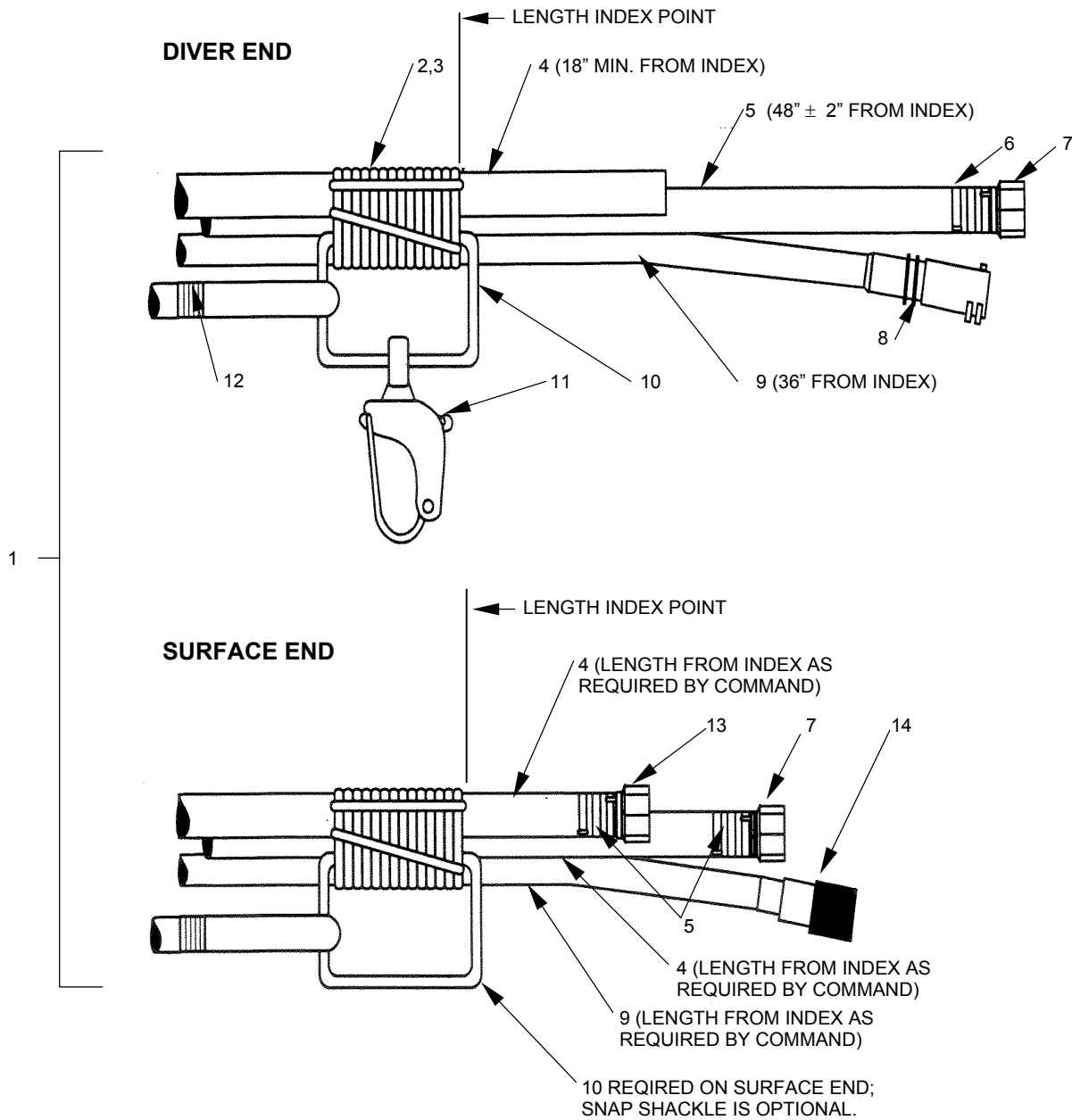

Figure 6-5. Mk 21 3-Part Standard Umbilical Assembly with Separate Strength Member (Amron)

Table 6-5. Parts List, Mk 21 3-Part Standard Umbilical Assembly with Separate Strength Member (Amron)

Fig./Index Number	CAGE Code	Part Number	Description	Qty	Notes
6-5-1	6S753	33HB1-MK21-MN-0-300	Amron standard Gates 4-part umbilical assembly, 300' (breathing air and pneumofathometer hoses and communication cable plus strength member). Specify length and fittings required.	1	
		33HB1-MK21-MN-0-600	Amron standard Gates 4-part umbilical assembly, 600' (breathing air and pneumofathometer hoses and communication cable plus strength member). Specify length and fittings required.		
-2	1G359	266050	Seizing, nylon cord, 3/16", or equivalent	AR	
-3	14819	827-2	Tape, diver umbilical, 2 in. x 36 yds, or equivalent	AR	
-4	6S753	HDA0104	Diveline, 1/4" Aquaflow pneumofathometer hose, 250-psi, thermoplastic	1	1,7
	6S753	3630-04	Synflex, 1/4", 500-psi pneumofathometer hose		
-5	6S753	HDA0106	Diveline Aquaflow 3/8", 500-psi thermoplastic hose	1	2,4
	24161	33HB-3/8 ID	Hose, 3/8" ID, 1125-psi working pressure (Gates)		3,7
-6	6S753	J240	Clamp, preformed, 13/16", smooth ID	AR	10
-7	6S753	ABH-60202	Fitting, swage 3/8" hose to oxygen, w/ 9/16-18 O ₂ nut (Diveline p/n DVLFSFXP20606)	2	10
-8	0YFD5	DC5CF-1	Telephone connector, 5-wire	1	
	6S753	RMG4FS	Marsh Marine, female 4-pin waterproof connector		
	90129	WP-4-FS	Marsh Marine (Secan Brantner) female 4-pin waterproof connector		
-9	3AY00	DVL-CDR010411	Diveline combined strength/communication cable	1	5,7
	0Y0B0	CAF0334	JDR combined strength/communication cable		
	6S753	CC1	Communication cable, 2 pr, 20AWG, shielded		
-10	6S753	HB174	D-ring, 3/8" diameter, stainless steel, or equivalent	1	
-11	6S753	45-10D	Shackle, snap, w/ welded D-ring	1	8
	6S753	45-10	Shackle, snap (shackle only)		6
-12	6S753	3/8" NY-BRAID	Double braid 3/8" synthetic line, or equivalent	AR	
-13	6S753	AHB40202	Fitting, swage 1/4" ID hose to 9/16-18 O ₂ nut (Diveline p/n DVLFXFSB10604)	1	10
-14	6S753	14001R/B	Connector, surface end, banana plugs	AR	9
	6S753	MS-3116F-10-6P	Hydro-Comm connector, 6-pin		
	6S753	MS-3116F-14-5P	Hydro-Comm connector, 5-pin		
Not shown	6S153	UMB-SH-50-GRN	50' umbilical sheath, green	AR	
		UMB-SH-50-RED	50' umbilical sheath, red		
		UMB-SH-50-YEL	50' umbilical sheath, yellow		

Notes:

- 1 Length from diver end seizing to end of pneumofathometer hose is 18".
- 2 Requires use of Diveline DVL-FXFSP20606 fitting.
- 3 Requires use of Amron fitting ABH60202 and buckle-style clamps 3/8" ID.
- 4 Length from diver end seizing to end of gas breathing hose is 48" ± 2".
- 5 Length from diver end seizing to end of communication cable is 36".
- 6 Required on diver end; optional on surface end of umbilical assembly.
- 7 Length from surface end seizing to end of pneumofathometer hose, breathing gas hose, and communication cable is as required by the ordering command.
- 8 Use of this snap shackle and D-ring eliminates part -10 of this assembly.
- 9 As required by user's communication system.
- 10 Required when Synflex or Aqualite hose is used.

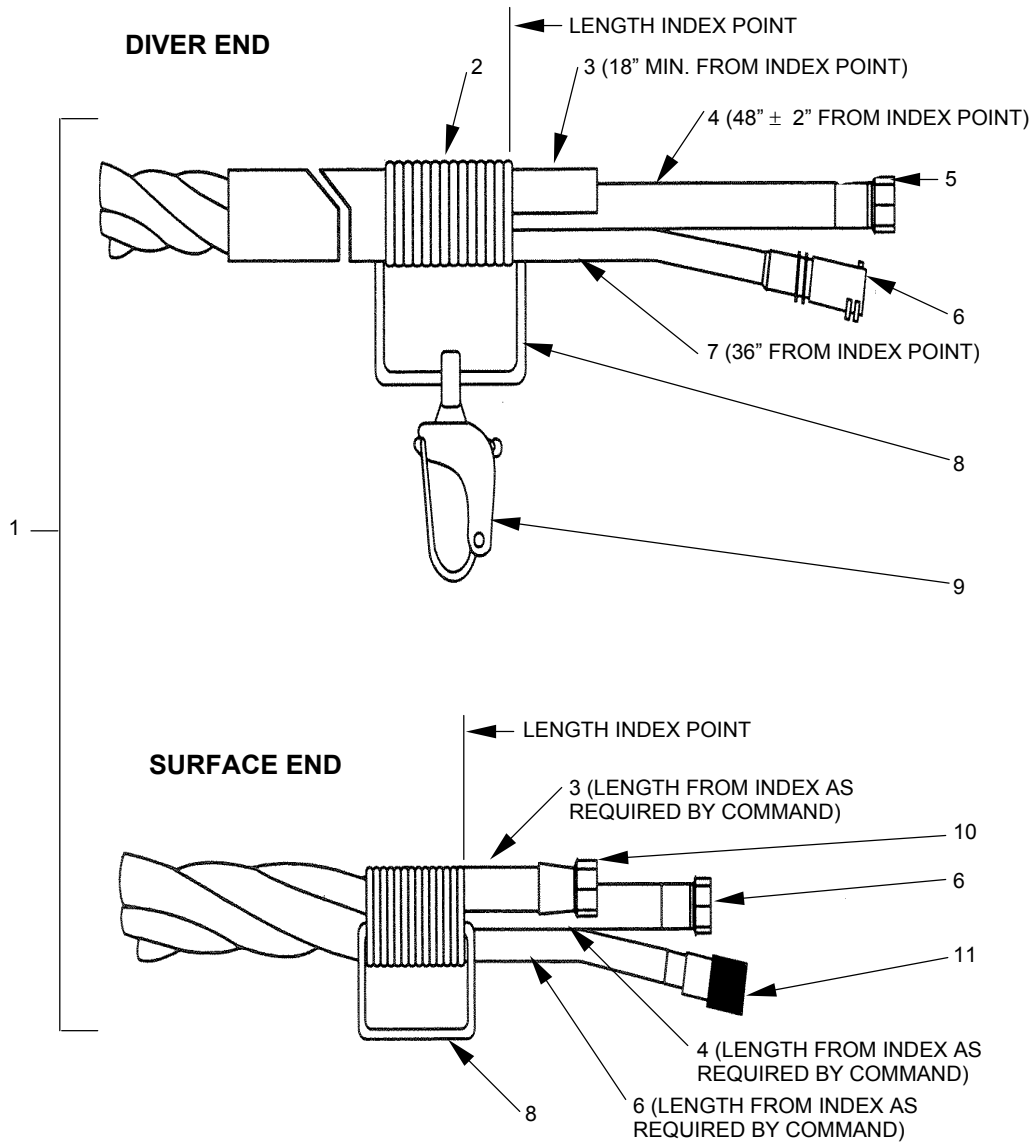

Figure 6-6. Mk 21 3-Part Spiral-Wound Umbilical Assembly with Reinforced Communication Cable/Lifeline (Amron)

Table 6-6. Parts List, Mk 21 3-Part Spiral-Wound Umbilical Assembly with Reinforced Communication Cable/Lifeline (Amron)

Fig./Index Number	CAGE Code	Part Number	Description	Qty	Notes
6-6-1	6S753	UMB-ADU-1MK21-MM-(Length)	Amron 3-part spiral-wound umbilical, Mk 21; specify length and communication fittings required.	1	
-2	1G359	266050	Seizing, nylon cord, 3/16", or equivalent	AR	
-3	3AY00	HDA0104	Aquaflow 1/4" pneumofathometer hose, 1/4" ID, 250-psi working pressure	1	1,2,6
-4	3AY00	HDA0106	Aquaflow 3/8" ID hose, 500-psi working pressure	1	3,6
-5	3AY00	FXFSP20606	Fitting, swage, 3/8" hose to 9/16-18 O ₂ nut (Amron p/n DVLFXFSP20606)	2	2,3
-6	6S753	RMG4FS	Marsh Marine connector, 4-pin	1	4
	90129	WP-4-FS	Marsh Marine (Secan Brantner) female 4-pin waterproof connector		
	6S753	DC5CF-1	Nexus, female connector		
-7	3AY00	DVL-CDR010411	Reinforced communication cable/lifeline	1	4,6
-8	6S753	HB174	D-ring, 3/8" stainless steel	1	
-9	6S753	45-10D	Shackle, snap, w/ welded D-ring	1	5, 7
-10	3AY00	FXFSB10604	Fitting, swage, 1/4" hose to 9/16-18 O ₂ nut (Amron p/n AHB40202)	1	6
-11	6S753	14001B	Connector, surface end, banana plug (black)	1	8
		14001R	Connector, surface end, banana plug (red)		
	6S753	MS-3116F-10-6P	Hydro-Comm connector, 6-pin		
	6S753	MS-3116F-14-5P	Hydro-Comm connector, 5-pin		
Not shown	6S753	UMB-SH-50-GRN	50' umbilical sheath, green	AR	
		UMB-SH-50-RED	50' umbilical sheath, red		
		UMB-SH-50-YEL	50' umbilical sheath, yellow		

Notes:

- 1 Length from diver end seizing to end of pneumofathometer hose is 18" ± 2".
- 2 HDA hose requires use of Diveline fittings.
- 3 Length from diver end seizing to end of gas breathing hose is 48" ± 2".
- 4 Length from diver end seizing to end of communication cable is 36".
- 5 Required on diver end; optional on surface end of umbilical assembly.
- 6 Length from surface end seizing to end of pneumofathometer hose, breathing gas hose, and communication cable is as required by the ordering command.
- 7 Use of this snap shackle and D-ring eliminates part -10 of this assembly.
- 8 As required by user's communication system.

SS521-AH-PRO-010

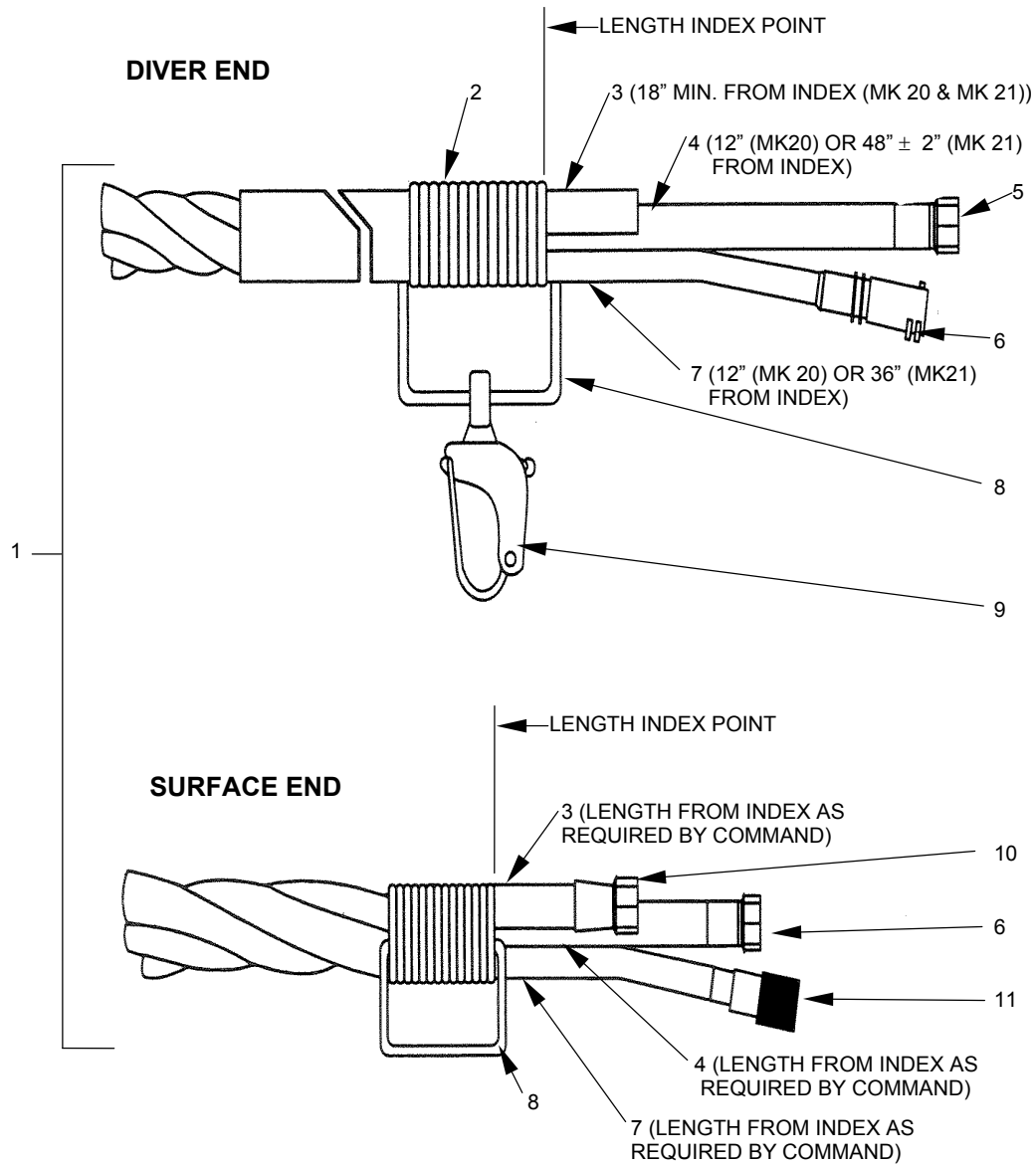

Figure 6-7. Mk 20/21 3-Part Spiral-Wound Umbilical Assembly with Reinforced Communication Cable/Lifeline (Diveline)

Table 6-7. Parts List, Mk 20/21 3-Part Spiral-Wound Umbilical Assembly with Reinforced Communication Cable/Lifeline (Diveline)

Fig./Index Number	CAGE Code	Part Number/ NSN	Description	Qty	Notes
6-7-1	3AY00	UDA0103	Aquaflow 3-member cable umbilical with reinforced communication cable/lifeline. Specify end fittings (Mk 20 or Mk 21) and lengths.	1	
-2	1G359	266050	Seizing, nylon cord, 3/16", or equivalent	AR	
-3	3AY00	HDA0104	Aquaflow 1/4" pneumofathometer hose, 1/4" ID, 250-psi working pressure	1	1, 5
-4	3AY00	HDA0106	Aquaflow 3/8" ID hose, 500-psi working pressure	1	2, 5
-5	3AY00	XFSP20606	Fitting, swage, 3/8" ID hose to 9/16-18 O ₂ nut	2	
-6	3AY00	RMGF4	Marsh Marine Connector, 4-pin	1	
-7	3AY00	CDR010411	Reinforced communication cable/lifeline	1	3, 5
-8	3AY00	SSDR01	D-ring (surface end)	1	
-9	3AY00	FA45-10/D	Shackle, snap, w/ welded D-ring (diver end)	1	4, 5, 6
	6S753	45-10	Shackle, snap (shackle only)		4
-10	3AY00	FXFSB10604	Fitting, swage, 1/4" ID hose to 9/16-18 O ₂ nut	1	
-11	3AY00	MPD02B	Connector, surface end, banana plug (black)	1	7
		MPDOCR	Connector, surface end, banana plug (red)		
	6S753	MS-3116F-10-6P	Hydro-Comm connector, 6-pin		
		MS-3116F-14-5P	Hydro-Comm connector, 5-pin		
Not Shown	6S153	UMB-SH-50-GRN	50' umbilical sheath, green	AR	
		UMB-SH-50-RED	50' umbilical sheath, red		
		UMB-SH-50-YEL	50' umbilical sheath, yellow		

Notes:

- 1 Length from diver end seizing to end of pneumofathometer hose is 18" minimum (Mk 20 and Mk 21).
- 2 Length from diver end seizing to end of gas breathing hose is 12" ± 2" (Mk 20) or 48" ± 2" (Mk 21).
- 3 Length from diver end seizing to end of communication cable is 12" (Mk 20) or 36" (Mk 21).
- 4 Required on diver end; optional on surface end of umbilical assembly.
- 5 Length from surface end seizing to end of pneumofathometer hose, breathing gas hose, and communication cable is as required by the ordering command.
- 6 Use of this snap shackle and D-ring eliminates part -9 of this assembly
- 7 As required by user's communication system.

SS521-AH-PRO-010

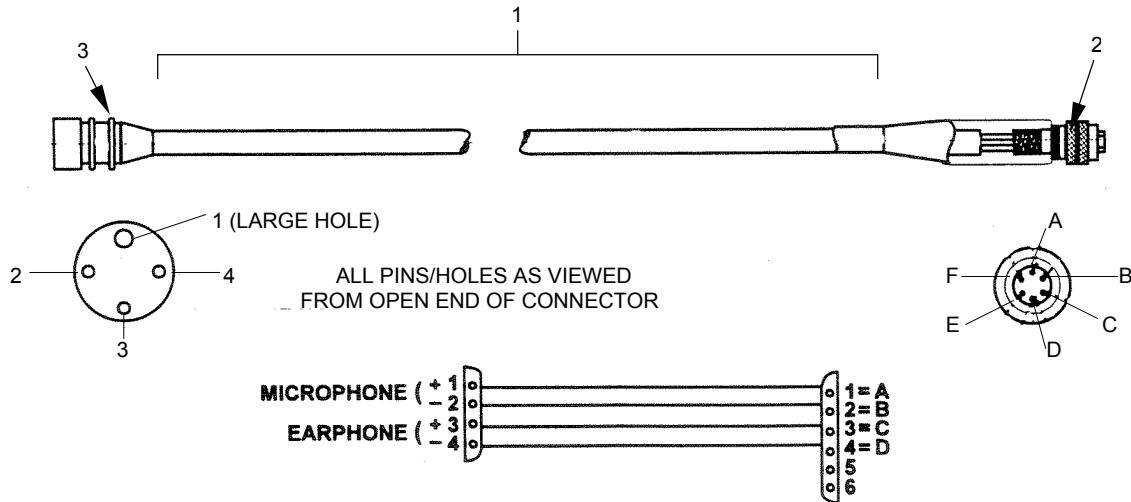

Figure 6-8. Umbilical Communication Cable Wiring

Table 6-8. Parts List, Communication Cable

Fig./Index Number	CAGE Code	Part Number/ NSN	Description	Qty	Notes
6-8-1	0GM59 14819	CAF0334- (Length in feet)	Cable, combination strength/ communication, shielded pairs, length and connector ends as specified by ordering activity.	1	1
	20857	SB-38784	Cable, shielded pairs – two units, water blocked, length and connector ends as specified by ordering activity.		
	3AY00	CDR010411	Cable, shielded pairs, length and connector ends as specified by ordering activity (Diveline).		
	0Y0B0	CPU04A11	Cable, communication, shielded pairs, length and connector ends as specified by ordering activity (JDR).		
	6S753	CC1	Cable, shielded pairs, length and connector ends as specified by ordering activity (Amron).		
-2	14819	14001B	Dual banana plugs, black	1	1
	14819	WPS-4-MP	Marsh Marine connector, male, 4-pin		
		58MLS-1	Locking sleeve for WPS-4-MP (optional)		
	6S753	MS-3116F-10- 6P	Hydro-Comm connector, 6-pin		
6S753	MS-3116F-14- 5P	Hydro-Comm connector, 5-pin			
-3	14819	WP-4-FS	Female 4-pin Marsh Marine connector	1	1
		58FLS-2	Locking sleeve for WP-4-FS (optional)		
			Mk 20 Nexus telephone jack		

Notes:

- 1 When wiring communication cable using shielded cable pairs, the microphone shall be wired to one shielded pair and the earphones to the other shielded pair.

APPENDIX A

Umbilical Ordering Worksheet

SS521-AH-PRO-010

THIS PAGE INTENTIONALLY LEFT BLANK.

Umbilical Ordering Worksheet

SS521-AH-PRO-010

Brief description of assembly:		Type of mask/helmet		
		Circle one: Mk 20 Mk 21		
Component		Umbilical construction		
		Circle one: Spiral Parallel		
Test Requirements	Notes	CAGE Code	Part Number/ Dimension	
Breathing air hose _____' overall length	Hydrostatic test to 750 psi or twice working pressure (whichever is less). Lower pressure and load/pressure test to 500-psi/200-lb dead weight.	Requires 9/16-18 oxygen fitting each end. May be swage or barb-style fitting.		
Pneumofathometer hose: _____' overall length	Hydrostatic test to 200 psi.	Requires 9/16-18 oxygen fitting on surface end. May be swage or barb-style fitting.		
Strength member required YES NO		Not required on spiral construction. May be either separate strength member or combined communication/strength member.		
Communication cable _____' overall length	Check continuity: end-to-end, approx. 1 ohm/100' Check resistance: wire-to-wire/ground – greater than 1 megohm	May be combined strength/communication cable as required. See section 6.		
Comm cable diver end fitting		Refer to Mk 20 and Mk 21 technical manual.		
Comm cable: surface end fitting		As required by end user communication system.		
Snap shackle		Required at diver end; optional at surface end.		
D-ring	Load test to 500-lb dead weight if cut and welded to install shackle.	Required at surface end and diver end of assembly.		
Required length from diver end seizing: Diver air hose Pneumo hose Comm cable		See figures in section 6 for required lengths.		_____ _____ _____
Required length from surface end seizing: Diver air hose Pneumo hose Comm cable	As required by end user.			_____ _____ _____
Seizing YES	Seizing as required by section 3-1.4 of manual.			
Test tags installed YES	Test tags to show test date, test pressure, tester, and location of test.	Required on diver air hose, pneumofathometer hose, and hot water hose (if installed).		
Builder certificate required YES	Show manufacturer name, manufacture date, test date, test pressures, and test location.	Required on all Navy hoses.		
Other accessory components	As requested by end user.	Add camera, hot water hoses as indicated by section 3-2.4 of manual.		

Ref: NAVSEAINST 4160.3A NAVSEA S0005-AA-GYD-030/TMMP			
NAVSEA/SPAWAR TECHNICAL MANUAL DEFICIENCY/EVALUATION REPORT (TMDER)			
INSTRUCTIONS: Continue on 8 1/2" x 11" page if additional space is needed.			
1. Use this report to indicate deficiencies, problems and recommendations relating to publications.			
2. For CLASSIFIED TMDERs see OPNAVINST 5510H for mailing requirements.			
3. For TMDERs that affect more than one publication, submit a separate TMDER for each.			
4. Submit TMDERs at web site http://nsdsa.phdnswc.navy.mil or mail to: COMMANDER, CODE 310 TMDER BLDG 1388, NAVSURFWARCENDIV NSDSA, 4363 MISSILE WAY, PORT HUENEME CA 93043-4307			
1. PUBLICATION NUMBER SS521-AH-PRO-010	2. VOL/PART	3. REV/DATE OR CHG/DATE REVISION 1	4. SYSTEM/EQUIPMENT ID
5. TITLE OF PUBLICATION U.S. Navy Diving Umbilical (UBA Mk 20 and Mk 21) Description, Materials and Assembly		6. REPORT CONTROL NUMBER (6 digit UIC-YY-any four: xxxxxx-03-xxxx)	
7. RECOMMEND CHANGES TO PUBLICATION			
7a. Page #	7b. Para #	7c. RECOMMENDED CHANGES AND REASONS	
8. ORIGINATOR'S NAME AND WORK CENTER		9. DATE	10. ORIGINATOR'S E-MAIL ADDRESS
11. TMMA of Manual (NSDSA will complete)			
12. SHIP OR ACTIVITY Name and Address (Include UIC/CAGE/HULL)		13. Phone Numbers:	
		Commercial () ____ - ____	
		DSN ____ - ____	
		FAX () ____ - ____	

Ref: NAVSEAINST 4160.3A NAVSEA S0005-AA-GYD-030/TMMP			
NAVSEA/SPAWAR TECHNICAL MANUAL DEFICIENCY/EVALUATION REPORT (TMDER)			
INSTRUCTIONS: Continue on 8 1/2" x 11" page if additional space is needed.			
4. Use this report to indicate deficiencies, problems and recommendations relating to publications.			
5. For CLASSIFIED TMDERs see OPNAVINST 5510H for mailing requirements.			
6. For TMDERs that affect more than one publication, submit a separate TMDER for each.			
4. Submit TMDERs at web site http://nsdsa.phdnswc.navy.mil or mail to: COMMANDER, CODE 310 TMDER BLDG 1388, NAVSURFWARCENDIV NSDSA, 4363 MISSILE WAY, PORT HUENEME CA 93043-4307			
1. PUBLICATION NUMBER SS521-AH-PRO-010	2. VOL/PART	3. REV/DATE OR CHG/DATE REVISION 1	4. SYSTEM/EQUIPMENT ID
5. TITLE OF PUBLICATION U.S. Navy Diving Umbilical (UBA Mk 20 and Mk 21) Description, Materials and Assembly		6. REPORT CONTROL NUMBER (6 digit UIC-YY-any four: xxxxxx-03-xxxx)	
7. RECOMMEND CHANGES TO PUBLICATION			
7a. Page #	7b. Para #	7c. RECOMMENDED CHANGES AND REASONS	
8. ORIGINATOR'S NAME AND WORK CENTER		9. DATE	10. ORIGINATOR'S E-MAIL ADDRESS
11. TMMA of Manual (NSDSA will complete)			
12. SHIP OR ACTIVITY Name and Address (Include UIC/CAGE/HULL)		13. Phone Numbers:	
		Commercial () ____ - ____	
		DSN ____ - ____	
		FAX () ____ - ____	

Ref: NAVSEAINST 4160.3A NAVSEA S0005-AA-GYD-030/TMMP			
NAVSEA/SPAWAR TECHNICAL MANUAL DEFICIENCY/EVALUATION REPORT (TMDER)			
INSTRUCTIONS: Continue on 8 1/2" x 11" page if additional space is needed. 7. Use this report to indicate deficiencies, problems and recommendations relating to publications. 8. For CLASSIFIED TMDERs see OPNAVINST 5510H for mailing requirements. 9. For TMDERs that affect more than one publication, submit a separate TMDER for each. 4. Submit TMDERs at web site http://nsdsa.phdnswc.navy.mil or mail to: COMMANDER, CODE 310 TMDER BLDG 1388, NAVSURFWARCENDIV NSDSA, 4363 MISSILE WAY, PORT HUENEME CA 93043-4307			
1. PUBLICATION NUMBER SS521-AH-PRO-010	2. VOL/PART	3. REV/DATE OR CHG/DATE REVISION 1	4. SYSTEM/EQUIPMENT ID
5. TITLE OF PUBLICATION U.S. Navy Diving Umbilical (UBA Mk 20 and Mk 21) Description, Materials and Assembly		6. REPORT CONTROL NUMBER (6 digit UIC-YY-any four: xxxxxx-03-xxxx)	
7. RECOMMEND CHANGES TO PUBLICATION			
7a. Page #	7b. Para #	7c. RECOMMENDED CHANGES AND REASONS	
8. ORIGINATOR'S NAME AND WORK CENTER		9. DATE	10. ORIGINATOR'S E-MAIL ADDRESS
11. TMMA of Manual (NSDSA will complete)			
12. SHIP OR ACTIVITY Name and Address (Include UIC/CAGE/HULL)		13. Phone Numbers:	
		Commercial () ___ - ___	
		DSN ___ - ___	
		FAX () ___ - ___	