



**DEPARTMENT OF THE NAVY**

NAVAL SEA SYSTEMS COMMAND  
1333 ISAAC HULL AVE SE  
WASHINGTON NAVY YARD DC 20376-0001

IN REPLY TO

10560  
Ser 00C3/3080  
8 May 2003

From: Commander, Naval Sea Systems Command (SEA 00C)  
To: Distribution

Subj: APPROVAL OF OPERATION AND MAINTENANCE MANUAL FOR  
MK 3 MOD 0 LIGHTWEIGHT DIVE SYSTEM (LWDS) REVISION 2

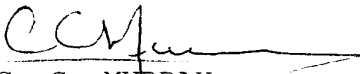
Ref: (a) Operation and Maintenance Instructions; Organizational  
Level for Lightweight Dive System (LWDS) MK 3 MOD 0,  
SS500-HK-MMO-010 Revision 1 dated 31 July 1998

(b) Operation and Maintenance Instructions; Organizational  
Level for Lightweight Dive System (LWDS) MK 3 MOD 0,  
SS500-HK-MMO-010 Revision 2 dated 07 May 2003

1. The operation and maintenance manual for MK 3 MOD 0  
Lightweight Dive System (LWDS), reference (a), has been revised  
and issued as reference (b).

2. Reference (b) is now approved for use by all commands. The  
operating and emergency procedures (OPS/EPS) included in  
reference (b) are approved and shall be used in all LWDS diving  
operations. All earlier versions of the LWDS operation and  
maintenance manual shall be discarded upon receipt of this  
manual.

3. NAVSEA point of contact for LWDS is Mr. Bob Kilpatrick, SEA  
00C33, (202) 781-4359, DSN 326-4359.

  
C. C. MURRAY

By direction

# SS500-HK-MMO-010

---

REVISION 2

TECHNICAL MANUAL  
OPERATION AND MAINTENANCE MANUAL  
ORGANIZATIONAL LEVEL  
LIGHTWEIGHT DIVE SYSTEM (LWDS)  
MK 3 MOD 0

0910-LP-101-9965

N61331-01-D-0018



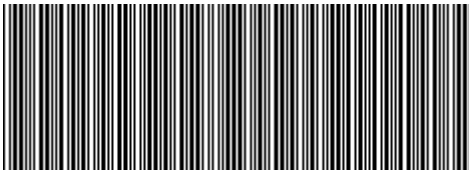
THIS PUBLICATION SUPERSEDES REVISION 1 OF  
NAVSEA SS500-HK-MMO-010, DATED 31 JULY 1998.

DISTRIBUTION STATEMENT A: APPROVED FOR PUBLIC RELEASE; DISTRIBUTION IS UNLIMITED.

---

PUBLISHED BY DIRECTION OF COMMANDER, NAVAL SEA SYSTEMS COMMAND

---



0910-LP-101-9965

# SS500-HK-MMO-010

---

---

SS500-HK-MMO-010 — REVISION 2  
**LIGHTWEIGHT DIVE SYSTEM (LWDS) MK 3 MOD 0**

---

SS500-HK-MMO-010 — REVISION 2  
**LIGHTWEIGHT DIVE SYSTEM (LWDS) MK 3 MOD 0**

---

SS500-HK-MMO-010 — REVISION 2  
**LIGHTWEIGHT DIVE SYSTEM (LWDS) MK 3 MOD 0**

# SS500-HK-MMO-010

---

REVISION 2

TECHNICAL MANUAL  
OPERATION AND MAINTENANCE MANUAL  
ORGANIZATIONAL LEVEL  
LIGHTWEIGHT DIVE SYSTEM (LWDS)  
MK 3 MOD 0

0910-LP-101-9965

N61331-01-D-0018



THIS PUBLICATION SUPERSEDES REVISION 1 OF  
NAVSEA SS500-HK-MMO-010, DATED 31 JULY 1998.

DISTRIBUTION STATEMENT A: APPROVED FOR PUBLIC RELEASE; DISTRIBUTION IS UNLIMITED.

---

PUBLISHED BY DIRECTION OF COMMANDER, NAVAL SEA SYSTEMS COMMAND

07 MAY 2003

## SS500-HK-MMO-010

## LIST OF EFFECTIVE PAGES

INSERT LATEST CHANGED PAGES. DESTROY SUPERSEDED PAGES.

NOTE: The portion of the text affected by a change is indicated by a vertical line in the outer margin of the page. Changes to illustrations are indicated by miniature pointing hands (✎). Changes to diagrams are indicated by shaded areas.

Date of issue for original pages is:

Revision 2 . . . . . 0 . . . . . 07 May 2003

TOTAL NUMBER OF PAGES IN THIS PUBLICATION IS 480, CONSISTING OF THE FOLLOWING:

Page No.	*Change No.	Page No.	*Change No.
Title . . . . .	0	Appendix B Title . . . . .	0
A . . . . .	0	B-0 thru B-11 . . . . .	0
B Blank . . . . .	0	B-12 Blank . . . . .	0
(Change Record 1) . . . . .	0	B-13 thru B-23 . . . . .	0
(Change Record 2 Blank) . . . . .	0	B-24 Blank . . . . .	0
i thru xi . . . . .	0	B-25 thru B-31 . . . . .	0
xii Blank . . . . .	0	B-32 Blank . . . . .	0
xiii thru xx . . . . .	0	B-33 thru B-39 . . . . .	0
Blank . . . . .	0	B-40 Blank . . . . .	0
1-0 thru 1-12 . . . . .	0	Appendix C Title . . . . .	0
2-1 thru 2-39 . . . . .	0	Blank . . . . .	0
2-40 Blank . . . . .	0	C-1 thru C-2 . . . . .	0
2-41 thru 2-43 . . . . .	0	Appendix D Title . . . . .	0
2-44 Blank . . . . .	0	Blank . . . . .	0
2-45 thru 2-49 . . . . .	0	D-1 . . . . .	0
2-50 Blank . . . . .	0	D-2 Blank . . . . .	0
2-51 thru 2-57 . . . . .	0	D-3 . . . . .	0
2-58 Blank . . . . .	0	D-4 Blank . . . . .	0
2-59 . . . . .	0	D-5 . . . . .	0
2-60 Blank . . . . .	0	D-6 Blank . . . . .	0
2-61 thru 2-68 . . . . .	0	D-7 . . . . .	0
3-1 thru 3-16 . . . . .	0	D-8 Blank . . . . .	0
4-1 thru 4-8 . . . . .	0	D-9 thru D-11 . . . . .	0
5-1 thru 5-11 . . . . .	0	D-12 Blank . . . . .	0
5-12 Blank . . . . .	0	D-13 thru D-15 . . . . .	0
6-1 thru 6-90 . . . . .	0	D-16 Blank . . . . .	0
7-1 thru 7-34 . . . . .	0	Appendix E Title . . . . .	0
8-1 thru 8-4 . . . . .	0	Blank . . . . .	0
Appendix A Title . . . . .	0	E-1 . . . . .	0
Blank . . . . .	0	E-2 Blank . . . . .	0
A-1 thru A-13 . . . . .	0	Appendix F Title . . . . .	0
A-14 Blank . . . . .	0	Blank . . . . .	0
A-15 thru A-49 . . . . .	0	F-1 thru F-2 . . . . .	0
A-50 Blank . . . . .	0	(75-page insert) . . . . .	0
A-51 thru A-60 . . . . .	0		

\* Zero in this column indicates an original page.

THIS PAGE INTENTIONALLY LEFT BLANK

SS500-HK-MMO-010

**RECORD OF CHANGES**

Change No.	Date	Title and/or Brief Description	Signature of Validating Officer



THIS PAGE INTENTIONALLY LEFT BLANK

SS500-HK-MMO-010

## **APPROVAL PAGE**

**Changes to the Lightweight Dive System (LWDS) MK 3 Mod 0 Operation and Maintenance Manual, NAVSEA SS500-HK-MMO-010, require NAVSEA review and approval.**

1. Revision 2 of NAVSEA SS500-HK-MMO-010, dated 07 May 2003, is approved by NAVSEA letter Ser 00C3/3080, dated 8 May 2003.

THIS PAGE INTENTIONALLY LEFT BLANK

## SS500-HK-MMO-010

**TABLE OF CONTENTS**

<u>Chapter/Paragraph</u>	<u>Page</u>
List of Illustrations .....	vii
List of Tables .....	x
Foreword .....	xiii
List of Acronyms and Abbreviations .....	xiv
Safety Summary .....	xv
<b>1 GENERAL INFORMATION AND SAFETY PRECAUTIONS</b>	
1.1 Safety Precautions .....	1-1
1.2 Introduction .....	1-1
1.3 Physical Arrangement .....	1-2
1.3.1 Configuration 1 .....	1-2
1.3.2 Configuration 2 .....	1-2
1.3.3 Configuration 3 .....	1-5
1.4 System Equipment .....	1-5
1.4.1 Diesel-Compressor Assembly .....	1-5
1.4.2 Primary HP Air Supply .....	1-7
1.4.3 Volume Tank Assembly .....	1-7
1.4.4 Control Console Assembly .....	1-8
1.4.5 Secondary HP Air Supply .....	1-8
1.4.6 Roof Rack Assembly .....	1-8
1.4.7 Interconnecting Hose Assemblies .....	1-8
1.5 Reference Data .....	1-9
<b>2 OPERATION</b>	
2.1 Introduction .....	2-1
2.2 Preoperational Conditions and Setup .....	2-1
2.2.1 Equipment Checklist .....	2-1
2.2.2 Initial Control and Indicator Settings .....	2-3
2.3 Operating Procedures .....	2-12
2.3.1 Prepermission Procedures: Equipment Setup .....	2-13
2.3.2 Pre-dive Start-Up: Configuration 1, Primary Air .....	2-27
2.3.3 Pre-dive Start-Up: Configuration 1, Secondary Air .....	2-31
2.3.4 Pre-dive Start-Up: Configurations 2 and 3, Primary Air .....	2-33
2.3.5 Pre-dive Start-up: Configurations 2 and 3, Secondary Air .....	2-37
2.3.6 Modified Start-Up Procedure .....	2-41
2.3.7 Pre-dive/Postdive: HP Flask Charging Procedure .....	2-45
2.3.8 Pre-dive Start-Up: Diver Equipment .....	2-49
2.3.9 During OPs: HP Flask Charging Procedure .....	2-51
2.3.10 Postdive Shutdown Procedures: Configurations 1, 2, and 3 .....	2-53
2.3.11 Modified Shutdown Procedure: Configurations 1, 2, and 3 .....	2-59
2.3.12 Postmission Procedures: Configurations 1, 2, and 3 .....	2-61

## SS500-HK-MMO-010

**TABLE OF CONTENTS—Continued**

<u>Chapter/Paragraph</u>	<u>Page</u>
2.4 Emergency Procedure .....	2-65
2.5 Failure Analysis Reporting .....	2-65
2.6 Accident/Incident Equipment Status Reporting .....	2-66

**3 FUNCTIONAL DESCRIPTION**

3.1 Introduction .....	3-1
3.2 LWDS Breathing System .....	3-1
3.2.1 Primary Air Source .....	3-1
3.2.1.1 Configuration 1 .....	3-1
3.2.1.2 Configurations 2 and 3 .....	3-6
3.2.2 Secondary Air Source .....	3-6
3.3 LWDS Equipment Functions .....	3-6
3.3.1 Diesel-Compressor Assembly .....	3-6
3.3.1.1 Diesel Engine .....	3-6
3.3.1.2 Compressor .....	3-6
3.3.1.3 Snorkel Assembly .....	3-8
3.3.2 Primary HP Air Supply .....	3-8
3.3.3 Volume Tank Assembly .....	3-8
3.3.3.1 Volume Tank .....	3-8
3.3.3.2 Filters .....	3-8
3.3.4 Control Console Assembly .....	3-11
3.3.5 Secondary HP Air Supply .....	3-11
3.3.6 Roof Rack Assembly .....	3-11
3.3.7 Interconnecting Hose Assemblies .....	3-14
3.3.7.1 H-101—Volume Tank to Control Console Hose Assembly .....	3-14
3.3.7.2 H-102—Primary HP Air to Volume Tank or Secondary HP Air to Control Console Hose Assembly .....	3-14
3.3.7.3 H-104—Diesel-Compressor to Volume Tank Hose Assembly .....	3-14
3.3.7.4 H-105—Primary HP Air to Primary HP Air Hose Assembly .....	3-16
3.3.7.5 Flask Rack Interconnecting Hose Assemblies .....	3-16

**4 SCHEDULED MAINTENANCE**

4.1 Introduction .....	4-1
4.1.1 Purpose .....	4-1
4.1.2 Scope .....	4-1
4.2 System Certification and Re-Entry Control (REC) .....	4-1
4.3 Recordkeeping and Reporting Procedures .....	4-3
4.4 General Safety Requirements .....	4-3

## SS500-HK-MMO-010

**TABLE OF CONTENTS—Continued**

<u>Chapter/Paragraph</u>	<u>Page</u>
4.5 Maintenance Concept .....	4-4
4.5.1 Scheduled Maintenance .....	4-4
4.5.2 Unscheduled Maintenance .....	4-4
4.6 Planned Maintenance System (PMS) .....	4-4
4.7 General Maintenance Instructions .....	4-4
4.7.1 Tools, Supplies, and Test Equipment .....	4-4
4.7.2 Disassembly and Replacement of Parts .....	4-5
4.7.3 Cleaning and Leak Detection .....	4-6
4.7.3.1 Cleaning Breathing Air System Components .....	4-6
4.7.3.2 Precleaning and Leak Detection .....	4-6
4.7.3.3 Final Cleaning .....	4-7
4.7.4 Teflon® Tape .....	4-7
4.7.5 Lubricants .....	4-7
4.7.6 O-rings and Packings .....	4-7
4.7.6.1 Removal .....	4-7
4.7.6.2 Inspection .....	4-7
4.7.6.3 Cleaning and Lubrication .....	4-7
4.7.6.4 Installation .....	4-8
<b>5 TROUBLESHOOTING</b>	
5.1 Introduction .....	5-1
5.2 Troubleshooting Analysis .....	5-1
<b>6 CORRECTIVE MAINTENANCE</b>	
6.1 Introduction .....	6-1
6.2 Safety Requirements .....	6-1
6.3 Adjustments and Alignments .....	6-2
6.3.1 Adjusting Drive Belt Tension .....	6-2
6.3.2 Aligning Pulleys .....	6-3
6.3.3 Adjusting Diesel Engine Speed .....	6-3
6.3.4 Setting Fuel Pump Timing .....	6-4
6.3.5 Setting Fuel Pump and Governor Distances .....	6-4
6.3.6 Setting Governor Speed Spring Tension .....	6-5
6.3.7 Adjusting Valve to Rocker Clearance .....	6-5
6.3.8 Adjusting Decompressors .....	6-6
6.3.9 Adjusting Compressor Pilot Valve (ALP-V403) .....	6-7
6.3.10 Adjusting Valve Packing .....	6-8
6.4 General Repair Information .....	6-9
6.4.1 Maintenance Parts .....	6-9
6.4.2 Related Maintenance .....	6-10

## SS500-HK-MMO-010

**TABLE OF CONTENTS—Continued**

<u>Chapter/Paragraph</u>	<u>Page</u>
6.5 Tools and Support Equipment .....	6-10
6.5.1 Tools .....	6-10
6.5.2 Special Tools .....	6-11
6.5.3 Support Equipment .....	6-11
6.6 Torque Values .....	6-11
6.7 Consumable Supplies .....	6-11
6.8 Corrective Maintenance Procedures .....	6-13
6.8.1 Diesel Engine .....	6-16
6.8.1.1 Cylinder Head Covers .....	6-16
6.8.1.2 Fuel Pumps .....	6-19
6.8.1.3 Fuel Injectors .....	6-21
6.8.1.4 Exhaust Muffler .....	6-23
6.8.2 Air Compressor .....	6-26
6.8.2.1 Drive Belt .....	6-26
6.8.2.2 Relief Valve .....	6-27
6.8.2.3 Unloader Valve .....	6-27
6.8.2.4 Vent Valve .....	6-28
6.8.2.5 Ball Valves (ALP-V401, ALP-V405) .....	6-29
6.8.2.6 Plug Valve (ALP-V402) .....	6-31
6.8.2.7 Pilot Valve (ALP-V403) .....	6-31
6.8.2.8 LP Relief Valve (ALP-V404) .....	6-34
6.8.2.9 LP Pressure Gauge (ALP-G406) .....	6-36
6.8.3 HP Air Supply and Roof Rack Assembly .....	6-38
6.8.3.1 HP Air Flasks .....	6-38
6.8.3.2 HP Isolation Valves (AHP-V501, AHP-V502, AHP-V503, AHP-V504) .....	6-42
6.8.3.3 Flask Shutoff Valves (AHP-V505, AHP-V506, AHP-V507) .....	6-46
6.8.3.4 HP Pressure Gauges (AHP-G508, AHP-G602) .....	6-47
6.8.3.5 HP Isolation Valve (AHP-V601) .....	6-49
6.8.3.6 HP Relief Valve (AHP-V603) .....	6-52
6.8.3.7 HP Isolation Valve (AHP-V604) .....	6-54
6.8.4 Volume Tank Assembly .....	6-57
6.8.4.1 HP Regulator (AHP-V201) .....	6-57
6.8.4.2 HP Gauge Isolation Valve (AHP-V202) .....	6-64
6.8.4.3 LP Gauge Isolation Valve (ALP-V204) .....	6-67
6.8.4.4 Plug Valves (ALP-V205, ALP-V208, ALP-V209) .....	6-68
6.8.4.5 Check Valve (ALP-V206) .....	6-69
6.8.4.6 LP Relief Valves (ALP-V207, ALP-V211) .....	6-70
6.8.4.7 Ball Valve (ALP-V210) .....	6-71
6.8.4.8 Mod 0 and Mod 1 HP Pressure Gauges (AHP-G211) ...	6-72
6.8.4.9 LP Pressure Gauge (ALP-G212) .....	6-73

## SS500-HK-MMO-010

**TABLE OF CONTENTS—Continued**

<u>Chapter/Paragraph</u>	<u>Page</u>
6.8.5 Control Console Assembly .....	6-75
6.8.5.1 Control Console Panel .....	6-75
6.8.5.2 LP Gauge Isolation Valves (ALP-V301, ALP-V310, ALP-V312, ALP-V313, ALP-V314) .....	6-76
6.8.5.3 Ball Valve (ALP-V302) .....	6-77
6.8.5.4 Check Valve (ALP-V303) .....	6-78
6.8.5.5 Ball Valves (ALP-V304, ALP-V305, ALP-V306) .....	6-80
6.8.5.6 HP Regulator (AHP-V307) .....	6-80
6.8.5.7 LP Relief Valves (ALP-V308, ALP-V315) .....	6-86
6.8.5.8 HP Gauge Isolation Valve (AHP-V309) .....	6-87
6.8.5.9 LP Pressure Gauges (ALP-G315, ALP-G317) .....	6-87
6.8.5.10 Mod 0 and Mod 1 HP Pressure Gauges (AHP-G316) . . . .	6-88
6.8.5.11 Diver Depth Gauges (ALP-G318, ALP-G319, ALP-G320) .	6-88
<b>7 PARTS LISTS</b>	
7.1 Introduction .....	7-1
<b>8 INSTALLATION</b>	
8.1 Introduction .....	8-1
8.2 Inventory .....	8-1
8.3 Inspection .....	8-2
8.3.1 Diesel-Compressor Assembly .....	8-2
8.3.2 Snorkel Assembly .....	8-3
8.3.3 Volume Tank Assembly .....	8-3
8.3.4 Primary and Secondary HP Air Flasks .....	8-3
8.3.5 Control Console Assembly .....	8-3
8.3.6 Interconnecting Hoses .....	8-3
8.4 Initial Operational Test .....	8-4
8.5 Storage Requirements .....	8-4
8.5.1 Short-Term Storage .....	8-4
8.5.2 Long-Term Storage .....	8-4
8.5.3 Storage Precautions .....	8-4
<b>APPENDIX A OPERATING AND EMERGENCY PROCEDURE CHECKLISTS FOR THE LIGHTWEIGHT DIVE SYSTEM (LWDS) MK 3 MOD 0</b>	
OP-1 Permission Procedures: Equipment Setup .....	A-3
OP-2.1 Pre-dive Start-Up: Configuration 1, Primary Air .....	A-9
OP-2.2 Pre-dive Start-Up: Configuration 1, Secondary Air .....	A-15
OP-2.3 Pre-dive Start-Up: Configurations 2 and 3, Primary Air .....	A-17
OP-2.4 Pre-dive Start-Up: Configurations 2 and 3, Secondary Air .....	A-21



## SS500-HK-MMO-010

**TABLE OF CONTENTS—Continued**

<u>Chapter/Paragraph</u>		<u>Page</u>
OP-2M	Modified Start-Up Procedure . . . . .	A-25
OP-3	Prediver/Postdiver: HP Flask Charging Procedure . . . . .	A-29
OP-4	Prediver Start-Up: Diver Equipment . . . . .	A-33
OP-5	During OPs: HP Flask Charging Procedure . . . . .	A-35
OP-6	Postdiver Shutdown Procedures: Configurations 1, 2, and 3 . . . . .	A-37
OP-6M	Modified Shutdown Procedure: Configurations 1, 2, and 3 . . . . .	A-43
OP-7	Postmission Procedures: Configurations 1, 2, and 3 . . . . .	A-45
EP-1	Emergency Procedure: Loss of Primary Air . . . . .	A-51

**APPENDIX B LIGHTWEIGHT DIVE SYSTEM (LWDS) MK 3 MOD 1**

B.1	Introduction . . . . .	B-1
B.2	Functional Description . . . . .	B-1
B.3	Reference Data . . . . .	B-2
B.4	Safety Precautions . . . . .	B-2
B.5	Equipment Checklist . . . . .	B-3
B.6	Controls and Indicators . . . . .	B-4
B.7	Operation . . . . .	B-4
B.8	Scheduled/Corrective Maintenance and Troubleshooting . . . . .	B-8
B.9	Parts Lists . . . . .	B-8
B.10	Installation . . . . .	B-8
B.11	Operating and Emergency Procedures . . . . .	B-9
OP-8	LWDS MK 3 Mod 1 Prepermission Setup Procedures . . . . .	B-13
OP-9	LWDS MK 3 Mod 1 Prediver Start-Up Procedures . . . . .	B-19
OP-9M	LWDS MK 3 Mod 1 Modified Prediver Start-Up Procedures . . . . .	B-25
OP-10	LWDS MK 3 Mod 1 Postdiver Shutdown Procedures . . . . .	B-29
OP-10M	LWDS MK 3 Mod 1 Modified Postdiver Shutdown Procedures . . . . .	B-33
OP-11	LWDS MK 3 Mod 1 Postmission Procedures . . . . .	B-35
EP-2	LWDS MK 3 Mod 1 Emergency Procedure: Loss of Primary Air . . . . .	B-39

**APPENDIX C INTERNAL INSPECTION PROCEDURES FOR KEVLAR® AND CARBON FIBER HP AIR FLASKS**

C.1	Introduction . . . . .	C-1
C.2	Internal Inspection of Primary and Secondary HP Air Flasks . . . . .	C-1
C.3	Condemnation and Disposal of Flasks . . . . .	C-2

**APPENDIX D EXTERNAL INSPECTION PROCEDURES FOR KEVLAR® HP AIR FLASKS**

D.1	Introduction . . . . .	D-1
D.2	External Inspection of Primary and Secondary HP Air Flasks . . . . .	D-1
D.2.1	Types of External Damage . . . . .	D-1

## SS500-HK-MMO-010

**TABLE OF CONTENTS—Continued**

<u>Chapter/Paragraph</u>	<u>Page</u>
D.2.2 Levels of External Damage .....	D-9
D.2.3 External Inspection Criteria .....	D-9
D.2.4 Hydrostatic Testing .....	D-14
D.2.5 Manufacturer's Label .....	D-15
<b>APPENDIX E EXTERNAL INSPECTION PROCEDURES FOR CARBON FIBER HP AIR FLASKS</b>	
E.1 Introduction .....	E-1
E.2 External Inspection of Primary and Secondary HP Air Flasks .....	E-1
<b>APPENDIX F U.S. DEPARTMENT OF TRANSPORTATION (DOT) COMPOSITE FLASK EXEMPTIONS AND ASSOCIATED DOCUMENTS</b>	
F.1 Introduction .....	F-1
F.2 Composite Flask Exemptions .....	F-1
F.3 Associated Documents .....	F-2

**LIST OF ILLUSTRATIONS**

<u>Figure</u>	<u>Title</u>	<u>Page</u>
1-1	Overview of the Lightweight Dive System (LWDS) MK 3 Mod 0 .....	1-0
1-2	Lightweight Dive System (LWDS) MK 3 Mod 0, Configuration 1 .....	1-3
1-3	Lightweight Dive System (LWDS) MK 3 Mod 0, Configuration 2 .....	1-4
1-4	Lightweight Dive System (LWDS) MK 3 Mod 0, Configuration 3 .....	1-6
1-5	Multiple Stacks of Flask Racks, Configuration 3 .....	1-7
2-1	Diesel-Compressor Assembly with Snorkel Assembly .....	2-4
2-2	Diesel-Compressor Assembly (Right Side View) .....	2-5
2-3	Secondary HP Air Supply, Configuration 1 .....	2-6
2-4	Primary and Secondary HP Air Supplies, Configuration 2 .....	2-7
2-5	Primary and Secondary HP Air Supplies, Configuration 3 .....	2-8
2-6	Volume Tank Assembly .....	2-9
2-7	Control Console Assembly .....	2-11
2-8	Operating and Emergency Procedures Flow Chart .....	2-12
2-9	Lightweight Dive System (LWDS) MK 3 Mod 0, Configuration 1 .....	2-15
2-10	LWDS MK 3 Mod 0 Schematic, Configuration 1 .....	2-16
2-11	Lightweight Dive System (LWDS) MK 3 Mod 0, Configuration 2 .....	2-18
2-12	LWDS MK 3 Mod 0 Schematic, Configuration 2 .....	2-19
2-13	Lightweight Dive System (LWDS) MK 3 Mod 0, Configuration 3 .....	2-20
2-14	LWDS MK 3 Mod 0 Schematic, Configuration 3 .....	2-21

## SS500-HK-MMO-010

**LIST OF ILLUSTRATIONS—Continued**

<u>Figure</u>	<u>Title</u>	<u>Page</u>
2-15	Lightweight Dive System (LWDS) MK 3 Mod 0, Multiple Stacks of Flask Racks, Configuration 3 . . . . .	2-23
2-16	LWDS MK 3 Mod 0 Schematic, Multiple Stacks of Flask Racks, Configuration 3 . . . . .	2-24
2-17	Fuel and Lubrication Chart . . . . .	2-28
2-18	Failure Analysis Report (FAR) Form . . . . .	2-67
3-1	LWDS MK 3 Mod 0 Functional Diagram, Configuration 1 . . . . .	3-2
3-2	LWDS MK 3 Mod 0 Functional Diagram, Configuration 2 . . . . .	3-3
3-3	LWDS MK 3 Mod 0 Functional Diagram, Configuration 3 . . . . .	3-4
3-4	LWDS MK 3 Mod 0 Functional Diagram, Multiple Stacks of Flask Racks, Configuration 3 . . . . .	3-5
3-5	Diesel-Compressor Assembly with Snorkel Assembly . . . . .	3-7
3-6	Primary and Secondary HP Air Supplies, Configuration 2 . . . . .	3-9
3-7	Volume Tank Assembly . . . . .	3-10
3-8	Control Console Assembly . . . . .	3-12
3-9	Secondary HP Air Supply with Roof Rack Assembly, Configuration 1 . . . . .	3-13
3-10	Interconnecting Hose Assemblies . . . . .	3-15
4-1	LWDS MK 3 Mod 0 Certification Boundaries, Configuration 1 . . . . .	4-2
6-1	Engine Speed Adjustment Mechanism . . . . .	6-3
6-2	Pilot Valve (ALP-V403) . . . . .	6-7
6-3	Cylinder Head Covers . . . . .	6-17
6-4	Removing Swivel Union Plug and Lubricating Oil Pipe . . . . .	6-18
6-5	Fuel Pumps . . . . .	6-20
6-6	Fuel Injectors . . . . .	6-22
6-7	Diesel-Compressor Assembly Parts Location . . . . .	6-24
6-8	Ball Valves (ALP-V401, -V405) . . . . .	6-30
6-9	Pilot Valve (ALP-V403) . . . . .	6-32
6-10	LP Relief Valve (ALP-V404) . . . . .	6-35
6-11	LP Pressure Gauge (ALP-G406) . . . . .	6-37
6-12	Flask Removal . . . . .	6-40
6-13	Circle Seal HP Isolation Valves (AHP-V501 thru AHP-V504 and AHP-V601)	6-42
6-14	CPV HP Isolation Valves (AHP-V501 thru AHP-V504 and AHP-V601) . . . . .	6-44
6-15	Flask Shutoff Valves (AHP-V505, -V506, -V507) and Softseat . . . . .	6-47
6-16	HP Pressure Gauges (AHP-G211, -G316, -G508, and -G602) . . . . .	6-48
6-17	HP Relief Valve (AHP-V603) . . . . .	6-53
6-18	HP Isolation Valve (AHP-V604) and LP Gauge Isolation Valves (ALP-V204, -V301, -V310, -V312, -V313, and -V314) . . . . .	6-55
6-19	Circle Seal HP Regulators (AHP-V201, -V307) . . . . .	6-58
6-20	Location of Parts Attached to Regulator (AHP-V201) . . . . .	6-59
6-21	Tescom HP Regulators (AHP-V201, -V307) . . . . .	6-62
6-22	HP Gauge Isolation Valves (AHP-V202, -V309) . . . . .	6-65
6-23	Ball Valves (ALP-V210, -V304, -V305, -V306) . . . . .	6-72

## SS500-HK-MMO-010

**LIST OF ILLUSTRATIONS—Continued**

<u>Figure</u>	<u>Title</u>	<u>Page</u>
6-24	LP Pressure Gauges (ALP-G212, -G315, -G317) . . . . .	6-73
6-25	Ball Valve (ALP-V302) . . . . .	6-78
6-26	Location of Parts Attached to Regulator (AHP-V307) . . . . .	6-81
6-27	Diver Depth Gauges (ALP-G318, -G319, -G320) . . . . .	6-89
7-1	Cylinder Head Covers (Diesel Engine) . . . . .	7-3
7-2	Air Filter Element (Diesel Engine) . . . . .	7-4
7-3	Fuel Filter (Diesel Engine) . . . . .	7-4
7-4	Fuel Pump (Diesel Engine) . . . . .	7-5
7-5	Fuel Injector (Diesel Engine) . . . . .	7-5
7-6	Exhaust Muffler (Diesel Engine) . . . . .	7-6
7-7	Drive Belt (Air Compressor to Diesel Engine) . . . . .	7-6
7-8	Snorkel Filter Element (Snorkel Assembly) . . . . .	7-7
7-9	Air Filter (Air Compressor) . . . . .	7-7
7-10	Moisture Separator (Air Compressor) . . . . .	7-8
7-11	Relief Valve (Air Compressor) . . . . .	7-9
7-12	Unloader Valve (Air Compressor) . . . . .	7-9
7-13	Vent Valve (Air Compressor) . . . . .	7-10
7-14	Hose Nipple and Softseat (HP Hose Assembly) . . . . .	7-10
7-15	Filter Element (Volume Tank) . . . . .	7-11
7-16	HP Supply Air Filter (Volume Tank) . . . . .	7-11
7-17	Diver Depth Gauges (ALP-G318, -G319, -G320) . . . . .	7-12
7-18	HP Pressure Gauges (AHP-G211, -G316, -G508, -G602) . . . . .	7-12
7-19	LP Pressure Gauges (ALP-G212, -G315, -G317) . . . . .	7-13
7-20	LP Pressure Gauge (ALP-G406) . . . . .	7-13
7-21	Ball Valves (ALP-V210, -V304, -V305, -V306) . . . . .	7-14
7-22	Ball Valve (ALP-V302) . . . . .	7-15
7-23	Ball Valves (ALP-V401, -V405) . . . . .	7-16
7-24	Check Valves (ALP-V206, -V303) . . . . .	7-17
7-25	Flask Shutoff Valves (AHP-V505, -V506, -V507) . . . . .	7-18
7-26	HP Gauge Isolation Valves (AHP-V202, -V309) . . . . .	7-19
7-27	LP Gauge Isolation Valves (ALP-V204, -V301, -V310, -V312, -V313, -V314) and HP Isolation Valve (AHP-V604) . . . . .	7-20
7-28	CPV HP Isolation Valves (AHP-V501, -V502, -V503, -V504, -V601) . . . . .	7-22
7-29	Circle Seal HP Isolation Valves (AHP-V501, -V502, -V503, -V504, -V601) . . . . .	7-24
7-30	Pilot Valve (ALP-V403) . . . . .	7-24
7-31	Plug Valves (ALP-V205, -V208, -V209, -V402) . . . . .	7-25
7-32	LP Relief Valves (ALP-V207, -V211, -V308, -V315) . . . . .	7-26
7-33	Circle Seal HP Regulators (AHP-V201, -V307) . . . . .	7-27
7-34	Tescom HP Regulators (AHP-V201, -V307) . . . . .	7-28
7-35	LP Relief Valve (ALP-V404) . . . . .	7-30
7-36	HP Relief Valve (AHP-V603) . . . . .	7-31
7-37	Composite Flasks . . . . .	7-32
7-38	Volume Tank Inspection Port Plug O-rings . . . . .	7-32

## SS500-HK-MMO-010

**LIST OF ILLUSTRATIONS—Continued**

<u>Figure</u>	<u>Title</u>	<u>Page</u>
A-1	Lightweight Dive System (LWDS) MK 3 Mod 0, Configuration 1 . . . . .	A-52
A-2	LWDS MK 3 Mod 0 Schematic, Configuration 1 . . . . .	A-53
A-3	Lightweight Dive System (LWDS) MK 3 Mod 0, Configuration 2 . . . . .	A-54
A-4	LWDS MK 3 Mod 0 Schematic, Configuration 2 . . . . .	A-55
A-5	Lightweight Dive System (LWDS) MK 3 Mod 0, Configuration 3 . . . . .	A-56
A-6	LWDS MK 3 Mod 0 Schematic, Configuration 3 . . . . .	A-57
A-7	Lightweight Dive System (LWDS) MK 3 Mod 0, Multiple Stacks of Flask Racks, Configuration 3 . . . . .	A-58
A-8	LWDS MK 3 Mod 0 Schematic, Multiple Stacks of Flask Racks, Configuration 3 . . . . .	A-59
A-9	Fuel and Lubrication Chart . . . . .	A-60
B-1	Typical LWDS MK 3 Mod 1 Configuration (Shown Supporting Divers Wearing UBA MK 21 Mod 1 Helmets) . . . . .	B-0
B-2	LWDS MK 3 Mod 1 Volume Tank Assembly . . . . .	B-5
B-3	LWDS MK 3 Mod 1 Control Console Assembly . . . . .	B-7
B-4	LWDS MK 3 Mod 1 Operating and Emergency Procedures Flow Chart . . . . .	B-11
D-1	Flask Scuffs . . . . .	D-1
D-2	Flask Abrasions . . . . .	D-3
D-3	Flask Cuts . . . . .	D-5
D-4	Flask Dents . . . . .	D-7
D-5	Flask Delamination . . . . .	D-7
D-6	Flask Structural Damage . . . . .	D-11
D-7	Flask Fire Damage . . . . .	D-11

**LIST OF TABLES**

<u>Table</u>	<u>Title</u>	<u>Page</u>
1-1	LWDS MK 3 Mod 0 Physical Characteristics . . . . .	1-9
1-2	Equipment, Accessories, and Documents Supplied . . . . .	1-10
1-3	Referenced Documents . . . . .	1-10
2-1	LWDS MK 3 Mod 0 Equipment Checklist - Configuration 1 . . . . .	2-2
2-2	LWDS MK 3 Mod 0 Equipment Checklist - Configurations 2 and 3 . . . . .	2-2
2-3	Diesel-Compressor Assembly Controls and Indicators . . . . .	2-3
2-4	Primary and Secondary HP Air Supply Controls and Indicators . . . . .	2-6
2-5	Volume Tank Assembly Controls and Indicators . . . . .	2-9
2-6	Control Console Assembly Controls and Indicators . . . . .	2-10
2-7	Prepermission Procedures: Equipment Setup . . . . .	2-13
2-8	Pre-dive Start-Up: Configuration 1, Primary Air . . . . .	2-27
2-9	Pre-dive Start-Up: Configuration 1, Secondary Air . . . . .	2-31
2-10	Pre-dive Start-Up: Configurations 2 and 3, Primary Air . . . . .	2-33
2-11	Pre-dive Start-Up: Configurations 2 and 3, Secondary Air . . . . .	2-37

## SS500-HK-MMO-010

**LIST OF TABLES—Continued**

<u>Table</u>	<u>Title</u>	<u>Page</u>
2-12	Modified Start-Up Procedure .....	2-41
2-13	Pre-dive/Post-dive: HP Flask Charging Procedure .....	2-45
2-14	Pre-dive Start-Up: Diver Equipment .....	2-49
2-15	During OPs: HP Flask Charging Procedure .....	2-51
2-16	Post-dive Shutdown Procedures: Configurations 1, 2, and 3 .....	2-53
2-17	Modified Shutdown Procedure: Configurations 1, 2, and 3 .....	2-59
2-18	Post-mission Procedures: Configurations 1, 2, and 3 .....	2-61
2-19	Emergency Procedure: Loss of Primary Air .....	2-65
4-1	Periodicity Codes .....	4-5
5-1	Fault Isolation Index .....	5-2
5-2	Diesel Engine Fault Directory .....	5-3
5-3	Air Compressor Fault Directory .....	5-6
5-4	HP Air Supply and Roof Rack Assembly Fault Directory .....	5-8
5-5	Volume Tank Assembly Fault Directory .....	5-9
5-6	Control Console Assembly Fault Directory .....	5-10
6-1	Valve to Rocker Clearances .....	6-6
6-2	List of Recommended Tools .....	6-10
6-3	Special Tools .....	6-11
6-4	Torque Values .....	6-12
6-5	Consumable Supplies .....	6-13
6-6	Maintenance Reference Chart .....	6-14
7-1	LWDS MK 3 Mod 0 Replacement Parts Index .....	7-1
7-2	List of Manufacturers and Suppliers .....	7-33
8-1	LWDS MK 3 Mod 0 Initial Inventory .....	8-1
A-1	Index of Appendix A Procedures and Figures .....	A-1
B-1	LWDS MK 3 Mod 1 Physical Characteristics .....	B-3
B-2	Equipment, Accessories, and Documents .....	B-3
B-3	LWDS MK 3 Mod 1 Equipment Checklist .....	B-4
B-4	LWDS MK 3 Mod 1 Volume Tank Assembly Controls and Indicators .....	B-5
B-5	LWDS MK 3 Mod 1 Control Console Assembly Controls and Indicators .....	B-6
B-6	Index of LWDS MK 3 Mod 1 Operating and Emergency Procedures .....	B-9
D-1	Summary of External Inspection Criteria for Fully-Wound Composite Flasks .....	D-13

THIS PAGE INTENTIONALLY LEFT BLANK

SS500-HK-MMO-010

## FOREWORD

This technical manual contains operation and maintenance information and procedures for the Lightweight Dive System (LWDS) MK 3 Mod 0, and for components of the LWDS MK 3 Mod 1 that are common to both systems. Information unique to the LWDS MK 3 Mod 1 is contained in Appendix B. The information in this manual is presented in eight chapters and six appendices as follows:

- Chapter 1—General Information and Safety Precautions
- Chapter 2—Operation
- Chapter 3—Functional Description
- Chapter 4—Scheduled Maintenance
- Chapter 5—Troubleshooting
- Chapter 6—Corrective Maintenance
- Chapter 7—Parts Lists
- Chapter 8—Installation
- Appendix A—Operating and Emergency Procedure Checklists for the Lightweight Dive System (LWDS) MK 3 Mod 0
- Appendix B—Lightweight Dive System (LWDS) MK 3 Mod 1
- Appendix C—Internal Inspection Procedures for Kevlar® and Carbon Fiber HP Air Flasks
- Appendix D—External Inspection Procedures for Kevlar® HP Air Flasks
- Appendix E—External Inspection Procedures for Carbon Fiber HP Air Flasks
- Appendix F—U.S. Department of Transportation (DOT) Composite Flask Exemptions and Associated Documents

Ships, training activities, supply points, depots, Naval Shipyards, and Supervisors of Shipbuilding are requested to arrange for the maximum practical use and evaluation of Naval Sea Systems Command (NAVSEA) technical manuals. All errors, omissions, discrepancies, and suggestions for improvement to NAVSEA technical manuals shall be reported to:

COMMANDER  
NSDSA CODE 5E30  
NAVSURFWARCENDIV  
4363 MISSILE WAY  
PORT HUENEME CA 93043-4307

on NAVSEA/SPAWAR Technical Manual Deficiency/Evaluation Report (TMDER), form NAVSEA 4160/1. All feedback comments shall be thoroughly investigated and originators will be advised of action resulting therefrom. Three copies of form NAVSEA 4160/1 are included at the end of each separately bound technical manual 8½ x 11 inches or larger. Copies of form NAVSEA 4160/1 may be requisitioned from the Naval Systems Data Support Activity Code 5E30 at the above address. Users are encouraged to transmit deficiency submittals via the Naval Systems Data Support Activity Web page located at: <http://nsdsa.phdnswc.navy.gov/tmder/tmder.asp?vl=1>.

## ACKNOWLEDGMENT

This manual contains copyrighted photographs that were reprinted with permission from the Compressed Gas Association, Inc., publication no. CGA C-6.2, 1988, *Guidelines for Visual Inspection & Requalification of Fiber Reinforced High Pressure Cylinders*.



## SS500-HK-MMO-010

**LIST OF ACRONYMS AND ABBREVIATIONS**

°	..... Degree	mm	..... Millimeters
°C	..... Degree Celsius	MRC	..... Maintenance Requirement Card
°F	..... Degree Fahrenheit	N/A	..... Not Applicable
3-M	..... Maintenance Material Management	NAVOSH	..... Navy Occupational Safety and Health
ANU	..... Authorized for (U.S.) Navy Use	NAVSEA	..... Naval Sea Systems Command
APL	..... Allowance Parts List	NID	..... Nonionic Detergent
ASRA	..... Air Supply Rack Assembly	NOC	..... Navy Oxygen Cleaner
CAGE	..... Commercial and Government Entity (Code)	NPT	..... National Pipe Thread
CCA	..... Control Console Assembly (used in Appendix B only)	NSN	..... National Stock Number
CCW	..... Counterclockwise	OP	..... Operating Procedure
CGA	..... Compressed Gas Association	oz/gal	..... Ounces Per Gallon
CW	..... Clockwise	PMS	..... Planned Maintenance System
DOT	..... Department of Transportation	PN	..... Part Number
EP	..... Emergency Procedure	psi	..... Pounds Per Square Inch
FADS	..... Fly Away Dive System	psig	..... Pounds Per Square Inch Gauge
FAR	..... Failure Analysis Report	Qty	..... Quantity
fsw	..... Feet of Seawater	REC	..... Re-Entry/Reentry Control
ft·lb	..... Foot Pounds	REF	..... Reference
HP	..... High Pressure	rpm	..... Revolutions Per Minute
HPAC	..... High Pressure Air Compressor	scf	..... Standard Cubic Feet
ID	..... Inside Diameter	scfm	..... Standard Cubic Feet Per Minute
IMA	..... Intermediate Maintenance Activity	SS	..... Stainless Steel
in·lb	..... Inch Pounds	TDC	..... Top Dead Center
JID	..... Joint Identification Drawing	TL	..... Transfer Lock
LP	..... Low Pressure	TMDER	..... Technical Manual Deficiency/Evaluation Report
LWDS	..... Lightweight Dive System	TRC	..... Transportable Recompression Chamber
MEK	..... Methyl Ethyl Ketone	TRCS	..... Transportable Recompression Chamber System
MIP	..... Maintenance Index Page	UBA	..... Underwater Breathing Apparatus
		VTA	..... Volume Tank Assembly (used in Appendix B only)

SS500-HK-MMO-010

## SAFETY SUMMARY

### 1.0 GENERAL SAFETY GUIDELINES

Personnel using the Lightweight Dive System (LWDS) MK 3 Mod 0 or Mod 1 shall observe the safety precautions and procedures specified in this technical manual. Personnel must be thoroughly familiar with all safety practices and understand the potential hazards associated with the LWDS before using the system or performing maintenance on the equipment. The following safety guidelines apply to operation and maintenance procedures in general and do not appear elsewhere in this publication, except by reference. Personnel must understand and comply with these guidelines during operation and maintenance of the LWDS MK 3 Mod 0 or Mod 1.

**1.1 Standard Safety Precautions.** Personnel using this equipment shall comply with the Diving Safety and Planning Checklist and with the U.S. Navy standard diving safety procedures, as stated in the *U.S. Navy Diving Manual*, NAVSEA SS521-AG-PRO-010. Only approved replacement parts, lubricants, cleaning solutions, and sealants specified in this technical manual or in the Planned Maintenance System (PMS) for the LWDS MK 3 Mod 0/Mod 1 shall be used with this equipment. Practices such as substitution of parts or materials and omission or alteration of procedures stated herein are not authorized.

**1.2 Forces Afloat.** Forces afloat must also comply with the *Navy Occupational Safety and Health (NAVOSH) Program Manual for Forces Afloat*, OPNAVINST 5100.19 series.

**1.3 Shore Activities.** Shore activities must also comply with the *Navy Occupational Safety and Health Program Manual*, OPNAVINST 5100.23 series.

### 2.0 WARNINGS CONTAINED IN THIS MANUAL

The following warnings appear in the text of this manual and are repeated here for emphasis.

#### WARNINGS

**Divers and support personnel shall perform the operating procedures presented in this manual when using the LWDS. Failure to perform prescribed procedures may result in equipment failure and personnel injury or death. (page 2-1)**

**Adequately position, stabilize, and secure all equipment prior to operation as movement during operation could result in equipment damage and injury or death to personnel. (pages 2-13, A-3, B-13, and B-17)**

**Do not place the compressor intake near the exhaust of any other equipment. The diesel exhaust silencer must be downwind of the snorkel assembly. Failure to observe this warning could result in injury or death to personnel breathing the compressed air. (pages 2-14 and A-4)**

## SS500-HK-MMO-010

**WARNINGS**

**If the diesel-compressor assembly must operate in an enclosed space, provisions should be made for engine cooling, ventilation, noise, and diesel exhaust fume removal. Failure to comply with this warning may result in injury or death to personnel and damage to the equipment. (pages 2-14 and A-4)**

**Do not fill the fuel tank while it is mounted on the diesel-compressor assembly. The fuel tank shall be disconnected and moved away from the immediate vicinity of the diving equipment prior to refueling. Failure to observe this warning could result in a fuel spill, creating an immediate fire hazard and possibly causing contamination of the diving equipment, all of which could result in injury or death to personnel and damage to the equipment. (pages 2-27, 2-41, 2-53, A-9, A-25, and A-37)**

**The LWDS is designed to operate in ambient temperatures of 40°-100°F. When operating in temperatures below 40°F, the diesel-compressor assembly requires the use of special fuels and lubricants. Failure to use the prescribed diesel fuel and lubricating oils could result in injury or death to divers or support personnel and damage to the equipment. (pages 2-27, 2-41, 2-54, A-9, A-25, and A-37)**

**Allowing starter handle to rotate on the running shaft is dangerous and could result in injury or death to personnel. (pages 2-28, 2-42, A-10, and A-26)**

**For the following step, maintain a firm grip on the hose and point the free end away from personnel to avoid injury from flying debris. (pages 2-29, 2-30, 2-35, 2-43, 2-49, A-10, A-12, A-19, A-27, and A-33)**

**If volume tank pressure drops during this procedure, volume tank check valve (ALP-V206) is faulty and must be replaced. Failure to comply with this warning may result in injury or death to personnel and damage to equipment. (pages 2-29 and A-12)**

**DO NOT FULLY OPEN DIVER DEPTH VALVES (ALP-V312, ALP-V313, and ALP-V314). Failure to comply will damage the diver depth gauges and may cause injury to personnel. (pages 2-30, 2-35, A-13, A-20, B-23, and B-27)**

**Use only Authorized for Navy Use (ANU) approved HP compressors with moisture separators and filtration for charging LWDS HP air flasks. Refer to *Diving Equipment Authorized for U.S. Navy Use (ANU)* list for approved HP compressors. (pages 2-46, 2-51, A-30, and A-35)**

**Always connect a safety cable with the HP charging line from the charging station to the flask rack frame when charging. Failure to comply with this warning may cause injury or death to personnel. (pages 2-46, 2-51, A-30, and A-35)**

## SS500-HK-MMO-010

**WARNINGS**

**Never charge the lowest primary flask rack assembly in the breathing loop during a dive. Failure to comply with this warning may cause injury or death to divers.** (pages 2-51 and A-35)

**Before bleeding HP air, ensure all personnel are clear of area to avoid injury from flying debris. Operator must wear protective eye wear when bleeding system.** (pages 2-54, 2-56, A-38, A-40, and B-29)

**Before bleeding LP air, ensure all personnel are clear of area to avoid injury from flying debris. Operator must wear protective eye wear when bleeding system.** (pages 2-55, 2-56, A-38, A-40, and B-30)

**If primary supply pressure drops below minimum manifold pressure, immediately perform the procedure below. Failure to perform this procedure could result in injury or death to divers.** (pages 2-65, A-51, and B-39)

**Properly performed scheduled maintenance is essential to safe, dependable diving operations with the Lightweight Dive System (LWDS) MK 3 Mod 0. Omission or negligent performance of prescribed maintenance procedures could result in equipment failure and injury or death to personnel.** (page 4-1)

**Repair or replace worn or damaged parts immediately with authorized replacement parts. Failure of a system component during a dive may result in injury or death to the diver.** (page 4-5)

**DO NOT DISASSEMBLE COMPONENTS NOR LOOSEN OR TIGHTEN FITTINGS WHILE THE SYSTEM IS UNDER PRESSURE. Prior to performing maintenance, ensure HP air supply has been shut down and all pressure has been vented from the system. Exposure to escaping HP air may result in serious injury or death to personnel.** (page 4-5)

**Cleanliness is imperative in maintaining and handling the LWDS MK 3 Mod 0. All tools and parts must be kept free of oil, grease, rust, or other contamination. Foreign substances within an assembly may result in equipment failure and possible injury or death to the diver.** (page 4-6)

**Do not use freon, bleach, or trichloroethylene for cleaning. These agents are toxic and usage may result in injury or death to personnel and damage to equipment.** (page 4-6)

**Do not use Trisodium Phosphate (TSP) to clean aluminum or copper components. Use may result in equipment failure and personnel injury or death.** (page 4-6)

## SS500-HK-MMO-010

**WARNINGS**

**Ensure O-rings are in good condition before installation. Failure of an O-ring in any component may result in equipment damage, mission abort, or diver injury or death. (page 4-8)**

**Properly performed corrective maintenance is essential to safe, dependable diving operations with the Lightweight Dive System (LWDS) MK 3 Mod 0. Omission or negligent performance of prescribed maintenance procedures could result in equipment failure and injury or death to personnel. (page 6-1)**

**Before performing corrective maintenance on the LWDS, ensure that all pressure has been vented from the system. Accidental exposure to escaping high pressure air may result in injury or death to maintenance personnel. (page 6-2)**

**Accomplish procedures in a clean environment. Contamination of the breathing air system may result in diver injury or death. (pages 6-2 and 6-13)**

**Discard and replace all O-rings as standard procedure while performing maintenance. Failure of an O-ring in any component may cause further damage to equipment, mission abort, or diver injury or death. (page 6-2)**

**To avoid injury or death to personnel, never disassemble pilot valve while pressurized; adjust 1-2 turns. Load and unload pressures are  $145 \pm 5$  psi and  $165 \pm 5$  psi, respectively. Deviation from these pressure settings must have documented approval by supervisor before diving system. (page 6-7)**

**If in doubt about the serviceability of a part, repair or replace it immediately. Use only approved replacement parts. Failure of a component during a dive may result in diver injury or death. (pages 6-9 and 6-13)**

**Approved reentry control must be used for this procedure. (pages 6-27, 6-29, 6-31, 6-32, 6-34, 6-36, 6-42, 6-44, 6-46, 6-48, 6-50, 6-51, 6-53, 6-54, 6-57, 6-61, 6-64, 6-67, 6-68, 6-69, 6-70, 6-71, 6-73, 6-76, 6-77, 6-78, 6-80, 6-84, 6-87, and 6-88)**

**Exercise extreme care when handling pressure gauges. Failure to keep gauges, tools, and parts free of oil, grease, rust, or contaminants may cause damage or inaccurate readings. Failure to observe this warning may result in equipment failure and injury or death to personnel. (pages 6-36, 6-48, and 6-73)**

**Ensure gauge is securely installed. Failure to tighten gauge securely may result in damage to equipment and injury or death to personnel. (pages 6-38, 6-49, 6-74, and 6-90)**

## SS500-HK-MMO-010

**WARNINGS**

**Ensure pressure has been bled from HP air flasks before conducting corrective maintenance on the flasks. Failure to comply could result in injury or death to personnel. (page 6-46)**

**The PRIMARY and SECONDARY tags must remain affixed to the assigned PORT A, PORT B, and PORT C valve handles on the ASRA as the removal or swapping of tags can result in personnel injury or death. (page B-13)**

**Because the FADS III ASRA is capable of being pressurized to 5,000 psi, the ASRA must be connected only to volume tank and control console assemblies that have been modified for 5,000 psi service. Connection to an unmodified assembly can result in equipment damage and personnel injury or death. (page B-14)**

**Failure to connect hose assembly strain reliefs can cause personal injury or death should the hose separate or burst. (page B-15)**

**Ports A, B, and C on the ASRA must be depressurized whenever a port cap or hose is removed from a port connector. Removal of a port cap or hose when supply piping is pressurized can result in injury or death. (pages B-15 and B-36)**

**Fittings must be properly tightened and O-rings must be properly seated when connecting hoses. Fittings and O-rings that are not properly installed can allow HP air to escape and result in injury or death. Excessive tightening can damage threads. (page B-15)**

**3.0 CAUTIONS CONTAINED IN THIS MANUAL**

The following cautions appear in the text of this manual and are repeated here for emphasis.

**CAUTIONS**

**Do not join more than three 50-foot sections of diesel-compressor to volume tank hose (H-104) together as it may cause the system to function improperly. (pages 2-14 and A-5)**

**Use diesel fuel only. Ensure fuel tank vent is open. (pages 2-27, 2-41, 2-54, A-9, A-25, and A-37)**

**Fuel contamination can cause damage to the fuel injection system resulting in engine failure. (pages 2-27, 2-42, 2-54, A-9, A-25, and A-37)**

## SS500-HK-MMO-010

**CAUTIONS**

Never stop the diesel engine with the decompressors. Failure to comply with this caution may result in valve damage to engine. (pages 2-28, 2-29, 2-42, 2-53, 2-59, A-10, A-11, A-26, A-37, and A-43)

Components cleaned with NOC shall be rinsed thoroughly before the NOC has a chance to dry. Dry NOC deposits are extremely difficult to remove. (page 4-7)

Do not use metal screwdrivers or metal picks to remove O-rings. To avoid damage to O-ring groove, whenever possible remove O-rings using fingers only. (page 4-7)

To avoid damage to valves, valve clearances must be maintained correctly. (page 6-5)

Tighten fittings carefully to avoid damage to aluminum unloader assembly. (page 6-28)

To prevent damage to compressor, ensure sensing lines are positioned correctly. (page 6-28)

Do not allow water or debris to enter the oil fill pipe during performance of this procedure. (page 6-28)

Do not overtighten bolts. If plastic deforms or gasket extrudes, bolts are too tight and seal must be replaced. (page 6-29)

**Do not remove snubber from this gauge.** Failure to comply will result in damage to the gauge. (page 6-37)

Do not let stem rotate in the gauge. Failure to comply will result in damage to the gauge. (page 6-38)

Handle flask racks and flasks carefully to avoid damage to equipment during removal/installation. (pages 6-39 and 6-41)

Do not repair flasks that have been damaged beyond inspection criteria stated in Table D-1. (page 6-39)

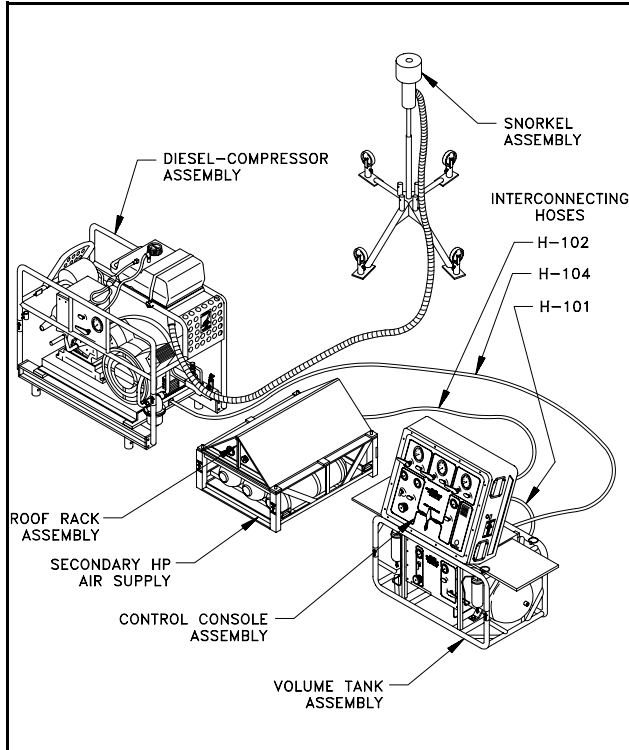
Ensure new relief valve is tagged showing  $275 \pm 5$  psi relief pressure. (pages 6-71 and 6-87)

Tighten hose fittings and port caps to proper torque as excessive tightening can damage threads. (page B-36)

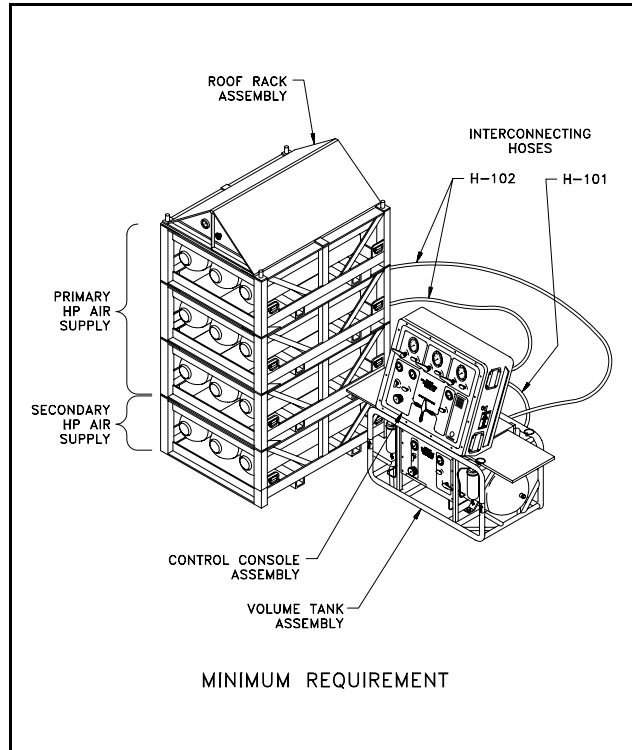
THIS PAGE INTENTIONALLY LEFT BLANK



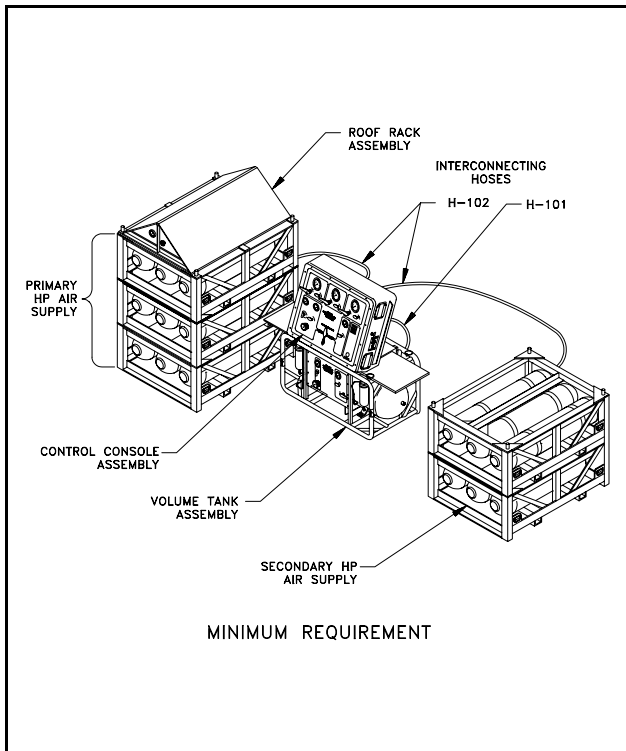
SS500-HK-MMO-010



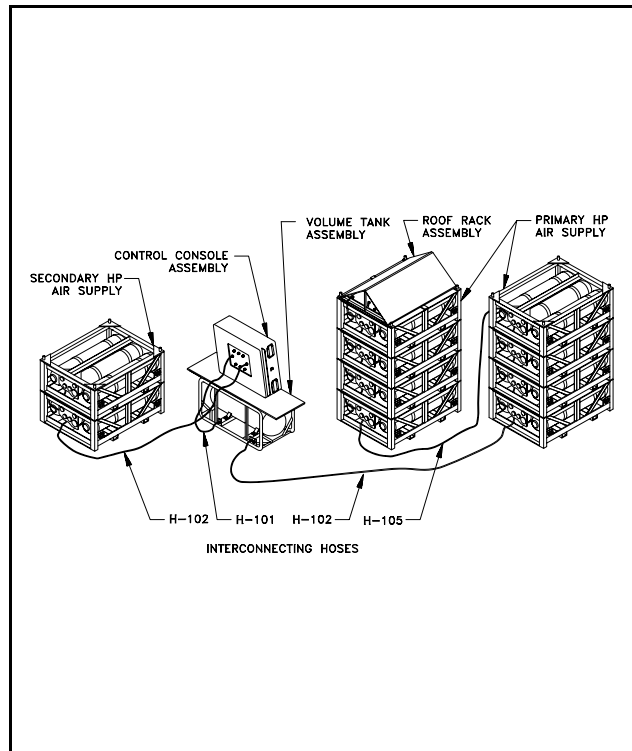
Configuration 1



Configuration 2



Configuration 3



Multiple Stacks, Configuration 3

Figure 1-1. Overview of the Lightweight Dive System (LWDS) MK 3 Mod 0

SS500-HK-MMO-010

## CHAPTER 1

### GENERAL INFORMATION AND SAFETY PRECAUTIONS

#### 1.1 SAFETY PRECAUTIONS

Personnel using the Lightweight Dive System (LWDS) MK 3 Mod 0 shall observe the safety precautions and procedures specified in this technical manual. Personnel must be thoroughly familiar with all safety practices and understand the potential hazards associated with the LWDS before using the system or performing maintenance on the equipment. Personnel must also understand and comply with the standard safety precautions and guidelines provided in the Safety Summary of this manual.

Specific warnings, cautions, and notes are provided in this manual to highlight critical operations or procedures that present potential hazards to personnel or that may result in damage to the equipment. The following notations define warnings, cautions, and notes as used in the text.

#### **WARNING**

**An operating or maintenance procedure, practice, condition, or statement, which if not strictly observed could result in injury to or death of personnel.**

#### **CAUTION**

An operating or maintenance procedure, practice, condition, or statement, which if not strictly observed could result in damage to or destruction of equipment, loss of mission effectiveness, or long-term health hazards to personnel.

#### **NOTE**

An essential operating or maintenance procedure, practice, condition, or statement that must be highlighted.

#### 1.2 INTRODUCTION

The LWDS MK 3 Mod 0 (Figure 1-1) and LWDS MK 3 Mod 1 (Appendix B, Figure B-1) are portable, self-contained, surface-supplied dive systems. This manual contains detailed operation and maintenance information relevant to the LWDS MK 3 Mod 0 and also serves as a

## SS500-HK-MMO-010

basic reference manual for the Mod 1 components that are common to both systems. Information unique to the LWDS MK 3 Mod 1 can be found in Appendix B.

The LWDS MK 3 Mod 0, which may be deployed from dockside or from a variety of support platforms, can be set up and operated in one of three separate configurations. The system provides sufficient air for two working divers (and one standby diver) operating at a moderately heavy work rate to a maximum depth of 60 feet of seawater (fsw) with Configuration 1, 130 fsw with Configuration 2, and 190 fsw with Configuration 3.

The LWDS MK 3 Mod 1 has only one configuration and is used for dive missions limited to a maximum depth of 190 fsw. The LWDS MK 3 Mod 1 uses modified control console and volume tank assemblies that permit the use of 5,000 pounds per square inch (psi) primary and secondary air supplies. For more information, refer to Appendix B.

### **1.3 PHYSICAL ARRANGEMENT**

The LWDS MK 3 Mod 0 is set up using one of three equipment configurations. The configuration used is determined by the maximum depth limit of the dive mission and the amount of air required to complete the dive. Major assemblies within each configuration are joined by interconnecting hose assemblies.

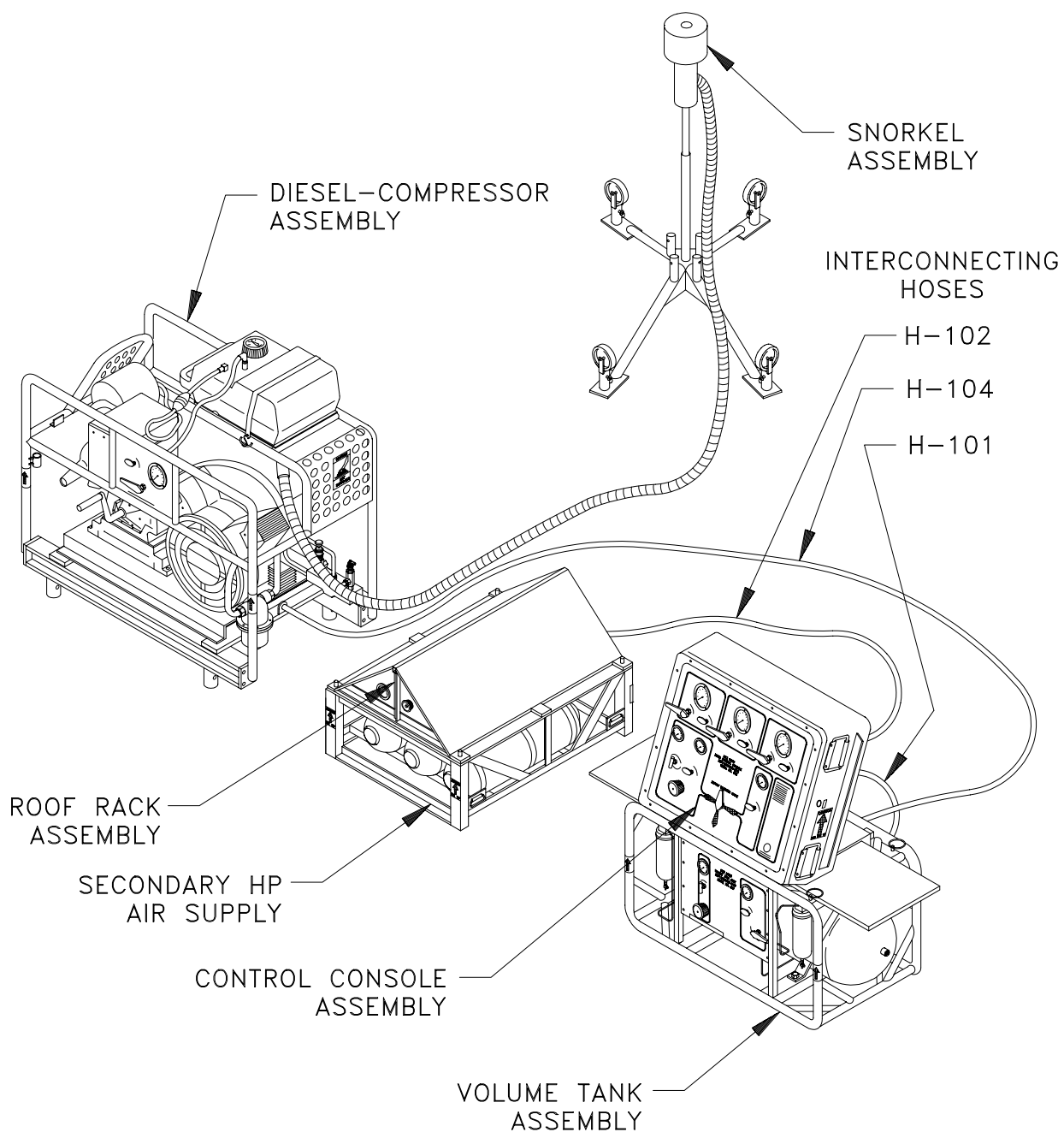
**1.3.1 CONFIGURATION 1.** Configuration 1 (Figure 1-2) is used for dive missions limited to a maximum dive depth of 60 fsw. The primary air supply consists of a frame-mounted diesel-compressor assembly that produces low pressure (LP) air. Fresh, filtered air is supplied to the compressor intake through a remote snorkel assembly. The LP air flows from the diesel-compressor assembly to the volume tank assembly where the air is stored and filtered a second time before being passed through the control console assembly to the divers.

Secondary air is provided by a single high pressure (HP) flask rack assembly containing three HP composite flasks and topped by a roof rack assembly. The secondary HP air flows to the control console assembly where it is reduced to LP air through an HP regulator and provided to the divers.

**1.3.2 CONFIGURATION 2.** Configuration 2 (Figure 1-3) is used for dive missions limited to a maximum dive depth of 130 fsw. The primary HP air supply consists of a minimum of three vertically stacked flask rack assemblies, each containing three HP composite flasks. The flask rack assemblies are interconnected and cascaded, which enables a single pressure reading to be taken from the roof rack assembly located on top. The roof rack assembly enables the flasks to be charged before, during, or after a mission. The HP air flows to the volume tank assembly where it is reduced to LP air through an HP regulator. The LP air is then stored in the volume tank assembly where it is filtered before passing to the control console assembly.

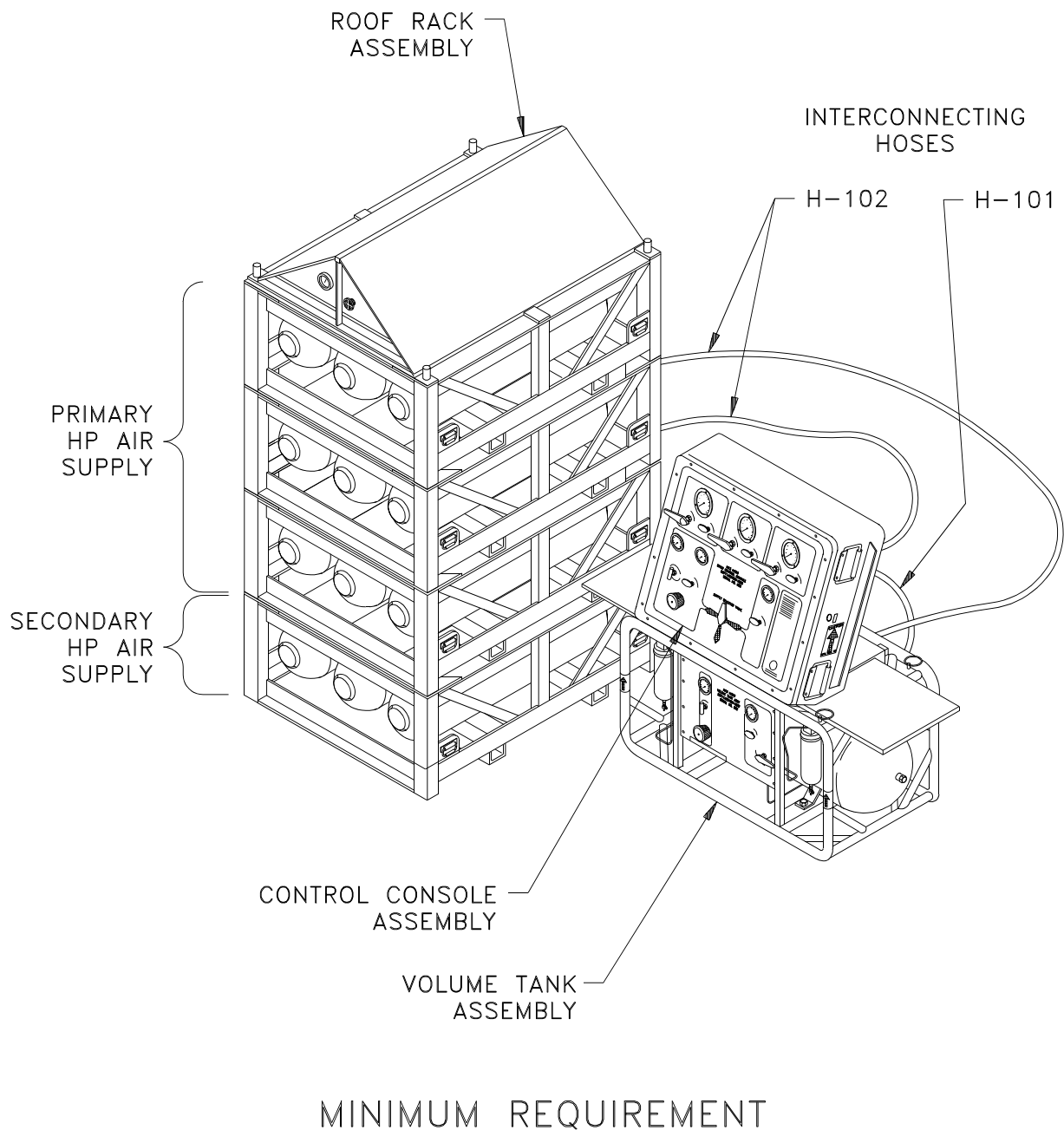
The secondary HP air supply is similar to that in Configuration 1, except for the placement of the flask rack assembly and the roof rack assembly. In Configuration 2, the secondary HP air flask rack assembly is normally placed at the bottom of the stack of primary HP air flask rack assemblies, and the roof rack assembly is placed at the top of the stack.

### SS500-HK-MMO-010



**Figure 1-2. Lightweight Dive System (LWDS) MK 3 Mod 0, Configuration 1**

### SS500-HK-MMO-010



**Figure 1-3. Lightweight Dive System (LWDS) MK 3 Mod 0, Configuration 2**

## SS500-HK-MMO-010

**1.3.3 CONFIGURATION 3.** Configuration 3 (Figure 1-4) is used for dive missions limited to a maximum dive depth of 190 fsw. The primary HP air supply consists of a minimum of three vertically stacked flask rack assemblies, each containing three HP composite flasks. A maximum of four flask rack assemblies may be placed in one stack. If more than four flask rack assemblies are required for the dive mission, a second stack of flask rack assemblies may be added (Figure 1-5). The stacks are interconnected and the roof rack assembly is placed on the last stack of flask rack assemblies. The flask rack assemblies within each stack are interconnected and cascaded, which enables a single pressure reading to be taken from the roof rack assembly. The roof rack assembly enables the flasks to be charged before, during, or after a mission. The HP air flows to the volume tank assembly where it is reduced to LP air through an HP regulator. The LP air is then stored in the volume tank assembly where it is filtered before passing to the control console assembly.

The secondary HP air supply consists of a minimum of two vertically stacked flask rack assemblies, each containing three HP composite flasks. The secondary flask rack assemblies are interconnected and cascaded, which enables a single pressure reading to be taken at the control console assembly. The HP air is reduced to LP air through an HP regulator on the control console assembly, and the LP air is then provided to the divers.

## 1.4 SYSTEM EQUIPMENT

The LWDS MK 3 Mod 0 includes the major hardware assemblies and subassemblies listed below. Functional flow diagrams showing the interrelationship of these major assemblies and subassemblies within each configuration are provided in Chapter 3, Figures 3-1 through 3-4.

### Major Assemblies

- Diesel-Compressor Assembly
- Primary HP Air Supply
- Volume Tank Assembly
- Control Console Assembly
- Secondary HP Air Supply

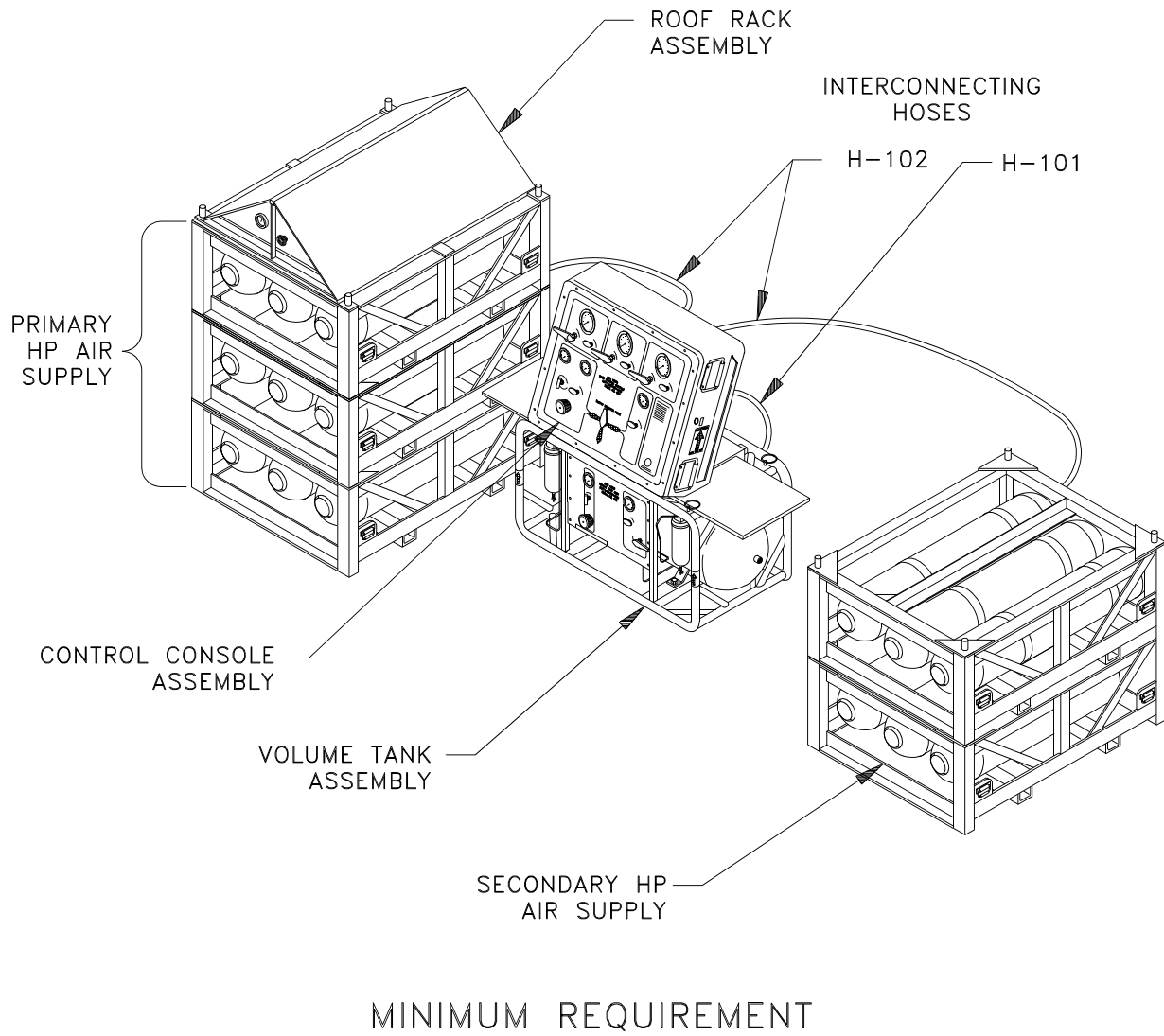
### Major Subassemblies

- Roof Rack Assembly
- Interconnecting Hose Assemblies

**1.4.1 DIESEL-COMPRESSOR ASSEMBLY.** The diesel-compressor assembly consists of an air compressor belt-driven by a diesel engine. The compressor can deliver 18.6 standard cubic feet per minute (scfm) of air at 175 pounds per square inch gauge (psig). The unit is mounted on a rigid, portable frame that is equipped with a set of removable wheels to permit easy positioning at the operating site. The function of the diesel-compressor assembly is to provide primary LP air in Configuration 1.

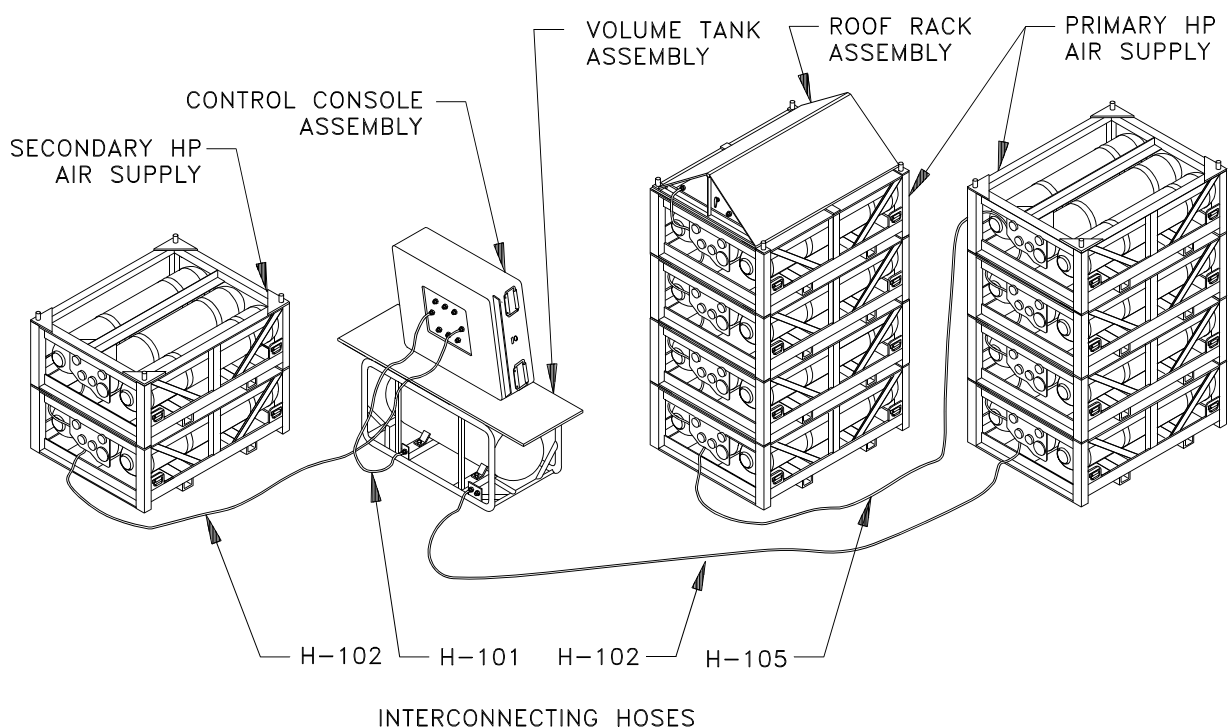
The snorkel assembly supplies particle-free air to the compressor intake. The assembly consists of a flexible hose, an intake assembly containing an air filter system, and a telescoping frame. The frame allows the assembly to be positioned up to 20 feet from the diesel-compressor assembly.

# SS500-HK-MMO-010



**Figure 1-4. Lightweight Dive System (LWDS) MK 3 Mod 0, Configuration 3**

## SS500-HK-MMO-010



**Figure 1-5. Multiple Stacks of Flask Racks, Configuration 3**

**1.4.2 PRIMARY HP AIR SUPPLY.** The primary HP air supply consists of a minimum of three vertically stacked flask rack assemblies, each containing three interconnected composite flasks. Each flask contains 191 standard cubic feet (scf) of air at 3,000 psig. The flask rack assemblies are interconnected and cascaded, which enables a single pressure reading to be taken from the roof rack assembly and also enables the flasks to be charged before, during, or after a mission. Additional flask rack assemblies may be added as required, but each stack of flask rack assemblies shall not exceed four high. If multiple stacks are used, the stacks are interconnected by hose assemblies and the roof rack assembly is placed on the last stack (Figure 1-5).

**1.4.3 VOLUME TANK ASSEMBLY.** The volume tank is a two-man portable, frame-mounted unit with a 30-gallon floodable volume. LP air is supplied to the volume tank by either the diesel-compressor assembly (Configuration 1) or by primary HP air (Configurations 2 and 3) that has been reduced to LP air by a regulator to a maximum working pressure of 250 psig. An air filtration system prevents contamination of diver air. The volume tank connects to the control console assembly via an interconnecting hose assembly. When used with the diesel-compressor assembly in Configuration 1, the volume tank dampens air pulsation to supply diver air at a constant rate.



## SS500-HK-MMO-010

**1.4.4 CONTROL CONSOLE ASSEMBLY.** The control console assembly contains piping and controls for the primary LP air supply (Configuration 1 only) and the secondary HP air supply (all three configurations) to provide a maximum working pressure of 250 psig. The primary HP air supply (Configurations 2 and 3) is reduced to LP air at the volume tank prior to delivery to the control console assembly. HP air from the secondary air supply flows directly to the control console assembly and is then reduced to LP air through an HP regulator on the console. The control console assembly distributes the LP air to three diving hose connections for breathing and to three pneumofathometer connections for monitoring diver depth.

**1.4.5 SECONDARY HP AIR SUPPLY.** Secondary HP air is available with all three system configurations and is supplied from one or more flask rack assemblies, depending on the configuration used. Each rack contains three composite air flasks identical to the primary HP flasks. The flasks are connected directly to HP inlet fittings on the control console assembly, where the pressure is reduced through an HP regulator. In Configuration 2, the secondary HP air supply may be located at the bottom of the primary HP air supply, making a total of four vertically stacked racks with the roof rack assembly on top. In Configuration 3, a separate stack containing a minimum of two secondary flask rack assemblies is required.

**1.4.6 ROOF RACK ASSEMBLY.** One roof rack assembly is supplied with each system. In Configuration 1, the roof rack assembly is placed on top of the secondary HP flask rack assembly. In Configurations 2 and 3, the roof rack assembly is placed on top of a maximum of four vertically stacked flask rack assemblies. The flask racks are interconnected and cascaded to enable a single pressure reading to be taken from the roof rack assembly and also to enable charging of the flasks before, during, or after a mission.

**1.4.7 INTERCONNECTING HOSE ASSEMBLIES.** Air is transferred between major LWDS MK 3 Mod 0 assemblies and is cascaded in the HP air supplies by way of interconnecting hose assemblies. All interconnecting hose assemblies, except for the flask rack interconnecting hose assemblies, incorporate a 3/16-inch outside diameter, coated, stainless steel cable for strain relief. The interconnecting hose assemblies for the LWDS MK 3 Mod 0 consist of the following (refer to Chapter 3 for detailed descriptions):

- **H-101—Volume Tank to Control Console Hose Assembly.** Used in all configurations to connect the volume tank assembly to the control console assembly. Consists of a 10-foot length of 1/2-inch inside diameter (ID) rubber diver hose with fittings that are sized to prevent accidental connection to the diesel-compressor assembly.
- **H-102—Primary HP Air to Volume Tank Hose Assembly.** Used in Configurations 2 and 3 to connect a single stack of primary flask rack assemblies to the volume tank assembly. Multiple stacks are interconnected with H-105 and the lowest in-line stack is connected to the volume tank assembly with H-102. Consists of a 30-foot length of 3/8-inch ID thermoplastic hose with fittings.
- **H-102—Secondary HP Air to Control Console Hose Assembly.** Used in all configurations to connect a single stack of secondary flask rack assemblies to the control console assembly. Consists of a 30-foot length of 3/8-inch ID thermoplastic hose with fittings.

## SS500-HK-MMO-010

- H-104—Diesel-Compressor to Volume Tank Hose Assembly. Used only in Configuration 1 to connect the diesel-compressor assembly to the volume tank assembly. Each hose assembly consists of a 50-foot length of 1/2-inch ID rubber diver hose with fittings that are sized to prevent accidental connection to the control console assembly. Three H-104 hose assemblies are supplied with the system and may be combined as required up to a total length of 150 feet.
- H-105—Primary HP Air to Primary HP Air Hose Assembly. Used in Configurations 2 and 3 to interconnect multiple stacks of primary flask rack assemblies. Assemblies consist of fittings and user-defined lengths of 3/8-inch ID thermoplastic hoses.
- Flask Rack Interconnecting Hose Assemblies. Used in all configurations in both the primary and secondary flask rack assemblies. Four hose assemblies (or flask whips) are supplied with each rack—three are used to connect the three flasks in each rack with the rack manifold and the other is used to connect the rack manifold with an adjoining rack, or if uppermost rack, with the roof rack assembly. Assemblies consist of fittings and 24-inch long, 1/4-inch ID stainless steel overbraided Teflon® hoses.

## 1.5 REFERENCE DATA

Table 1-1 summarizes the physical characteristics of the LWDS MK 3 Mod 0. Table 1-2 provides a list of the equipment, accessories, and documents supplied with the LWDS MK 3 Mod 0. Documents that are referenced in this manual but are not supplied with the system are listed in Table 1-3.

**Table 1-1. LWDS MK 3 Mod 0 Physical Characteristics**

Assembly	Dimensions (Shipping) H×W×L (in.)	Weight (lb)	Capacity
Control Console Assembly	17 × 31 × 33	150	LP - 250 psig HP - 3,000 psig
Diesel-Compressor Assembly	40 × 48 × 66	650	18.6 scfm @ 175 psig
Flask Rack Assembly (Primary/Secondary HP Air Supplies)	24 × 40 × 46	200	573 scf @ 3,000 psig
Roof Rack Assembly	11 × 40 × 46	50	3,000 psig
Volume Tank Assembly	46 × 29 × 28	250	30 gallons (4 cubic feet) LP - 250 psig HP - 3,000 psig

## SS500-HK-MMO-010

**Table 1-2. Equipment, Accessories, and Documents Supplied**

<b>Nomenclature</b>	<b>Part Number</b>
Ancillary Equipment: Shipping Container	53711-6314717
Tool Kit, consisting of:	53711-6314450
• Hand tachometer	53711-6314451
• Packing adjustment tool	53711-6314453
• Scuba charging adapter	53711-6314452
Control Console Assembly	53711-6314590
Diesel-Compressor Assembly	53711-6314342
Documentation: Atlas Copco Parts List for L-Series Blocks (Compressor)	1310-9050-57
Lightweight Dive System (LWDS) MK 3 Mod 0 Technical Manual	SS500-HK-MMO-010
Lister Petter LT, LV Operators Handbook (Diesel Engine)	027-08186
Lister Petter LT1, LV1 & 2 Parts List (Diesel Engine)	027-08060
Flask Rack Assembly (Primary/Secondary HP Air Supplies), containing:	53711-6314552
Composite Flasks, Kevlar®	53711-6314579
Composite Flasks, Carbon Fiber	53711-3614585
Flask Rack Interconnecting Hose Assemblies	53711-6314568
Interconnecting Hose Assemblies:	
H-101—Volume Tank to Control Console	53711-6314712
H-102—Primary HP Air to Volume Tank	53711-6314700
H-102—Secondary HP Air to Control Console	53711-6314700
H-104—Diesel-Compressor to Volume Tank	53711-6314713
H-105—Primary HP Air to Primary HP Air	53711-6314703
Roof Rack Assembly	53711-6314565
Snorkel Assembly	53711-6314347
Volume Tank Assembly	53711-6314500

**Table 1-3. Referenced Documents**

<b>Document Name</b>	<b>Identifying Number or Web Address</b>
Allowance Parts List (APL), LWDS MK 3 Mod 0	990010127
Cleaning Diving System Air Components with NOC	NAVSEA-00C4-PI-002 1. Go to: <a href="http://www.supsalv.org">http://www.supsalv.org</a> 2. Place cursor on <u>00C4 Certification</u> 3. Click on <u>Certification Publications</u> 4. Go to <u>Process Instructions</u> 5. Click on <u>Cleaning Diving System Air Components with NOC</u>
Cleaning of Shipboard Compressed Air Systems	MIL-STD-1622

## SS500-HK-MMO-010

Table 1-3. Referenced Documents—Continued

Document Name	Identifying Number or Web Address
Composite Flask Exemptions from U.S. Department of Transportation (DOT)	See Appendix F for detailed list
Continuation of Certification Handbook for U.S. Navy Diving Systems	NAVSEA SS521-AB-HBK-010 1. Go to: <a href="http://www.supsalv.org">http://www.supsalv.org</a> 2. Place cursor on <i>00C4 Certification</i> 3. Click on <i>Certification Publications</i> 4. Click on <i>Continuation of Certification Handbook</i>
Diver Life Support System Cleaning	1. Go to: <a href="http://www.supsalv.org">http://www.supsalv.org</a> 2. Place cursor on <i>00C4 Certification</i> 3. Click on <i>Certification Publications</i> 4. Go to <i>Topside Tech Notes</i> 5. Click on <i>Volume VI: Component Cleaning</i>
Diving Equipment Authorized for U.S. Navy Use (ANU)	1. Go to: <a href="http://www.supsalv.org">http://www.supsalv.org</a> 2. Place cursor on <i>00C3 Diving</i> 3. Click on <i>ANU List</i> 4. Click on <i>View the Diving Equipment ANU</i>
Failure Analysis Report (FAR)	NAVSEA Form 10560/4 (see Figure 2-18) Also available on-line as follows: 1. Go to: <a href="http://www.supsalv.org">http://www.supsalv.org</a> 2. Place cursor on <i>00C3 Diving</i> 3. Place cursor on <i>Diver Support Menu</i> 4. Click on <i>Failure Analysis Report</i> 5. Enter password
Fly Away Dive System (FADS) III Air System Operation and Maintenance Manual	NAVSEA S9592-B1-MMO-010
Guidelines for Visual Inspection and Requalification of Fiber Reinforced High Pressure Cylinders	Compressed Gas Association C-6.2
Hydrostatic Testing Facilities (by identification number or state listing)	<a href="http://hazmat.dot.gov/files/approvals/hydro/hydro_retesters.htm">http://hazmat.dot.gov/files/approvals/hydro/hydro_retesters.htm</a>
Methods for Hydrostatic Testing of Compressed Gas Cylinders	Compressed Gas Association C-1
Navy Occupational Safety and Health (NAVOSH) Program Manual for Forces Afloat	OPNAVINST 5100.19 Series
Navy Occupational Safety and Health Program Manual	OPNAVINST 5100.23 Series
Planned Maintenance System (PMS) for: Diesel Engine (Lister Model LV2) / Compressor (Atlas Copco Model LT8) Diver's Compressed HP Air Flasks, Cylinders, Separators, Filters, Piping, Valves, Gages	MIP Control No. 5921/170 MIP Control No. 5921/171
PMS Feedback Report	OPNAV 4790/7B

SS500-HK-MMO-010

**Table 1-3. Referenced Documents—Continued**

<b>Document Name</b>	<b>Identifying Number or Web Address</b>
Precision Cleaning and Testing of Shipboard Oxygen, Helium, Helium-Oxygen, and Nitrogen Systems	MIL-STD-1330
Re-Entry Control Information and Forms	<ol style="list-style-type: none"> <li>1. Go to: <a href="http://www.supsalv.org">http://www.supsalv.org</a></li> <li>2. Place cursor on <u>00C4 Certification</u></li> <li>3. Click on <u>Certification Publications</u></li> <li>4. Click on <u>Standardized Diver Re-Entry Control (REC) Procedures</u></li> </ol>
Ships' Maintenance Material Management (3-M) Manual	OPNAVINST 4790.4 Series
Specifications for Construction Lightweight Dive System FY 89	NAVSEA T9592-AB-SPN-010
Standardized Diver Re-Entry Control (REC) Procedures	<ol style="list-style-type: none"> <li>1. Go to: <a href="http://www.supsalv.org">http://www.supsalv.org</a></li> <li>2. Place cursor on <u>00C4 Certification</u></li> <li>3. Click on <u>Certification Publications</u></li> <li>4. Click on <u>Standardized Diver Re-Entry Control (REC) Procedures</u></li> </ol>
Transportable Recompression Chamber System (TRCS) MK 6 Mod 0/Mod 1 Operation and Maintenance Manual	SS500-AW-MMM-010
U.S. Navy Diving and Manned Hyperbaric Systems Safety Certification Manual	NAVSEA SS521-AA-MAN-010 (Listed but not available on-line)
U.S. Navy Diving Manual	NAVSEA SS521-AG-PRO-010 <ol style="list-style-type: none"> <li>1. Go to: <a href="http://www.supsalv.org">http://www.supsalv.org</a></li> <li>2. Place cursor on <u>00C3 Diving</u></li> <li>3. Click on <u>Diving Publications</u></li> <li>4. Choose desired method of accessing <i>US Navy Diving Manual</i></li> </ol>

**NOTE**

Since the SEA 00C website and other websites listed in Table 1-3 are constantly being updated, the directions in Table 1-3 for accessing the various publications may quickly become obsolete. If necessary, browse the site using the directions as general guidelines to locate the document.

SS500-HK-MMO-010

## CHAPTER 2

### OPERATION

#### 2.1 INTRODUCTION

The Lightweight Dive System (LWDS) MK 3 Mod 0 is a portable, self-contained, surface-supplied dive system that can be arranged in one of three different configurations and may be deployed from dockside or a wide variety of support platforms. The LWDS provides breathing air to two working divers (and one standby diver) operating at a moderately heavy work rate to a maximum depth of 60 feet of seawater (fsw) with Configuration 1, 130 fsw with Configuration 2, and 190 fsw with Configuration 3.

Chapter 2 provides a description of the LWDS controls and indicators, and outlines operating procedures for use with all three configurations. Procedures are presented in the sequence of a normal dive operation, starting with premission equipment checks through postmission checks. A summary of emergency operating procedures follows the postmission procedures table. Detailed dive operations and decompression procedures are not covered in this manual but may be found in the *U.S. Navy Diving Manual*, NAVSEA SS521-AG-PRO-010. Information covered in this chapter is presented as follows:

- a. Para. 2.2—Preoperational Conditions and Setup . . . . . Page 2-1
- b. Para. 2.3—Operating Procedures . . . . . Page 2-12
- c. Para. 2.4—Emergency Procedure . . . . . Page 2-65
- d. Para. 2.5—Failure Analysis Reporting . . . . . Page 2-65
- e. Para. 2.6—Accident/Incident Equipment Status Reporting . . . . . Page 2-66

#### WARNING

**Divers and support personnel shall perform the operating procedures presented in this manual when using the LWDS. Failure to perform prescribed procedures may result in equipment failure and personnel injury or death.**

#### 2.2 PREOPERATIONAL CONDITIONS AND SETUP

Prior to deploying the LWDS to perform a mission, all dive and support personnel must be thoroughly familiar with its operational capabilities and procedures. Tables 2-1 and 2-2 provide equipment checklists of the components, hoses, and adapters required to successfully operate the LWDS. Tables 2-3 through 2-6 identify the controls and indicators for each major assembly. Before operating the LWDS, perform the appropriate Planned Maintenance System (PMS) Maintenance Requirement Cards (MRCs) in accordance with the Maintenance Index Pages (MIPs) for the LWDS MK 3 Mod 0 (refer to Chapter 4 for more information).

**2.2.1 EQUIPMENT CHECKLIST.** Tables 2-1 and 2-2 contain descriptive checklists of the components, hoses, and adapters that are required to perform operations using the LWDS in

## SS500-HK-MMO-010

each of its configurations. Prior to deployment, ensure the items listed in Tables 2-1 and 2-2 are serviced and available in accordance with the selected configuration.

**Table 2-1. LWDS MK 3 Mod 0 Equipment Checklist - Configuration 1**

Item	Component/Description	Qty.
1	Diesel-Compressor Assembly	1
2	Snorkel Assembly	1
3	Volume Tank Assembly (30-gallon capacity)	1
4	Control Console Assembly	1
5	High Pressure (HP) Flask Rack Assembly	1
6	Roof Rack Assembly	1
7	Low Pressure (LP) Deck Hose (H-101), 10-ft section, 1/2-in. inside diameter (ID) (37° flare fittings with 3/4-16 thread)	1
8	HP Deck Hose (H-102), 30-ft section, 3/8-in. ID (37° flare fittings with 9/16-18 thread)	1
9	LP Deck Hose (H-104), 50-ft section, 1/2-in. ID (37° flare fittings with 7/8-14 thread)	3
10	37° Flare to 37° Flare Union (37° male 7/8-14 both ends) (AN 815-10K fittings)	2
11	20-ft Extension Hose for Compressor Intake to Snorkel Assembly	1
12	LWDS Shipping Container	1
13	Documentation: Atlas Copco Parts List for L-Series Blocks (Compressor) Lister Petter LT, LV Operators Handbook (Diesel Engine) Lister Petter LT1, LV1 & 2 Parts List (Diesel Engine)	1 1 1

**Table 2-2. LWDS MK 3 Mod 0 Equipment Checklist - Configurations 2 and 3**

Item	Component/Description	Qty.
1	Volume Tank Assembly (30-gallon capacity)	1
2	Control Console Assembly	1
3	HP Flask Rack Assembly* Configuration 2 Configuration 3	4 minimum 5 minimum
4	Roof Rack Assembly	1
5	LP Deck Hose (H-101), 10-ft section, 1/2-in. ID (37° flare fittings with 3/4-16 thread)	1
6	HP Deck Hose (H-102), 30-ft section, 3/8-in. ID (37° flare fittings with 9/16-18 thread)	2
7	LWDS Shipping Container	1

\* When multiple stacks of flask rack assemblies are required, ensure a sufficient number of racks are available. Also ensure HP deck hose (H-105) is available for interconnecting the stacks.

## SS500-HK-MMO-010

**2.2.2 INITIAL CONTROL AND INDICATOR SETTINGS.** Tables 2-3 through 2-6 identify the controls and indicators for the LWDS MK 3 Mod 0. The first column of each table contains index numbers that correspond to the callouts shown in Figures 2-1 through 2-7 (as indicated). Additional columns contain the panel labels shown on the equipment, Joint Identification Drawing (JID) numbers, and a brief description of each component's function. Prior to conducting operations, ensure all valves are turned fully clockwise in the closed or unloaded position. Turn HP regulators fully counterclockwise to close. Ensure all pressure indicators read zero, and all levers and handles are in the OFF or disengaged position.

**NOTE**

The following is a key to the Joint Identification Drawing (JID) numbers used in this manual for the LWDS MK 3 Mod 0 valves and gauges:

ALP = Air Low Pressure	200's = Volume Tank Assembly
AHP = Air High Pressure	300's = Control Console Assembly
V = Valve	400's = Diesel-Compressor Assembly
G = Gauge	500's = Flask Rack Assemblies
	600's = Roof Rack Assembly

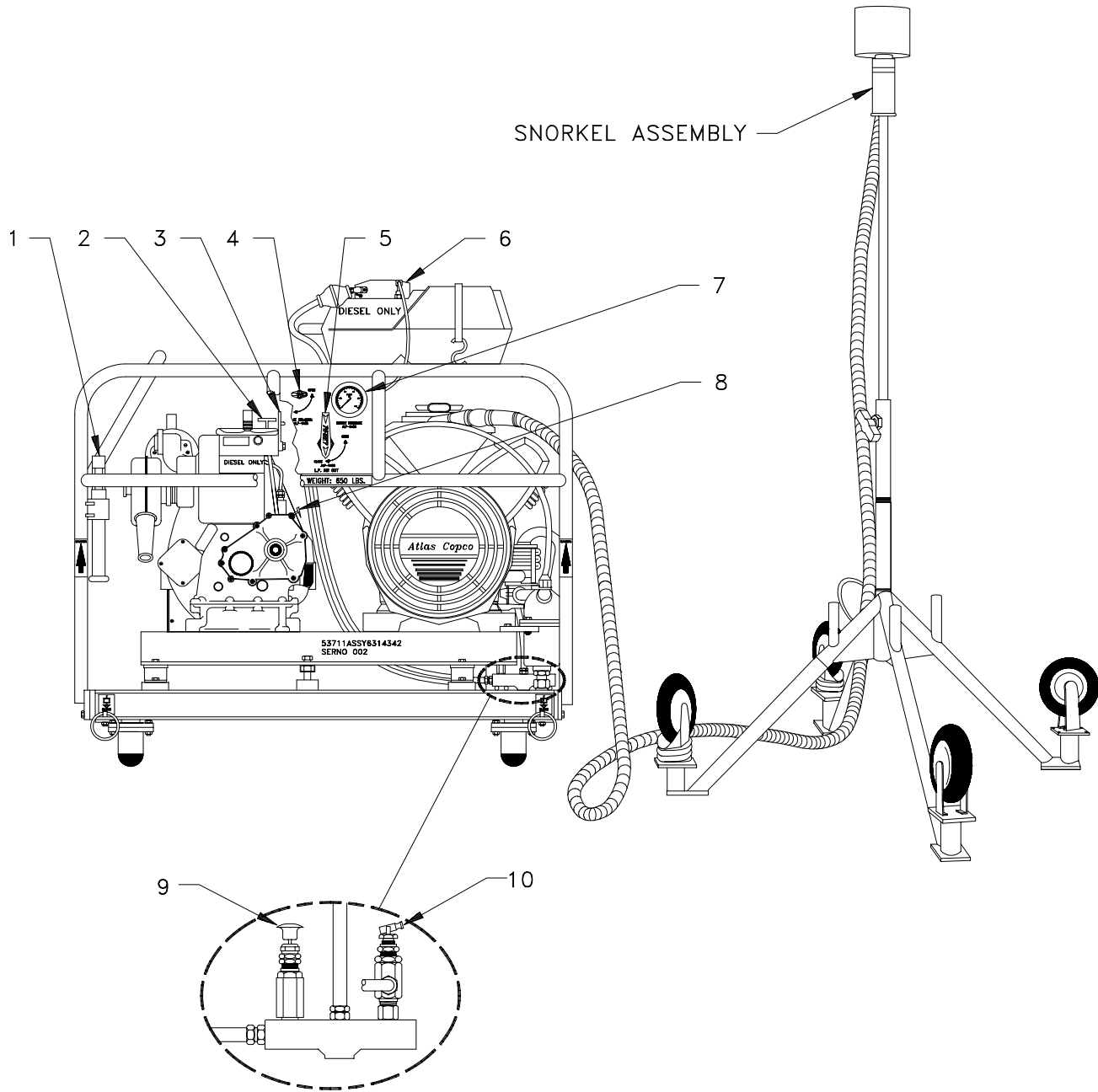
Example: Using the above key, ALP-V405 would be an Air Low Pressure Valve found in the Diesel-Compressor Assembly.

**Table 2-3. Diesel-Compressor Assembly Controls and Indicators**  
(Refer to Figures 2-1 and 2-2)

Index No.	Panel Label	JID No.	Function
1	N/A	N/A	Starter Handle
2	N/A	N/A	Stop/Run Cable
3	N/A	N/A	Engine Decompressor Lever
4	GAUGE ISOLATION	ALP-V405	Compressor Gauge Isolation Valve
5	L.P. AIR OUT	ALP-V401	Compressor Outlet Supply Valve
6	N/A	N/A	Fuel Gauge
7	SUPPLY PRESSURE	ALP-G406	Compressor LP Pressure Gauge (0-300 psi)
8	N/A	N/A	Engine Oil Level Indicator
9	N/A	ALP-V404	Relief Valve
10	N/A	ALP-V403	Pilot Valve
11	N/A	N/A	Compressor Oil Level Gauge
12	N/A	ALP-V402	Moisture Separator Drain Valve



# SS500-HK-MMO-010



Shows view as seen from front of assembly--  
manifold located at rear of assembly

**Figure 2-1. Diesel-Compressor Assembly with Snorkel Assembly**

SS500-HK-MMO-010

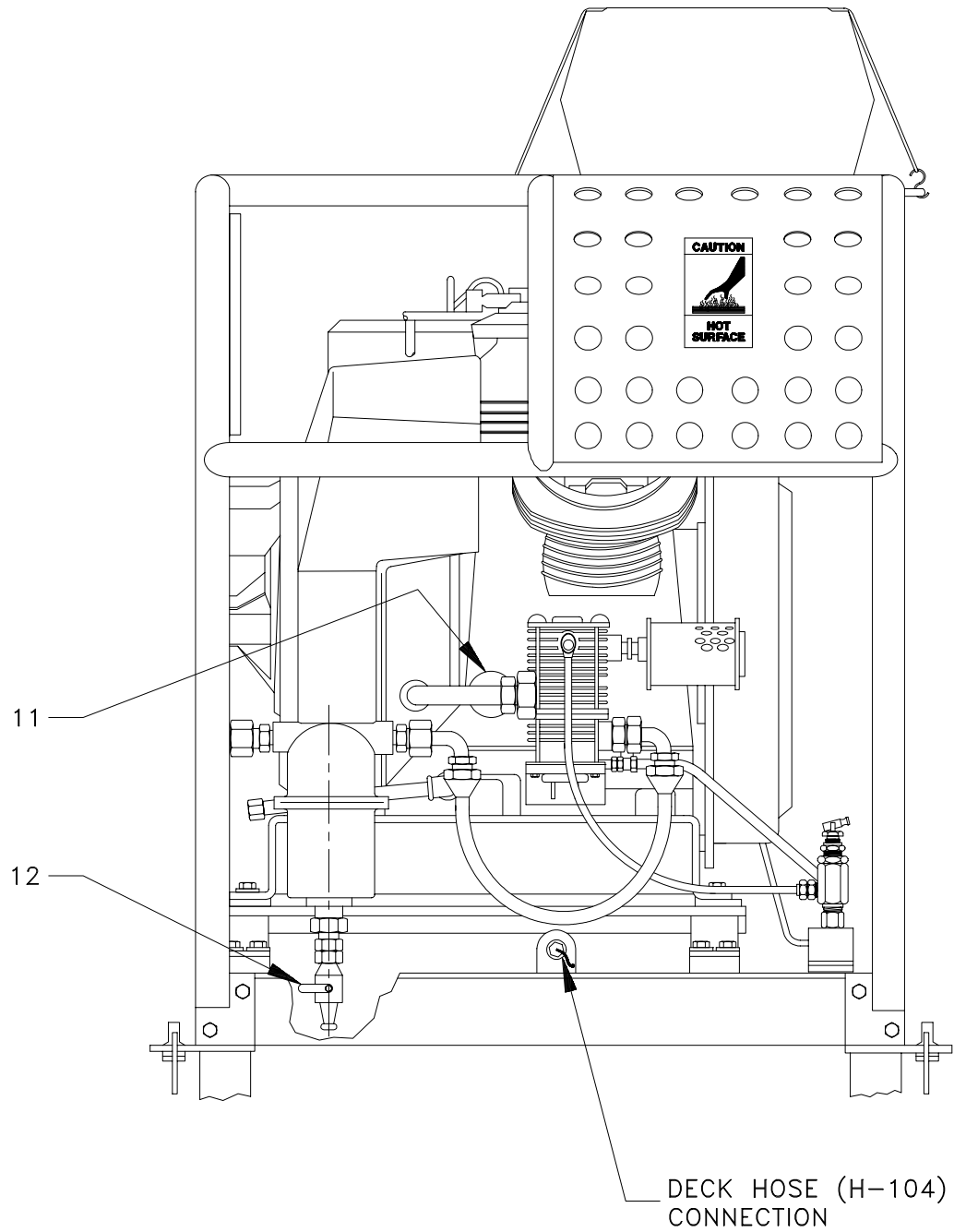
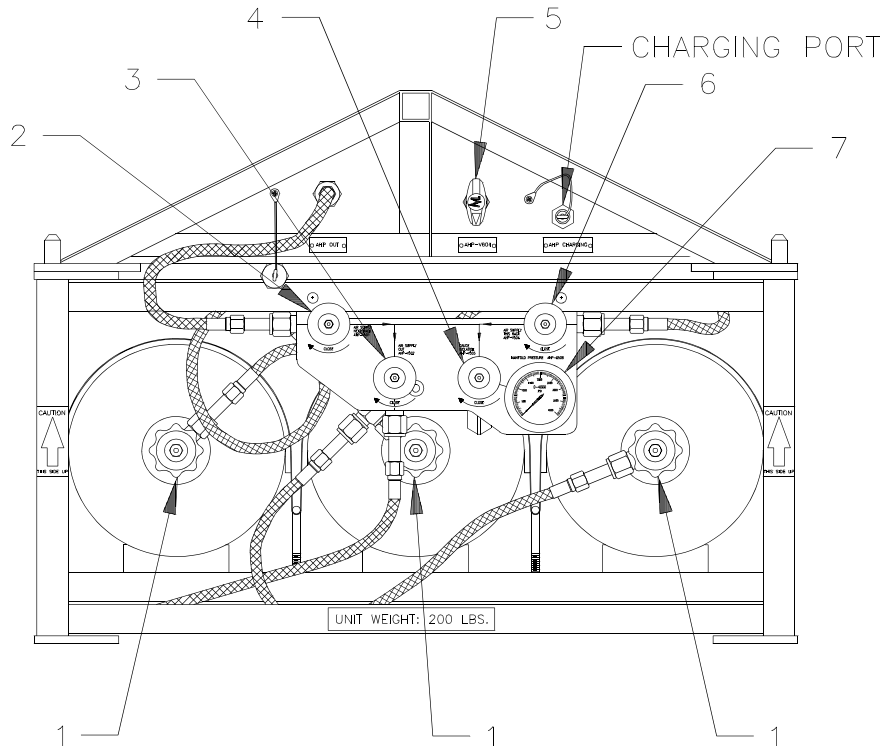


Figure 2-2. Diesel-Compressor Assembly (Right Side View)

## SS500-HK-MMO-010

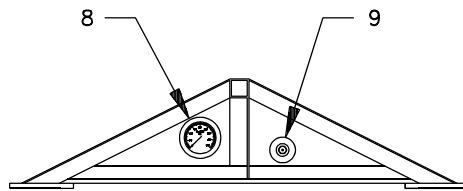
**Table 2-4. Primary and Secondary HP Air Supply Controls and Indicators**  
(Refer to Figures 2-3, 2-4, and 2-5)

Index No.	Panel Label	JID No.	Function
1	N/A N/A N/A	AHP-V505 AHP-V506 AHP-V507	Flask Shutoff Valve #1 Flask Shutoff Valve #2 Flask Shutoff Valve #3
2	AIR SUPPLY NEXT RACK	AHP-V501	Flask Rack Isolation Valve
3	AIR SUPPLY OUT	AHP-V502	Flask Rack Isolation Valve
4	GAUGE ISOLATION	AHP-V503	Flask Rack Gauge Isolation Valve
5	AHP-V604	AHP-V604	Roof Rack Charge Inlet Valve
6	AIR SUPPLY THIS RACK	AHP-V504	Flask Rack Isolation Valve
7	MANIFOLD PRESSURE	AHP-G508	Flask Rack HP Pressure Gauge (0-4,000 psi)
8	N/A	AHP-G602	Roof Rack HP Pressure Gauge (0-4,000 psi)
9	N/A	AHP-V601	Roof Rack Gauge Isolation Valve
10	N/A	AHP-V603	Roof Rack HP Relief Valve

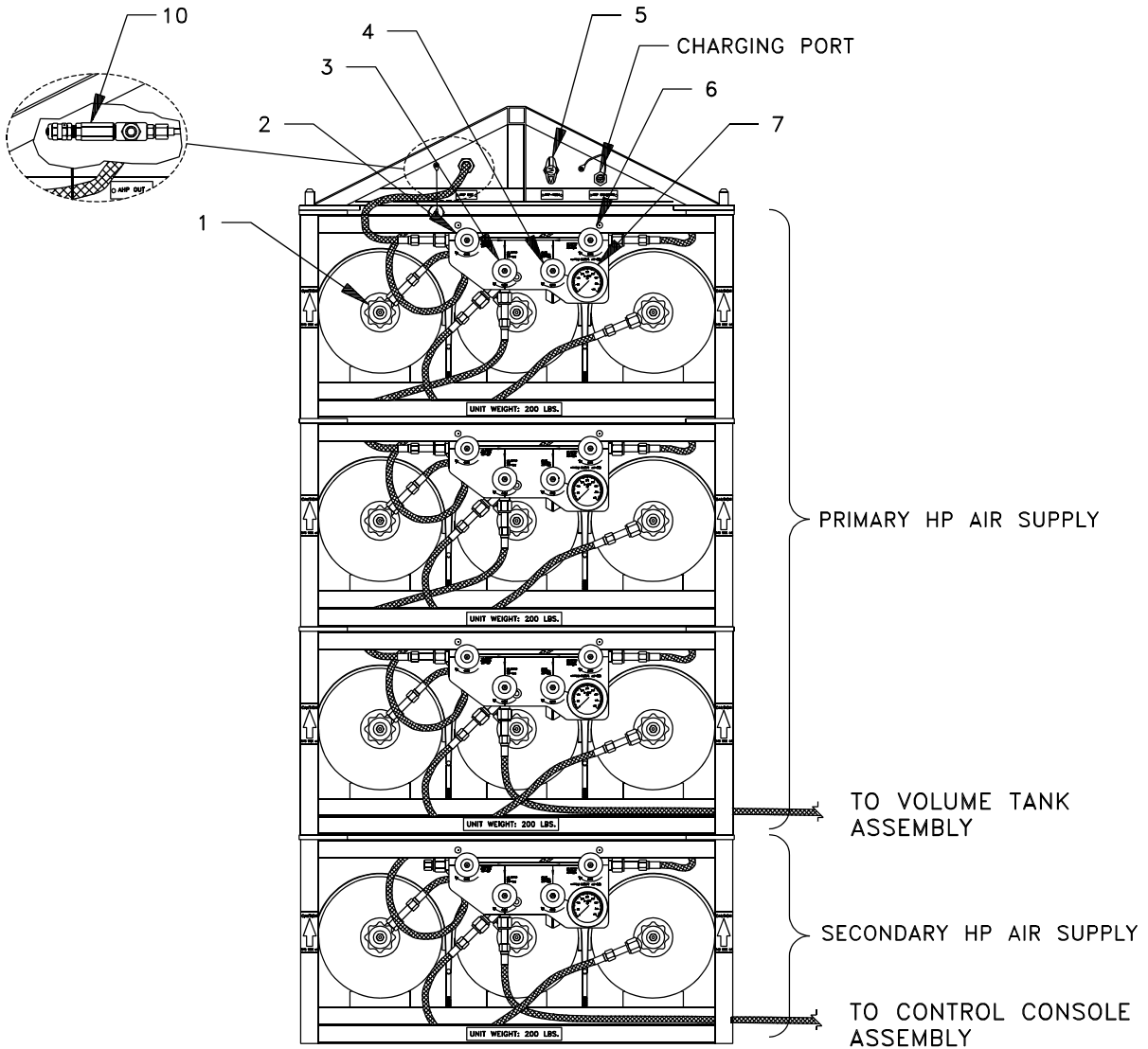


**Figure 2-3. Secondary HP Air Supply, Configuration 1**

### SS500-HK-MMO-010



(ROOF RACK ASSEMBLY OPPOSITE SIDE)



### MINIMUM REQUIREMENT

Figure 2-4. Primary and Secondary HP Air Supplies, Configuration 2

SS500-HK-MMO-010

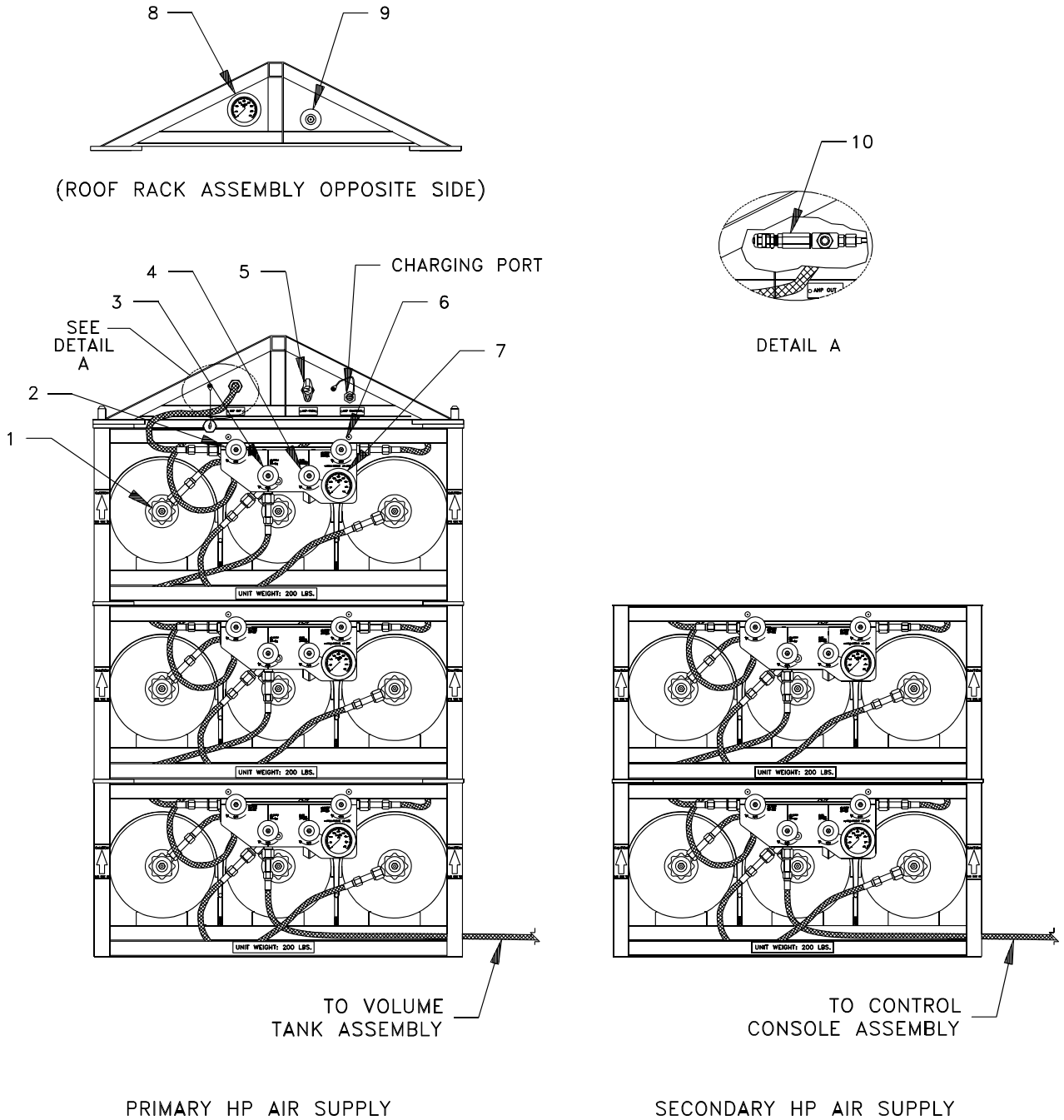
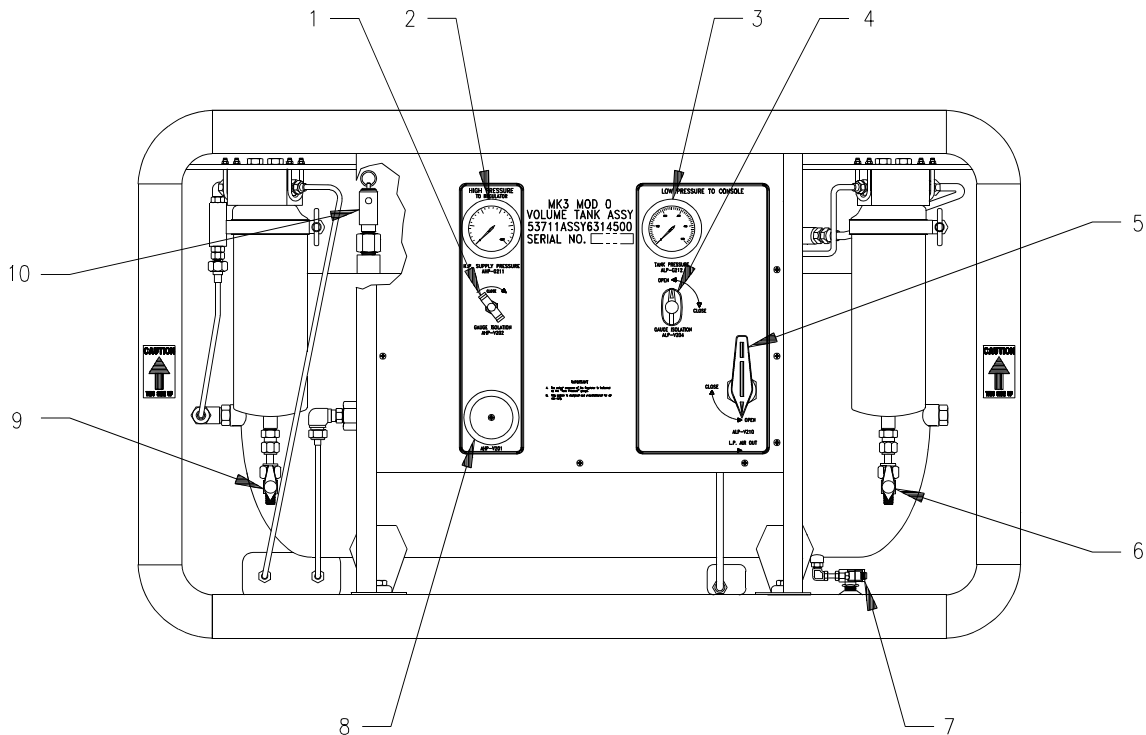


Figure 2-5. Primary and Secondary HP Air Supplies, Configuration 3

## SS500-HK-MMO-010

**Table 2-5. Volume Tank Assembly Controls and Indicators**  
(Refer to Figure 2-6)

Index No.	Panel Label	JID No.	Function
1	GAUGE ISOLATION	AHP-V202	HP Gauge Isolation Valve
2	H.P. SUPPLY PRESSURE	AHP-G211	HP Pressure Gauge (0-4,000 psi)
3	TANK PRESSURE	ALP-G212	LP Pressure Gauge (0-500 psi)
4	GAUGE ISOLATION	ALP-V204	LP (Tank Pressure) Gauge Isolation Valve
5	L.P. AIR OUT	ALP-V210	LP Supply Valve
6	N/A	ALP-V209	Final Filter Condensate Drain Valve
7	N/A	ALP-V208	Volume Tank Drain Valve
8	AHP-V201	AHP-V201	HP Regulator (Adjustment Knob)
9	N/A	ALP-V205	Pre-filter Condensate Drain Valve
10	N/A	ALP-V207	LP Relief Valve



**Figure 2-6. Volume Tank Assembly**

## SS500-HK-MMO-010

**Table 2-6. Control Console Assembly Controls and Indicators**  
(Refer to Figure 2-7)

Index No.	Panel Label	JID No.	Function
1	N/A	AHP-V307	Secondary Supply HP Regulator (Control Knob)
2	GAUGE ISOLATION	ALP-V310	Secondary Supply LP Out Gauge Isolation Valve
3	GAUGE ISOLATION	AHP-V309	Secondary Supply HP In Gauge Isolation Valve
4	HIGH PRESSURE IN	AHP-G316	Secondary Supply HP Pressure Gauge (0-4,000 psi)
5	LOW PRESSURE OUT	ALP-G317	Secondary Supply LP Pressure Gauge (0-500 psi)
6	DIVER AIR	ALP-V304	Red Diver's Air Supply Valve
7	N/A	ALP-G318	Red Diver's Depth Gauge (0-350 fsw)
8	DIVER DEPTH	ALP-V312	Red Diver's Pneumofathometer Air Valve
9	DIVER AIR	ALP-V305	Green Diver's Air Supply Valve
10	N/A	ALP-G319	Green Diver's Depth Gauge (0-350 fsw)
11	DIVER DEPTH	ALP-V313	Green Diver's Pneumofathometer Air Valve
12	DIVER AIR	ALP-V306	Yellow Diver's Air Supply Valve
13	N/A	ALP-G320	Yellow Diver's Depth Gauge (0-350 fsw)
14	DIVER DEPTH	ALP-V314	Yellow Diver's Pneumofathometer Air Valve
15	LOW PRESSURE SUPPLY	ALP-G315	Primary Supply LP Pressure Gauge (0-500 psi)
16	GAUGE ISOLATION	ALP-V301	Primary Supply LP Gauge Isolation Valve
17	SUPPLY SELECTOR VALVE	ALP-V302	Supply Selector Valve
18	N/A	ALP-V308	Secondary Supply LP Relief Valve

SS500-HK-MMO-010

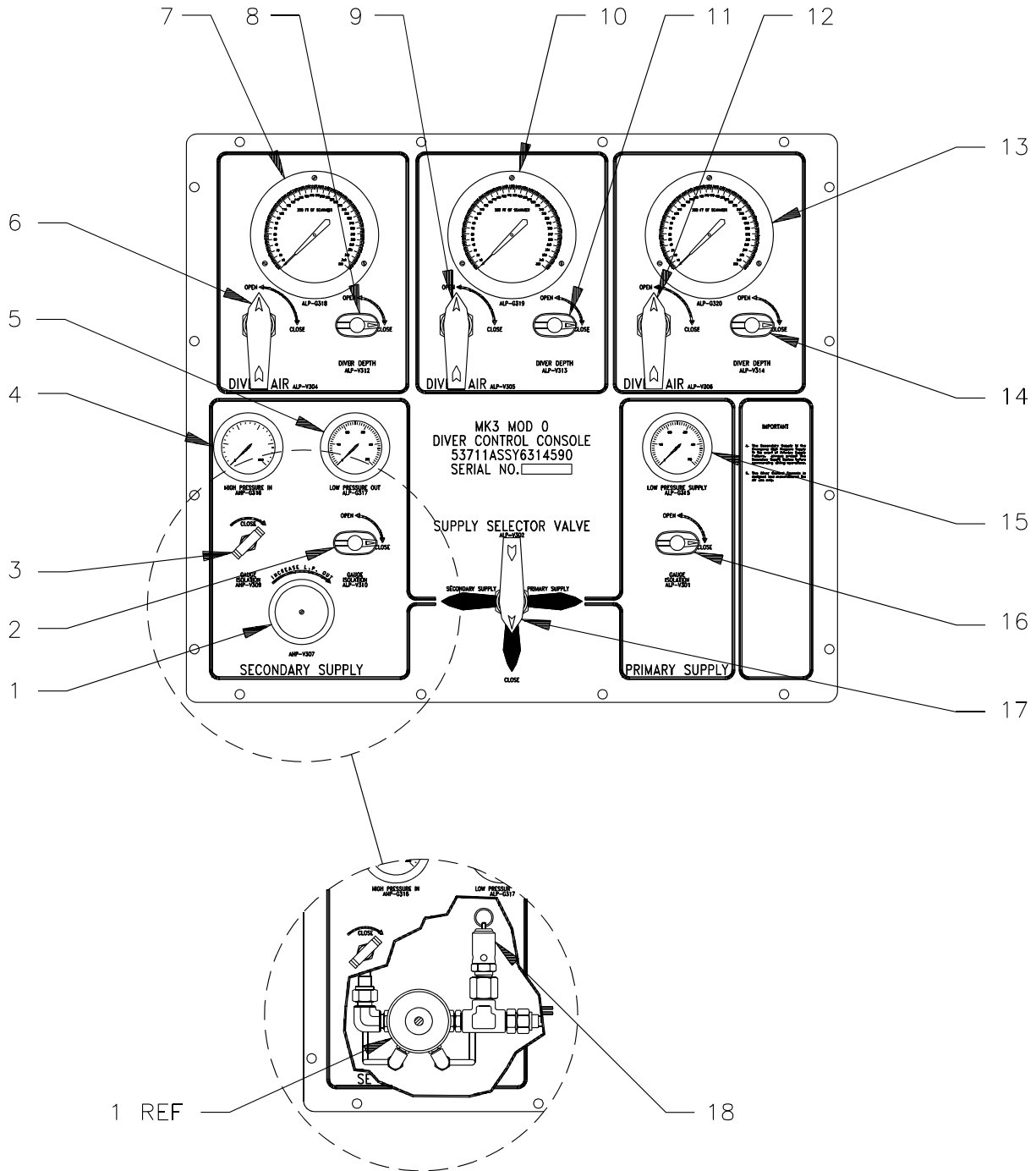


Figure 2-7. Control Console Assembly



## SS500-HK-MMO-010

## 2.3 OPERATING PROCEDURES

The flow chart in Figure 2-8 shows the general sequence of operating procedures for the LWDS MK 3 Mod 0 with cross-references to the corresponding table in this chapter and the Operating Procedure (OP) or Emergency Procedure (EP) checklist provided in Appendix A.

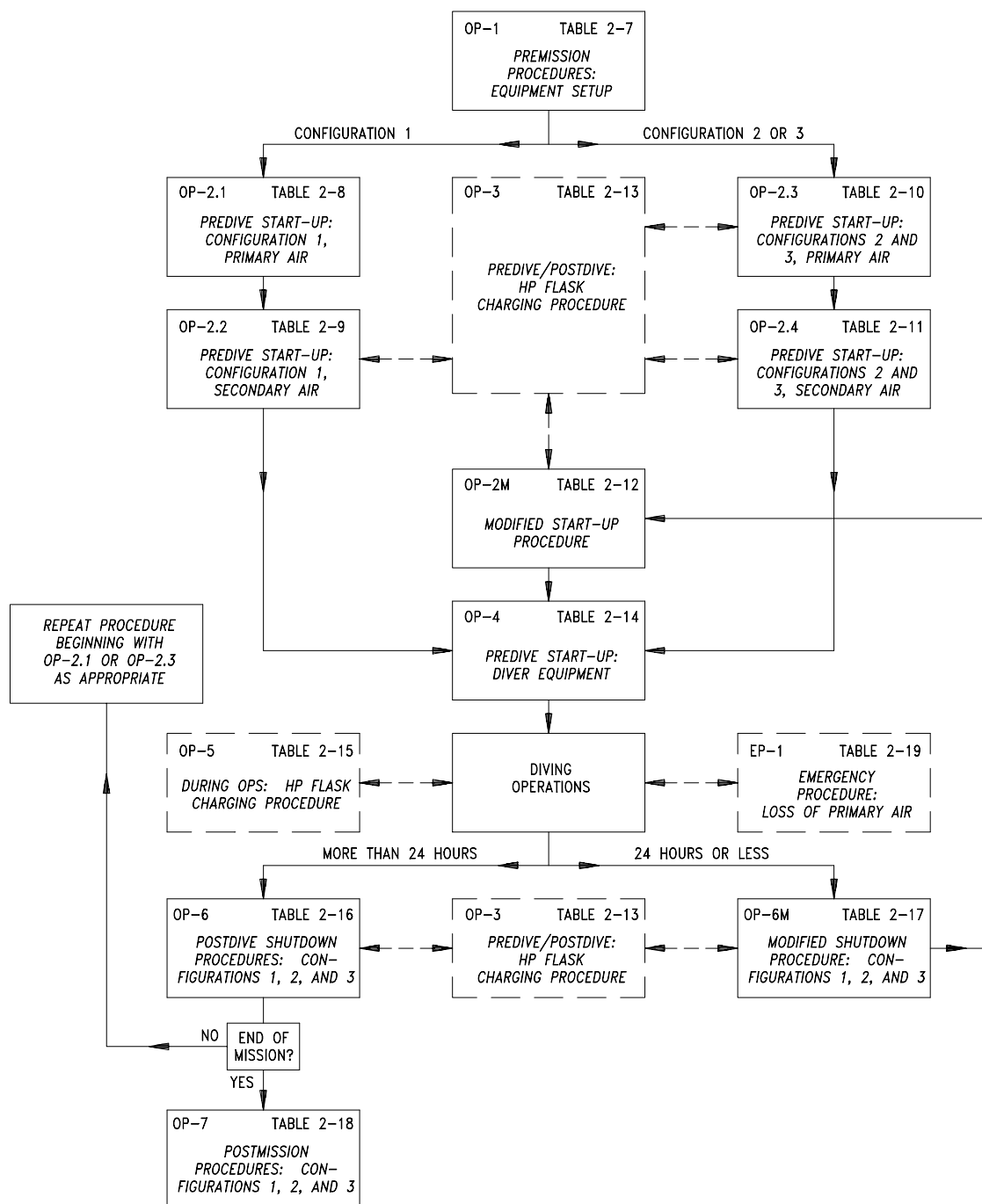


Figure 2-8. Operating and Emergency Procedures Flow Chart

## SS500-HK-MMO-010

**2.3.1 PREMISSION PROCEDURES: EQUIPMENT SETUP.** The procedures in Table 2-7 contain a detailed description of the steps necessary to set up and prepare the LWDS for operation in all configurations. Appendix A contains a corresponding operational checklist (OP-1) that may be photocopied for use during the equipment setup phase.

**Table 2-7. Prepermission Procedures: Equipment Setup**

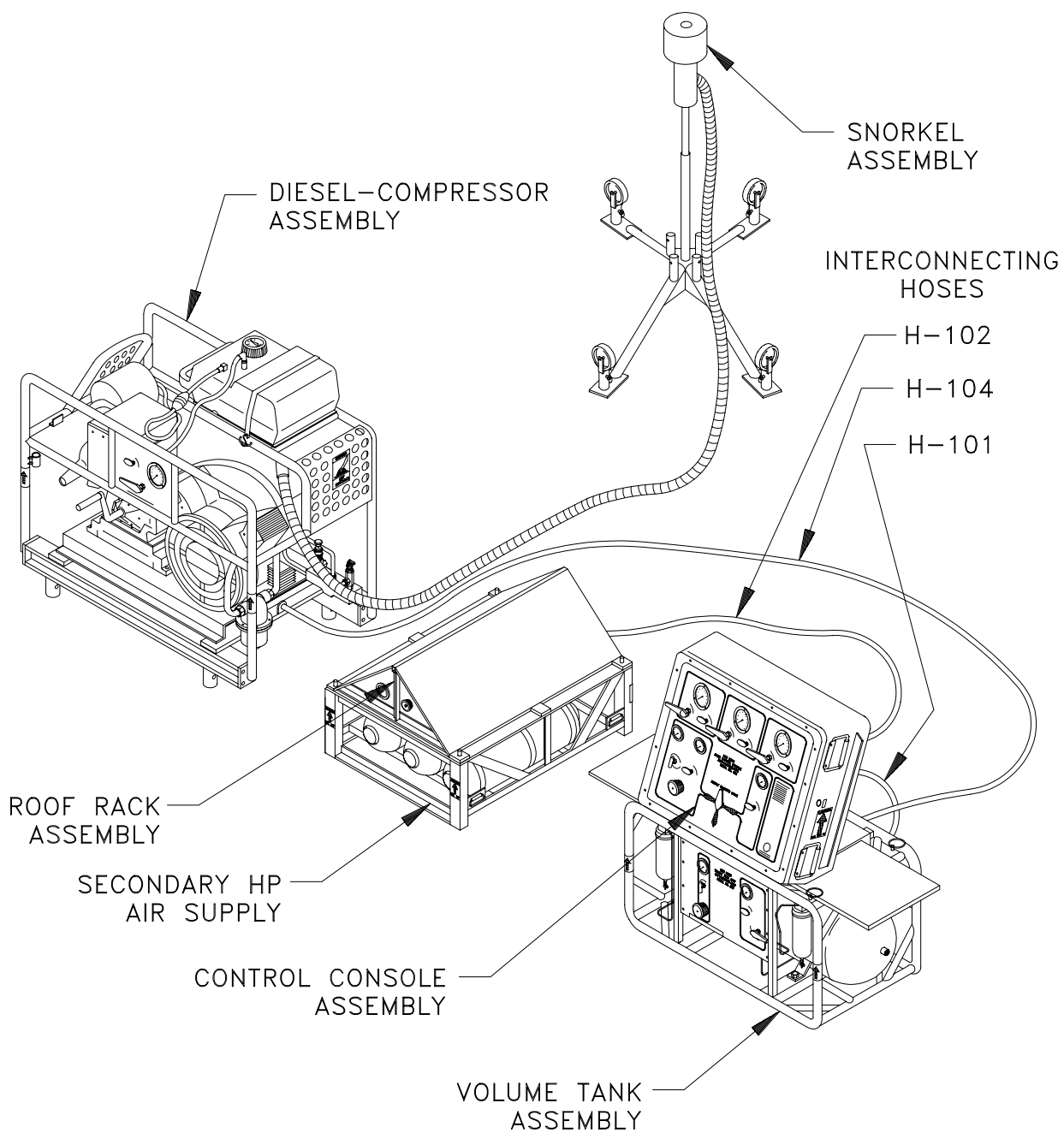
Step	Procedure		
	<p style="text-align: center;"><b>NOTES</b></p> <p>Record notes and deficiencies in section provided at the end of OP-1 in Appendix A.</p> <p>Perform steps 1 thru 3 in Part I for all configurations, then proceed to the appropriate section for the configuration being used.</p>		
<b>PART I - SYSTEM SETUP FOR CONFIGURATIONS 1, 2, AND 3</b>			
	<p style="text-align: center;"><b>WARNING</b></p> <p style="text-align: center;"><b>Adequately position, stabilize, and secure all equipment prior to operation as movement during operation could result in equipment damage and injury or death to personnel.</b></p>		
1	Remove volume tank assembly cover. Insert side tables and lockpins. Place control console platform on frame assembly and insert lockpins.		
2	Depress control console assembly breather valves. Remove control console assembly cover. Open rear panel. Insert support arms with pegs bent to rear of console and set unit on platform above volume tank assembly; pin in place.		
3	<p>Ensure the following valves are closed or unloaded:</p> <table border="0" style="width: 100%;"> <tr> <td style="vertical-align: top;"> <p><b><u>Volume Tank Assembly</u></b></p> <p>Regulator . . . . . AHP-V201</p> <p>Gauge Isolation . . . . . AHP-V202</p> <p>Gauge Isolation . . . . . ALP-V204</p> <p>Drain Valve . . . . . ALP-V205</p> <p>Drain Valve . . . . . ALP-V208</p> <p>Drain Valve . . . . . ALP-V209</p> <p>LP Air Out . . . . . ALP-V210</p> <p><b><u>Control Console Assembly</u></b></p> <p>Gauge Isolation . . . . . ALP-V301</p> <p>Supply Selector . . . . . ALP-V302</p> <p>Diver Air (Red) . . . . . ALP-V304</p> <p>Diver Air (Green) . . . . . ALP-V305</p> <p>Diver Air (Yellow) . . . . . ALP-V306</p> <p>Regulator . . . . . AHP-V307</p> <p>Gauge Isolation . . . . . AHP-V309</p> </td> <td style="vertical-align: top;"> <p><b><u>Control Console Assembly - Continued</u></b></p> <p>Gauge Isolation . . . . . ALP-V310</p> <p>Diver Depth (Red) . . . . . ALP-V312</p> <p>Diver Depth (Green) . . . . . ALP-V313</p> <p>Diver Depth (Yellow) . . . . . ALP-V314</p> <p><b><u>Flask Rack Assemblies</u></b></p> <p>Air Supply Next Rack . . . . . AHP-V501</p> <p>Air Supply Out . . . . . AHP-V502</p> <p>Gauge Isolation . . . . . AHP-V503</p> <p>Air Supply This Rack . . . . . AHP-V504</p> <p>Flask Valve . . . . . AHP-V505</p> <p>Flask Valve . . . . . AHP-V506</p> <p>Flask Valve . . . . . AHP-V507</p> <p><b><u>Roof Rack Assembly</u></b></p> <p>Gauge Isolation . . . . . AHP-V601</p> <p>Charge Inlet . . . . . AHP-V604</p> </td> </tr> </table>	<p><b><u>Volume Tank Assembly</u></b></p> <p>Regulator . . . . . AHP-V201</p> <p>Gauge Isolation . . . . . AHP-V202</p> <p>Gauge Isolation . . . . . ALP-V204</p> <p>Drain Valve . . . . . ALP-V205</p> <p>Drain Valve . . . . . ALP-V208</p> <p>Drain Valve . . . . . ALP-V209</p> <p>LP Air Out . . . . . ALP-V210</p> <p><b><u>Control Console Assembly</u></b></p> <p>Gauge Isolation . . . . . ALP-V301</p> <p>Supply Selector . . . . . ALP-V302</p> <p>Diver Air (Red) . . . . . ALP-V304</p> <p>Diver Air (Green) . . . . . ALP-V305</p> <p>Diver Air (Yellow) . . . . . ALP-V306</p> <p>Regulator . . . . . AHP-V307</p> <p>Gauge Isolation . . . . . AHP-V309</p>	<p><b><u>Control Console Assembly - Continued</u></b></p> <p>Gauge Isolation . . . . . ALP-V310</p> <p>Diver Depth (Red) . . . . . ALP-V312</p> <p>Diver Depth (Green) . . . . . ALP-V313</p> <p>Diver Depth (Yellow) . . . . . ALP-V314</p> <p><b><u>Flask Rack Assemblies</u></b></p> <p>Air Supply Next Rack . . . . . AHP-V501</p> <p>Air Supply Out . . . . . AHP-V502</p> <p>Gauge Isolation . . . . . AHP-V503</p> <p>Air Supply This Rack . . . . . AHP-V504</p> <p>Flask Valve . . . . . AHP-V505</p> <p>Flask Valve . . . . . AHP-V506</p> <p>Flask Valve . . . . . AHP-V507</p> <p><b><u>Roof Rack Assembly</u></b></p> <p>Gauge Isolation . . . . . AHP-V601</p> <p>Charge Inlet . . . . . AHP-V604</p>
<p><b><u>Volume Tank Assembly</u></b></p> <p>Regulator . . . . . AHP-V201</p> <p>Gauge Isolation . . . . . AHP-V202</p> <p>Gauge Isolation . . . . . ALP-V204</p> <p>Drain Valve . . . . . ALP-V205</p> <p>Drain Valve . . . . . ALP-V208</p> <p>Drain Valve . . . . . ALP-V209</p> <p>LP Air Out . . . . . ALP-V210</p> <p><b><u>Control Console Assembly</u></b></p> <p>Gauge Isolation . . . . . ALP-V301</p> <p>Supply Selector . . . . . ALP-V302</p> <p>Diver Air (Red) . . . . . ALP-V304</p> <p>Diver Air (Green) . . . . . ALP-V305</p> <p>Diver Air (Yellow) . . . . . ALP-V306</p> <p>Regulator . . . . . AHP-V307</p> <p>Gauge Isolation . . . . . AHP-V309</p>	<p><b><u>Control Console Assembly - Continued</u></b></p> <p>Gauge Isolation . . . . . ALP-V310</p> <p>Diver Depth (Red) . . . . . ALP-V312</p> <p>Diver Depth (Green) . . . . . ALP-V313</p> <p>Diver Depth (Yellow) . . . . . ALP-V314</p> <p><b><u>Flask Rack Assemblies</u></b></p> <p>Air Supply Next Rack . . . . . AHP-V501</p> <p>Air Supply Out . . . . . AHP-V502</p> <p>Gauge Isolation . . . . . AHP-V503</p> <p>Air Supply This Rack . . . . . AHP-V504</p> <p>Flask Valve . . . . . AHP-V505</p> <p>Flask Valve . . . . . AHP-V506</p> <p>Flask Valve . . . . . AHP-V507</p> <p><b><u>Roof Rack Assembly</u></b></p> <p>Gauge Isolation . . . . . AHP-V601</p> <p>Charge Inlet . . . . . AHP-V604</p>		

## SS500-HK-MMO-010

Table 2-7. Prepermission Procedures: Equipment Setup—Continued

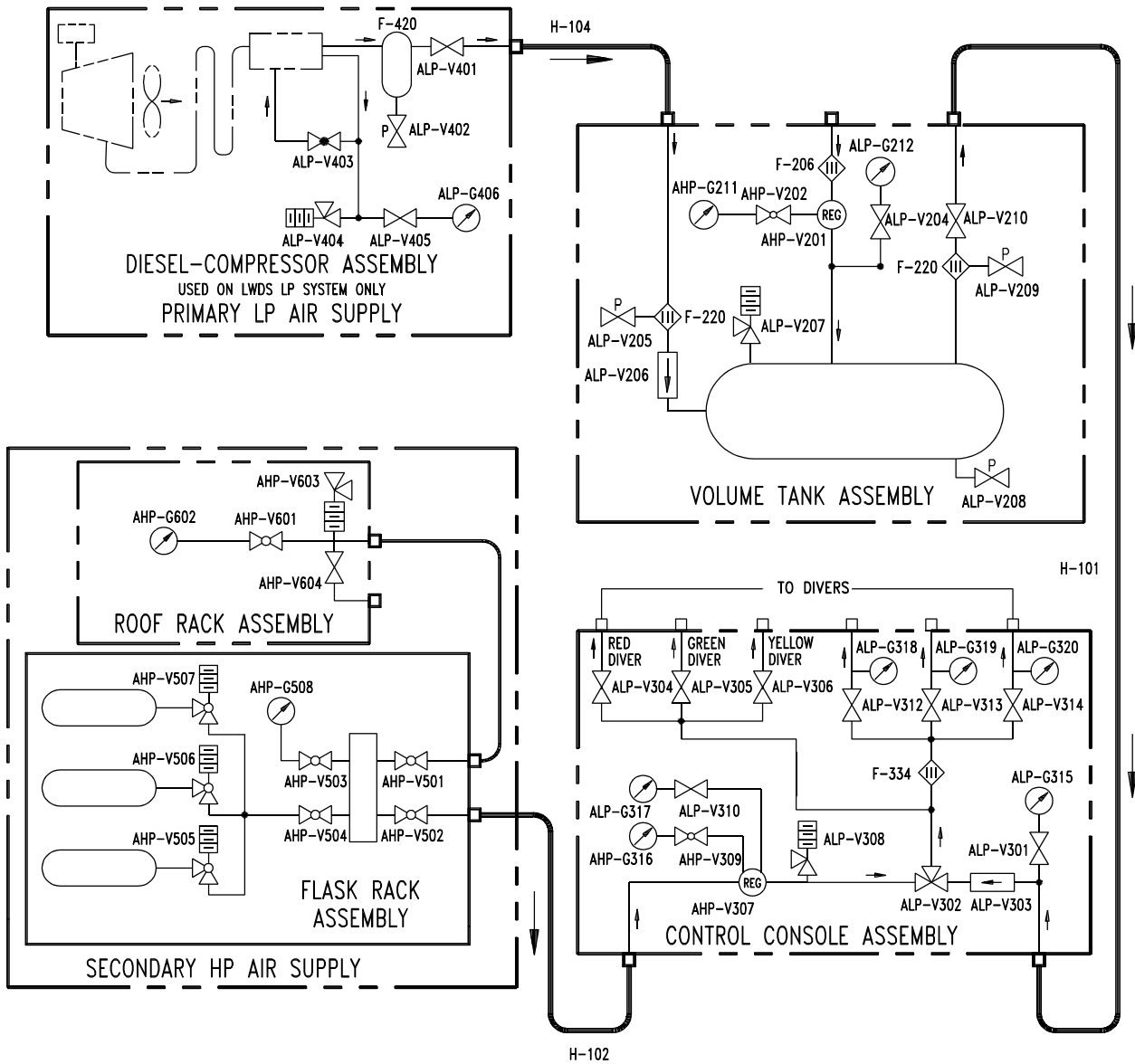
Step	Procedure
<b>PART II - CONFIGURATION 1 SETUP</b> (see Figures 2-9 and 2-10)	
<p><b>WARNINGS</b></p> <p>Do not place the compressor intake near the exhaust of any other equipment. The diesel exhaust silencer must be downwind of the snorkel assembly. Failure to observe this warning could result in injury or death to personnel breathing the compressed air.</p> <p>If the diesel-compressor assembly must operate in an enclosed space, provisions should be made for engine cooling, ventilation, noise, and diesel exhaust fume removal. Failure to comply with this warning may result in injury or death to personnel and damage to the equipment.</p>	
4	Place diesel-compressor assembly at desired location (within 150 feet of dive station). Remove wheels and place on snorkel assembly stand.
5	Position snorkel assembly upwind of compressor exhaust and connect air intake hose.
6	Position flask rack assembly (1 required) at desired location.
7	Place roof rack assembly (with gauged end away from flask rack controls) on top of flask rack assembly.
8	<p>Ensure the following diesel-compressor assembly valves are closed or unloaded:</p> <p>LP Air Out . . . . . ALP-V401    Gauge Isolation . . . . . ALP-V405  Drain Valve . . . . . ALP-V402</p>
<p><b>CAUTION</b></p> <p>Do not join more than three 50-foot sections of diesel-compressor to volume tank hose (H-104) together as it may cause the system to function improperly.</p>	
9	Connect 1/2-in. ID deck hose (H-104) to compressor air outlet bulkhead connector; secure safety cable to compressor frame tiedown ring. Connect male to female protective plug and cap. Ensure free end of hose remains capped.
10	Connect 1/2-in. ID deck hose (H-101) to volume tank <b>LP AIR OUT</b> bulkhead connector; secure safety cable to volume tank frame tiedown ring. Connect male to female protective plug and cap. Ensure free end of hose remains capped.
11	At secondary flask rack assembly: Disconnect flask whip from <b>AIR SUPPLY OUT</b> valve (AHP-V502). Loosen whip at <b>AIR SUPPLY NEXT RACK</b> valve (AHP-V501) and connect free end of whip to roof rack <b>AHP OUT</b> . Tighten both connectors.

### SS500-HK-MMO-010



**Figure 2-9. Lightweight Dive System (LWDS) MK 3 Mod 0, Configuration 1**

SS500-HK-MMO-010



CONFIGURATION 1

COMPONENT LEGEND

	PLUG VALVE		PRESSURE GAUGE		ANGLE SHUTOFF VALVE W/RELIEF
	BALL VALVE		REGULATOR MANUAL ADJUST		FILTER
	CHECK VALVE		SHUTOFF VALVE (NEEDLE)		PILOT VALVE
	RELIEF VALVE		ANGLE SHUTOFF VALVE (NEEDLE)		SELECTOR VALVE

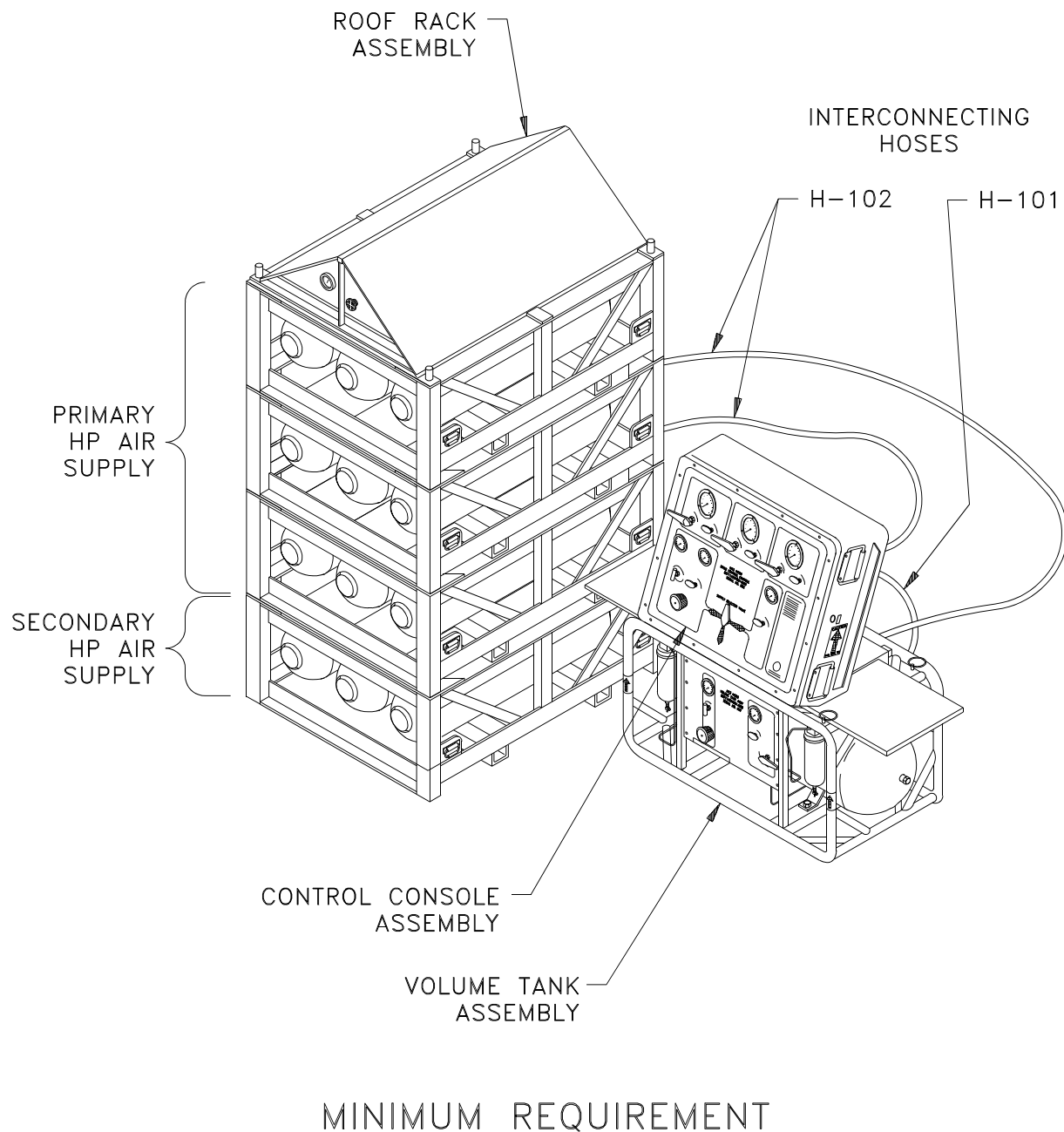
Figure 2-10. LWDS MK 3 Mod 0 Schematic, Configuration 1

## SS500-HK-MMO-010

**Table 2-7. Permission Procedures: Equipment Setup—Continued**

Step	Procedure
<b>PART II - CONFIGURATION 1 SETUP—Continued</b>	
12	Connect 30-ft deck hose (H-102) to secondary flask rack <b>AIR SUPPLY OUT</b> valve (AHP-V502) fitting; secure safety cable to flask rack frame lifting handle.
13	Connect free end of 30-ft deck hose (H-102) to control console <b>SECONDARY SUPPLY</b> HP bulkhead connector and secure safety cable to the volume tank frame tiedown ring. Connect male to female protective plug and cap.
<p><b>NOTE</b></p> <p>Proceed to Table 2-8, <i>Pre-dive Start-Up: Configuration 1, Primary Air.</i></p>	
<b>PART III - CONFIGURATION 2 SETUP</b> (see Figures 2-11 and 2-12)	
<p><b>NOTES</b></p> <p>Air calculations should always be performed to ensure adequate air is available for the dive.</p> <p>Ensure steps 1 thru 3 in Part I have been performed prior to proceeding.</p>	
4	Position secondary flask rack assembly (1 required) at desired location.
<p><b>NOTE</b></p> <p>Additional stacks of flask rack assemblies may be added if more than three primary flask rack assemblies are required for the dive mission. Do not exceed a total height of four assemblies in each stack.</p>	
5	Stack primary flask rack assemblies (3 required) on top of secondary flask rack assembly.
6	Place roof rack assembly (with gauged end away from flask rack controls) on top of last stack of primary flask rack assemblies.
<p><b>NOTE</b></p> <p>Proceed to Part V of this table and connect hoses in accordance with the procedure provided for the primary HP air supply.</p>	
<b>PART IV - CONFIGURATION 3 SETUP</b> (see Figures 2-13 and 2-14)	
<p><b>NOTE</b></p> <p>Air calculations should always be performed to ensure adequate air is available for the dive.</p>	

### SS500-HK-MMO-010



**Figure 2-11. Lightweight Dive System (LWDS) MK 3 Mod 0, Configuration 2**

SS500-HK-MMO-010

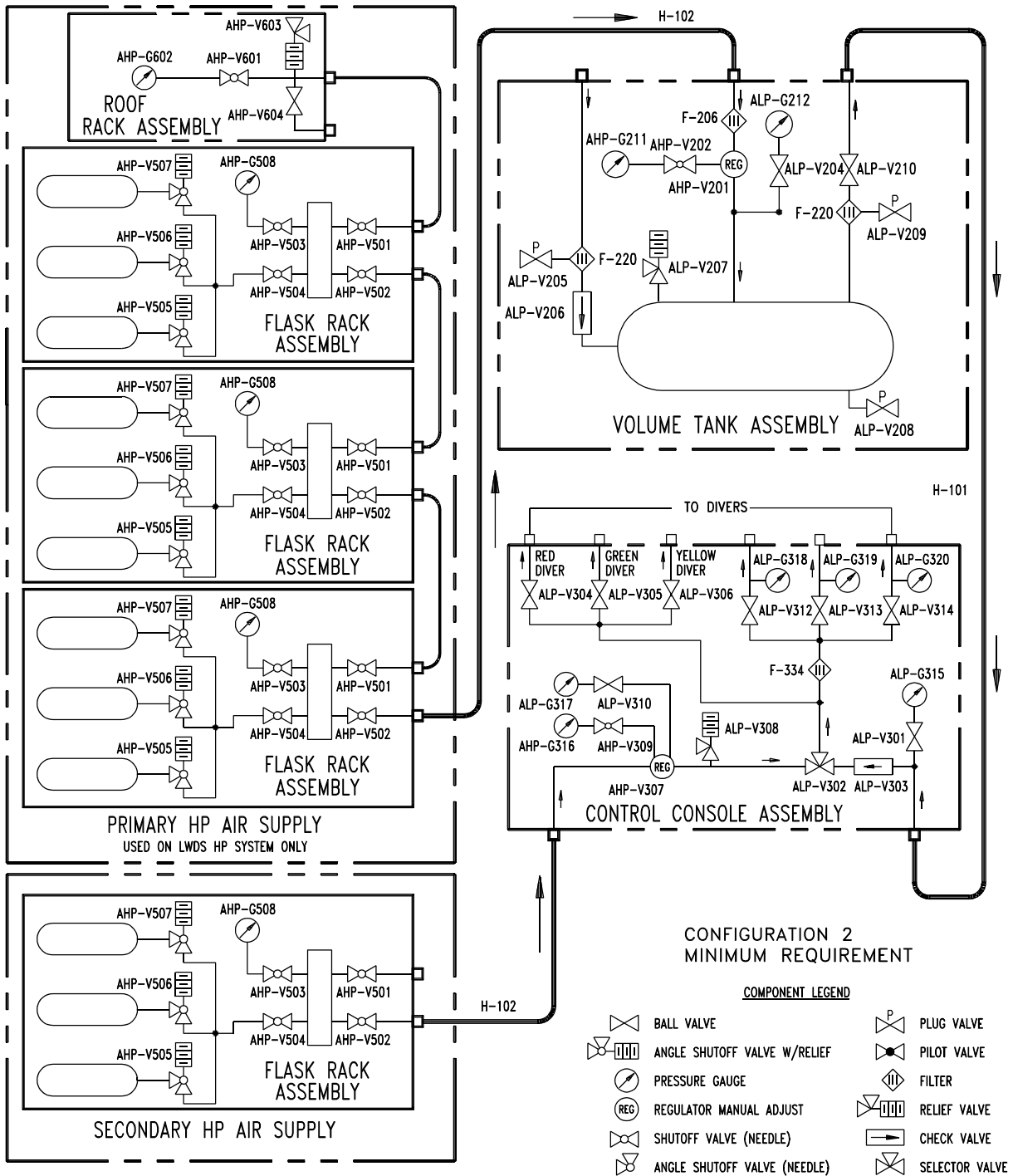
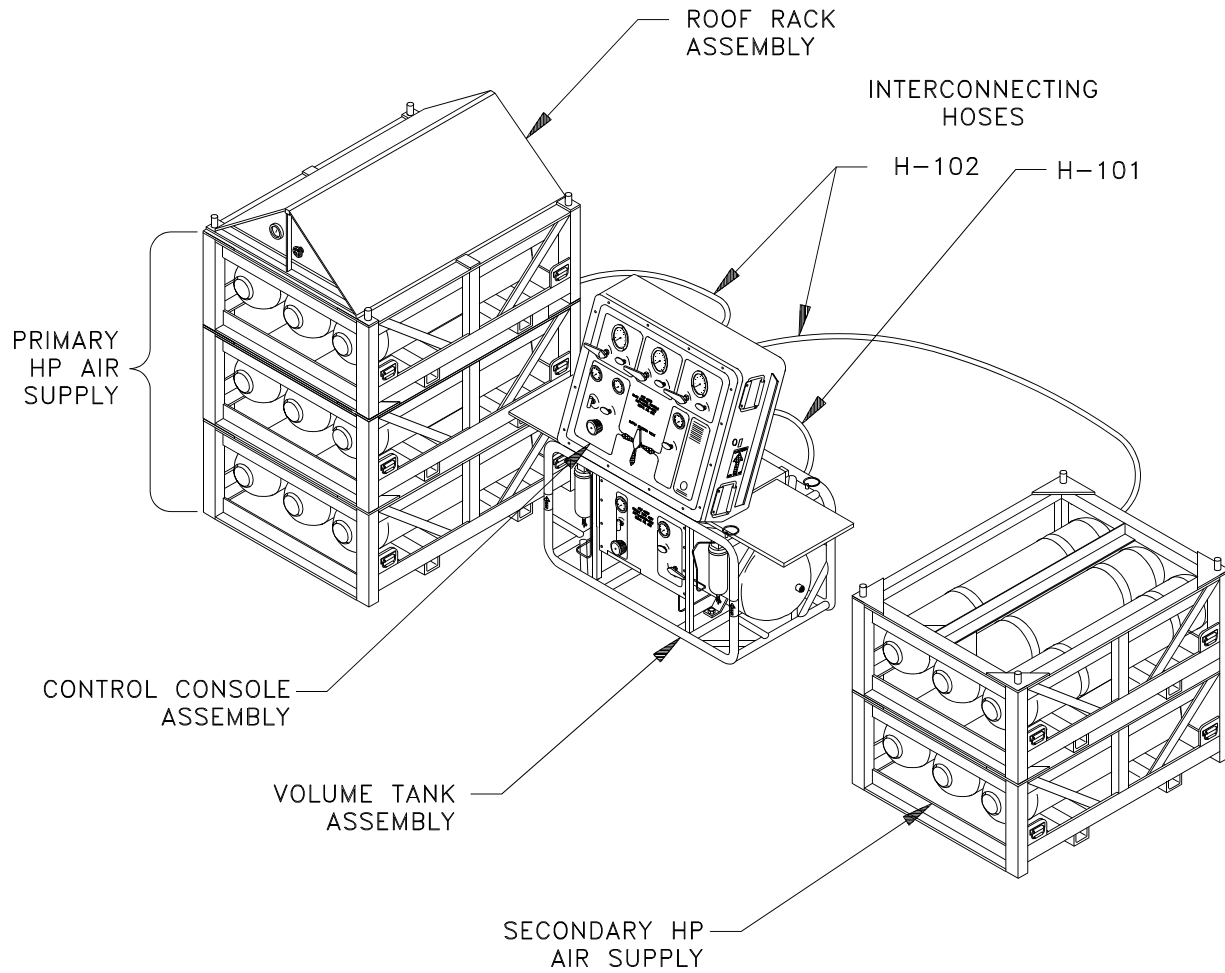


Figure 2-12. LWDS MK 3 Mod 0 Schematic, Configuration 2



### SS500-HK-MMO-010



### MINIMUM REQUIREMENT

**Figure 2-13. Lightweight Dive System (LWDS) MK 3 Mod 0, Configuration 3**

SS500-HK-MMO-010

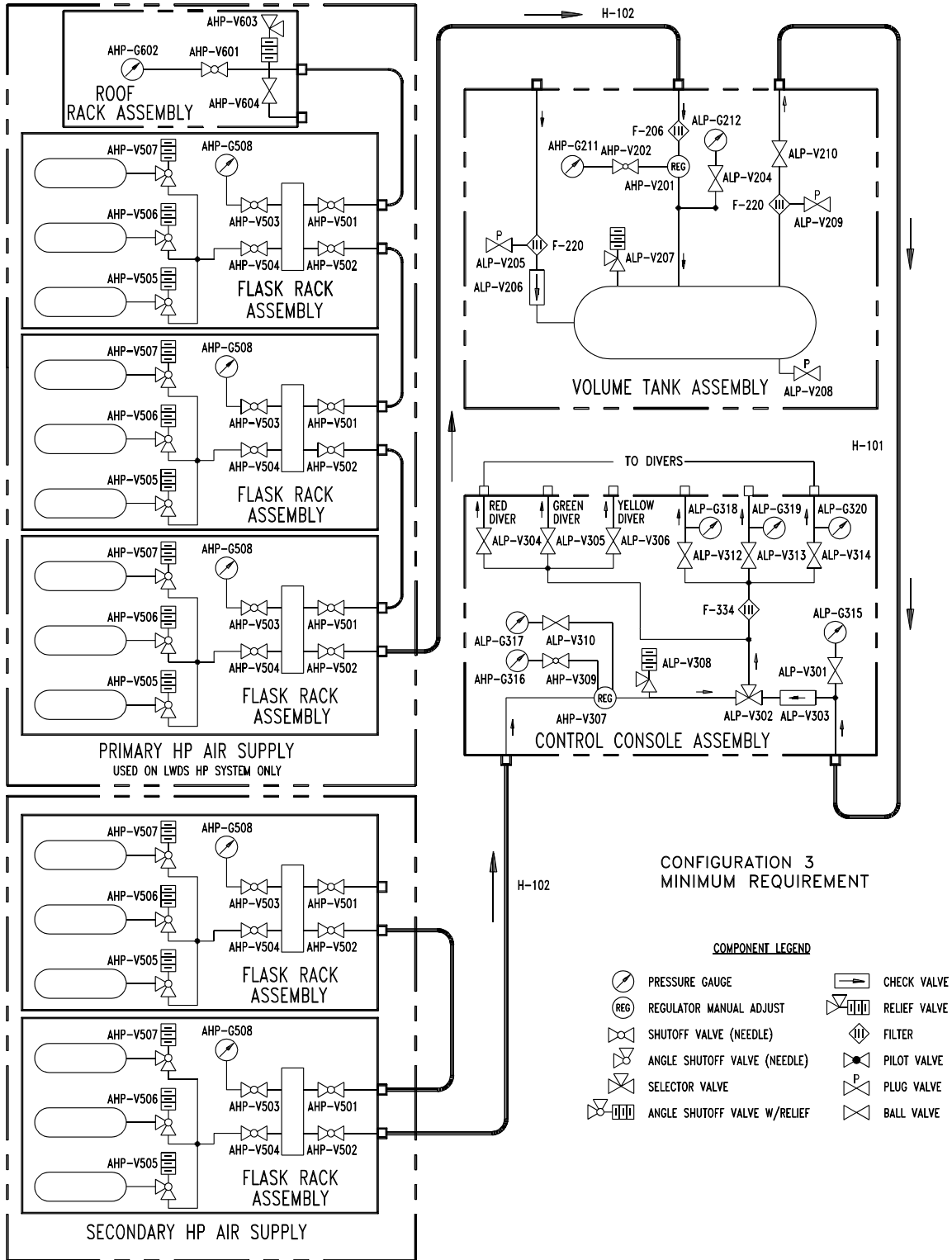


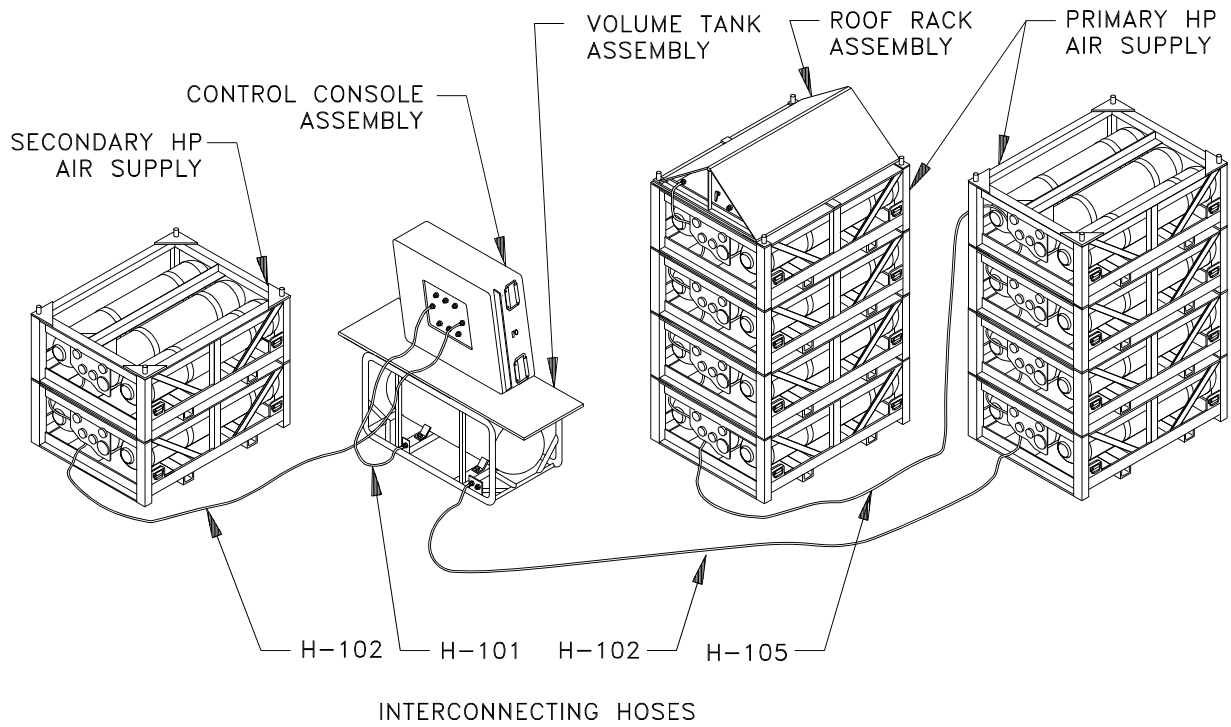
Figure 2-14. LWDS MK 3 Mod 0 Schematic, Configuration 3

## SS500-HK-MMO-010

Table 2-7. Prepermission Procedures: Equipment Setup—Continued

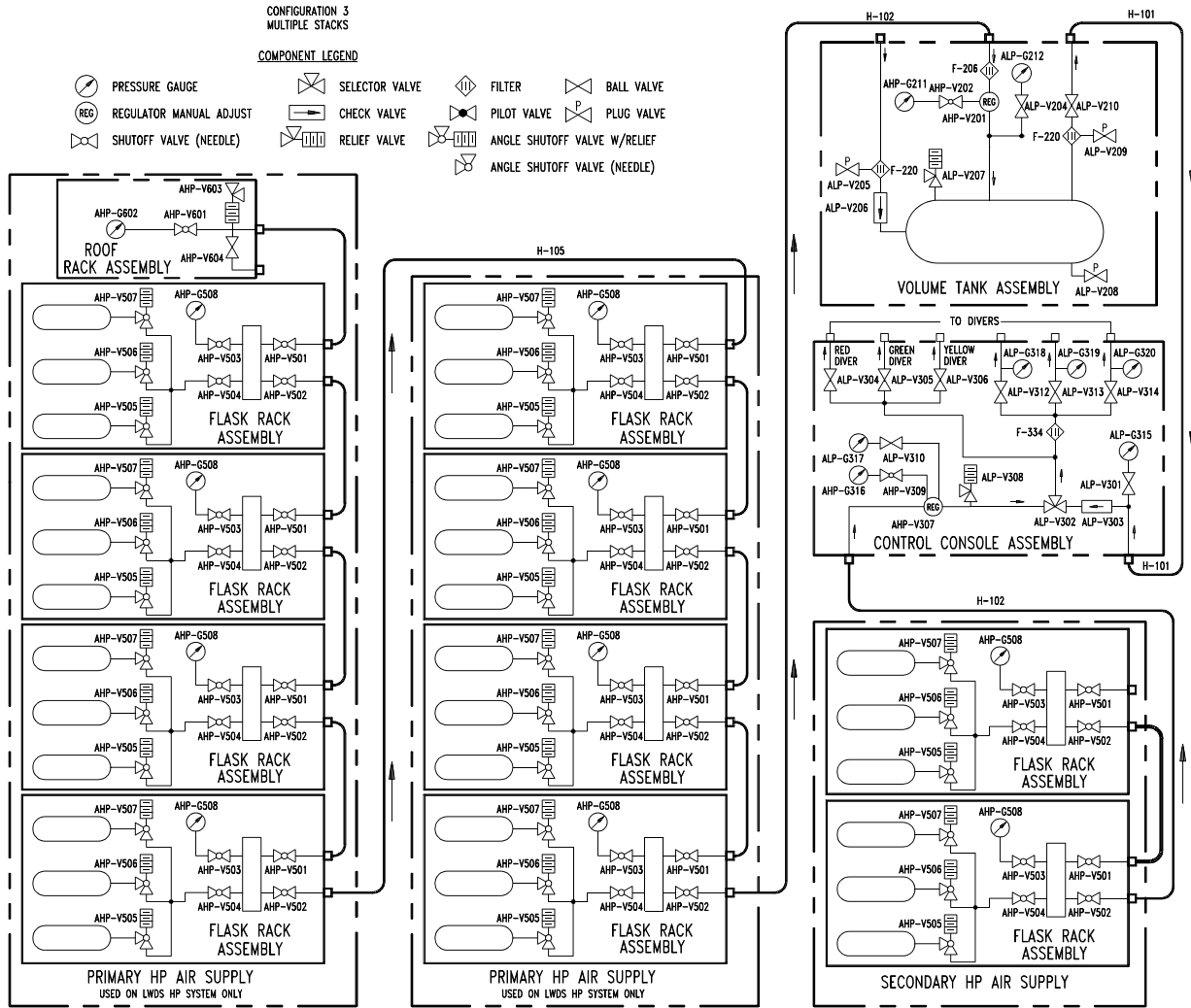
Step	Procedure
<b>PART IV - CONFIGURATION 3 SETUP—Continued</b>	
<b>NOTE</b> Ensure steps 1 thru 3 in Part I have been performed prior to proceeding.	
4	Stack a minimum of two secondary flask rack assemblies at desired location.
<b>NOTE</b> Additional stacks of flask rack assemblies may be added if more than four primary flask rack assemblies are required for the dive mission. Do not exceed a total height of four assemblies in each stack.	
5	Stack a minimum of three primary flask rack assemblies at desired location.
6	Place roof rack assembly (with gauged end away from flask rack controls) on top of single stack of racks as shown in Figures 2-13 and 2-14 or on top of last stack of racks in multiple stack configurations as shown in Figures 2-15 and 2-16.
<b>NOTE</b> Proceed to Part V of this table and connect hoses in accordance with the procedure provided for the primary HP air supply.	
<b>PART V - PRIMARY HP AIR SUPPLY HOSE CONNECTIONS FOR CONFIGURATIONS 2 AND 3</b>	
<b>NOTE</b> If using the minimum configuration, skip the secondary steps designated by light shading. If using a multiple stack configuration, perform the actions in the shaded steps in addition to or in place of the minimum configuration requirement.	
1	Disconnect flask whips from <b>AIR SUPPLY OUT</b> valve (AHP-V502) connectors on all primary flask racks, and loosen at <b>AIR SUPPLY NEXT RACK</b> valve (AHP-V501) connectors.
	First stack, top rack: Completely disconnect flask whip from <b>AIR SUPPLY NEXT RACK</b> valve (AHP-V501). Bag and stow whip.

SS500-HK-MMO-010



**Figure 2-15. Lightweight Dive System (LWDS) MK 3 Mod 0, Multiple Stacks of Flask Racks, Configuration 3**

# SS500-HK-MMO-010



**Figure 2-16. LWDS MK 3 Mod 0 Schematic, Multiple Stacks of Flask Racks, Configuration 3**

## SS500-HK-MMO-010

Table 2-7. Prepermission Procedures: Equipment Setup—Continued

Step	Procedure
<b>PART V - PRIMARY HP AIR SUPPLY HOSE CONNECTIONS FOR CONFIGURATIONS 2 AND 3—Continued</b>	
2	Interconnect racks as follows: Starting with lowest primary rack and working up, connect whip from each <b>AIR SUPPLY NEXT RACK</b> valve (AHP-V501) to <b>AIR SUPPLY OUT</b> valve (AHP-V502) on rack above. Connect highest primary rack <b>AIR SUPPLY NEXT RACK</b> valve (AHP-V501) to roof rack assembly <b>AHP OUT</b> . Tighten all connectors.
	Interconnect stacks as follows: Connect one end of deck hose (H-105) to first stack, top rack <b>AIR SUPPLY NEXT RACK</b> valve (AHP-V501) and the other end to next stack, bottom rack <b>AIR SUPPLY OUT</b> valve (AHP-V502). Repeat as needed for additional stacks.
3	Connect 30-ft deck hose (H-102) to lowest primary flask rack <b>AIR SUPPLY OUT</b> valve (AHP-V502) connector and secure safety cable to flask rack lifting handle.
	Connect deck hose (H-102) to <b>AIR SUPPLY OUT</b> valve (AHP-V502) on first stack, bottom rack of primary flask rack assemblies.
4	Connect free end of 30-ft deck hose (H-102) to volume tank <b>HP IN</b> bulkhead connector and secure safety cable to tiedown ring. Connect male to female protective plug and cap.
5	Connect 1/2-in. ID deck hose (H-101) to volume tank <b>LP AIR OUT</b> bulkhead connector; secure safety cable to volume tank frame tiedown rings. Connect male to female protective plug and cap. Ensure free end of hose remains capped.
<b>NOTE</b>  Proceed to Part VI or VII of this table and connect hoses in accordance with the procedure provided for the secondary HP air supply.	
<b>PART VI - SECONDARY HP AIR SUPPLY HOSE CONNECTIONS FOR CONFIGURATION 2</b>	
<b>NOTE</b>  The following procedure is for use with Configuration 2 when using a single flask rack assembly for the secondary HP air supply. If using multiple flask rack assemblies, follow the procedure in Part VII.	
1	Disconnect flask whip from secondary flask rack <b>AIR SUPPLY OUT</b> valve (AHP-V502). Cap or bag free end of whip.
2	Connect 30-ft HP deck hose (H-102) to secondary flask rack <b>AIR SUPPLY OUT</b> valve (AHP-V502) connector; secure safety cable to flask rack frame lifting handle. Connect AHP-V502 end cap and H-102 end plug to protect from debris.
3	Connect free end of 30-ft HP deck hose (H-102) to control console <b>SECONDARY SUPPLY</b> bulkhead connector and secure safety cable to the volume tank frame tiedown ring. Connect male to female protective plug and cap.

## SS500-HK-MMO-010

Table 2-7. Pre-mission Procedures: Equipment Setup—Continued

Step	Procedure
<b>PART VI - SECONDARY HP AIR SUPPLY HOSE CONNECTIONS FOR CONFIGURATION 2—Continued</b>	
<b>NOTE</b>  Proceed to Table 2-10, <i>Pre-dive Start-Up: Configurations 2 and 3, Primary Air.</i>	
<b>PART VII - SECONDARY HP AIR SUPPLY HOSE CONNECTIONS FOR CONFIGURATION 3</b>	
<b>NOTE</b>  The following procedure is for use with Configuration 3 or when using multiple flask rack assemblies for the secondary HP air supply. If using a single flask rack assembly, follow the procedure in Part VI.	
1	Disconnect flask whips from <b>AIR SUPPLY OUT</b> valves (AHP-V502) on all secondary flask rack assemblies, and loosen connectors at <b>AIR SUPPLY NEXT RACK</b> valves (AHP-V501) on all except highest rack. Cap or bag flask whip on highest rack.
2	Starting with the lowest secondary flask rack and working upward, connect the free end of each flask whip to <b>AIR SUPPLY OUT</b> valve (AHP-V502) connector on next highest rack. Tighten connectors.
3	Connect 30-ft HP deck hose (H-102) to lowest secondary flask rack <b>AIR SUPPLY OUT</b> valve (AHP-V502) connector; secure safety cable to flask rack frame lifting handle. Connect male to female protective plug and cap.
4	Connect free end of 30-ft HP deck hose (H-102) to control console <b>SECONDARY SUPPLY</b> bulkhead connector and secure safety cable to the volume tank frame tiedown ring. Connect male to female protective plug and cap.
<b>NOTE</b>  Proceed to Table 2-10, <i>Pre-dive Start-Up: Configurations 2 and 3, Primary Air.</i>	

## SS500-HK-MMO-010

**2.3.2 PREDIVE START-UP: CONFIGURATION 1, PRIMARY AIR.** The procedure in Table 2-8 contains a detailed description of the steps necessary to set up the primary air supply in Configuration 1 for the first dive of the mission and also for any dive that occurs after a break in operations of more than 24 hours. For dives that occur after a break of 24 hours or less, the modified start-up procedure in Table 2-12 may be used in place of the procedures in Tables 2-8 and 2-9 only if the modified shutdown procedure in Table 2-17 was performed before the break. Appendix A contains a corresponding operational checklist (OP-2.1) that may be photocopied for use during this phase of the prediver start-up.

**Table 2-8. Prediver Start-Up: Configuration 1, Primary Air**

Step	Procedure
	<p style="text-align: center;"><b>NOTE</b></p> <p>Record notes and deficiencies in section provided at the end of OP-2.1 in Appendix A.</p>
<b>PART I - DIESEL-COMPRESSOR ASSEMBLY START-UP PROCEDURE</b>	
	<p style="text-align: center;"><b>WARNINGS</b></p> <p><b>Do not fill the fuel tank while it is mounted on the diesel-compressor assembly. The fuel tank shall be disconnected and moved away from the immediate vicinity of the diving equipment prior to refueling. Failure to observe this warning could result in a fuel spill, creating an immediate fire hazard and possibly causing contamination of the diving equipment, all of which could result in injury or death to personnel and damage to the equipment.</b></p> <p><b>The LWDS is designed to operate in ambient temperatures of 40°-100°F. When operating in temperatures below 40°F, the diesel-compressor assembly requires the use of special fuels and lubricants. Failure to use the prescribed diesel fuel and lubricating oils could result in injury or death to divers or support personnel and damage to the equipment.</b></p> <p style="text-align: center;"><b>CAUTIONS</b></p> <p>Use diesel fuel only. Ensure fuel tank vent is open.</p> <p>Fuel contamination can cause damage to the fuel injection system resulting in engine failure.</p>
1	Check fuel level in diesel engine. Refuel as required (see Figure 2-17 for approved fuel).



## SS500-HK-MMO-010

Table 2-8. Predrive Start-Up: Configuration 1, Primary Air—Continued

Step	Procedure
<b>PART I - DIESEL-COMPRESSOR ASSEMBLY START-UP PROCEDURE—Continued</b>	
2	Prime diesel engine fuel line using primer bulb (squeeze 8-10 times).
3	Check oil level on diesel engine dipstick. Add oil as required (see Figure 2-17 for approved oils); do not overfill.
4	Check oil level in compressor sight glass. Add oil as required (see Figure 2-17 for approved oils). Fill to red dot; do not overfill.
5	Ensure <b>GAUGE ISOLATION</b> valve (ALP-V405) is opened fully CCW.
6	Ensure <b>LP AIR OUT</b> valve (ALP-V401) is closed fully CW.
7	Ensure pilot valve (ALP-V403) is in unloaded (upright) position.
8	Ensure engine decompressor lever is in <b>START</b> position (toward flywheel).
	<p><b>WARNING</b></p> <p>Allowing starter handle to rotate on the running shaft is dangerous and could result in injury or death to personnel.</p> <p><b>CAUTION</b></p> <p>Never stop the diesel engine with the decompressors. Failure to comply with this caution may result in valve damage to engine.</p>
9	Crank start diesel engine and pull engine decompressor lever to <b>RUN</b> position. Run for 3 to 5 minutes in the unloaded (upright) position.
10	Push pilot valve (ALP-V403) to horizontal position to load compressor.
11	Read pressure on <b>SUPPLY PRESSURE</b> gauge (ALP-G406) and record on OP-2.1 in Appendix A; reading should be 140 to 170 pounds per square inch gauge (psig).

Type	Minimum on Hand	Above 40°F	Below 40°F Above 5°F	Below 5°F
Diesel Fuel	6 gallons	VV-F-800, Grade DF-2	VV-F-800, Grade DF-1 or DF-2 with 2 oz/gal Commercial Anti-Gel Additive	VV-F-800, Grade DF-A or DF-1 with 2 oz/gal Commercial Anti-Gel Additive
Diesel Engine Lubricating Oil	2 quarts	MIL-L-2104C, SAE 30W	MIL-L-2104C, SAE 20W or 15W-40	MIL-L-2104C, SAE 5W or 5W-20
Compressor Lubricating Oil	2 quarts	MIL-L-17331 (2190 TEP)	MIL-L-17672 (2135 TH)	MIL-L-17672 (2135 TH)

Figure 2-17. Fuel and Lubrication Chart

## SS500-HK-MMO-010

Table 2-8. Pre-dive Start-Up: Configuration 1, Primary Air—Continued

Step	Procedure
<b>PART I - DIESEL-COMPRESSOR ASSEMBLY START-UP PROCEDURE—Continued</b>	
<p><b>WARNING</b></p> <p>For the following step, maintain a firm grip on the hose and point the free end away from personnel to avoid injury from flying debris.</p>	
12	Prior to first dive only: Uncap free end of 1/2-in. ID deck hose (H-104). Open <b>LP AIR OUT</b> valve (ALP-V401) CCW; blow out deck hose and ensure full flow; close valve CW.
<b>PART II - VOLUME TANK ASSEMBLY START-UP PROCEDURE</b>	
13	Prior to first dive only: Connect free end of 1/2-in. ID deck hose (H-104) to the <b>LP AIR IN</b> bulkhead connector; secure safety cable to volume tank frame tiedown ring. Connect male to female protective plug and cap.
14	Ensure <b>LP AIR OUT</b> valve (ALP-V210) is closed fully CW.
15	Open <b>GAUGE ISOLATION</b> valve (ALP-V204) fully CCW.
16	Slowly open diesel-compressor <b>LP AIR OUT</b> valve (ALP-V401) until fully CCW to pressurize volume tank.
17	Check compressor load and unload set points ( $145 \pm 5$ and $165 \pm 5$ psig, respectively) at the volume tank <b>TANK PRESSURE</b> gauge (ALP-G212) or at the diesel-compressor <b>SUPPLY PRESSURE</b> gauge (ALP-G406).
18	Open volume tank assembly drain valves (ALP-V205, ALP-V208, and ALP-V209) and moisture separator drain valve (ALP-V402) on diesel-compressor assembly. Allow moisture to drain from volume tank, filters, and moisture separator. Close valves.
<p><b>CAUTION</b></p> <p>Never stop the diesel engine with the decompressors. Failure to comply with this caution may result in valve damage to engine.</p>	
19	Pull up stop/run cable to stop diesel engine.
<p><b>WARNING</b></p> <p>If volume tank pressure drops during this procedure, volume tank check valve (ALP-V206) is faulty and must be replaced. Failure to comply with this warning may result in injury or death to personnel and damage to equipment.</p>	
20	Open moisture separator drain valve (ALP-V402) and allow air to bleed from LP deck hose (H-104); close valve.

## SS500-HK-MMO-010

Table 2-8. Pre-dive Start-Up: Configuration 1, Primary Air—Continued

Step	Procedure
<b>PART II - VOLUME TANK ASSEMBLY START-UP PROCEDURE—Continued</b>	
<p><b>WARNING</b></p> <p>For the following step, maintain a firm grip on the hose and point the free end away from personnel to avoid injury from flying debris.</p>	
21	Prior to first dive only: Uncap free end of 1/2-in. ID deck hose (H-101). Open <b>LP AIR OUT</b> valve (ALP-V210) CCW to blow out deck hose; ensure full flow; close valve CW.
<b>PART III - CONTROL CONSOLE ASSEMBLY START-UP PROCEDURE</b>	
22	Prior to first dive only: Connect 1/2-in. ID deck hose (H-101) to <b>PRIMARY SUPPLY</b> bulkhead connector; secure safety cable to volume tank frame tiedown ring. Connect male to female protective plug and cap.
23	Open primary supply <b>GAUGE ISOLATION</b> valve (ALP-V301) fully CCW.
24	Remove control console <b>DIVER AIR</b> and <b>DIVER DEPTH</b> bulkhead connector caps.
25	Slowly open volume tank <b>LP AIR OUT</b> valve (ALP-V210) until fully CCW to pressurize control console.
26	Switch control console <b>SUPPLY SELECTOR</b> valve (ALP-V302) to <b>PRIMARY SUPPLY</b> .
27	Open control console <b>DIVER AIR</b> valves (ALP-V304, ALP-V305, and ALP-V306) CCW to confirm full flow to divers. Close valves fully CW.
<p><b>WARNING</b></p> <p><b>DO NOT FULLY OPEN DIVER DEPTH VALVES (ALP-V312, ALP-V313, and ALP-V314). Failure to comply will damage the diver depth gauges and may cause injury to personnel.</b></p>	
28	Open control console <b>DIVER DEPTH</b> valves (ALP-V312, ALP-V313, and ALP-V314) <b>slightly</b> CCW to confirm flow. Close valves fully CW.
<p><b>NOTE</b></p> <p>Proceed to Table 2-9, <i>Pre-dive Start-Up: Configuration 1, Secondary Air</i>.</p>	

## SS500-HK-MMO-010

**2.3.3 PREDIVE START-UP: CONFIGURATION 1, SECONDARY AIR.** The procedure in Table 2-9 contains a detailed description of the steps necessary to set up the secondary air supply in Configuration 1 for the first dive of the mission and also for any dive that occurs after a break in operations of more than 24 hours. For dives that occur after a break of 24 hours or less, the modified start-up procedure in Table 2-12 may be used in place of the procedures in Tables 2-8 and 2-9 only if the modified shutdown procedure in Table 2-17 was performed before the break. Appendix A contains a corresponding operational checklist (OP-2.2) that may be photocopied for use during this phase of the prediver start-up.

**Table 2-9. Prediver Start-Up: Configuration 1, Secondary Air**

Step	Procedure
	<p style="text-align: center;"><b>NOTES</b></p> <p>Record notes and deficiencies in section provided at the end of OP-2.2 in Appendix A.</p> <p>If diving supervisor determines that flasks need to be charged before, during, or after performance of this procedure, refer to Table 2-13, <i>Prediver/Postdiver: HP Flask Charging Procedure</i>. Ensure that valves are returned to previous settings prior to continuing this procedure or beginning the next procedure.</p>
1	Open flask rack <b>GAUGE ISOLATION</b> valve (AHP-V503) fully CCW; back off CW 1/4 turn.
2	Open flask rack <b>AIR SUPPLY THIS RACK</b> valve (AHP-V504) fully CCW; back off CW 1/4 turn.
3	Open flask rack <b>AIR SUPPLY NEXT RACK</b> valve (AHP-V501) fully CCW; back off CW 1/4 turn.
4	Open roof rack <b>GAUGE ISOLATION</b> valve (AHP-V601) fully CCW; back off CW 1/4 turn.
5	Open flask shutoff valves (AHP-V505, AHP-V506, and AHP-V507) fully CCW; back off CW 1/4 turn.
6	Record flask rack pressure reading at <b>MANIFOLD PRESSURE</b> gauge (AHP-G508) (3,000 psig maximum / 2,700 psig minimum) on OP-2.2 (Appendix A). Compare reading with roof rack assembly pressure gauge (AHP-G602). If different, determine defective gauge and replace in accordance with appropriate procedure in Chapter 6.
7	Open control console <b>GAUGE ISOLATION</b> valve (AHP-V309) fully CCW; back off CW 1/4 turn.
8	Open control console <b>GAUGE ISOLATION</b> valve (ALP-V310) fully CCW.
9	Ensure control console manual adjust regulator (AHP-V307) is unloaded (turned fully CCW).
10	Open flask rack <b>AIR SUPPLY OUT</b> valve (AHP-V502) fully CCW; back off CW 1/4 turn.
11	Record pressure from control console <b>HIGH PRESSURE IN</b> gauge (AHP-G316) (3,000 psig maximum / 2,700 psig minimum) on OP-2.2 (Appendix A).

## SS500-HK-MMO-010

**Table 2-9. Pre-dive Start-Up: Configuration 1, Secondary Air—Continued**

Step	Procedure
	<p style="text-align: center;"><b>NOTE</b></p> <p style="text-align: center;"><b>Diving Supervisor:</b> Determine minimum manifold pressure.</p>
12	Turn control console manual adjust regulator (AHP-V307) control knob CW to increase low pressure out as directed by diving supervisor (do not exceed 250 psig on ALP-G317).
13	Switch control console <b>SUPPLY SELECTOR</b> valve (ALP-V302) to <b>SECONDARY SUPPLY</b> position.
14	Ensure <b>DIVER AIR</b> bulkhead connectors are uncapped. Open control console <b>DIVER AIR</b> valves (ALP-V304, ALP-V305, and ALP-V306) CCW to confirm full flow to divers. Close valves fully CW.
15	Switch control console <b>SUPPLY SELECTOR</b> valve (ALP-V302) to <b>CLOSE</b> position.
	<p style="text-align: center;"><b>NOTE</b></p> <p style="text-align: center;">Proceed to Table 2-14, <i>Pre-dive Start-Up: Diver Equipment</i>.</p>

## SS500-HK-MMO-010

**2.3.4 PREDIVE START-UP: CONFIGURATIONS 2 AND 3, PRIMARY AIR.** The procedure in Table 2-10 contains a detailed description of the steps necessary to set up the primary HP air supply in Configurations 2 and 3 for the first dive of the mission and also for any dive that occurs after a break in operations of more than 24 hours. For dives that occur after a break of 24 hours or less, the modified start-up procedure in Table 2-12 may be used in place of the procedures in Tables 2-10 and 2-11 only if the modified shutdown procedure in Table 2-17 was performed before the break. Appendix A contains a corresponding operational checklist (OP-2.3) that may be photocopied for use during this phase of the prediver start-up.

**Table 2-10. Prediver Start-Up: Configurations 2 and 3, Primary Air**

Step	Procedure
	<p style="text-align: center;"><b>NOTES</b></p> <p>Record notes and deficiencies in section provided at the end of OP-2.3 in Appendix A.</p> <p>Air calculations should always be performed to ensure adequate air is available for the dive.</p> <p>If diving supervisor determines that flasks need to be charged before, during, or after performance of this procedure, refer to Table 2-13, <i>Prediver/Postdiver: HP Flask Charging Procedure</i>. Ensure that valves are returned to previous settings prior to continuing this procedure or beginning the next procedure.</p> <p>If using the minimum configuration, skip the secondary steps designated by light shading. If using a multiple stack configuration, perform the actions in the shaded steps in addition to or in place of the minimum configuration requirement.</p>
<b>PART I - PRIMARY HP AIR SUPPLY START-UP PROCEDURE</b>	
1	Open all primary flask rack <b>GAUGE ISOLATION</b> valves (AHP-V503) and roof rack assembly <b>GAUGE ISOLATION</b> valve (AHP-V601) fully CCW; back off CW 1/4 turn.
2	Open all primary flask rack <b>AIR SUPPLY THIS RACK</b> valves (AHP-V504) fully CCW; back off CW 1/4 turn.
3	Open all primary flask rack flask shutoff valves (AHP-V505, AHP-V506, and AHP-V507) fully CCW; back off CW 1/4 turn.
	<p style="text-align: center;"><b>NOTE</b></p> <p>Notify the diving supervisor if primary flask rack pressure in step 4 is less than 3,000 psig.</p>
4	Check all primary flask rack <b>MANIFOLD PRESSURE</b> gauges (AHP-G508). Record each rack's pressure (3,000 psig maximum) on OP-2.3 in Appendix A.
5	Open all primary flask rack <b>AIR SUPPLY NEXT RACK</b> valves (AHP-V501) fully CCW; back off CW 1/4 turn.

## SS500-HK-MMO-010

Table 2-10. Pre-dive Start-Up: Configurations 2 and 3, Primary Air—Continued

Step	Procedure
<b>PART I - PRIMARY HP AIR SUPPLY START-UP PROCEDURE—Continued</b>	
<b>NOTE</b>  Do not open <b>AIR SUPPLY OUT</b> valve (AHP-V502) on lowest primary rack. In multiple stack configurations, do not open AHP-V502 on bottom rack of first stack.	
6	On all primary flask racks except for lowest rack, open <b>AIR SUPPLY OUT</b> valves (AHP-V502) fully CCW; back off CW 1/4 turn.
7	Check roof rack assembly pressure gauge (AHP-G602). Record system pressure (3,000 psig maximum) on OP-2.3 in Appendix A.
<b>NOTE</b>  <b>Diving Supervisor:</b> Ensure there is adequate primary flask rack pressure to accomplish mission.	
<b>PART II - VOLUME TANK ASSEMBLY START-UP PROCEDURE</b>	
8	Open volume tank <b>GAUGE ISOLATION</b> valve (AHP-V202) fully CCW; back off CW 1/4 turn.
9	Open volume tank <b>GAUGE ISOLATION</b> valve (ALP-V204) fully CCW.
10	Ensure volume tank manual adjust regulator (AHP-V201) is unloaded (turned fully CCW).
11	Ensure volume tank <b>LP AIR OUT</b> valve (ALP-V210) is closed fully CW.
12	Open lowest primary flask rack <b>AIR SUPPLY OUT</b> valve (AHP-V502) fully CCW; back off CW 1/4 turn.
	Open <b>AIR SUPPLY OUT</b> valve (AHP-V502) on bottom rack of first stack of primary flask rack assemblies.
13	Check volume tank <b>HP SUPPLY PRESSURE</b> gauge (AHP-G211). Record pressure (3,000 psig maximum) on OP-2.3 in Appendix A.
<b>NOTE</b>  <b>Diving Supervisor:</b> Determine minimum manifold pressure.	
14	Turn volume tank manual adjust regulator (AHP-V201) CW to increase low pressure out as directed by diving supervisor (do not exceed 250 psig on <b>TANK PRESSURE</b> gauge (ALP-G212)).

## SS500-HK-MMO-010

Table 2-10. Pre-dive Start-Up: Configurations 2 and 3, Primary Air—Continued

Step	Procedure
<b>PART II - VOLUME TANK ASSEMBLY START-UP PROCEDURE</b>	
15	Open volume tank drain valve (ALP-V208) CCW to drain moisture from volume tank assembly. Close valve fully CW.
	<p><b>WARNING</b></p> <p><b>For the following step, maintain a firm grip on the hose and point the free end away from personnel to avoid injury from flying debris.</b></p>
16	Prior to first dive only: Uncap free end of 1/2-in. ID deck hose (H-101). Open volume tank <b>LP AIR OUT</b> valve (ALP-V210), blow out deck hose, and ensure full flow; close valve.
17	Prior to first dive only: Connect free end of 1/2-in. ID deck hose (H-101) to control console <b>PRIMARY SUPPLY</b> bulkhead connector; secure safety cable to volume tank frame. Connect male to female protective plug and cap.
<b>PART III - CONTROL CONSOLE ASSEMBLY START-UP PROCEDURE</b>	
18	Open control console primary supply <b>GAUGE ISOLATION</b> valve (ALP-V301) fully CCW.
19	Remove control console <b>DIVER AIR</b> and <b>DIVER DEPTH</b> bulkhead connector caps.
20	Slowly open volume tank <b>LP AIR OUT</b> valve (ALP-V210) until fully CCW to pressurize control console.
21	Check control console <b>LOW PRESSURE SUPPLY</b> gauge (ALP-G315). Record primary air pressure on OP-2.3 in Appendix A.
22	Switch control console <b>SUPPLY SELECTOR</b> valve (ALP-V302) to <b>PRIMARY SUPPLY</b> .
23	Open control console <b>DIVER AIR</b> valves (ALP-V304, ALP-V305, and ALP-V306) CCW to confirm full flow to divers; close valves fully CW.
	<p><b>WARNING</b></p> <p><b>DO NOT FULLY OPEN DIVER DEPTH VALVES (ALP-V312, ALP-V313, and ALP-V314). Failure to comply will damage the diver depth gauges and may cause injury to personnel.</b></p>
24	Open control console <b>DIVER DEPTH</b> valves (ALP-V312, ALP-V313, and ALP-V314) <b>slightly</b> CCW to confirm flow; close valves fully CW.



SS500-HK-MMO-010

**Table 2-10. Pre-dive Start-Up: Configurations 2 and 3, Primary Air—Continued**

Step	Procedure
	<p style="text-align: center;"><b>NOTE</b></p> <p>Proceed to Table 2-11, <i>Pre-dive Start-Up: Configurations 2 and 3, Secondary Air</i>.</p>

## SS500-HK-MMO-010

**2.3.5 PREDIVE START-UP: CONFIGURATIONS 2 AND 3, SECONDARY AIR.** The start-up procedure in Table 2-11 contains a detailed description of the steps necessary to set up the secondary HP air supply in Configurations 2 and 3 for the first dive of the mission and also for any dive that occurs after a break in operations of more than 24 hours. For dives that occur after a break of 24 hours or less, the modified start-up procedure in Table 2-12 may be used in place of the procedures in Tables 2-10 and 2-11 only if the modified shutdown procedure in Table 2-17 was performed before the break. Appendix A contains a corresponding operational checklist (OP-2.4) that may be photocopied for use during this phase of the prediver start-up.

**Table 2-11. Prediver Start-Up: Configurations 2 and 3, Secondary Air**

Step	Procedure
<p><b>NOTES</b></p> <p>Record notes and deficiencies in section provided at the end of OP-2.4 in Appendix A.</p> <p>Air calculations should always be performed to ensure adequate air is available for the dive.</p> <p>If diving supervisor determines that flasks need to be charged before, during, or after performance of this procedure, refer to Table 2-13, <i>Prediver/Postdive: HP Flask Charging Procedure</i>. Ensure that valves are returned to previous settings prior to continuing this procedure or beginning the next procedure.</p>	
<p><b>PART I - CONFIGURATION 2: SECONDARY HP AIR SUPPLY AND CONTROL CONSOLE ASSEMBLY START-UP PROCEDURE</b></p>	
1	Open secondary flask rack <b>GAUGE ISOLATION</b> valve (AHP-V503) fully CCW; back off CW 1/4 turn.
2	Open secondary flask rack <b>AIR SUPPLY THIS RACK</b> valve (AHP-V504) fully CCW; back off CW 1/4 turn.
3	Open secondary flask rack flask shutoff valves (AHP-V505, AHP-V506, and AHP-V507) fully CCW; back off CW 1/4 turn.
4	Record secondary flask rack pressure reading at <b>MANIFOLD PRESSURE</b> gauge (AHP-G508) (3,000 psig maximum / 2,700 psig minimum) on OP-2.4 in Appendix A.
5	Open control console <b>GAUGE ISOLATION</b> valve (AHP-V309) fully CCW; back off CW 1/4 turn.
6	Open control console <b>GAUGE ISOLATION</b> valve (ALP-V310) fully CCW; back off CW 1/4 turn.
7	Ensure control console manual adjust regulator (AHP-V307) is unloaded (turned fully CCW).
8	Open secondary flask rack <b>AIR SUPPLY OUT</b> valve (AHP-V502) fully CCW; back off CW 1/4 turn.
9	Record pressure from control console <b>HIGH PRESSURE IN</b> gauge (AHP-G316) (3,000 psig maximum / 2,700 psig minimum) on OP-2.4 in Appendix A.

## SS500-HK-MMO-010

Table 2-11. Prediver Start-Up: Configurations 2 and 3, Secondary Air—Continued

Step	Procedure
<b>PART I - CONFIGURATION 2: SECONDARY HP AIR SUPPLY AND CONTROL CONSOLE ASSEMBLY START-UP PROCEDURE—Continued</b>	
<b>NOTE</b>  <b>Diving Supervisor:</b> For the following step, refer to the minimum manifold pressure established in Table 2-10.	
10	Turn control console manual adjust regulator (AHP-V307) CW to increase low pressure out as directed by diving supervisor (do not exceed 250 psig on ALP-G317).
11	Switch control console <b>SUPPLY SELECTOR</b> valve (ALP-V302) to <b>SECONDARY SUPPLY</b> .
12	Ensure control console <b>DIVER AIR</b> bulkhead connectors are uncapped. Open control console <b>DIVER AIR</b> valves (ALP-V304, ALP-V305, and ALP-V306) CCW to confirm full flow to divers. Close valves fully CW.
13	Switch control console <b>SUPPLY SELECTOR</b> valve (ALP-V302) to <b>CLOSE</b> .
<b>NOTE</b>  Proceed to Table 2-14, <i>Prediver Start-Up: Diver Equipment</i> .	
<b>PART II - CONFIGURATION 3: SECONDARY HP AIR SUPPLY AND CONTROL CONSOLE ASSEMBLY START-UP PROCEDURE</b>	
1	Open all secondary flask rack <b>GAUGE ISOLATION</b> valves (AHP-V503) fully CCW; back off CW 1/4 turn.
2	Open all secondary flask rack <b>AIR SUPPLY THIS RACK</b> valves (AHP-V504) fully CCW; back off CW 1/4 turn.
3	Open all secondary flask rack flask shutoff valves (AHP-V505, AHP-V506, and AHP-V507) fully CCW; back off CW 1/4 turn.
4	Record secondary flask rack pressure reading at <b>MANIFOLD PRESSURE</b> gauge(s) (AHP-G508) (3,000 psig maximum / 2,700 psig minimum) on OP-2.4 in Appendix A.
5	Open control console <b>GAUGE ISOLATION</b> valve (AHP-V309) fully CCW; back off CW 1/4 turn.
6	Open control console <b>GAUGE ISOLATION</b> valve (ALP-V310) fully CCW; back off CW 1/4 turn.
7	Ensure control console manual adjust regulator (AHP-V307) is unloaded (turned fully CCW).
8	Open all secondary flask rack <b>AIR SUPPLY OUT</b> valves (AHP-V502) fully CCW; back off CW 1/4 turn.
9	Record pressure from control console <b>HIGH PRESSURE IN</b> gauge (AHP-G316) (3,000 psig maximum / 2,700 psig minimum) on OP-2.4 in Appendix A.

## SS500-HK-MMO-010

Table 2-11. Pre-dive Start-Up: Configurations 2 and 3, Secondary Air—Continued

Step	Procedure
<b>PART II - CONFIGURATION 3: SECONDARY HP AIR SUPPLY AND CONTROL CONSOLE ASSEMBLY START-UP PROCEDURE—Continued</b>	
<b>NOTE</b> <b>Diving Supervisor:</b> For the following step, refer to the minimum manifold pressure established in Table 2-10.	
10	Turn control console manual adjust regulator (AHP-V307) control knob CW to increase low pressure out as directed by diving supervisor (do not exceed 250 psig on ALP-G317).
11	Switch control console <b>SUPPLY SELECTOR</b> valve (ALP-V302) to <b>SECONDARY SUPPLY</b> .
12	Ensure control console <b>DIVER AIR</b> bulkhead connectors are uncapped. Open control console <b>DIVER AIR</b> valves (ALP-V304, ALP-V305, and ALP-V306) CCW to confirm full flow to divers. Close valves fully CW.
13	Switch control console <b>SUPPLY SELECTOR</b> valve (ALP-V302) to <b>CLOSE</b> .
<b>NOTE</b> Proceed to Table 2-14, <i>Pre-dive Start-Up: Diver Equipment</i> .	

THIS PAGE INTENTIONALLY LEFT BLANK

## SS500-HK-MMO-010

**2.3.6 MODIFIED START-UP PROCEDURE.** The procedure in Table 2-12 is an optional start-up procedure that may be performed only if the modified shutdown procedure in Table 2-17 was performed during the last shutdown and 24 hours or less have elapsed; otherwise, the start-up procedures in Tables 2-8/2-9 (for Configuration 1) or Tables 2-10/2-11 (for Configurations 2 and 3) must be used. Appendix A contains a corresponding operational checklist (OP-2M) that may be photocopied for use during the modified start-up procedure.

**Table 2-12. Modified Start-Up Procedure**

Step	Procedure
	<p style="text-align: center;"><b>NOTES</b></p> <p>Record notes and deficiencies in section provided at end of OP-2M in Appendix A.</p> <p>If flasks require charging immediately before, during, or after performance of this procedure, refer to Table 2-13, <i>Pre-dive/Post-dive: HP Flask Charging Procedure</i>. Ensure valves are returned to previous settings prior to continuing this procedure or beginning the next one.</p>
1	Open <b>AIR SUPPLY OUT</b> valve (AHP-V502) as required on all flask rack assemblies.
2	For Configuration 1 only, perform the following:
	<div style="border: 2px solid black; padding: 10px; margin: 10px auto; width: 80%;"> <p style="text-align: center;"><b>WARNINGS</b></p> <p><b>Do not fill the fuel tank while it is mounted on the diesel-compressor assembly. The fuel tank shall be disconnected and moved away from the immediate vicinity of the diving equipment prior to refueling. Failure to observe this warning could result in a fuel spill, creating an immediate fire hazard and possibly causing contamination of the diving equipment, all of which could result in injury or death to personnel and damage to the equipment.</b></p> <p><b>The LWDS is designed to operate in ambient temperatures of 40°-100°F. When operating in temperatures below 40°F, the diesel-compressor assembly requires the use of special fuels and lubricants. Failure to use the prescribed diesel fuel and lubricating oils could result in injury or death to divers or support personnel and damage to the equipment.</b></p> </div> <div style="border: 1px solid black; padding: 10px; margin: 10px auto; width: 80%;"> <p style="text-align: center;"><b>CAUTION</b></p> <p>Use diesel fuel only. Ensure fuel tank vent is open.</p> </div>

## SS500-HK-MMO-010

Table 2-12. Modified Start-Up Procedure—Continued

Step	Procedure
	<div style="border: 1px solid black; padding: 10px; text-align: center;"> <p><b>CAUTION</b></p> <p>Fuel contamination can cause damage to the fuel injection system resulting in engine failure.</p> </div>
	a. Check fuel level in diesel engine. Refuel as required (see Figure 2-17 for approved fuel).
	b. Prime diesel engine fuel line using primer bulb (squeeze 8-10 times).
	c. Check oil level on diesel engine dipstick. Add oil as required (see Figure 2-17 for approved oils); do not overfill.
	d. Check oil level in compressor sight glass. Add oil as required (see Figure 2-17 for approved oils). Fill to red dot; do not overfill.
	e. Ensure <b>LP AIR OUT</b> valve (ALP-V401) is closed fully CW.
	f. Ensure pilot valve (ALP-V403) is in unloaded (upright) position.
	g. Ensure engine decompressor lever is in <b>START</b> position (toward flywheel).
	<div style="border: 1px solid black; padding: 10px; text-align: center;"> <p><b>WARNING</b></p> <p>Allowing starter handle to rotate on the running shaft is dangerous and could result in injury or death to personnel.</p> </div> <div style="border: 1px solid black; padding: 10px; text-align: center; margin-top: 10px;"> <p><b>CAUTION</b></p> <p>Never stop the diesel engine with the decompressors. Failure to comply with this caution may result in valve damage to engine.</p> </div>
	h. Crank start diesel engine and pull engine decompressor lever to <b>RUN</b> position. Run for 3 to 5 minutes in the unloaded (upright) position.
	i. Push pilot valve (ALP-V403) to horizontal position to load compressor.
	j. Read pressure on <b>SUPPLY PRESSURE</b> gauge (ALP-G406) and record on OP-2M in Appendix A; reading should be 140 to 170 psig.
	k. Open <b>LP AIR OUT</b> valve (ALP-V401) fully CCW.
3	<b>Configurations 2 and 3 only:</b> Load volume tank manual adjust regulator (AHP-V201) in accordance with minimum manifold pressure.
4	Open volume tank <b>LP AIR OUT</b> valve (ALP-V210) fully CCW.
5	Load control console manual adjust regulator (AHP-V307) in accordance with minimum manifold pressure.
6	Switch control console <b>SUPPLY SELECTOR</b> valve (ALP-V302) to <b>SECONDARY SUPPLY</b> .

SS500-HK-MMO-010

**Table 2-12. Modified Start-Up Procedure—Continued**

Step	Procedure
	<p style="text-align: center;"><b>WARNING</b></p> <p>For the following step, maintain a firm grip on the hose and point the free end away from personnel to avoid injury from flying debris.</p>
7	Slowly open control console <b>DIVER AIR</b> valves (ALP-V304, ALP-V305, and ALP-V306) CCW to purge hoses. Close valves fully CW.
8	Switch control console <b>SUPPLY SELECTOR</b> valve (ALP-V302) to <b>PRIMARY SUPPLY</b> .
	<p style="text-align: center;"><b>WARNING</b></p> <p>For the following step, maintain a firm grip on the hose and point the free end away from personnel to avoid injury from flying debris.</p>
9	Slowly open control console <b>DIVER AIR</b> valves (ALP-V304, ALP-V305, and ALP-V306) CCW to purge hoses. Close valves fully CW.
	<p style="text-align: center;"><b>NOTE</b></p> <p>Proceed to Table 2-14, <i>Pre-dive Start-Up: Diver Equipment</i>.</p>



THIS PAGE INTENTIONALLY LEFT BLANK

## SS500-HK-MMO-010

**2.3.7 PREDIVE/POSTDIVE: HP FLASK CHARGING PROCEDURE.** The procedure in Table 2-13 contains a detailed description of the steps required to charge the HP flasks immediately prior to or following the actual dive. OP-3 in Appendix A contains a corresponding operational checklist that may be photocopied for use during this procedure.

**Table 2-13. Pre-dive/Post-dive: HP Flask Charging Procedure**

Step	Procedure
	<p style="text-align: center;"><b>NOTES</b></p> <p>Record notes and deficiencies in section provided at the end of OP-3 in Appendix A.</p> <p>The following flask charging procedure applies to all configurations. Flask racks should be charged only as required.</p> <p>The flask charging procedure involves the following LWDS equipment, as required: Configuration 1—1 secondary flask rack assembly and 1 roof rack assembly; Configuration 2—1 secondary flask rack assembly, minimum of 3 primary flask rack assemblies, and 1 roof rack assembly; Configuration 3—minimum of 2 secondary and 3 primary flask rack assemblies, and 1 roof rack assembly</p> <p>If charging without a roof rack assembly, ensure charging whip has a relief valve set at 3,300 psig.</p> <p>Perform pre-steps A thru C only if secondary flask rack in Configuration 2 requires charging; otherwise, proceed to step 1.</p>
A	Ensure primary HP deck hose (H-102) is depressurized and disconnect from <b>AIR SUPPLY OUT</b> valve (AHP-V502) on lowest primary flask rack assembly (first stack, bottom rack in multiple stack configurations). Cap hose.
B	Loosen flask whip at secondary flask rack <b>AIR SUPPLY NEXT RACK</b> valve (AHP-V501). Remove bag from free end of whip and connect whip to lowest primary flask rack <b>AIR SUPPLY OUT</b> valve (AHP-V502). Tighten connectors.
C	Ensure secondary HP deck hose (H-102) is depressurized and disconnect from secondary flask rack <b>AIR SUPPLY OUT</b> valve (AHP-V502). Cap valve and hose.
	<p style="text-align: center;"><b>NOTES</b></p> <p>Ensure all HP flasks and components have valid hydrostatic test dates.</p> <p>Perform the following procedure only on the racks that are to be charged.</p>
1	Ensure all primary and secondary flask rack valves (AHP-V501, AHP-V502, AHP-V503, AHP-V504, AHP-V505, AHP-V506, and AHP-V507) are closed (turned fully CW).

## SS500-HK-MMO-010

Table 2-13. Pre-dive/Post-dive: HP Flask Charging Procedure—Continued

Step	Procedure
	<p style="text-align: center;"><b>NOTE</b></p> <p>Ensure flask whips are connected between racks in accordance with the following:</p> <ul style="list-style-type: none"> <li>● Table 2-7, Part II, Step 11 for secondary air in Configuration 1</li> <li>● Table 2-7, Part V for primary air in Configurations 2 and 3</li> <li>● Table 2-7, Part VI and Table 2-13, pre-steps A thru C for secondary air in Configuration 2</li> <li>● Table 2-7, Part VII for secondary air in Configuration 3</li> </ul> <p>For multiple stacks only: Ensure stacks are interconnected with deck hose (H-105) in accordance with Table 2-7, Part V, Step 2.</p>
2	Open all primary and secondary flask rack <b>GAUGE ISOLATION</b> valves (AHP-V503) fully CCW; back off CW 1/4 turn.
3	Open roof rack <b>GAUGE ISOLATION</b> valve (AHP-V601) fully CCW; back off CW 1/4 turn.
	<div style="border: 2px solid black; padding: 10px; text-align: center;"> <p><b>WARNINGS</b></p> <p><b>Use only Authorized for Navy Use (ANU) approved HP compressors with moisture separators and filtration for charging LWDS HP air flasks. Refer to <i>Diving Equipment Authorized for U.S. Navy Use (ANU)</i> list for approved HP compressors.</b></p> <p><b>Always connect a safety cable with the HP charging line from the charging station to the flask rack frame when charging. Failure to comply with this warning may cause injury or death to personnel.</b></p> </div>
4	Connect HP air supply hose to HP compressor; use adapters as required. Secure safety cable to compressor frame.
5	Connect free end of the compressor HP air supply hose to roof rack assembly <b>AHP CHARGING</b> bulkhead connector and secure safety cable to top rack lifting handle. Use adapters as required.
6	Start and run HP compressor at normal operating condition in accordance with the appropriate technical manual.
7	Pressurize HP air supply hose and check for leaks.
8	Slowly open roof rack charge inlet valve (AHP-V604) until fully CCW.
9	Open primary/secondary flask rack valves (AHP-V501, AHP-V504, AHP-V505, AHP-V506, and AHP-V507) fully CCW; back off CW 1/4 turn.

## SS500-HK-MMO-010

Table 2-13. Prediver/Postdiver: HP Flask Charging Procedure—Continued

Step	Procedure
	<p style="text-align: center;"><b>NOTE</b></p> <p>Do not open <b>AIR SUPPLY OUT</b> valve (AHP-V502) if whip is not attached to <b>AIR SUPPLY NEXT RACK</b> valve (AHP-V501) of another primary or secondary flask rack assembly.</p>
10	On all except lowest rack in charging loop, open primary/secondary flask rack <b>AIR SUPPLY OUT</b> valves (AHP-V502) fully CCW; back off CW 1/4 turn.
11	Charge primary/secondary flask rack assemblies to 3,000 psig (maximum).
12	Close primary/secondary flask shutoff valves (AHP-V505, AHP-V506, and AHP-V507) fully CW.
13	Secure HP compressor in accordance with the appropriate technical manual.
14	Lowest rack only: Open <b>AIR SUPPLY OUT</b> valve (AHP-V502). Bleed manifolds and hoses. Close valve fully CW.
15	Disconnect compressor HP air supply hose from compressor and from roof rack <b>AHP CHARGING</b> bulkhead connector. Cap bulkhead connector.
16	Close (or ensure closed) all primary/secondary flask rack and roof rack valves (AHP-V501, AHP-V502, AHP-V503, AHP-V504, AHP-V505, AHP-V506, AHP-V507, AHP-V601, and AHP-V604) fully CW.
	<p style="text-align: center;"><b>NOTE</b></p> <p>The following step may be omitted if flasks have been charged with a compressor package using any of the air purification systems found on the ANU list, section 6.1, or any HP air source that provides air at a dew point of -50°F or lower.</p>
17	<p>Unstack racks as required and drain moisture from flasks as follows:</p> <ol style="list-style-type: none"> <li>a. Open flask rack <b>GAUGE ISOLATION</b> valve (AHP-V503) and <b>AIR SUPPLY THIS RACK</b> valve (AHP-V504). Verify <b>MANIFOLD PRESSURE</b> gauge AHP-G508 reads 0 psig; if not, vent pressure from system. Close AHP-V503 and AHP-V504.</li> <li>b. Disconnect flask whips from flask valve connectors.</li> <li>c. With the valve end pointing down, tilt rack approximately 30 degrees (minimum).</li> <li>d. Slowly open each flask shutoff valve. Drain moisture from flasks and close valves.</li> <li>e. Repeat steps a thru d for remaining racks. Reposition racks and reconnect flask whips.</li> <li>f. Return equipment to readiness condition.</li> </ol>
18	Reinstall dust caps over connectors and fittings.

## SS500-HK-MMO-010

**Table 2-13. Pre-dive/Post-dive: HP Flask Charging Procedure—Continued**

Step	Procedure
	<p style="text-align: center;"><b>NOTE</b></p> <p>Perform post-steps D thru F only if pre-steps A thru C were performed at the beginning of this procedure.</p>
D	Uncap secondary flask rack <b>AIR SUPPLY OUT</b> valve (AHP-V502) and secondary HP deck hose (H-102). Connect H-102 to AHP-V502.
E	Loosen flask whip at secondary flask rack <b>AIR SUPPLY NEXT RACK</b> valve (AHP-V501) and disconnect flask whip from lowest primary flask rack <b>AIR SUPPLY OUT</b> valve (AHP-V502). Tighten connector at AHP-V501 and bag free end of whip.
F	Uncap primary HP deck hose (H-102) and connect to <b>AIR SUPPLY OUT</b> valve (AHP-V502) on lowest primary flask rack assembly (first stack, bottom rack in multiple stack configurations).
	<p style="text-align: center;"><b>NOTES</b></p> <p>To continue pre-dive start-up procedures, return to Table 2-9, 2-10, 2-11, or 2-12 as appropriate. If pre-dive start-up for air supplies is complete, proceed to Table 2-14, <i>Pre-dive Start-Up: Diver Equipment</i>.</p> <p>To continue post-dive shutdown or modified shutdown procedures, return to Table 2-16 or 2-17, respectively. If post-dive operations are complete, proceed to Table 2-18, <i>Post-mission Procedures: Configurations 1, 2, and 3</i>.</p>

## SS500-HK-MMO-010

**2.3.8 PREDIVE START-UP: DIVER EQUIPMENT.** The procedure in Table 2-14 contains a detailed description of the steps necessary to start up the diver equipment in all three configurations. Appendix A contains a corresponding operational checklist (OP-4) that may be photocopied for use during this phase of the predive start-up.

**Table 2-14. Predive Start-Up: Diver Equipment**

Step	Procedure
	<p style="text-align: center;"><b>NOTE</b></p> <p>Record notes and deficiencies in section provided at the end of OP-4 in Appendix A.</p>
1	Connect diver umbilicals to <b>DIVER AIR</b> and <b>DIVER DEPTH</b> bulkhead connectors on back of control console assembly.
2	Switch control console <b>SUPPLY SELECTOR</b> valve (ALP-V302) to <b>PRIMARY SUPPLY</b> .
	<p style="text-align: center;"><b>WARNING</b></p> <p style="text-align: center;"><b>For the following step, maintain a firm grip on the hose and point the free end away from personnel to avoid injury from flying debris.</b></p>
3	Slowly open control console <b>DIVER AIR</b> and <b>DIVER DEPTH</b> valves (ALP-V304, ALP-V305, ALP-V306, ALP-V312, ALP-V313, and ALP-V314) CCW to purge hoses. Close valves fully CW.
4	Connect diver umbilicals to Underwater Breathing Apparatuses (UBAs); complete UBA premission and predive checklists.
	<p style="text-align: center;"><b>NOTES</b></p> <p>Commence dive in accordance with unit dive plan and Standard Operating Procedures per the <i>U.S. Navy Diving Manual</i>, NAVSEA SS521-AG-PRO-010.</p> <p>If primary supply pressure drops below minimum manifold pressure during the dive, proceed immediately to Table 2-19, <i>Emergency Procedure: Loss of Primary Air</i>.</p> <p>If flasks require charging during the dive, refer to Table 2-15, <i>During OPs: HP Flask Charging Procedure</i>.</p> <p>Upon completion of the dive, proceed to the appropriate shutdown procedure in Table 2-16 or 2-17.</p>

THIS PAGE INTENTIONALLY LEFT BLANK

## SS500-HK-MMO-010

**2.3.9 DURING OPS: HP FLASK CHARGING PROCEDURE.** The procedure in Table 2-15 contains a detailed description of the steps necessary to charge the primary HP air flask rack assemblies during diving operations using the LWDS in Configuration 2 or 3. Appendix A contains a corresponding operational checklist (OP-5) that may be photocopied for use during the HP flask charging procedure.

**Table 2-15. During OPs: HP Flask Charging Procedure**

Step	Procedure
	<p style="text-align: center;"><b>NOTE</b></p> <p>Record notes and deficiencies in section provided at the end of OP-5 in Appendix A.</p> <div style="border: 1px solid black; padding: 10px; margin: 10px auto; width: 80%;"> <p style="text-align: center;"><b>WARNINGS</b></p> <p><b>Use only Authorized for Navy Use (ANU) approved HP compressors with moisture separators and filtration for charging LWDS HP air flasks. Refer to <i>Diving Equipment Authorized for U.S. Navy Use (ANU)</i> list for approved HP compressors.</b></p> <p><b>Always connect a safety cable with the HP charging line from the charging station to the flask rack frame when charging. Failure to comply with this warning may cause injury or death to personnel.</b></p> </div>
1	Connect compressor HP air supply hose to roof rack <b>AHP CHARGING</b> bulkhead connector and secure safety cable to top rack lifting handle. Use adapters as required.
2	Connect HP air supply hose to HP compressor outlet connector; use adapters as required. Secure safety cable to compressor frame.
3	Start and run HP compressor at normal operating condition in accordance with the appropriate technical manual.
	<div style="border: 1px solid black; padding: 10px; margin: 10px auto; width: 80%;"> <p style="text-align: center;"><b>WARNING</b></p> <p><b>Never charge the lowest primary flask rack assembly in the breathing loop during a dive. Failure to comply with this warning may cause injury or death to divers.</b></p> </div>
4	On lowest rack to be charged, close <b>AIR SUPPLY OUT</b> valve (AHP-V502) fully CW.
5	Pressurize HP air supply hose and check for leaks.
6	Slowly open roof rack charge inlet valve (AHP-V604) until fully CCW; back off CW 1/4 turn.
7	Charge flask rack assemblies (as required) to 3,000 psig (maximum).



## SS500-HK-MMO-010

**Table 2-15. During OPs: HP Flask Charging Procedure—Continued**

<b>Step</b>	<b>Procedure</b>
8	Close roof rack charge inlet valve (AHP-V604) fully CW.
9	Shut down HP compressor.
10	Open the <b>AIR SUPPLY OUT</b> valve (AHP-V502) closed in step 4. Opening valve will cause racks to cascade.
	<p><b>NOTE</b></p> <p>Repeat steps 3 thru 10 as necessary for continued diving operations.</p>
11	If end of mission, disconnect air supply hose from HP compressor and roof rack <b>AHP CHARGING</b> bulkhead connector. Cap and bag ends of hose; cap bulkhead connectors. Secure HP compressor.

## SS500-HK-MMO-010

**2.3.10 POSTDIVE SHUTDOWN PROCEDURES: CONFIGURATIONS 1, 2, AND 3.** The procedures in Table 2-16 contain a detailed description of the steps required to shut down operations in all configurations. These procedures are to be performed after every dive unless diving operations are expected to continue within 24 hours, in which case the modified shutdown procedure in Table 2-17 may be used instead. The only other exception to using these procedures applies to the last dive of the mission, in which case the postmission procedures in Table 2-18 should be performed. OP-6 in Appendix A contains a corresponding checklist that may be photocopied for use during the following postdive shutdown procedures.

**Table 2-16. Postdive Shutdown Procedures: Configurations 1, 2, and 3**

Step	Procedure
	<p style="text-align: center;"><b>NOTE</b></p> <p>Record notes and deficiencies in section provided at the end of OP-6 in Appendix A.</p> <p>If diving supervisor determines that flasks need to be charged before or during performance of this procedure, refer to Table 2-13, <i>Pre-dive/Post-dive: HP Flask Charging Procedure</i>. Ensure that valves are returned to previous settings prior to continuing this procedure or beginning the next procedure.</p>
<b>PART I - POSTDIVE SHUTDOWN PROCEDURES FOR CONFIGURATION 1</b>	
	<div style="border: 1px solid black; padding: 10px; text-align: center;"> <p><b>CAUTION</b></p> <p>Never stop the diesel engine with the decompressors. Failure to comply with this caution may result in valve damage to engine.</p> </div>
1	Pull up stop/run cable to stop diesel engine.
	<div style="border: 1px solid black; padding: 10px; text-align: center;"> <p><b>WARNING</b></p> <p><b>Do not fill the fuel tank while it is mounted on the diesel-compressor assembly. The fuel tank shall be disconnected and moved away from the immediate vicinity of the diving equipment prior to refueling. Failure to observe this warning could result in a fuel spill, creating an immediate fire hazard and possibly causing contamination of the diving equipment, all of which could result in injury or death to personnel and damage to the equipment.</b></p> </div>

## SS500-HK-MMO-010

Table 2-16. Postdive Shutdown Procedures: Configurations 1, 2, and 3—Cont.

Step	Procedure
<b>PART I - POSTDIVE SHUTDOWN PROCEDURES FOR CONFIGURATION 1—Continued</b>	
	<div style="border: 1px solid black; padding: 10px; margin: 10px auto; width: 80%;"> <p style="text-align: center;"><b>WARNING</b></p> <p>The LWDS is designed to operate in ambient temperatures of 40°-100°F. When operating in temperatures below 40°F, the diesel-compressor assembly requires the use of special fuels and lubricants. Failure to use the prescribed diesel fuel and lubricating oils could result in injury or death to divers or support personnel and damage to the equipment.</p> </div> <div style="border: 1px solid black; padding: 10px; margin: 10px auto; width: 80%;"> <p style="text-align: center;"><b>CAUTIONS</b></p> <p style="text-align: center;">Use diesel fuel only. Ensure fuel tank vent is open.</p> <p>Fuel contamination can cause damage to the fuel injection system resulting in engine failure.</p> </div>
2	Check fuel level in diesel engine. Refuel as required (see Figure 2-17 for approved fuel).
3	Check oil level on diesel engine dipstick. Add oil as required (see Figure 2-17 for approved oils); do not overfill.
4	Check oil level in compressor sight glass. Add oil as required (see Figure 2-17 for approved oils). Fill to red dot; do not overfill.
5	Close control console <b>DIVER DEPTH</b> valves (ALP-V312, ALP-V313, and ALP-314) fully CW.
6	Close flask shutoff valves (AHP-V505, AHP-V506, and AHP-V507) fully CW.
7	Switch control console <b>SUPPLY SELECTOR</b> valve (ALP-V302) to <b>SECONDARY SUPPLY</b> .
	<div style="border: 1px solid black; padding: 10px; margin: 10px auto; width: 80%;"> <p style="text-align: center;"><b>WARNING</b></p> <p>Before bleeding HP air, ensure all personnel are clear of area to avoid injury from flying debris. Operator must wear protective eye wear when bleeding system.</p> </div>
8	Push UBA purge button on UBA face mask to bleed secondary HP portion of system.
9	Turn control console manual adjust regulator (AHP-V307) CCW to unload.

## SS500-HK-MMO-010

Table 2-16. Postdive Shutdown Procedures: Configurations 1, 2, and 3—Cont.

Step	Procedure		
<b>PART I - POSTDIVE SHUTDOWN PROCEDURES FOR CONFIGURATION 1—Continued</b>			
10	Switch control console <b>SUPPLY SELECTOR</b> valve (ALP-V302) to <b>PRIMARY SUPPLY</b> .		
11	Close volume tank <b>LP AIR OUT</b> valve (ALP-V210) fully CW.		
	<p><b>WARNING</b></p> <p><b>Before bleeding LP air, ensure all personnel are clear of area to avoid injury from flying debris. Operator must wear protective eye wear when bleeding system.</b></p>		
12	Push UBA purge button on UBA face mask to bleed primary LP portion of system.		
13	Close control console <b>DIVER AIR</b> valves (ALP-V304, ALP-V305, and ALP-V306) fully CW.		
14	Switch control console <b>SUPPLY SELECTOR</b> valve (ALP-V302) to <b>CLOSE</b> .		
15	Open compressor moisture separator (ALP-V402), volume tank inlet pre-filter (ALP-V205), volume tank outlet final filter (ALP-V209), and volume tank drain valve (ALP-V208) fully CCW to drain moisture from system; close fully CW.		
16	<p>Ensure the following valves are closed or unloaded:</p> <table border="0" style="width: 100%;"> <tr> <td style="vertical-align: top;"> <p><b><u>Volume Tank Assembly</u></b></p> <p>Regulator . . . . . AHP-V201</p> <p>Gauge Isolation . . . . . AHP-V202</p> <p>Gauge Isolation . . . . . ALP-V204</p> <p>LP Air Out . . . . . ALP-V210</p> <p><b><u>Control Console Assembly</u></b></p> <p>Gauge Isolation . . . . . ALP-V301</p> <p>Supply Selector . . . . . ALP-V302</p> <p>Diver Air (Red) . . . . . ALP-V304</p> <p>Diver Air (Green) . . . . . ALP-V305</p> <p>Diver Air (Yellow) . . . . . ALP-V306</p> <p>Regulator . . . . . AHP-V307</p> <p>Gauge Isolation . . . . . AHP-V309</p> <p>Gauge Isolation . . . . . ALP-V310</p> <p>Diver Depth (Red) . . . . . ALP-V312</p> </td> <td style="vertical-align: top;"> <p><b><u>Control Console Assembly—Continued</u></b></p> <p>Diver Depth (Green) . . . . . ALP-V313</p> <p>Diver Depth (Yellow) . . . . . ALP-V314</p> <p><b><u>Diesel-Compressor Assembly</u></b></p> <p>LP Air Out . . . . . ALP-V401</p> <p>Drain Valve . . . . . ALP-V402</p> <p>Gauge Isolation . . . . . ALP-V405</p> <p><b><u>Flask Rack Assembly</u></b></p> <p>Air Supply Next Rack . . . . . AHP-V501</p> <p>Air Supply Out . . . . . AHP-V502</p> <p>Gauge Isolation . . . . . AHP-V503</p> <p>Air Supply This Rack . . . . . AHP-V504</p> <p><b><u>Roof Rack Assembly</u></b></p> <p>Gauge Isolation . . . . . AHP-V601</p> <p>Charge Inlet . . . . . AHP-V604</p> </td> </tr> </table>	<p><b><u>Volume Tank Assembly</u></b></p> <p>Regulator . . . . . AHP-V201</p> <p>Gauge Isolation . . . . . AHP-V202</p> <p>Gauge Isolation . . . . . ALP-V204</p> <p>LP Air Out . . . . . ALP-V210</p> <p><b><u>Control Console Assembly</u></b></p> <p>Gauge Isolation . . . . . ALP-V301</p> <p>Supply Selector . . . . . ALP-V302</p> <p>Diver Air (Red) . . . . . ALP-V304</p> <p>Diver Air (Green) . . . . . ALP-V305</p> <p>Diver Air (Yellow) . . . . . ALP-V306</p> <p>Regulator . . . . . AHP-V307</p> <p>Gauge Isolation . . . . . AHP-V309</p> <p>Gauge Isolation . . . . . ALP-V310</p> <p>Diver Depth (Red) . . . . . ALP-V312</p>	<p><b><u>Control Console Assembly—Continued</u></b></p> <p>Diver Depth (Green) . . . . . ALP-V313</p> <p>Diver Depth (Yellow) . . . . . ALP-V314</p> <p><b><u>Diesel-Compressor Assembly</u></b></p> <p>LP Air Out . . . . . ALP-V401</p> <p>Drain Valve . . . . . ALP-V402</p> <p>Gauge Isolation . . . . . ALP-V405</p> <p><b><u>Flask Rack Assembly</u></b></p> <p>Air Supply Next Rack . . . . . AHP-V501</p> <p>Air Supply Out . . . . . AHP-V502</p> <p>Gauge Isolation . . . . . AHP-V503</p> <p>Air Supply This Rack . . . . . AHP-V504</p> <p><b><u>Roof Rack Assembly</u></b></p> <p>Gauge Isolation . . . . . AHP-V601</p> <p>Charge Inlet . . . . . AHP-V604</p>
<p><b><u>Volume Tank Assembly</u></b></p> <p>Regulator . . . . . AHP-V201</p> <p>Gauge Isolation . . . . . AHP-V202</p> <p>Gauge Isolation . . . . . ALP-V204</p> <p>LP Air Out . . . . . ALP-V210</p> <p><b><u>Control Console Assembly</u></b></p> <p>Gauge Isolation . . . . . ALP-V301</p> <p>Supply Selector . . . . . ALP-V302</p> <p>Diver Air (Red) . . . . . ALP-V304</p> <p>Diver Air (Green) . . . . . ALP-V305</p> <p>Diver Air (Yellow) . . . . . ALP-V306</p> <p>Regulator . . . . . AHP-V307</p> <p>Gauge Isolation . . . . . AHP-V309</p> <p>Gauge Isolation . . . . . ALP-V310</p> <p>Diver Depth (Red) . . . . . ALP-V312</p>	<p><b><u>Control Console Assembly—Continued</u></b></p> <p>Diver Depth (Green) . . . . . ALP-V313</p> <p>Diver Depth (Yellow) . . . . . ALP-V314</p> <p><b><u>Diesel-Compressor Assembly</u></b></p> <p>LP Air Out . . . . . ALP-V401</p> <p>Drain Valve . . . . . ALP-V402</p> <p>Gauge Isolation . . . . . ALP-V405</p> <p><b><u>Flask Rack Assembly</u></b></p> <p>Air Supply Next Rack . . . . . AHP-V501</p> <p>Air Supply Out . . . . . AHP-V502</p> <p>Gauge Isolation . . . . . AHP-V503</p> <p>Air Supply This Rack . . . . . AHP-V504</p> <p><b><u>Roof Rack Assembly</u></b></p> <p>Gauge Isolation . . . . . AHP-V601</p> <p>Charge Inlet . . . . . AHP-V604</p>		
	<p><b>NOTE</b></p> <p>If the dive mission is complete, proceed to Table 2-18, <i>Postmission Procedures: Configurations 1, 2, and 3</i>. If the dive mission is not complete, perform all required steps in Tables 2-8 and 2-9 before proceeding to Table 2-14, <i>Pre-dive Start-Up: Diver Equipment</i>.</p>		

## SS500-HK-MMO-010

Table 2-16. Postdive Shutdown Procedures: Configurations 1, 2, and 3—Cont.

Step	Procedure		
<b>PART II - POSTDIVE SHUTDOWN PROCEDURES FOR CONFIGURATIONS 2 AND 3</b>			
1	Close control console <b>DIVER DEPTH</b> valves (ALP-V312, ALP-V313, ALP-V314) fully CW.		
2	Close all primary and secondary flask rack flask shutoff valves (AHP-V505, AHP-V506, and AHP-V507) fully CW.		
3	Switch control console <b>SUPPLY SELECTOR</b> valve (ALP-V302) to <b>SECONDARY SUPPLY</b> .		
	<p><b>WARNING</b></p> <p>Before bleeding HP air, ensure all personnel are clear of area to avoid injury from flying debris. Operator must wear protective eye wear when bleeding system.</p>		
4	Push UBA purge button on the UBA face mask to bleed secondary HP portion of system.		
5	Turn control console manual adjust regulator (AHP-V307) CCW to unload.		
6	Switch control console <b>SUPPLY SELECTOR</b> valve (ALP-V302) to <b>PRIMARY SUPPLY</b> .		
7	Close volume tank <b>LP AIR OUT</b> valve (ALP-V210) fully CW.		
	<p><b>WARNING</b></p> <p>Before bleeding LP air, ensure all personnel are clear of area to avoid injury from flying debris. Operator must wear protective eye wear when bleeding system.</p>		
8	Push UBA purge button on UBA face mask to bleed primary LP portion of system.		
9	Close control console <b>DIVER AIR</b> valves (ALP-V304, ALP-V305, and ALP-V306) fully CW.		
10	Switch control console <b>SUPPLY SELECTOR</b> valve (ALP-V302) to <b>CLOSE</b> .		
11	On the volume tank assembly, open pre-filter condensate drain valve (ALP-V205), volume tank drain valve (ALP-V208), and final filter condensate drain valve (ALP-V209) to bleed moisture from LP system. Close valves.		
12	Ensure the following valves are closed or unloaded:		
	<table style="width: 100%; border: none;"> <tr> <td style="width: 50%; vertical-align: top;"> <p><b>Volume Tank Assembly</b></p> <p>Regulator . . . . . AHP-V201</p> <p>Gauge Isolation . . . . . AHP-V202</p> <p>Gauge Isolation . . . . . ALP-V204</p> <p>LP Air Out . . . . . ALP-V210</p> <p><b>Control Console Assembly</b></p> <p>Gauge Isolation . . . . . ALP-V301</p> <p>Supply Selector . . . . . ALP-V302</p> <p>Diver Air (Red) . . . . . ALP-V304</p> </td> <td style="width: 50%; vertical-align: top;"> <p><b>Control Console Assembly—Continued</b></p> <p>Diver Air (Green) . . . . . ALP-V305</p> <p>Diver Air (Yellow) . . . . . ALP-V306</p> <p>Regulator . . . . . AHP-V307</p> <p>Gauge Isolation . . . . . AHP-V309</p> <p>Gauge Isolation . . . . . ALP-V310</p> <p>Diver Depth (Red) . . . . . ALP-V312</p> <p>Diver Depth (Green) . . . . . ALP-V313</p> <p>Diver Depth (Yellow) . . . . . ALP-V314</p> </td> </tr> </table>	<p><b>Volume Tank Assembly</b></p> <p>Regulator . . . . . AHP-V201</p> <p>Gauge Isolation . . . . . AHP-V202</p> <p>Gauge Isolation . . . . . ALP-V204</p> <p>LP Air Out . . . . . ALP-V210</p> <p><b>Control Console Assembly</b></p> <p>Gauge Isolation . . . . . ALP-V301</p> <p>Supply Selector . . . . . ALP-V302</p> <p>Diver Air (Red) . . . . . ALP-V304</p>	<p><b>Control Console Assembly—Continued</b></p> <p>Diver Air (Green) . . . . . ALP-V305</p> <p>Diver Air (Yellow) . . . . . ALP-V306</p> <p>Regulator . . . . . AHP-V307</p> <p>Gauge Isolation . . . . . AHP-V309</p> <p>Gauge Isolation . . . . . ALP-V310</p> <p>Diver Depth (Red) . . . . . ALP-V312</p> <p>Diver Depth (Green) . . . . . ALP-V313</p> <p>Diver Depth (Yellow) . . . . . ALP-V314</p>
<p><b>Volume Tank Assembly</b></p> <p>Regulator . . . . . AHP-V201</p> <p>Gauge Isolation . . . . . AHP-V202</p> <p>Gauge Isolation . . . . . ALP-V204</p> <p>LP Air Out . . . . . ALP-V210</p> <p><b>Control Console Assembly</b></p> <p>Gauge Isolation . . . . . ALP-V301</p> <p>Supply Selector . . . . . ALP-V302</p> <p>Diver Air (Red) . . . . . ALP-V304</p>	<p><b>Control Console Assembly—Continued</b></p> <p>Diver Air (Green) . . . . . ALP-V305</p> <p>Diver Air (Yellow) . . . . . ALP-V306</p> <p>Regulator . . . . . AHP-V307</p> <p>Gauge Isolation . . . . . AHP-V309</p> <p>Gauge Isolation . . . . . ALP-V310</p> <p>Diver Depth (Red) . . . . . ALP-V312</p> <p>Diver Depth (Green) . . . . . ALP-V313</p> <p>Diver Depth (Yellow) . . . . . ALP-V314</p>		

## SS500-HK-MMO-010

Table 2-16. Postdive Shutdown Procedures: Configurations 1, 2, and 3—Cont.

Step	Procedure																				
<b>PART II - POSTDIVE SHUTDOWN PROCEDURES FOR CONFIGURATIONS 2 AND 3—Cont.</b>																					
12 Cont	<p>Ensure the following valves are closed or unloaded:</p> <table border="0" data-bbox="305 457 1429 625"> <tr> <td colspan="2"><b>Flask Rack Assemblies</b></td> <td colspan="2"><b>Roof Rack Assembly</b></td> </tr> <tr> <td>Air Supply Next Rack . . . . .</td> <td>AHP-V501</td> <td>Gauge Isolation . . . . .</td> <td>AHP-V601</td> </tr> <tr> <td>Air Supply Out . . . . .</td> <td>AHP-V502</td> <td>Charge Inlet . . . . .</td> <td>AHP-V604</td> </tr> <tr> <td>Gauge Isolation . . . . .</td> <td>AHP-V503</td> <td></td> <td></td> </tr> <tr> <td>Air Supply This Rack . . . . .</td> <td>AHP-V504</td> <td></td> <td></td> </tr> </table>	<b>Flask Rack Assemblies</b>		<b>Roof Rack Assembly</b>		Air Supply Next Rack . . . . .	AHP-V501	Gauge Isolation . . . . .	AHP-V601	Air Supply Out . . . . .	AHP-V502	Charge Inlet . . . . .	AHP-V604	Gauge Isolation . . . . .	AHP-V503			Air Supply This Rack . . . . .	AHP-V504		
<b>Flask Rack Assemblies</b>		<b>Roof Rack Assembly</b>																			
Air Supply Next Rack . . . . .	AHP-V501	Gauge Isolation . . . . .	AHP-V601																		
Air Supply Out . . . . .	AHP-V502	Charge Inlet . . . . .	AHP-V604																		
Gauge Isolation . . . . .	AHP-V503																				
Air Supply This Rack . . . . .	AHP-V504																				
<p style="text-align: center;"><b>NOTE</b></p> <p>The following step may be omitted if flasks have been charged with a compressor package using any of the air purification systems found on the ANU list, section 6.1, or any HP air source that provides air at a dew point of -50°F or lower.</p>																					
13	<p>If flasks were charged during diving operations, unstack racks as required and drain moisture from flasks as follows:</p> <ol style="list-style-type: none"> <li>a. Open flask rack <b>GAUGE ISOLATION</b> valve (AHP-V503) and <b>AIR SUPPLY THIS RACK</b> valve (AHP-V504). Verify <b>MANIFOLD PRESSURE</b> gauge AHP-G508 reads 0 psig; if not, vent pressure from system. Close AHP-V503 and AHP-V504.</li> <li>b. Disconnect flask whips from flask valve connectors.</li> <li>c. With the valve end pointing down, tilt rack approximately 30 degrees (minimum).</li> <li>d. Slowly open each flask shutoff valve. Drain moisture from flasks and close valves.</li> <li>e. Repeat steps a thru d for remaining racks. Reposition racks and reconnect flask whips.</li> <li>f. Return equipment to readiness condition.</li> </ol>																				
<p style="text-align: center;"><b>NOTE</b></p> <p>If the dive mission is complete, proceed to Table 2-18, <i>Postmission Procedures: Configurations 1, 2, and 3</i>. If the dive mission is not complete, perform all required steps in Tables 2-10 and 2-11 before proceeding with Table 2-14, <i>Pre-dive Start-Up: Diver Equipment</i>.</p>																					

THIS PAGE INTENTIONALLY LEFT BLANK

## SS500-HK-MMO-010

**2.3.11 MODIFIED SHUTDOWN PROCEDURE: CONFIGURATIONS 1, 2, AND 3.** The procedure in Table 2-17 may be used in place of the postdive shutdown procedures presented in Table 2-16 if the equipment will be used again within 24 hours. If it is anticipated that more than 24 hours will pass before using the equipment again, the shutdown procedures in Table 2-16 must be performed instead. Appendix A contains a corresponding operational checklist (OP-6M) that may be photocopied for use during the modified shutdown procedure.

**Table 2-17. Modified Shutdown Procedure: Configurations 1, 2, and 3**

Step	Procedure
	<p style="text-align: center;"><b>NOTES</b></p> <p>Record notes and deficiencies in section provided at end of OP-6M in Appendix A.</p> <p>If flasks require charging immediately before, during, or after performance of this procedure, refer to Table 2-13, <i>Pre-dive/Post-dive: HP Flask Charging Procedure</i>. Ensure valves are returned to previous settings prior to continuing this procedure or beginning the next one.</p>
1	Close control console <b>DIVER DEPTH</b> valves (ALP-V312, ALP-V313, ALP-V314) fully CW.
2	Close control console <b>DIVER AIR</b> valves (ALP-V304, ALP-V305, ALP-V306) fully CW.
3	Switch control console <b>SUPPLY SELECTOR</b> valve (ALP-V302) to <b>CLOSE</b> .
4	Ensure control console manual adjust regulator (AHP-V307) is fully CCW (unloaded).
5	Close volume tank <b>LP AIR OUT</b> valve (ALP-V210) fully CW.
	<p style="text-align: center;"><b>CAUTION</b></p> <p>Never stop the diesel engine with the decompressors. Failure to comply with this caution may result in valve damage to engine.</p>
6	<p><b>For Configuration 1 only:</b> Ensure that <b>LP AIR OUT</b> valve (ALP-V401) is closed fully CW and that pilot valve (ALP-V403) is in unloaded (upright) position. Pull up stop/run cable to stop diesel engine.</p> <hr/> <p><b>For Configurations 2 and 3 only:</b> Ensure volume tank manual adjust regulator (AHP-V201) is fully CCW (unloaded).</p>
7	Close <b>AIR SUPPLY OUT</b> valve (AHP-V502) as required on all flask rack assemblies.
	<p style="text-align: center;"><b>NOTE</b></p> <p>If the next dive is scheduled to begin within the 24-hour time limit, proceed to Table 2-12, <i>Modified Start-Up Procedure</i>. If, however, more than 24 hours have elapsed since performing the modified shutdown procedure, perform the appropriate postdive shutdown procedure in Table 2-16 and continue the normal sequence of operations from that point.</p>



THIS PAGE INTENTIONALLY LEFT BLANK

## SS500-HK-MMO-010

**2.3.12 POSTMISSION PROCEDURES: CONFIGURATIONS 1, 2, AND 3.** The procedure in Table 2-18 contains a detailed description of the steps required to prepare the LWDS for transport and stowage in all configurations. Appendix A contains a corresponding operational checklist (OP-7) that may be photocopied for use during postmission procedures.

**Table 2-18. Postmission Procedures: Configurations 1, 2, and 3**

Step	Procedure
	<p style="text-align: center;"><b>NOTE</b></p> <p>Record notes and deficiencies in section provided at the end of OP-7 in Appendix A.</p>
<b>PART I - POSTMISSION PROCEDURES FOR CONFIGURATION 1</b>	
	<p style="text-align: center;"><b>NOTE</b></p> <p>Prior to performing Step 1, ensure the procedures described in Table 2-16, Part I - <i>Postdive Shutdown Procedures for Configuration 1</i>, have been conducted.</p>
1	Open volume tank <b>GAUGE ISOLATION</b> valve (ALP-V204) fully CCW.
2	Open volume tank drain valve (ALP-V208) CCW. Bleed volume tank to approximately 50 psig. Close valve fully CW.
3	Open volume tank pre-filter condensate drain valve (ALP-V205) and bleed deck hose (H-104). Close drain valve.
4	Disconnect diver umbilicals from UBAs and from control console <b>DIVER AIR</b> and <b>DIVER DEPTH</b> bulkhead connectors. Cap/bag as required.
5	Close volume tank <b>GAUGE ISOLATION</b> valve (ALP-V204) fully CW.
6	Disconnect deck hoses: <ul style="list-style-type: none"> <li>H-101—volume tank to control console</li> <li>H-102—secondary HP air to control console</li> <li>H-104—diesel-compressor to volume tank</li> </ul> Cap and bag both ends of each hose. Inspect hoses and connectors for damage. Cap off volume tank, control console, and diesel-compressor assembly bulkhead connectors.
7	Remove wheels from snorkel assembly and reinstall on diesel-compressor assembly frame.
8	Disconnect air intake hose from snorkel assembly and compressor. Disassemble snorkel assembly.
9	Remove control console assembly from volume tank assembly frame. Reinstall and secure cover.
10	Break down volume tank assembly tables and reinstall covers. Pin in place.

## SS500-HK-MMO-010

Table 2-18. Postmission Procedures: Configurations 1, 2, and 3—Continued

Step	Procedure
<b>PART I - POSTMISSION PROCEDURES FOR CONFIGURATION 1—Continued</b>	
11	Disconnect flask whip from roof rack <b>AHP OUT</b> bulkhead connector, and loosen connector at secondary flask rack <b>AIR SUPPLY NEXT RACK</b> valve (AHP-V501). Connect free end of whip to secondary flask rack <b>AIR SUPPLY OUT</b> valve (AHP-V502) bulkhead connector. Tighten connectors and cap <b>AHP OUT</b> .
12	Remove roof rack assembly from secondary flask rack assembly.
<p><b>NOTE</b></p> <p>The following step may be omitted if flasks have been charged with a compressor package using any of the air purification systems found on the ANU list, section 6.1, or any HP air source that provides air at a dew point of -50°F or lower.</p>	
13	Drain moisture from flasks in accordance with the following:
	a. Open flask rack <b>GAUGE ISOLATION</b> valve (AHP-V503) and <b>AIR SUPPLY THIS RACK</b> valve (AHP-V504). Verify <b>MANIFOLD PRESSURE</b> gauge AHP-G508 reads 0 psig; if not, vent pressure from system. Close AHP-V503 and AHP-V504.
	b. Disconnect flask whips from flask valve connectors.
	c. With the valve end pointing down, tilt rack approximately 30 degrees (minimum).
	d. Slowly open each flask shutoff valve. Drain moisture from flasks and close valves.
	e. Return rack to its original position, and reconnect flask whips.
	<p><b>NOTE</b></p> <p>Nonionic detergent (NID) solution is prepared by mixing 1 teaspoon of nonionic detergent to 1 gallon of warm, fresh water.</p>
	14 Wash system exterior with NID solution; rinse with fresh water and dry thoroughly.
15	Inspect system for damage. Accomplish applicable Planned Maintenance System (PMS) actions. Stow system.
<b>PART II - POSTMISSION PROCEDURES FOR CONFIGURATIONS 2 AND 3</b>	
<p><b>NOTE</b></p> <p>Prior to performing Step 1, ensure the procedures described in Table 2-16, Part II - <i>Postdive Shutdown Procedures for Configurations 2 and 3</i>, have been conducted.</p>	
1	Open volume tank <b>GAUGE ISOLATION</b> valve (ALP-V204) fully CCW.

## SS500-HK-MMO-010

Table 2-18. Postmission Procedures: Configurations 1, 2, and 3—Continued

Step	Procedure
<b>PART II - POSTMISSION PROCEDURES FOR CONFIGURATIONS 2 AND 3—Continued</b>	
2	Open volume tank drain valve (ALP-V208) CCW. Bleed volume tank to approximately 50 psig. Close valve fully CW.
3	Disconnect diver umbilicals from UBAs and from control console <b>DIVER AIR</b> and <b>DIVER DEPTH</b> bulkhead connectors. Cap/bag as required.
4	Close volume tank <b>GAUGE ISOLATION</b> valve (ALP-V204) fully CW.
5	Ensure volume tank manual adjust regulator (AHP-V201) is fully CCW (unloaded).
6	Open all primary flask rack <b>AIR SUPPLY NEXT RACK</b> valves (AHP-V501) and <b>AIR SUPPLY OUT</b> valves (AHP-V502).
7	Uncap roof rack <b>AHP CHARGING</b> bulkhead connector.
8	Slowly open roof rack charge inlet valve (AHP-V604) until fully CCW; back off CW 1/4 turn. Allow system to bleed down until roof rack assembly pressure gauge (AHP-G602) reads 0 psig.
9	Close roof rack charge inlet valve (AHP-V604) fully CW.
10	Close all primary flask rack <b>AIR SUPPLY NEXT RACK</b> valves (AHP-V501) and <b>AIR SUPPLY OUT</b> valves (AHP-V502) fully CW.
11	Cap roof rack <b>AHP CHARGING</b> bulkhead connector.
12	Disconnect deck hoses: H-101—volume tank to control console H-102—primary HP air to volume tank H-102—secondary HP air to control console H-105—primary HP air to primary HP air (multiple stacks only) Cap or bag both ends of each hose. Inspect hoses and connectors for damage. Cap volume tank and control console assembly bulkhead connectors.
13	Remove control console assembly from volume tank assembly. Install and secure cover.
14	Break down volume tank assembly tables and reinstall covers; pin in place.
15	Disconnect flask whips from all primary flask rack <b>AIR SUPPLY OUT</b> valve (AHP-V502) connectors and roof rack <b>AHP OUT</b> bulkhead connector. Cap <b>AHP OUT</b> .
16	Loosen flask whip connectors at all primary flask rack <b>AIR SUPPLY NEXT RACK</b> valves (AHP-V501). Connect free end of each flask whip to <b>AIR SUPPLY OUT</b> valve (AHP-V502) connector on the same rack. Tighten both connectors.
17	If only one secondary flask rack assembly is used: Unbag/uncap flask whip connected to <b>AIR SUPPLY NEXT RACK</b> valve (AHP-V501). Loosen AHP-V501 connector. Connect free end of flask whip to <b>AIR SUPPLY OUT</b> valve (AHP-V502) connector on the same rack. Tighten both connectors.

## SS500-HK-MMO-010

Table 2-18. Postmission Procedures: Configurations 1, 2, and 3—Continued

Step	Procedure
<b>PART II - POSTMISSION PROCEDURES FOR CONFIGURATIONS 2 AND 3—Continued</b>	
18	If multiple flask rack assemblies are used: Unbag/uncap flask whip connected to top rack's <b>AIR SUPPLY NEXT RACK</b> valve (AHP-V501). Disconnect flask whips from all secondary flask rack <b>AIR SUPPLY OUT</b> valve (AHP-V502) connectors. Loosen all secondary flask rack AHP-V501 connectors and connect free end of each flask whip to AHP-V502 connectors on the same rack. Tighten both connectors.
19	Remove roof rack assembly from last stack of primary flask rack assemblies.
20	Unstack flask rack assemblies.
<p><b>NOTE</b></p> <p>The following step may be omitted if flasks have been charged with a compressor package using any of the air purification systems found on the ANU list, section 6.1, or any HP air source that provides air at a dew point of -50°F or lower.</p>	
21	Drain moisture from flasks in accordance with the following:
	a. Open flask rack <b>GAUGE ISOLATION</b> valve (AHP-V503) and <b>AIR SUPPLY THIS RACK</b> valve (AHP-V504). Verify <b>MANIFOLD PRESSURE</b> gauge AHP-G508 reads 0 psig; if not, vent pressure from system. Close AHP-V503 and AHP-V504.
	b. Disconnect flask whips from flask valve connectors.
	c. With the valve end pointing down, tilt rack approximately 30 degrees (minimum).
	d. Slowly open each flask shutoff valve. Drain moisture from flasks and close valves.
	e. Repeat steps a thru d for remaining racks. Reposition racks and reconnect flask whips.
f. Return equipment to readiness condition.	
<p><b>NOTE</b></p> <p>NID solution is prepared by mixing 1 teaspoon nonionic detergent to 1 gallon of warm, fresh water.</p>	
22	Wash system exterior with NID solution; rinse with fresh water and dry thoroughly.
23	Inspect system for damage. Accomplish applicable PMS actions. Stow system.

## SS500-HK-MMO-010

**2.4 EMERGENCY PROCEDURE**

The procedure in Table 2-19 contains a detailed description of the steps required for an emergency response to loss of primary air. Appendix A contains a corresponding checklist (EP-1) that may be photocopied for use in the event of an emergency involving loss of the primary air supply.

**Table 2-19. Emergency Procedure: Loss of Primary Air**

Step	Procedure
	<p style="text-align: center;"><b>NOTE</b></p> <p>Record notes and deficiencies in section provided at the end of EP-1 in Appendix A.</p> <div style="border: 2px solid black; padding: 10px; margin: 10px auto; width: 80%;"> <p style="text-align: center;"><b>WARNING</b></p> <p><b>If primary supply pressure drops below minimum manifold pressure, immediately perform the procedure below. Failure to perform this procedure could result in injury or death to divers.</b></p> </div>
1	Switch control console <b>SUPPLY SELECTOR</b> valve (ALP-V302) to <b>SECONDARY SUPPLY</b> .
2	Notify and retrieve divers.
	<p style="text-align: center;"><b>NOTE</b></p> <p>Upon recovery of divers, refer to Chapter 5 of LWDS MK 3 Mod 0 Operation and Maintenance Manual, NAVSEA SS500-HK-MMO-010, to isolate the cause of the failure.</p>

**2.5 FAILURE ANALYSIS REPORTING**

In order to maintain system certification and standardize reporting, tracking, and resolving of material failures or deficiencies in the LWDS MK 3 Mod 0, a Failure Analysis Report (FAR), NAVSEA Form 10560/4 (Figure 2-18), should be submitted as soon as possible when any of the following occurs:

- a. An equipment or component malfunction occurs
- b. Unscheduled repairs are performed
- c. An unscheduled adjustment is required

## SS500-HK-MMO-010

- d. An equipment deficiency is noted
- e. A defective component or spare part is detected

Contact numbers and addresses are provided on the reverse side of the FAR form and may be used to obtain more information.

An electronic version of the FAR form is available on-line at <http://www.supsalv.org>. When the home page appears, place cursor on **00C3 Diving** and then on **Diver Support Menu**. Next, click on **Failure Analysis Report**, then follow the instructions and submit the form. If the failure also meets the criteria in paragraph 2.6, the equipment shall be immediately secured and handled accordingly.

## **2.6 ACCIDENT/INCIDENT EQUIPMENT STATUS REPORTING**

The following definition of accidents and incidents is taken from Volume 1, paragraph 5-10 of the *U.S. Navy Diving Manual*, NAVSEA SS521-AG-PRO-010:

*“An **accident** is an unexpected event that culminates in loss of or serious damage to equipment or injury to personnel. An **incident** is an unexpected event that degrades safety and increases the probability of an accident.*

*The number of diving accidents/incidents involving U.S. Navy divers is small when compared to the total number of dives conducted each year. The mishaps that do occur, however, must receive a thorough review to identify the cause and determine corrective measures to prevent further diving mishaps.”*

Accident/incident equipment status reporting is mandatory for all diving units in each of the following cases:

- a. Whenever an accident/incident results in a fatality or serious injury
- b. Whenever an equipment malfunction or inadequate performance may have contributed to an accident/incident

Detailed reporting procedures are provided in Volume 1, Chapter 5 of the *U.S. Navy Diving Manual*. Personnel should be familiar with the reporting process before a mishap occurs to ensure expeditious reporting and proper care and handling of the affected equipment.

### **NOTE**

Full completion of a FAR form in response to a diving accident/incident equipment investigation is limited. The FAR cannot be fully and accurately completed by the user unit since disassembly/investigation of equipment prior to receiving instructions from or inspection by a designated NAVSEA 00C3 representative is prohibited. In view of this restriction, the FAR should be completed to the extent that it will provide helpful and relevant information to the investigation.





## SS500-HK-MMO-010

**INSTRUCTIONS**

Legible, handwritten copies (black ballpoint pen preferred) are acceptable. Blocks 1, 2, 3, 4, 6, and 7 must be filled in completely; all other blocks should be filled in as required. When information is not available, write NONE. When more space is required, use Block 11 and blank paper as needed; **identify each added page with the information provided in Blocks 2 and 3 and number pages** (example: "page 2 of 3").

**BLOCK**

2. Enter your command Unit Identification Code (UIC) and FAR Serial Number from command FAR log (sequential numbering as issued).
6. Enter the exact name of the system in which the failure was experienced (ex: Lightweight Dive System (LWDS) MK 3 Mod 0). Enter the serial number of the pertinent assembly (ex: Control Console Assembly SN 12345).
7. Enter the lowest item (may be assembly or part) in which the failure was located by name and by part number **as identified by the system technical manual** (ex: HP Regulator Assembly, PR50-6). Use MS, SAE, National Stock Number, etc., only if a system part number is not available, and describe the application in Block 11.
8. Check the appropriate box(es) as required. Note that "Technical Documentation" should be checked if the technical manual, Planned Maintenance System (PMS), Allowance Parts List (APL), or other documentation inadequately supports operation or maintenance; identify the inadequate document and page number(s) in Block 11. Block 11 must be used if "OTHER" is checked.
9. Copy contract number from spare part tag and check appropriate boxes.
11. Complete this block to further explain any items from Blocks 1 through 10 as required; identify each item by Block Number. Suggestions on failure corrections and system improvements are encouraged. Attach pages (descriptions, sketches, etc.) as required and identify each page with the information provided in Blocks 2 and 3.

**DISTRIBUTION**

ORIGINAL FAR TO:           **COMMAND FAR LOG**

COPIES TO:               (1) **COMMANDER, NAVAL SEA SYSTEMS COMMAND  
ATTN 00C33  
1333 ISAAC HULL AVENUE SE STOP 1073  
WASHINGTON NAVY YARD DC 20376-1073**

(2) **COMMANDING OFFICER  
COASTAL SYSTEMS STATION  
DAHLGREN DIVISION, CODE E53  
6703 WEST HIGHWAY 98  
PANAMA CITY FL 32407-7001**

(3) **NAVY EXPERIMENTAL DIVING UNIT  
IN-SERVICE ENGINEERING  
321 BULLFINCH ROAD  
PANAMA CITY FL 32407-7015**

NAVSEA 10560/4 (10/86)(Back)

**Figure 2-18. Failure Analysis Report (FAR) Form (Sheet 2 of 2)**

SS500-HK-MMO-010

## CHAPTER 3

### FUNCTIONAL DESCRIPTION

#### 3.1 INTRODUCTION

This chapter defines the functions of the major assemblies and subassemblies that make up the Lightweight Dive System (LWDS) MK 3 Mod 0. Each assembly and its associated function are discussed separately at progressively increasing levels of detail. The first level of the functional description describes the major function of the LWDS as a life support breathing system. The second level of the functional description explains equipment functions of the major assemblies down to the subassembly level.

The major assemblies and subassemblies of the LWDS are as follows:

- | <u>Major Assemblies</u>      | <u>Major Subassemblies</u>        |
|------------------------------|-----------------------------------|
| ● Diesel-Compressor Assembly | ● Roof Rack Assembly              |
| ● Primary HP Air Supply      | ● Interconnecting Hose Assemblies |
| ● Volume Tank Assembly       |                                   |
| ● Control Console Assembly   |                                   |
| ● Secondary HP Air Supply    |                                   |

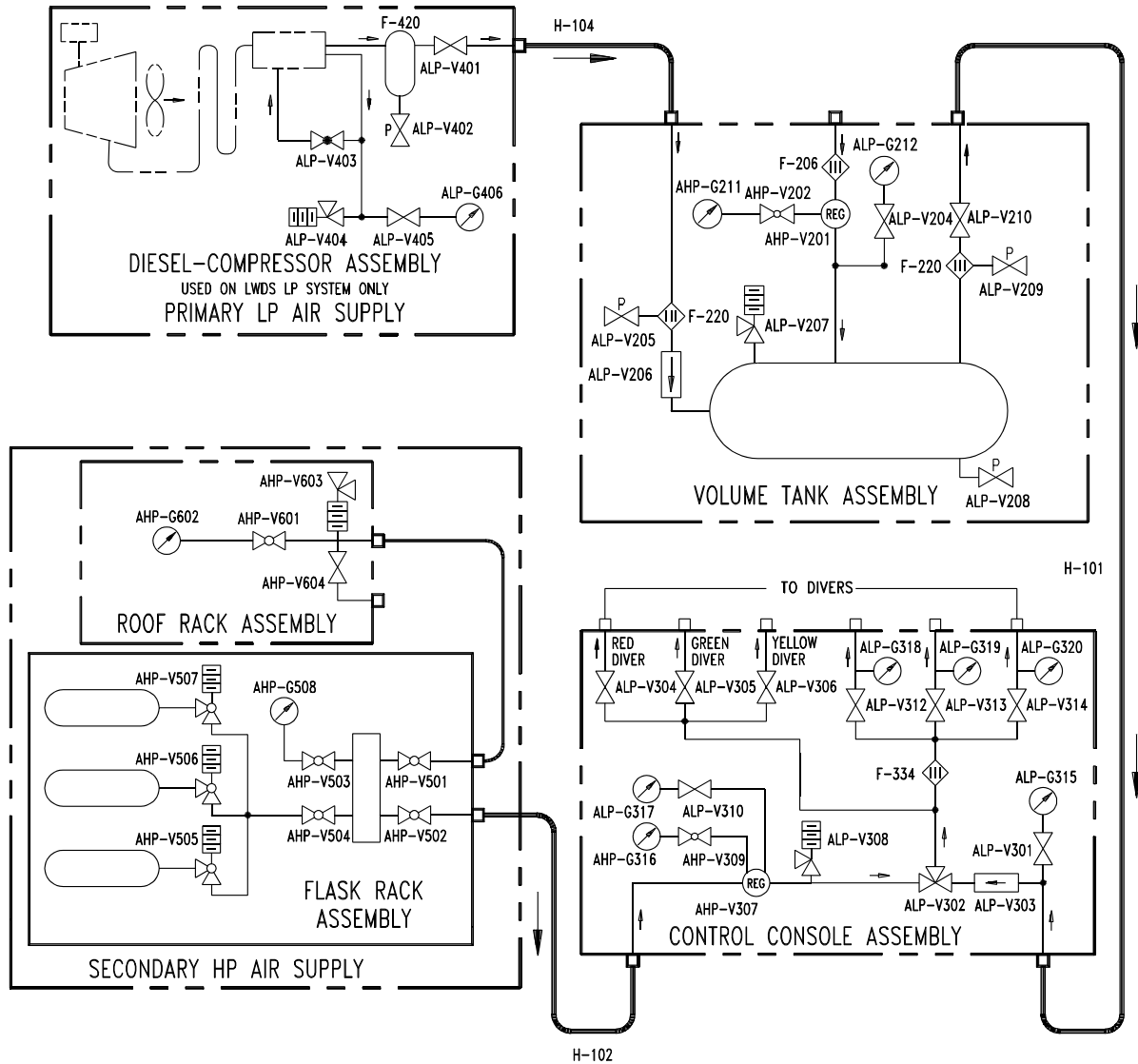
#### 3.2 LWDS BREATHING SYSTEM

The LWDS uses one of three equipment configurations to provide breathing air to two working divers (and one standby diver) operating at a moderately heavy work rate to a maximum dive depth of 60 feet of seawater (fsw) with Configuration 1, 130 fsw with Configuration 2, and 190 fsw with Configuration 3. Paragraph 3.2.1 describes how primary air is supplied in each configuration. A secondary (emergency) high pressure (HP) air supply (paragraph 3.2.2) is available in all three configurations should component failure occur upstream from the control console assembly and cause loss of the primary air supply. Functional diagrams showing the complete flow of primary and secondary air as supplied by the LWDS in Configurations 1, 2, and 3 are provided as Figures 3-1, 3-2, and 3-3, respectively. Figure 3-4 serves as an additional reference for Configuration 3 when multiple stacks of flask racks are required for the dive mission.

**3.2.1 PRIMARY AIR SOURCE.** Primary air for the LWDS is supplied as low pressure (LP) air from the diesel-compressor assembly (Configuration 1) or as HP air from a minimum of three flask rack assemblies (Configurations 2 and 3). All primary air supply components are interconnected by hose assemblies.

**3.2.1.1 Configuration 1.** LP air from the diesel-compressor assembly passes through a moisture separator, then flows to the volume tank assembly where it is filtered and transferred to the control console assembly. At the control console assembly, control valves direct the LP air into the diver umbilicals. This air flow path is shown in Figure 3-1.

SS500-HK-MMO-010



CONFIGURATION 1

COMPONENT LEGEND

	PLUG VALVE		PRESSURE GAUGE		ANGLE SHUTOFF VALVE W/RELIEF
	BALL VALVE		REGULATOR MANUAL ADJUST		FILTER
	CHECK VALVE		SHUTOFF VALVE (NEEDLE)		PILOT VALVE
	RELIEF VALVE		ANGLE SHUTOFF VALVE (NEEDLE)		SELECTOR VALVE

Figure 3-1. LWDS MK 3 Mod 0 Functional Diagram, Configuration 1

SS500-HK-MMO-010

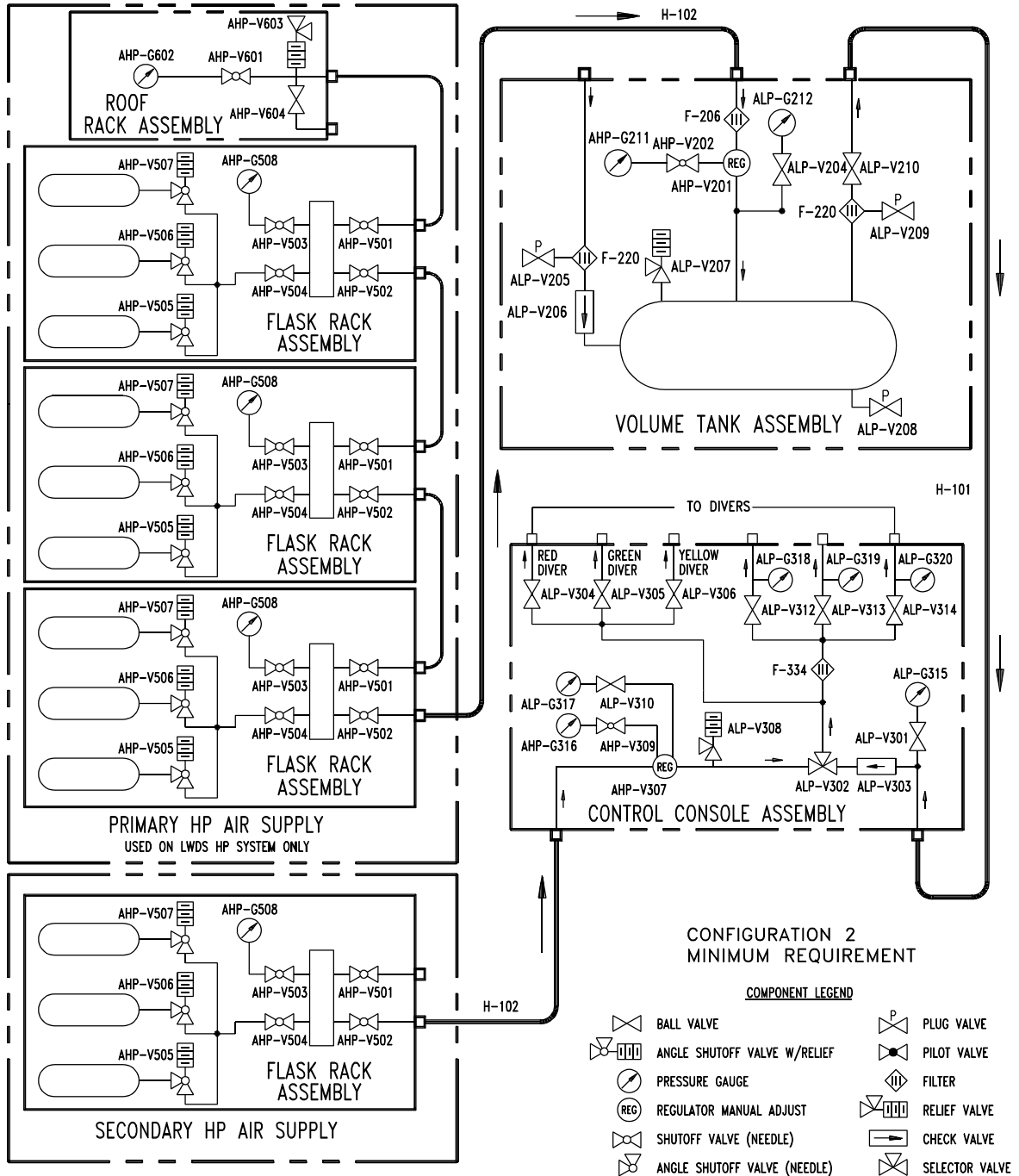


Figure 3-2. LWDS MK 3 Mod 0 Functional Diagram, Configuration 2

SS500-HK-MMO-010

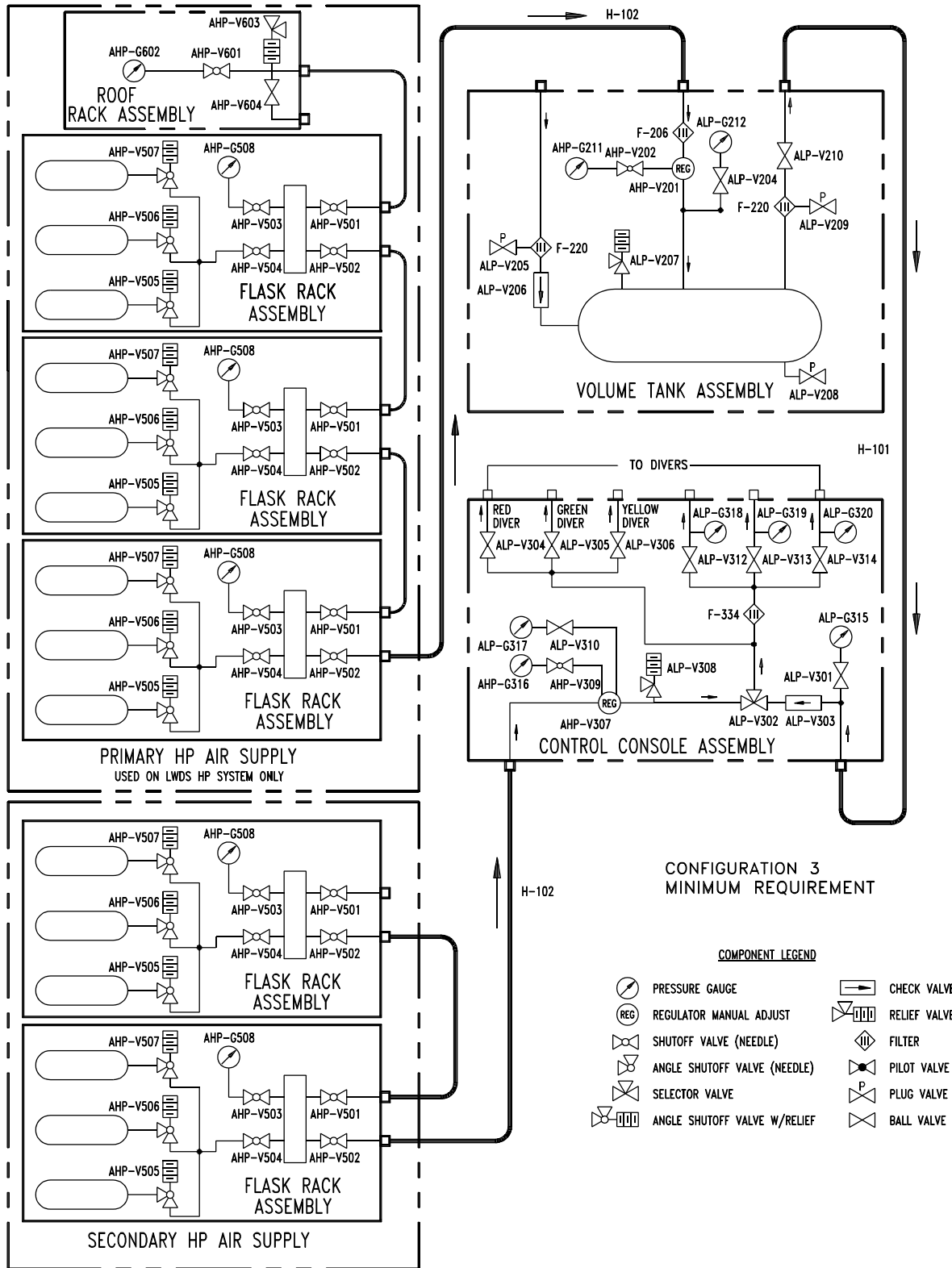
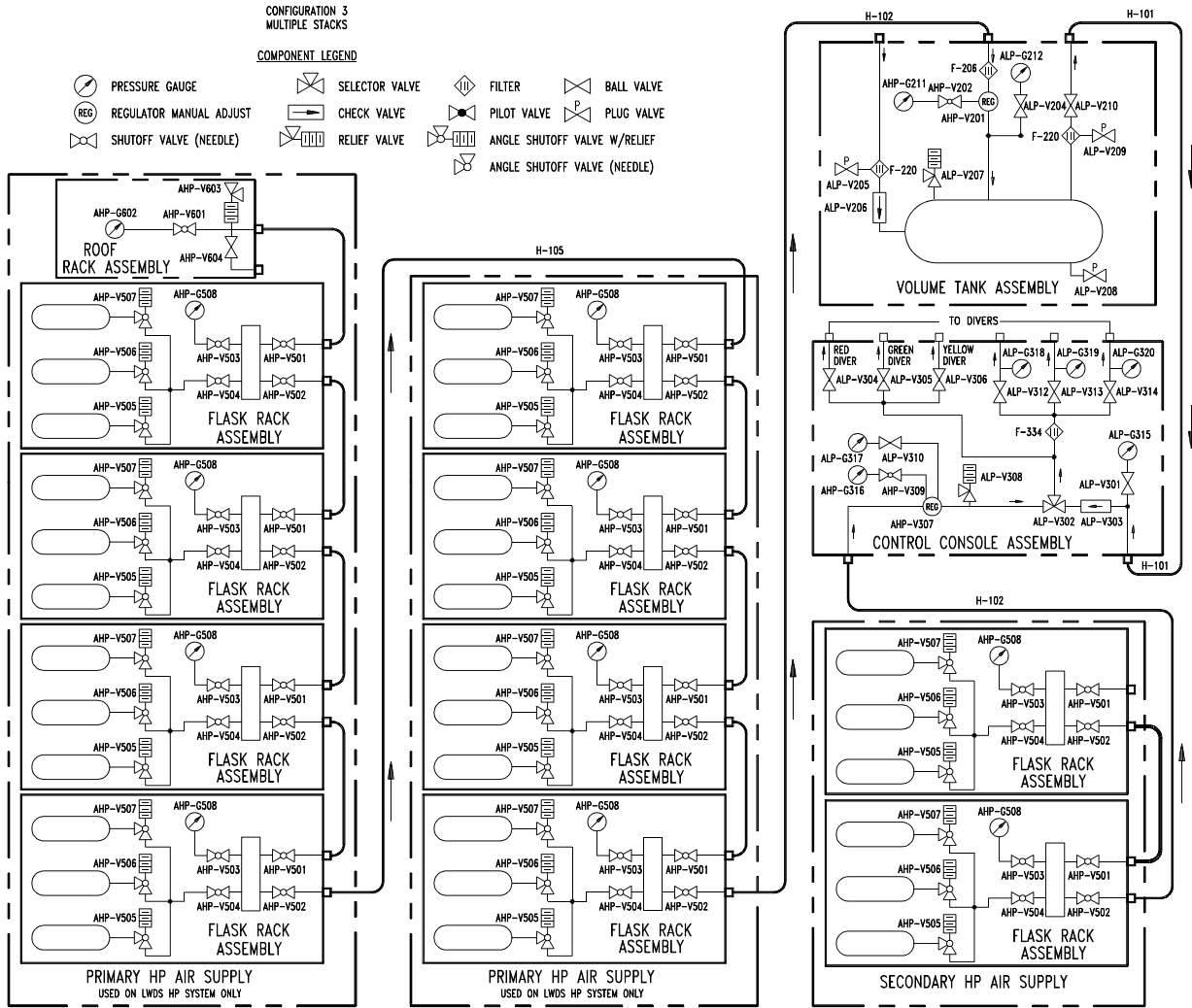


Figure 3-3. LWDS MK 3 Mod 0 Functional Diagram, Configuration 3

# SS500-HK-MMO-010



**Figure 3-4. LWDS MK 3 Mod 0 Functional Diagram, Multiple Stacks of Flask Racks, Configuration 3**

## SS500-HK-MMO-010

**3.2.1.2 Configurations 2 and 3.** When the primary HP air supply is used in Configurations 2 and 3, HP air flows directly to the volume tank assembly where it is filtered and then reduced to LP air through a regulator. The LP air is supplied to the divers in the same manner as in Configuration 1. The primary air flow path for Configuration 2 is shown in Figure 3-2. The air flow paths for Configuration 3 are shown in Figure 3-3 (minimum requirements) and Figure 3-4 (multiple stacks of flask racks).

**3.2.2 SECONDARY AIR SOURCE.** Regardless of the equipment configuration used, the secondary HP air supply is connected to the control console assembly during normal operations to ensure immediate availability of an emergency air supply (see Figures 3-1 through 3-4). HP air is reduced to LP air through the control console assembly.

In case of system failure upstream of the control console assembly, the secondary HP air supply may be directed to the diver umbilicals by switching the three-way selector valve on the control console assembly to the SECONDARY SUPPLY position.

### **3.3 LWDS EQUIPMENT FUNCTIONS**

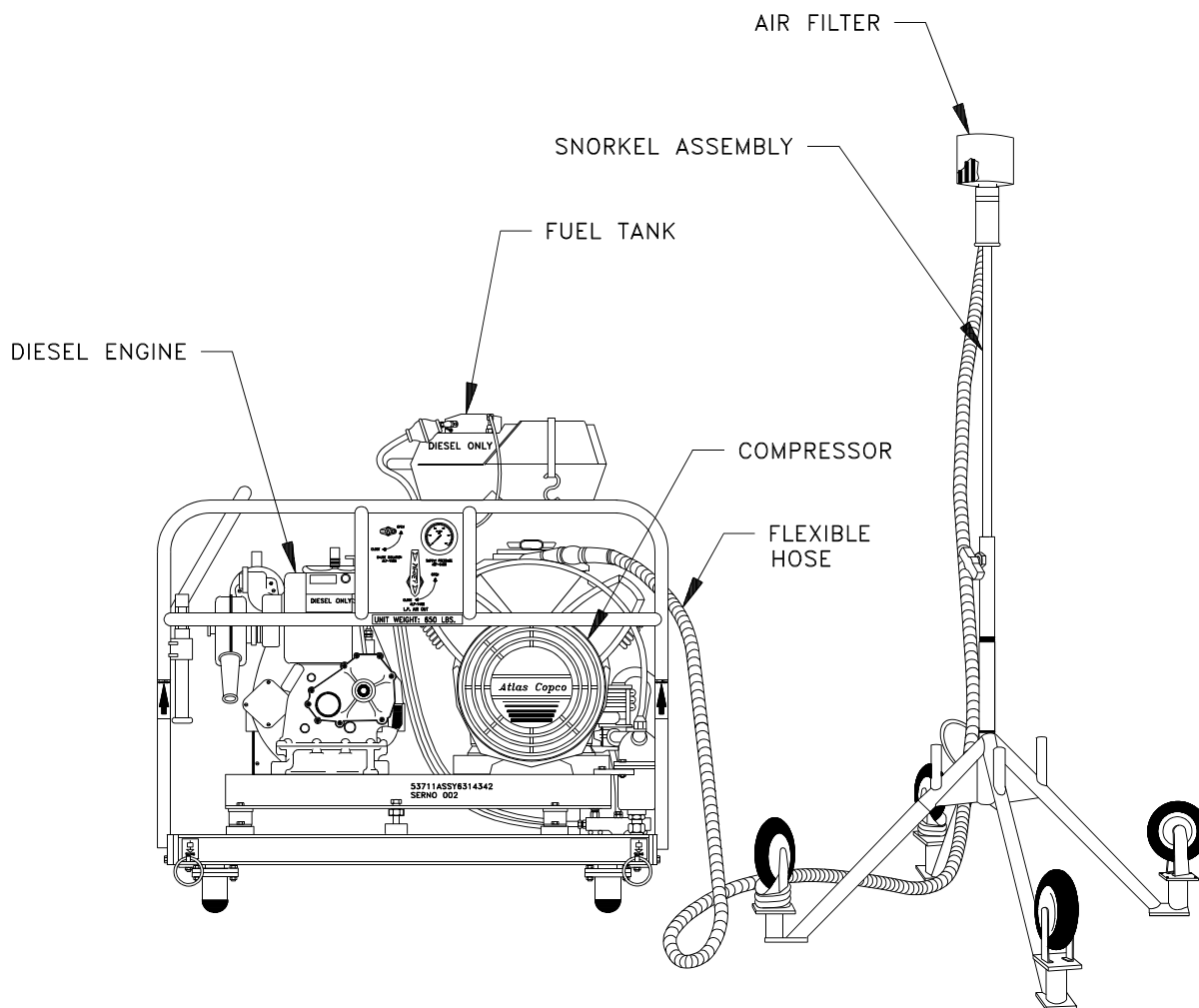
**3.3.1 DIESEL-COMPRESSOR ASSEMBLY.** The diesel-compressor assembly (Figure 3-5) consists of a diesel engine and a compressor. The snorkel assembly (Figure 3-5) is a primary subassembly of the diesel-compressor assembly. These assemblies function jointly to produce primary LP air when using the LWDS in Configuration 1.

**3.3.1.1 Diesel Engine.** The two-cylinder, air-cooled, Lister Petter Model LV2 diesel engine is connected to the compressor unit by a belt drive. The diesel engine has a displacement of 954 cubic centimeters and develops 18 brake horsepower at 3,000 revolutions per minute (rpm). The engine's fuel tank is mounted to the frame of the diesel-compressor assembly and has a 6-gallon capacity. The oil sump capacity is 3.8 U.S. quarts. Fuel consumption under load is 0.5 gallon per hour. A fuel and lubrication chart provided in Chapter 2 (Figure 2-17) lists the types and grades of diesel fuel and lubricating oil recommended for use in the diesel engine.

**3.3.1.2 Compressor.** The compressor is an air-cooled, belt-driven Atlas Copco Model LT8. Two cylinders in series provide two-stage compression. Initially, air is drawn through the intake filter, the intake manifold, and then into the LP cylinder where it is compressed, discharged, and cooled through the delivery valve and intercooler. Air then passes through the pulsation damper and suction disk, where it enters the final compression stage. After final compression, air is discharged through the delivery disk to the aftercooler and then passes through the check valve and moisture separator. An unloader pilot valve senses pressure and controls the compressor unloader valve. An interstage pressure-relief valve protects the compressor in case of blockage between the first and second stages, and a final stage pressure-relief valve prevents overpressurization of the compressor unit.

The compressor delivers a working pressure of 175 pounds per square inch gauge (psig) and a flow of 18.6 standard cubic feet per minute (scfm) at 1,800 rpm. The load setting of the compressor is  $145 \pm 5$  psig and the unload setting is  $165 \pm 5$  psig. The lubricating oils recommended for use in the compressor are listed in the fuel and lubrication chart in Chapter 2 (Figure 2-17).

### SS500-HK-MMO-010



**Figure 3-5. Diesel-Compressor Assembly with Snorkel Assembly**



## SS500-HK-MMO-010

**3.3.1.3 Snorkel Assembly.** The snorkel assembly (Figure 3-5) consists of a flexible hose, an intake assembly containing an air filter system, and a telescoping frame consisting of a stand and leg weldments. The snorkel assembly supplies particle-free air to the compressor intake. It may be placed at a remote site not more than 20 feet from the diesel-compressor assembly, taking into account 4-1/2 to 6 feet for the height of the stand. The intake assembly can be removed from its frame and secured to a taller support, if desired.

**3.3.2 PRIMARY HP AIR SUPPLY.** Primary HP air is supplied from a minimum of three flask racks each containing three composite air flasks (Figure 3-6). Air from the flasks is directed to the lowest primary flask rack manifold and then by an interconnecting hose to a manually adjustable regulator on the volume tank assembly.

Each flask is 30.55 inches long, 10.22 inches in diameter, and weighs 29.5 pounds (empty). The flask floodable volume is 0.935 cubic feet with a service pressure of 3,000 psig and air capacity of 191 standard cubic feet (scf). A frangible disk safety device protects each flask from overpressure. The disk ruptures at 5,000 pounds per square inch (psi), venting HP air from the flask.

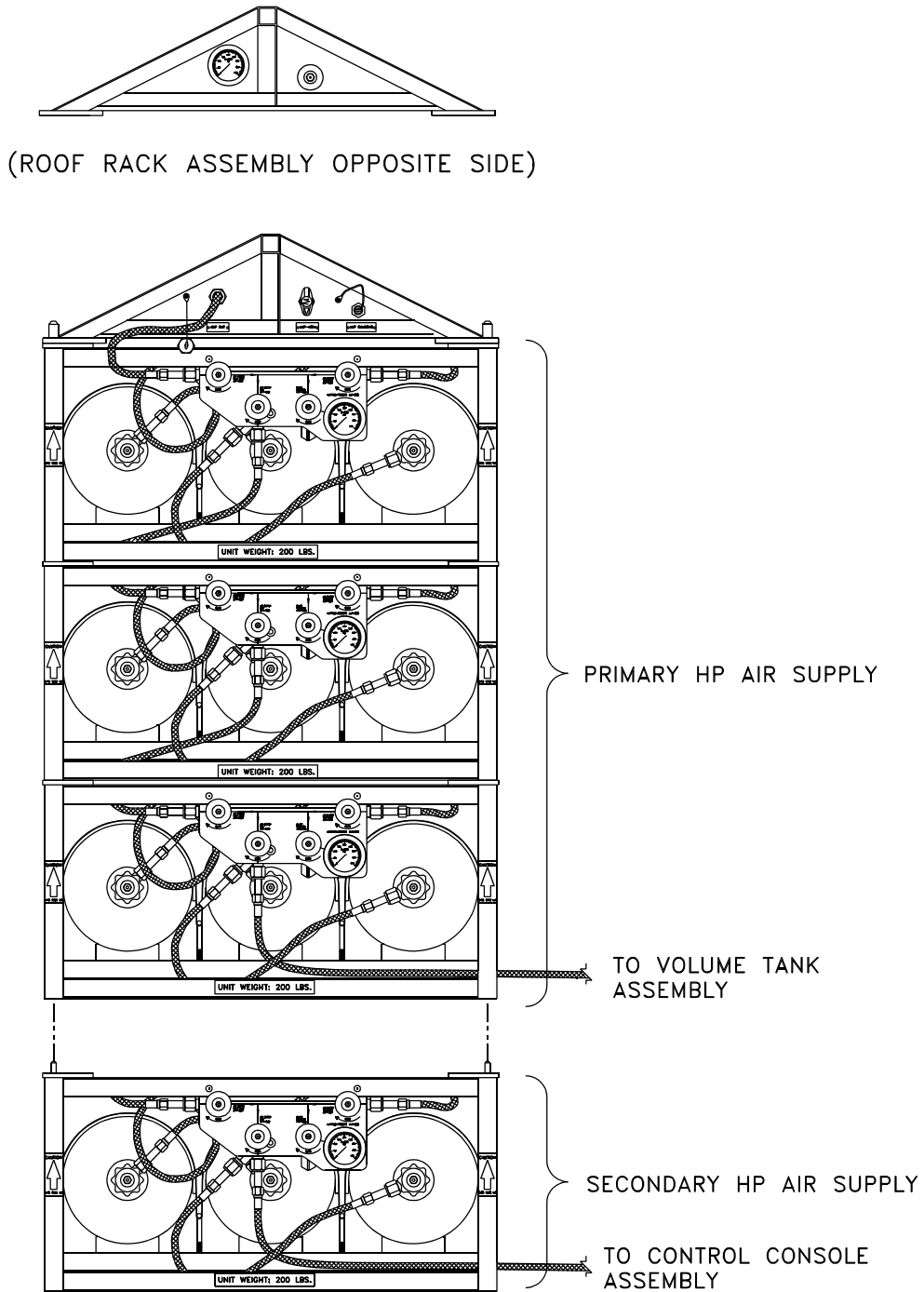
When scheduled dive air requirements exceed the capacity of one stack of flask rack assemblies, the HP air flasks may be recharged, more flask rack assemblies added, or a combination thereof may be used without interruption of the mission. Each stack of flask rack assemblies shall not exceed four high. When multiple stacks are used, the stacks are interconnected (see Figure 3-4) and the roof rack assembly is placed on the last stack.

**3.3.3 VOLUME TANK ASSEMBLY.** The volume tank assembly (Figure 3-7) primarily serves as a supply reservoir for compressed air. In addition, filters in the assembly remove moisture and contaminants from diver air before delivery to the control console assembly. LP air from the diesel-compressor assembly (Configuration 1) flows through a coalescent filter system mounted to the volume tank assembly frame. After filtration, the air passes through a check valve into the volume tank. HP air from the primary HP air supply flask rack assemblies (Configurations 2 and 3) flows through an in-line filter, through a regulator where it is reduced to LP air, and then into the volume tank. From the volume tank, LP air flows through a second frame-mounted coalescent filter and to a control valve for distribution to the control console assembly.

**3.3.3.1 Volume Tank.** Moisture from incoming air is removed in the volume tank by condensation through natural cooling. Water collected in the tank is removed through a manually-operated drain valve. The 30-gallon volume tank also serves to dampen pressure pulsations created by the compressor in Configuration 1. Incoming primary air flows through a check valve to prevent loss of pressure in the event of a rupture in the interconnecting hose or failure of the diesel-compressor assembly.

**3.3.3.2 Filters.** The volume tank assembly includes three filters: an HP particle filter and two identical LP filters. The HP filter is located before the regulator in the primary HP supply inlet line. The HP filter must be inspected and cleaned or replaced periodically. The LP filters include a primary supply pre-filter and an outlet final filter. These filters remove entrained hydrocarbons, condensate, and particulate matter greater than 0.1 micron from the air. Each LP filter housing is equipped with a drain valve.

### SS500-HK-MMO-010



### MINIMUM REQUIREMENT

Figure 3-6. Primary and Secondary HP Air Supplies, Configuration 2

# SS500-HK-MMO-010

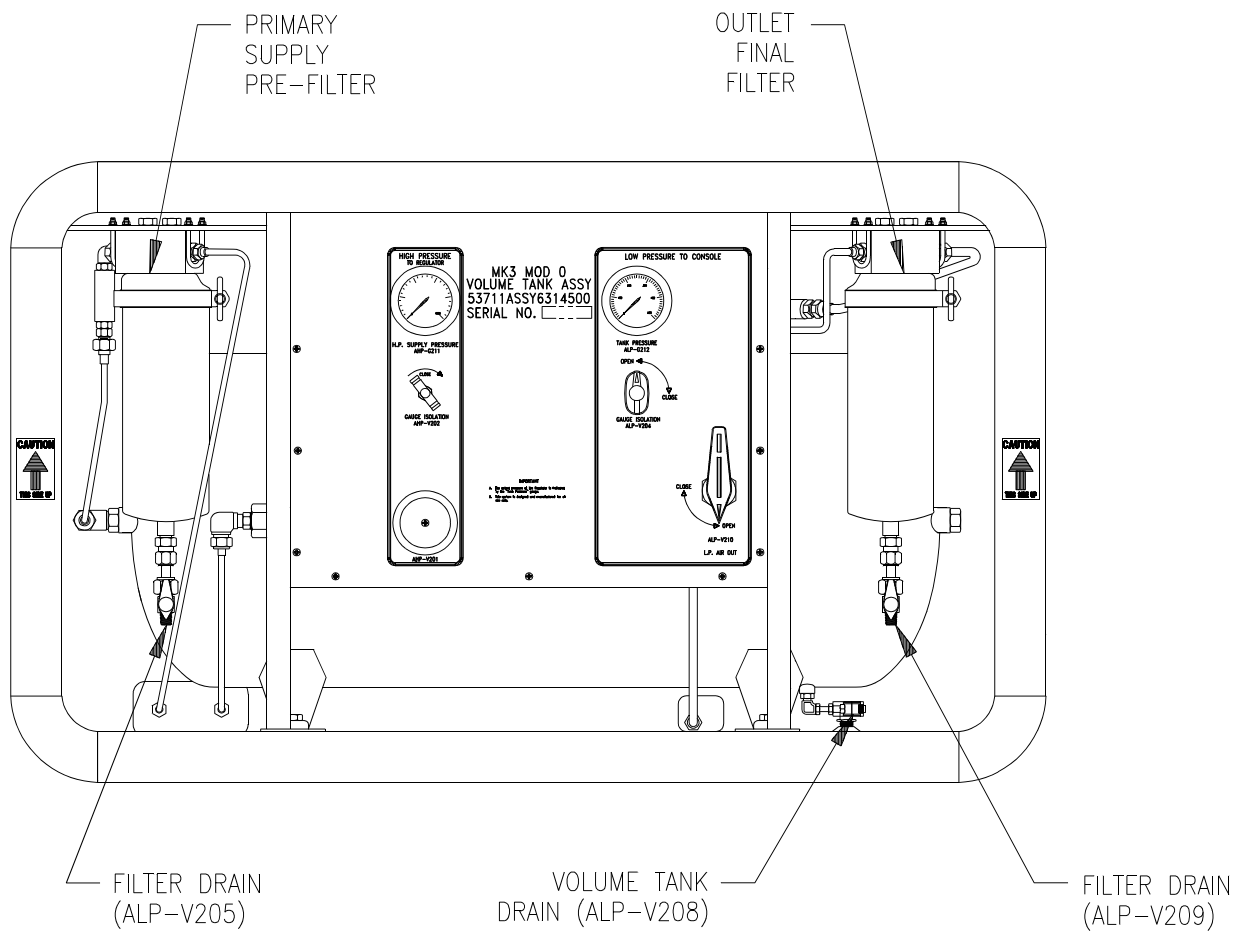


Figure 3-7. Volume Tank Assembly

## SS500-HK-MMO-010

**3.3.4 CONTROL CONSOLE ASSEMBLY.** Control of diver air and pneumofathometer air flow in the LWDS is provided by the control console assembly (Figure 3-8). LP air from the volume tank assembly and HP air from the secondary air supply enters the control console assembly through marked fittings. Air from the secondary HP air supply is directed from the flask rack to a manual adjust regulator in the console. The air is regulated and directed through control valves to the diver umbilicals. Pressure gauges in the console allow the operator to monitor the primary or secondary air supply. The console also contains pneumofathometer gauges to monitor diver depth and provides a depth readout for each diver. Each umbilical contains a pneumofathometer hose through which air pressure proportional to diver depth is sensed. Under normal conditions, primary air is used to purge the pneumofathometer hose. The supply selector valve is used to either select primary LP air for normal operations or switch to secondary HP air in the event of an emergency.

**3.3.5 SECONDARY HP AIR SUPPLY.** The secondary HP air supply (Figures 3-6 and 3-9) is contained in one or more flask racks, each containing three composite flasks identical to the primary HP air supply flasks. The secondary air is connected directly to the control console assembly and controlled through a manual adjust regulator and supply selector valve. The secondary HP air supply is used as an emergency air supply in case of primary air supply failure.

**3.3.6 ROOF RACK ASSEMBLY.** One roof rack assembly is supplied with the LWDS MK 3 Mod 0 for use with the primary or secondary HP air supply. During setup procedures, the roof rack assembly is placed on the secondary HP air supply in Configuration 1 (see Figure 3-9) or on the topmost in-line primary HP flask rack assembly in Configurations 2 and 3 with the AHP CHARGING port on the same side as the flask rack manifold. During start-up, the flask whip from the AIR SUPPLY NEXT RACK valve (AHP-V501) on the topmost in-line flask rack assembly is connected to the roof rack assembly's AHP OUT port. Opening AHP-V501 and roof rack valves AHP-V601 and AHP-V604 (see below) pressurizes the roof rack assembly.

The primary functions of the roof rack assembly are to provide a single location for monitoring the air pressure of the in-line flask rack assemblies and to provide a single charging point for charging the flasks. In order to make these functions possible, the flasks within each flask rack assembly are connected to a manifold, which is then connected to the manifold of the next higher in-line flask rack assembly, or if the topmost assembly, to the roof rack assembly. This interconnection allows the air in the flasks to "cascade" or flow from one flask rack assembly to the next, which results in similar pressure levels in all the in-line flask rack assemblies and the roof rack assembly. A single pressure reading can then be taken from the roof rack assembly via HP pressure gauge (AHP-G602), which is located at the rear of the roof rack assembly along with roof rack gauge isolation valve (AHP-V601). AHP-V601 must be open for AHP-G602 to operate. The cascading action also comes into play when the flasks are being charged. During HP flask charging procedures, an HP compressor hose is connected to the roof rack assembly's AHP CHARGING port. When roof rack charge inlet valve (AHP-V604) is opened, HP air from the compressor flows through the AHP CHARGING port and is forced out through the flask whip connected to the AHP OUT port. From there, the air flows through the opened valves in each in-line flask rack assembly and fills the flasks. When the pressure reaches 3,000 psig on AHP-G602, the valves should be closed. If the pressure is allowed to reach 3,300 psig, the roof rack HP relief valve (AHP-V603) will open and relieve the

SS500-HK-MMO-010

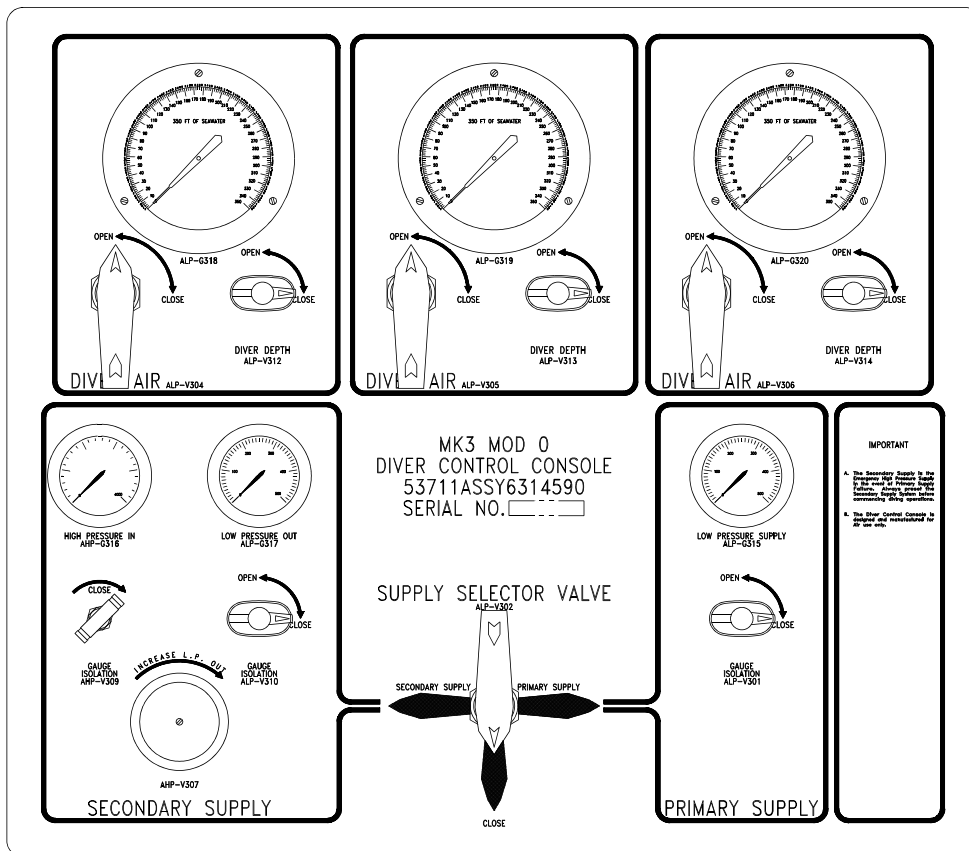
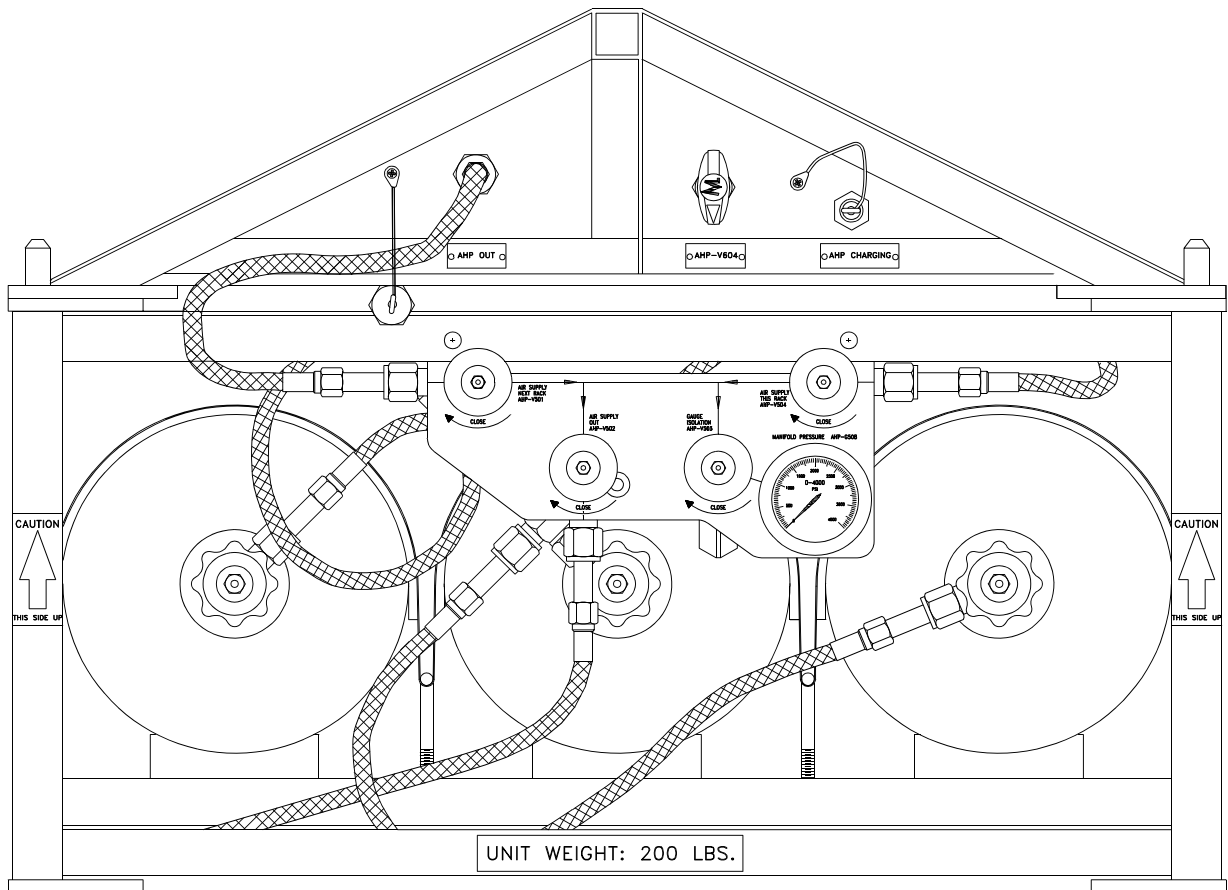


Figure 3-8. Control Console Assembly

### SS500-HK-MMO-010



**Figure 3-9. Secondary HP Air Supply with Roof Rack Assembly, Configuration 1**

## SS500-HK-MMO-010

pressure until it is reduced below 3,300 psig. If the relief valve opens, the compressor should be shut down and the flask valves opened until AHP-G602 reads 3,000 psig.

**3.3.7 INTERCONNECTING HOSE ASSEMBLIES.** The interconnecting hose assemblies are used to interconnect major assemblies of the LWDS MK 3 Mod 0 in the chosen equipment configuration (see Figure 3-10). The flask rack interconnecting hose assemblies (flask whips) are used to connect the flasks to the manifold in each flask rack assembly and to connect the manifold to an adjoining flask rack assembly or to the roof rack assembly. The interconnecting hose assemblies for the LWDS MK 3 Mod 0 are summarized below and discussed in the following paragraphs:

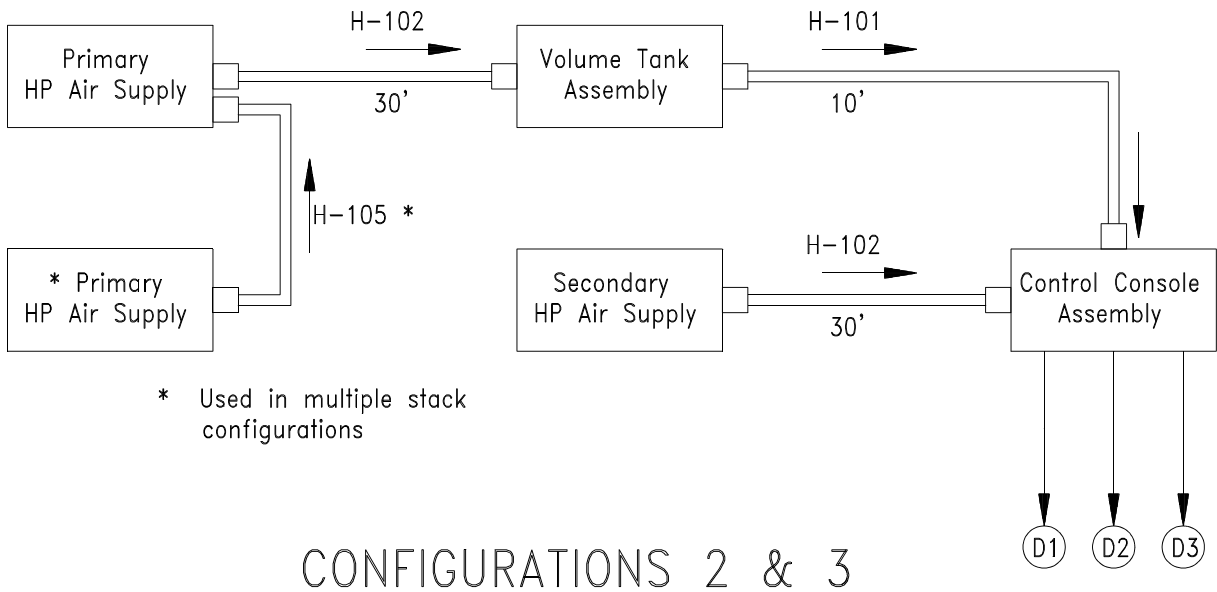
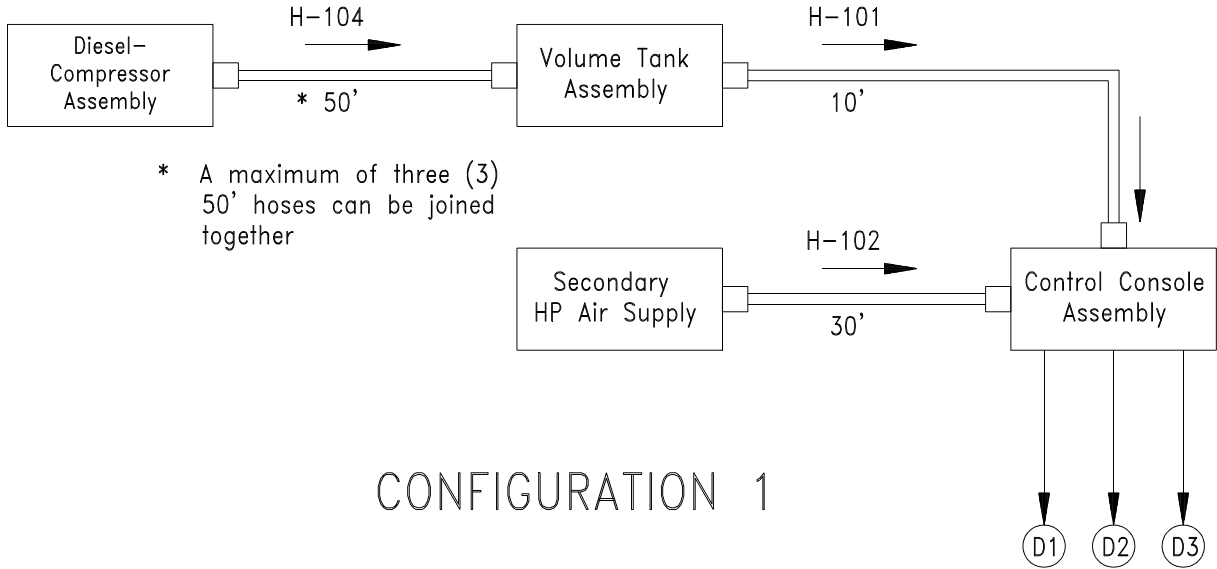
- H-101—Volume Tank to Control Console Hose Assembly (all configurations)
- H-102—Primary HP Air to Volume Tank Hose Assembly (Configurations 2 and 3)
- H-102—Secondary HP Air to Control Console Hose Assembly (all configurations)
- H-104—Diesel-Compressor to Volume Tank Hose Assembly (Configuration 1)
- H-105—Primary HP Air to Primary HP Air Hose Assembly (interconnects multiple stacks in Configurations 2 and 3)
- Flask Rack Interconnecting Hose Assemblies (all configurations)

**3.3.7.1 H-101—Volume Tank to Control Console Hose Assembly.** H-101 is used in all configurations to connect the volume tank assembly to the control console assembly. The hose assembly consists of a 10-foot length of 1/2-inch inside diameter (ID) rubber diver hose with 37° flare fittings that feature 3/4-16 threads to prevent accidental connection to the diesel-compressor assembly. A 3/16-inch coated stainless steel cable is strapped to the air hose for safety. The rated working pressure for this hose is 250 psi.

**3.3.7.2 H-102—Primary HP Air to Volume Tank or Secondary HP Air to Control Console Hose Assembly.** There are two identical hose assemblies designated as H-102, one of which is used in Configurations 2 and 3 to connect a single stack of primary flask rack assemblies to the volume tank assembly. Multiple stacks are interconnected with H-105 (see paragraph 3.3.7.4), with the lowest in-line stack connected to the volume tank assembly with H-102. The other H-102 assembly is used in all configurations to connect a single stack of secondary flask rack assemblies to the control console assembly. The H-102 hose assembly consists of a 30-foot length of 3/8-inch ID thermoplastic hose with 37° flare fittings that feature 9/16-18 threads. A 3/16-inch coated stainless steel cable is lashed to the air hose for safety. The rated working pressure for this hose is 3,000 psi.

**3.3.7.3 H-104—Diesel-Compressor to Volume Tank Hose Assembly.** H-104 is used only in Configuration 1 to connect the diesel-compressor assembly to the volume tank assembly. LP air flows through the hose from the compressor outlet at one end to the volume tank pre-filter inlet at the other. The hose assembly consists of a 50-foot length of 1/2-inch ID rubber diver hose with 37° flare fittings that feature 7/8-14 threads to prevent accidental connection to the control console assembly. Three H-104 hose assemblies are supplied with the system and may be coupled up to a total length of 150 feet using 37° flare to 37° flare unions and shackles. A 3/16-inch coated stainless steel cable is strapped to the air hose for safety. The rated working pressure for this hose is 250 psi.

SS500-HK-MMO-010



**Figure 3-10. Interconnecting Hose Assemblies**



## SS500-HK-MMO-010

**3.3.7.4 H-105—Primary HP Air to Primary HP Air Hose Assembly.** H-105 is used in Configurations 2 and 3 to interconnect multiple stacks of primary flask rack assemblies. The hose assembly consists of a user-defined length of 3/8-inch ID thermoplastic hose with CGA-346 fittings. A 3/16-inch coated stainless steel cable is lashed to the air hose for safety. The rated working pressure for this hose is 3,000 psi.

**3.3.7.5 Flask Rack Interconnecting Hose Assemblies.** The flask rack interconnecting hose assemblies (or flask whips) are used in all configurations in both the primary and secondary flask rack assemblies. Four flask whips are supplied with each rack—three are used to connect the three flasks in each rack with the rack manifold and the other is used to connect the rack manifold with an adjoining rack, or if the uppermost rack, with the roof rack assembly. The hose assemblies consist of 24-inch long, 14-inch ID stainless steel overbraided Teflon® hoses with fittings for an overall length of 29-1/2 inches. The rated working pressure for the flask whips is 3,000 psi.

SS500-HK-MMO-010

## CHAPTER 4

### SCHEDULED MAINTENANCE

#### WARNING

**Properly performed scheduled maintenance is essential to safe, dependable diving operations with the Lightweight Dive System (LWDS) MK 3 Mod 0. Omission or negligent performance of prescribed maintenance procedures could result in equipment failure and injury or death to personnel.**

#### 4.1 INTRODUCTION

**4.1.1 PURPOSE.** This chapter provides diving supervisors and qualified maintenance personnel with the information necessary to plan, schedule, and document maintenance efficiently for the Lightweight Dive System (LWDS) MK 3 Mod 0.

**4.1.2 SCOPE.** The information in this chapter is intended to supplement the LWDS MK 3 Mod 0 Planned Maintenance System (PMS) and assist maintenance personnel in using the PMS to safely and effectively perform scheduled maintenance on the LWDS. If conflicts occur between the information in this chapter and that found in the PMS, the PMS takes precedence. Refer to paragraph 4.6 for more information on the PMS for this system.

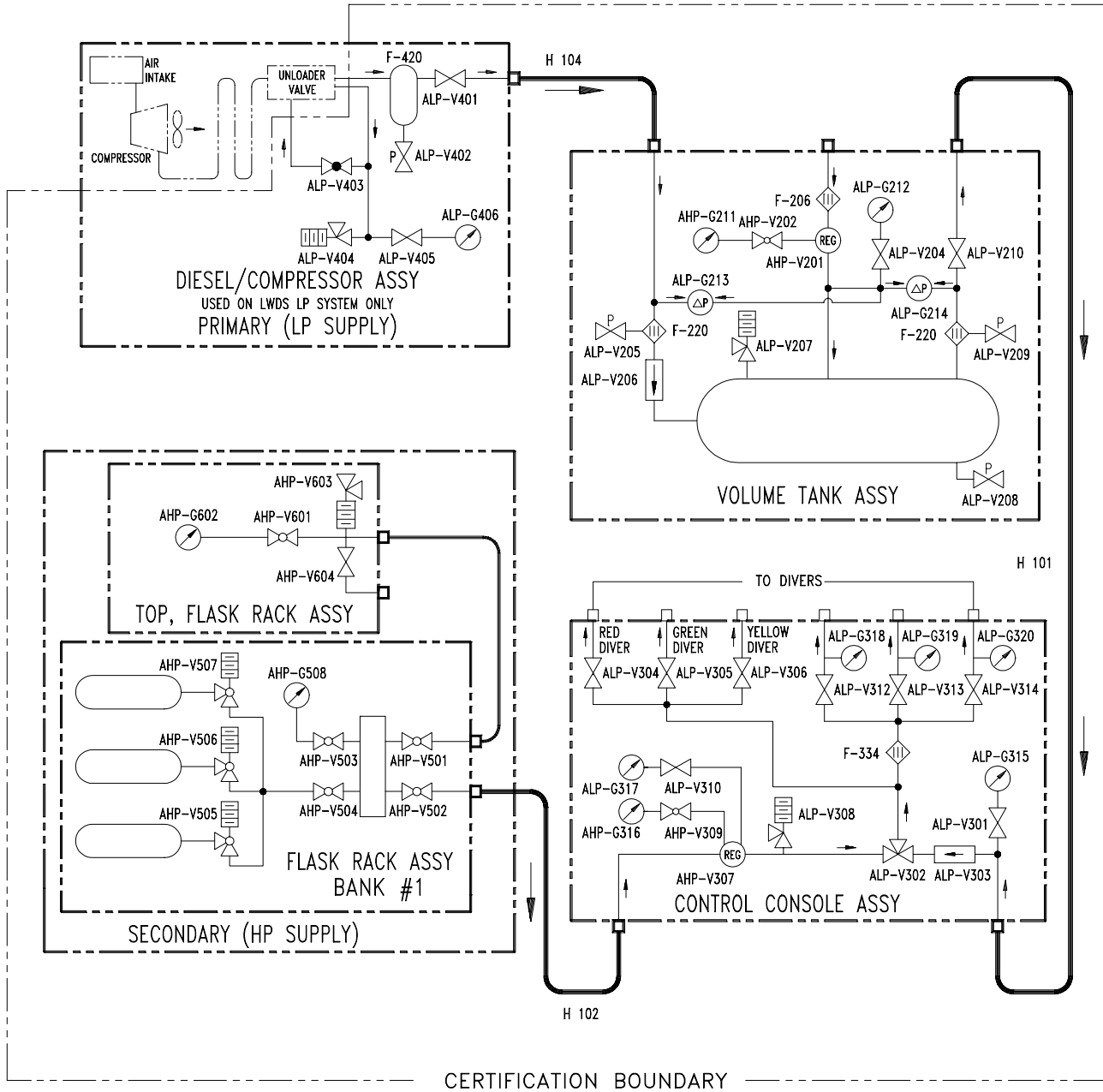
The information in this chapter is arranged as follows:

- Para. 4.2—System Certification and Re-Entry Control (REC) . . . . . Page 4-1
- Para. 4.3—Recordkeeping and Reporting Procedures . . . . . Page 4-3
- Para. 4.4—General Safety Requirements . . . . . Page 4-3
- Para. 4.5—Maintenance Concept . . . . . Page 4-4
- Para. 4.6—Planned Maintenance System (PMS) . . . . . Page 4-4
- Para. 4.7—General Maintenance Instructions . . . . . Page 4-4

#### 4.2 SYSTEM CERTIFICATION AND RE-ENTRY CONTROL (REC)

The Lightweight Dive System (LWDS) MK 3 Mod 0 is a Naval Sea Systems Command (NAVSEA) certified diving life support system and must be maintained in accordance with certification. The scope of certification is defined in detail in NAVSEA T9592-AB-SPN-010, *Specifications for Construction Lightweight Dive System FY 89*. The certification boundaries for Configurations 2 and 3 encompass all the components shown in Figures 3-2 through 3-4, and Figure 4-1 defines the certification boundaries for Configuration 1. Note that the diesel engine (not shown) and the compressor up to the unloader valve are outside the certification boundaries.

SS500-HK-MMO-010



COMPONENT LEGEND

	PLUG VALVE		PRESSURE GAUGE		ANGLE SHUTOFF VALVE W/RELIEF
	BALL VALVE		REGULATOR MANUAL ADJUST		FILTER
	CHECK VALVE		SHUTOFF VALVE (NEEDLE)		PILOT VALVE
	RELIEF VALVE		ANGLE SHUTOFF VALVE (NEEDLE)		DIFFERENTIAL INDICATOR
	SELECTOR VALVE				

Figure 4-1. LWDS MK 3 Mod 0 Certification Boundaries, Configuration 1

## SS500-HK-MMO-010

Maintenance of certified equipment requires strict adherence to the controls and procedures outlined in the *U.S. Navy Diving and Manned Hyperbaric Systems Safety Certification Manual*, NAVSEA SS521-AA-MAN-010, and the *Continuation of Certification Handbook for U.S. Navy Diving Systems*, NAVSEA SS521-AB-HBK-010. Scheduled maintenance actions within the system certification boundaries shall be conducted in accordance with the *Standardized Diver Re-Entry Control (REC) Procedures* (approved by NAVSEA letter 3151 Ser 00C/4225, dated 23 October 1996) until the certification manual is updated. This handbook can be accessed on-line at <http://www.supsalv.org/pdf/reentry.pdf>. The following guidelines apply when performing scheduled maintenance on components within the certification boundaries:

- a. This maintenance involves certified equipment and applicable certification procedures, including re-entry control, must be followed. Re-entry control is a formal process that consists of implementing procedures and instructions that define access into a certified system, and the precautions that must be taken to maintain the system in an “as certified” condition. When a pressure boundary is opened or breached for any reason, a REC form is required to verify that the work was done completely and correctly. Detailed information about REC and certification procedures, including electronic copies of REC logs and forms, may be accessed on-line at <http://www.supsalv.org/pdf/reentry.pdf>.
- b. For the purpose of sustaining system certification, use only the renewable parts listed in the “Tools, Parts, Materials, Test Equipment” block on the Maintenance Requirement Cards (MRCs) associated with the PMS for this system (see paragraph 4.6).

### **4.3 RECORDKEEPING AND REPORTING PROCEDURES**

The recordkeeping and reporting procedures presented in this section are to be performed in addition to the REC procedures referenced in paragraph 4.2. Information regarding PMS recordkeeping and reporting can be found in the *Ships' Maintenance Material Management (3-M) Manual*, OPNAVINST 4790.4 series, which describes the general PMS provisions that cover departmental and user unit recordkeeping as well as Maintenance Index Pages (MIPs) and MRCs. The maintenance information in this manual is intended to supplement the procedures furnished in the PMS for the LWDS MK 3 Mod 0 (see paragraph 4.6). In case of conflicts, the PMS takes precedence. Discrepancies associated with the PMS should be reported immediately on a PMS Feedback Report, OPNAV 4790/7B. Maintenance discrepancies found in this manual should be reported in accordance with the guidelines provided in the Foreword to this manual. Failure analysis reporting is covered in Chapter 2.

A logbook is used to record equipment use and maintenance performed on all major assemblies of the LWDS. Usage and maintenance data shall be recorded in the logbook to ensure continuance of certification.

### **4.4 GENERAL SAFETY REQUIREMENTS**

In addition to the safety precautions prescribed in this manual, maintenance shall be performed in accordance with the following instructions, as appropriate. Forces afloat must comply with

## SS500-HK-MMO-010

the *Navy Occupational Safety and Health (NAVOSH) Program Manual for Forces Afloat*, OPNAVINST 5100.19 series. Shore activities must comply with the *Navy Occupational Safety and Health Program Manual*, OPNAVINST 5100.23 series.

#### **4.5 MAINTENANCE CONCEPT**

The LWDS MK 3 Mod 0 maintenance concept is based on the U.S. Navy PMS, which classifies maintenance into two categories—scheduled and unscheduled.

**4.5.1 SCHEDULED MAINTENANCE.** Scheduled maintenance includes primarily preventive or replenishment actions to ensure reliable system operation. Scheduled maintenance requirements that are part of operational procedures, such as mission equipment preparation, are also described in Chapter 2, *Operation*. All scheduled maintenance (such as inspection, cleaning, lubrication, parts replacement, and calibration) shall be performed by qualified LWDS personnel.

**4.5.2 UNSCHEDULED MAINTENANCE.** Unscheduled (corrective) maintenance includes the actions required to locate equipment faults and correct failures or performance degradations. Unscheduled maintenance (such as troubleshooting, repair, and certain replacement procedures) is normally performed by maintenance technicians trained in LWDS service requirements. Unscheduled maintenance actions are described in Chapter 5, *Troubleshooting*, and Chapter 6, *Corrective Maintenance*.

#### **4.6 PLANNED MAINTENANCE SYSTEM (PMS)**

Preventive maintenance actions and performance tests are accomplished on a scheduled or situation-related basis. Maintenance procedures not performed during predrive or postdrive procedures are contained in the LWDS PMS, which consists of Maintenance Index Pages (MIPs) and Maintenance Requirement Cards (MRCs). All scheduled maintenance for the LWDS is to be conducted in accordance with **MIP 5921/170** and **MIP 5921/171**. MIP 5921/170 covers the Diesel Engine (Lister Model LV2) and Compressor (Atlas Copco Model LT8), and MIP 5921/171 covers the Diver's Compressed HP Air Flasks, Cylinders, Separators, Filters, Piping, Valves, and Gages. The MIPs provide a summary of the maintenance actions found on each of the MRCs and include the periodicity codes that indicate the frequency of the required maintenance (see Table 4-1 for typical periodicity codes). All LWDS MRCs are within the scope of certification and are periodically updated via regular U.S. Navy PMS channels. Predrive and postdrive maintenance procedures are provided in checklist form in Appendix A.

#### **4.7 GENERAL MAINTENANCE INSTRUCTIONS**

**4.7.1 TOOLS, SUPPLIES, AND TEST EQUIPMENT.** The tools, supplies, and test equipment required for each scheduled maintenance action in the PMS are listed on the individual MRCs. The tools and consumable supplies required to perform corrective maintenance on the LWDS MK 3 Mod 0 are listed in Chapter 6.

## SS500-HK-MMO-010

Table 4-1. Periodicity Codes

Code	Periodicity
<b>CALENDAR</b>	
M	Monthly
Q	Quarterly
S	Semiannually
A	Annually
36M	Each 36 months
72M	Each 72 months
<b>NON-CALENDAR</b>	
R	Situation requirement
<b>INACTIVE EQUIPMENT MAINTENANCE</b>	
LU	Lay-up maintenance
PM	Periodic maintenance
SU	Start-up maintenance

**WARNINGS**

**Repair or replace worn or damaged parts immediately with authorized replacement parts. Failure of a system component during a dive may result in injury or death to the diver.**

**DO NOT DISASSEMBLE COMPONENTS NOR LOOSEN OR TIGHTEN FITTINGS WHILE THE SYSTEM IS UNDER PRESSURE. Prior to performing maintenance, ensure HP air supply has been shut down and all pressure has been vented from the system. Exposure to escaping HP air may result in serious injury or death to personnel.**

**4.7.2 DISASSEMBLY AND REPLACEMENT OF PARTS.** Disassemble equipment only to the level necessary to complete the scheduled maintenance action (e.g., cleaning, inspection, repair). Procedures authorized at the user unit organizational level are specified in the MRCs. To maintain system certification, ensure all replacement parts used are approved for use with the LWDS (authorized replacement parts are listed in Chapter 7 and in Allowance Parts List (APL) 990010127 for the LWDS MK 3 Mod 0). Ensure proper tag-out procedures are conducted prior to performing maintenance.

## SS500-HK-MMO-010

**WARNINGS**

**Cleanliness is imperative in maintaining and handling the LWDS MK 3 Mod 0. All tools and parts must be kept free of oil, grease, rust, or other contamination. Foreign substances within an assembly may result in equipment failure and possible injury or death to the diver.**

**Do not use freon, bleach, or trichloroethylene for cleaning. These agents are toxic and usage may result in injury or death to personnel and damage to equipment.**

**Do not use Trisodium Phosphate (TSP) to clean aluminum or copper components. Use may result in equipment failure and personnel injury or death.**

**4.7.3 CLEANING AND LEAK DETECTION.** "Clean" is defined as free of all loose scale, rust, grit, filings, dirt, and other foreign substances when viewed by the unaided eye; and free of oil, grease, and other organic materials. It is vitally important to keep the work area and parts clean during maintenance of breathing air systems and equipment. This section covers cleaning of the breathing air system components, precleaning or leak detection using a Nonionic Detergent (NID) solution, and final cleaning with NID or Navy Oxygen Cleaner (NOC).

**4.7.3.1 Cleaning Breathing Air System Components.** Breathing air systems must be cleaned as components, or cleaned following assembly and prior to being placed into service. Cleaning of the breathing air system shall be performed in strict accordance with MIL-STD-1622 or better, using a cleaning procedure that has been approved by Naval Sea Systems Command (NAVSEA). Additional information on diver life support system cleaning can be obtained on-line at <http://www.supsalv.org> under Topside Tech Notes, Volume VI (see Table 1-3 for detailed access instructions).

**4.7.3.2 Precleaning and Leak Detection.** To avoid introducing contaminants into connections or joints that need to be opened for maintenance, clean the affected parts with a soft bristle brush and a cleaning solution prepared by mixing 1 teaspoon of general-purpose Nonionic Detergent (NID) (MIL-D-16791E, Type I, NSN 7930-00-282-9699) with 1 gallon of warm fresh water. Rinse the cleaned parts with clean fresh water and wipe dry with a clean cloth or blow dry. Once the joints or connections have been opened, maintain cleanliness by capping or plugging all open ports, or by bagging all exposed components prior to performing maintenance. The NID solution can also be used as a leak detection solution.

## SS500-HK-MMO-010

**CAUTION**

Components cleaned with NOC shall be rinsed thoroughly before the NOC has a chance to dry. Dry NOC deposits are extremely difficult to remove.

**4.7.3.3 Final Cleaning.** Final cleaning of breathing air system components may be accomplished with the NID solution referenced in paragraph 4.7.3.2 or with Navy Oxygen Cleaner (NOC). A process instruction for cleaning diving system air components with NOC is available on-line at <http://www.supsalv.org> (see Table 1-3 for detailed access instructions).

**4.7.4 TEFLON® TAPE.** During disassembly of taped fittings, use care to keep parts clean and avoid introducing contaminants, foreign matter, or tape particles into lines or valves. When applying Teflon® tape to male fittings, use two turns of the tape and leave three threads free to allow engagement when mating parts.

**4.7.5 LUBRICANTS.** Use only those lubricants authorized by the MRCs. Apply lubricants sparingly to avoid clogging or otherwise accumulating foreign substances.

**4.7.6 O-RINGS AND PACKINGS.** If possible, visually inspect existing O-rings and packings to avoid unnecessary disassembly that might result in damage or undue wear. Unless otherwise directed, cut and discard used O-rings. Damaged O-rings should always be cut and discarded. When a maintenance procedure requires that an O-ring be removed and permits its re-use, comply with the removal, inspection, cleaning, lubrication, and installation procedures presented below. Installation of new O-rings is covered in paragraph 4.7.6.4.

**CAUTION**

Do not use metal screwdrivers or metal picks to remove O-rings. To avoid damage to O-ring groove, whenever possible remove O-rings using fingers only.

**4.7.6.1 Removal.** Whenever possible, remove O-rings using the fingers only. When an O-ring is seated so tightly in its groove that it cannot be removed in this manner, use a non-metallic O-ring removal tool. This method prevents scratching the O-ring groove, which may cause leakage or premature seal failure.

**4.7.6.2 Inspection.** Inspect all removed O-rings for deformities or compression set, hardening or brittleness, nicks or cuts, pits or blisters, or any other sign of damage. Cut and discard damaged O-rings and replace them with new ones.

**4.7.6.3 Cleaning and Lubrication.** Ensuring strict cleanliness and proper lubrication is extremely important during O-ring installation. Comply with the following instructions to ensure proper installation:

- a. **Ensure all parts are clean throughout the assembly procedure.** Loose particles or dirt in O-ring groove can cause leaks in seal and damage to O-ring, reducing its life.



## SS500-HK-MMO-010

During cleaning of equipment, carefully clean O-ring grooves using soft bristle brush and NID solution prepared in accordance with paragraph 4.7.3.2.

- b. **Clean used O-rings before reinstalling them.** Place O-rings in a cleaning basin, cover with NID solution prepared in accordance with paragraph 4.7.3.2, and brush gently with soft bristle brush. Rinse cleaned O-rings with fresh water and wipe with clean, lint-free cloths. Allow O-rings to air dry.
- c. Before assembly, lubricate O-ring and all parts that contact it. **Apply approved lubricant sparingly** since excess lubricant can foul downstream filters and other components.

**WARNING**

**Ensure O-rings are in good condition before installation. Failure of an O-ring in any component may result in equipment damage, mission abort, or diver injury or death.**

**4.7.6.4 Installation.** Comply with the following procedure to ensure proper installation of new O-rings or reinstallation of previously used O-rings (if re-use is permitted and the procedures in paragraphs 4.7.6.1 through 4.7.6.3 have been followed):

- a. Ensure that new O-rings are of proper size and material and have been lubricated in accordance with step c of paragraph 4.7.6.3.
- b. Do not overstretch O-ring during assembly. Stretch O-rings only as much as necessary for installation. Diameter stretch during installation should not exceed 5 percent; overstretching may damage O-ring.
- c. Ensure O-ring is not twisted in its groove. Twisting occurs easily during installation of large O-rings with a relatively small cross-sectional diameter.
- d. Do not force O-ring over corners, threads, keyways, slots, splines, ports, or other sharp edges. Use thimbles, supports, cones, or similar devices to prevent O-ring from coming in contact with sharp edges.
- e. Ensure O-ring is not pinched at groove corners while closing or assembling components sealed by O-rings.
- f. When assembling component, avoid any rotating or twisting movements that may bunch, cut, or tear O-ring material.

SS500-HK-MMO-010

## CHAPTER 5

### TROUBLESHOOTING

#### 5.1 INTRODUCTION

This chapter provides procedures for locating and correcting Lightweight Dive System (LWDS) MK 3 Mod 0 equipment faults that can cause operational malfunctions. These troubleshooting procedures are intended primarily for use in the diving unit's shop, diving locker, or work site.

#### NOTE

This manual, written for user organizational-level maintenance, cannot possibly list all malfunctions that may occur, nor all tests, inspections, and corrective actions. If a specific malfunction is not listed or cannot be corrected by the listed maintenance actions, notify the immediate supervisor.

#### 5.2 TROUBLESHOOTING ANALYSIS

Troubleshooting involves a step-by-step fault isolation process. Ordinarily an equipment fault is indicated by an observed symptom or malfunction. The objective is to locate the cause and take corrective action. The most common and easily corrected causes of the fault are investigated first. A fault directory chart can assist in this process. The fault isolation index (Table 5-1) provides a listing of the LWDS major assemblies and their corresponding fault directories (Tables 5-2 through 5-6), with references to related operation and maintenance procedures located in this manual. Each fault directory lists possible malfunction symptoms, probable causes, suggested remedies, and specific references to associated maintenance procedures to correct the malfunction.

Maintenance remedies listed as LOCAL REPAIR indicate a repair condition that may be beyond the unit's repair capability. Maintenance repairs beyond the capability of the unit should be procured from any qualified Intermediate Maintenance Activity (IMA), manufacturer, or distributor, or from Coastal Systems Station, Code E53 (see contact information below). A list of equipment manufacturers and suppliers for the LWDS MK 3 Mod 0 is provided in Table 7-2.

COMMANDING OFFICER  
COASTAL SYSTEMS STATION  
DAHLGREN DIVISION, CODE E53  
6703 WEST HIGHWAY 98  
PANAMA CITY FL 32407-7001  
DSN 436-5873 -OR- COMMERCIAL (850) 235-5873

## SS500-HK-MMO-010

**Table 5-1. Fault Isolation Index**

<b>Major Assembly</b>	<b>Fault Directory (Chapter 5)</b>	<b>Test/Maintenance Procedures (Chapter 6)</b>
Control Console Assembly	Table 5-6	Paragraph 6.8.5
Diesel-Compressor Assembly Diesel Engine Air Compressor	Table 5-2 Table 5-3	Paragraph 6.8.1 Paragraph 6.8.2
Primary HP Air Supply	Table 5-4	Paragraph 6.8.3
Roof Rack Assembly	Table 5-4	Paragraph 6.8.3
Secondary HP Air Supply	Table 5-4	Paragraph 6.8.3
Volume Tank Assembly	Table 5-5	Paragraph 6.8.4

## SS500-HK-MMO-010

**Table 5-2. Diesel Engine Fault Directory**

Symptom	Probable Cause	Remedy	Corrective Action Reference
<b>NOTE</b>			
All Maintenance Requirement Card (MRC) references in this table are associated with Maintenance Index Page (MIP) <b>5921/170</b> , Diesel Engine (Lister Model LV2) / Compressor (Atlas Copco Model LT8).			
1. Engine difficult to turn (decompressed)	a. Lubricating oil too heavy	a. Drain sump and refill with correct oil.	MRC 8YHH
	b. Incorrect engine decompressor clearance	b. Readjust.	Para. 6.3.8
	c. Load not disconnected from the engine	c. Ensure compressor pilot valve and diesel decompressor are in the unloaded position and hoses are bled down.	Para. 6.3.9
2. Engine difficult to start	a. Insufficient fuel	a. Fill tank and bleed system.	MRC 8YHF
	b. Stop/run cable positioned incorrectly	b. Push cable down to starting position.	---
	c. Air filter or exhaust blocked/clogged	c. Replace air filter element or remove obstruction.	MRC 8YHL
	d. Valve sticking	d. LOCAL REPAIR	---
	e. Air in fuel system	e. Check fuel lines and tighten connections; bleed system.	MRC 8YHF
	f. Defective fuel pump	f. Remove and replace fuel pump.	Para. 6.8.1.2
	g. Faulty fuel injector	g. Remove and replace fuel injector.	Para. 6.8.1.3 MRC 8YHR
3. Failure to obtain normal speed	a. Engine started under load	a. Reduce load on engine by unloading the compressor until normal speed is obtained.	---
	b. Fuel system not primed	b. Bleed and prime.	MRC 8YHF
	c. Fuel injection retarded	c. Remove and replace fuel injector.	Para. 6.8.1.3 MRC 8YHR
4. Loss of power	a. Incorrect fuel	a. Drain tank and refill with correct diesel fuel.	MRC 8YHF
	b. Clogged air filter	b. Remove and replace air filter element.	MRC 8YHL
	c. Clogged fuel filter	c. Remove and replace fuel filter element.	MRC 8YHH

## SS500-HK-MMO-010

Table 5-2. Diesel Engine Fault Directory—Continued

Symptom	Probable Cause	Remedy	Corrective Action Reference
4. Loss of power—continued	d. Fuel injector not functioning properly	d. Remove and replace fuel injector.	Para. 6.8.1.3 MRC 8YHR
	e. Fuel pump not operating correctly	e. Remove and replace fuel pump.	Para. 6.8.1.2
	f. Incorrect valve to rocker clearance	f. Adjust.	Para. 6.3.7 MRC 8YHG
	g. Clogged exhaust	g. Remove obstruction.	---
	h. Loose injector	h. Torque injector clamp capscrew to 186 in-lb.	Para. 6.8.1.3
5. Erratic or uneven running	a. Air in fuel system	a. Check fuel lines and tighten connections; bleed system.	MRC 8YHF
	b. Incorrect fuel pump timing	b. Adjust timing.	Para. 6.3.4
	c. Faulty fuel injector	c. Remove and replace fuel injector.	Para. 6.8.1.3 MRC 8YHR
	d. Loose fuel injector	d. Torque injector clamp capscrew to 186 in-lb.	Para. 6.8.1.3
6. Knocking/vibration	a. Incorrect fuel	a. Drain tank and refill with correct diesel fuel.	MRC 8YHF
	b. Engine loose on mountings	b. Tighten mounting bolts.	MRC 8YHH
	c. Air in fuel system	c. Check fuel lines and tighten connections; bleed system.	MRC 8YHF
	d. Worn bearings	d. LOCAL REPAIR	---
	e. Insufficient clearance between piston and cylinder head	e. LOCAL REPAIR	---
	f. Flywheel loose	f. Tighten.	MRC 8YHH
	g. Excessive carbon deposit on piston	g. LOCAL REPAIR	---
	h. Valve sticking in guide	h. LOCAL REPAIR	---
	i. Misaligned/loose drive belt	i. Adjust drive belt and align pulleys.	Para. 6.3.1 Para. 6.3.2 MRC 8YHH

## SS500-HK-MMO-010

**Table 5-2. Diesel Engine Fault Directory—Continued**

Symptom	Probable Cause	Remedy	Corrective Action Reference
7. Smoky exhaust (black)	a. Engine overloaded	a. Check stopping control setting and check diesel engine speed.	Para. 6.3.3
	b. Air filter clogged	b. Remove and replace air filter element.	MRC 8YHL
	c. Fuel injector nozzle dirty	c. Clean nozzle.	MRC 8YHR
	d. Incorrect fuel	d. Drain tank and refill with correct diesel fuel.	MRC 8YHF
	e. Improperly adjusted valves	e. Adjust valve to rocker clearance.	Para. 6.3.7 MRC 8YHG
8. Smoky exhaust (blue)	a. Piston rings worn	a. LOCAL REPAIR	---
	b. Cylinder bore worn	b. LOCAL REPAIR	---
9. Engine stops	a. Insufficient fuel	a. Fill tank and bleed system.	MRC 8YHF
	b. Air in fuel system	b. Check fuel lines and tighten connections; bleed system.	MRC 8YHF
	c. Lift pump failure	c. Disconnect outlet of lift pump; crank engine and ensure fuel flow.	Para. 6.3.4
	d. Dirt in fuel injector or fuel system	d. Disconnect fuel injectors at diesel head; crank engine and ensure fuel flow.	MRC 8YHR
	e. Water in fuel system	e. Drain and flush tank, fill with correct diesel fuel, and bleed system.	MRC 8YHF
10. High oil consumption	Valve guides worn	LOCAL REPAIR	---
11. Engine overheating	a. Insufficient lubricating oil	a. Check oil level.	MRC 8YHL
	b. Engine overloaded	b. Reduce load.	---
	c. Cooling air is being recirculated	c. Ensure cooling air inlet and outlet are not obstructed.	MRC 8YHF
	d. Air filter or exhaust blocked/clogged	d. Replace air filter element or remove obstruction.	MRC 8YHL
	e. Fuel Injection retarded	e. Remove and replace fuel injectors.	Para. 6.8.1.3 MRC 8YHR

## SS500-HK-MMO-010

**Table 5-3. Air Compressor Fault Directory**

Symptom	Probable Cause	Remedy	Corrective Action Reference
<b>NOTE</b>			
Except as noted, all MRCs in this table are associated with MIP <b>5921/170</b> , Diesel Engine (Lister Model LV2) / Compressor (Atlas Copco Model LT8).			
1. Insufficient air pressure	a. Low pressure gauge (ALP-G406) defective	a. Check; replace if necessary.	Para. 6.8.2.9
	b. Compressor or snorkel intake air filter clogged	b. Service filter.	MRC 8YHK
	c. Air leakage	c. Pressurize system, shut down diesel engine, and check system for leaks. Repair as necessary.	MIP <b>5921/171</b> MRC 8YJG
	d. Pilot valve (ALP-V403) incorrectly set	d. Adjust pilot valve to increase unload pressure.	Para. 6.3.9
	e. Air consumption exceeds capacity of compressor	e. Pressurize system, shut down diesel engine, and check system for leaks. Repair as necessary.	MIP <b>5921/171</b> MRC 8YJG
	f. Damaged valve(s)	f. LOCAL REPAIR	---
	g. Unloader plunger jammed or unloader valve or spring broken	g. Inspect unloader assembly; replace parts as necessary.	Para. 6.8.2.3 MRC 8YHQ
2. Unit does not load	Unloader plunger jammed	Inspect unloader assembly; replace parts as necessary.	Para. 6.8.2.3 MRC 8YHQ
3. Pressure rises above maximum and causes relief valve to blow	a. Pilot valve (ALP-V403) incorrectly set or not functioning properly	a. Reset or remove and replace pilot valve.	Para. 6.3.9 Para. 6.8.2.7 MRC 8YHP
	b. Unloader plunger jammed	b. Inspect unloader assembly; replace parts as necessary.	Para. 6.8.2.3 MRC 8YHQ
4. Loading periods too short	Pilot valve (ALP-V403) incorrectly set	Increase pressure difference.	Para. 6.3.9
5. High oil consumption	a. Oil level too high	a. Check oil level. Drain excess oil; do not overfill.	MRC 8YHK MRC 8YHJ
	b. Vent valve malfunctioning	b. Remove and replace vent valve.	Para. 6.8.2.4 MRC 8YHE
	c. Piston ring(s) worn or broken	c. LOCAL REPAIR	---

SS500-HK-MMO-010

**Table 5-3. Air Compressor Fault Directory—Continued**

Symptom	Probable Cause	Remedy	Corrective Action Reference
6. Loading periods too long (long period between cycling, or continuous cycling)	a. Air leakage	a. Pressurize system, shut down diesel engine, and check system for leaks. Repair as necessary.	MIP <b>5921/171</b> MRC 8YJG
	b. Excessive air consumption	b. Decrease consumption.	Para. 6.3.9
	c. Compressor not in optimum condition	c. LOCAL REPAIR: Have compressor inspected.	---
	d. Sticking or damaged valves	d. LOCAL REPAIR	---



## SS500-HK-MMO-010

**Table 5-4. HP Air Supply and Roof Rack Assembly Fault Directory**

Symptom	Probable Cause	Remedy	Corrective Action Reference
<b>PRIMARY AND SECONDARY HP AIR SUPPLIES</b>			
1. No leakage, but pressure gauge shows low or high pressure	Pressure indication needle stuck	Cross-check gauges on manifolds, roof rack assembly, and volume tank assembly; replace pressure gauges if necessary.	Para. 6.8.3.4
2. Leakage (other than during filling)	a. Loosely installed components	a. Check torque values.	Table 6-4
	b. Damaged O-ring(s)	b. Discard and replace damaged O-ring(s).	Para. 4.7.6 Para. 6.8.3
	c. Damaged Teflon® seat on hose	c. Replace softseat.	Para. 6.8.3.2 Para. 6.8.3.3
3. Leakage (during filling)	Damaged hose	Remove and replace hose assembly.	<b>MIP 5921/033</b>
4. Pressure gauge indicates improper air supply pressure	Bourdon tube clogged or failed	Cross-check with another gauge; remove and replace gauge if necessary.	Para. 6.8.3.4
5. Gauge isolation valve unable to isolate air flow to corresponding gauge	Debris build-up on valve seat	Remove and replace valve.	Para. 6.8.5.2 Para. 6.8.5.8
<b>ROOF RACK ASSEMBLY</b>			
1. Noticeable air loss from roof rack assembly	a. Contamination build-up on relief valve internal seat	a. Remove and replace relief valve (AHP-V603).	Para. 6.8.3.6
	b. Internal failure	b. Remove and replace relief valve (AHP-V603).	Para. 6.8.3.6
2. Leakage; slow air loss from roof rack assembly	a. O-ring failure	a. Discard and replace O-ring.	Para. 4.7.6 Para. 6.8.3
	b. Loose fittings	b. Tighten fittings.	---
	c. Cracked weld	c. LOCAL REPAIR	---
3. Roof rack charge inlet valve (AHP-V604) unable to supply or shut off air to flask racks	a. Handle broken	a. Remove and replace handle.	6.8.3.7
	b. Internal packing failure	b. Remove and replace valve. Send defective valve for LOCAL REPAIR.	6.8.3.7

## SS500-HK-MMO-010

**Table 5-5. Volume Tank Assembly Fault Directory**

Symptom	Probable Cause	Remedy	Corrective Action Reference
<b>NOTE</b> Except as noted, all MRCs in this table are associated with MIP <b>5921/171</b> , Divers Compressed HP Air Flasks, Cylinders, Separators, Filters, Piping, Valves, Gages.			
1. Loss of air pressure	a. Loss of air pressure through interconnecting fittings	a. Inspect for leaks. Tighten fittings or repair as required.	---
	b. Volume tank drain valve open	b. Close drain valve.	---
	c. Filter drain valve open	c. Close drain valve.	---
	d. Safety relief valve (ALP-V207, ALP-V211) leaking	d. Remove and replace relief valve.	Para. 6.8.4.6
2. Excessive moisture in air	Build-up of moisture in filter	Drain filters and volume tank.	---
3. Excessive air pressure in volume tank	Relief valve (ALP-V207, ALP-V211) not adjusted properly or jammed in closed position	Remove and replace or adjust relief valve.	Para. 6.8.4.6
4. Air flow from primary HP air supply impeded	Primary HP air supply filter clogged	Back-flush or remove and replace air filter element.	MRC 8YJF
5. Backflow of air from volume tank through compressor moisture separator	Damaged check valve (ALP-V206)	Remove and replace valve. Send defective valve for LOCAL REPAIR.	Para. 6.8.4.5
6. Air pressure build-up in volume tank assembly downstream of regulator	Internal failure of valve regulator (AHP-V201)	Remove and replace regulator.	Para. 6.8.4.1
7. Pressure gauge (AHP-G211, -G212) indicates improper air supply pressure	Bourdon tube clogged or failed	Cross-check with another gauge; remove and replace gauge if necessary.	Para. 6.8.4.8 Para. 6.8.4.9 MRC 8GSA
8. Gauge isolation valve (AHP-V202, ALP-V204) unable to isolate air flow to corresponding gauge	Debris build-up on valve seat	Remove and replace valve.	Para. 6.8.4.2 Para. 6.8.4.3

## SS500-HK-MMO-010

**Table 5-6. Control Console Assembly Fault Directory**

Symptom	Probable Cause	Remedy	Corrective Action Reference
1. Supply selector valve (ALP-V302) unable to select or shut off secondary or primary air supply	a. Handle broken	a. Remove and replace handle.	Para. 6.8.5.3
	b. Internal packing failure	b. Remove and replace valve. Send defective valve for LOCAL REPAIR.	Para. 6.8.5.3
2. HP IN gauge (AHP-G316) indicates improper pressure of secondary air supply	Bourdon tube clogged or failed	Cross-check with another gauge; remove and replace gauge if necessary.	Para. 6.8.5.10 MRC 8GSA
3. HP IN gauge isolation valve (AHP-V309) unable to isolate air flow to HP IN gauge (AHP-G316)	Debris build-up on valve seat	Remove and replace valve.	Para. 6.8.5.8
4. LP OUT gauge (ALP-G317) indicates improper pressure of LP supply	Bourdon tube clogged or failed	Remove and replace gauge.	Para. 6.8.5.9
5. LP OUT gauge isolation valve (ALP-V310) unable to isolate air flow to LP OUT gauge (ALP-G317)	a. Debris build-up on valve seat	a. Remove and replace valve.	Para. 6.8.5.2
	b. Internal packing failure	b. Remove and replace valve.	Para. 6.8.5.2
6. Air loss from control console assembly (secondary supply)	a. Contamination build-up on relief valve internal seat	a. Remove and replace relief valve (ALP-V308).	Para. 6.8.5.7
	b. Internal failure	b. Remove and replace relief valve (ALP-V308).	Para. 6.8.5.7
7. Air pressure build-up in control console assembly downstream of regulator	Internal failure of valve regulator (AHP-V307)	Remove and replace regulator.	Para. 6.8.5.6
8. LP supply gauge (ALP-G315) indicates improper pressure of diver air supply	Bourdon tube clogged or failed	Remove and replace gauge.	Para. 6.8.5.9
9. Diver depth gauge (ALP-G318, -G319, or -G320) indicates improper diver depth	Bourdon tube damage	Remove and replace gauge.	Para. 6.8.5.11

## SS500-HK-MMO-010

**Table 5-6. Control Console Assembly Fault Directory—Continued**

Symptom	Probable Cause	Remedy	Corrective Action Reference
10. Diver air supply valve (ALP-V304, -V305, or -V306) unable to supply air to respective diver or shut off air	a. Handle broken	a. Remove and replace handle.	Para. 6.8.5.5
	b. Internal packing failure	b. Remove and replace valve. Send defective valve for LOCAL REPAIR.	Para. 6.8.5.5
11. Pressure gauge isolation valve (ALP-V301, -V309, -V310) unable to isolate pressure gauge	a. Internal packing failure	a. Remove and replace valve.	Para. 6.8.5.2 Para. 6.8.5.8
	b. Debris build-up on valve seat	b. Remove and replace valve.	Para. 6.8.5.2 Para. 6.8.5.8
12. Check valve (ALP-V303) allows air to backflow into console	a. Internal spring break	a. Remove and replace valve. Send defective valve for LOCAL REPAIR.	Para. 6.8.5.4
	b. Check valve jammed open	b. Remove and replace valve. Send defective valve for LOCAL REPAIR.	Para. 6.8.5.4
13. Leakage; slow air loss from control console assembly	a. O-ring failure	a. Discard and replace O-ring.	Para. 4.7.6 Para. 6.8.5
	b. Loose fittings	b. Tighten fittings.	MRC 8YJA
	c. Cracked weld	c. LOCAL REPAIR	---

THIS PAGE INTENTIONALLY LEFT BLANK

SS500-HK-MMO-010

**CHAPTER 6****CORRECTIVE MAINTENANCE****WARNING**

**Properly performed corrective maintenance is essential to safe, dependable diving operations with the Lightweight Dive System (LWDS) MK 3 Mod 0. Omission or negligent performance of prescribed maintenance procedures could result in equipment failure and injury or death to personnel.**

**6.1 INTRODUCTION**

The corrective maintenance information presented in this chapter includes actions and procedures required to restore the Lightweight Dive System (LWDS) MK 3 Mod 0 equipment to a fully operational condition. The chapter presents both general repair information and specific maintenance repair procedures to facilitate the repair and replacement of inoperative parts or assemblies. The repair procedures are provided for personnel working at the user organizational level. Information in this chapter is arranged in the following sequence:

- Para. 6.2—Safety Requirements . . . . . Page 6-1
- Para. 6.3—Adjustments and Alignments . . . . . Page 6-2
- Para. 6.4—General Repair Information . . . . . Page 6-9
- Para. 6.5—Tools and Support Equipment . . . . . Page 6-10
- Para. 6.6—Torque Values . . . . . Page 6-11
- Para. 6.7—Consumable Supplies . . . . . Page 6-11
- Para. 6.8—Corrective Maintenance Procedures . . . . . Page 6-13

**6.2 SAFETY REQUIREMENTS**

Prior to conducting any corrective maintenance on the LWDS, maintenance personnel shall review and become thoroughly familiar with the general safety notices and precautions listed in the Safety Summary located at the front of this manual and with the specific warnings and cautions associated with the maintenance actions in this chapter. Also ensure that tag-out procedures, if applicable, are performed before conducting maintenance. The following warnings are applicable to all maintenance procedures presented in this chapter and shall be strictly followed to ensure the safety of all maintenance and diving personnel.

## SS500-HK-MMO-010

**WARNINGS**

**Before performing corrective maintenance on the LWDS, ensure that all pressure has been vented from the system. Accidental exposure to escaping high pressure air may result in injury or death to maintenance personnel.**

**Accomplish procedures in a clean environment. Contamination of the breathing air system may result in diver injury or death.**

**Discard and replace all O-rings as standard procedure while performing maintenance. Failure of an O-ring in any component may cause further damage to equipment, mission abort, or diver injury or death.**

**6.3 ADJUSTMENTS AND ALIGNMENTS**

Adjustment and alignment procedures for the LWDS include the following:

- Para. 6.3.1—Adjusting Drive Belt Tension . . . . . Page 6-2
- Para. 6.3.2—Aligning Pulleys . . . . . Page 6-3
- Para. 6.3.3—Adjusting Diesel Engine Speed . . . . . Page 6-3
- Para. 6.3.4—Setting Fuel Pump Timing . . . . . Page 6-4
- Para. 6.3.5—Setting Fuel Pump and Governor Distances . . . . . Page 6-4
- Para. 6.3.6—Setting Governor Speed Spring Tension . . . . . Page 6-5
- Para. 6.3.7—Adjusting Valve to Rocker Clearance . . . . . Page 6-5
- Para. 6.3.8—Adjusting Decompressors . . . . . Page 6-6
- Para. 6.3.9—Adjusting Compressor Pilot Valve (ALP-V403) . . . . . Page 6-7
- Para. 6.3.10—Adjusting Valve Packing . . . . . Page 6-8

**6.3.1 ADJUSTING DRIVE BELT TENSION.****NOTE**

The belt tension adjustment and pulley alignment procedures (paragraphs 6.3.1 and 6.3.2, respectively) are performed concurrently. When either procedure is performed, the other should also be performed to maintain proper equipment settings.

- a. Remove screws, nuts, and washers securing plastic belt guard. Remove belt guard and reinforcing straps.
- b. Loosen the four mounting bolts securing diesel engine to frame.

## SS500-HK-MMO-010

- c. Simultaneously tighten or loosen the two tensioning bolts to keep engine and compressor pulleys parallel until belt can be deflected 1/2 to 3/4 inch at center of span.
- d. Tighten the four diesel engine mounting bolts. Check alignment of engine and compressor pulleys in accordance with paragraph 6.3.2.

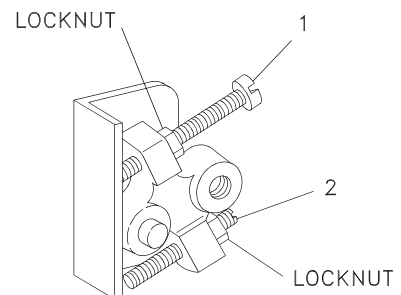
**6.3.2 ALIGNING PULLEYS.****NOTE**

The belt tension adjustment and pulley alignment procedures (paragraphs 6.3.1 and 6.3.2, respectively) are performed concurrently. When either procedure is performed, the other should also be performed to maintain proper equipment settings.

- a. Before proceeding, ensure drive belt tension has been adjusted in accordance with paragraph 6.3.1.
- b. Place straight edge along the two pulleys parallel to drive belt. If straight edge does not lie flush, loosen the four diesel engine mounting bolts, and rotate engine by tightening or loosening one belt tension adjustment bolt (usually bolt closest to drive pulley). Do not overtighten drive belt.
- c. If either pulley is loose or removed from shaft, move pulley in or out (as appropriate) by loosening the three sheave mounting bolts and sliding sheave mount in or out.
- d. Tighten the four diesel engine mounting bolts.
- e. Reinstall plastic belt guard and reinforcing straps. Reinstall screws, nuts, and washers securing belt guard.

**6.3.3 ADJUSTING DIESEL ENGINE SPEED.** The diesel engine speed is set correctly when the compressor runs at 1800 +0 / -25 revolutions per minute (rpm). The following procedure explains how to adjust the engine speed using the adjustment mechanism shown in Figure 6-1.

- a. Start diesel engine and run for 5 minutes to allow engine to reach operating temperature. Ensure compressor is loaded and system is at operating pressure.
- b. Open window on belt guard, and check compressor speed by pointing a strobe tachometer in window closest to compressor. Tachometer reading should be 1800 +0 / -25 rpm.



**Figure 6-1. Engine Speed Adjustment Mechanism**



## SS500-HK-MMO-010

- c. If compressor speed is not 1800 +0 / -25 rpm, shut down engine and adjust engine speed adjustment screws (1 and 2) by loosening both locknuts and then turning adjustment screws simultaneously. Turning screw (1) clockwise and screw (2) counterclockwise will increase speed. Reversing the procedure will decrease speed. Ensure distance between screw (2) and stop plate is at least 1/4 inch. After adjustment is made, tighten locknuts.
- d. Start engine and recheck compressor speed. If compressor speed is not in allowable range, repeat step c until compressor speed measures 1800 +0 / -25 rpm.

**6.3.4 SETTING FUEL PUMP TIMING.**

- a. Pull control lever upward to STOP position and release. Push control lever down to START position.
- b. Turn flywheel to firing position. While looking through timing hole in fan shroud, line up timing mark on flywheel with projecting arrow on fan shroud. Ensure both valves on cylinder are closed.
- c. Loosen lower nut on pump-to-injector fuel line (Figure 6-6, 2) while holding fuel pump delivery valve holder with wrench to prevent turning. Disconnect pump-to-injector fuel line from fuel pump and fuel injector.
- d. Remove delivery valve holder, delivery valve (Figure 6-5, 6), spring, and seat from fuel pump (4). If fuel flows from pump, turn crankshaft forward until flow stops.
- e. Install delivery valve holder without delivery valve (6), spring, or seat.
- f. Reconnect fuel supply, and set timing in accordance with the following:
  - (1) Turn crankshaft backward until fuel begins to flow and then turn slowly in same direction until flow stops.
  - (2) Blow fuel from top of delivery valve holder to ensure flow has stopped.
  - (3) Ensure firing mark on flywheel is in line with mark on fan shroud. If marks are not lined up, adjust shims (10, 11) below pump body (add shims to retard or remove shims to advance).
  - (4) When timing is correct, disconnect fuel supply in accordance with step c, remove delivery valve holder, and reinstall delivery valve (6), spring, and seat. Reconnect fuel supply.

**6.3.5 SETTING FUEL PUMP AND GOVERNOR DISTANCES.**

- a. Remove fuel pump inspection doors from crankshaft.
- b. Pull control lever upward to STOP position and release. Push control lever down to START position.

## SS500-HK-MMO-010

- c. Tap the flywheel end of camshaft to take up any play.
- d. Check distance between governor lever and governor lever pivot. If necessary, add shims (Figure 6-5, 10, 11) until clearance is between 0.005 and 0.010 inch.
- e.
  - (1) Set distance between end of thrust sleeve and shoulder on camshaft to 0.197 inch by scribing mark 0.197 inch from shoulder and lining sleeve up with mark.
  - (2) Ensure calibration mark “B” on No. 1 fuel pump is in line with mark on center of fuel pump body, while distance between end of thrust sleeve and shoulder on camshaft is maintained.
  - (3) If necessary, adjust length of governor link by loosening locknuts holding governor lever assembly, ensuring chamfered spacer stays in place.
  - (4) Ensure calibration marks “B” on both fuel pumps are in line. If necessary, loosen governor link and rotate pump.
- f. Put automatic excess fuel device in RUN by pulling engine start and stop control to STOP and then pushing down to START. Move governor lever away from camshaft until automatic excess fuel device clicks into RUN.
- g. Loosen control plate retaining screw. Insert 0.024-inch (0.6mm) feeler gauge and rotate plate until fuel pump calibration marks line up. Tighten screw and remove feeler gauge.
- h. Reinstall fuel pump inspection doors.

**6.3.6 SETTING GOVERNOR SPEED SPRING TENSION.** The speed control lever has two adjusting screws—one on the right and one on the left. In a constant-speed engine, the left-hand screw has no function. To increase the idling speed on a constant-speed engine, turn the right-hand screw clockwise. See pages 60-61 of Lister-Petter Parts List for parts location.

**CAUTION**

To avoid damage to valves, valve clearances must be maintained correctly.

**6.3.7 ADJUSTING VALVE TO ROCKER CLEARANCE.** In overhauled engines, valves seat more rapidly during the first 500 hours of running time, resulting in valve to rocker clearances needing to be checked more frequently. Each cylinder head contains an inlet and an exhaust valve with a rocker lever for each; therefore, a total of four valve clearances must be checked for the proper adjustment. Valve to rocker clearances should be checked initially after the engine has run for 25 hours, then every 250 hours until clearances remain constant, and thereafter every 1,000 hours. Valve clearance is dependent on engine speed and must be set with the engine cold. Table 6-1 shows the valve to rocker clearances with the corresponding piston set at Top Dead Center (TDC) of the firing stroke (both valves in the cylinder head closed).

## SS500-HK-MMO-010

The callouts in the following procedure refer to Figure 1 in the Lister-Petter Operators Handbook.

- a. Remove cylinder head covers in accordance with paragraph 6.8.1.1. Turn engine until piston is at TDC position of firing stroke (both valves closed).
- b. While holding rocker lever adjusting screw (B) in place with a screwdriver, loosen locknut (A) and then turn adjusting screw until correct clearance is obtained (see Table 6-1). Again holding screw securely in place with a screwdriver, tighten locknut.

**Table 6-1. Valve to Rocker Clearances**

Speed	Valve Type	GO	NO GO
Up to 3,000 rpm	Inlet	0.004 inch	0.006 inch
	Exhaust	0.004 inch	0.006 inch
3,001 rpm and above	Inlet	0.002 inch	0.004 inch
	Exhaust	0.005 inch	0.007 inch

- c. Recheck valve to rocker clearance. If clearance is GO, torque locknut (A) to 78 in-lb. If clearance is NO GO, repeat steps b and c until recheck clearance is GO.
- d. Repeat procedure until all four valve clearances have been adjusted.
- e. If required, perform decompressor adjustment in accordance with paragraph 6.3.8. If decompressor adjustment is not required, reinstall cylinder head covers in accordance with paragraph 6.8.1.1.

**6.3.8 ADJUSTING DECOMPRESSORS.** The inlet and exhaust valve clearances should be as shown in the GO column in Table 6-1 prior to adjusting the decompressor levers, which are spring-loaded toward the exhaust valve rocker lever in each cylinder head. Although the callouts in the following procedure refer to Figure 2 in the Lister-Petter Operators Handbook, the actual configuration is slightly different from that shown. A spring and a plain washer (or shim) are located on the shaft between the adjusting screw (B) and the wall of the cylinder head, and an O-ring installed outside the cylinder head prevents oil seepage along the shaft.

- a. With cylinder head covers removed (paragraph 6.8.1.1), turn engine until piston is at TDC position of firing stroke (both valves closed).
- b. Turn decompressor adjusting screw (B) in clockwise direction just until valve rocker lever begins to depress exhaust valve, then turn adjusting screw one full turn beyond that. Adjusting screw requires a torque load of 6 in-lb to turn.
- c. Repeat procedure for other cylinder.
- d. Reinstall cylinder head covers in accordance with paragraph 6.8.1.1.

## SS500-HK-MMO-010

**6.3.9 ADJUSTING COMPRESSOR PILOT VALVE (ALP-V403).** (Refer to Figure 6-2)

- a. Volume tank assembly must vent air to atmosphere to allow adjustment of pilot valve (ALP-V403). Ensure no hose is connected to volume tank outlet and that dust cap is removed. Open volume tank **LP AIR OUT** valve (ALP-V210) approximately 1/4 turn or until compressor cycles at approximate 1-minute intervals.
- b. Connect compressor to volume tank assembly and start diesel engine. Load compressor to charge volume tank.

**WARNING**

**To avoid injury or death to personnel, never disassemble pilot valve while pressurized; adjust 1-2 turns. Load and unload pressures are  $145 \pm 5$  psi and  $165 \pm 5$  psi, respectively. Deviation from these pressure settings must have documented approval by supervisor before diving system.**

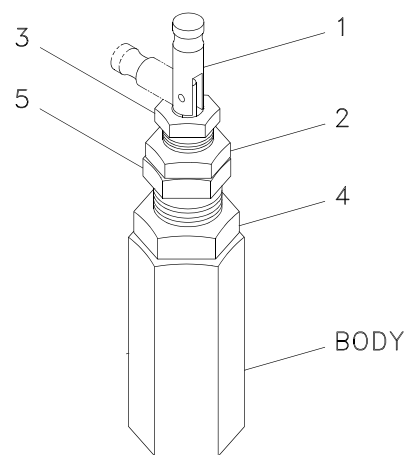
- c. Observe and note pressures where compressor loads and unloads. Load pressure should be  $145 \pm 5$  pounds per square inch (psi) and unload pressure should be  $165 \pm 5$  psi, as observed on volume tank **TANK PRESSURE** gauge (ALP-G212).

**NOTE**

Compressor is unloaded when rpm increases, air flows from pilot valve stem, and volume tank gauge pressure drops.

- d. If pressure is not adequate (as defined in step c), adjust valve as follows:

- (1) Begin by checking unload pressure (maximum pressure obtained in a cycle) on volume tank **TANK PRESSURE** gauge (ALP-G212); pressure should be  $165 \pm 5$  psi. If unload pressure is not correct, flip toggle (1) to vertical position and slightly loosen unload adjustment locknut (2). Unload pressure is adjusted by turning unload adjuster screw (3) clockwise to increase or counterclockwise to decrease. When desired adjustment is achieved, hold unload adjuster screw (3) and tighten adjustment locknut (2). Recheck unload pressure. If still not within limits, repeat procedure.



**Figure 6-2. Pilot Valve (ALP-V403)**

## SS500-HK-MMO-010

- (2) Changing differential pressure will affect load pressure (minimum pressure obtained in cycle). Load pressure is read from volume tank **TANK PRESSURE** gauge (ALP-G212); if pressure is not  $145 \pm 5$  psi, adjust differential pressure by slightly loosening differential locknut (4) and adjusting differential adjustment cap (5) clockwise to increase differential pressure (lower load pressure) or counterclockwise to decrease differential pressure (increase load pressure). When adjusted, tighten differential locknut (4) while holding differential adjustment cap (5). Flip toggle (1) to horizontal position and check operation of pilot valve.

**6.3.10 ADJUSTING VALVE PACKING.** The valves addressed in this section contain packing that will occasionally require adjustment to allow the valve to operate correctly. If the packing is too loose or too tight, the valve may leak or function improperly and must be adjusted in accordance with one of the procedures shown below. The introduction for each procedure specifies the valves that can be adjusted using that particular procedure.

- a. Adjust valve packing on **ALP-V401** and **ALP-V405** in accordance with the following procedure. Refer to Figure 7-23 as required for location of components.

- (1) Remove setscrew from valve handle, and remove handle from valve stem.

**NOTE**

Ensure packing is not overtightened. Proper adjustment of valve packing will place moderate drag on valve operation.

- (2) Slide packing adjustment tool (found in tool kit provided with system) over valve stem and insert prongs into the two holes located at bottom of stem. Using 9/16-inch wrench, turn packing adjustment tool slightly (1/16 turn only). Turning tool counterclockwise will loosen packing and turning it clockwise will tighten packing.

- (3) Reinstall handle on valve stem and secure with setscrew.

- (4) Apply pressure to valve and test for leaks using NID solution prepared in accordance with paragraph 4.7.3.2. If necessary, repeat entire procedure until valve is operating properly and a leak-tight seal is achieved at valve stem and ports.

- b. Adjust valve packing on **AHP-V202** and **AHP-V309** in accordance with the following procedure. Refer to Figure 7-26 as required for location of components.

- (1) If necessary to remove handle to adjust packing, use an Allen wrench to remove setscrew. Remove pin from handle, and remove handle from valve stem.

- (2) Using two wrenches, remove locknut from valve by positioning one wrench on the locknut and the other on the panel nut and turning locknut counterclockwise.

- (3) Using adjustable wrench, turn packing bolt slightly (1/16 turn only) in a clockwise direction to compress packing against valve stem or counterclockwise to loosen packing.

## SS500-HK-MMO-010

- (4) If handle was removed in step (1), place handle on valve stem and insert handle pin. Using an Allen wrench, screw setscrew into handle to secure pin.
  - (5) Apply pressure to valve and test for leaks using NID solution prepared in accordance with paragraph 4.7.3.2. If necessary, repeat entire procedure until valve is operating properly and a leak-tight seal is achieved at valve stem and ports.
- c. Adjust valve packing on **ALP-V210, ALP-V302, ALP-V304, ALP-V305, and ALP-V306** in accordance with the following procedure. Refer to Figures 7-21 and 7-22 for location of components.
- (1) Using an Allen wrench, remove setscrew from handle. Carefully remove handle and handle stop insert (if supplied) from valve stem.
  - (2) Place 5/8-inch or adjustable wrench against flats located on base of valve stem. Turn valve stem slightly (1/16 turn only) in a clockwise direction to compress packing against valve stem or counterclockwise to loosen packing.
  - (3) Position handle stop insert (if supplied) around base of valve stem. Install handle onto valve stem and secure with setscrew.
  - (4) Apply pressure to valve and test for leaks using NID solution prepared in accordance with paragraph 4.7.3.2. If necessary, repeat entire procedure until valve is operating properly and a leak-tight seal is achieved at valve stem and ports.

## **6.4 GENERAL REPAIR INFORMATION**

The scope of repairs covered in this chapter includes procedures for removal and replacement of parts repairable at the organizational level. Cleaning and inspection procedures are included if required for the procedure described. Operator/organizational maintenance repair limits are prescribed in the interest of diving safety and optimum service life of the equipment. Components beyond these limits should be sent to a depot facility for repair or replacement.

### **6.4.1 MAINTENANCE PARTS.**

#### **WARNING**

**If in doubt about the serviceability of a part, repair or replace it immediately. Use only approved replacement parts. Failure of a component during a dive may result in diver injury or death.**

Illustrated parts lists for LWDS MK 3 Mod 0 components are provided in Chapter 7. Only approved replacement parts shall be used to repair LWDS equipment.

## SS500-HK-MMO-010

**6.4.2 RELATED MAINTENANCE.** Related corrective maintenance actions include inspection, cleaning, and replacement of parts. Chapter 4 contains a definition of cleanliness as it pertains to a certified system and provides procedures for precleaning, leak detection, and final cleaning; applying Teflon® tape and lubricants; and inspecting, cleaning, removing, and installing O-rings and packings. The procedures outlined in Chapter 4 should be reviewed before attempting the corrective maintenance procedures in this chapter.

Because the LWDS MK 3 Mod 0 is a certified system, providing protection to clean components (i.e., capping or plugging open ports and bagging exposed areas or components) is vital to the maintenance process. Every effort has been made to identify when protection of a part is necessary, but it is the ultimate responsibility of the maintenance technician to maintain cleanliness whether or not the protective action is called out. If in doubt, cap it, plug it, or bag it.

## 6.5 TOOLS AND SUPPORT EQUIPMENT

**6.5.1 TOOLS.** Table 6-2 lists the tools that may be required to perform corrective maintenance on the LWDS. Since the list is all-inclusive, be sure to check the individual maintenance procedure for the required tools.

**Table 6-2. List of Recommended Tools**

Item	Tool Name	Description
1	Crowfoot attachment, socket wrench	Open end, 3/8-inch female drive for use with male socket wrench, assorted sizes
2	Extension bar, solid, socket wrench	1/4 and 3/8 drives, length as required
3	Gauge, thickness (feeler)	U.S. or metric
4	Hammer, hand-held	As required
5	Handle, hinged	1/4 and 3/8 drives, length as required
6	Handle, ratchet, reversible	1/4 and 3/8 drives, length as required
7	Handle, speeder	3/8 drive, 16 inch
8	Joint, universal	3/8 drive
9	Key set, socket head	Assorted sizes
10	Pliers, external snap ring	As required
11	Pliers, slip joint	As required
12	Screwdriver set, flat tip	Assorted sizes
13	Screwdriver set, Phillips head	Assorted sizes
14	Screwdriver, torque	Capable of torquing screws to 6 in-lb (Configuration 1 only)
15	Socket set	1/4 and 3/8 drive, assorted sizes, U.S. and metric
16	Socket, universal joint	3/8 drive, assorted sizes

## SS500-HK-MMO-010

**Table 6-2. List of Recommended Tools—Continued**

Item	Tool Name	Description
17	Wrench, adjustable	As required
18	Wrench set, Allen head	Assorted sizes
19	Wrench set, combination	U.S. and metric, assorted sizes
20	Wrench, strap	As required
21	Wrench, torque	See Table 6-4 for required torque ranges

**6.5.2 SPECIAL TOOLS.** Table 6-3 lists the special tools required to perform corrective maintenance on the LWDS.

**Table 6-3. Special Tools**

Description	Part Number / Manufacturer	Use
Adapter, scuba charging*	Reference Dwg 53711-6314452	Charging scuba bottles
Tachometer, hand-held*	PN HT50 01, CAGE Code 04544 Also reference Dwg 53711-6314451	Adjusting diesel engine speed
Tool, O-ring removal	PN 887-200, Parker-Hannifin	Removing/installing O-rings
Tool, packing adjustment*	PN MS-WK-43, CAGE Code 12623 Also reference Dwg 53711-6314453	Adjusting valve packing for ALP-V401 and ALP-V405

\* Provided with system (see Table 1-2)

**6.5.3 SUPPORT EQUIPMENT.** No support equipment is required.

## **6.6 TORQUE VALUES**

The LWDS has various fasteners threaded into materials of different strengths. The fasteners have specific torque values, depending on their application. Since some torque values are low, careful use of a torque wrench or torque-limiting screwdriver is required to avoid damage to components. Fasteners should be clean and undamaged prior to use. Table 6-4 provides a list of fasteners and torque values.

## **6.7 CONSUMABLE SUPPLIES**

Table 6-5 lists the consumable supplies needed to perform repair procedures in this chapter. The table provides a description of the product or material and its use. Consumable repair parts (such as O-rings) are listed in the maintenance repair instructions for each assembly.



## SS500-HK-MMO-010

Table 6-4. Torque Values

Fastening Application	Fastener(s)	Size and Pitch	Hex Bit/ Socket Size	Torque Value
<b>DIESEL ENGINE</b>				
Decompressor lever	Adjusting screw	---	---	6 in-lb
Fuel pump	Bolt	---	---	78 in-lb
Injector clamp	Capscrew	M8 x 1.25mm	8mm	186 in-lb
Injector leak-off	Swivel union plug	M6 x 1.0mm	6mm	36 in-lb
Valve to rocker clearance	Locknut	---	---	78 in-lb
<b>HP AIR SUPPLY, CONTROL CONSOLE ASSEMBLY, AND VOLUME TANK ASSEMBLY</b>				
Flask shutoff valve	Valve	---	---	75 ft-lb
Flask valve safety assembly	Rupture disk	---	---	45 ft-lb
HP regulator, Tescom	Seat retainer	---	---	100 in-lb
	Vent seat retainer	---	---	50-60 in-lb
	Bonnet	---	---	50 ft-lb
	Setscrew	---	---	20-25 in-lb
Pipe and tubing connector*	37° flare and SAE straight thread	-04	---	132-144 in-lb (11-12 ft-lb)
		-06	---	216-240 in-lb (18-20 ft-lb)
		-08	---	432-468 in-lb (36-39 ft-lb)
		-10	---	624-672 in-lb (52-56 ft-lb)
	O-ring seal	-04	---	3/8 to 1/2 turn after O-ring engagement
		-08	---	
-10		---		
<b>INTERCONNECTING HOSE ASSEMBLIES</b>				
HP Hose Assembly and End Fittings	CGA 346	---	---	snug**

\* For tapered pipe, use Teflon® tape and approved lubricant; tighten until no leakage is observed.

\*\* Tighten CGA until no leakage is observed at 3,000 pounds per square inch gauge (psig).

## SS500-HK-MMO-010

**Table 6-5. Consumable Supplies**

<b>Description</b>	<b>Use</b>
Adhesive, silicone, MIL-A-46106	Gasket adhesive
Bags, plastic, assorted sizes	Component protection; storage or shipping containers
Brush, soft bristle	Cleaning components
Compound, silicone, MIL-S-8660	Lubrication of O-rings, O-ring grooves, and components
Enamel, polyurethane	Flask repair
Gel Coat®, commercial (high grade) or two-part, non water-soluble epoxy	Flask repair
Rags, lint-free, clean	Cleaning and drying components
Sandpaper, 120 and fine grit	Flask repair
Sealant, Wellseal®	Gasket sealant
Solution, cleaning, nonionic detergent (NID) general purpose, MIL-D-16791, Type I	Cleaning components
Solution, leak check, NID (see above); (LEAK-TEK or SNOOP may also be used)	Checking for high and low pressure leaks
Solvent, Methyl Ethyl Ketone (MEK)	Flask repair
Tape, Teflon®, 0.25-inch wide, MIL-T-27730, size 1	Sealing pipe threads
Tape, white, No. 827, 1-inch wide	Sealing polyethylene bags and binding hoses
Tape, white, No. 827, 2-inch wide	Binding hoses
Water, fresh, warm	Cleaning components

**6.8 CORRECTIVE MAINTENANCE PROCEDURES****WARNINGS**

**Accomplish procedures in a clean environment. Contamination of the breathing air system may result in diver injury or death.**

**If in doubt about the serviceability of a part, repair or replace it immediately. Use only approved replacement parts. Failure of a component during a dive may result in diver injury or death.**

This section contains the procedures and information required to perform corrective maintenance on the LWDS. The maintenance reference chart in Table 6-6 provides an overview of the

## SS500-HK-MMO-010

maintenance information covered in this section, along with page number references to the corresponding parts lists in Chapter 7. The corrective maintenance instructions and data are arranged by major component in the order shown below (the snorkel assembly is not included as there is no corrective maintenance authorized for this assembly).

- Para. 6.8.1 — Diesel Engine . . . . . Page 6-16
- Para. 6.8.2 — Air Compressor . . . . . Page 6-26
- Para. 6.8.3 — HP Air Supply and Roof Rack Assembly . . . . . Page 6-38
- Para. 6.8.4 — Volume Tank Assembly . . . . . Page 6-57
- Para. 6.8.5 — Control Console Assembly . . . . . Page 6-75

**Table 6-6. Maintenance Reference Chart**

Nomenclature	Valve	Gauge	Type	Used On	Page References	
Belt, Drive				Air Compressor	6-26	7-6
Covers, Cylinder Head				Diesel Engine	6-16	7-3
Filter, Air				Air Compressor		7-7
Filter, Air, HP Supply				Volume Tank *		7-11
Filter Element				Volume Tank		7-11
Filter Element, Air				Diesel Engine		7-4
Filter Element, Snorkel				Snorkel Assembly		7-7
Filter, Fuel				Diesel Engine		7-4
Flasks, HP Air / Composite				HP Air Supply	6-38	7-32
Gauge, Diver Depth		G318	ALP	Control Console	6-88	7-12
		G319	ALP	Control Console	6-88	7-12
		G320	ALP	Control Console	6-88	7-12
Gauge, Pressure, HP		G211	AHP	Volume Tank *	6-72	7-12
		G316	AHP	Control Console *	6-88	7-12
		G508	AHP	HP Air Supply	6-47	7-12
		G602	AHP	Roof Rack Assy	6-47	7-12
Gauge, Pressure, LP		G212	ALP	Volume Tank	6-73	7-13
		G315	ALP	Control Console	6-87	7-13
		G317	ALP	Control Console	6-87	7-13
		G406	ALP	Air Compressor	6-36	7-13
Injector, Fuel				Diesel Engine	6-21	7-5
Muffler, Exhaust				Diesel Engine	6-23	7-6
Nipple, Hose				HP Hose Assy	6-46	7-10

\* Found in both Mod 0 and Mod 1 configurations

## SS500-HK-MMO-010

Table 6-6. Maintenance Reference Chart—Continued

Nomenclature	Valve	Gauge	Type	Used On	Page References	
O-rings, Inspection Port Plug				Volume Tank		7-32
Panel, Control Console				Control Console	6-75	
Pump, Fuel				Diesel Engine	6-19	7-5
Separator, Moisture				Air Compressor		7-8
Softseat				HP Hose Assy	6-46	7-10
Valve, Ball	V210		ALP	Volume Tank	6-71	7-14
	V302		ALP	Control Console	6-77	7-15
	V304		ALP	Control Console	6-80	7-14
	V305		ALP	Control Console	6-80	7-14
	V306		ALP	Control Console	6-80	7-14
	V401		ALP	Air Compressor	6-29	7-16
	V405		ALP	Air Compressor	6-29	7-16
Valve, Check	V206		ALP	Volume Tank	6-69	7-17
	V303		ALP	Control Console	6-78	7-17
Valve, Flask Shutoff	V505		AHP	HP Air Supply	6-46	7-18
	V506		AHP	HP Air Supply	6-46	7-18
	V507		AHP	HP Air Supply	6-46	7-18
Valve, Gauge Isolation, HP	V202		AHP	Volume Tank	6-64	7-19
	V309		AHP	Control Console	6-87	7-19
Valve, Gauge Isolation, LP	V204		ALP	Volume Tank	6-67	7-20
	V301		ALP	Control Console	6-76	7-20
	V310		ALP	Control Console	6-76	7-20
	V312		ALP	Control Console	6-76	7-20
	V313		ALP	Control Console	6-76	7-20
	V314		ALP	Control Console	6-76	7-20
Valve, Isolation, HP <i>[NOTE: Double page number references refer to Circle Seal and CPV in Chapter 6 and to CPV and Circle Seal in Chapter 7.]</i>	V501		AHP	HP Air Supply	6-42/44	7-22/24
	V502		AHP	HP Air Supply	6-42/44	7-22/24
	V503		AHP	HP Air Supply	6-42/44	7-22/24
	V504		AHP	HP Air Supply	6-42/44	7-22/24
	V601		AHP	Roof Rack Assy	6-50/51	7-22/24
	V604		AHP	Roof Rack Assy	6-54	7-20
Valve, Pilot	V403		ALP	Air Compressor	6-31	7-24

## SS500-HK-MMO-010

**Table 6-6. Maintenance Reference Chart—Continued**

Nomenclature	Valve	Gauge	Type	Used On	Page References	
Valve, Plug	V205		ALP	Volume Tank	6-68	7-25
	V208		ALP	Volume Tank	6-68	7-25
	V209		ALP	Volume Tank	6-68	7-25
	V402		ALP	Air Compressor	6-31	7-25
Valve, Regulator, HP <i>[NOTE: Double page number references refer to Circle Seal and Tescom.]</i>	V201		AHP	Volume Tank	6-57/61	7-27/28
	V307		AHP	Control Console	6-80/84	7-27/28
Valve, Relief, HP	V603		AHP	Roof Rack Assy	6-52	7-31
Valve, Relief, LP				Air Compressor	6-27	7-9
	V207		ALP	Volume Tank	6-70	7-26
	V211		ALP	Mod 1 Vol Tank	6-70	7-26
	V308		ALP	Control Console	6-86	7-26
	V315		ALP	Mod 1 Ctrl Console	6-86	7-26
	V404		ALP	Air Compressor	6-34	7-30
Valve, Unloader				Air Compressor	6-27	7-9
Valve, Vent				Air Compressor	6-28	7-10

**6.8.1 DIESEL ENGINE.** Corrective maintenance for the diesel engine consists of repair to the following components:

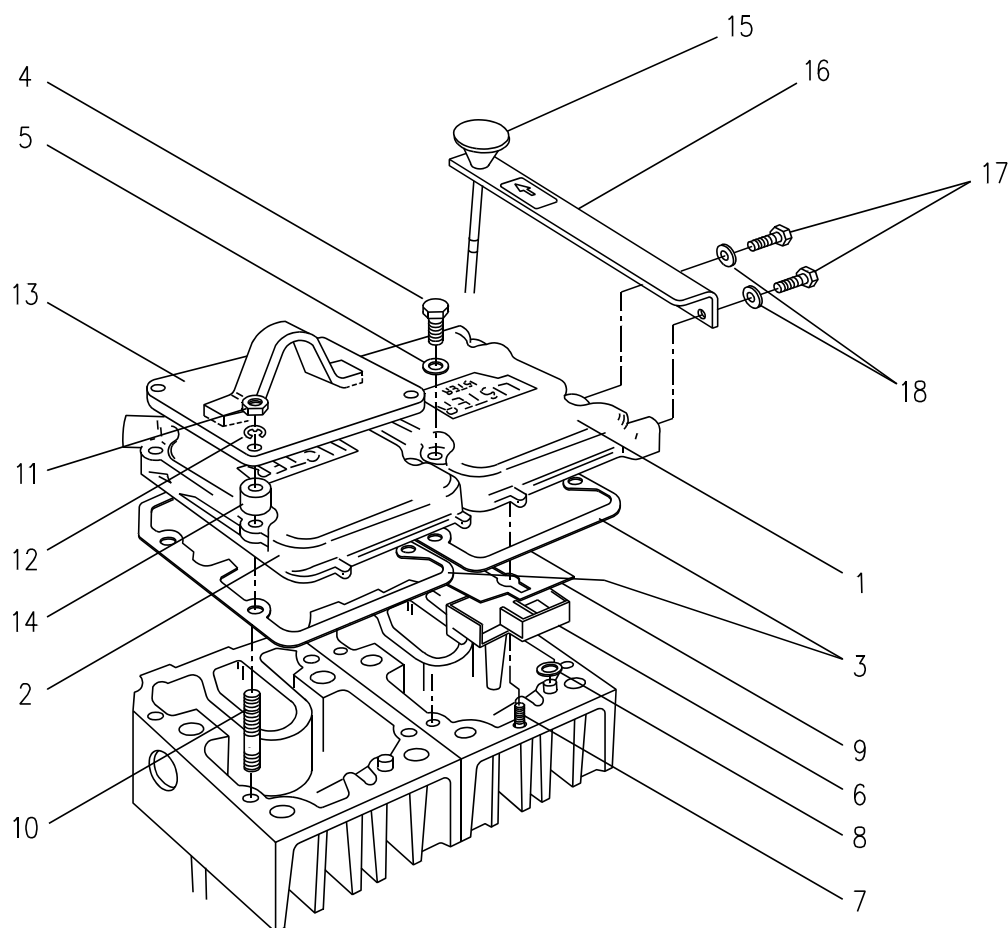
- Para. 6.8.1.1 — Cylinder Head Covers . . . . . Page 6-16
- Para. 6.8.1.2 — Fuel Pumps . . . . . Page 6-19
- Para. 6.8.1.3 — Fuel Injectors . . . . . Page 6-21
- Para. 6.8.1.4 — Exhaust Muffler . . . . . Page 6-23

**6.8.1.1 Cylinder Head Covers.** (Unless otherwise directed, refer to Figure 6-3 for parts location and to Figure 7-1 for replacement parts. Except for items 3 and 15-18, callouts correspond to those found on pages 66-67 in the Lister Petter Parts List.) Removal of the light alloy cylinder head covers (1, 2), which are bolted to the top of the cylinder head assemblies, provides access to the breather box (6), decompressors, fuel injectors, and valves. The lifting eye (13), located on top of the flywheel end cylinder head cover (2), is standard equipment. Items 15-18 are nonstandard components that must be obtained from Coastal Systems Station, Code E53.

a. Remove:

- (1) Remove two mounting bolts (17), two washers (18), and stop plate (16) from gear end cylinder head cover (1). Disconnect cable and return line quick-disconnect.

## SS500-HK-MMO-010



1	Cylinder head cover, gear end . . . . .	601-30491	10	Stud (4) . . . . .	272-00302
2	Cylinder head cover, flywheel end . . . . .	602-30490	11	Nut (4) . . . . .	272-00002
3	Gasket, cylinder head (2) . . . . .	601-30511	12	Spring washer (4) . . . . .	272-00070
4	Capscrew (4) . . . . .	272-00117	13	Lifting eye . . . . .	602-38590
5	Washer, copper (4) . . . . .	291-26090	14	Spacer (4) . . . . .	351-22010
6	Breather box (2) . . . . .	601-32420	15	Stop/run cable . . . . .	See Note 2
7	Screw (2) . . . . .	272-00187	16	Stop plate . . . . .	See Note 2
8	Felt washer (2) . . . . .	601-35440	17	Mounting bolt (2) . . . . .	See Note 2
9	Gasket, breather box (2) . . . . .	601-36921	18	Washer (2) . . . . .	See Note 2

Note 1: Items 1-14 may be ordered from CAGE code 97947 (see Table 7-2 for contact information)

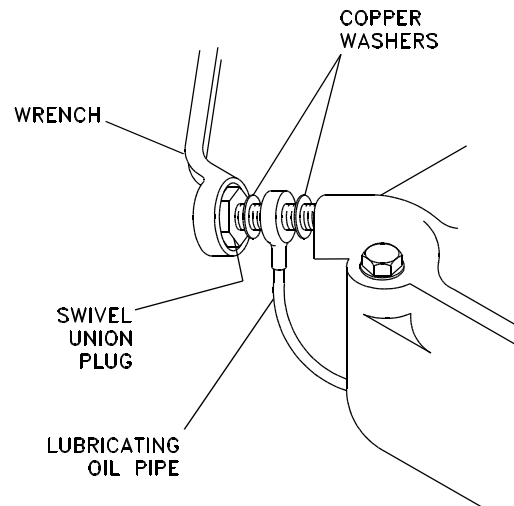
Note 2: Part numbers not available (order from Coastal Systems Station, Code E53—see page 5-1)

**Figure 6-3. Cylinder Head Covers**

- (2) Using 10 mm open-end wrench, remove the four sets of nuts (11) and spring washers (12) from flywheel end cylinder head cover (2), being careful not to lose washers. Studs (10) may come out with nuts, especially if nuts are painted over. Remove lifting eye (13) and four spacers (14), being careful not to lose spacers.

## SS500-HK-MMO-010

- (3) Using a wrench as shown in Figure 6-4, remove swivel union plug and lubricating oil pipe from each cylinder head cover. Remove and discard copper washers.



**Figure 6-4. Removing Swivel Union Plug and Lubricating Oil Pipe**

- (4) Remove four capscrews (Figure 6-3, 4) and four copper washers (5) that secure gear end cylinder head cover (1) to cylinder head assembly.
- (5) Remove gear end cylinder head cover (1), taking care not to damage the fuel leak-off pipe (Figure 6-6, 1) or lose felt washer (Figure 6-3, 8) fitted over cylinder head breather tube.
- (6) With lifting eye (13) removed from flywheel end cylinder head cover (2), carefully lift cover from studs (10) to avoid losing felt washer (8) fitted over cylinder head breather tube.
- (7) Remove and discard cylinder head gasket (3) from each cylinder head assembly.
- b. Replace:
- (1) Ensure two breather boxes (6) and two breather box gaskets (9) are in position and that felt washer (8) is fitted around each cylinder head breather tube.
- (2) Apply silicone adhesive (MIL-A-46106) to top (cover side) of new cylinder head gaskets (3), and install gaskets on cylinder head assemblies.
- (3) Position cylinder head covers (1, 2) over cylinder head gaskets (3), ensuring the decompressor lever (not shown) is located between the two stops and the fuel leak-off pipe (Figure 6-6, 1) is located snugly in recess provided.
- (4) Reinstall four capscrews (Figure 6-3, 4) and four copper washers (5) on gear end cylinder head cover (1).

## SS500-HK-MMO-010

- (5) With the four spacers (14) in place on flywheel end cylinder head cover (2), reinstall lifting eye (13) on cylinder head cover, and reinstall any studs (10) that may have been removed earlier. Secure lifting eye to cylinder head cover with the four sets of spring washers (12) and nuts (11). Tighten with 10 mm open-end wrench.
- (6) Reinstall fuel leak-off pipe (Figure 6-6, 1).
- (7) (Refer to Figure 6-4) Reconnect lubricating oil pipes to cylinder head covers by reinstalling swivel union plugs (PN 601-30945) and new copper washers (PN 291-26090). Torque swivel union plugs to 36 in-lb.
- (8) Using two mounting bolts (Figure 6-3, 17) and two washers (18), reinstall stop plate (16) to gear end cylinder head cover (1). Reconnect cable and return line quick-disconnect.

**6.8.1.2 Fuel Pumps.** The LV2 diesel engine contains two fuel pumps that can be removed and replaced using the following procedure. The procedure covers the removal and replacement of one pump; if both pumps are being replaced, modify the procedure accordingly. Refer to Figure 6-5 for parts location and to Figure 7-4 for replacement parts. Part numbers for parts not mentioned here may be found in the Lister Petter Parts List, pages 70-71.

a. Remove:

- (1) Disconnect fuel feed line (1) from inlet connection (2). Remove inlet connection and copper washer (3) from fuel pump (4). Discard washer.
- (2) Remove self-venting fuel system (5) from both fuel pumps (4).

**NOTE**

To prevent turning when loosening pump-to-injector fuel line nut, hold pump delivery valve holder with wrench.

- (3) Remove pump-to-injector fuel line (Figure 6-6, 2) from pump delivery valve (Figure 6-5, 6).
- (4) Remove fuel pump inspection door from crankcase. (Fuel pump inspection doors are shown as items 14 and 15 on page 32 of Lister Petter Parts List.)

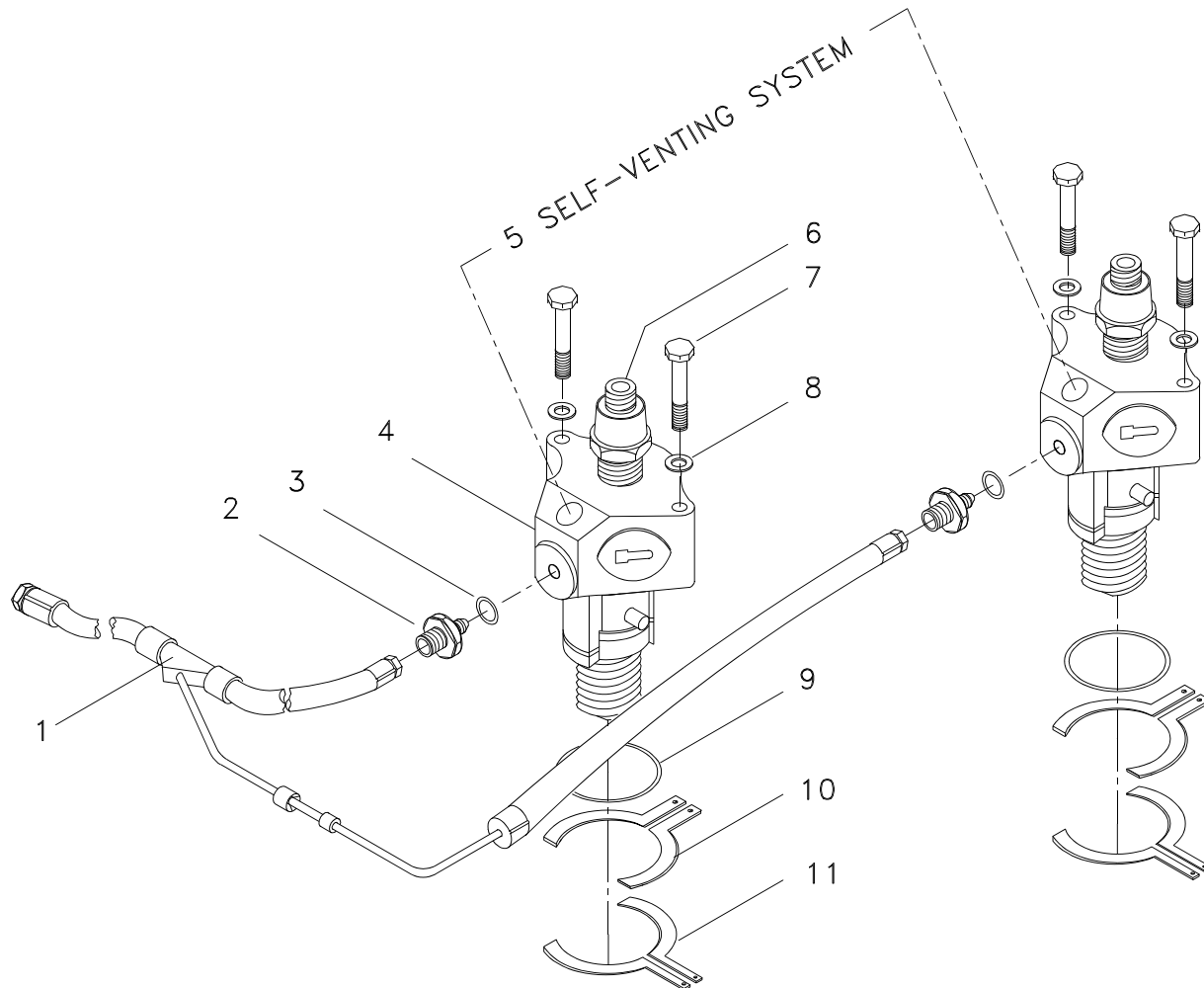
**NOTE**

Refer to pages 60-61 of the Lister Petter Parts List to locate the parts called out in the following step.

- (5) Disconnect speeder spring (6) from speed control lever pin (8). Disconnect governor link assembly (1) and fuel pump link assembly (2) from fuel pump. Set operating lever (19) to central position.



SS500-HK-MMO-010



1	Fuel feed line	602-38031	9	O-ring (2)	601-20691
2	Inlet connection (2)	601-40900	10	Shims (as required)	
3	Washer, copper (2)	616-01608		0.127mm (0.005")	601-21870
4	Fuel pump (2)	601-40650		0.254mm (0.010")	601-21871
5	Self-venting fuel system	Code FG	11	Shims (as required)	
6	Delivery valve (2)	660-14270		0.508mm (0.020")	601-21880
7	Bolt (4)	272-00165		0.762mm (0.030")	601-21881
8	Spring washer (4)	272-00070	NS	Fuel pump element (2)	660-14260

Note: Parts may be ordered from CAGE code 97947 (see Table 7-2 for contact information).

**Figure 6-5. Fuel Pumps**

## SS500-HK-MMO-010

- (6) Remove the two bolts (Figure 6-5, 7) and two spring washers (8), and lift out fuel pump (4). Ensure adjusting shims (10, 11) are not lost below fuel pump body. Cut and discard O-ring (9).

## b. Replace:

- (1) Using approved lubricant, lubricate new O-ring (9). Position the required number of adjusting shims (10, 11) and O-ring (9) on engine block where new fuel pump (4) will be installed. Position fuel pump in engine block, and secure with the two bolts (7) and two spring washers (8). Torque each bolt to 78 in-lb.

**NOTE**

Refer to pages 60-61 of the Lister Petter Parts List to locate the parts called out in the following step.

- (2) Connect governor link assembly (1) and fuel pump link assembly (2) to fuel pump. Connect speeder spring (6) to speed control lever pin (8).
- (3) Set fuel pump and governor distances in accordance with paragraph 6.3.5 of this manual.
- (4) Apply Wellseal® to face of fuel pump inspection door gasket (item 16 on page 32 of Lister Petter Parts List). Install gasket and door (item 14 or 15 on page 32 of Lister Petter Parts List).

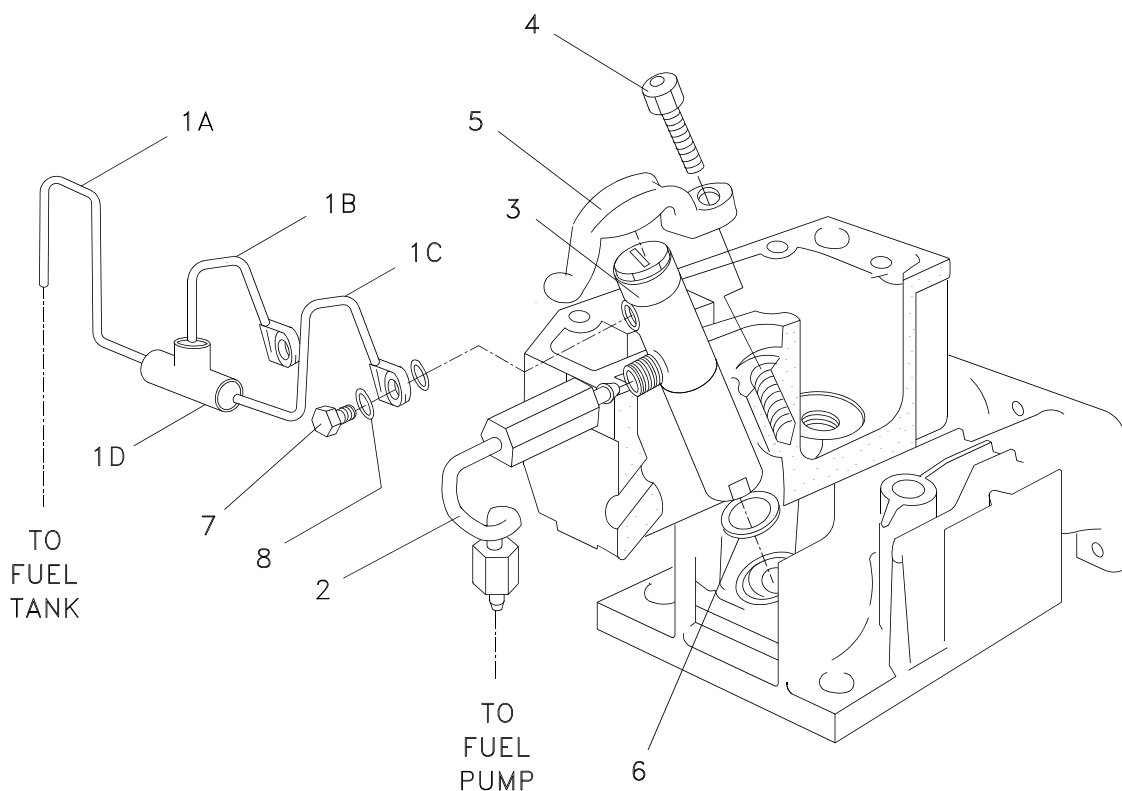
**NOTE**

To prevent turning when tightening pump-to-injector fuel line nut, hold pump delivery valve holder with wrench.

- (5) Install inlet connection (Figure 6-5, 2) with new copper washer (3) on fuel pump (4). Connect fuel feed line (1) to inlet connection, and attach pump-to-injector fuel line (Figure 6-6, 2) to pump delivery valve (Figure 6-5, 6).
- (6) Prime fuel system in accordance with the procedure on page 9 of the Lister Petter Operators Handbook.
- (7) Check fuel pump timing in accordance with paragraph 6.3.4 of this manual.
- (8) Reinstall self-venting fuel system (5) on both fuel pumps (4).

**6.8.1.3 Fuel Injectors.** The LV2 diesel engine contains two fuel injectors that can be removed and replaced using the following procedure. The procedure covers the removal and replacement of one fuel injector; if both fuel injectors are being replaced, modify the procedure accordingly. Refer to Figure 6-6 for parts location and to Figure 7-5 for replacement parts. Part numbers for parts not mentioned here may be found in the Lister Petter Parts List.

## SS500-HK-MMO-010



1	Leak-off piping (1 each)	3	Fuel injector (2) . . . . .	601-36120
1A	Tee piece to fuel tank . . . . .	4	Capscrew (2) . . . . .	272-00257
1B	Tee piece to gear end injector . . . . .	5	Clamp (2) . . . . .	601-36130
1C	Tee piece to flywheel end injector . . . . .	6	Fuel injector washer (2) . . . . .	601-39911
1D	Tee piece . . . . .	7	Swivel union plug (2) . . . . .	601-36100
2	Pump-to-injector fuel line (2) . . . . .	8	Washer, copper (4) . . . . .	291-26090

Note 1: Parts may be ordered from CAGE code 97947 (see Table 7-2 for contact information).

Note 2: Flywheel end injector shown. Both injectors include nozzle (PN 601-37020).

### Figure 6-6. Fuel Injectors

a. Remove:

- (1) Remove cylinder head covers in accordance with paragraph 6.8.1.1.
- (2) Remove leak-off pipe (1A) from fuel tank (not shown).
- (3) Remove pump-to-injector fuel line (2) from fuel pump (not shown).
- (4) Remove capscrew (4) and clamp (5) from each cylinder head.
- (5) Remove fuel injector (3) (with leak-off pipe (1C) and pump-to-injector fuel line (2) still attached) and fuel injector washer (6) from cylinder head.

## SS500-HK-MMO-010

(6) Remove swivel union plug (7) and copper washers (8) from fuel injector (3); remove leak-off pipe (1B). Remove pump-to-injector fuel line (2) from fuel injector.

b. Replace:

(1) Attach pump-to-injector fuel line (2) to new fuel injector (3). Do not tighten.

(2) Attach leak-off pipe (1B) to fuel injector (3) with swivel union plug (7). Ensure copper washers (8) are positioned on swivel union plug on each side of leak-off pipe. Do not tighten.

(3) Install fuel injector washer (6) and new fuel injector (3) in cylinder head.

(4) Reinstall clamp (5) and capscrew (4) to secure fuel injector (3) in cylinder head. Torque capscrew (4) to 186 in-lb.

(5) Attach pump-to-injector fuel line (2) to fuel pump (Figure 6-5, 4) and tighten. Also tighten pump-to-injector fuel line to fuel injector (Figure 6-6, 3).

(6) Tighten leak-off pipe (1B) to fuel injector (3) 1/2 turn after union contacts washers (8).

(7) Attach leak-off pipe (1A) to fuel tank (not shown).

(8) Run diesel engine and check for leaks.

**6.8.1.4 Exhaust Muffler.** Remove and replace the diesel engine exhaust muffler in accordance with the following procedure. Refer to Figure 6-7, Sheet 1 for location of muffler and to Figure 7-6 for illustration and ordering information.

a. Remove nuts holding muffler to exhaust manifold. Remove muffler.

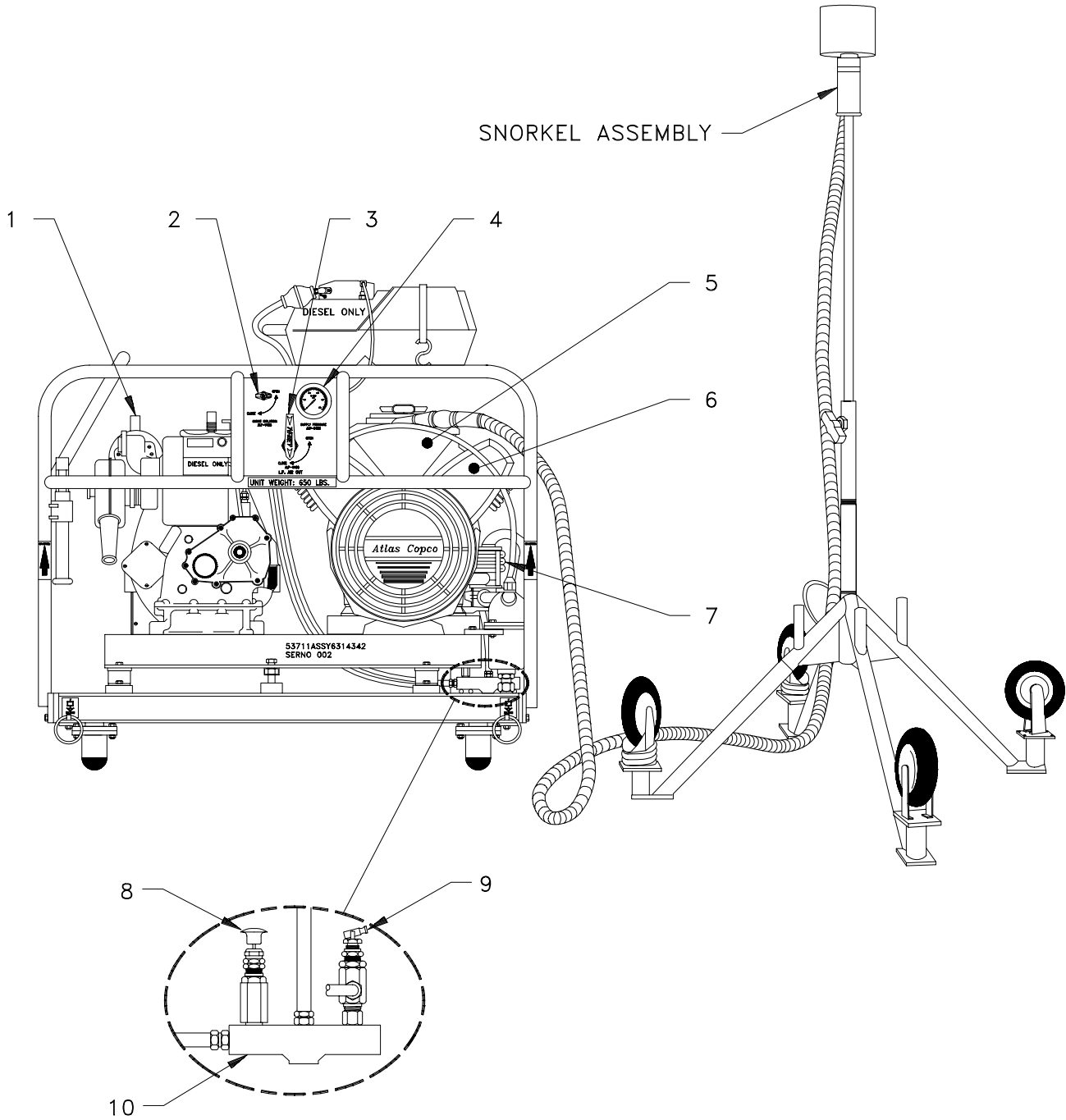
b. Replace with new muffler as follows:

(1) Mount muffler on exhaust manifold.

(2) Reinstall and tighten nuts on exposed threads to secure muffler to manifold.

(3) Ensure exhaust outlet points upward and is unrestricted for operation.

SS500-HK-MMO-010

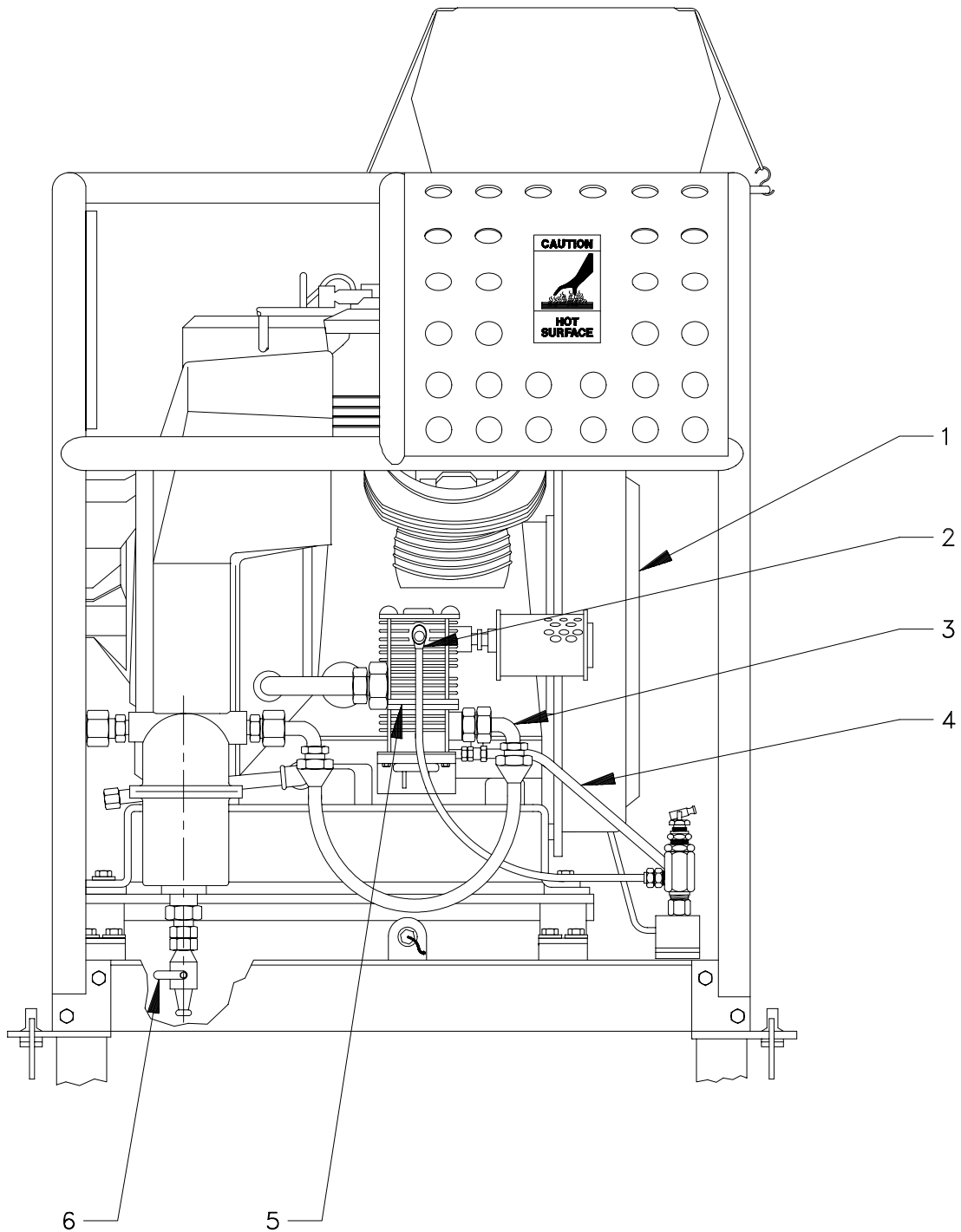


Shows view as seen from front of assembly--  
manifold located at rear of assembly

- |  |                                       |
|--|---------------------------------------|
| 1. Exhaust muffler                             | 6. Relief valve (on pulsation damper) |
| 2. Compressor gauge isolation valve (ALP-V405) | 7. Unloader valve                     |
| 3. Compressor outlet supply valve (ALP-V401)   | 8. Relief valve (ALP-V404)            |
| 4. Compressor pressure gauge (ALP-G406)        | 9. Pilot valve (ALP-V403)             |
| 5. Vent valve (inside silencer)                | 10. Compressor manifold               |

**Figure 6-7. Diesel-Compressor Assembly Parts Location (Sheet 1 of 2)**

### SS500-HK-MMO-010



- |  |  |
|--|--|
| 1. Drive belt (inside belt guard)            | 4. Control line (H-405) to pilot valve       |
| 2. Control line (H-404) from pilot valve     | 5. Unloader valve                            |
| 3. Final air discharge to moisture separator | 6. Moisture separator drain valve (ALP-V402) |

**Figure 6-7. Diesel-Compressor Assembly Parts Location (Sheet 2 of 2)**

## SS500-HK-MMO-010

**6.8.2 AIR COMPRESSOR.** Corrective maintenance for the air compressor consists of removal and replacement of the components listed below. Valve and gauge Joint Identification Drawing (JID) numbers (if assigned) are shown in parentheses and page numbers are shown flush right. Figure 6-7 shows the general location of the parts addressed in this section.

- Para. 6.8.2.1—Drive Belt . . . . . Pg 6-26
- Para. 6.8.2.2—Relief Valve . . . . . Pg 6-27
- Para. 6.8.2.3—Unloader Valve . . . . . Pg 6-27
- Para. 6.8.2.4—Vent Valve . . . . . Pg 6-28
- Para. 6.8.2.5—Ball Valves (ALP-V401, ALP-V405) . . . . . Pg 6-29
- Para. 6.8.2.6—Plug Valve (ALP-V402) . . . . . Pg 6-31
- Para. 6.8.2.7—Pilot Valve (ALP-V403) . . . . . Pg 6-31
- Para. 6.8.2.8—LP Relief Valve (ALP-V404) . . . . . Pg 6-34
- Para. 6.8.2.9—LP Pressure Gauge (ALP-G406) . . . . . Pg 6-36

**6.8.2.1 Drive Belt.** Remove and replace the drive belt that connects the diesel engine to the air compressor in accordance with the following procedure. Refer to Figure 6-7 for location and Figure 7-7 for illustration and replacement parts.

a. Remove:

- (1) Remove screws, nuts, and washers securing plastic belt guard. Remove belt guard and reinforcing straps.
- (2) Loosen bolt on belt guard backing plate securing plate to diesel engine. Loosen bolts securing plate to compressor and frame.
- (3) Loosen the four mounting bolts securing diesel engine to frame.
- (4) Loosen belt tension by adjusting belt tensioning bolts.
- (5) Remove and discard drive belt.

b. Replace:

- (1) Install new drive belt.
- (2) Tighten the two tensioning bolts simultaneously to keep engine and compressor pulleys parallel, until drive belt can be deflected 1/2 to 3/4 inch at center of span.
- (3) Place straight edge along the two pulleys, parallel to drive belt. If straight edge does not lie flush, rotate engine by tightening or loosening one belt tension adjustment bolt (usually bolt closest to drive pulley). Do not overtighten drive belt.

**NOTE**

If pulley is removed from shaft, move pulley in or out on shaft by loosening three attachment bolts. Tap hub in or out on shaft as required.

## SS500-HK-MMO-010

- (4) Tighten the four sets of nuts, bolts, and washers securing diesel engine to sub-assembly.
- (5) Tighten bolt on belt guard backing plate securing plate to engine. Tighten bolts securing plate to compressor and frame.
- (6) Reinstall plastic belt guard and reinforcing straps. Reinstall screws, nuts, and washers securing belt guard.

**6.8.2.2 Relief Valve.** Corrective maintenance of the relief valve that is located on top of the pulsation damper on the compressor is limited to removal and replacement of the valve in accordance with the following procedure. Refer to Figure 6-7 for location and to Figure 7-11 for an illustration and index of replacement parts.

**WARNING**

**Approved reentry control must be used for this procedure.**

- a. Remove:
  - (1) Ensure compressor cylinder heads have been depressurized.
  - (2) Remove the eight bolts from plastic fan shroud; remove fan shroud.
  - (3) Remove relief valve (near inlet of second-stage (right-hand) cylinder head).
- b. Replace:
  - (1) Wrap Teflon® tape around male threads and install valve using new gasket; tighten valve finger-tight and then turn another 1/2 to 3/4 turn using a 9/16-inch open-end wrench.
  - (2) Reinstall plastic fan shroud using the eight bolts.
  - (3) Complete reentry control report and log.

**6.8.2.3 Unloader Valve.** Corrective maintenance for the compressor unloader valve is limited to removal and replacement. Refer to Figure 6-7 for location and to Figure 7-12 for an illustration and index of replacement parts.

**WARNING**

**Approved reentry control must be used for this procedure.**

- a. Remove:
  - (1) Remove exhaust muffler (paragraph 6.8.1.4) and disconnect unloader sensing lines H-403, H-404, and H-405. Remove adapter fittings; bag fittings and open lines.



## SS500-HK-MMO-010

- (2) Disconnect aftercooler and air outlet. Remove adapter fittings and bag open lines.
- (3) Unscrew the two sets of nuts and washers securing unloader valve to compressor crankcase. Remove unloader valve.

## b. Replace:

- (1) Install new unloader valve using nuts and washers; tighten both nuts.

**CAUTION**

Tighten fittings carefully to avoid damage to aluminum unloader assembly.

- (2) Using new Teflon® tape on pipe connections and new sealing ring on aftercooler, install new fittings. Carefully tighten fittings.

**CAUTION**

To prevent damage to compressor, ensure sensing lines are positioned correctly.

- (3) Reconnect sensing lines, install exhaust muffler (paragraph 6.8.1.4), start engine, and engage compressor. Using NID solution prepared in accordance with paragraph 4.7.3.2, check for leaks. Tighten as required.
- (4) Complete reentry control report and log.

**6.8.2.4 Vent Valve.** Corrective maintenance of the compressor vent valve, which is located inside the silencer, is limited to removal and replacement. Refer to Figure 6-7 for location and to Figure 7-13 for illustration and index of replacement parts. Numbers in parentheses within the text refer to the callouts on page 2 of the Atlas Copco Parts List.

**CAUTION**

Do not allow water or debris to enter the oil fill pipe during performance of this procedure.

## a. Remove:

- (1) Unscrew oil cover (44) from cover (43); remove cover from housing (40). Ensure seal (28) remains in cover.
- (2) Remove air filter element (42).
- (3) Remove the four sets of bolts (41), washers (38), and nuts (39) that secure housing (40) to silencer (26). Remove housing.

## SS500-HK-MMO-010

- (4) Remove the four bolts that mount silencer to cylinder heads.
  - (5) Slide silencer (26) upward until vent valve (9) pulls free from seal (29).
  - (6) Unscrew vent valve (9) and discard.
- b. Replace:
- (1) Install new vent valve (9).
  - (2) Inspect seals (28, 29) and replace as necessary.
  - (3) Insert silencer (26) until vent valve (9) seats in seal (29).
  - (4) Reinstall the four bolts that mount silencer (26) to cylinder heads.

**CAUTION**

Do not overtighten bolts. If plastic deforms or gasket extrudes, bolts are too tight and seal must be replaced.

- (5) Using bolts (41), washers (38), and nuts (39), secure housing (40) to silencer (26). Tighten bolts approximately 1/2 turn beyond hand-tight.
- (6) Inspect air filter element (42) and replace if necessary. Install air filter element in housing (40).
- (7) Install cover (43) over air filter element (42) and onto housing (40). Ensure seal (28) is secured in center of cover.
- (8) Screw oil cover (44) on exposed threads and secure cover (43) to housing (40). Tighten oil cover 1 to 1-1/2 turns after resistance is felt.

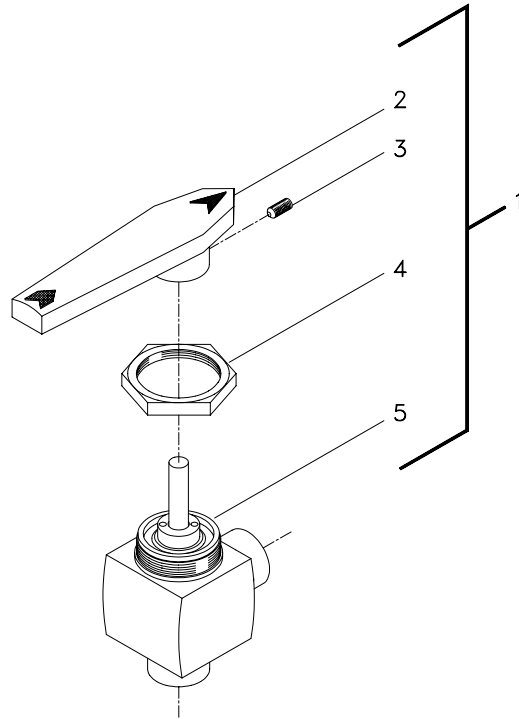
**6.8.2.5 Ball Valves (ALP-V401, ALP-V405).** Remove and replace the compressor ball valves (ALP-V401, ALP-V405) in accordance with the following procedure, which applies only to the two valves referenced here. Although the two valves are not interchangeable (ALP-V401 is 1/2 NPT and ALP-V405 is 1/4 NPT), the design is the same and therefore the same procedure can be used for removal and replacement. Refer to Figure 6-7 for location and to Figure 7-23 for an index of replacement parts. The callouts in this procedure refer to Figure 6-8.

**WARNING**

**Approved reentry control must be used for this procedure.**

- a. Remove:
- (1) Remove setscrew (3) from handle (2). Remove handle from valve stem.

## SS500-HK-MMO-010



**Figure 6-8. Ball Valves  
(ALP-V401, ALP-V405)**

- (2) Remove hoses from adapter fittings.
  - (3) Remove panel nut (4) from valve body (5), and remove valve body (5) from rear of panel.
  - (4) Remove adapter fittings from valve.
- b. Replace:
- (1) Ensure replacement valve has been cleaned in accordance with MIL-STD-1330 or other approved NAVSEA cleaning procedure for life support systems.
  - (2) Remove setscrew (3) from handle (2) on new valve (1). Remove handle and panel nut (4).
  - (3) Place Teflon® tape on adapter threads and install adapters into valve body (5).
  - (4) Position new valve (1) through rear of panel.
  - (5) Install hoses to adapter fittings.
  - (6) Install panel nut (4) onto valve body (5).
  - (7) Install handle (2) onto valve stem and secure with setscrew (3).

## SS500-HK-MMO-010

- (8) Apply pressure and leak test valve using NID solution prepared in accordance with paragraph 4.7.3.2. If leakage is detected, adjust packing in accordance with procedure a in paragraph 6.3.10.
- (9) Complete reentry control report and log.

**6.8.2.6 Plug Valve (ALP-V402).** Corrective maintenance for the compressor moisture separator drain valve (ALP-V402) consists of replacement of the valve or replacement of the O-rings within the valve. No procedure for O-ring replacement has been provided since replacement can be accomplished using an O-ring kit and the exploded view in Figure 7-31. Other plug valves of this type are ALP-V205, -V208, and -V209 in the volume tank assembly (paragraph 6.8.4.4). Refer to Figure 6-7 for valve location and to Figure 7-31 for an illustration and index of parts.

**WARNING**

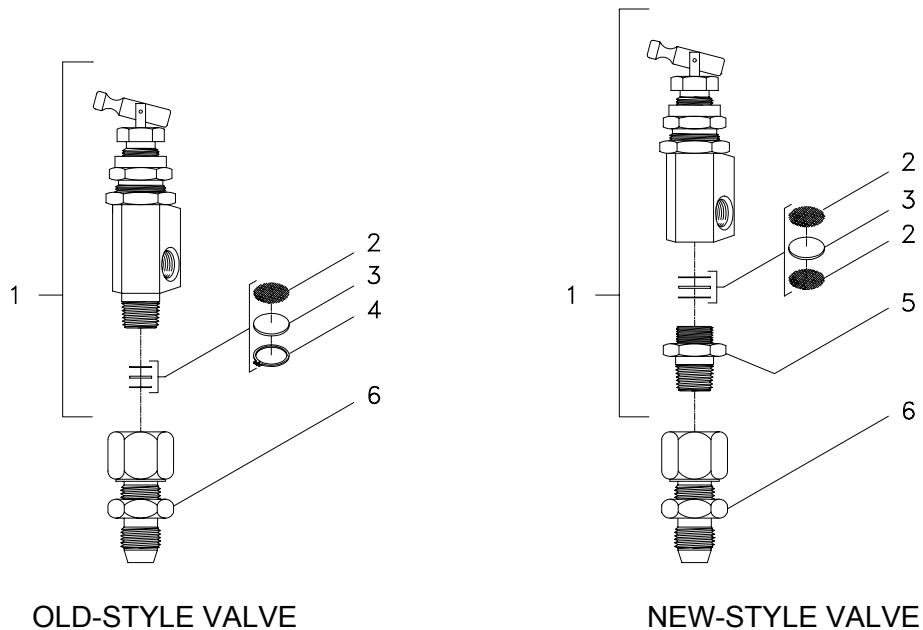
**Approved reentry control must be used for this procedure.**

- a. Remove:
  - (1) Depressurize system.
  - (2) Loosen union nut with wrench, and remove plug valve from adapter.
  - (3) Ensure all Teflon® tape is removed from adapter threads.
- b. Replace:
  - (1) Ensure replacement valve has been cleaned in accordance with MIL-STD-1330 or other approved NAVSEA cleaning procedure for life support systems.
  - (2) Wrap Teflon® tape around inlet threads on adapter end of new plug valve.
  - (3) Insert taped end of new plug valve into adapter, and tighten union nut with wrench.
  - (4) Pressurize system and leak test valve using NID solution prepared in accordance with paragraph 4.7.3.2. Correct leaks as necessary.
  - (5) Complete reentry control report and log.

**6.8.2.7 Pilot Valve (ALP-V403).** Corrective maintenance for the compressor pilot valve (ALP-V403) consists of removal and replacement of the valve, as well as cleaning or replacement of the filter components. Two versions of this valve are authorized for use with the LWDS, each containing a different type of inlet and filter design. The old-style valve, which is shown on the left in Figure 6-9, features a removable filter screen (2), felt (3), and ring (4) installed in the tip of the valve inlet, which is an integral part of the valve body. The new-style valve features a filter composed of felt (3) sandwiched between two screens (2). The filter is located inside the valve body and held in place with a filter nut (5). Corrective maintenance for the filters must therefore be adapted to the style of valve that is installed on the compressor manifold. While the old-style

## SS500-HK-MMO-010

valves are still approved for use, they are no longer available from the manufacturer and will be automatically replaced with the new-style valve when ordering. Refer to Figure 6-7 for valve location and to Figure 7-30 for an index of replacement parts for ALP-V403, which is the only valve of its type in the system. The callouts in the following procedure refer to Figure 6-9, which depicts both an old-style and new-style pilot valve removed from the bulkhead connector (6).



**Figure 6-9. Pilot Valve (ALP-V403)**

**WARNING**

**Approved reentry control must be used for this procedure.**

a. Remove:

- (1) Remove hose adapter from side port in pilot valve (1).
- (2) **For replacement or cleaning of old-style valve or for replacement only of new-style valve:** Remove valve (1) from bulkhead connector (6). If necessary, remove bulkhead connector from manifold first, and then remove bulkhead connector from valve. Remove all traces of Teflon® tape from threads inside bulkhead connector, and from old-style valve inlet if filter components are to be cleaned or replaced.
- (3) **For cleaning of new-style valve filter only:** Remove top portion of pilot valve (1) from filter nut (5) as shown in Figure 6-9. If necessary, remove bulkhead connector (6) from manifold first, and then remove filter nut (5) from valve body.

## SS500-HK-MMO-010

- (4) If bulkhead connector (6) was removed from manifold in step (2) or (3), remove, cut, and discard bulkhead connector O-ring.
  - (5) If cleaning or replacement of filter components is required, continue with step b; otherwise, proceed to step c for installation of new valve.
- b. If the pilot valve has not been operating within specified limits, the filter components are probably dirty and should be cleaned as follows to improve performance:
- (1) Using a tool with a pointed tip, carefully remove the filter components from the valve in accordance with one of the following. For old-style valves: Carefully remove ring (4), felt (3), and screen (2) from valve inlet. For new-style valves: Carefully remove the first screen (2), felt (3), and second screen (2) from valve body.
  - (2) Using a clean cloth, wipe off any dirt or contaminants from filter components. If a component is damaged or cannot be sufficiently cleaned, replace the affected component (see Figure 7-30 for index of replacement parts).
  - (3) Reinstall filter components in reverse order of removal. For new-style valves only, also reinstall filter nut (5).
- c. Install cleaned or replacement valve in accordance with the following:
- (1) If pilot valve (1) was separated from bulkhead connector (6): Wrap Teflon® tape around valve inlet threads and install valve in bulkhead connector.
  - (2) If bulkhead connector (6) was removed from manifold: Using approved lubricant, lubricate new O-ring (M83248/2-906). Install O-ring on connector threads and insert bulkhead connector (with valve attached) into manifold. Tighten as required.
  - (3) Connect hose adapter to side port in pilot valve (1).
  - (4) Using the procedure given in paragraph 6.3.9, test pilot valve for proper cycling and adjust as necessary. Do not shut down system until step (5) has been performed. If detailed instructions are required for setting up the diesel-compressor and volume tank assemblies, refer to the applicable steps in Table 2-7 for setup procedures and to Table 2-8 for start-up procedures.
  - (5) With system still under pressure, check pilot valve connections for leaks using NID solution prepared in accordance with paragraph 4.7.3.2. Correct leaks as necessary.
  - (6) Secure equipment. If detailed instructions for shutdown are required, refer to the applicable steps in Part I of Table 2-16.
  - (7) Complete reentry control report and log.

## SS500-HK-MMO-010

**6.8.2.8 LP Relief Valve (ALP-V404).** Corrective maintenance for compressor LP relief valve (ALP-V404) is limited to removal of the old valve and modification and installation of the new valve. ALP-V404 is identical to the HP relief valve for the roof rack assembly (AHP-V603) with the following exceptions:

- **Manual override handle (ALP-V404) versus cap plug (AHP-V603):** AHP-V603, which is strictly an automatic relief valve with no manual controls, is capped off at the top with a cap plug. ALP-V404 is also an automatic relief valve, but unlike AHP-V603, it features a manual override handle that allows the operator to manually relieve upstream pressure without disturbing the relief pressure setting. When replacement of ALP-V404 is required, a couple of options are available. If surplus AHP-V603 valves are on hand, simply order a manual override handle kit and a blue spring kit (see below), and modify one of the valves for use on the compressor in accordance with the procedure in Step b(1). If surplus valves are not available, use the part numbers shown in Figure 7-35 to order the basic valve, a manual override handle kit, and a blue spring kit. Upon receipt, modify the valve with the two kits in accordance with the procedure in Step b(1). The manual override handle kit contains a phenolic handle, 316 SS pull rod, 316 SS spring support, and installation instructions.
- **Blue spring kit (ALP-V404) and white spring kit (AHP-V603):** When ordering the valves in Figures 7-35 and 7-36, the appropriate spring kit must also be ordered as the manufacturer supplies R3A valves without a spring. Each of the spring kits includes a color-coded spring that corresponds to a particular cracking pressure range, a label, a lockwire/lead seal, a spring support disc, and installation instructions. ALP-V404 uses a blue spring with a cracking pressure range of 50-350 psig, while AHP-V603 uses a white spring with a range of 3,000-4,000 psig. To increase the valve's cracking pressure within the available range, compress the spring by turning the adjustment cap in a clockwise direction. A lockwire provided in the kit can be used to maintain the new setting. The spring support discs used in the two kits described here vary in thickness and are not interchangeable.

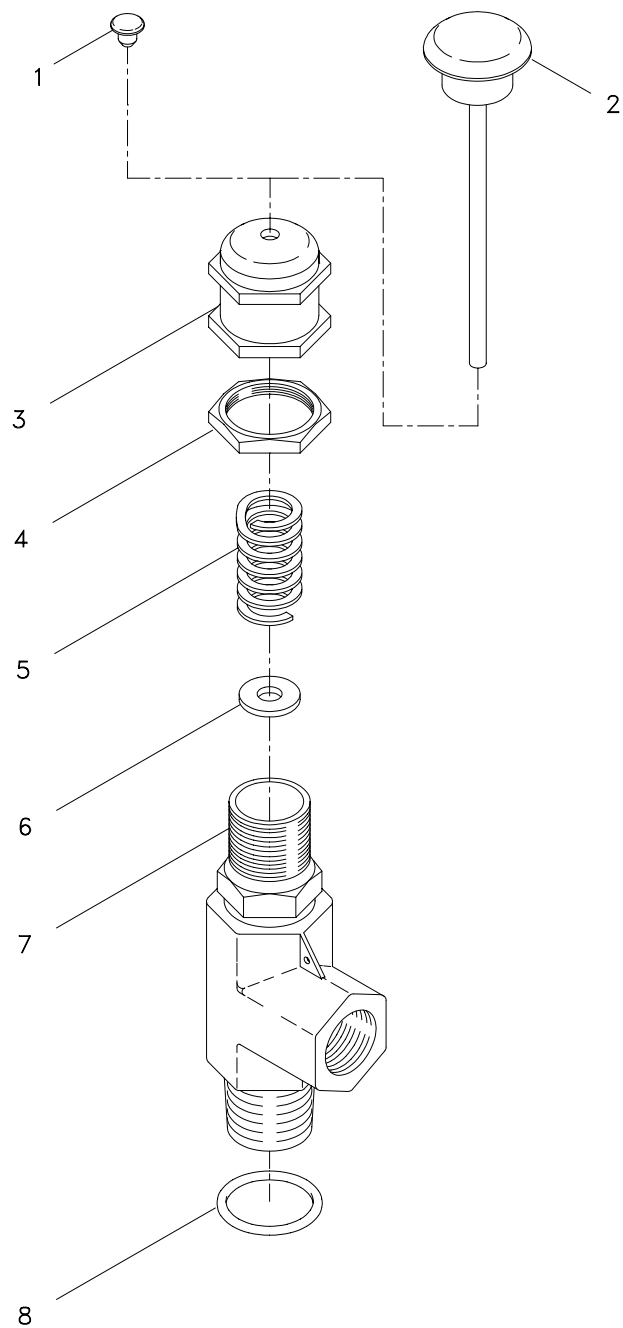
The removal, modification, and replacement procedures for AHP-V603 are presented in paragraph 6.8.3.6, and the procedures for ALP-V404 are provided below. Valve location for ALP-V404 is shown in Figure 6-7, and Figure 7-35 provides an index of replacement parts. The callouts in the following procedure refer to Figure 6-10.

**WARNING**

**Approved reentry control must be used for this procedure.**

- a. Remove old valve:
  - (1) Remove relief valve from compressor manifold. Bag opening in manifold.
  - (2) Remove, cut, and discard O-ring (8).

SS500-HK-MMO-010



**Figure 6-10. LP Relief Valve (ALP-V404)**



## SS500-HK-MMO-010

## b. Prepare new valve for installation as follows:

- (1) Modify valve in accordance with the following: Remove adjustment cap (3) from bonnet (7), and remove cap plug (1) from adjustment cap (3). Install spring support disc (6) and blue spring (5) from spring kit (PN 177-R3A-K1-A) and handle (2) from manual override handle kit (PN SS-R3A-K5) and reassemble valve in accordance with installation instructions included in both kits.
- (2) Clean modified valve in accordance with MIL-STD-1330 or other approved NAVSEA cleaning procedure for life support systems.
- (3) Set valve to relieve at 200 psi by turning adjustment cap (3) clockwise until correct setting is obtained. Lock cap in place with locking nut (4) and secure with lockwire from spring kit.

## c. Install modified valve:

- (1) Using approved lubricant, lubricate new O-ring (8, PN M83248/2-906) and install on threads of new relief valve.
- (2) Remove bagging from compressor manifold, and install new relief valve in manifold.
- (3) Apply pressure and test valve for leaks using NID solution prepared in accordance with paragraph 4.7.3.2. Correct leaks as necessary.
- (4) Complete reentry control report and log.

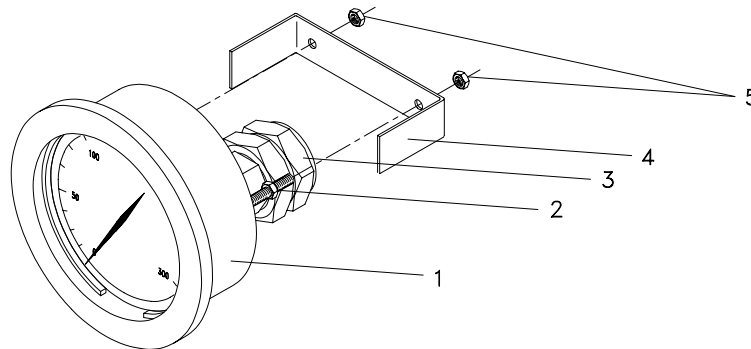
**6.8.2.9 LP Pressure Gauge (ALP-G406).** Corrective maintenance for compressor LP pressure gauge (ALP-G406), which is the only one of its kind in the system, is limited to removal and replacement. The gauge is supplied with a snubber, the gauge side of which has been filled with silicone oil and sealed at assembly. If the snubber is damaged, the entire gauge must be replaced since removal of the snubber is prohibited. If the gauge is being removed for calibration purposes and will be used again at a later date, ensure cleanliness is maintained at all times. Refer to Figure 6-7 for location and to Figure 7-20 for an index of replacement parts. The callouts in the following procedure refer to Figure 6-11.

**WARNINGS**

**Approved reentry control must be used for this procedure.**

**Exercise extreme care when handling pressure gauges. Failure to keep gauges, tools, and parts free of oil, grease, rust, or contaminants may cause damage or inaccurate readings. Failure to observe this warning may result in equipment failure and injury or death to personnel.**

## SS500-HK-MMO-010



**Figure 6-11. LP Pressure Gauge (ALP-G406)**

a. Remove:

- (1) Ensure gauge (1) is not under pressure.
- (2) Remove flex hose elbow fitting from adapter. Bag elbow fitting.
- (3) Remove the two mounting bracket hex nuts (5) and mounting bracket (4) from the two mounting bracket studs (2).
- (4) Remove gauge (1) from panel.
- (5) Remove mounting bracket studs (2) from rear of gauge (1).

**CAUTION**

**Do not remove snubber from this gauge.** Failure to comply will result in damage to the gauge.

- (6) Remove adapter fitting from snubber (3). Remove all traces of Teflon® tape from threads of adapter fitting (and from snubber if valve is to be reused). Bag adapter fitting.
- (7) If gauge is to be calibrated, tag and bag gauge in accordance with approved procedures and send to authorized calibration facility; otherwise, discard valve.

b. Replace:

- (1) Ensure calibration of replacement gauge is current. Also ensure that gauge has been cleaned in accordance with MIL-STD-1330 or other approved NAVSEA cleaning procedure for life support systems.
- (2) Install the two mounting bracket studs (2) on replacement gauge (1).

## SS500-HK-MMO-010

- (3) Using Teflon® tape, wrap tape around threads of snubber end of adapter fitting, and install adapter fitting to snubber (3) on replacement gauge (1).
- (4) Position gauge (1) in panel.

**WARNING**

**Ensure gauge is securely installed. Failure to tighten gauge securely may result in damage to equipment and injury or death to personnel.**

- (5) Install and secure mounting bracket (4) to gauge (1) with the two hex nuts (5).

**CAUTION**

Do not let stem rotate in the gauge. Failure to comply will result in damage to the gauge.

- (6) Position and tighten flex hose elbow fitting to adapter fitting.
- (7) Pressurize gauge. Using NID solution prepared in accordance with paragraph 4.7.3.2, check gauge for leaks and correct as necessary.
- (8) Complete reentry control report and log.

**6.8.3 HP Air Supply and Roof Rack Assembly.** Corrective maintenance for the HP air supply and roof rack assembly consists primarily of removal and replacement of the following components. If repair of a component has been authorized, the repair procedure is included in the maintenance procedures for that component. Valve and gauge JID numbers, if assigned, are shown in parentheses in the index below and the page numbers where the procedures can be found are shown flush right.

- Para. 6.8.3.1—HP Air Flasks . . . . . Pg 6-38
- Para. 6.8.3.2—HP Isolation Valves (AHP-V501, -V502, -V503, -V504) . . . . . Pg 6-42
- Para. 6.8.3.3—Flask Shutoff Valves (AHP-V505, -V506, -V507) . . . . . Pg 6-46
- Para. 6.8.3.4—HP Pressure Gauges (AHP-G508, -G602) . . . . . Pg 6-47
- Para. 6.8.3.5—HP Isolation Valve (AHP-V601) . . . . . Pg 6-49
- Para. 6.8.3.6—HP Relief Valve (AHP-V603) . . . . . Pg 6-52
- Para. 6.8.3.7—HP Isolation Valve (AHP-V604) . . . . . Pg 6-54

**6.8.3.1 HP Air Flasks.** The following procedure presents the steps required to remove, repair, and install the HP air flasks. The removal and installation steps may also be required in other procedures in this section if removal of one or more flasks is necessary to allow access for maintenance purposes. The flasks in each flask rack assembly are identified by the JID numbers assigned to the flask shutoff valves. Although the valves are identical, their position within the flask rack assembly determines the designation. From left to right, the valves are identified as AHP-V505, AHP-V506, and AHP-V507. AHP-V505 and AHP-V507 are connected to HP hose

## SS500-HK-MMO-010

assemblies, whereas AHP-V506 is connected to a cross. Refer to Figure 7-37 for an index of replacement part numbers and to Appendices C, D, and E for detailed inspection and handling procedures for HP air flasks. Unless otherwise noted, the callouts in the procedure below refer to Figure 6-12.

- a. Remove flask(s) to be repaired or replaced from flask rack assembly in accordance with the following procedure:

**CAUTION**

Handle flask racks and flasks carefully to avoid damage to equipment during removal/installation.

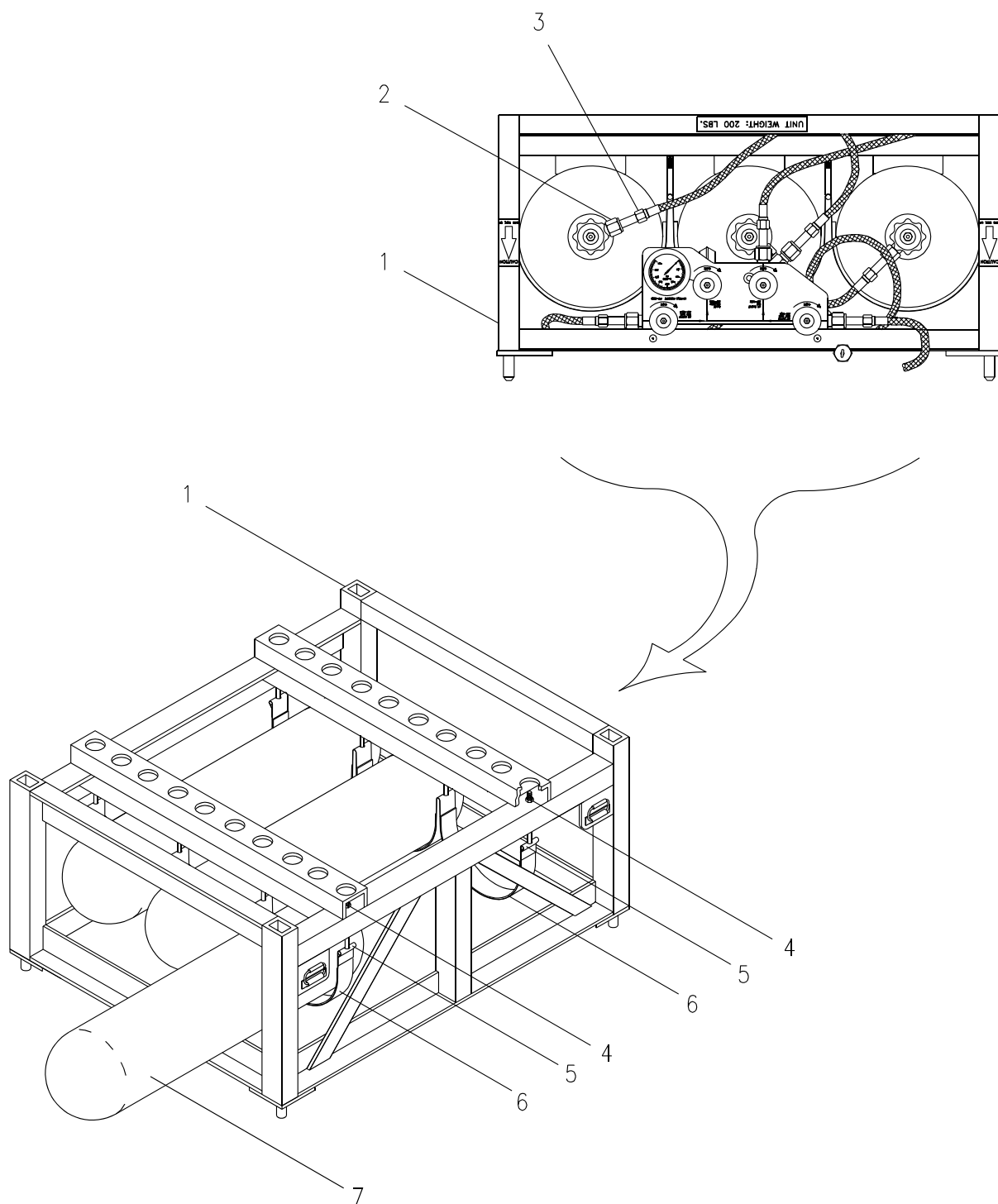
- (1) Invert flask rack assembly (1) to provide access to nuts (4) and T-bolts (5).
- (2) Using scrub brush and NID solution prepared in accordance with paragraph 4.7.3.2, thoroughly clean flask shutoff valve and attached fittings of flask(s) to be removed. Other components of the flask rack assembly may also be cleaned if desired.
- (3) Working only with flask(s) to be repaired or replaced, remove hose or cross fitting, whichever is applicable, from flask shutoff valve by loosening CGA 346 nut (2) while holding 3/4-inch hex nut (3) in place.
- (4) Remove softseat (Figure 6-15, 3) from hose or cross nipple; discard softseat. Bag exposed hose or cross fittings to keep the system free from contaminants.
- (5) Bleed all air from flask(s) to be removed. Bag flask shutoff valve(s).
- (6) Loosen both strap assemblies (Figure 6-12, 6) evenly while holding T-bolts (5) with a pair of pliers and loosening nuts (4) until flask (7) rotates easily.
- (7) Slide flask (7) out through rear of flask rack assembly (1). Use caution to avoid damaging flask.
- (8) Repeat steps (6) and (7) for remaining flasks to be repaired or replaced.

**CAUTION**

Do not repair flasks that have been damaged beyond inspection criteria stated in Table D-1.

- b. Repair cuts or abrasions less than 0.010 inch in depth and 1.00 inch in length, parallel to flask centerline, as follows:
  - (1) Sand damaged area with 120-grit sandpaper.
  - (2) Clean cut area with fine sandpaper.

### SS500-HK-MMO-010



**Figure 6-12. Flask Removal**

## SS500-HK-MMO-010

- (3) Clean cut area with Methyl Ethyl Ketone (MEK) solvent; dry thoroughly.
  - (4) Cut loose fibers or ends.
  - (5) Carefully following manufacturer's directions on package for use and drying time, fill cut with any of the following commercial two-part epoxy systems: Devcon®, Master Mend®, Duro®, or Loctite®.
  - (6) Using available polyurethane enamel (in original color if possible), repaint repaired area and allow to dry overnight. Do not paint over Department of Transportation (DOT) label.
- c. Install repaired or replacement flask(s) into flask rack assembly in accordance with the following procedure:

**CAUTION**

Handle flask racks and flasks carefully to avoid damage to equipment during removal/installation.

- (1) Ensure flask rack assembly (1) is inverted and straps (6) are loosened.
- (2) Working from open end of flask rack assembly (1), carefully slide flask (7) through straps (6).
- (3) Using the upper portion of Figure 6-12 as a guide, turn flask until flask valve outlet is positioned approximately as shown in the figure. Note that each flask will be positioned differently according to its location within the rack.
- (4) Remove bagging from hose or cross fitting. Install new softseat (Figure 6-15, 3) on hose or cross nipple.
- (5) Remove bagging from flask shutoff valve. While holding 3/4-inch hex nut (Figure 6-12, 3) in place, reinstall and tighten CGA 346 nut (2) to flask shutoff valve. If necessary, slightly reposition the flask valve outlets to achieve the proper fit before tightening the CGA 346 nut.
- (6) Secure both strap assemblies (6) evenly to flask (7) by holding T-bolts (5) with a pair of pliers while tightening nuts (4).
- (7) Repeat steps (2) thru (6) for all remaining flasks.
- (8) Return flask rack assembly to upright position and place in desired location.
- (9) Charge flasks to full working pressure in accordance with approved procedures. Using NID solution prepared in accordance with paragraph 4.7.3.2, pressure test flask connections for leaks and correct as necessary.
- (10) Complete reentry control report and log as appropriate.

## SS500-HK-MMO-010

**6.8.3.2 HP Isolation Valves (AHP-V501, AHP-V502, AHP-V503, AHP-V504).** Two versions of this valve—one made by Circle Seal and the other by CPV—are approved for use with the LWDS MK 3 Mod 0. To allow for differences in design, corrective maintenance for the flask rack assembly HP isolation valves has been divided into two procedures. Removal and replacement of the Circle Seal valve is covered in Procedure A, and removal and repair or replacement of the CPV valve is covered in Procedure B. A slightly different version of these procedures is provided in paragraph 6.8.3.5 to cover removal and installation of AHP-V601 in the roof rack assembly.

### PROCEDURE A: CIRCLE SEAL VALVES

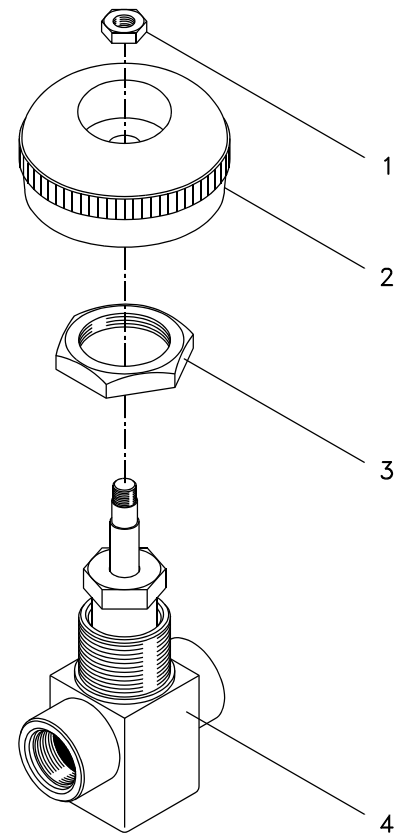
Although corrective maintenance of the Circle Seal valves is limited to removal and replacement in this chapter, repair of the valves is also authorized and can be accomplished using the repair kit in Figure 7-29 and instructions from the manufacturer. In the following procedure, note that all four valves must be removed from the panel but only the damaged/defective valve should be replaced. Unless otherwise noted, refer to Figure 6-13 for parts location and to Figure 7-29 for an index of parts.

#### WARNING

**Approved reentry control must be used for this procedure.**

a. Remove:

- (1) Remove flex hose assemblies from adapter fittings on AHP-V501, -V502, and -V504.
- (2) Remove softseats (Figure 6-15, 3) from the three exposed hose nipples and discard. Bag open ends of hoses H-502 and H-505.
- (3) Remove panel mounting screws, washers, and nuts (three sets) from flask rack assembly panel, and remove panel from rack.
- (4) Remove hex nuts (Figure 6-13, 1) from handles (2) of all four valves, and remove handles from valve stems.
- (5) AHP-V503 only: Loosen union nut and disconnect tubing from positionable elbow. Remove, cut, and discard O-ring.
- (6) Remove panel nuts (3) from all four valves, and remove manifold assembly from panel. Retain valve spacers for later use.



**Figure 6-13. Circle Seal  
HP Isolation Valves  
(AHP-V501 thru AHP-V504  
and AHP-V601)**

## SS500-HK-MMO-010

- (7) Remove damaged/defective valve, along with union connector, from manifold assembly. Remove, cut, and discard O-ring.
  - (8) If replacing AHP-V501, AHP-V502, or AHP-V504: Remove union connector and adapter fitting from valve. If replacing AHP-V503: Remove union connector and positionable elbow from valve.
  - (9) Remove, cut, and discard O-rings, and bag all fittings. Discard valve.
- b. Replace:
- (1) Inspect new valve to ensure that chrome button has been discarded from handle and that valve has been cleaned in accordance with MIL-STD-1330 or another approved NAVSEA cleaning procedure for life support systems.
  - (2) Remove hex nut (1), handle (2), and panel nut (3) from new valve.
  - (3) Using approved lubricant, lubricate two new O-rings (M83248/2-906) and install one on each side of union connector. Install union connector on manifold end of new valve, and install new valve on manifold assembly.
  - (4) Using approved lubricant, lubricate one new O-ring (M83248/2-906). If replacing AHP-V501, AHP-V502, or AHP-V504: Install O-ring on valve end of adapter fitting, and install adapter fitting on valve. If replacing AHP-V503: Install O-ring on valve end of positionable elbow and install elbow on valve.
  - (5) Position manifold assembly behind panel with one valve spacer positioned between each valve and panel. Insert valve bodies (4) through panel, and secure with panel nuts (3).
  - (6) Place handles (2) on valve stems and secure with hex nuts (1).
  - (7) Reinstall panel on flask rack assembly and secure with the three sets of panel mounting screws, washers, and nuts.
  - (8) AHP-V503 only: Using approved lubricant, lubricate new O-ring (M83248/2-111) and install in groove on positionable elbow. Connect tubing to elbow and tighten union nut.
  - (9) For AHP-V501, AHP-V502, and AHP-V504: Install a new softseat (Figure 6-15, 3) on each of the three hose nipples, and connect flexible hose assemblies to valve adapter fittings. (See Figure 7-14 for softseat ordering information.)
  - (10) Pressurize flask rack assembly. Using NID solution prepared in accordance with paragraph 4.7.3.2, check valves and valve connections for leaks and correct as necessary.
  - (11) Complete reentry control report and log.



SS500-HK-MMO-010

**PROCEDURE B: CPV VALVES**

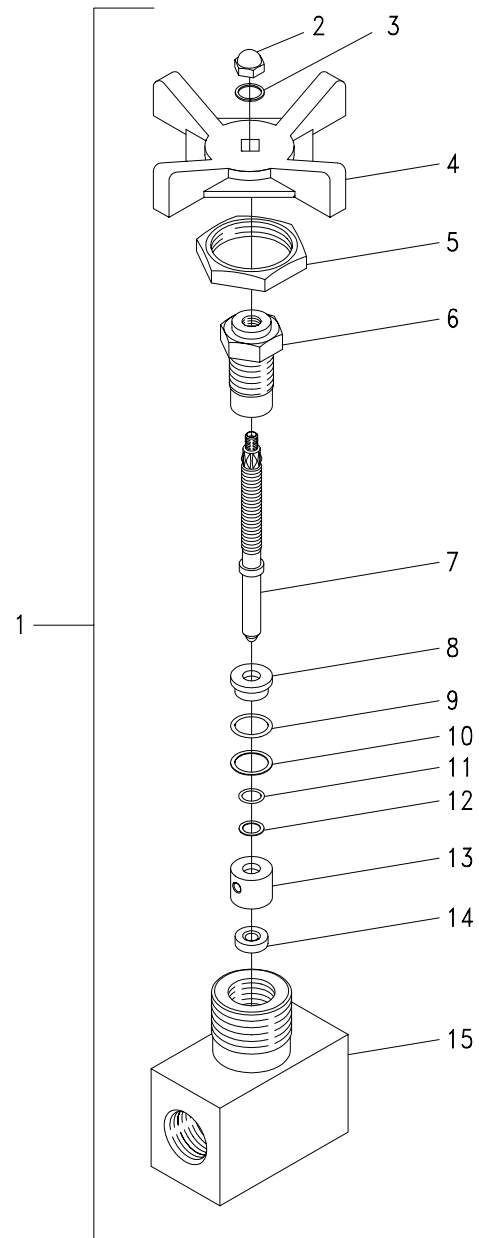
Remove and repair or replace damaged/defective CPV HP isolation valves in accordance with the following procedure. Although all four valves must be removed from the panel for this procedure, only the damaged/defective valve needs to be replaced. Unless otherwise noted, refer to Figure 6-14 for parts location and to Figure 7-28 for an index of parts.

**WARNING**

**Approved reentry control must be used for this procedure.**

## a. Remove:

- (1) Remove flex hose assemblies from valve adapter fittings on AHP-V501, AHP-V502, and AHP-V504.
- (2) Remove softseats (Figure 6-15, 3) from the three exposed hose nipples and discard. Bag open ends of hoses H-502 and H-505.
- (3) Remove panel mounting screws, washers, and nuts (three sets) from flask rack assembly panel; remove panel from rack.
- (4) Remove acorn nuts (Figure 6-14, 2), lock washers (3), and handles (4) from all four valves.
- (5) AHP-V503 only: Loosen union nut and disconnect tubing from positionable elbow. Remove, cut, and discard O-ring.
- (6) Remove panel nuts (5) from all four valves, and remove manifold assembly from panel. Retain valve spacers for later use.
- (7) Remove valve and union connector from manifold assembly. Remove, cut, and discard O-ring.



**Figure 6-14. CPV HP Isolation Valves (AHP-V501 thru AHP-V504 and AHP-V601)**

## SS500-HK-MMO-010

- (8) If replacing AHP-V501, AHP-V502, or AHP-V504: Remove union connector and adapter fitting from valve. If removing AHP-V503: Remove union connector and positionable elbow from valve.
  - (9) Remove, cut, and discard O-rings, and bag all fittings. If repairing valve, continue with step b; otherwise, discard old valve and proceed to step d.
- b. To repair valve, disassemble valve only to extent necessary to make needed repair in accordance with following procedure. If replacement is desired, proceed to step d.
- (1) Remove gland nut (6) from valve body (15).
  - (2) Remove valve stem (7) from gland nut (6).
  - (3) Remove spacer (8) from valve body (15).
  - (4) Remove O-rings (10, 12) and back-up rings (9, 11) from spacer (8). Cut and discard O-rings only.
  - (5) Remove sleeve (13) and disc (14) from valve body (15).
- c. Reassemble repaired valve as follows:
- (1) Install disc (14) and sleeve (13) in valve body (15).
  - (2) Install back-up rings (9, 11) on spacer (8). Using approved lubricant, lubricate new O-rings (10, 12) and install on spacer.
  - (3) Install spacer (8) in valve body (15).
  - (4) Install valve stem (7) in gland nut (6).
  - (5) Install gland nut (6) in valve body (15).
- d. Install repaired or replacement valve as follows:
- (1) For replacement valve only: Ensure valve has been cleaned in accordance with MIL-STD-1330 or another approved NAVSEA cleaning procedure for life support systems. Remove acorn nut (2), lock washer (3), handle (4), and panel nut (5) from new valve (1).
  - (2) Using approved lubricant, lubricate two new O-rings (M83248/2-906) and install one on each side of union connector. Install union connector on manifold end of valve (1), and install valve on manifold assembly.
  - (3) Using approved lubricant, lubricate one new O-ring (M83248/2-906). If replacing AHP-V501, AHP-V502, or AHP-V504: Install O-ring on valve end of adapter fitting, and install adapter fitting on valve. If replacing AHP-V503: Install O-ring on valve end of positionable elbow and install elbow on valve.

## SS500-HK-MMO-010

- (4) Position manifold assembly behind panel with one valve spacer positioned between each valve and panel. Insert valve bodies (15) through panel, and secure with panel nuts (5).
- (5) Install handles (4), lock washers (3), and acorn nuts (2) on all four valves.
- (6) Reinstall panel on flask rack assembly and secure with the three sets of panel mounting screws, washers, and nuts.
- (7) AHP-V503 only: Using approved lubricant, lubricate new O-ring (M83248/2-111) and install in groove on positionable elbow. Connect tubing to elbow and tighten union nut.
- (8) For AHP-V501, AHP-V502, and AHP-V504: Install a new softseat (Figure 6-15, 3) on each of the three hose nipples, and connect flexible hose assemblies to valve adapter fittings. (See Figure 7-14 for softseat ordering information.)
- (9) Pressurize flask rack assembly. Using NID solution prepared in accordance with paragraph 4.7.3.2, check valves and valve connections for leaks and correct as necessary.
- (10) Complete reentry control report and log.

**6.8.3.3 Flask Shutoff Valves (AHP-V505, AHP-V506, AHP-V507).** The following procedure should be used for repairing or replacing the flask shutoff valves. Although the flask shutoff valves are identical for each flask, they are given JID numbers that indicate their position within the flask rack assembly (in left-to-right order). The hose connections are similar for AHP-V505 and AHP-V507, whereas AHP-V506 differs in that it connects to a cross fitting rather than a hose assembly. Repair includes replacing the safety assembly, seat plug, and packing in the valve, and related maintenance includes replacing the softseat that is located on the nipple end of the hose or cross. Refer to Figures 7-14 and 7-25 for replacement parts for the softseat and flask shutoff valves, respectively. The callouts in the following procedure refer to Figure 6-15.

**WARNINGS**

**Approved reentry control must be used for this procedure.**

**Ensure pressure has been bled from HP air flasks before conducting corrective maintenance on the flasks. Failure to comply could result in injury or death to personnel.**

a. Remove:

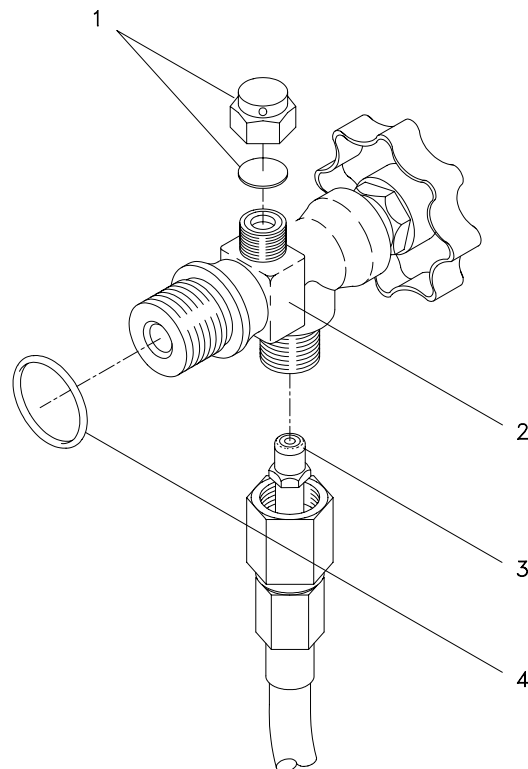
- (1) Remove appropriate flask from flask rack assembly in accordance with step a of paragraph 6.8.3.1, which includes cleaning procedures, bleeding of air from flask, and removal of softseat (3).

## SS500-HK-MMO-010

- (2) Remove bag from shutoff valve (2) and remove shutoff valve from flask. Remove, cut, and discard O-ring (4). Bag valve, unless valve is being discarded.
- (3) Inspect flask in accordance with steps e, f, and g of MRC 8YJH (MIP 5921/171), and repair or replace flask as necessary.

## b. Repair:

- (1) Remove flask shutoff valve (2) from bag, and remove safety assembly (1) from top of valve. Discard safety assembly, which consists of cap and rupture disk.
- (2) Disassemble flask shutoff valve (2) in order shown in Figure 7-25.
- (3) Using the necessary replacement parts, reassemble flask shutoff valve (2) in reverse order of disassembly.
- (4) Install new safety assembly (1) on flask shutoff valve (2). Torque to 45 ft-lb.



**Figure 6-15. Flask Shutoff Valves (AHP-V505, AHP-V506, AHP-V507) and Softseat**

## c. Install repaired or replacement valve:

- (1) Ensure replacement valve has been cleaned in accordance with MIL-STD-1330 or other approved NAVSEA cleaning procedure for life support systems.
- (2) Using approved lubricant, lubricate new O-ring (4, M83248/2-916) and install onto flask shutoff valve (2).
- (3) Install flask shutoff valve (2) into flask. Torque to 75 ft-lb.
- (4) Install flask into flask rack assembly in accordance with step c of paragraph 6.8.3.1, which includes installation of new softseat (3) on hose or cross nipple, flask charging, leak testing, and reentry control.

**6.8.3.4 HP Pressure Gauges (AHP-G508, AHP-G602).** The HP pressure gauges for the HP air supply and roof rack assembly, AHP-G508 and AHP-G602 respectively, have a pressure range of 0-4000 psi, which makes them suitable for use in the LWDS MK 3 Mod 0. Four other gauges of this type, AHP-G211 and AHP-G316, are used in the Mod 0 and Mod 1 volume tank and control console assemblies and feature pressure ranges of 0-4000 psi for the two Mod 0 gauges and 0-6000 psi for the two Mod 1 gauges. Since all six gauges are identical except for the pressure ranges, the following procedure can be used for removal and replacement of all the

## SS500-HK-MMO-010

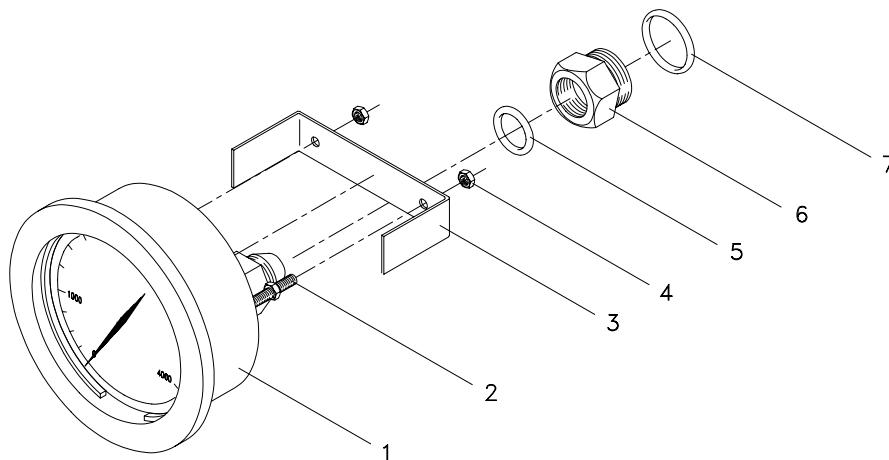
gauges. Refer to Figure 7-18 for an index of replacement parts and to Figure 6-16 for the call-outs used in the procedure below.

### WARNINGS

**Approved reentry control must be used for this procedure. Exercise extreme care when handling pressure gauges. Failure to keep gauges, tools, and parts free of oil, grease, rust, or contaminants may cause damage or inaccurate readings. Failure to observe this warning may result in equipment failure and injury or death to personnel.**

a. Remove:

- (1) Ensure gauge is depressurized.
- (2) For AHP-G602 only: Invert roof rack assembly to allow access to gauge.
- (3) Loosen tubing nut and remove tubing from snubber (6). Remove face seal O-ring (7) from snubber; cut and discard O-ring.
- (4) Remove the two mounting bracket hex nuts (4) and mounting bracket (3).
- (5) Remove gauge (1) from panel.
- (6) Remove the two mounting bracket studs (2) from rear of gauge (1).
- (7) Remove snubber (6) and O-ring (5) from gauge stem. Cut and discard O-ring.



**Figure 6-16. HP Pressure Gauges (AHP-G211, AHP-G316, AHP-G508, and AHP-G602)**

## SS500-HK-MMO-010

(8) Bag all open fittings and removed parts. If gauge is to be calibrated, tag and bag gauge in accordance with approved procedures and send to authorized calibration facility.

b. Replace:

- (1) Ensure replacement gauge shows current calibration date and has been cleaned in accordance with MIL-STD-1330 or other approved NAVSEA cleaning procedure for life support systems.
- (2) Install mounting bracket studs (2) on replacement gauge (1).
- (3) Using approved lubricant, lubricate new O-ring (5, M83248/2-904). Install O-ring and snubber (6) on gauge stem.
- (4) Using approved lubricant, lubricate new face seal O-ring (7, M83248/2-113) and install in O-ring groove on snubber (6). If installing new snubber, discard vendor-supplied O-ring before installing O-ring (7) and ensure snubber has been cleaned in accordance with MIL-STD-1330 or other approved NAVSEA cleaning procedure for life support systems.

**WARNING**

**Ensure gauge is securely installed. Failure to tighten gauge securely may result in damage to equipment and injury or death to personnel.**

- (5) Position gauge (1) in panel, and secure mounting bracket (3) to gauge with the two hex nuts (4).
- (6) Align tubing with snubber (6) and secure with tubing nut.
- (7) Pressurize gauge. Using NID solution prepared in accordance with paragraph 4.7.3.2, check gauge connections for leaks and correct as necessary.
- (8) For AHP-G602 only: Return roof rack assembly to upright position.
- (9) Complete reentry control report and log.

**6.8.3.5 HP Isolation Valve (AHP-V601).** Although this valve is identical to the HP air supply valves referenced in paragraph 6.8.3.2 (AHP-V501, -V502, -V503, -V504), its location in the roof rack assembly requires a different procedure for removal and replacement. Two versions of this valve—one made by Circle Seal and the other by CPV—are approved for use with the LWDS MK 3 Mod 0. To allow for differences in design, corrective maintenance for the roof rack HP isolation valve has been divided into two procedures. Removal and replacement of the Circle Seal valve is covered in Procedure A, and removal and repair or replacement of the CPV valve is covered in Procedure B.

## SS500-HK-MMO-010

**PROCEDURE A: CIRCLE SEAL VALVE**

Although corrective maintenance of the Circle Seal valves is limited to removal and replacement in this chapter, repair of the valves is also authorized and can be accomplished using the repair kit in Figure 7-29 and instructions from the manufacturer. Unless otherwise noted, refer to Figure 6-13 for parts location and to Figure 7-29 for an index of parts.

**WARNING**

**Approved reentry control must be used for this procedure.**

## a. Remove:

- (1) Invert roof rack assembly.
- (2) Remove hex nut (1) from handle (2), and remove handle from valve stem.
- (3) Loosen gland nuts on each side of valve and disconnect tubing from male connectors. Remove, cut, and discard connector O-rings. Bag open ends of tubing.
- (4) Remove panel nut (3) from valve body (4). Remove valve body from panel. Retain valve spacer for later use.
- (5) Remove male connectors from valve body (4). Remove, cut, and discard connector O-rings, and bag connectors. Discard valve.

## b. Replace:

- (1) Inspect new valve to ensure that chrome button has been discarded from handle and that valve has been cleaned in accordance with MIL-STD-1330 or another approved NAVSEA cleaning procedure for life support systems.
- (2) Remove hex nut (1), handle (2), and panel nut (3) from new valve.
- (3) Using approved lubricant, lubricate two new O-rings (M83248/2-906) and install on valve end of male connectors.
- (4) Install male connectors in new valve. Connectors should be tightened only until no leakage is observed when tightness test is performed in step (8).
- (5) Positioning valve spacer between valve and panel, place valve body (4) through panel and secure with panel nut (3).
- (6) Using approved lubricant, lubricate two new O-rings (M83248/2-010) and install in grooves of male connectors. Connect tubing glands to male connectors and tighten gland nuts 3/8 to 1/2 turn after O-ring engagement.
- (7) Place handle (2) over valve stem, and secure with hex nut (1).

## SS500-HK-MMO-010

- (8) Pressurize roof rack assembly. Using NID solution prepared in accordance with paragraph 4.7.3.2, check valve connections for leaks and correct as necessary.
- (9) Complete reentry control report and log.

**PROCEDURE B: CPV VALVE**

Remove and repair or replace damaged/defective CPV HP isolation valve AHP-V601 in accordance with the following procedure. Unless otherwise noted, refer to Figure 6-14 for parts location and to Figure 7-28 for part numbers.

**WARNING**

**Approved reentry control must be used for this procedure.**

- a. Remove:
  - (1) Invert roof rack assembly.
  - (2) Remove acorn nut (2), lock washer (3), and handle (4) from valve stem (7).
  - (3) Loosen gland nuts on each side of valve and disconnect tubing from male connectors. Remove, cut, and discard connector O-rings. Bag open ends of tubing.
  - (4) Remove panel nut (5) from valve body (15). Remove valve body from panel. Retain valve spacer for later use.
  - (5) Remove male connectors from valve body (15). Remove, cut, and discard connector O-rings, and bag connectors. Discard valve if not being repaired.
- b. To repair valve, disassemble valve only to extent necessary to make needed repair in accordance with the following. To replace valve, proceed to step d.
  - (1) Remove gland nut (6) from valve body (15).
  - (2) Remove valve stem (7) from gland nut (6).
  - (3) Remove spacer (8) from valve body (15).
  - (4) Remove O-rings (10, 12) and back-up rings (9, 11) from spacer (8). Cut and discard O-rings only.
  - (5) Remove sleeve (13) and disc (14) from valve body (15).
- c. Reassemble repaired valve as follows:
  - (1) Install disc (14) and sleeve (13) in valve body (15).



## SS500-HK-MMO-010

- (2) Install back-up rings (9, 11) on spacer (8). Using approved lubricant, lubricate new O-rings (10, 12) and install on spacer.
  - (3) Install spacer (8) in valve body (15).
  - (4) Install valve stem (7) in gland nut (6).
  - (5) Install gland nut (6) in valve body (15).
- d. Install repaired or replacement valve as follows:
- (1) New valve only: Ensure valve has been cleaned in accordance with MIL-STD-1330 or other approved NAVSEA cleaning procedure for life support systems.
  - (2) New valve only: Remove acorn nut (2), lock washer (3), handle (4), and panel nut (5) from new valve (1).
  - (3) Using approved lubricant, lubricate two new O-rings (M83248/2-906) and install on valve end of male connectors.
  - (4) Install male connectors in valve body (15). Connectors should be tightened only until no leakage is observed when tightness test is performed in step (8).
  - (5) Positioning valve spacer between valve and panel, place valve body (15) through panel and secure with panel nut (5).
  - (6) Using approved lubricant, lubricate two new O-rings (M83248/2-010) and install in grooves of male connectors. Connect tubing glands to male connectors and tighten gland nuts 3/8 to 1/2 turn after O-ring engagement.
  - (7) Install handle (4), lock washer (3), and acorn nut (2) on valve stem (7).
  - (8) Pressurize roof rack assembly. Using NID solution prepared in accordance with paragraph 4.7.3.2, check valve connections for leaks and correct as necessary.
  - (9) Complete reentry control report and log.

**6.8.3.6 HP Relief Valve (AHP-V603).** Corrective maintenance for roof rack HP relief valve (AHP-V603) is limited to removal of the old valve and modification and installation of the new valve. Modification of the new valve is required as R3A valves are supplied by the manufacturer without a spring and must be fitted with a color-coded spring that corresponds to the required cracking pressure range. Since AHP-V603 requires a cracking pressure range of 3,000-4,000 psig, a white spring kit (PN 177-R3A-K1-F) should be ordered at the same time as the valve (see Figure 7-36 for index of replacement parts). Also, because the same basic valve is used for both AHP-V603 and ALP-V404 (compressor LP relief valve), AHP-V603 can be modified with a blue spring kit and a manual override handle kit to make it suitable for use as ALP-V404. See paragraph 6.8.2.8 for a comparison of the valves and instructions for converting AHP-V603 for use as ALP-V404. Refer to Table 2-4 and Figure 2-4 for valve location and to Figure 7-36 for an index of replacement parts. The callouts in the following procedure refer to Figure 6-17.

SS500-HK-MMO-010

**WARNING****Approved reentry control must be used for this procedure.**

## a. Remove:

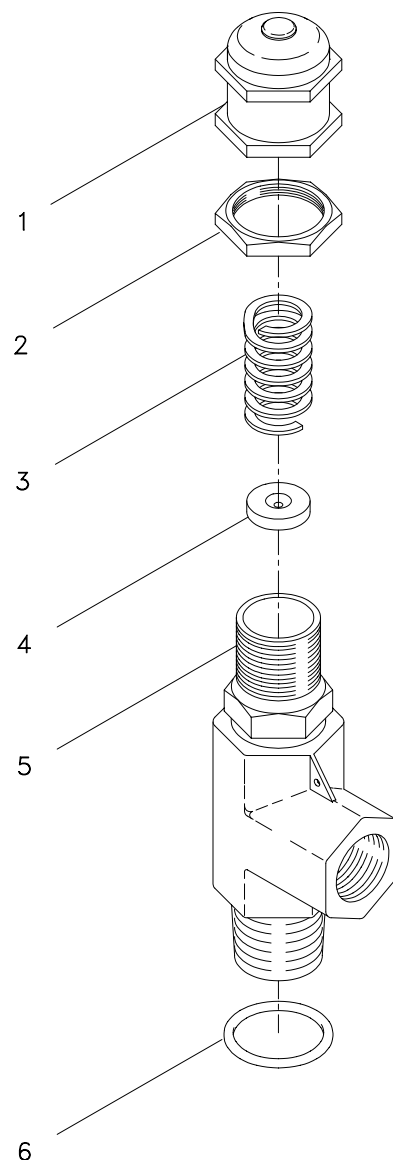
- (1) Invert roof rack assembly to allow access to valve.
- (2) Remove relief valve from cross fitting, and discard relief valve and O-ring (6). Bag opening in cross fitting.

## b. Prepare new valve for installation as follows:

- (1) Remove adjustment cap (1) from bonnet (5). Install spring support disc (4) and white spring (3) from spring kit (PN 177-R3A-K1-F). Reassemble valve in accordance with installation instructions included in spring kit.
- (2) Clean modified valve in accordance with MIL-STD-1330 or other approved NAVSEA cleaning procedure for life support systems.
- (3) Set valve to relieve at 3,300 psi by turning adjustment cap (1) clockwise until correct setting is obtained. Lock cap in place with locking nut (2) and secure with lockwire from spring kit.

## c. Install modified valve:

- (1) Using approved lubricant, lubricate new O-ring (6, M83248/2-906) and install on threads of new relief valve.
- (2) Remove bagging from cross fitting, and install new relief valve.
- (3) Apply pressure and test valve for leaks using NID solution prepared in accordance with paragraph 4.7.3.2. Correct leaks as necessary.
- (4) Return roof rack assembly to upright position.
- (5) Complete reentry control report and log.

**Figure 6-17. HP Relief Valve (AHP-V603)**

## SS500-HK-MMO-010

**6.8.3.7 HP Isolation Valve (AHP-V604).** The roof rack HP isolation valve (AHP-V604) is one of seven identical valves used in the LWDS MK 3 Mod 0. Other valves of this type include LP gauge isolation valves ALP-V204 in the volume tank assembly and ALP-V301, -V310, -V312, -V313, and -V314 in the control console assembly. Although this valve has a working pressure of 6,000 psi, it is used for both HP and LP applications in the system. The major difference in removal and installation procedures for all seven valves involves the type of fittings that are used for connection. AHP-V604, ALP-V301, and ALP-V310 are connected by tubing nuts at each end. ALP-V204 is connected by a tubing nut at the top and by an adapter at the bottom. ALP-V312, -V313, and -V314 are connected by a tubing nut at the top and by a coupler to a tee at the bottom. Corrective maintenance for ALP-V204 is presented in paragraph 6.8.4.3 and corrective maintenance for ALP-V301, -V310, -V312, -V313, and -V314 is presented in paragraph 6.8.5.2 with references to the repair procedures provided in this paragraph.

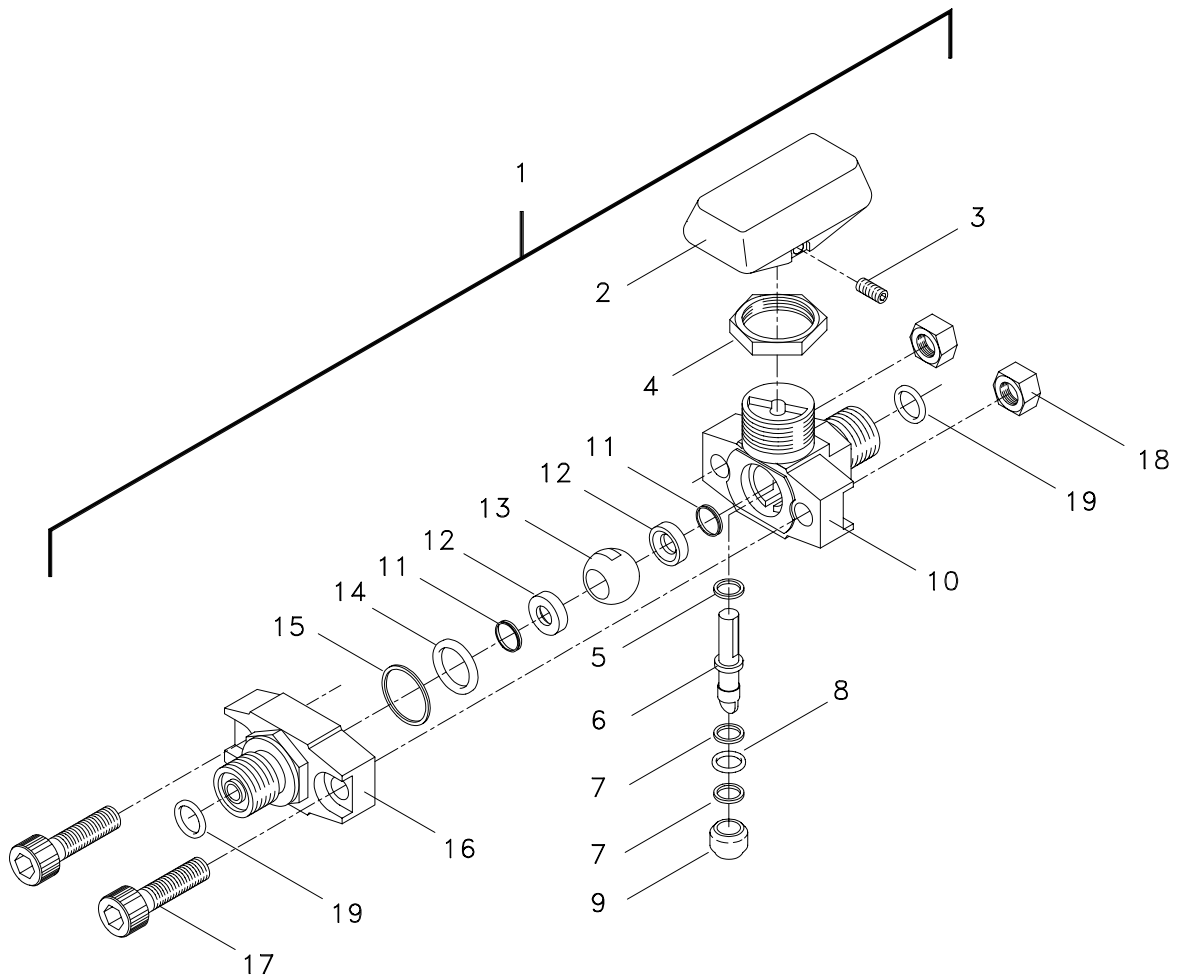
Remove and repair or replace roof rack HP isolation valve (AHP-V604) in accordance with the following procedure. The callouts in the procedure refer to Figure 6-18, and the part numbers for replacement parts can be found in Figure 7-27.

**WARNING**

**Approved reentry control must be used for this procedure.**

- a. Remove:
  - (1) Invert roof rack assembly to allow access to valve (1).
  - (2) Loosen tubing nuts and remove tubing from both ends of valve (1).
  - (3) Using an Allen wrench, loosen setscrew (3) and remove handle (2) from stem (6).
  - (4) Remove panel nut (4) from valve (1), and remove valve from panel. Remove, cut, and discard face seal O-rings (19).
- b. Repair:
  - (1) Disassemble:
    - (a) Using 1/4-inch Allen wrench, remove both socket head bolts (17) and hex nuts (18) from valve assembly.
    - (b) Remove body half (16) from body half (10).
    - (c) Remove, cut, and discard end piece back-up ring (15), seat quad ring (11), seat (12), and end piece O-ring (14).
    - (d) Rotate stem (6) until stem ball (13) is in closed position. Remove stem ball (13) through opening on side of body half (10).

## SS500-HK-MMO-010



**Figure 6-18. HP Isolation Valve (AHP-V604) and LP Gauge Isolation Valves (ALP-V204, ALP-V301, ALP-V310, ALP-V312, ALP-V313, and ALP-V314)**

- (e) Press stem (6) through cavity opening in body half (10) until stem bushing (9) will clear cavity opening. Remove and discard stem bushing (9).
- (f) Align stem (6) with cavity notch in body half (10) and remove stem from housing assembly.
- (g) Remove both stem back-up rings (7) and stem O-ring (8) from stem (6). Cut and discard back-up rings and O-ring.
- (h) Remove seat quad ring (11) and seat (12) from body half (10). Cut and discard ring and seat.
- (i) Remove stem bearing (5) from body half (10). Cut and discard stem bearing.

## SS500-HK-MMO-010

## (2) Reassemble:

- (a) Install replacement seat quad ring (11) and seat (12) in body half (10).
- (b) Install replacement stem bearing (5) on upper part of stem (6).
- (c) Using approved lubricant, lubricate replacement stem back-up rings (7) and stem O-ring (8) and install on stem (6).
- (d) Install stem assembly through opening in body half (10). Align lower part of stem (6) with notch in body cavity. Insert top of stem (6) into upper portion of body half (10) and place lower stem bushing (9) onto stem. Press stem bushing upward until fully seated in body half.
- (e) Position stem (6) so that stem ball (13) can be installed on bottom of stem inside body half (10). Rotate stem to ensure stem ball is installed properly.
- (f) Install replacement seat quad ring (11) and seat (12) in body half (16).
- (g) Using approved lubricant, lubricate replacement end piece back-up ring (15) and end piece O-ring (14) and install on body half (16).
- (h) Secure body half (16) to body half (10) with two socket head bolts (17) and hex nuts (18). Tighten securely.

## c. Install repaired or replacement valve:

- (1) New valves only: Using an Allen wrench, loosen setscrew (3) and remove handle (2) from valve stem. Remove panel nut (4) from valve. Remove, cut, and discard vendor-supplied O-rings. Ensure valve has been cleaned in accordance with MIL-STD-1330 or other approved NAVSEA cleaning procedure for life support systems.
- (2) Using approved lubricant, lubricate replacement O-rings (19, M83248/2-010) and install one O-ring in each end fitting on body halves (10, 16).
- (3) Position valve through panel, and secure with panel nut (4).
- (4) Install and secure handle (2) to stem (6) by tightening setscrew (3) to stem.
- (5) Install tubing to both ends of valve (1) and secure with tubing nuts.
- (6) Pressurize roof rack assembly and check valve connections for leaks using NID solution prepared in accordance with paragraph 4.7.3.2. Correct leaks as necessary.
- (7) Return roof rack assembly to upright position.
- (8) Complete reentry control report and log.

## SS500-HK-MMO-010

**6.8.4 Volume Tank Assembly.** Corrective maintenance for the volume tank assembly consists of repair or replacement of the following components. Valve and gauge JID numbers are shown in parentheses and page numbers are shown flush right.

- Para. 6.8.4.1—HP Regulator (AHP-V201) . . . . . Pg 6-57
- Para. 6.8.4.2—HP Gauge Isolation Valve (AHP-V202) . . . . . Pg 6-64
- Para. 6.8.4.3—LP Gauge Isolation Valve (ALP-V204) . . . . . Pg 6-67
- Para. 6.8.4.4—Plug Valves (ALP-V205, -V208, -V209) . . . . . Pg 6-68
- Para. 6.8.4.5—Check Valve (ALP-V206) . . . . . Pg 6-69
- Para. 6.8.4.6—LP Relief Valves (ALP-V207, -V211) . . . . . Pg 6-70
- Para. 6.8.4.7—Ball Valve (ALP-V210) . . . . . Pg 6-71
- Para. 6.8.4.8—Mod 0 and Mod 1 HP Pressure Gauges (AHP-G211) . . . . . Pg 6-72
- Para. 6.8.4.9—LP Pressure Gauge (ALP-G212) . . . . . Pg 6-73

**6.8.4.1 HP Regulator (AHP-V201).** There are two identical HP regulators in the LWDS MK 3 Mod 0—AHP-V201 in the volume tank assembly and AHP-V307 in the control console assembly. To allow for differences in removal and replacement, corrective maintenance for AHP-V201 is presented here and corrective maintenance for AHP-V307 is provided in paragraph 6.8.5.5. Since two versions of the regulator—one made by Circle Seal and the other by Tescom—are approved for use in the LWDS MK 3 Mod 0, corrective maintenance has been further divided in each paragraph and the resulting procedures are identified according to the manufacturer: Procedure A for the Circle Seal regulator and Procedure B for the Tescom regulator. Corrective maintenance of the Circle Seal regulator is limited to removal and replacement at the organizational level; therefore, any Circle Seal regulator in need of repair should be sent to an authorized repair facility for overhaul. Tescom regulators may be removed and replaced or repaired locally if the capability for such repair exists at the organizational level.

#### **PROCEDURE A: CIRCLE SEAL REGULATOR**

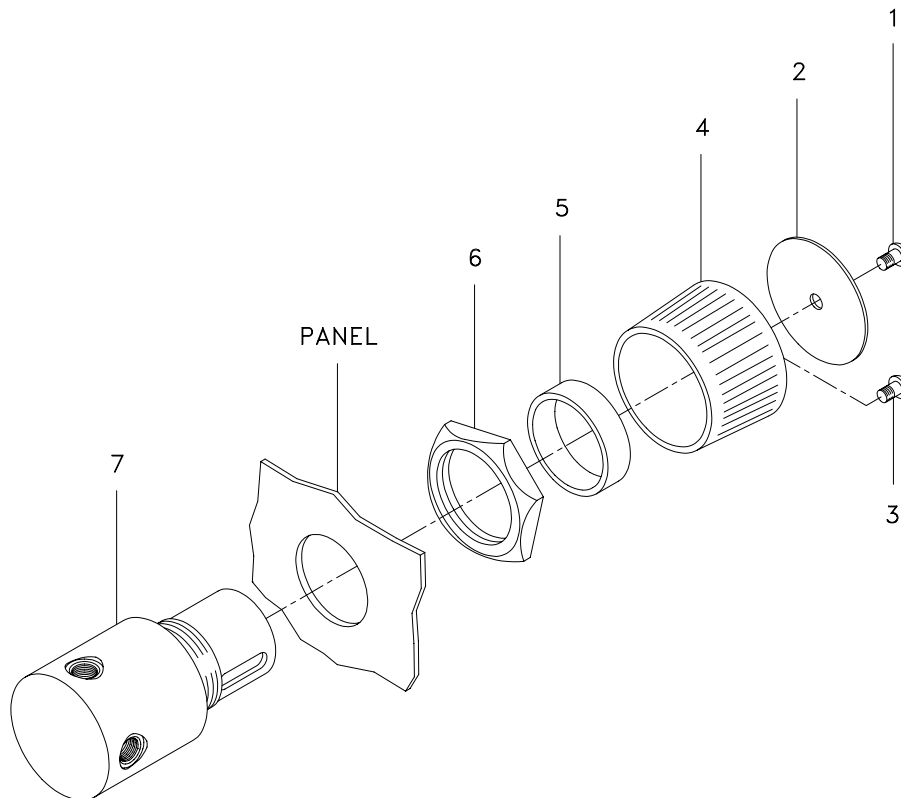
Remove and replace damaged/defective Circle Seal HP regulator (AHP-V201) in accordance with the following procedure. Unless otherwise noted, refer to Figure 6-19 for parts location and to Figure 7-33 for an index of replacement parts. If repair is desired, send regulator to an authorized repair facility for overhaul.

#### **WARNING**

**Approved reentry control must be used for this procedure.**

- a. Remove:
  - (1) Bleed pressure from volume tank.
  - (2) Using 3/32-inch Allen wrench, remove cap retaining screw (1) from center of regulator handle (4) on control panel.
  - (3) Using sturdy tool with flat tip, pry data plate (2) from handle (4).

## SS500-HK-MMO-010



**Figure 6-19. Circle Seal HP Regulators  
(AHP-V201, AHP-V307)**

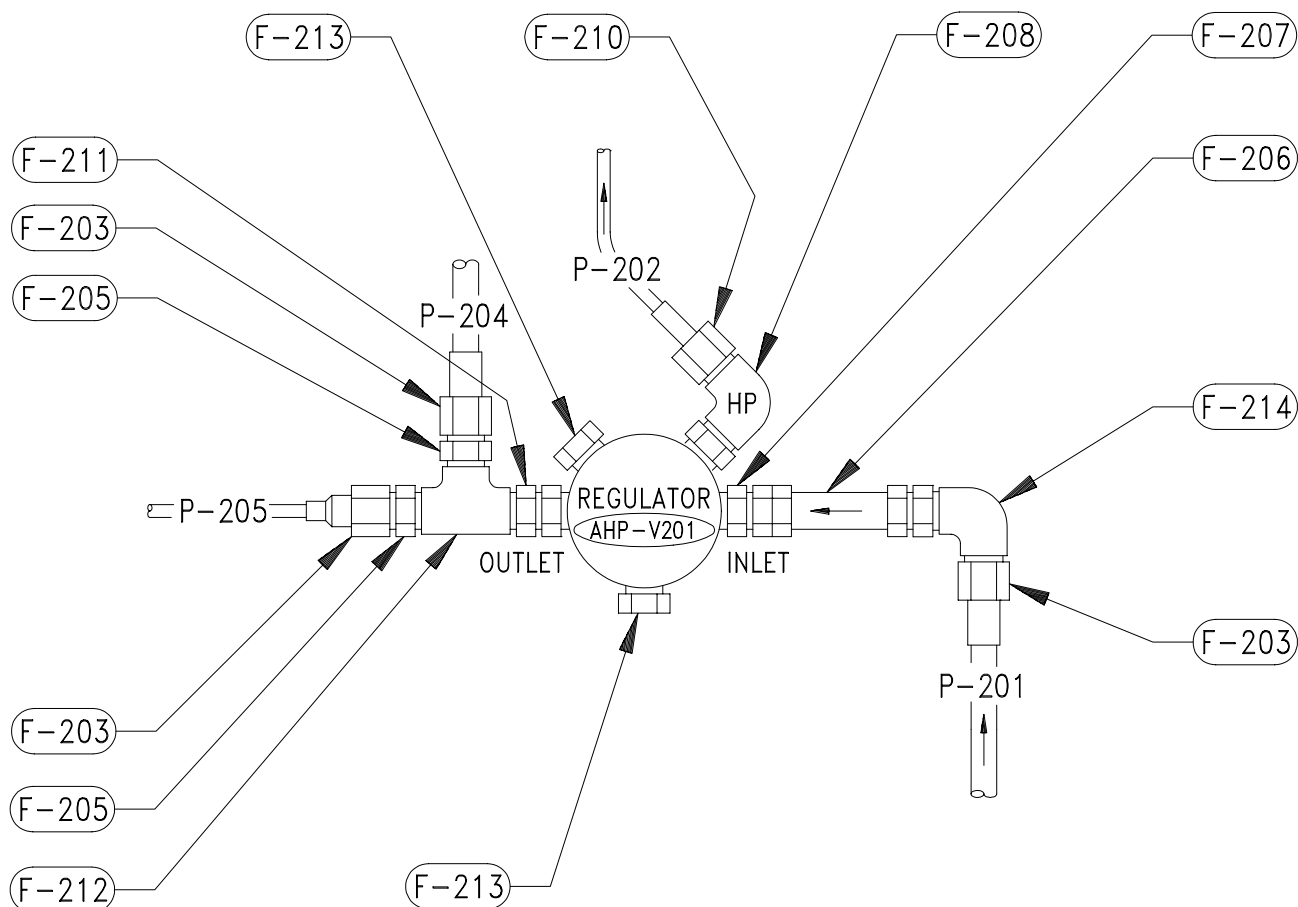
- (4) Using 1/8-inch Allen wrench, remove the three handle retaining screws (3) from handle (4). Remove handle.
- (5) Remove rubber sleeve (5) from housing (7).

**NOTE**

Refer to Figure 6-20 for the location of parts called out in Steps (6) thru (8) and (10) thru (13). Figure 6-20 reflects a portion of the volume tank assembly schematic found on JID 6314821, sheet 3.

- (6) **AT INLET PORT ELBOW (F-214):** Loosen tubing nut (F-203) and remove tubing (P-201) from elbow (F-214). Bag open end of tubing.
- (7) **AT HP GAUGE PORT ELBOW (F-208):** Loosen tubing nut (F-210) and remove tubing (P-202) from elbow (F-208). Bag open end of tubing.
- (8) **AT OUTLET PORT TEE (F-212):** At top of tee (F-212), loosen tubing nut (F-203) and remove tubing (P-204) from tee adapter (F-205). At left side of tee (F-212), loosen tubing nut (F-203) and remove tubing (P-205) from tee adapter (F-205). Bag open ends of tubing.

## SS500-HK-MMO-010



**Figure 6-20. Location of Parts Attached to Regulator (AHP-V201)**

- (9) While maintaining a firm hold on the regulator, remove panel nut (Figure 6-19, 6) from housing (7). Carefully remove regulator with fittings still attached.
- (10) **AT INLET PORT:** Loosen nut on regulator end of positionable union (F-207) in counterclockwise direction and remove union, HP supply air filter (F-206), and elbow (F-214) as a unit from regulator inlet port. Remove, cut, and discard exposed union O-ring (M83248/2-908) and elbow face seal O-ring (M83248/2-111). Bag removed components as a unit or bag open ends.
- (11) **AT HP GAUGE PORT:** Remove elbow (F-208) from regulator HP gauge port. Remove O-ring (M83248/2-904) and face seal O-ring (M83248/2-010) from elbow; cut and discard O-rings. Bag elbow.
- (12) **AT OUTLET PORT:** Loosen nut on regulator end of positionable union (F-211) and remove tee (F-212) with attached fittings from regulator outlet port. Remove O-ring (M83248/2-908) from positionable union and face seal O-ring (M83248/2-111) from both tee adapters (F-205); cut and discard O-rings. Bag tee and all attached fittings.



## SS500-HK-MMO-010

- (13) **AT LP GAUGE AND VENT PORTS:** Remove bleeder plugs (F-213) from regulator vent port and unused LP gauge port. Remove, cut, and discard plug O-rings (M83248/2-904). Bag bleeder plugs.
- (14) Tag and bag removed regulator in accordance with approved procedures and send to an authorized repair facility for overhaul.

b. Install replacement regulator as follows:

- (1) Ensure replacement regulator has been cleaned in accordance with MIL-STD-1330 or other approved NAVSEA cleaning procedure for life support systems.

**NOTE**

Refer to Figure 6-20 for location of components called out in Steps (2) thru (8) and (10) thru (12).

- (2) **AT LP GAUGE AND VENT PORTS:** Remove bagging from the two bleeder plugs (F-213). Using approved lubricant, lubricate two new O-rings (M83248/2-904) and install on bleeder plugs (F-213). Install bleeder plugs in regulator vent port and unused LP gauge port.
- (3) **AT OUTLET PORT:** Remove bagging from tee (F-212). Using approved lubricant, lubricate one new O-ring (M83248/2-908) and install on positionable union (F-211). Install positionable union end of tee (F-212) in regulator outlet port. Tighten union nut.
- (4) Using approved lubricant, lubricate two new face seal O-rings (M83248/2-111) and install in O-ring grooves in tee adapters (F-205).
- (5) **AT HP GAUGE PORT:** Remove bagging from elbow (F-208). Using approved lubricant, lubricate one new O-ring (M83248/2-904) and install on straight threads of elbow (F-208). Install elbow in regulator HP gauge port.
- (6) Using approved lubricant, lubricate one new face seal O-ring (M83248/2-010) and install in O-ring groove in elbow (F-208).
- (7) **AT INLET PORT:** Remove bagging from positionable union (F-207), HP supply air filter (F-206), and elbow (F-214). Using approved lubricant, lubricate one new O-ring (M83248/2-908) and install on positionable union (F-207). Install end with positionable union (F-207) in regulator inlet port and tighten union nut.
- (8) Using approved lubricant, lubricate one new face seal O-ring (M83248/2-111) and install in O-ring groove in elbow (F-214).
- (9) Insert regulator through rear opening in panel, then reach around panel and install panel nut (Figure 6-19, 6) on housing (7). To maintain correct positioning of ports, hold regulator securely while tightening panel nut.

## SS500-HK-MMO-010

- (10) **AT OUTLET PORT TEE (F-212):** Remove bagging from tubing (P-205), and install tubing to tee adapter (F-205) located on left side of tee (F-212). Tighten tubing nut (F-203). Remove bagging from tubing (P-204), and install tubing to tee adapter (F-205) located on top of tee (F-212). Tighten tubing nut (F-203).
- (11) **AT HP GAUGE PORT ELBOW (F-208):** Remove bagging from tubing (P-202) and install tubing to elbow (F-208). Tighten tubing nut (F-210).
- (12) **AT INLET PORT ELBOW (F-214):** Remove bagging from tubing (P-201) and install tubing to elbow (F-214). Tighten tubing nut (F-203).
- (13) At front of panel, install rubber sleeve (Figure 6-19, 5) on housing (7).
- (14) Install handle (4) on housing (7). Using 1/8-inch Allen wrench, secure handle with the three handle retaining screws (3).
- (15) Insert data plate (2) in handle (4). Using 3/32-inch Allen wrench, secure data plate with cap retaining screw (1).
- (16) Apply pressure to volume tank assembly from primary HP air source. Operate regulator through turning arc and leak test using NID solution prepared in accordance with paragraph 4.7.3.2. Correct leaks as necessary.
- (17) Complete reentry control report and log.

**PROCEDURE B: TESCOM REGULATOR**

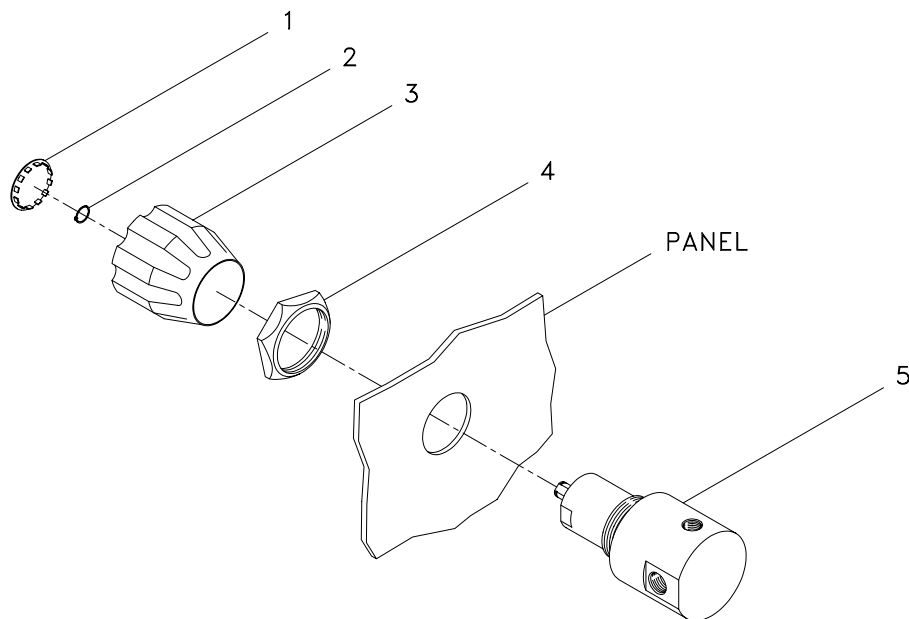
Corrective maintenance for Tescom HP regulator (AHP-V201) includes removal and replacement, or repair if the capability for such repair exists at the organizational level. For removal and replacement, follow the procedure provided below, and unless otherwise noted, refer to Figure 6-21 for parts location and to Figure 7-34 for an index of replacement parts. For repair guidance, refer to the manufacturer's technical documentation and to the illustrated parts breakdown in Figure 7-34.

**WARNING**

**Approved reentry control must be used for this procedure.**

- a. Remove:
  - (1) Bleed pressure from volume tank.
  - (2) Using flat-tip screwdriver, pry hole plug (1) from hand knob (3).
  - (3) Using external snap-ring pliers, remove retaining ring (2) from adjusting screw assembly (not shown). Remove hand knob (3).

## SS500-HK-MMO-010



**Figure 6-21. Tescom HP Regulators (AHP-V201, AHP-V307)**

**NOTE**

Refer to Figure 6-20 for the location of parts called out in Steps (4) thru (6) and (8) thru (11). Figure 6-20 reflects a portion of the volume tank assembly schematic found on sheet 3 of JID 6314821.

- (4) **AT INLET PORT ELBOW (F-214):** Loosen tubing nut (F-203) and remove tubing (P-201) from elbow (F-214). Bag open end of tubing.
- (5) **AT HP GAUGE PORT ELBOW (F-208):** Loosen tubing nut (F-210) and remove tubing (P-202) from elbow (F-208). Bag open end of tubing.
- (6) **AT OUTLET PORT TEE (F-212):** At top of tee (F-212), loosen tubing nut (F-203) and remove tubing (P-204) from tee adapter (F-205). At left side of tee (F-212), loosen tubing nut (F-203) and remove tubing (P-205) from tee adapter (F-205). Bag open ends of tubing.
- (7) While maintaining a firm hold on the regulator, remove panel nut (Figure 6-21, 4) from housing (5). Carefully remove regulator with fittings still attached.
- (8) **AT INLET PORT:** Loosen nut on regulator end of positionable union (F-207) in counterclockwise direction and remove union, HP supply air filter (F-206), and elbow (F-214) as a unit from regulator inlet port. Remove, cut, and discard exposed union O-ring (M83248/2-908) and elbow face seal O-ring (M83248/2-111). Bag removed components as a unit or bag open ends.

## SS500-HK-MMO-010

- (9) **AT HP GAUGE PORT:** Remove elbow (F-208) from regulator HP gauge port. Remove O-ring (M83248/2-904) and face seal O-ring (M83248/2-010) from elbow; cut and discard O-rings. Bag elbow.
  - (10) **AT OUTLET PORT:** Loosen nut on regulator end of positionable union (F-211) and remove tee (F-212) with attached fittings from regulator outlet port. Remove O-ring (M83248/2-908) from positionable union and face seal O-ring (M83248/2-111) from both tee adapters (F-205); cut and discard O-rings. Bag tee and all attached fittings.
  - (11) **AT LP GAUGE AND VENT PORTS:** Remove bleeder plugs (F-213) from regulator vent port and unused LP gauge port. Remove, cut, and discard plug O-rings (M83248/2-904). Bag bleeder plugs.
  - (12) Tag and bag removed regulator in accordance with approved procedures and send to an authorized repair facility for overhaul, or repair locally. Local repair is authorized if the capability for such repair exists at the organizational level. For repair guidance, refer to the manufacturer's technical documentation and to the illustrated parts breakdown in Figure 7-34.
- b. Install replacement regulator as follows:
- (1) Ensure replacement regulator has been cleaned in accordance with MIL-STD-1330 or other approved NAVSEA cleaning procedure for life support systems.

**NOTE**

Refer to Figure 6-20 for location of components called out in Steps (2) thru (8) and (10) thru (12).

- (2) **AT LP GAUGE AND VENT PORTS:** Remove bagging from the two bleeder plugs (F-213). Using approved lubricant, lubricate two new O-rings (M83248/2-904) and install on bleeder plugs (F-213). Install bleeder plugs in regulator vent port and unused LP gauge port.
- (3) **AT OUTLET PORT:** Remove bagging from tee (F-212). Using approved lubricant, lubricate one new O-ring (M83248/2-908) and install on positionable union (F-211). Install positionable union end of tee (F-212) in regulator outlet port. Tighten union nut.
- (4) Using approved lubricant, lubricate two new face seal O-rings (M83248/2-111) and install in O-ring grooves in tee adapters (F-205).
- (5) **AT HP GAUGE PORT:** Remove bagging from elbow (F-208). Using approved lubricant, lubricate one new O-ring (M83248/2-904) and install on straight threads of elbow (F-208). Install elbow in regulator HP gauge port.

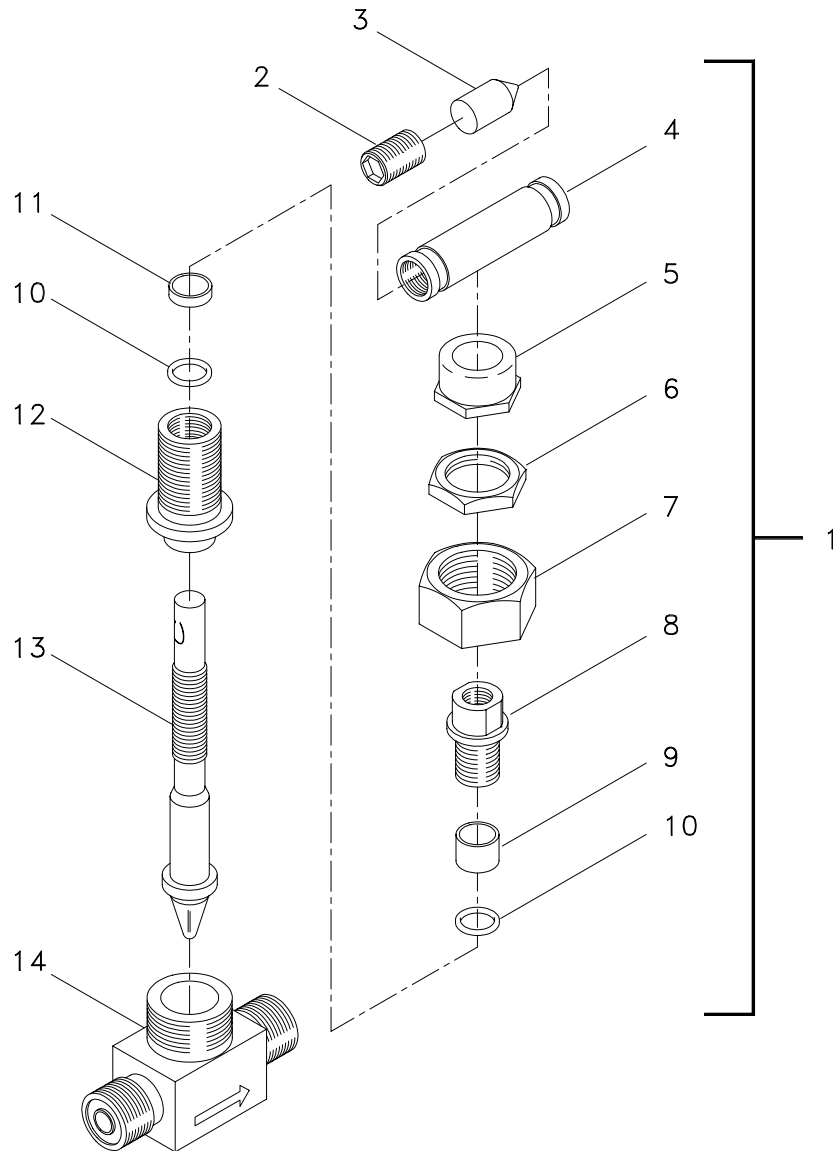
## SS500-HK-MMO-010

- (6) Using approved lubricant, lubricate one new face seal O-ring (M83248/2-010) and install in O-ring groove in elbow (F-208).
- (7) **AT INLET PORT:** Remove bagging from positionable union (F-207), HP supply air filter (F-206), and elbow (F-214). Using approved lubricant, lubricate one new O-ring (M83248/2-908) and install on positionable union (F-207). Install end with positionable union (F-207) in regulator inlet port and tighten union nut.
- (8) Using approved lubricant, lubricate one new face seal O-ring (M83248/2-111) and install in O-ring groove in elbow (F-214).
- (9) Insert regulator through rear opening in panel, then reach around panel and install panel nut (Figure 6-21, 4) on housing (5). To maintain correct positioning of ports, hold regulator securely while tightening panel nut.
- (10) **AT OUTLET PORT TEE (F-212):** Remove bagging from tubing (P-205), and install tubing to tee adapter (F-205) located on left side of tee (F-212). Tighten tubing nut (F-203). Remove bagging from tubing (P-204), and install tubing to tee adapter (F-205) located on top of tee (F-212). Tighten tubing nut (F-203).
- (11) **AT HP GAUGE PORT ELBOW (F-208):** Remove bagging from tubing (P-202) and install tubing to elbow (F-208). Tighten tubing nut (F-210).
- (12) **AT INLET PORT ELBOW (F-214):** Remove bagging from tubing (P-201) and install tubing to elbow (F-214). Tighten tubing nut (F-203).
- (13) At front of panel, install hand knob (Figure 6-21, 3) on housing (5). Insert retaining ring (2) into adjusting screw assembly (not shown).
- (14) Install hole plug (1) into hand knob (3).
- (15) Apply pressure to volume tank assembly from primary HP air source. Operate regulator through turning arc and leak test using NID solution prepared in accordance with paragraph 4.7.3.2. Correct leaks as necessary.
- (16) Complete reentry control report and log.

**6.8.4.2 HP Gauge Isolation Valve (AHP-V202).** AHP-V202, which is one of two identical HP gauge isolation valves found in the system, is located in the volume tank assembly. The other valve, AHP-V309, is located in the control console assembly. Since the two valves and the fittings that are used to connect them are identical, the following procedure covers removal, repair, and replacement for both valves. The callouts in the procedure refer to Figure 6-22 and to the illustration in Figure 7-26, which also includes an index of replacement parts.

**WARNING****Approved reentry control must be used for this procedure.**

## SS500-HK-MMO-010



**Figure 6-22. HP Gauge Isolation Valves  
(AHP-V202, AHP-V309)**

a. Remove:

- (1) For AHP-V202, bleed pressure from volume tank. For AHP-V309, remove control console panel from its case in accordance with paragraph 6.8.5.1.
- (2) Loosen tubing nuts from each end of valve (1) and remove tubing. Remove, cut, and discard valve face seal O-rings (M83248/2-010).
- (3) Using Allen wrench, remove setscrew (2) and handle pin (3) from handle (4). Remove handle from valve stem (13).

## SS500-HK-MMO-010

- (4) Position one wrench on locknut (5) and a second wrench on panel nut (6), which is located between valve body (14) and panel. Turn locknut in a counterclockwise direction and remove.
  - (5) Remove valve (1) from panel, and remove panel nut (6) from valve.
- b. Repair:
- (1) Disassemble:
    - (a) Using adjustable wrench, remove packing bolt (8) from bonnet (12).
    - (b) Drop gland (9).
    - (c) Loosen and remove union nut (7) from valve body (14).
    - (d) Remove bonnet (12) and stem (13) together; remove stem from bonnet.
    - (e) Remove packing supports (10) and packing (11) from bonnet (12).
  - (2) Reassemble:
    - (a) Place stem (13) in valve body (14).
    - (b) Drop bonnet (12) over stem (13) to rest on valve body (14). Loosely screw union nut (7) onto valve body. **Do not tighten.**
    - (c) Position new packing supports (10), new packing (11), and gland (9) over stem (13) and into bonnet (12). Press in place.
    - (d) Using adjustable wrench, screw packing bolt (8) into bonnet (12) until fully seated. Ensure stem (13) is turned fully counterclockwise.
    - (e) Tighten union nut (7) clockwise until snug.
- c. Install repaired or replacement valve as follows:
- (1) If installing replacement valve, cut and discard vendor-supplied O-rings and ensure valve has been cleaned in accordance with MIL-STD-1330 or other approved NAVSEA cleaning procedure for life support systems.
  - (2) Drop panel nut (6) over valve stem (13); secure nut to valve by rotating nut clockwise.
  - (3) Position valve stem (13) in console panel to align valve with tubes; loosely screw locknut (5) onto valve. Place wrench on packing bolt (8), and tighten locknut (5) onto valve.

## SS500-HK-MMO-010

- (4) Align handle (4) with valve stem (13) so that handle pin (3), when inserted, will contact flat surface of stem.
- (5) Insert handle pin (3) in handle (4). Using Allen wrench, screw setscrew (2) into handle to secure pin.
- (6) Using approved lubricant, lubricate two new O-rings (M83248/2-010) and install in O-ring grooves on valve (1).
- (7) Position tubing to valve and secure with tubing nuts.
- (8) Ensure locknut (5) is sufficiently tightened.
- (9) Pressurize volume tank or control console, whichever is applicable. Using NID solution prepared in accordance with paragraph 4.7.3.2, check valve and valve connections for leaks and correct as necessary. If valve leakage is detected, adjust packing in accordance with procedure b in paragraph 6.3.10.
- (10) For AHP-V309 only, reinstall control console panel in its case in accordance with paragraph 6.8.5.1.
- (11) Complete reentry control report and log.

**6.8.4.3 LP Gauge Isolation Valve (ALP-V204).** The volume tank LP gauge isolation valve (ALP-V204) is one of seven identical valves used in the LWDS MK 3 Mod 0. Other valves of this type include HP isolation valve AHP-V604 in the roof rack assembly and LP gauge isolation valves ALP-V301, -V310, -V312, -V313, and -V314 in the control console assembly. Although this valve has a working pressure of 6,000 psi, it is used for both HP and LP applications in the system. The major difference in removal and installation procedures for all seven valves involves the type of fittings that are used for connection. AHP-V604, ALP-V301, and ALP-V310 are connected by tubing nuts at each end. ALP-V204 is connected by a tubing nut at the top and by an adapter at the bottom. ALP-V312, -V313, and -V314 are connected by a tubing nut at the top and by a coupler to a tee at the bottom. Corrective maintenance for AHP-V604 is presented in paragraph 6.8.3.7 and corrective maintenance for ALP-V301, -V310, -V312, -V313, and -V314 is presented in paragraph 6.8.5.2.

Remove and repair or replace volume tank LP gauge isolation valve (ALP-V204) in accordance with the following procedure. The callouts in this procedure refer to Figure 6-18, and the part numbers for replacement parts can be found in Figure 7-27.

**WARNING**

**Approved reentry control must be used for this procedure.**

a. Remove:

- (1) Loosen tubing nut above valve (1) and remove tubing from valve.



## SS500-HK-MMO-010

- (2) Loosen upper nut on adapter, which is located below valve (1), and disconnect valve from adapter.
  - (3) Using an Allen wrench, loosen setscrew (3) and remove handle (2) from stem (6).
  - (4) Remove panel nut (4) from valve (1), and remove valve from panel. Remove, cut, and discard face seal O-rings (19).
- b. If repairing valve, repair in accordance with step b of paragraph 6.8.3.7.
- c. Install repaired or replacement valve:
- (1) New valves only: Using an Allen wrench, loosen setscrew (3) and remove handle (2) from valve stem. Remove panel nut (4) from valve. Remove, cut, and discard vendor-supplied O-rings. Ensure valve has been cleaned in accordance with MIL-STD-1330 or other approved NAVSEA cleaning procedure for life support systems.
  - (2) Using approved lubricant, lubricate replacement O-rings (19, M83248/2-010) and install one O-ring in each end fitting on body halves (10, 16).
  - (3) Position valve through panel, and secure with panel nut (4).
  - (4) Install and secure handle (2) to stem (6) by tightening setscrew (3) to stem.
  - (5) Install adapter to lower end of valve (1) and tubing to upper end of valve. Tighten nuts as required.
  - (6) Pressurize volume tank assembly. Using NID solution prepared in accordance with paragraph 4.7.3.2, check valve connections for leaks and correct as necessary.
  - (7) Complete reentry control report and log.

**6.8.4.4 Plug Valves (ALP-V205, ALP-V208, ALP-V209).** The procedure presented in this paragraph for the volume tank plug valves is similar to that for the compressor moisture separator drain valve (ALP-V402) in paragraph 6.8.2.6. Corrective maintenance for the volume tank plug valves consists of replacement of the valve or replacement of the O-rings within the valve. No procedure for O-ring replacement has been provided since replacement can be accomplished using an O-ring kit and the exploded view in Figure 7-31. Refer to Figure 7-31 for an illustration and index of replacement parts.

**WARNING****Approved reentry control must be used for this procedure.**

- a. Remove:
- (1) Depressurize volume tank as required.

## SS500-HK-MMO-010

- (2) Loosen union nut with wrench, and remove plug valve from adapter.
  - (3) Ensure all Teflon® tape is removed from adapter threads.
- b. Replace:
- (1) Ensure replacement valve has been cleaned in accordance with MIL-STD-1330 or other approved NAVSEA cleaning procedure for life support systems.
  - (2) Wrap Teflon® tape around inlet threads on adapter end of new plug valve.
  - (3) Insert taped end of new plug valve into adapter, and tighten union nut with wrench.
  - (4) Pressurize system and leak test valve using NID solution prepared in accordance with paragraph 4.7.3.2. Correct leaks as necessary.
  - (5) Complete reentry control report and log.

**6.8.4.5 Check Valve (ALP-V206).** Check valve (ALP-V206), which is located in the volume tank assembly between the primary supply pre-filter and the volume tank, is identical to check valve (ALP-V303) in the control console assembly (see paragraph 6.8.5.4). For corrective maintenance of the volume tank check valve, remove and replace the valve in accordance with the following procedure, or repair, if desired, using the procedure below for removal and installation and the illustrated parts breakdown in Figure 7-24 for repair guidance.

**WARNING**

**Approved reentry control must be used for this procedure.**

- a. Remove:
- (1) Depressurize volume tank assembly as required.
  - (2) Loosen tubing nut located between tubing and valve adapter, remove tubing from valve adapter, and bag open end of tubing.
  - (3) Remove check valve (with valve adapter still attached) from elbow, and then remove valve adapter from check valve. Bag open end of elbow.
  - (4) Remove face seal O-ring (M83248/2-111) from valve adapter, and remove the two O-rings (M83248/2-908) from straight threads of valve adapter and check valve. Cut and discard O-rings. Bag valve adapter.
  - (5) If repair is desired, use the illustrated parts breakdown in Figure 7-24 for guidance and install repaired valve in accordance with the following procedure. Otherwise, discard old check valve and replace with new check valve in accordance with the following procedure.

## SS500-HK-MMO-010

## b. Replace:

- (1) If installing new check valve, ensure valve has been cleaned in accordance with MIL-STD-1330 or other approved NAVSEA cleaning procedure for life support systems.
- (2) Remove bagging from valve adapter. Using approved lubricant, lubricate new face seal O-ring (M83248/2-111) and install in O-ring groove in valve adapter. Also lubricate new O-ring (M83248/2-908) and install on straight threads of valve adapter. Install valve adapter on new or repaired check valve.
- (3) Using approved lubricant, lubricate new O-ring (M83248/2-908) and install on straight threads of check valve.
- (4) Remove bagging from elbow. Install check valve in elbow and tighten union nut.
- (5) Remove bagging from tubing. Install tubing to valve adapter and tighten tubing nut.
- (6) Pressurize volume tank assembly. Using NID solution prepared in accordance with paragraph 4.7.3.2, check valve connections for leaks and correct as necessary.
- (7) Complete reentry control report and log.

**6.8.4.6 LP Relief Valves (ALP-V207, ALP-V211).** ALP-V207 is one of four identical LP relief valves used in the Mod 0 and Mod 1 volume tank and control console assemblies. Volume tank relief valve ALP-V207 and control console relief valve ALP-V308 are used in both the Mod 0 and Mod 1 systems. ALP-V211 and ALP-V315 are used only in the Mod 1 volume tank and control console assemblies, respectively, to provide additional relief capability for the higher pressure requirements. Corrective maintenance for the LP relief valves, which is limited to removal and replacement, is presented in the following procedure for ALP-V207 and ALP-V211, and in paragraph 6.8.5.7 for ALP-V308 and ALP-V315. Additional information on the Mod 1 valves can be found in Appendix B. An illustration and index of replacement parts for all four valves is provided in Figure 7-32.

**WARNING**

**Approved reentry control must be used for this procedure.**

## a. Remove:

- (1) Ensure volume tank is depressurized.
- (2) Unscrew relief valve from volume tank adapter (ALP-V207) or elbow (ALP-V211), and remove all traces of Teflon® tape from inside threads of adapter or elbow.
- (3) Bag open end of adapter or elbow.

## SS500-HK-MMO-010

## b. Replace:

**CAUTION**

Ensure new relief valve is tagged showing  $275 \pm 5$  psi relief pressure.

- (1) Ensure replacement valve has been cleaned in accordance with MIL-STD-1330 or other approved NAVSEA cleaning procedure for life support systems.
- (2) Beginning at third thread from end, wrap Teflon® tape onto threaded portion of new relief valve in clockwise direction. Apply a light coat of silicone grease to Teflon® tape.
- (3) Install relief valve in volume tank adapter (ALP-V207) or elbow (ALP-V211) and hand tighten. Using the appropriate tool, tighten valve one complete revolution beyond hand-tight.
- (4) Pressurize volume tank, and leak test valve using NID solution prepared in accordance with paragraph 4.7.3.2. Tighten until no leaks are detected.
- (5) Complete reentry control report and log.

**6.8.4.7 Ball Valve (ALP-V210).** Volume tank ball valve (ALP-V210) is one of four ball valves used in the LWDS MK 3 Mod 0 that are identical except for the color of the handles. The other three valves of this type are ALP-V304, ALP-V305, and ALP-V306, which are located in the control console assembly. ALP-V210 features a black handle, while the three control console valves (ALP-V304, -V305, -V306) feature a red, green, and yellow handle, respectively. Corrective maintenance for the four ball valves, which is limited to removal and replacement, is presented in the following procedure, with a reference to removal and reinstallation of the control console panel for the control console valves provided in paragraph 6.8.5.5. Refer to Figure 6-23 for parts location and to Figure 7-21 for an index of replacement parts.

**WARNING**

**Approved reentry control must be used for this procedure.**

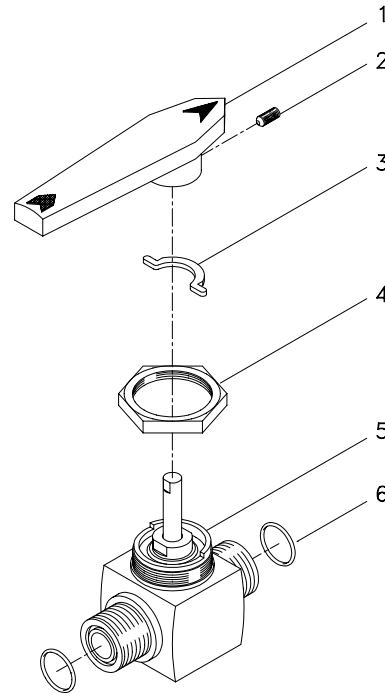
## a. Remove:

- (1) Using an Allen wrench, remove setscrew (2) from handle (1). Carefully remove handle and handle stop insert (3), which is located at base of valve stem.
- (2) Loosen tubing nuts and remove tubing from both ports in valve body (5). Remove, cut, and discard face seal O-rings (6).
- (3) Remove panel nut (4) from valve body (5).
- (4) Remove valve body (5) and spacer (if applicable) from panel.

## SS500-HK-MMO-010

## b. Replace:

- (1) Remove vendor-supplied O-rings from replacement valve; cut and discard O-rings. Ensure replacement valve has been cleaned in accordance with MIL-STD-1330 or other approved NAVSEA cleaning procedure for life support systems.
- (2) Using an Allen wrench, remove set-screw (2) from handle (1) of new valve. Carefully remove handle and handle stop insert (3), which is located at base of valve stem.
- (3) Position new valve (with spacer, if applicable) in panel and secure with panel nut (4).
- (4) Using approved lubricant, lubricate two new O-rings (6, M83248/2-111) and install in O-ring grooves in ports of valve body (5). Align tubing with ports and secure with tubing nuts.
- (5) Properly position handle stop insert (3) around base of valve stem. Install handle (1) onto valve stem and secure with setscrew (2).
- (6) Apply pressure to valve and leak test valve and valve connections using NID solution prepared in accordance with paragraph 4.7.3.2. If leaks in valve are detected, adjust packing in accordance with procedure c in paragraph 6.3.10. Correct other leaks as necessary.
- (7) Complete reentry control report and log.



**Figure 6-23. Ball Valves (ALP-V210, ALP-V304, ALP-V305, ALP-V306)**

**6.8.4.8 Mod 0 and Mod 1 HP Pressure Gauges (AHP-G211).** AHP-G211 is the JID designation for two high pressure gauges—one located in the Mod 0 volume tank assembly and the other located in the Mod 1 volume tank assembly. The only difference between the two gauges is that the Mod 0 gauge has a 0-4000 psi pressure range and the Mod 1 gauge has a 0-6000 psi pressure range. Three other gauges with a 0-4000 psi pressure range are used in the Mod 0 system—AHP-G508 in the HP air supply, AHP-G602 in the roof rack assembly, and AHP-G316 in the Mod 0 control console assembly. AHP-G316 also has a counterpart in the Mod 1 control console assembly with a pressure range of 0-6000 psi. Since these gauges are identical in every way other than the pressure ranges, corrective maintenance for the six gauges is basically the same. Refer to paragraph 6.8.3.4 for removal and replacement procedures and to Figure 7-18 for an index of replacement parts.

## SS500-HK-MMO-010

**6.8.4.9 LP Pressure Gauge (ALP-G212).** Volume tank LP pressure gauge (ALP-G212) is one of three identical gauges used in the LWDS MK 3 Mod 0. The other two gauges, ALP-G315 and ALP-G317, are located in the control console assembly. All three gauges have a pressure range of 0-500 psig and can be removed and replaced using the same basic procedure shown here. Removal and reinstallation of the control console panel is covered in paragraph 6.8.5.9 for the control console gauges. Refer to Figure 6-24 for location of the parts called out in the procedure below and to Figure 7-19 for an index of replacement parts.

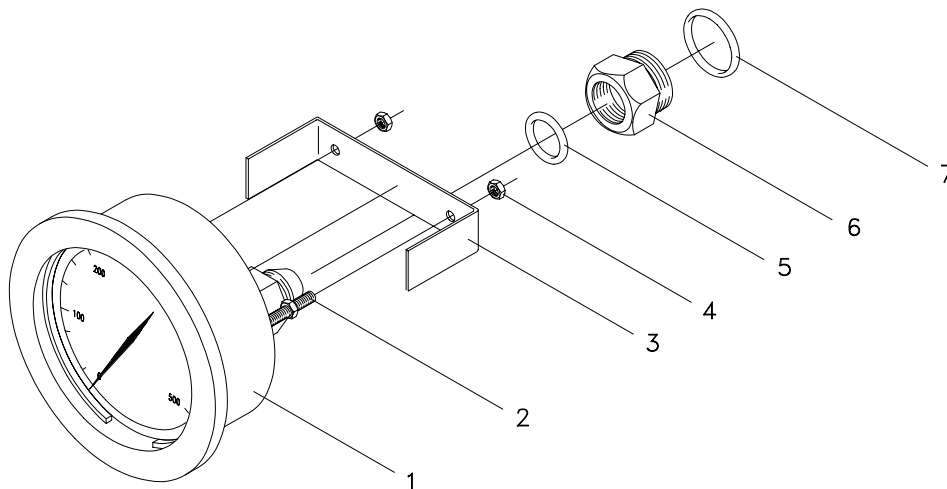
### WARNINGS

**Approved reentry control must be used for this procedure.**

**Exercise extreme care when handling pressure gauges. Failure to keep gauges, tools, and parts free of oil, grease, rust, or contaminants may cause damage or inaccurate readings. Failure to observe this warning may result in equipment failure and injury or death to personnel.**

a. Remove:

- (1) Ensure gauge is depressurized.
- (2) Loosen tubing nut and remove tubing from snubber (6). Remove face seal O-ring (7) from snubber; cut and discard O-ring.
- (3) Remove the two mounting bracket hex nuts (4) and mounting bracket (3).
- (4) Remove gauge (1) from panel.



**Figure 6-24. LP Pressure Gauges (ALP-G212, ALP-G315, ALP-G317)**

## SS500-HK-MMO-010

- (5) Remove the two mounting bracket studs (2) from rear of gauge (1).
- (6) Remove snubber (6) and O-ring (5) from gauge stem. Cut and discard O-ring.
- (7) Bag all open fittings and removed parts. If gauge is to be calibrated, tag and bag gauge in accordance with approved procedures and send to authorized calibration facility.

## b. Replace:

- (1) Ensure replacement gauge shows current calibration date and has been cleaned in accordance with MIL-STD-1330 or other approved NAVSEA cleaning procedure for life support systems.
- (2) Install mounting bracket studs (2) on replacement gauge (1).
- (3) Using approved lubricant, lubricate new O-ring (5, M83248/2-904). Install O-ring and snubber (6) on gauge stem.
- (4) Using approved lubricant, lubricate new face seal O-ring (7, M83248/2-113) and install in O-ring groove on snubber (6). If installing new snubber, discard vendor-supplied O-ring before installing O-ring (7) and ensure snubber has been cleaned in accordance with MIL-STD-1330 or other approved NAVSEA cleaning procedure for life support systems.

**WARNING**

**Ensure gauge is securely installed. Failure to tighten gauge securely may result in damage to equipment and injury or death to personnel.**

- (5) Position gauge (1) in panel, and secure mounting bracket (3) to gauge with the two hex nuts (4).
- (6) Align tubing with snubber (6) and secure with tubing nut.
- (7) Pressurize gauge. Using NID solution prepared in accordance with paragraph 4.7.3.2, check gauge connections for leaks and correct as necessary.
- (8) Complete reentry control report and log.

## SS500-HK-MMO-010

**6.8.5 Control Console Assembly.** Corrective maintenance for the control console assembly consists of repair or replacement of the following components:

- Para. 6.8.5.1—Control Console Panel . . . . . Pg 6-75
- Para. 6.8.5.2—LP Gauge Isolation Valves (ALP-V301, -V310, -V312, -V313, -V314) . . . . . Pg 6-76
- Para. 6.8.5.3—Ball Valve (ALP-V302) . . . . . Pg 6-77
- Para. 6.8.5.4—Check Valve (ALP-V303) . . . . . Pg 6-78
- Para. 6.8.5.5—Ball Valves (ALP-V304, -V305, -V306) . . . . . Pg 6-80
- Para. 6.8.5.6—HP Regulator (AHP-V307) . . . . . Pg 6-80
- Para. 6.8.5.7—LP Relief Valves (ALP-V308, -V315) . . . . . Pg 6-86
- Para. 6.8.5.8—HP Gauge Isolation Valve (AHP-V309) . . . . . Pg 6-87
- Para. 6.8.5.9—LP Pressure Gauges (ALP-G315, -G317) . . . . . Pg 6-87
- Para. 6.8.5.10—Mod 0 and Mod 1 HP Pressure Gauges (AHP-G316) . . . . . Pg 6-88
- Para. 6.8.5.11—Diver Depth Gauges (ALP-G318, -G319, -G320) . . . . . Pg 6-88

**6.8.5.1 Control Console Panel.** Before any corrective maintenance can be accomplished on the above components, the control console panel must be removed from its case. Remove and reinstall the control console panel as follows:

a. Remove:

- (1) Relieve pressure from system. Remove all hoses from rear panel.
- (2) Remove cover from control console assembly case.
- (3) Loosen front panel screws. Remove front panel retaining ring and seal.
- (4) Open rear panel and loosen rear panel screws.
- (5) Carefully remove panel assembly from case.
- (6) Perform required maintenance.

b. Reinstall:

- (1) Ensure all gaskets are in place and serviceable. Replace as necessary.
- (2) Carefully place panel assembly in case.
- (3) Tighten rear panel screws in rear panel.
- (4) Install front panel retaining ring with seal and secure all front panel screws.



## SS500-HK-MMO-010

**6.8.5.2 LP Gauge Isolation Valves (ALP-V301, ALP-V310, ALP-V312, ALP-V313, ALP-V314).**

The five control console LP gauge isolation valves are identical to two other valves used in the LWDS MK 3 Mod 0. Other valves of this type include HP isolation valve AHP-V604 in the roof rack assembly and LP gauge isolation valve ALP-V204 in the volume tank assembly. Although this valve has a working pressure of 6,000 psi, it is used for both HP and LP applications in the system. The major difference in removal and installation procedures for all seven valves involves the type of fittings that are used for connection. AHP-V604, ALP-V301, and ALP-V310 are connected by tubing nuts at each end. ALP-V204 is connected by a tubing nut at the top and by an adapter at the bottom. ALP-V312, -V313, and -V314 are connected by a tubing nut at the top and by a coupler to a tee at the bottom. Corrective maintenance for ALP-V204 is presented in paragraph 6.8.4.3 and corrective maintenance for AHP-V604 is presented in paragraph 6.8.3.7, which contains repair procedures referenced in this paragraph.

Remove and repair or replace control console LP gauge isolation valves (ALP-V301, -V310, -V312, -V313, and -V314) in accordance with the following procedure. The callouts in the procedure refer to Figure 6-18, and an index of replacement parts can be found in Figure 7-27.

**WARNING**

**Approved reentry control must be used for this procedure.**

- a. Remove:
  - (1) Remove control console panel from its case in accordance with paragraph 6.8.5.1.
  - (2) For ALP-V301 and ALP-V310 only: Loosen tubing nuts and remove tubing from both ends of valve (1).
  - (3) For ALP-V312, -V313, and -V314 only: Loosen tubing nut above valve (1) and remove tubing from valve. Loosen upper nut on coupler, which is located between valve and tee, and disconnect valve from coupler.
  - (4) Using an Allen wrench, loosen setscrew (3) and remove handle (2) from stem (6).
  - (5) Remove panel nut (4) from valve (1), and remove valve from panel. Remove, cut, and discard face seal O-rings (19).
- b. If repairing valve, repair in accordance with step b of paragraph 6.8.3.7.
- c. Install repaired or replacement valve:
  - (1) New valves only: Using an Allen wrench, loosen setscrew (3) and remove handle (2) from valve stem. Remove panel nut (4) from valve. Remove, cut, and discard vendor-supplied O-rings. Ensure valve has been cleaned in accordance with MIL-STD-1330 or other approved NAVSEA cleaning procedure for life support systems.

## SS500-HK-MMO-010

- (2) Using approved lubricant, lubricate replacement O-rings (19, M83248/2-010) and install one O-ring in each end fitting on body halves (10, 16).
- (3) Position valve through panel, and secure with panel nut (4).
- (4) Install and secure handle (2) to stem (6) by tightening setscrew (3) to stem.
- (5) For ALP-V301 and ALP-V310 only: Install tubing to both ends of valve (1) and secure with tubing nuts.
- (6) For ALP-V312, -V313, and -V314 only: Install coupler to lower end of valve (1) and tubing to upper end of valve. Tighten nuts as required.
- (7) Pressurize control console assembly. Using NID solution prepared in accordance with paragraph 4.7.3.2, check connections for leaks and correct as necessary.
- (8) Reinstall control console panel in its case in accordance with paragraph 6.8.5.1.
- (9) Complete reentry control report and log.

**6.8.5.3 Ball Valve (ALP-V302).** Ball valve (ALP-V302) is also known as the supply selector valve in the control console assembly. Although ALP-V302 is similar to four other ball valves in the system (ALP-V210, -V304, -V305, and -V306), corrective maintenance is presented separately since ALP-V302 does not feature a handle stop insert and has three ports instead of two. Corrective maintenance for ALP-V302 is limited to removal and replacement in accordance with the following procedure. Refer to Figure 6-25 for parts location and to Figure 7-22 for an index of replacement parts.

**WARNING**

**Approved reentry control must be used for this procedure.**

- a. Remove:
  - (1) Remove control console panel from its case in accordance with paragraph 6.8.5.1.
  - (2) Using an Allen wrench, remove setscrew (3) from handle (2). Carefully remove handle from valve body (5).
  - (3) Loosen union nut and the two tubing nuts and remove adapter and tubing from valve body (5). Remove, cut, and discard face seal O-rings (6).
  - (4) Remove panel nut (4) from valve body (5).
  - (5) Remove valve body (5) from panel.

## SS500-HK-MMO-010

## b. Replace:

- (1) Remove vendor-supplied O-rings from replacement valve; cut and discard O-rings. Ensure replacement valve has been cleaned in accordance with MIL-STD-1330 or other approved NAVSEA cleaning procedure for life support systems.
- (2) Using an Allen wrench, remove set-screw (3) from handle (2) of new ball valve (1). Carefully remove handle from valve body (5).
- (3) Position new valve in panel and secure with panel nut (4).
- (4) Using approved lubricant, lubricate three new O-rings (6, M83248/2-111) and install in O-ring grooves of all ports in valve body (5). Align tubing and adapter with valve ports; tighten tubing and union nuts to valve body (5).

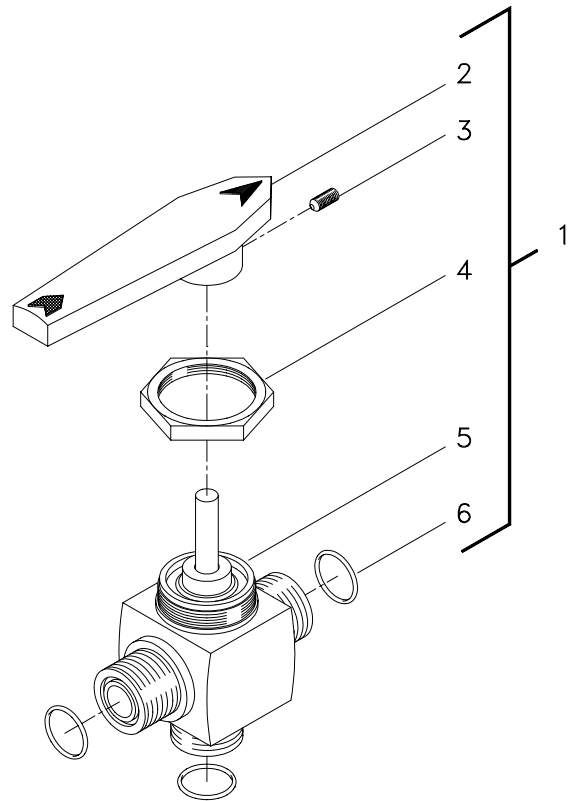


Figure 6-25. Ball Valve (ALP-V302)

- (5) Install handle (2) onto valve stem and secure with setscrew (3).
- (6) Apply pressure to valve and leak test valve and valve connections using NID solution prepared in accordance with paragraph 4.7.3.2. If valve leaks are detected, adjust packing in accordance with procedure c in paragraph 6.3.10. Correct other leaks as necessary.
- (7) Reinstall control console panel in its case in accordance with paragraph 6.8.5.1.
- (8) Complete reentry control report and log.

**6.8.5.4 Check Valve (ALP-V303).** Check valve (ALP-V303), which is located in the control console assembly between the primary supply inlet and the supply selector valve (ALP-V302), is identical to check valve (ALP-V206) in the volume tank assembly (see paragraph 6.8.4.5) For corrective maintenance of the control console check valve, remove and replace the valve in accordance with the following procedure, or repair, if desired, using the procedure below for removal and installation and the illustrated parts breakdown in Figure 7-24 for repair guidance.

**WARNING**

**Approved reentry control must be used for this procedure.**

## SS500-HK-MMO-010

## a. Remove:

- (1) Remove control console panel from its case in accordance with paragraph 6.8.5.1.
- (2) Loosen upper and lower tubing nuts located between tubing and the two tee adapters, and remove tubing from adapters. Bag open ends of tubing.
- (3) At supply selector valve (ALP-V302), remove valve adapter, check valve, and tee as a unit from ALP-V302. Remove face seal O-ring (M83248/2-111) from open port in ALP-V302. Cut and discard O-ring and bag open port.
- (4) Remove valve adapter from check valve, and then remove check valve from tee.
- (5) Remove the two straight thread O-rings (M83248/2-908) from valve adapter and check valve. Remove the two face seal O-rings (M83248/2-111) from the two tee adapters. Cut and discard O-rings. Bag valve adapter and tee.
- (6) If repair is desired, use the illustrated parts breakdown in Figure 7-24 for guidance and install repaired valve in accordance with the following procedure. Otherwise, discard old check valve and replace with new check valve in accordance with the following procedure.

## b. Replace:

- (1) If installing new check valve, ensure valve has been cleaned in accordance with MIL-STD-1330 or other approved NAVSEA cleaning procedure for life support systems.
- (2) Using approved lubricant, lubricate new O-ring (M83248/2-908) and install on straight threads of new or repaired check valve. Remove bagging from tee and install check valve in tee.
- (3) Remove bagging from valve adapter. Using approved lubricant, lubricate new O-ring (M83248/2-908) and install on straight threads of valve adapter. Install valve adapter into check valve.
- (4) Remove bagging from supply selector valve (ALP-V302). Using approved lubricant, lubricate new face seal O-ring (M83248/2-111) and install in O-ring groove in supply selector valve.
- (5) Using approved lubricant, lubricate two new face seal O-rings (M83248/2-111) and install in O-ring grooves in the two tee adapters.
- (6) Install valve adapter (with attached valve and tee) onto ALP-V302.
- (7) Remove bagging from tubing, and install tubing to the two tee adapters. Tighten tubing nuts.
- (8) Pressurize control console assembly. Using NID solution prepared in accordance with paragraph 4.7.3.2, check connections for leaks and correct as necessary.

## SS500-HK-MMO-010

- (9) Reinstall control console panel in its case in accordance with paragraph 6.8.5.1.
- (10) Complete reentry control report and log.

**6.8.5.5 Ball Valves (ALP-V304, ALP-V305, ALP-V306).** Since the control console ball valves (ALP-V304, ALP-V305, and ALP-V306) are identical to the ball valve used in the volume tank assembly (ALP-V210), the same basic procedure presented in paragraph 6.8.4.7 can be used for all four valves with the exception of the removal and reinstallation of the control console panel as shown below for the control console ball valves.

- a. Remove control console panel from its case in accordance with paragraph 6.8.5.1.
- b. Remove and replace damaged/defective valve in accordance with corrective maintenance procedure in paragraph 6.8.4.7.
- c. Reinstall control console panel in its case in accordance with paragraph 6.8.5.1.

**6.8.5.6 HP Regulator (AHP-V307).** There are two identical HP regulators in the LWDS MK 3 Mod 0—AHP-V307 in the control console assembly and AHP-V201 in the volume tank assembly. To allow for differences in removal and replacement, corrective maintenance for AHP-V307 is presented here and corrective maintenance for AHP-V201 is provided in paragraph 6.8.4.1. Since two versions of the regulator—one made by Circle Seal and the other by Tescom—are approved for use in the LWDS MK 3 Mod 0, corrective maintenance has been further divided in each paragraph and the resulting procedures are identified according to the manufacturer: Procedure A for the Circle Seal regulator and Procedure B for the Tescom regulator. Corrective maintenance of the Circle Seal regulator is limited to removal and replacement at the organizational level; therefore, any Circle Seal regulator in need of repair should be sent to an authorized repair facility for overhaul. Tescom regulators may be removed and replaced or repaired locally if the capability for such repair exists at the organizational level.

#### PROCEDURE A: CIRCLE SEAL REGULATOR

Remove and replace damaged/defective Circle Seal HP regulator (AHP-V307) in accordance with the following procedure. Unless otherwise noted, refer to Figure 6-19 for parts location and to Figure 7-33 for an index of replacement parts. If repair is desired, send regulator to an authorized repair facility for overhaul.

#### WARNING

**Approved reentry control must be used for this procedure.**

- a. Remove:
  - (1) Remove control console panel from its case in accordance with paragraph 6.8.5.1.
  - (2) Using 3/32-inch Allen wrench, remove cap retaining screw (1) from center of regulator handle (4) on control panel.

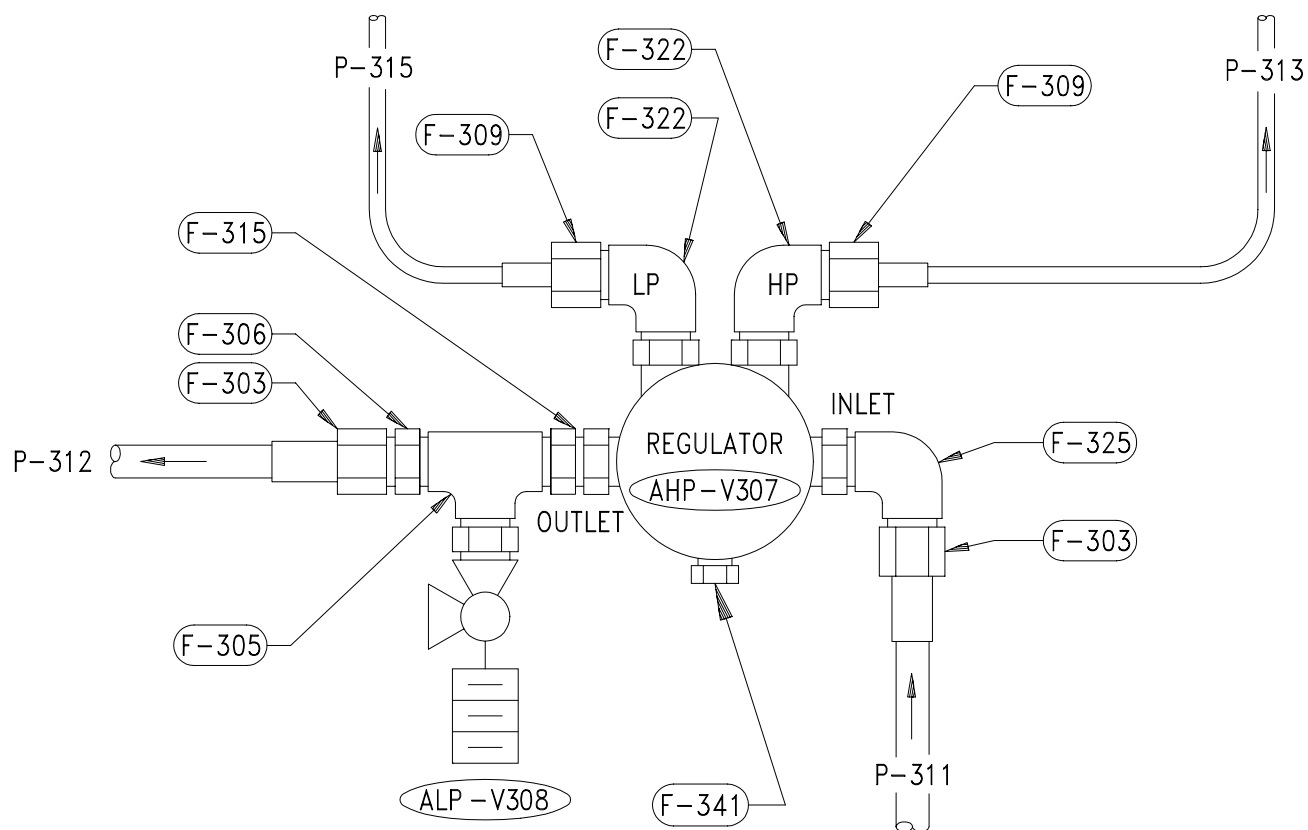
## SS500-HK-MMO-010

- (3) Using sturdy tool with flat tip, pry data plate (2) from handle (4).
- (4) Using 1/8-inch Allen wrench, remove the three handle retaining screws (3) from handle (4). Remove handle.
- (5) Remove rubber sleeve (5) from housing (7).

**NOTE**

Refer to Figure 6-26 for the location of parts called out in Steps (6) thru (9) and (11) thru (14). Figure 6-26 reflects a portion of the control console assembly schematic found on JID 6314821, sheet 5.

- (6) **AT HP GAUGE PORT ELBOW (F-322):** Loosen tubing nut (F-309) and remove tubing (P-313) from elbow (F-322). Bag open end of tubing.
- (7) **AT LP GAUGE PORT ELBOW (F-322):** Loosen tubing nut (F-309) and remove tubing (P-315) from elbow (F-322). Bag open end of tubing.
- (8) **AT INLET PORT ELBOW (F-325):** Loosen tubing nut (F-303) and remove tubing (P-311) from elbow (F-325). Bag open end of tubing.



**Figure 6-26. Location of Parts Attached to Regulator (AHP-V307)**

## SS500-HK-MMO-010

- (9) **AT OUTLET PORT TEE (F-305):** Loosen tubing nut (F-303) and remove tubing (P-312) from tee adapter (F-306). Bag open end of tubing.
  - (10) While maintaining a firm hold on the regulator, remove panel nut (Figure 6-19, 6) from housing (7). Carefully remove regulator with fittings still attached.
  - (11) **AT HP AND LP GAUGE PORTS:** Remove the two elbows (F-322) from regulator HP and LP gauge ports. Remove O-ring (M83248/2-904) and face seal O-ring (M83248/2-010) from each elbow; cut and discard O-rings. Bag elbows.
  - (12) **AT INLET PORT:** Remove elbow (F-325) from regulator inlet port. Remove, cut, and discard O-ring (M83248/2-908) and face seal O-ring (M83248/2-111). Bag elbow.
  - (13) **AT OUTLET PORT:** Loosen nut on regulator end of positionable union (F-315) and remove tee (F-305) (with fittings attached) from regulator outlet port. Remove O-ring (M83248/2-908) from positionable union (F-315) and face seal O-ring (M83248/2-111) from tee adapter (F-306); cut and discard O-rings. Bag open ends of tee.
  - (14) **AT VENT PORT:** Remove bleeder plug (F-341) from regulator vent port. Remove, cut, and discard plug O-ring (M83248/2-904). Bag bleeder plug.
  - (15) Tag and bag removed regulator in accordance with approved procedures and send to an authorized repair facility for overhaul.
- b. Install replacement regulator as follows:
- (1) Ensure replacement regulator has been cleaned in accordance with MIL-STD-1330 or other approved NAVSEA cleaning procedure for life support systems.

**NOTE**

Refer to Figure 6-26 for location of components called out in Steps (2) thru (7) and (9) thru (12).

- (2) **AT VENT PORT:** Remove bagging from bleeder plug (F-341). Using approved lubricant, lubricate one new O-ring (M83248/2-904) and install on bleeder plug (F-341). Install bleeder plug in regulator vent port.
- (3) **AT OUTLET PORT:** Remove bagging from tee (F-305). Using approved lubricant, lubricate new O-ring (M83248/2-908) and install on positionable union (F-315). Using approved lubricant, lubricate new face seal O-ring (M83248/2-111) and install in O-ring groove on tee adapter (F-306). Install positionable union end of tee (F-305) in regulator outlet port and tighten union nut.

## SS500-HK-MMO-010

- (4) **AT INLET PORT:** Remove bagging from elbow (F-325). Using approved lubricant, lubricate one new O-ring (M83248/2-908) and install on straight threads of elbow (F-325). Install elbow in regulator inlet port.
- (5) Using approved lubricant, lubricate one new face seal O-ring (M83248/2-111) and install in O-ring groove of elbow (F-325).
- (6) **AT HP AND LP GAUGE PORTS:** Remove bagging from the two elbows (F-322). Using approved lubricant, lubricate two new O-rings (M83248/2-904) and install on straight threads of elbows. Install elbows in regulator HP and LP gauge ports.
- (7) Using approved lubricant, lubricate two new face seal O-rings (M83248/2-010) and install in O-ring grooves on LP and HP gauge port elbows (F-322).
- (8) Insert regulator through rear opening in panel, then reach around panel and install panel nut (Figure 6-19, 6) on housing (7). To maintain correct positioning of ports, hold regulator securely while tightening panel nut.
- (9) **AT OUTLET PORT TEE (F-305):** Remove bagging from tubing (P-312). Install tubing to tee adapter (F-306) and tighten tubing nut (F-303).
- (10) **AT INLET PORT ELBOW (F-325):** Remove bagging from tubing (P-311). Install tubing to elbow (F-325) and tighten tubing nut (F-303).
- (11) **AT LP GAUGE PORT ELBOW (F-322):** Remove bagging from tubing (P-315). Install tubing to LP gauge port elbow (F-322) and tighten tubing nut (F-309).
- (12) **AT HP GAUGE PORT ELBOW (F-322):** Remove bagging from tubing (P-313). Install tubing to HP gauge port elbow (F-322) and tighten tubing nut (F-309).
- (13) At front of panel, install rubber sleeve (Figure 6-19, 5) on housing (7).
- (14) Install handle (4) on housing (7). Using 1/8-inch Allen wrench, secure handle with the three handle retaining screws (3).
- (15) Insert data plate (2) in handle (4). Using 3/32-inch Allen wrench, secure data plate with cap retaining screw (1).
- (16) Apply pressure to control console assembly from primary HP air source. Operate regulator through turning arc (not to exceed 220 psi) and leak test using NID solution prepared in accordance with paragraph 4.7.3.2. Correct leaks as necessary.
- (17) Reinstall control console panel in its case in accordance with paragraph 6.8.5.1.
- (18) Complete reentry control report and log.



## SS500-HK-MMO-010

**PROCEDURE B: TESCOM REGULATOR**

Corrective maintenance for Tescom HP regulator (AHP-V307) includes removal and replacement, or repair if the capability for such repair exists at the organizational level. For removal and replacement, follow the procedure provided below, and unless otherwise noted, refer to Figure 6-21 for parts location and to Figure 7-34 for an index of replacement parts. For repair guidance, refer to the manufacturer's technical documentation and to the illustrated parts breakdown in Figure 7-34.

**WARNING**

**Approved reentry control must be used for this procedure.**

## a. Remove:

- (1) Remove control console panel from its case in accordance with paragraph 6.8.5.1.
- (2) Using flat-tip screwdriver, pry hole plug (1) from hand knob (3).
- (3) Using external snap-ring pliers, remove retaining ring (2) from adjusting screw assembly (not shown). Remove hand knob (3).

**NOTE**

Refer to Figure 6-26 for the location of parts called out in Steps (4) thru (7) and (9) thru (12). Figure 6-26 reflects a portion of the control console assembly schematic found on sheet 5 of JID 6314821.

- (4) **AT HP GAUGE PORT ELBOW (F-322):** Loosen tubing nut (F-309) and remove tubing (P-313) from elbow (F-322). Bag open end of tubing.
- (5) **AT LP GAUGE PORT ELBOW (F-322):** Loosen tubing nut (F-309) and remove tubing (P-315) from elbow (F-322). Bag open end of tubing.
- (6) **AT INLET PORT ELBOW (F-325):** Loosen tubing nut (F-303) and remove tubing (P-311) from elbow (F-325). Bag open end of tubing.
- (7) **AT OUTLET PORT TEE (F-305):** Loosen tubing nut (F-303) and remove tubing (P-312) from tee adapter (F-306). Bag open end of tubing.
- (8) While maintaining a firm hold on the regulator, remove panel nut (Figure 6-21, 4) from housing (5). Carefully remove regulator with fittings still attached.
- (9) **AT HP AND LP GAUGE PORTS:** Remove the two elbows (F-322) from regulator HP and LP gauge ports. Remove O-ring (M83248/2-904) and face seal O-ring (M83248/2-010) from each elbow; cut and discard O-rings. Bag elbows.

## SS500-HK-MMO-010

- (10) **AT INLET PORT:** Remove elbow (F-325) from regulator inlet port. Remove, cut, and discard O-ring (M83248/2-908) and face seal O-ring (M83248/2-111). Bag elbow.
- (11) **AT OUTLET PORT:** Loosen nut on regulator end of positionable union (F-315) and remove tee (F-305) (with fittings attached) from regulator outlet port. Remove O-ring (M83248/2-908) from positionable union (F-315) and face seal O-ring (M83248/2-111) from tee adapter (F-306); cut and discard O-rings. Bag open ends of tee.
- (12) **AT VENT PORT:** Remove bleeder plug (F-341) from regulator vent port. Remove, cut, and discard plug O-ring (M83248/2-904). Bag bleeder plug.
- (13) Tag and bag removed regulator in accordance with approved procedures and send to an authorized repair facility for overhaul, or repair locally. Local repair is authorized if the capability for such repair exists at the organizational level. For repair guidance, refer to the manufacturer's technical documentation and to the illustrated parts breakdown in Figure 7-34.

b. Install replacement regulator as follows:

- (1) Ensure replacement regulator has been cleaned in accordance with MIL-STD-1330 or other approved NAVSEA cleaning procedure for life support systems.

**NOTE**

Refer to Figure 6-26 for location of components called out in Steps (2) thru (7) and (9) thru (12).

- (2) **AT VENT PORT:** Remove bagging from bleeder plug (F-341). Using approved lubricant, lubricate one new O-ring (M83248/2-904) and install on bleeder plug (F-341). Install bleeder plug in regulator vent port.
- (3) **AT OUTLET PORT:** Remove bagging from tee (F-305). Using approved lubricant, lubricate one new O-ring (M83248/2-908) and install on positionable union (F-315). Using approved lubricant, lubricate new face seal O-ring (M83248/2-111) and install in O-ring groove on tee adapter (F-306). Install positionable union end of tee (F-305) in regulator outlet port and tighten union nut.
- (4) **AT INLET PORT:** Remove bagging from elbow (F-325). Using approved lubricant, lubricate one new O-ring (M83248/2-908) and install on straight threads of elbow (F-325). Install elbow in regulator inlet port.
- (5) Using approved lubricant, lubricate one new face seal O-ring (M83248/2-111) and install in O-ring groove of elbow (F-325).

## SS500-HK-MMO-010

- (6) **AT HP AND LP GAUGE PORTS:** Remove bagging from the two elbows (F-322). Using approved lubricant, lubricate two new O-rings (M83248/2-904) and install on straight threads of elbows. Install elbows in regulator HP and LP gauge ports.
- (7) Using approved lubricant, lubricate two new face seal O-rings (M83248/2-010) and install in O-ring grooves on LP and HP gauge port elbows (F-322).
- (8) Insert regulator through rear opening in panel, then reach around panel and install panel nut (Figure 6-21, 4) on housing (5). To maintain correct positioning of ports, hold regulator securely while tightening panel nut.
- (9) **AT OUTLET PORT TEE (F-305):** Remove bagging from tubing (P-312). Install tubing to tee adapter (F-306) and tighten tubing nut (F-303).
- (10) **AT INLET PORT ELBOW (F-325):** Remove bagging from tubing (P-311). Install tubing to elbow (F-325) and tighten tubing nut (F-303).
- (11) **AT LP GAUGE PORT ELBOW (F-322):** Remove bagging from tubing (P-315). Install tubing to LP gauge port elbow (F-322) and tighten tubing nut (F-309).
- (12) **AT HP GAUGE PORT ELBOW (F-322):** Remove bagging from tubing (P-313). Install tubing to HP gauge port elbow (F-322) and tighten tubing nut (F-309).
- (13) At front of panel, install hand knob (Figure 6-21, 3) on housing (5). Insert retaining ring (2) into adjusting screw assembly (not shown).
- (14) Install hole plug (1) into hand knob (3).
- (15) Apply pressure to control console assembly from primary HP air source. Operate regulator through turning arc (not to exceed 220 psi) and leak test using NID solution prepared in accordance with paragraph 4.7.3.2. Correct leaks as necessary.
- (16) Reinstall control console panel in its case in accordance with paragraph 6.8.5.1.
- (17) Complete reentry control report and log.

**6.8.5.7 LP Relief Valves (ALP-V308, ALP-V315).** ALP-V308 is one of four identical LP relief valves used in the Mod 0 and Mod 1 volume tank and control console assemblies. Volume tank relief valve ALP-V207 and control console relief valve ALP-V308 are used in both the Mod 0 and Mod 1 systems. ALP-V211 and ALP-V315 are used only in the Mod 1 volume tank and control console assemblies, respectively, to provide additional relief capability for the higher pressure requirements. Corrective maintenance for the LP relief valves, which is limited to removal and replacement, is presented in the following procedure for ALP-V308 and ALP-V315, and in paragraph 6.8.4.6 for ALP-V207 and ALP-V211. Additional information on the Mod 1 valves can be found in Appendix B. An illustration and index of replacement parts for all four valves is provided in Figure 7-32.

## SS500-HK-MMO-010

**WARNING**

**Approved reentry control must be used for this procedure.**

## a. Remove:

- (1) Remove control console panel from its case in accordance with paragraph 6.8.5.1.
- (2) For ALP-V308: Unscrew relief valve from tee-to-valve adapter (Mod 0) or cross-to-valve adapter (Mod 1). For ALP-V315: Unscrew relief valve from cross-to-valve elbow fitting. Remove all traces of Teflon® tape from inside threads of adapter or elbow.
- (3) Bag open end of adapter or elbow.

## b. Replace:

**CAUTION**

Ensure new relief valve is tagged showing  $275 \pm 5$  psi relief pressure.

- (1) Ensure replacement valve has been cleaned in accordance with MIL-STD-1330 or other approved NAVSEA cleaning procedure for life support systems.
- (2) Beginning at third thread from end, wrap Teflon® tape onto threaded portion of new relief valve in clockwise direction. Apply a light coat of silicone grease to Teflon® tape.
- (3) Install relief valve in adapter (ALP-V308) or elbow (ALP-V315) and hand tighten. Using the appropriate tool, tighten valve one complete revolution beyond hand-tight.
- (4) Pressurize control console assembly, and leak test valve using NID solution prepared in accordance with paragraph 4.7.3.2. Tighten until no leaks are detected.
- (5) Reinstall control console panel in its case in accordance with paragraph 6.8.5.1.
- (6) Complete reentry control report and log.

**6.8.5.8 HP Gauge Isolation Valve (AHP-V309).** Since control console and volume tank HP gauge isolation valves AHP-V309 and AHP-V202, respectively, and the fittings that are used to connect them are identical, corrective maintenance for the two valves is contained in a single procedure. Refer to paragraph 6.8.4.2 for corrective maintenance of AHP-V202 and AHP-V309.

**6.8.5.9 LP Pressure Gauges (ALP-G315, ALP-G317).** Control console LP pressure gauges (ALP-G315 and ALP-G317) are identical to ALP-G212, which is located in the volume tank

## SS500-HK-MMO-010

assembly. All three gauges have a pressure range of 0-500 psig and can be removed and replaced using the same basic procedure with the exception of removal and reinstallation of the control console panel, which is referenced below. Refer to Figure 7-19 for an illustration and index of replacement parts.

- a. Remove control console panel from its case in accordance with paragraph 6.8.5.1.
- b. Remove and replace damaged/defective gauge in accordance with the corrective maintenance procedure shown in paragraph 6.8.4.9.
- c. Reinstall control console panel in its case in accordance with paragraph 6.8.5.1.

**6.8.5.10 Mod 0 and Mod 1 HP Pressure Gauges (AHP-G316).** AHP-G316 is the JID designation for two high pressure gauges—one located in the Mod 0 control console assembly and the other located in the Mod 1 control console assembly. The only difference between the two gauges is that the Mod 0 gauge has a 0-4000 psi pressure range and the Mod 1 gauge has a 0-6000 psi pressure range. Three other gauges with a 0-4000 psi pressure range are used in the Mod 0 system—AHP-G508 in the HP air supply, AHP-G602 in the roof rack assembly, and AHP-G211 in the Mod 0 volume tank assembly. AHP-G211 also has a counterpart in the Mod 1 volume tank assembly with a pressure range of 0-6000 psi. Since these gauges are identical in every way other than the pressure ranges, corrective maintenance for the six gauges is basically the same. Refer to paragraph 6.8.3.4 for removal and replacement procedures and to Figure 7-18 for an index of replacement parts.

**6.8.5.11 Diver Depth Gauges (ALP-G318, ALP-G319, ALP-G320).** The diver depth gauges are the only three depth gauges used in the LWDS MK 3 Mod 0. ALP-G318 is located on the panel for the red diver, ALP-G319 on the panel for the green diver, and ALP-G320 on the panel for the yellow diver. The back of each gauge contains a blow-out plug, which serves as a safety device in the event of overpressurization. Corrective maintenance for the diver depth gauges is limited to removal and replacement in accordance with the following procedure. Refer to Figure 6-27 for parts location and to Figure 7-17 for an index of replacement parts.

**WARNING**

**Approved reentry control must be used for this procedure.**

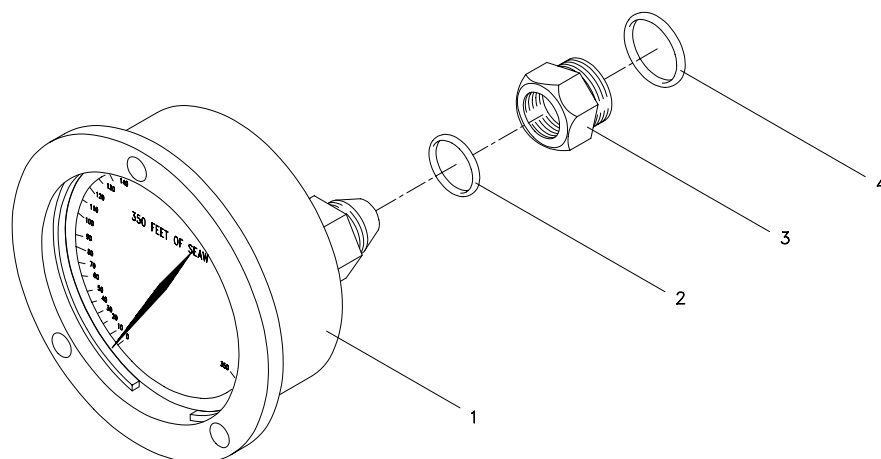
- a. Remove:
  - (1) Remove control console panel from its case in accordance with paragraph 6.8.5.1.

**NOTE**

When loosening or tightening tubing pieces and fittings, hold both sides of fittings.

- (2) Loosen tubing nut and remove tubing from snubber (3). Remove face seal O-ring (4) from snubber; cut and discard O-ring.

## SS500-HK-MMO-010



**Figure 6-27. Diver Depth Gauges (ALP-G318, ALP-G319, ALP-G320)**

- (3) Remove gauge (1) from panel.
  - (4) Remove snubber (3) and O-ring (2) from gauge stem. Cut and discard O-ring.
  - (5) Bag all open fittings and removed parts. If gauge is to be calibrated, tag and bag gauge in accordance with approved procedures and send to authorized calibration facility.
- b. Replace:
- (1) Ensure replacement gauge shows current calibration date and has been cleaned in accordance with MIL-STD-1330 or other approved NAVSEA cleaning procedure for life support systems.
  - (2) Using approved lubricant, lubricate new face seal O-ring (4, M83248/2-113) and install in O-ring groove on snubber (3). If installing new snubber, modify snubber by removing sintered element and retaining ring in accordance with LWDS drawing 6314404. Also, remove and discard vendor-supplied O-ring before installing O-ring (4), and ensure snubber has been cleaned in accordance with MIL-STD-1330 or other approved NAVSEA cleaning procedure for life support systems.
  - (3) Using approved lubricant, lubricate new O-ring (2, M83248/2-904). Install O-ring (2) and modified snubber (3) on gauge stem.

SS500-HK-MMO-010

**WARNING**

**Ensure gauge is securely installed. Failure to tighten gauge securely may result in damage to equipment and injury or death to personnel.**

- (4) Install replacement gauge (1) in panel. Align tubing with snubber (3) and secure with tubing nut.
- (5) Pressurize control console assembly. Using NID solution prepared in accordance with paragraph 4.7.3.2, check connections for leaks and correct as necessary.
- (6) Reinstall control console panel in its case in accordance with paragraph 6.8.5.1.
- (7) Complete reentry control report and log.

## SS500-HK-MMO-010

**CHAPTER 7****PARTS LISTS****7.1 INTRODUCTION**

This chapter contains replacement parts lists and parts location illustrations to assist the maintenance technician in performing organizational-level maintenance on the Lightweight Dive System (LWDS) MK 3 Mod 0. Table 7-1 provides an index to the parts lists presented in this chapter along with page number references for the corresponding corrective maintenance procedures in Chapter 6. The individual parts lists contain item numbers corresponding to the callouts in the accompanying illustrations, along with item descriptions, Commercial and Government Entity (CAGE) codes for manufacturer identification, National Stock Numbers (NSNs), identifying part numbers, and quantities required per assembly. Table 7-2, located at the end of this chapter, identifies the manufacturers and suppliers by their associated CAGE codes and provides contact information for ordering replacement parts.

**Table 7-1. LWDS MK 3 Mod 0 Replacement Parts Index**

<b>Nomenclature</b>	<b>Valve</b>	<b>Gauge</b>	<b>Type</b>	<b>Used On</b>	<b>Page References</b>	
Belt, Drive				Air Compressor	7-6	6-26
Covers, Cylinder Head				Diesel Engine	7-3	6-16
Filter, Air				Air Compressor	7-7	
Filter, Air, HP Supply				Volume Tank *	7-11	
Filter Element				Volume Tank	7-11	
Filter Element, Air				Diesel Engine	7-4	
Filter Element, Snorkel				Snorkel Assembly	7-7	
Filter, Fuel				Diesel Engine	7-4	
Flasks, HP Air / Composite				HP Air Supply	7-32	6-38
Gauge, Diver Depth		G318	ALP	Control Console	7-12	6-88
		G319	ALP	Control Console	7-12	6-88
		G320	ALP	Control Console	7-12	6-88
Gauge, Pressure, HP		G211	AHP	Volume Tank *	7-12	6-72
		G316	AHP	Control Console *	7-12	6-88
		G508	AHP	HP Air Supply	7-12	6-47
		G602	AHP	Roof Rack Assy	7-12	6-47
Gauge, Pressure, LP		G212	ALP	Volume Tank	7-13	6-73
		G315	ALP	Control Console	7-13	6-87
		G317	ALP	Control Console	7-13	6-87
		G406	ALP	Air Compressor	7-13	6-36

\* Found in both Mod 0 and Mod 1 configurations



## SS500-HK-MMO-010

Table 7-1. LWDS MK 3 Mod 0 Replacement Parts Index—Continued

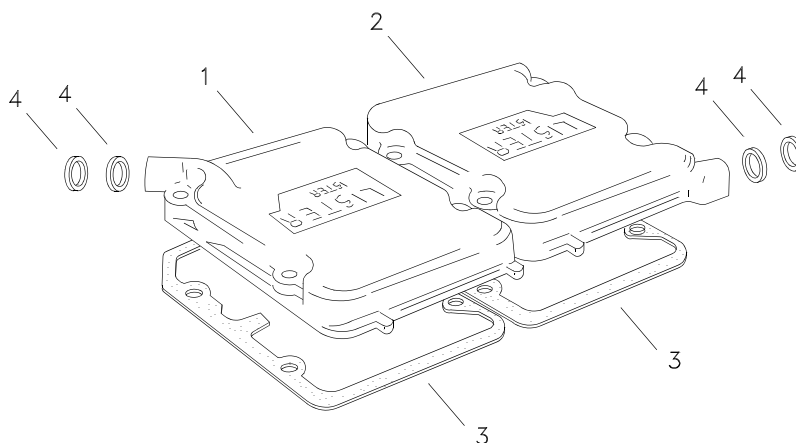
Nomenclature	Valve	Gauge	Type	Used On	Page References	
Injector, Fuel				Diesel Engine	7-5	6-21
Muffler, Exhaust				Diesel Engine	7-6	6-23
Nipple, Hose				HP Hose Assy	7-10	6-46
O-rings, Inspection Port Plug				Volume Tank	7-32	
Panel, Control Console				Control Console		6-75
Pump, Fuel				Diesel Engine	7-5	6-19
Separator, Moisture				Air Compressor	7-8	
Softseat				HP Hose Assy	7-10	6-46
Valve, Ball	V210		ALP	Volume Tank	7-14	6-71
	V302		ALP	Control Console	7-15	6-77
	V304		ALP	Control Console	7-14	6-80
	V305		ALP	Control Console	7-14	6-80
	V306		ALP	Control Console	7-14	6-80
	V401		ALP	Air Compressor	7-16	6-29
	V405		ALP	Air Compressor	7-16	6-29
Valve, Check	V206		ALP	Volume Tank	7-17	6-69
	V303		ALP	Control Console	7-17	6-78
Valve, Flask Shutoff	V505		AHP	HP Air Supply	7-18	6-46
	V506		AHP	HP Air Supply	7-18	6-46
	V507		AHP	HP Air Supply	7-18	6-46
Valve, Gauge Isolation, HP	V202		AHP	Volume Tank	7-19	6-64
	V309		AHP	Control Console	7-19	6-87
Valve, Gauge Isolation, LP	V204		ALP	Volume Tank	7-20	6-67
	V301		ALP	Control Console	7-20	6-76
	V310		ALP	Control Console	7-20	6-76
	V312		ALP	Control Console	7-20	6-76
	V313		ALP	Control Console	7-20	6-76
	V314		ALP	Control Console	7-20	6-76
Valve, Isolation, HP <i>[NOTE: Double page number references refer to CPV and Circle Seal in Chapter 7 and Circle Seal and CPV in Chapter 6.]</i>	V501		AHP	HP Air Supply	7-22/24	6-42/44
	V502		AHP	HP Air Supply	7-22/24	6-42/44
	V503		AHP	HP Air Supply	7-22/24	6-42/44
	V504		AHP	HP Air Supply	7-22/24	6-42/44
	V601		AHP	Roof Rack Assy	7-22/24	6-50/51
	V604		AHP	Roof Rack Assy	7-20	6-54
Valve, Pilot	V403		ALP	Air Compressor	7-24	6-31

## SS500-HK-MMO-010

Table 7-1. LWDS MK 3 Mod 0 Replacement Parts Index—Continued

Nomenclature	Valve	Gauge	Type	Used On	Page References	
Valve, Plug	V205		ALP	Volume Tank	7-25	6-68
	V208		ALP	Volume Tank	7-25	6-68
	V209		ALP	Volume Tank	7-25	6-68
	V402		ALP	Air Compressor	7-25	6-31
Valve, Regulator, HP <i>[NOTE: Double page number references refer to Circle Seal and Tescom.]</i>	V201		AHP	Volume Tank	7-27/28	6-57/61
	V307		AHP	Control Console	7-27/28	6-80/84
Valve, Relief, HP	V603		AHP	Roof Rack Assy	7-31	6-52
Valve, Relief, LP				Air Compressor	7-9	6-27
	V207		ALP	Volume Tank	7-26	6-70
	V211		ALP	Mod 1 Vol Tank	7-26	6-70
	V308		ALP	Control Console	7-26	6-86
	V315		ALP	Mod 1 Ctrl Console	7-26	6-86
	V404		ALP	Air Compressor	7-30	6-34
Valve, Unloader				Air Compressor	7-9	6-27
Valve, Vent				Air Compressor	7-10	6-28

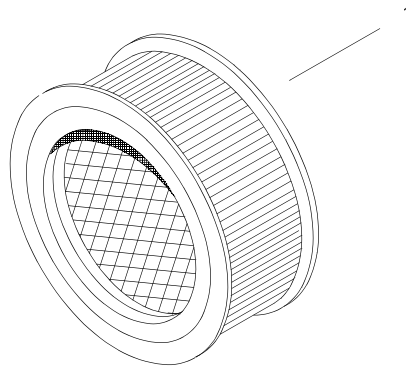
**NOTE:** When ordering parts for the LV2 diesel engine, quote the part number and the number shown on the Lister-Petter engine number plate.



Item	Description	CAGE	NSN	Part No.	Qty.
1	Cylinder head cover, flywheel end	97947	---	601-30490	1
2	Cylinder head cover, gear end	97947	---	602-30491	1
3	Gasket	97947	5330-01-207-7365	601-30511	1 ea.
4	Washer, flat (copper)	97947	5310-01-018-5466	291-26090	2 ea.

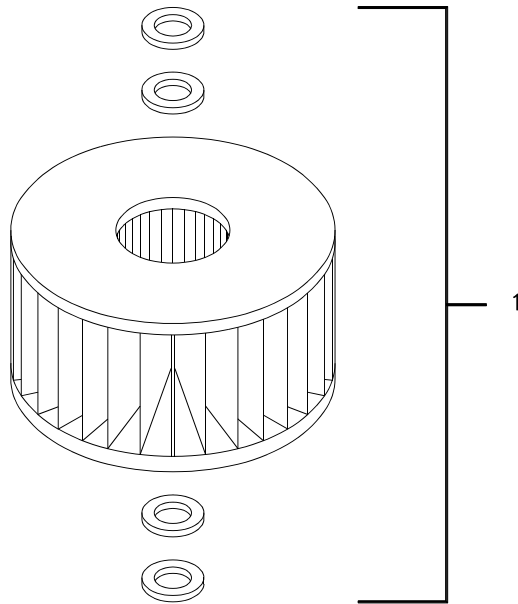
Figure 7-1. Cylinder Head Covers (Diesel Engine)

SS500-HK-MMO-010



Item	Description	CAGE	NSN	Part No.	Qty.
1	Filter element, intake air cleaner	97947	2940-01-131-2135	366-06227	1

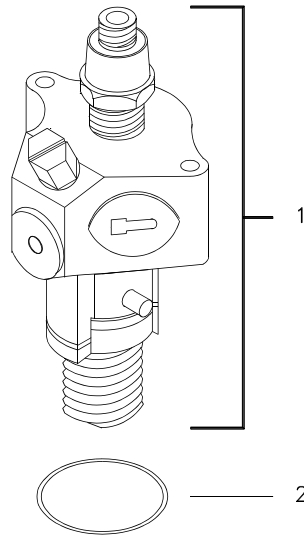
**Figure 7-2. Air Filter Element (Diesel Engine)**



Item	Description	CAGE	NSN	Part No.	Qty.
1	Element assembly	97947	2910-00-099-5467	201-13118	1
	Sealing ring	---	---	---	4
	Element	---	---	---	1

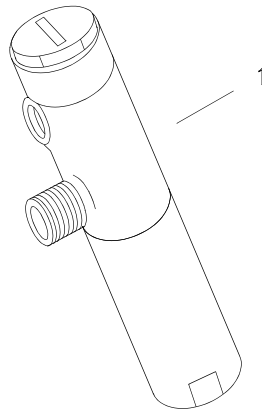
**Figure 7-3. Fuel Filter (Diesel Engine)**

SS500-HK-MMO-010



Item	Description	CAGE	NSN	Part No.	Qty.
1	Fuel pump assembly	97947	2910-01-416-5649	601-40650	1
2	O-ring	97947	5331-01-207-7350	601-20691	1

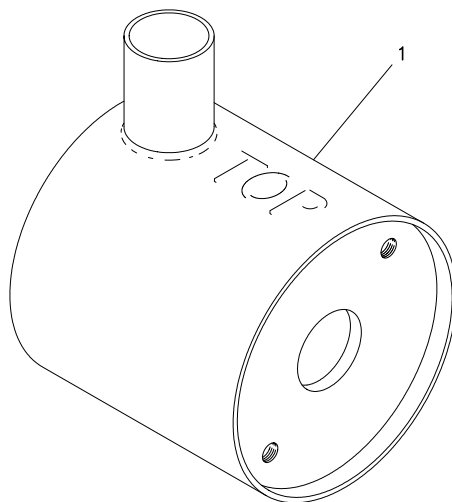
Figure 7-4. Fuel Pump (Diesel Engine)



Item	Description	CAGE	NSN	Part No.	Qty.
1	Fuel injector assembly	97947	2910-01-151-8938	601-36120	1

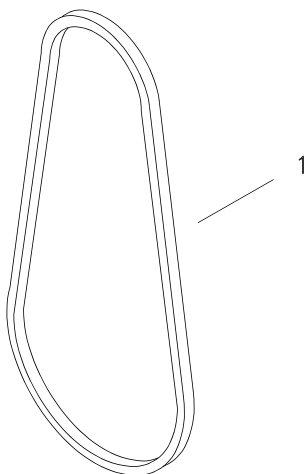
Figure 7-5. Fuel Injector (Diesel Engine)

SS500-HK-MMO-010



Item	Description	CAGE	NSN	Part No.	Qty.
1	Exhaust muffler	97947	---	602-38140	1

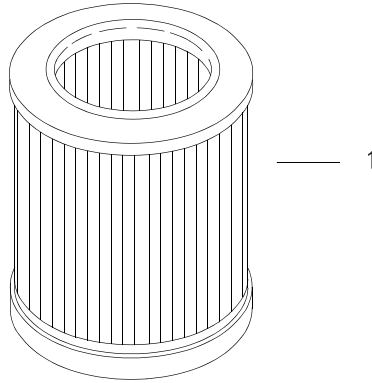
**Figure 7-6. Exhaust Muffler (Diesel Engine)**



Item	Description	CAGE	NSN	Part No.	Qty.
1	Belt, flat	59379	3030-01-416-5647	1310-0352-31	1

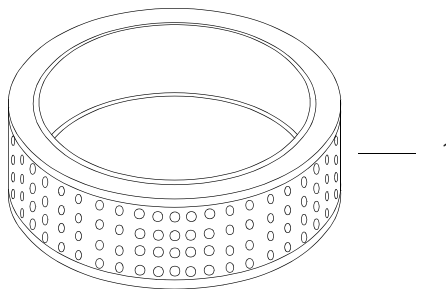
**Figure 7-7. Drive Belt (Air Compressor to Diesel Engine)**

SS500-HK-MMO-010



Item	Description	CAGE	NSN	Part No.	Qty.
1	Filter element, intake air cleaner	73370	4460-01-043-4439	CA568	1

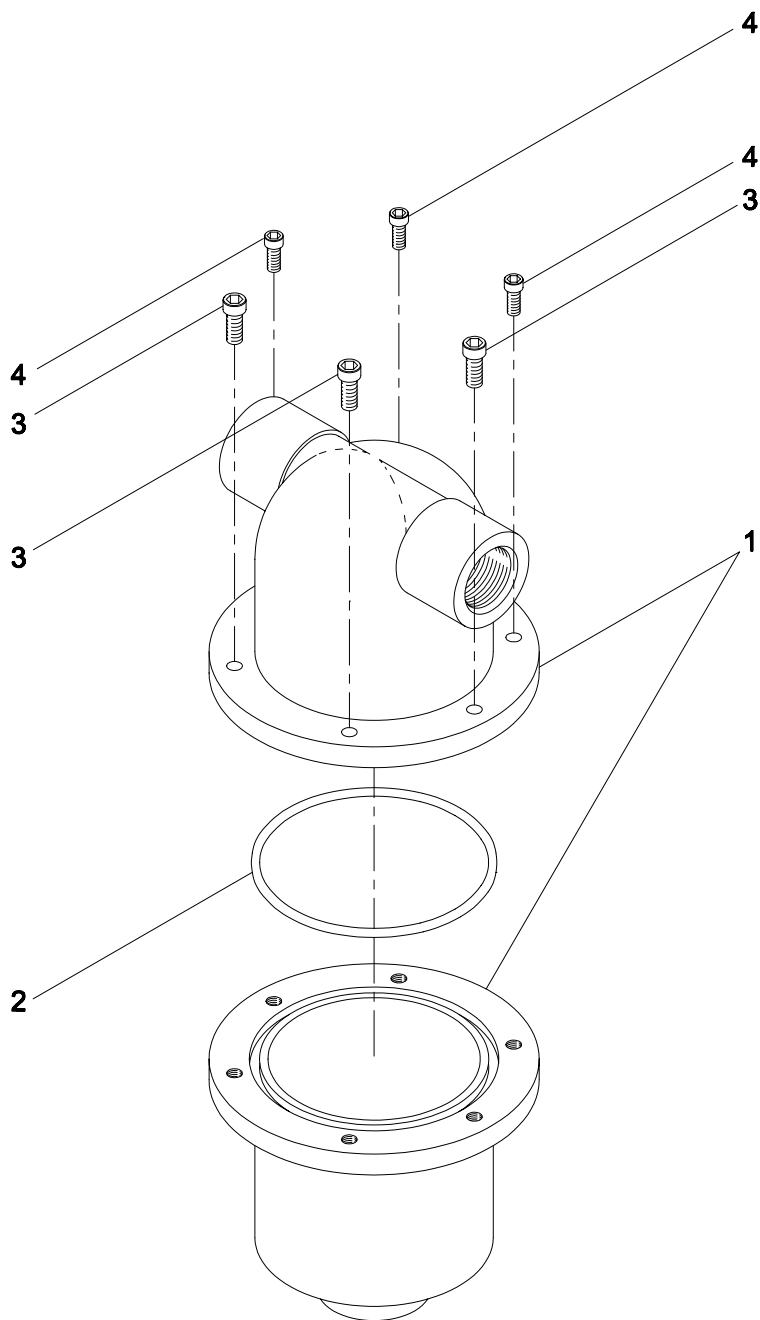
**Figure 7-8. Snorkel Filter Element (Snorkel Assembly)**



Item	Description	CAGE	NSN	Part No.	Qty.
1	Air filter, intake	59379	4330-01-416-5646	1503-0189-00	1

**Figure 7-9. Air Filter (Air Compressor)**

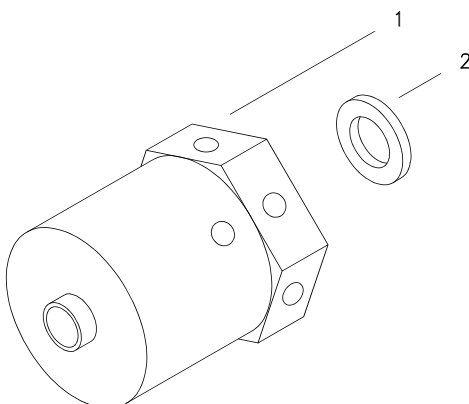
## SS500-HK-MMO-010



Item	Description	CAGE	NSN	Part No.	Qty.
1	Moisture separator	53711	---	6314359	1
2	O-ring	81349	5331-00-165-1955	M83248/1-237	1
3	Screw, cap, socket head-hexagon .312-24UNF x 1.0 LG	39428	---	92197A583	3
4	Screw, cap, socket head-hexagon .250-28UNF x 1.0 LG	39428	---	92197A542	3

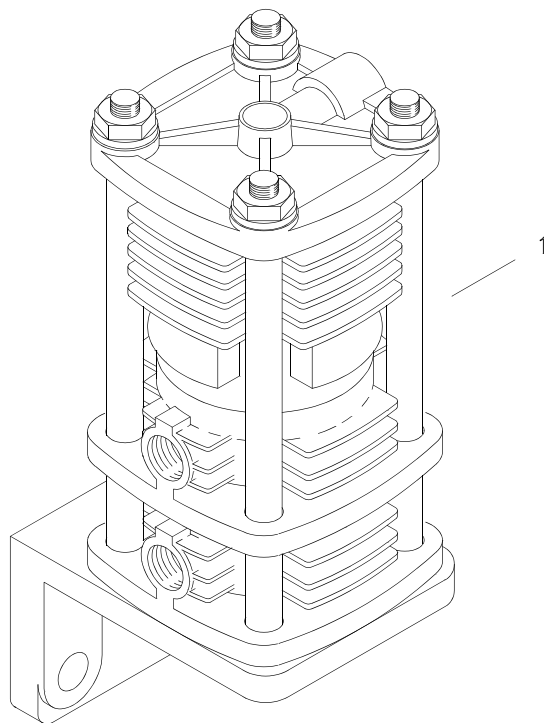
**Figure 7-10. Moisture Separator (Air Compressor)**

SS500-HK-MMO-010



Item	Description	CAGE	NSN	Part No.	Qty.
1	Valve, safety relief	59379	4820-01-416-5619	1503-0494-00	1
2	Gasket	59379	5330-01-416-5575	0653-9078-00	1

Figure 7-11. Relief Valve (Air Compressor)

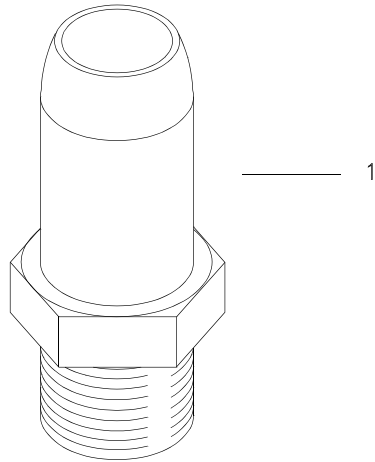


Item	Description	CAGE	NSN	Part No.	Qty.
1	Unloader valve	59379	---	1503-6176-60	1

Figure 7-12. Unloader Valve (Air Compressor)

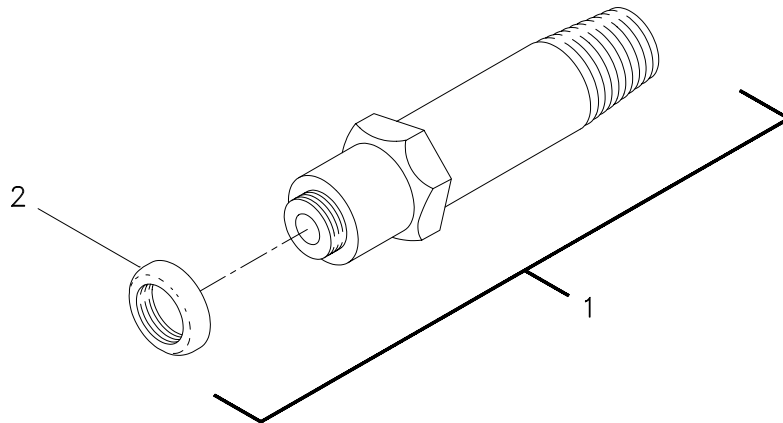


## SS500-HK-MMO-010



Item	Description	CAGE	NSN	Part No.	Qty.
1	Vent valve	59379	4820-01-416-5618	1503-0208-80	1

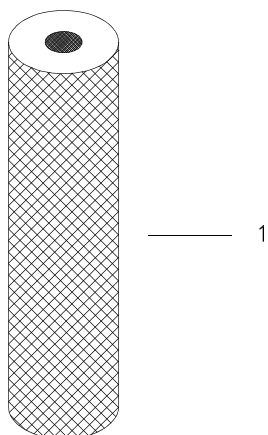
Figure 7-13. Vent Valve (Air Compressor)



Item	Description	CAGE	NSN	Part No.	Qty.
1	Hose Nipple (includes item 2)	16166	4730-01-416-5656	614-5	1
2	Softseat	16166	---	614-KPT	1

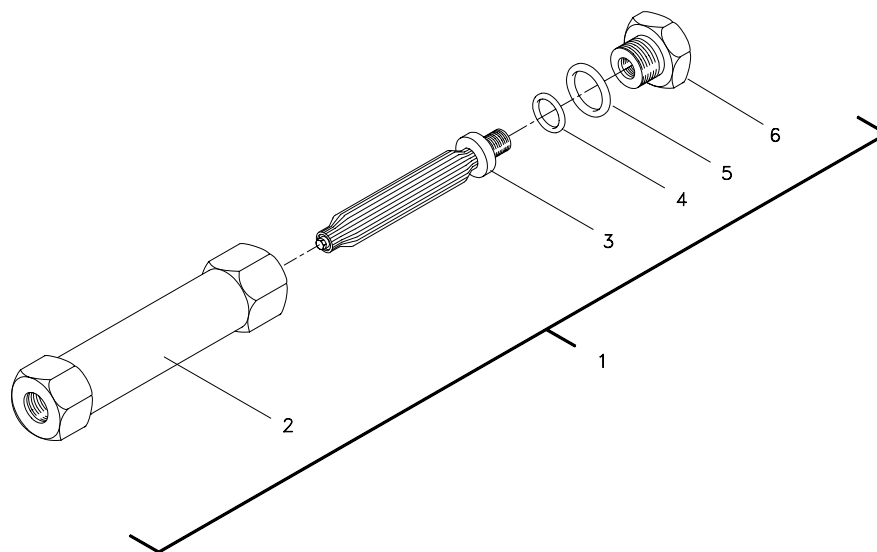
Figure 7-14. Hose Nipple and Softseat (HP Hose Assembly)

SS500-HK-MMO-010



Item	Description	CAGE	NSN	Part No.	Qty.
1	Filter element, fluid	17238	4330-00-864-7737	PFS1001ZM	1
	Alternate PN	17238	4330-00-864-7737	POS1001SU	

Figure 7-15. Filter Element (Volume Tank)

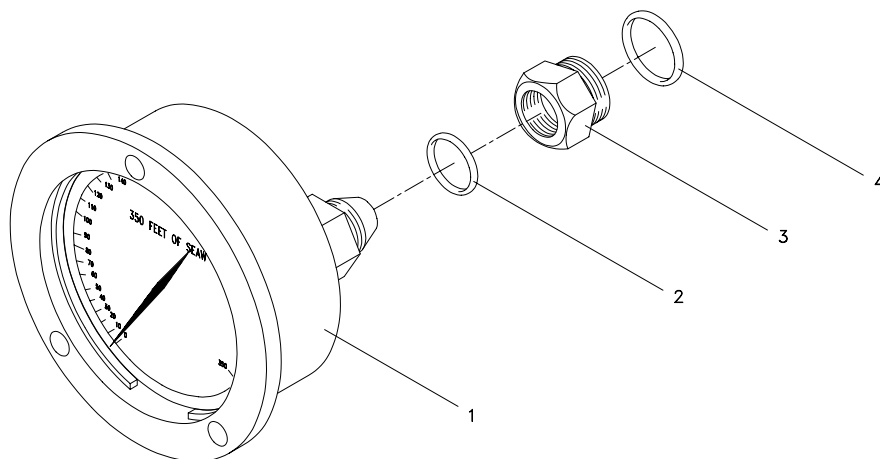


Item	Description	CAGE	NSN	Part No.	Qty.
1	HP supply in-line air filter	59165	4330-01-416-5579	U-281	1
	HP supply in-line air filter*	59165	---	44-13GG10VN*	
2	Housing	59165	REF Item 1	REF Item 1	1
3	Filter element, fluid	59165	4330-01-416-5580	U-282	1
4	O-ring	81349	5330-01-422-9795	M83248/2-906	1
5	O-ring	03950	5331-01-499-4733	M83248/2-914	1
6	Element base	59165	REF Item 1	REF Item 1	1

\* Replacement part for use in Mod 1 volume tank

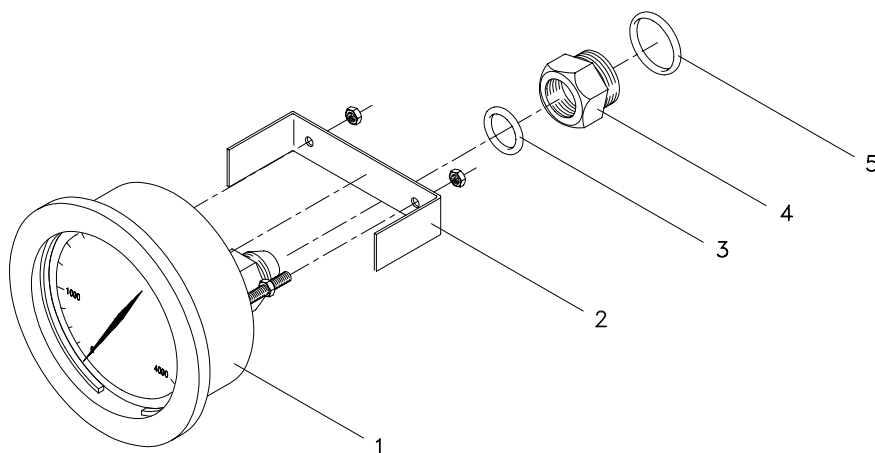
Figure 7-16. HP Supply Air Filter (Volume Tank)

## SS500-HK-MMO-010



Item	Description	CAGE	NSN	Part No.	Qty.
1	Diver depth gauge, green	52159	4240-01-421-2141	25544-24H22-CBD-MBW	1
	Diver depth gauge, red	52159	4220-01-416-5627	25544-24H23-CBD-MBW	1
	Diver depth gauge, yellow	52159	4220-01-422-5119	25544-24H24-CBD-MBW	1
2	O-ring	03950	5331-01-096-8824	M83248/2-904	1 ea.
3	Snubber, modified	53711	---	53711-6314404	1 ea.
4	O-ring, face seal	03950	5330-01-096-8821	M83248/2-113	1 ea.

**Figure 7-17. Diver Depth Gauges (ALP-G318, ALP-G319, ALP-G320)**



Item	Description	CAGE	NSN	Part No.	Qty.
1	Pressure gauge, 0-4000 psig*	52159	4240-01-416-5584	25502-34H21-MBV	1
	Pressure gauge, 0-6000 psig**	52159	---	25502-36H21-MBV	1
2	Gauge mounting kit***	52159	5340-01-427-8438	RS-426-1	1
3	O-ring	03950	5331-01-096-8824	M83248/2-904	1
4	Snubber	02570	6685-01-433-5549	SS-10-SVCO-7-4ST-EA	1
5	O-ring, face seal	03950	5330-01-096-8821	M83248/2-113	1

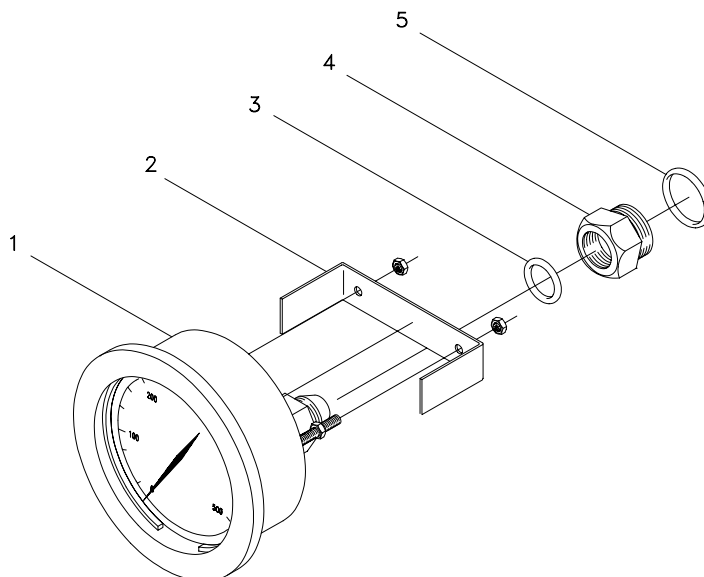
\* The 0-4000 psig gauges (AHP-G211, AHP-G316, AHP-G508, AHP-G602) are used in the Mod 0.

\*\* The 0-6000 psig gauges (also designated AHP-G211 and AHP-G316) are used in the Mod 1.

\*\*\* The kit contains one mounting bracket, two threaded posts (studs), and two nylon locknuts (hex nuts).

**Figure 7-18. HP Pressure Gauges (AHP-G211, AHP-G316, AHP-G508, AHP-G602)**

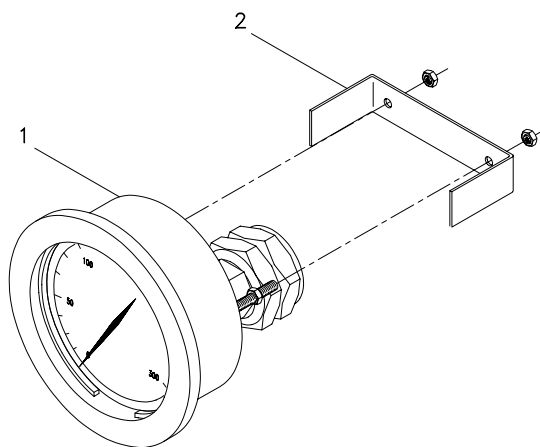
SS500-HK-MMO-010



Item	Description	CAGE	NSN	Part No.	Qty.
1	Pressure gauge, 0-500 psig	52159	4240-01-416-5582	25502-27H21-MBV	1
2	Gauge mounting kit*	52159	5340-01-427-8438	RS-426-1	1
3	O-ring	03950	5331-01-096-8824	M83248/2-904	1
4	Snubber	02570	6685-01-433-5549	SS-10-SVCO-7-4ST-EA	1
5	O-ring, face seal	03950	5330-01-096-8821	M83248/2-113	1

\* Kit contains one mounting bracket, two threaded posts (studs), and two nylon locknuts (hex nuts)

**Figure 7-19. LP Pressure Gauges (ALP-G212, ALP-G315, ALP-G317)**

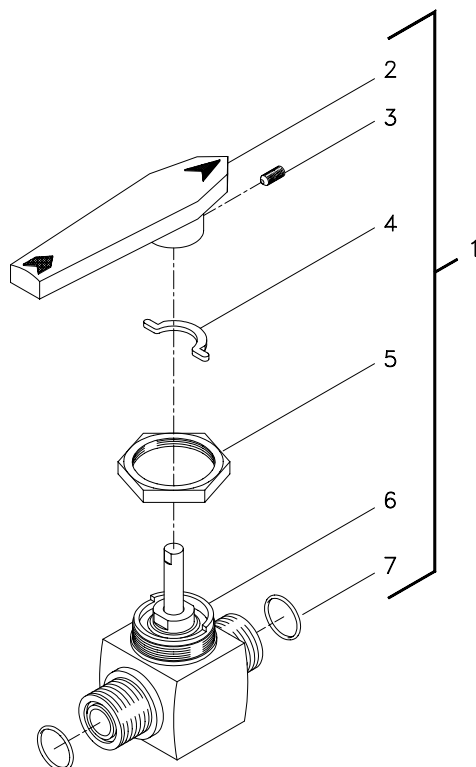


Item	Description	CAGE	NSN	Part No.	Qty.
1	Pressure gauge, 0-300 psig with snubber	52159	4220-01-416-5620	25502-26B21 WITH GP140KTB-MBY	1
2	Gauge mounting kit*	52159	5340-01-427-8438	RS-426-1	1

\* Kit contains one mounting bracket, two threaded posts (studs), and two nylon locknuts (hex nuts)

**Figure 7-20. LP Pressure Gauge (ALP-G406)**

## SS500-HK-MMO-010



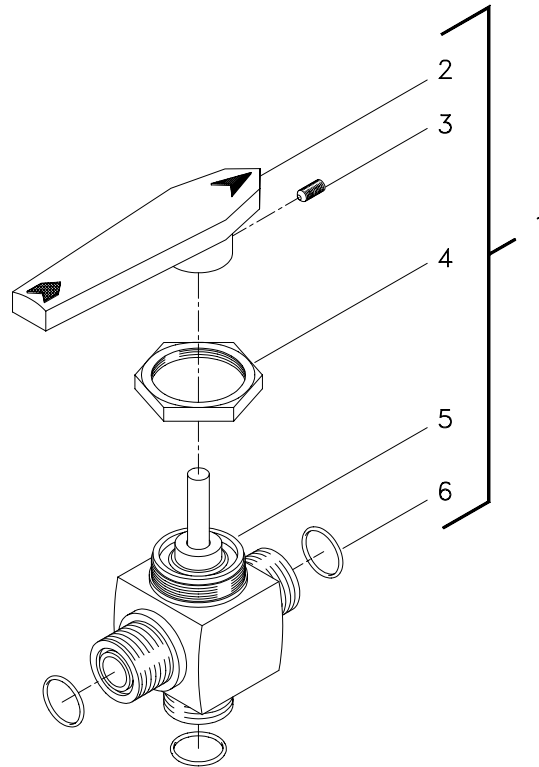
Item	Description	CAGE	NSN	Part No.	Qty.
1	Ball valve, black <sup>1</sup>	12623	4820-01-421-2144	SS-45TVCO-8	1
	Ball valve, red <sup>2</sup>	12623	4820-01-421-2147	SS-45TVCO-8-RD	1
	Ball valve, green <sup>3</sup>	12623	4820-01-416-5590	SS-45TVCO-8-GR	1
	Ball valve, yellow <sup>4</sup>	12623	4820-01-416-5592	SS-45TVCO-8-YW	1
2	Handle, black <sup>1</sup>	12623	5355-01-413-1235	BZ-5K-45-BK	1
	Handle, red <sup>2</sup>	12623	---	BZ-5K-45-RD	1
	Handle, green <sup>3</sup>	12623	---	BZ-5K-45-GR	1
	Handle, yellow <sup>4</sup>	12623	---	BZ-5K-45-YW	1
3	Setscrew	12623	REF Item 2	REF Item 2	1 ea.
4	Handle stop insert	12623	---	188-5C-45	1 ea.
5	Panel nut	12623	---	SS-7-45	1 ea.
6	Body	12623	REF Item 1	REF Item 1	1 ea.
7	O-ring, face seal	03950	5330-01-090-4117	M83248/2-111	2 ea.

- 1 ALP-V210 — Black handle
- 2 ALP-V304 — Red handle
- 3 ALP-V305 — Green handle
- 4 ALP-V306 — Yellow handle

Note: Remove and discard vendor supplied O-rings from new valve and replace with Item 7.

**Figure 7-21. Ball Valves (ALP-V210, ALP-V304, ALP-V305, ALP-V306)**

SS500-HK-MMO-010

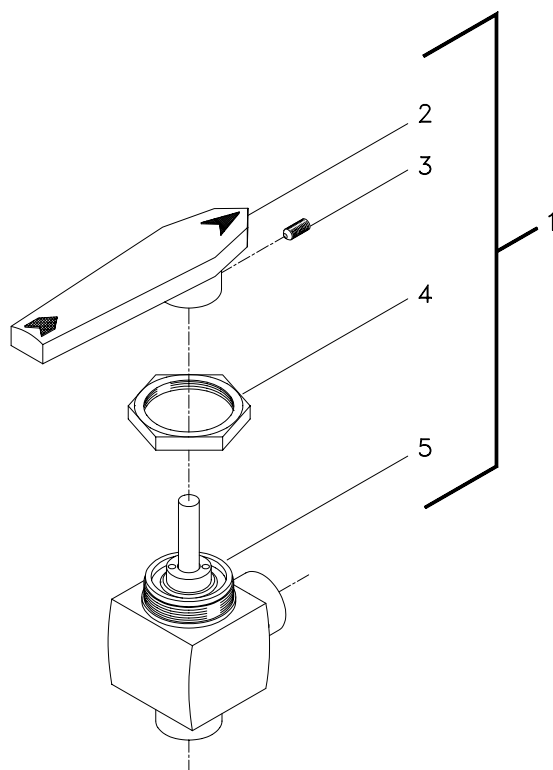


Item	Description	CAGE	NSN	Part No.	Qty.
1	Ball valve	12623	4820-01-421-2149	SS-45TXVCO-8	1
2	Handle, black	12623	5355-01-413-1235	BZ-5K-45-BK	1
3	Setscrew	12623	REF Item 2	REF Item 2	1
4	Panel nut	12623	---	SS-7-45	1
5	Body	12623	REF Item 1	REF Item 1	1
6	O-ring, face seal	03950	5330-01-090-4117	M83248/2-111	3

Note: Remove and discard vendor supplied O-rings from new valve and replace with Item 6.

**Figure 7-22. Ball Valve (ALP-V302)**

## SS500-HK-MMO-010

**PARTS LIST FOR ALP-V401**

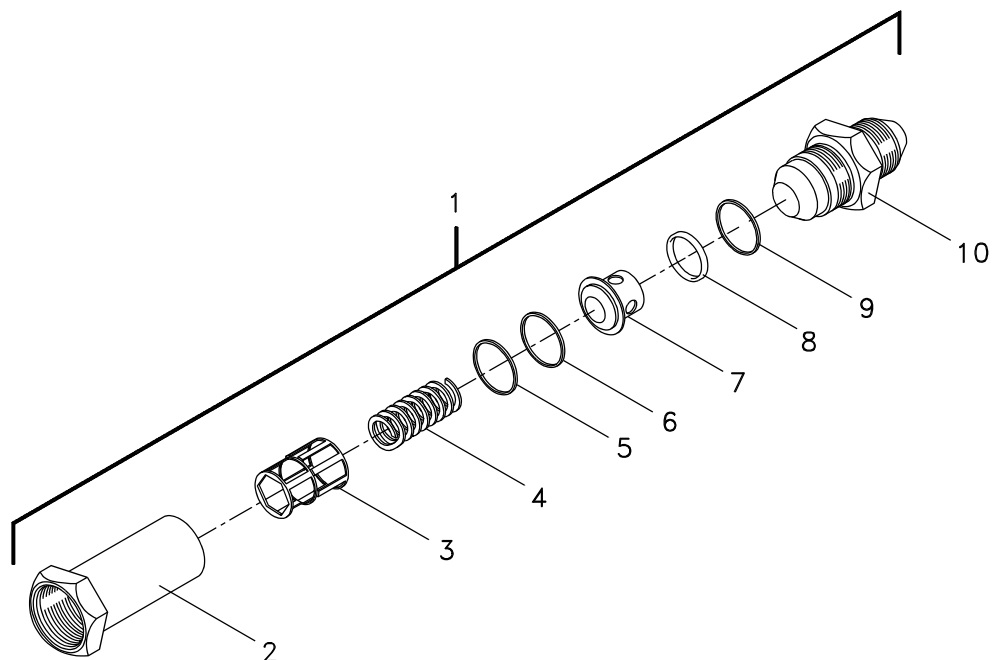
Item	Description	CAGE	NSN	Part No.	Qty.
1	Ball valve, 1/2 NPT	12623	4820-01-416-5573	SS-45TF8-A	1
2	Handle, black, 1/2 NPT	12623	5355-01-413-1235	BZ-5K-45-BK	1
3	Setscrew	12623	REF Item 2	REF Item 2	1
4	Panel nut for 1/2 NPT	12623	---	SS-7-45	1
5	Body	12623	REF Item 1	REF Item 1	1

**PARTS LIST FOR ALP-V405**

Item	Description	CAGE	NSN	Part No.	Qty.
1	Ball valve, 1/4 NPT	12623	4820-01-416-5572	SS-43TF4-A	1
2	Handle, black, 1/4 NPT	12623	5355-01-173-7842	BZ-5K-43-BK	1
3	Setscrew	12623	REF Item 2	REF Item 2	1
4	Panel nut for 1/4 NPT	12623	5310-01-301-3485	SS-7-16	1
5	Body	12623	REF Item 1	REF Item 1	1

**Figure 7-23. Ball Valves (ALP-V401, ALP-V405)**

## SS500-HK-MMO-010

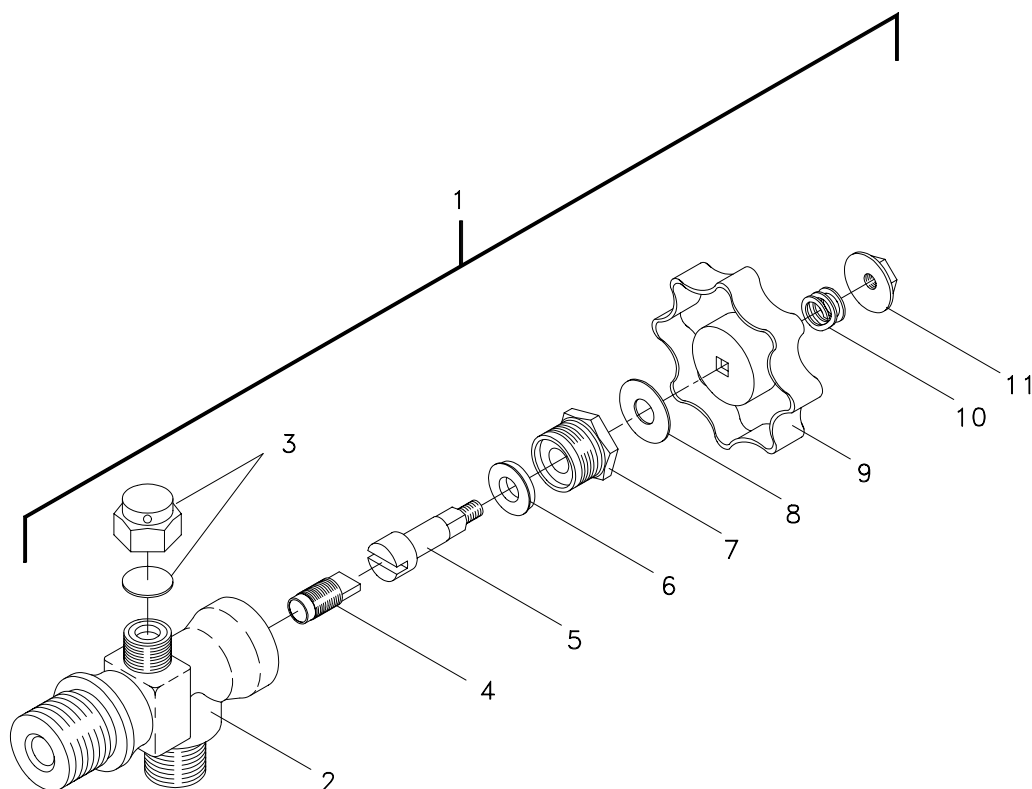


Item	Description	CAGE	NSN	Part No.	Qty.
1	Check valve	91816	4820-01-419-3940	CV02-142	1
2	Housing	91816	---	C283T1	1
3	Spring guide	91816	---	12852	1
4	Spring	91816	5360-00-775-1551	255	1
5	Back-up ring	91816	---	10293T	1
6	Gasket	91816	5330-01-436-1246	10292	1
7	Poppet	91816	---	A253T1	1
8	O-ring, Viton (AS568-112)	91816	5331-01-310-5194	4112-32	1
9	Back-up ring	91816	---	A10291T	1
10	End	91816	---	B295T1	1
N/A	Repair kit (Includes items 5, 6, 8, 9)	91816	---	CV02-142KIT	1
ATTACHING O-RINGS FOR ALP-V206					
N/A	O-ring, face seal, valve adapter	03950	5330-01-090-4117	M83248/2-111	1
N/A	O-ring, straight thread, valve adapter and check valve	03950	5331-01-097-2778	M83248/2-908	2
ATTACHING O-RINGS FOR ALP-V303					
N/A	O-ring, face seal, ALP-V302 and tee adapters	03950	5330-01-090-4117	M83248/2-111	3
N/A	O-ring, straight thread, valve adapter and check valve	03950	5331-01-097-2778	M83248/2-908	2

Figure 7-24. Check Valves (ALP-V206, ALP-V303)



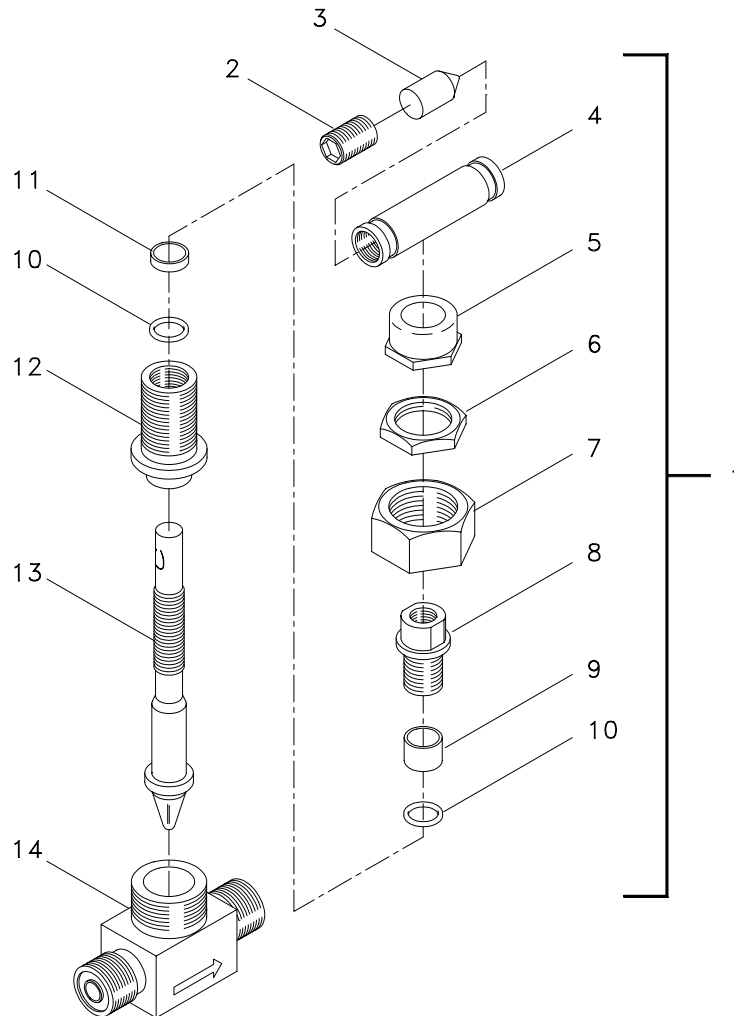
## SS500-HK-MMO-010



Item	Description	CAGE	NSN	Part No.	Qty.
1	Flask valve	05LN3	4820-01-416-5631	12346X1312-20P	1
2	Valve body	05LN3	REF Item 1	REF Item 1	1
3	Safety assembly (includes rupture disk)	05LN3	---	20P-CP	1
4	Seat plug	05LN3	---	206-55K	1
5	Stem	05LN3	---	206-2	1
6	Packing	05LN3	---	306-6	1
7	Packing nut	05LN3	---	306-3CP	1
8	Thrust washer	05LN3	---	306-14	1
9	Handwheel	05LN3	---	306-5CP	1
10	Spring	05LN3	---	306-11	1
11	Handwheel nut	05LN3	---	306-17CP	1
N/A	Rebuild kit (Includes items 4 and 6)	05LN3	---	1200X	1
N/A	O-ring	81349	5331-01-503-6343	M83248/2-916	1

**Figure 7-25. Flask Shutoff Valves (AHP-V505, AHP-V506, AHP-V507)**

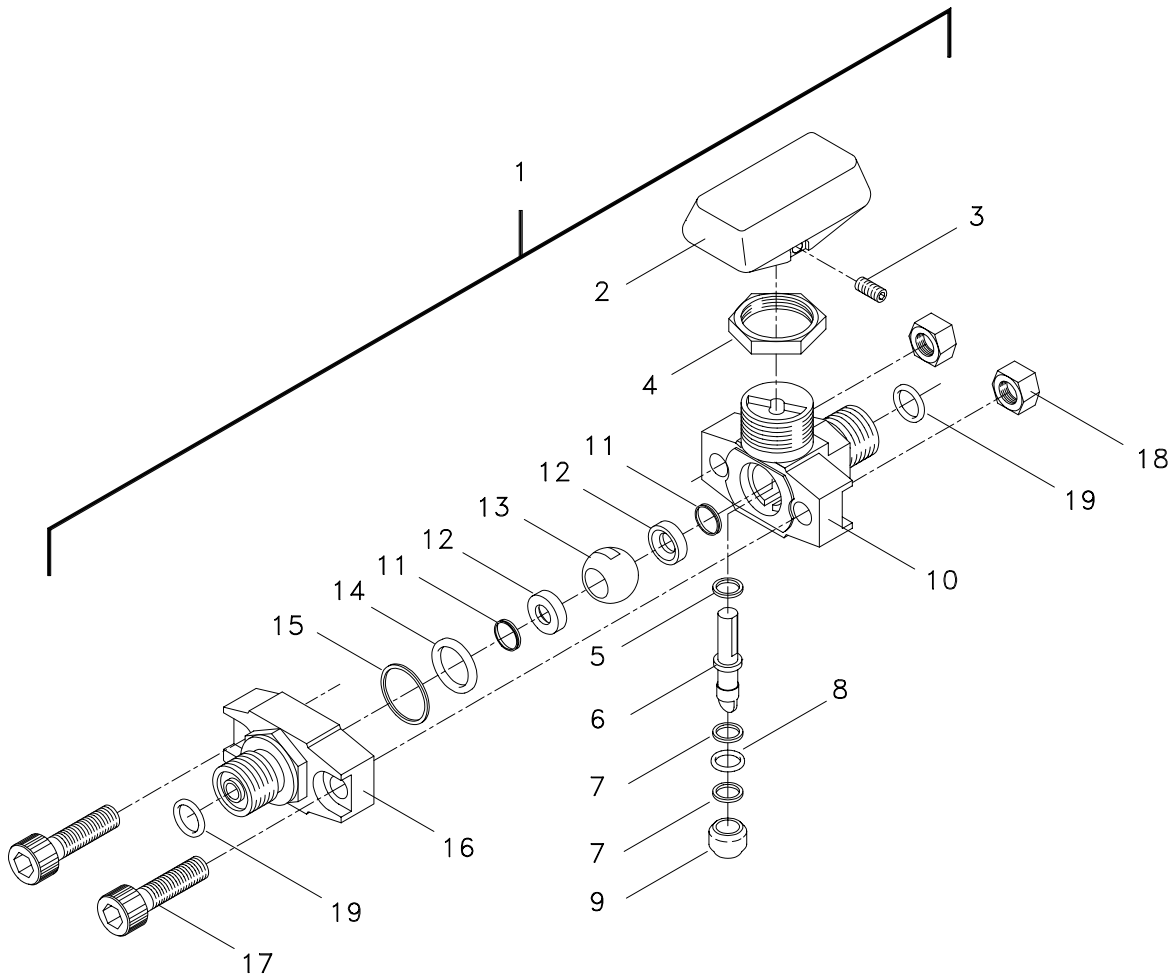
## SS500-HK-MMO-010



Item	Description	CAGE	NSN	Part No.	Qty.
1	Shutoff valve, 1/4 tube	12623	4220-01-419-3929	SS-3NBVCO4	1
2	Setscrew	12623	REF Item 4	REF Item 4	1
3	Handle pin	12623	REF Item 4	REF Item 4	1
4	Handle	12623	5340-01-425-2402	A-5K-14B-BK	1
5	Locknut	12623	4820-01-421-2139	SS-11A-3N	1
6	Panel nut	12623	5310-01-372-0343	SS-7-2	1
7	Union nut	12623	REF Item 1	REF Item 1	1
8	Packing bolt	12623	REF Item 1	REF Item 1	1
9	Gland	12623	REF Item 1	REF Item 1	1
10	Packing support	12623	REF Item 1	REF Item 1	2
11	Packing	12623	REF Item 1	REF Item 1	1
12	Bonnet	12623	REF Item 1	REF Item 1	1
13	Stem	12623	REF Item 1	REF Item 1	1
14	Body	12623	REF Item 1	REF Item 1	1
N/A	Stem packing kit (Includes items 10, 11)	12623	5330-01-160-9733	T-9K-3N	1
N/A	O-ring, face seal	03950	5330-01-090-4116	M83248/2-010	2

Figure 7-26. HP Gauge Isolation Valves (AHP-V202, AHP-V309)

SS500-HK-MMO-010



**Figure 7-27. LP Gauge Isolation Valves (ALP-V204, ALP-V301, ALP-V310, ALP-V312, ALP-V313, ALP-V314) and HP Isolation Valve (AHP-V604) (Sheet 1 of 2)**

## SS500-HK-MMO-010

Item	Description	CAGE	NSN	Part No.	Qty.
1	Ball valve, black handle <sup>1</sup>	12623	4820-01-421-2138	SS-33VVCO4	1
	Ball valve, red handle <sup>2</sup>	12623	4820-01-421-2137	SS-33VVCO4-RD	
	Ball valve, green handle <sup>3</sup>	12623	4820-01-421-2145	SS-33VVCO4-GR	
	Ball valve, yellow handle <sup>4</sup>	12623	4820-01-421-2143	SS-33VVCO4-YW	
2	Handle, black <sup>1</sup>	12623	---	SS-5K-33K-BK	1
	Handle, red <sup>2</sup>	12623	---	SS-5K-33K-RD	
	Handle, green <sup>3</sup>	12623	---	SS-5K-33K-GR	
	Handle, yellow <sup>4</sup>	12623	---	SS-5K-33K-YW	
3	Setscrew	12623	REF Item 2	REF Item 2	1
4	Panel nut	12623	5310-01-301-3485	SS-7-16	1
5	Stem bearing	12623	REF kit	REF kit	1
6	Stem	12623	REF Item 1	REF Item 1	1
7	Stem back-up ring	12623	REF kit	REF kit	2
8	Stem O-ring	12623	REF kit	REF kit	1
9	Stem bushing	12623	REF kit	REF kit	1
10	Body half	12623	REF Item 1	REF Item 1	1
11	Seat quad ring	12623	REF kit	REF kit	2
12	Seat	12623	REF kit	REF kit	2
13	Stem ball	12623	REF Item 1	REF Item 1	1
14	End piece O-ring	12623	REF kit	REF kit	1
15	End piece back-up ring	12623	REF kit	REF kit	1
16	Body half	12623	REF Item 1	REF Item 1	1
17	Socket head bolt	12623	REF Item 1	REF Item 1	2
18	Hex nut	12623	REF Item 1	REF Item 1	2
19	O-ring, face seal	03950	5330-01-090-4116	M83248/2-010	2
N/A	Parts kit (Includes items 5, 7, 8, 9, 11, 12, 14, 15)	12623	4820-01-421-2140	T91K-33	1

1 ALP-V204, ALP-V301, ALP-V310, and AHP-V604

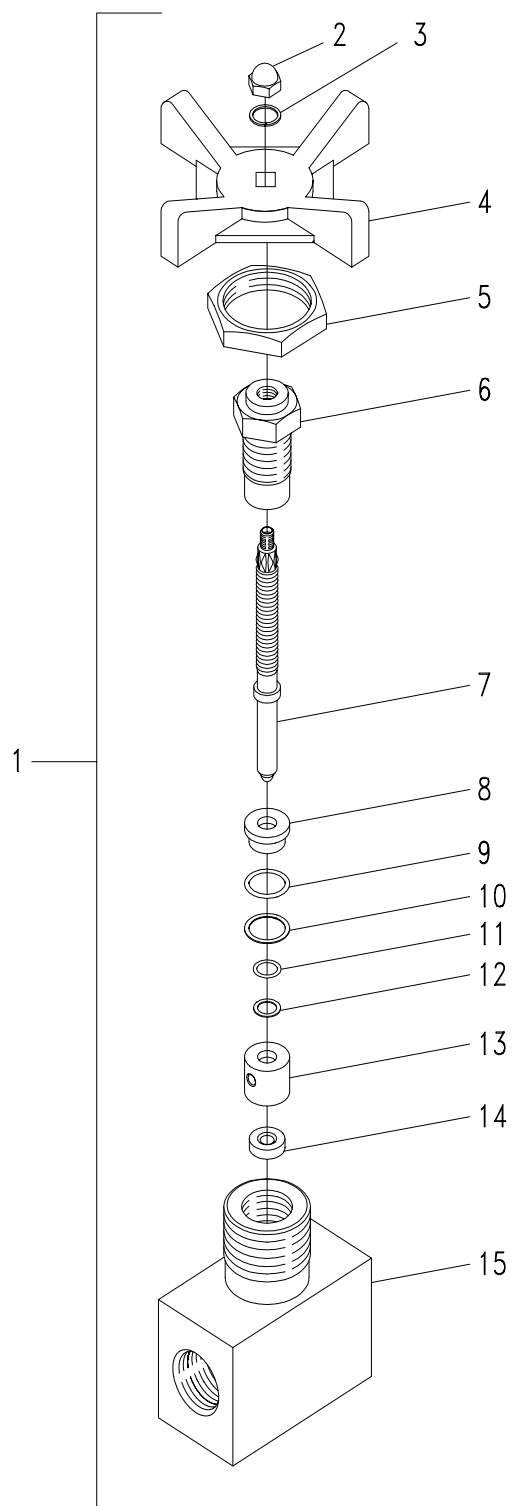
2 ALP-V312

3 ALP-V313

4 ALP-V314

**Figure 7-27. LP Gauge Isolation Valves (ALP-V204, ALP-V301, ALP-V310, ALP-V312, ALP-V313, ALP-V314) and HP Isolation Valve (AHP-V604) (Sheet 2)**

SS500-HK-MMO-010



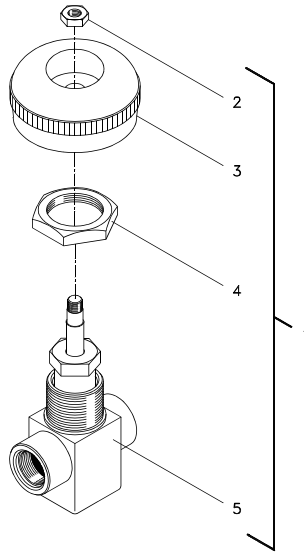
**Figure 7-28. CPV HP Isolation Valves (AHP-V501, AHP-V502, AHP-V503, AHP-V504, AHP-V601) (Sheet 1 of 2)**

## SS500-HK-MMO-010

Item	Description	CAGE	NSN	Part No.	Qty.
1	Shutoff valve	99565	---	PLB-12762	1
2	Nut	99565	---	001301CA	1
3	Lock washer	99565	5310-01-246-2665	004209CA	1
4	Handle	99565	---	127990DL	1
5	Panel nut	99565	---	127980AG	1
6	Gland nut	99565	---	127940AC	1
7	Stem	99565	---	127930DC	1
8	Spacer	99565	---	127960AG	1
9	Back-up ring	99565	---	011013EL	1
10	O-ring	99565	---	000013EE	1
11	Back-up ring	99565	---	011010EL	1
12	O-ring	99565	5331-01-414-8467	000010EE	1
13	Sleeve	99565	---	127950AG	1
14	Disc	99565	---	127970ER	1
15	Body	99565	---	127910CG	1
ATTACHING O-RINGS FOR AHP-V501, AHP-V502, AHP-V504					
N/A	O-ring, straight thread, union connector and adapter	81349	5330-01-422-9795	M83248/2-906	3
ATTACHING O-RINGS FOR AHP-V503					
N/A	O-ring, face seal, positionable elbow	03950	5330-01-090-4117	M83248/2-111	1
N/A	O-ring, straight thread, union connector and pos. elbow	81349	5330-01-422-9795	M83248/2-906	3
ATTACHING O-RINGS FOR AHP-V601					
N/A	O-ring, straight thread, male connectors	81349	5330-01-422-9795	M83248/2-906	2
N/A	O-ring, face seal, male connectors	03950	5330-01-090-4116	M83248/2-010	2

**Figure 7-28. CPV HP Isolation Valves (AHP-V501, AHP-V502, AHP-V503, AHP-V504, AHP-V601) (Sheet 2 of 2)**

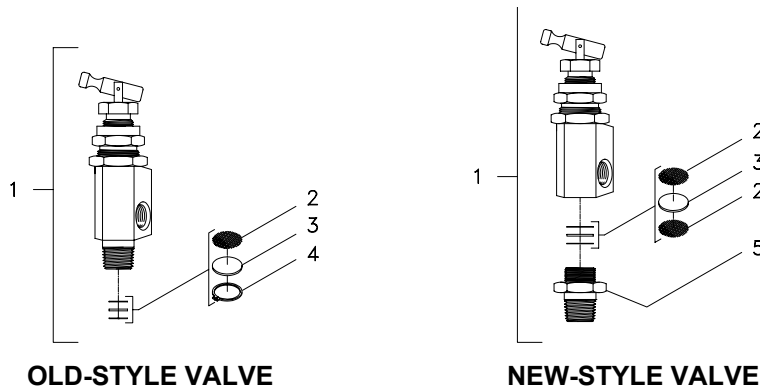
SS500-HK-MMO-010



Item	Description	CAGE	NSN	Part No.	Qty.
1	Shutoff valve	91816	4820-01-416-5630	HV09-7	1
2	Stem nut	91816	---	6521SC	1
3	Handle	91816	---	26689	1
4	Panel nut	91816	---	6524SC	1
5	Body	91816	---	12978-3	1
N/A	Repair kit (Includes 1 seal, 3 O-rings, and 3 back-up rings)	91816	4220-01-462-9454	17314	1

Note: See Figure 7-28 for attaching O-rings.

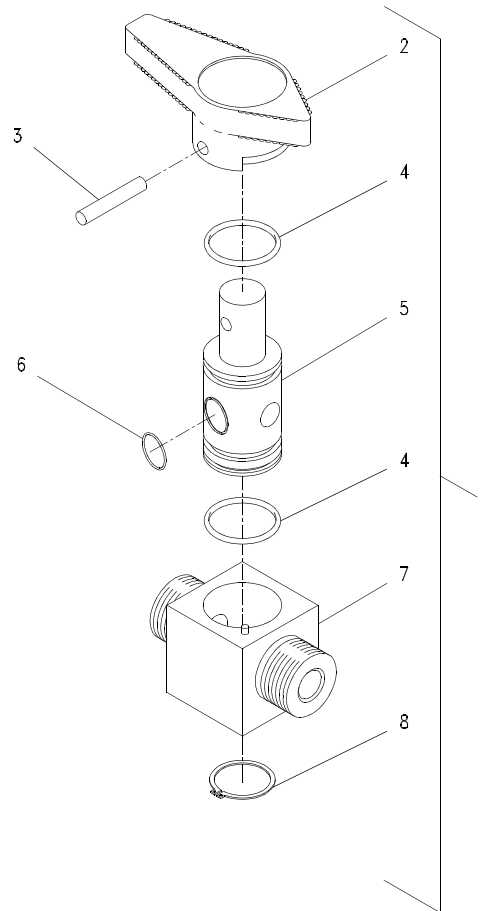
**Figure 7-29. Circle Seal HP Isolation Valves (AHP-V501, AHP-V502, AHP-V503, AHP-V504, AHP-V601)**



Item	Description	CAGE	NSN	Part No.	Qty.
1	Pilot valve	71647	4820-01-416-5653	RCB-M-HU-SS	1
2	Filter screen	71647	---	0358	2
3	Filter felt	71647	---	0357	1
4	Filter ring (old-style only)	71647	---	0440	1
5	Filter nut (new-style only)	71647	---	0723	1
N/A	O-ring, bulkhead connector	81349	5330-01-422-9795	M83248/2-906	1

**Figure 7-30. Pilot Valve (ALP-V403)**

## SS500-HK-MMO-010

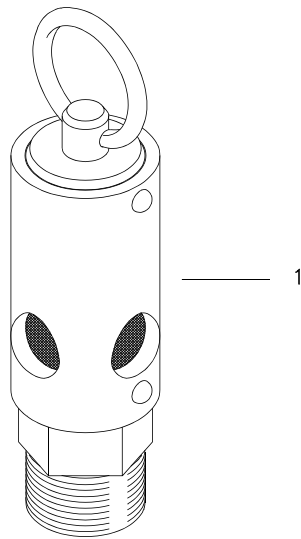


Item	Description	CAGE	NSN	Part No.	Qty.
1	Plug valve, 1/4 male NPT	18034	4820-01-121-0846	SS-4P4T2	1
2	Handle	18034	---	PHEN-P4T-K4-GR	1
3	Pin	18034	REF Item 2	REF Item 2	1
4	O-ring	18034	REF kit	REF kit	2
5	Valve stem	18034	REF Item 1	REF Item 1	1
6	O-ring	18034	REF kit	REF kit	1
7	Body	18034	REF Item 1	REF Item 1	1
8	Clip	18034	REF Item 1	REF Item 1	1
N/A	O-ring kit (Includes items 4, 6)	18034	5331-01-416-5574	V1-P4T-K2	1

**Figure 7-31. Plug Valves (ALP-V205, ALP-V208, ALP-V209, ALP-V402)**



## SS500-HK-MMO-010

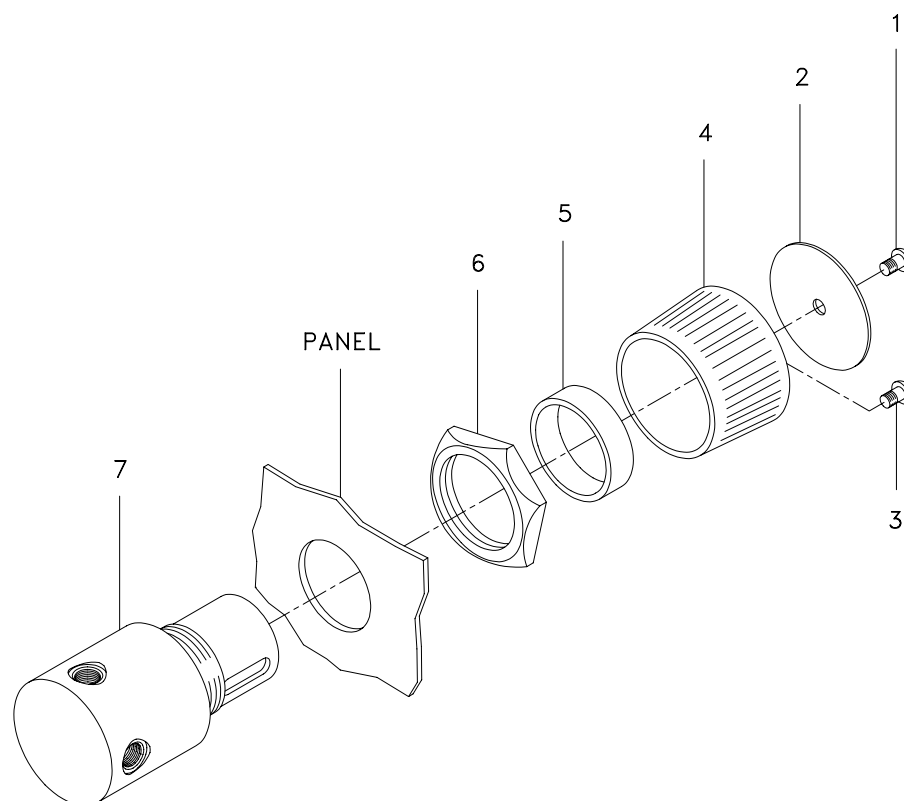


Item	Description	CAGE	NSN	Part No.	Qty.
1	LP relief valve, 1/2 NPT	91816	---	M5132N-4ML-275 ASME	1

Note: ALP-V207 and ALP-V308 are used in both the Mod 0 and Mod 1 volume tank and control console assemblies. ALP-V211 and ALP-V315 are used as additional relief valves in the Mod 1 volume tank and control console assemblies to handle the higher pressure requirements. Since the valves are identical, ordering information is the same for all four valves.

**Figure 7-32. LP Relief Valves (ALP-V207, ALP-V211, ALP-V308, ALP-V315)**

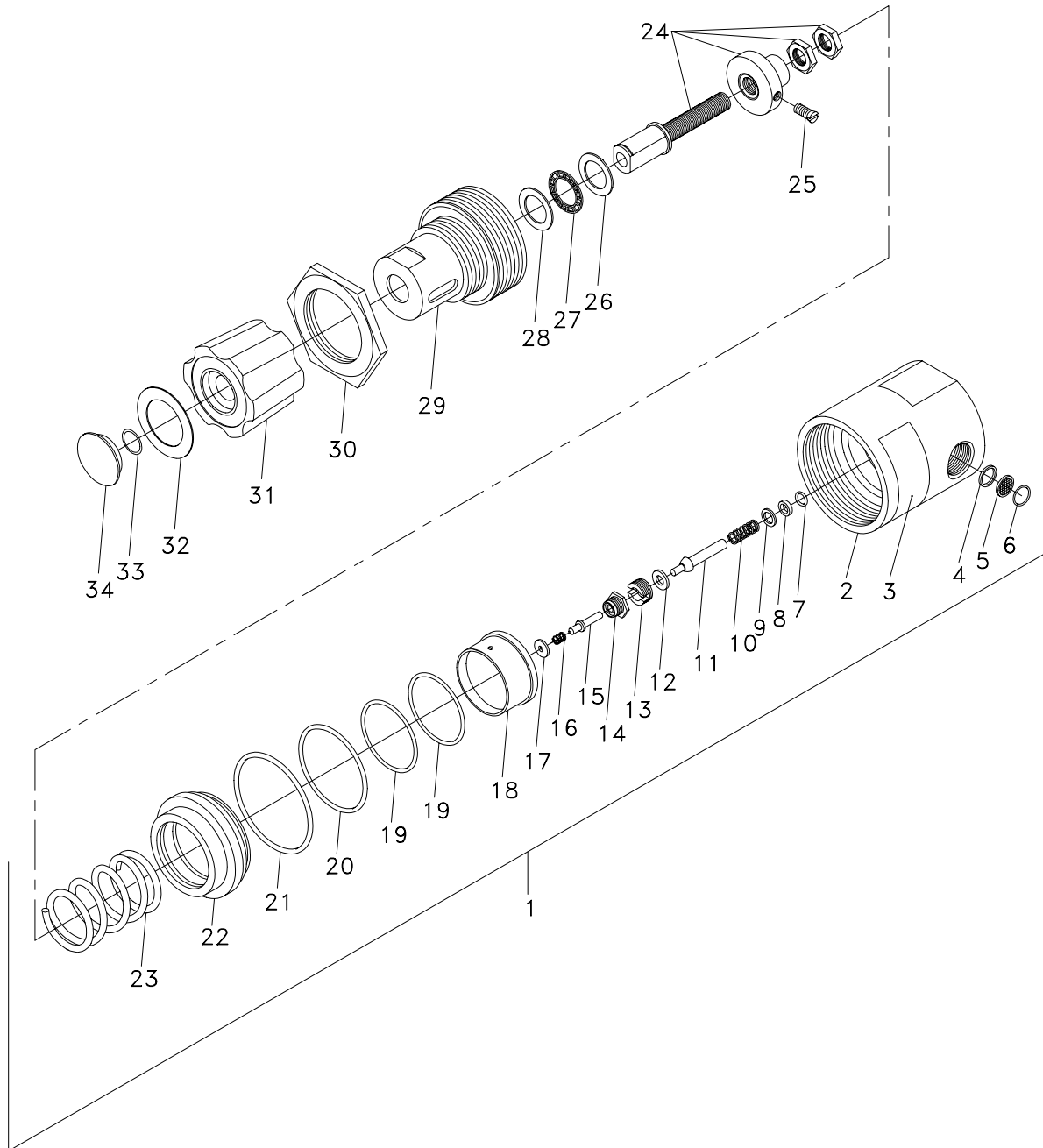
## SS500-HK-MMO-010



Item	Description	CAGE	NSN	Part No.	Qty.
N/A	High pressure regulator assembly	91816	4820-01-416-5583	PR50-6	1
1	Screw	91816	---	2300-0260	1
2	Data plate	91816	---	2245-0145	1
3	Screw	91816	---	2300-0259	3
4	Handle	91816	---	2235-0075	1
5	Sleeve	91816	4820-01-021-6361	2238-0093	1
6	Panel nut	91816	---	2303-0237	1
7	Body	91816	REF Item 1	REF Item 1	1
ATTACHING O-RINGS FOR AHP-V201					
N/A	O-ring, straight thread, union connector and positionable union	03950	5331-01-097-2778	M83248/2-908	2
N/A	O-ring, straight thread, elbow and bleeder plugs	03950	5331-01-096-8824	M83248/2-904	3
N/A	O-ring, face seal, elbow and tee adapters	03950	5330-01-090-4117	M83248/2-111	3
N/A	O-ring, face seal, elbow	03950	5330-01-090-4116	M83248/2-010	1
ATTACHING O-RINGS FOR AHP-V307					
N/A	O-ring, straight thread, elbow and positionable union	03950	5331-01-097-2778	M83248/2-908	2
N/A	O-ring, straight thread, elbows and bleeder plug	03950	5331-01-096-8824	M83248/2-904	3
N/A	O-ring, face seal, elbow and tee adapter	03950	5330-01-090-4117	M83248/2-111	2
N/A	O-ring, face seal, elbows	03950	5330-01-090-4116	M83248/2-010	2

Figure 7-33. Circle Seal HP Regulators (AHP-V201, AHP-V307)

### SS500-HK-MMO-010



**Figure 7-34. Tescom HP Regulators (AHP-V201, AHP-V307) (Sheet 1 of 2)**

## SS500-HK-MMO-010

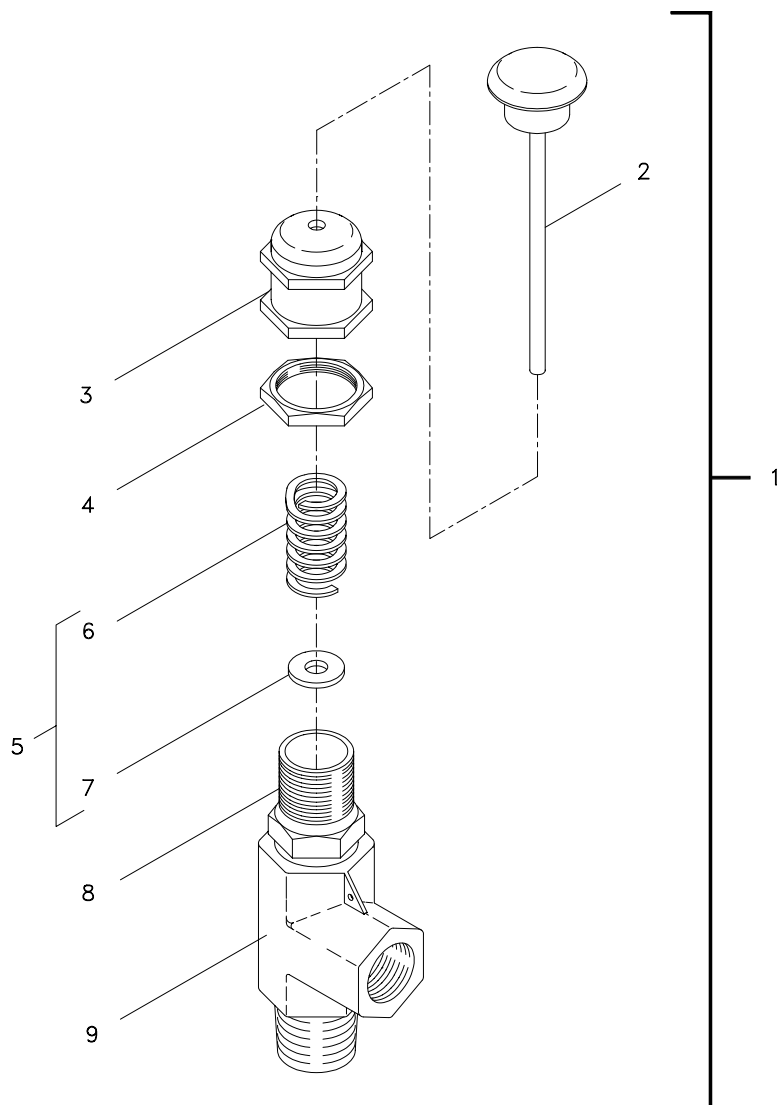
Item	Description	CAGE	NSN	Part No.	Qty.
1	High pressure regulator assembly	13669	---	44F5417T308	1
2	Valve body	13669	---	62615-1	1
3	Label	13669	---	60079	1
4	Back-up plate	13669	---	60214	1
5	Filter	13669	---	60213	1
6	O-ring (size 568-011)	13669	---	5200-030110	1
7	Back-up ring	13669	---	5476-10080	1
8	O-ring	13669	---	5200-020087	1
9	Washer	13669	---	7421	1
10	Spring	13669	---	3624	1
11	Valve	13669	---	62758-9	1
12	Seat	13669	---	62756-7	1
13	Seat retainer	13669	---	62757-9	1
14	Vent seat retainer	13669	---	62734-9	1
15	Vent valve	13669	---	62733-9	1
16	Spring	13669	---	62954	1
17	Valve seat	13669	---	6490	1
18	Sensor	13669	---	62735	1
19	O-ring	13669	---	5200-020307	2
20	O-ring	13669	5331-01-442-6954	5200-020327	1
21	O-ring	13669	---	5200-021437	1
22	Back-up sensor	13669	---	62618	1
23	Spring	13669	5360-01-267-3856	1051	1
24	Adjusting screw assembly	13669	---	40942	1
25	Setscrew	13669	5305-01-425-8298	5405-211686	1
26	Washer	13669	5310-00-009-7054	5425	1
27	Thrust bearing	13669	3120-01-263-0338	5424	1
28	Washer	13669	5310-00-009-7055	5426	1
29	Bonnet	13669	---	62616-1	1
30	Panel nut	13669	---	62634	1
31	Hand knob	13669	5355-01-383-9832	5397-6	1
32	Label (black)	13669	---	6320-1	1
33	Retaining ring	13669	5325-01-226-4469	5427	1
34	Hole plug	13669	5340-01-442-6961	5432	1
N/A	Repair kit, nonmetallic (soft goods only) (Includes 6-8, 12, 17, 19-21)	13669	---	389F7022	AR
N/A	Repair kit (Includes 4-8, 10-12, 15-17, 19-21)	13669	---	389F7023	AR

Note 1: Use the following torque values when reassembling regulator: Seat retainer (13) 100 in-lb, vent seat retainer (14) 50-60 in-lb, bonnet (29) 50 ft-lb, setscrew (25) 20-25 in-lb.

Note 2: See Figure 7-33 for attaching O-rings.

**Figure 7-34. Tescom HP Regulators (AHP-V201, AHP-V307) (Sheet 2 of 2)**

## SS500-HK-MMO-010



Item	Description	CAGE	NSN	Part No.	Qty.
1	Relief valve (see Note 1)	18034	4820-01-416-5651	SS-4R3A-1509	1
2	Manual override handle kit (see Note 2)	18034	4820-01-416-5650	SS-R3A-K5	1
3	Adjustment cap	18034	REF Item 1	REF Item 1	1
4	Locking nut	18034	REF Item 1	REF Item 1	1
5	Spring kit (see Note 3)	18034	5360-01-269-1968	177-R3A-K1-A	1
6	Blue spring	18034	REF Item 5	REF Item 5	1
7	Spring support disc	18034	REF Item 5	REF Item 5	1
8	Bonnet	18034	REF Item 1	REF Item 1	1
9	Valve body	18034	REF Item 1	REF Item 1	1
N/A	O-ring	81349	5330-01-422-9795	M83248/2-906	1

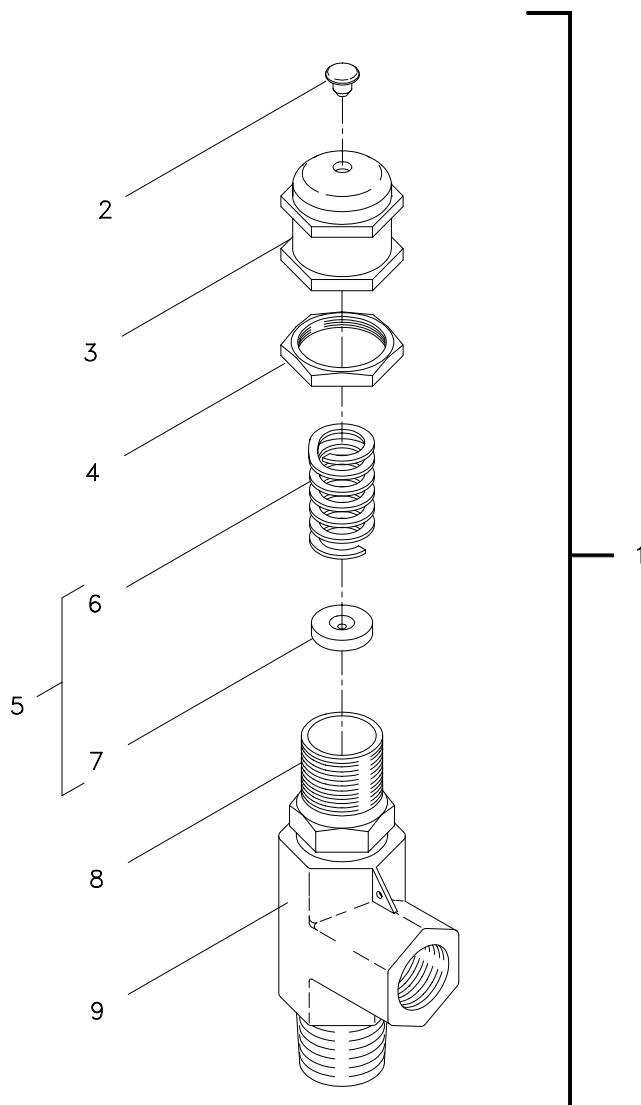
Note 1: Basic valve contains parts shown in Figure 7-36, except for spring kit as R3A valves are supplied without springs. To modify basic valve, order manual override handle kit (2) and spring kit (5).

Note 2: Contains handle, pull rod, spring support, and instructions.

Note 3: Contains blue spring (6) and spring support disc (7). Spring is color-coded for cracking pressure range of 50-350 psig. Other items in kit include label, lockwire/lead seal, and instructions.

**Figure 7-35. LP Relief Valve (ALP-V404)**

## SS500-HK-MMO-010



Item	Description	CAGE	NSN	Part No.	Qty.
1	Relief valve (see Notes 1, 3)	18034	4820-01-416-5651	SS-4R3A-1509	1
2	Cap plug	18034	REF Item 1	REF Item 1	1
3	Adjustment cap	18034	REF Item 1	REF Item 1	1
4	Locking nut	18034	REF Item 1	REF Item 1	1
5	Spring kit (see Note 2)	18034	5360-01-269-1969	177-R3A-K1-F	1
6	White spring	18034	REF Item 5	REF Item 5	1
7	Spring support disc	18034	REF Item 5	REF Item 5	1
8	Bonnet	18034	REF Item 1	REF Item 1	1
9	Valve body	18034	REF Item 1	REF Item 1	1
N/A	O-ring	81349	5330-01-422-9795	M83248/2-906	1

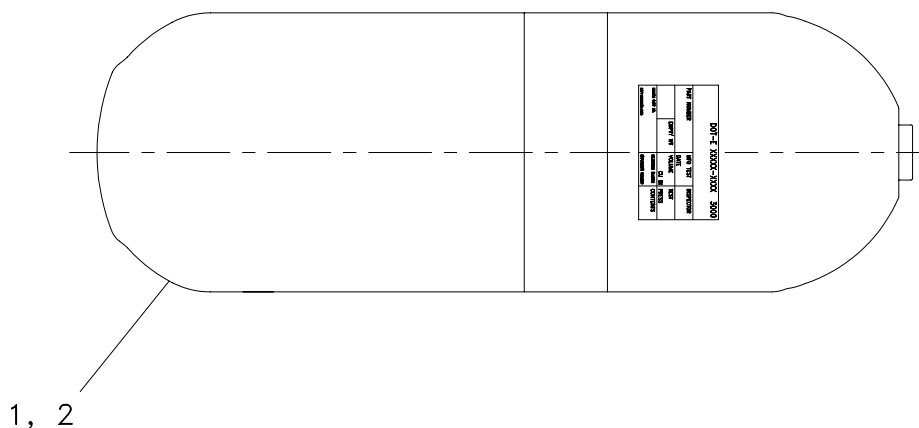
Note 1: Valve (1) and spring kit (5) must be ordered together as R3A valves are supplied without springs.

Note 2: Contains white spring (6) and spring support disc (7). Spring is color-coded for cracking pressure range of 3,000 to 4,000 psig. Other items in kit include label, lockwire/lead seal, and instructions.

Note 3: If desired, valve (1) can be modified for use as ALP-V404 using manual override handle kit and blue spring kit listed in Figure 7-35. See Chapter 6 for further details.

**Figure 7-36. HP Relief Valve (AHP-V603)**

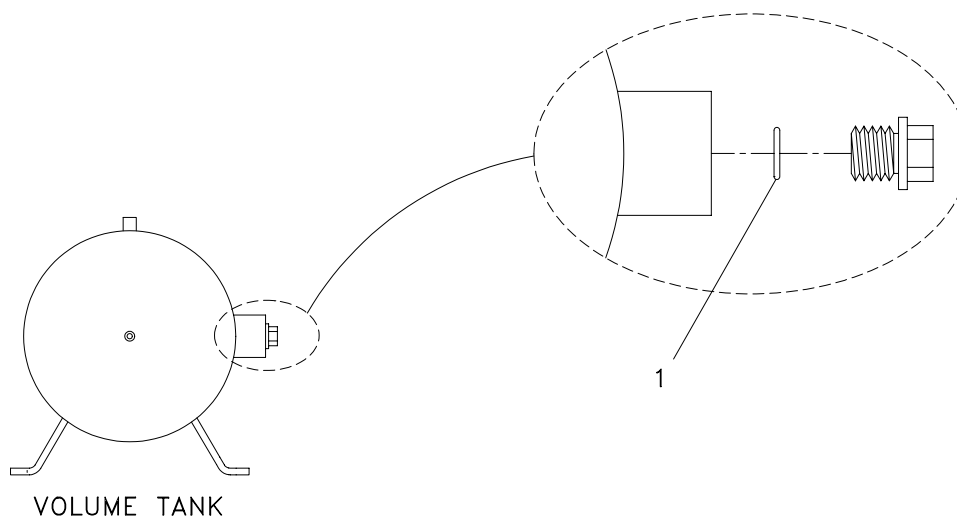
SS500-HK-MMO-010



Item	Description	CAGE	NSN	Part No.	Qty.
1	Flask, composite, Kevlar® Alternate PN	58943 59450	8120-01-429-5603 ---	1271027 T186A-001	1
2	Flask, composite, carbon fiber Alternate PN	58943 59450	--- ---	1272939 T200A-001	1

Note: Two manufacturers are listed for each type of flask—SCI (58943) and Luxfer (59450).

**Figure 7-37. Composite Flasks**



Item	Description	CAGE	NSN	Part No.	Qty.
1	O-ring (see note)	81349	5331-00-172-7189	M83248/2-924	2

Note: Volume tank contains two inspection port plugs with one O-ring each.

**Figure 7-38. Volume Tank Inspection Port Plug O-rings**

SS500-HK-MMO-010

Table 7-2. List of Manufacturers and Suppliers

CAGE Code	Manufacturer/Supplier Name, Address, and Telephone #	CAGE Code	Manufacturer/Supplier Name, Address, and Telephone #
02570	KAW VALVE & FITTING CO INC 4707 ROE PKWY SHAWNEE MISSION KS 66205 <b>Phone: 913-432-4884</b>	52159	3D INSTRUMENTS 15542 CHEMICAL LANE HUNTINGTON BEACH CA 92649-1505 <b>Phone: 714-894-5351</b>
03950	NAVAL INVENTORY CONTROL POINT MECHANICSBURG 5450 CARLISLE PIKE PO BOX 2020 MECHANICSBURG PA 17055-0788 <b>(No phone number listed)</b>	53711	NAVAL SEA SYSTEMS COMMAND 1333 ISAAC HULL AVENUE SE WASHINGTON NAVY YARD DC 20376 <b>Phone: 202-781-0000</b>
05LN3	WESTERN VALVE INC 114 E 46TH ST PO BOX 2446 AMARILLO TX 79118-7803 <b>Phone: 806-373-6811</b>	58943	STRUCTURAL COMPOSITES IND HARSCO GAS & FLUID CTRL GROUP 325 ENTERPRISE PL POMONA CA 91768-3268 <b>Phone: 909-594-7777</b>
12623	WHITEY CO 318 BISHOP RD CLEVELAND OH 44143-1533 <b>Phone: 440-473-1050</b>	59165	NORMAN FILTER CO 9850 S INDUSTRIAL DR BRIDGEVIEW IL 60455 <b>Phone: 800-207-6045</b>
13669	TESCOM CORP 12616 INDUSTRIAL BLVD ELK RIVER MN 55330 <b>Phone: 763-241-3288</b>	59379	ATLAS COPCO HOLYOKE INC 161 LOWER WESTFIELD RD HOLYOKE MA 01040 <b>Phone: 413-536-0600</b>
16166	WESTERN ENTERPRISES DIV OF SCOTT AND FETZER CO 33672 PIN OAK PKWY AVON LAKE OH 44012-2322 <b>Phone: 440-933-2171</b>	59450	SUPERFORM USA DIV OF LUXFER INC 6825 JURUPA AVE RIVERSIDE CA 92504 <b>Phone: 909-351-4100</b>
17238	PALL CORP 3643 STATE ROUTE 281 CORTLAND NY 13045-8902 <b>Phone: 607-753-6041</b>	71647	CONRADER R CO INC 1319 SASSAFRAS ST ERIE PA 16501 <b>Phone: 814-452-4631</b>
18034	NUPRO CO 4800 E 345TH ST WILLOUGHBY OH 44094-4607 <b>Phone: 440-473-1050</b>	73370	ALLIED AUTOMOTIVE ALLIED AFTERMARKET DIV 39 OLD RIDGEBERRY RD DANBURY CT 06810 <b>Phone: 203-830-7800</b>
39428	MCMaster-CARR SUPPLY CO 600 COUNTY LINE RD ELMHURST IL 60126 <b>Phone: 630-834-9600</b>	81349	MILITARY SPECIFICATIONS PROMULGATED BY MILITARY <b>(No address/phone number listed)</b>



SS500-HK-MMO-010

**Table 7-2. List of Manufacturers and Suppliers—Continued**

<b>CAGE Code</b>	<b>Manufacturer/Supplier Name, Address, and Telephone #</b>	<b>CAGE Code</b>	<b>Manufacturer/Supplier Name, Address, and Telephone #</b>
91816	CIRCLE SEAL CONTROLS INC 2301 WARDLOW CIRCLE CORONA CA 92880-2881 <b>Phone: 909-270-6236</b>	99565	CPV MANUFACTURING INC 851 N PRESTON ST PHILADELPHIA PA 19104-1598 <b>Phone: 215-386-6508</b>
97947	LISTER PETTER AMERICAS INC 815 E 56 HWY OLATHE KS 66061-4914 <b>Phone: 913-764-3512</b>		

## SS500-HK-MMO-010

## CHAPTER 8

### INSTALLATION

#### 8.1 INTRODUCTION

This chapter provides information and procedures for the initial inventory, inspection, testing, and storage of the Lightweight Dive System (LWDS) MK 3 Mod 0. The information in this chapter is arranged in the following sequence:

- Para. 8.2—Inventory . . . . . Page 8-1
- Para. 8.3—Inspection . . . . . Page 8-2
- Para. 8.4—Initial Operational Test . . . . . Page 8-4
- Para. 8.5—Storage Requirements . . . . . Page 8-4

Upon receipt of the LWDS, all components must be inventoried, inspected, and tested. The equipment may not be ready for immediate operational use and some components may require special preparation.

#### 8.2 INVENTORY

Conduct a visual inventory of the shipment to ensure that all items have been received. Verify that each item of equipment shipped appears on the packing lists included in the shipping documentation and that all serial numbers correspond to those on the packing lists. The initial LWDS shipment should consist of the items shown in Table 8-1.

**Table 8-1. LWDS MK 3 Mod 0 Initial Inventory**

Items	Total Quantity Supplied	Used in Configuration		
		1	2	3
<b>MAJOR ASSEMBLIES</b>				
Control Console Assembly	1	✓	✓	✓
Diesel-Compressor Assembly	1	✓		
Flask Rack Assemblies	4	1	min 4	min 5
Roof Rack Assembly	1	✓	✓	✓
Snorkel Assembly	1	✓		
Volume Tank Assembly	1	✓	✓	✓
<b>HOSES AND ADAPTERS</b>				
Deck Hose (H-101), Low Pressure (LP), 10-ft section, 1/2-in. Inside Diameter (ID) (Volume Tank to Control Console)	1	✓	✓	✓

## SS500-HK-MMO-010

Table 8-1. LWDS MK 3 Mod 0 Initial Inventory—Continued

Item	Total Quantity Supplied	Used in Configuration		
		1	2	3
<b>HOSES AND ADAPTERS—Continued</b>				
Deck Hose (H-102), High Pressure (HP), 30-ft section, 3/8-in. ID (Secondary HP Air Supply to Control Console) (Primary HP Air Supply to Volume Tank)	2	1 0	1 1	1 1
Deck Hose (H-104), LP, 50-ft sections, 1/2-in. ID (Diesel-Compressor to Volume Tank)	3	1-3		
Deck Hose (H-105), HP, user-defined length, 3/8-in. ID (Primary HP Air Supply to Primary HP Air Supply)	AR	N/A	AR	AR
Extension Hose, 20-ft section (Compressor Intake to Snorkel Assembly)	1	✓		
37° Flare to 37° Flare Union Adapters (AN 815-10K fittings)	2	AR	AR	AR
<b>ANCILLARY EQUIPMENT</b>				
Shipping Container	1	✓	✓	✓
Tool Kit (contains hand tachometer, scuba charging adapter, and packing adjustment tool)	1	✓	✓	✓
<b>DOCUMENTATION</b>				
Atlas Copco Parts List for L-Series Blocks (Compressor)	1	✓		
Lightweight Dive System (LWDS) MK 3 Mod 0 Technical Manual	1	✓	✓	✓
Lister Petter LT, LV Operators Handbook (Diesel Engine)	1	✓		
Lister Petter LT1, LV1 & 2 Parts List (Diesel Engine)	1	✓		

**8.3 INSPECTION**

Remove each item from its packing crate and perform a thorough inspection for any deviation from good manufacturing and packaging processes, such as incompleteness of assembly, faulty workmanship, rust, dirt, cracks, deterioration, and corrosion. Specific items to be inspected are indicated in the following paragraphs.

**8.3.1 DIESEL-COMPRESSOR ASSEMBLY.** The diesel-compressor assembly must be in good condition and suitable for use in accordance with U.S. Navy specifications. Inspect as follows:

- a. Check assembly for signs of deterioration or damage.
- b. Inspect hose connectors for chips, dents, scratches, or gouges.
- c. Check valves to ensure smooth and proper operation.

## SS500-HK-MMO-010

- d. Inspect for loose, damaged, or missing nuts, bolts, or screws.
- e. Check for broken gauges, indicators, or other damaged controls.

**8.3.2 SNORKEL ASSEMBLY.** The snorkel assembly must be in good condition and suitable for use in accordance with U.S. Navy specifications. Inspect as follows:

- a. Inspect hose and hose connectors for damage.
- b. Inspect intake filter for damage.

**8.3.3 VOLUME TANK ASSEMBLY.** The volume tank assembly must be in good condition and suitable for use in accordance with U.S. Navy specifications. Inspect as follows:

- a. Check assembly for signs of deterioration or damage.
- b. Inspect hose connectors for chips, dents, scratches, or gouges.
- c. Check valves to ensure smooth and proper operation.
- d. Inspect for loose, damaged, or missing nuts, bolts, or screws.
- e. Check for broken gauges, indicators, or other damaged controls.
- f. Check filters for damage.

**8.3.4 PRIMARY AND SECONDARY HP AIR FLASKS.** Procedures for inspecting the primary and secondary HP air flasks are located in Appendices C, D, and E of this manual. Appendix C presents internal inspection procedures for both Kevlar® and carbon fiber flasks, Appendix D covers external inspection of Kevlar® flasks, and Appendix E covers external inspection of carbon fiber flasks.

**8.3.5 CONTROL CONSOLE ASSEMBLY.** The control console assembly must be in good condition and suitable for use in accordance with U.S. Navy specifications. Inspect as follows:

- a. Check unit for signs of deterioration or damage.
- b. Inspect hose connectors for chips, dents, scratches, or gouges.
- c. Check valves to ensure smooth and proper operation.
- d. Inspect for loose, damaged, or missing, nuts, bolts, or screws.
- e. Check HP and LP pressure gauges for damage.
- f. Check depth gauges for damage.
- g. Ensure gauges have a current calibration date.
- h. Check unit for missing knobs and handles.
- i. Ensure console cover fits properly.

**8.3.6 INTERCONNECTING HOSES.** All interconnecting hoses must be in good condition and suitable for use in accordance with U.S. Navy specifications. Inspect as follows:

- a. Inspect hose connectors for chips, dents, scratches, or gouges.
- b. Inspect each hose for blisters or abrasions.
- c. Inspect each hose for cuts, cracks, or other damage.
- d. Inspect each hose for coupling pull-out.
- e. Ensure each hose has a current clean and hydrostatic test date.

## SS500-HK-MMO-010

**8.4 INITIAL OPERATIONAL TEST**

Prior to placing the LWDS into operation, test the system in the Configuration 1 layout using the applicable procedures specified in paragraphs 2.3.1 through 2.3.3. Then test the system in a Configuration 2 or 3 layout using the applicable procedures specified in paragraphs 2.3.1, 2.3.4, and 2.3.5.

**8.5 STORAGE REQUIREMENTS**

The LWDS is a Naval Sea Systems Command (NAVSEA) certified diving life support system; therefore, careful handling and storage of its components are required. Specific storage requirements for certain components are covered by Maintenance Requirement Cards (MRCs) in the Planned Maintenance System (PMS) package.

**8.5.1 SHORT-TERM STORAGE.** When the LWDS is to be stored for less than three months, use the postmission procedures in Table 2-18 / OP-7 to prepare the equipment for storage.

**8.5.2 LONG-TERM STORAGE.** If the LWDS is to be stored for a period of three months or more, prepare the LWDS for storage using the lay-up maintenance procedures in the following Maintenance Index Pages (MIPs) and MRCs:

- MIP 5921/170, MRC LU-1 (diesel engine)
- MIP 5921/170, MRC LU-2 (compressor)
- MIP 5921/171, MRC LU-1 (all other LWDS components)

The following periodic maintenance MRCs for inactive equipment inspection should also be performed during lay-up:

- MIP 5921/170, MRC PM-1 (diesel engine)
- MIP 5921/170, MRC PM-2 (compressor)

**8.5.3 STORAGE PRECAUTIONS.** General long-term storage precautions are listed below:

- Components shall not be stored in temperatures higher than 120°F (48.8°C) or lower than 0°F (-17°C).
- Components shall not be stored in direct sunlight due to the deteriorating effect of sunlight on rubber components.
- Components shall be dry and clean when stored.
- Flexible parts shall not be subjected to continuous distortion when stored.
- Ensure storage area is well ventilated.

# **APPENDIX A**

## **OPERATING AND EMERGENCY PROCEDURE CHECKLISTS FOR THE LIGHTWEIGHT DIVE SYSTEM (LWDS) MK 3 MOD 0**

This appendix contains Operating Procedure (OP) and Emergency Procedure (EP) checklists for the Lightweight Dive System (LWDS) MK 3 Mod 0. All figures referenced in the checklists are provided at the end of this appendix. Table A-1 provides an index identifying each procedure and figure by its number, title, and location within Appendix A.

THIS PAGE INTENTIONALLY LEFT BLANK

## SS500-HK-MMO-010

**Table A-1. Index of Appendix A Procedures and Figures**

<b>Procedure No.</b>	<b>Title</b>	<b>Page No.</b>
OP-1	Prepermission Procedures: Equipment Setup	A-3
OP-2.1	Pre-dive Start-Up: Configuration 1, Primary Air	A-9
OP-2.2	Pre-dive Start-Up: Configuration 1, Secondary Air	A-15
OP-2.3	Pre-dive Start-Up: Configurations 2 and 3, Primary Air	A-17
OP-2.4	Pre-dive Start-Up: Configurations 2 and 3, Secondary Air	A-21
OP-2M	Modified Start-Up Procedure	A-25
OP-3	Pre-dive/Post-dive: HP Flask Charging Procedure	A-29
OP-4	Pre-dive Start-Up: Diver Equipment	A-33
OP-5	During OPs: HP Flask Charging Procedure	A-35
OP-6	Post-dive Shutdown Procedures: Configurations 1, 2, and 3	A-37
OP-6M	Modified Shutdown Procedure: Configurations 1, 2, and 3	A-43
OP-7	Postmission Procedures: Configurations 1, 2, and 3	A-45
EP-1	Emergency Procedure: Loss of Primary Air	A-51
<b>Figure No.</b>	<b>Title</b>	<b>Page No.</b>
A-1	Lightweight Dive System (LWDS) MK 3 Mod 0, Configuration 1	A-52
A-2	LWDS MK 3 Mod 0 Schematic, Configuration 1	A-53
A-3	Lightweight Dive System (LWDS) MK 3 Mod 0, Configuration 2	A-54
A-4	LWDS MK 3 Mod 0 Schematic, Configuration 2	A-55
A-5	Lightweight Dive System (LWDS) MK 3 Mod 0, Configuration 3	A-56
A-6	LWDS MK 3 Mod 0 Schematic, Configuration 3	A-57
A-7	Lightweight Dive System (LWDS) MK 3 Mod 0, Multiple Stacks of Flask Racks, Configuration 3	A-58
A-8	LWDS MK 3 Mod 0 Schematic, Multiple Stacks of Flask Racks, Configuration 3	A-59
A-9	Fuel and Lubrication Chart	A-60



## SS500-HK-MMO-010

The checklists in this appendix correspond to the procedures in Chapter 2 of this manual and are designed to be reproduced for use in verifying the performance of the procedures. The following information covers the elements of each checklist and indicates what type of action, if any, is required:

- a. **DATE:** Checker fills in current date in acceptable format.
- b. **NOTE 1:** No action is required; contains a cross-reference to the corresponding procedure in Chapter 2 of this manual.
- c. **NOTE 2:** No immediate action is required; contains a reminder to record notes and deficiencies in REMARKS section at end of each OP or EP.
- d. **STEP:** No action is required; numbers in this column correspond to related steps in cross-reference provided in NOTE 1.
- e. **COMPONENT:** No action is required; column contains nomenclature for component(s) involved in each step.
- f. **DESCRIPTION:** No action is required; column contains valve and hose numbers (if applicable) of component(s) involved and any other information that may be helpful.
- g. **PROCEDURE:** Column describes actions to be performed by appropriate personnel. Checker verifies actions and fills in shaded boxes, if any, with required pressure information.
- h. **LOCATION:** No action is required; column contains name of assembly where referenced component is located.
- i. **CHECK:** Checker initials this column as each step is completed.
- j. **REF:** Checker places a mark in this column to indicate that a note has been included in REMARKS section at end of procedure.
- k. **REMARKS:** Checker uses this section to document any deficiencies or problems found during performance of a particular step. Checker should begin each note with configuration number (if more than one configuration is covered by OP) and step number involved.
- l. **Signature block:** Checker prints and signs name, and diving supervisor signs to verify that all actions have been performed and all deficiencies and problems have been noted.

## SS500-HK-MMO-010

OP-1 PREMISSION PROCEDURES: EQUIPMENT SETUP						
DATE: _____						
NOTE 1: See Table 2-7 for detailed procedures.						
NOTE 2: Record notes and deficiencies in section provided at the end of this operating procedure.						
STEP	COMPONENT	DESCRIPTION	PROCEDURE	LOCATION	CHECK	REF
NOTE 3: Perform steps 1 thru 3 in Part I for all configurations, then proceed to the appropriate section for the configuration being used.						
PART I - SYSTEM SETUP FOR CONFIGURATIONS 1, 2, AND 3						
<div style="border: 2px solid black; padding: 5px; width: fit-content; margin: 0 auto;"><b>WARNING</b></div> <p><b>Adequately position, stabilize, and secure all equipment prior to operation as movement during operation could result in equipment damage and injury or death to personnel.</b></p>						
1	Volume Tank Assembly	N/A	Remove cover. Assemble and secure.	Dive Station		
2	Control Console Assembly	N/A	Depress breather valves. Remove cover. Assemble and secure to platform.	Volume Tank Assembly		
3	Valves Regulator Gauge Isolation Gauge Isolation Drain Valve Drain Valve Drain Valve LP Air Out	AHP-V201 AHP-V202 ALP-V204 ALP-V205 ALP-V208 ALP-V209 ALP-V210	Ensure closed or unloaded.	Volume Tank Assembly		
	Gauge Isolation Supply Selector Diver Air (R) Diver Air (G) Diver Air (Y) Regulator Gauge Isolation Gauge Isolation Diver Depth (R) Diver Depth (G) Diver Depth (Y)	ALP-V301 ALP-V302 ALP-V304 ALP-V305 ALP-V306 AHP-V307 AHP-V309 ALP-V310 ALP-V312 ALP-V313 ALP-V314		Control Console Assembly		

## SS500-HK-MMO-010

OP-1 PREMISSION PROCEDURES: EQUIPMENT SETUP—Continued						
STEP	COMPONENT	DESCRIPTION	PROCEDURE	LOCATION	CHECK	REF
<b>PART I - SYSTEM SETUP FOR CONFIGURATIONS 1, 2, AND 3—Continued</b>						
3 Cont.	<u>Valves</u> Air Supply Next Rack Air Supply Out Gauge Isolation Air Supply This Rack Flask Valve Flask Valve Flask Valve	AHP-V501 AHP-V502 AHP-V503  AHP-V504 AHP-V505 AHP-V506 AHP-V507	Ensure closed or unloaded.	Secondary Flask Rack (Config. 1) or Primary/ Secondary Flask Rack (Config. 2 and 3)		
	Gauge Isolation Charge Inlet	AHP-V601 AHP-V604				
<b>PART II - CONFIGURATION 1 SETUP</b> (see Figures A-1 and A-2)						
<b>WARNINGS</b>						
<p><b>Do not place the compressor intake near the exhaust of any other equipment. The diesel exhaust silencer must be downwind of the snorkel assembly. Failure to observe this warning could result in injury or death to personnel breathing the compressed air.</b></p> <p><b>If the diesel-compressor assembly must operate in an enclosed space, provisions should be made for engine cooling, ventilation, noise, and diesel exhaust fume removal. Failure to comply with this warning may result in injury or death to personnel and damage to the equipment.</b></p>						
4	Diesel- Compressor Assembly	N/A	Place within 150 feet of dive station. Remove and store wheels.	Dive Station		
5	Snorkel Assembly	N/A	Position upwind of compressor exhaust. Connect air intake hose.	Dive Station		
6	Flask Rack Assembly (Require 1)	N/A	Position at desired location.	Dive Station		
7	Roof Rack Assembly	N/A	Place on top of flask rack assembly.	Secondary Flask Rack Assembly		
8	<u>Valves</u> LP Air Out Drain Valve Gauge Isolation	ALP-V401 ALP-V402 ALP-V405	Ensure closed or unloaded.	Diesel- Compressor Assembly		

## SS500-HK-MMO-010

OP-1 PREMISSION PROCEDURES: EQUIPMENT SETUP—Continued						
STEP	COMPONENT	DESCRIPTION	PROCEDURE	LOCATION	CHECK	REF
<b>PART II - CONFIGURATION 1 SETUP—Continued</b>						
<div style="border: 1px solid black; padding: 5px; width: fit-content; margin: 0 auto;">CAUTION</div> <p>Do not join more than three 50-foot sections of diesel-compressor to volume tank hose (H-104) together as it may cause the system to function improperly.</p>						
9	Deck Hose	H-104	Connect hose to compressor air outlet bulkhead connector.	Diesel-Compressor Assembly		
10	Deck Hose	H-101	Connect hose to volume tank <b>LP AIR OUT</b> bulkhead connector.	Volume Tank Assembly		
11	Flask Whips	AHP-V501 to AHP-V502 ————— AHP-V501 to <b>AHP OUT</b>	Disconnect whip from AHP-V502. Loosen whip at AHP-V501. Connect whip to roof rack <b>AHP OUT</b> . Tighten connectors.	Secondary Flask Rack Assembly / Roof Rack Assembly		
12	Deck Hose	H-102	Connect one end to AHP-V502.	Secondary Flask Rack Assembly		
13	Deck Hose	H-102	Connect free end to control console <b>SECONDARY SUPPLY</b> bulkhead connector.	Control Console Assembly		
<b>NOTE 4:</b> Proceed to OP-2.1, <i>Pre-dive Start-Up: Configuration 1, Primary Air.</i>						
<b>PART III - CONFIGURATION 2 SETUP</b> (see Figures A-3 and A-4)						
<b>NOTE 5:</b> Air calculations should always be performed to ensure adequate air is available for the dive.						
<b>NOTE 6:</b> Ensure steps 1 thru 3 in Part I have been performed prior to proceeding.						
4	Secondary Flask Rack Assembly (Require 1)	N/A	Position at desired location.	Dive Station		
<b>NOTE 7:</b> Additional stacks of flask rack assemblies may be added if more than three primary flask rack assemblies are required for the dive mission. Do not exceed a total height of four assemblies in each stack.						
5	Primary Flask Rack Assemblies (Require 3)	N/A	Stack on top of secondary flask rack assembly.	Secondary Flask Rack Assembly		

## SS500-HK-MMO-010

OP-1 PREMISSION PROCEDURES: EQUIPMENT SETUP—Continued						
STEP	COMPONENT	DESCRIPTION	PROCEDURE	LOCATION	CHECK	REF
<b>PART III - CONFIGURATION 2 SETUP—Continued</b>						
6	Roof Rack Assembly	N/A	Place on top of last stack of primary racks.	Primary Flask Rack Assemblies		
<b>NOTE 8:</b> Proceed to Part V of this OP and connect hoses in accordance with the procedure provided for the primary HP air supply.						
<b>PART IV - CONFIGURATION 3 SETUP (see Figures A-5 thru A-8)</b>						
<b>NOTE 9:</b> Air calculations should always be performed to ensure adequate air is available for the dive.						
<b>NOTE 10:</b> Ensure steps 1 thru 3 in Part I have been performed prior to proceeding.						
4	Secondary Flask Rack Assemblies (Require 2)	N/A	Stack at desired location.	Dive Station		
<b>NOTE 11:</b> Additional stacks of flask rack assemblies may be added if more than four primary flask rack assemblies are required for the dive mission. Do not exceed a total height of four assemblies in each stack.						
5	Primary Flask Rack Assemblies (Require 3)	N/A	Stack at desired location.	Dive Station		
6	Roof Rack Assembly	N/A	If single stack configuration, place roof rack as shown in Figures A-5 and A-6. If multiple stack configuration, place roof rack on last stack as shown in Figures A-7 and A-8.	Primary Flask Rack Assemblies		
<b>NOTE 12:</b> Proceed to Part V of this OP and connect hoses in accordance with the procedure provided for the primary HP air supply.						
<b>PART V - PRIMARY HP AIR SUPPLY HOSE CONNECTIONS FOR CONFIGURATIONS 2 AND 3</b>						
<b>NOTE 13:</b> If using the minimum configuration, skip the secondary steps designated by light shading. If using a multiple stack configuration, perform the actions in the shaded steps in addition to or in place of the minimum configuration requirement.						
1	Flask Whips	V501 to V502 (same rack)	Disconnect from AHP-V502 (all primary racks). Loosen at AHP-V501.	Primary Flask Rack Assembly		
	Flask Whip	(first stack, top rack)	Disconnect from AHP-V501. Bag and stow.	Primary Flask Rack Assembly		

## SS500-HK-MMO-010

OP-1 PREMISSION PROCEDURES: EQUIPMENT SETUP—Continued						
STEP	COMPONENT	DESCRIPTION	PROCEDURE	LOCATION	CHECK	REF
<b>PART V - PRIMARY HP AIR SUPPLY HOSE CONNECTIONS FOR CONFIGURATIONS 2 AND 3—Continued</b>						
2	Flask Whips	V501 to V502 (next rack) —— AHP-V501 to <b>AHP OUT</b>	Connect whips (all primary racks and roof rack). Tighten connectors.	Primary Flask Rack Assembly / Roof Rack Assembly		
	Deck Hose	H-105	Interconnect stacks.	Primary Flask Rack Assembly		
3	Deck Hose	H-102	Connect hose to lowest primary rack's AHP-V502 connector.	Primary Flask Rack Assembly		
	Deck Hose	H-102	Connect hose to AHP-V502 (first stack, bottom rack).	Primary Flask Rack Assembly		
4	Deck Hose	H-102	Connect hose to volume tank <b>HP IN</b> bulkhead connector.	Volume Tank Assembly		
5	Deck Hose	H-101	Connect hose to volume tank <b>LP AIR OUT</b> bulkhead connector.	Volume Tank Assembly		
<b>NOTE 14:</b> Proceed to Part VI or VII of this OP and connect hoses in accordance with the procedure provided for the secondary HP air supply.						
<b>PART VI - SECONDARY HP AIR SUPPLY HOSE CONNECTIONS FOR CONFIGURATION 2</b>						
<b>NOTE 15:</b> The following procedure is for use with Configuration 2 when using a single flask rack assembly for the secondary HP air supply. If using multiple flask rack assemblies, follow the procedure in Part VII.						
1	Flask Whip	AHP-V501 to AHP-V502 (same rack)	Disconnect from secondary rack AHP-V502. Cap/bag free end of whip.	Secondary Flask Rack Assembly		
2	Deck Hose	H-102	Connect one end to secondary rack AHP-V502.	Secondary Flask Rack Assembly		
3	Deck Hose	H-102	Connect free end to control console <b>SECONDARY SUPPLY</b> bulkhead connector.	Control Console Assembly		
<b>NOTE 16:</b> Proceed to OP-2.3, <i>Pre-dive Start-Up: Configurations 2 and 3, Primary Air.</i>						

SS500-HK-MMO-010

<b>OP-1 PREMISSION PROCEDURES: EQUIPMENT SETUP—Continued</b>						
STEP	COMPONENT	DESCRIPTION	PROCEDURE	LOCATION	CHECK	REF
<b>PART VII - SECONDARY HP AIR SUPPLY HOSE CONNECTIONS FOR CONFIGURATION 3</b>						
<b>NOTE 17:</b> The following procedure is for use with Configuration 3 or when using multiple flask rack assemblies for the secondary HP air supply. If using a single flask rack assembly, follow the procedure in Part VI.						
1	Flask Whips	AHP-V501 to AHP-V502 (same rack)	Disconnect from AHP-V502 (all secondary racks). Loosen at AHP-V501 (all but highest rack). Cap or bag whip on highest rack.	Secondary Flask Rack Assembly		
2	Flask Whips	AHP-V501 to AHP-V502 (next rack)	Starting with lowest secondary rack and working up, connect whip from AHP-V501 to AHP-V502 on next highest rack. Tighten connectors.	Secondary Flask Rack Assembly		
3	Deck Hose	H-102	Connect one end to secondary rack AHP-V502 (lowest rack).	Secondary Flask Rack Assembly		
4	Deck Hose	H-102	Connect free end to control console <b>SECONDARY SUPPLY</b> bulkhead connector.	Control Console Assembly		
<b>NOTE 18:</b> Proceed to OP-2.3, <i>Prediver Start-Up: Configurations 2 and 3, Primary Air.</i>						
<b>REMARKS:</b> (Using configuration and step number as a reference, list any deficiencies or problems found during performance of this procedure.)  <hr/> <hr/> <hr/> <hr/> <hr/> <hr/> 						
Performed By: _____ <div style="text-align: center;">Printed Name and Signature</div>						
Noted and Checked By: _____ <div style="text-align: center;">Diving Supervisor's Signature</div>						

## SS500-HK-MMO-010

OP-2.1 PRELIVE START-UP: CONFIGURATION 1, PRIMARY AIR						
DATE: _____						
NOTE 1: See Table 2-8 for detailed procedures.						
NOTE 2: Record notes and deficiencies in section provided at the end of this operating procedure.						
STEP	COMPONENT	DESCRIPTION	PROCEDURE	LOCATION	CHECK	REF
PART I - DIESEL-COMPRESSOR ASSEMBLY START-UP PROCEDURE						
<div style="border: 1px solid black; padding: 5px; display: inline-block; margin-bottom: 10px;"><b>WARNINGS</b></div> <p>Do not fill the fuel tank while it is mounted on the diesel-compressor assembly. The fuel tank shall be disconnected and moved away from the immediate vicinity of the diving equipment prior to refueling. Failure to observe this warning could result in a fuel spill, creating an immediate fire hazard and possibly causing contamination of the diving equipment, all of which could result in injury or death to personnel and damage to the equipment.</p> <p>The LWDS is designed to operate in ambient temperatures of 40°-100°F. When operating in temperatures below 40°F, the diesel-compressor assembly requires the use of special fuels and lubricants. Failure to use the prescribed diesel fuel and lubricating oils could result in injury or death to divers or support personnel and damage to the equipment.</p> <div style="border: 1px solid black; padding: 5px; display: inline-block; margin-bottom: 10px;"><b>CAUTIONS</b></div> <p style="text-align: center;">Use diesel fuel only. Ensure fuel tank vent is open.</p> <p>Fuel contamination can cause damage to the fuel injection system resulting in engine failure.</p>						
1	Diesel Engine Fuel Tank	N/A	Check fuel level. Refuel as required (Figure A-9).	Diesel-Compressor Assembly		
2	Diesel Engine Primer Bulb	N/A	Squeeze 8-10 times.	Diesel-Compressor Assembly		
3	Diesel Engine Dipstick	N/A	Check engine oil level. Add oil as required (Figure A-9); do not overfill.	Diesel-Compressor Assembly		
4	Compressor Sight Glass	N/A	Check compressor oil level. Add oil as required (Figure A-9). Fill to red dot; do not overfill.	Diesel-Compressor Assembly		
5	<b>GAUGE ISOLATION</b> Valve	ALP-V405	Ensure opened.	Diesel-Compressor Assembly		



## SS500-HK-MMO-010

OP-2.1 PRE-DIVE START-UP: CONFIGURATION 1, PRIMARY AIR—Continued						
STEP	COMPONENT	DESCRIPTION	PROCEDURE	LOCATION	CHECK	REF
<b>PART I - DIESEL-COMPRESSOR ASSEMBLY START-UP PROCEDURE—Continued</b>						
6	LP AIR OUT Valve	ALP-V401	Ensure closed.	Diesel-Compressor Assembly		
7	Pilot Valve	ALP-V403	Ensure unloaded.	Diesel-Compressor Assembly		
8	Diesel Engine Decompressor Lever	N/A	Ensure in <b>START</b> position.	Diesel-Compressor Assembly		
<div style="border: 1px solid black; padding: 2px; display: inline-block; margin-bottom: 10px;"><b>WARNING</b></div> <p><b>Allowing starter handle to rotate on the running shaft is dangerous and could result in injury or death to personnel.</b></p> <div style="border: 1px solid black; padding: 2px; display: inline-block; margin-bottom: 10px;"><b>CAUTION</b></div> <p>Never stop the diesel engine with the decompressors. Failure to comply with this caution may result in valve damage to engine.</p>						
9	Diesel Engine	N/A	Crank start. Run for 3-5 minutes unloaded.	Diesel-Compressor Assembly		
10	Pilot Valve	ALP-V403	Load compressor.	Diesel-Compressor Assembly		
11	<b>SUPPLY PRESSURE</b> Gauge	ALP-G406	Read and record pressure (should be 140 to 170 psig).  _____ psig	Diesel-Compressor Assembly		
<div style="border: 1px solid black; padding: 2px; display: inline-block; margin-bottom: 10px;"><b>WARNING</b></div> <p><b>For the following step, maintain a firm grip on the hose and point the free end away from personnel to avoid injury from flying debris.</b></p>						
12	LP AIR OUT Valve	ALP-V401	Prior to first dive only: Uncap H-104. Open valve. Blow out deck hose. Ensure full flow. Close valve.	Diesel-Compressor Assembly		

## SS500-HK-MMO-010

OP-2.1 PRE-DIVE START-UP: CONFIGURATION 1, PRIMARY AIR—Continued						
STEP	COMPONENT	DESCRIPTION	PROCEDURE	LOCATION	CHECK	REF
<b>PART II - VOLUME TANK ASSEMBLY START-UP PROCEDURE</b>						
13	Deck Hose	H-104	Prior to first dive only: Connect free end to volume tank <b>LP AIR IN</b> bulkhead connector.	Volume Tank Assembly		
14	<b>LP AIR OUT</b> Valve	ALP-V210	Ensure closed.	Volume Tank Assembly		
15	<b>GAUGE ISOLATION</b> Valve	ALP-V204	Open.	Volume Tank Assembly		
16	<b>LP AIR OUT</b> Valve	ALP-V401	Open slowly. Pressurize volume tank.	Diesel-Compressor Assembly		
17	<b>TANK PRESSURE</b> Gauge -or- <b>SUPPLY PRESSURE</b> Gauge	ALP-G212 -or- ALP-G406	Check compressor load and unload set points (145 ± 5 and 165 ± 5 psig, respectively).	Volume Tank Assembly / Diesel-Compressor Assembly		
18	Drain Valves	ALP-V205 ALP-V208 ALP-V209	Open. Allow moisture to drain. Close.	Volume Tank Assembly		
	Moisture Separator Drain Valve	ALP-V402	Open. Allow moisture to drain. Close.	Diesel-Compressor Assembly		
<div style="border: 1px solid black; padding: 5px; width: fit-content; margin: 0 auto;">CAUTION</div> <p>Never stop the diesel engine with the decompressors. Failure to comply with this caution may result in valve damage to engine.</p>						
19	Diesel Engine Stop/Run Cable	N/A	Pull up to stop diesel engine.	Diesel-Compressor Assembly		

## SS500-HK-MMO-010

OP-2.1 PRE-DIVE START-UP: CONFIGURATION 1, PRIMARY AIR—Continued						
STEP	COMPONENT	DESCRIPTION	PROCEDURE	LOCATION	CHECK	REF
<b>PART II - VOLUME TANK ASSEMBLY START-UP PROCEDURE—Continued</b>						
<div style="border: 1px solid black; padding: 5px; display: inline-block;"><b>WARNING</b></div> <p>If volume tank pressure drops during this procedure, volume tank check valve (ALP-V206) is faulty and must be replaced. Failure to comply with this warning may result in injury or death to personnel and damage to equipment.</p>						
20	Moisture Separator Drain Valve	ALP-V402	Open. Allow air to bleed from H-104. Close.	Diesel-Compressor Assembly		
<div style="border: 1px solid black; padding: 5px; display: inline-block;"><b>WARNING</b></div> <p>For the following step, maintain a firm grip on the hose and point the free end away from personnel to avoid injury from flying debris.</p>						
21	<b>LP AIR OUT</b> Valve	ALP-V210	Prior to first dive only: Uncap H-101. Open valve. Blow out deck hose. Ensure full flow. Close valve.	Volume Tank Assembly		
<b>PART III - CONTROL CONSOLE ASSEMBLY START-UP PROCEDURE</b>						
22	Deck Hose	H-101	Prior to first dive only: Connect hose to control console <b>PRIMARY SUPPLY</b> bulkhead connector.	Control Console Assembly		
23	<b>GAUGE ISOLATION</b> Valve	ALP-V301	Open.	Control Console Assembly		
24	<b>DIVER AIR / DIVER DEPTH</b> Bulkhead Connectors	N/A	Remove caps.	Control Console Assembly		
25	<b>LP AIR OUT</b> Valve	ALP-V210	Open slowly. Pressurize control console.	Volume Tank Assembly		
26	<b>SUPPLY SELECTOR</b> Valve	ALP-V302	Switch to <b>PRIMARY SUPPLY</b> .	Control Console Assembly		

## SS500-HK-MMO-010

OP-2.1 PRE-DIVE START-UP: CONFIGURATION 1, PRIMARY AIR—Continued						
STEP	COMPONENT	DESCRIPTION	PROCEDURE	LOCATION	CHECK	REF
<b>PART III - CONTROL CONSOLE ASSEMBLY START-UP PROCEDURE—Continued</b>						
27	<b>DIVER AIR</b> Valves	ALP-V304 ALP-V305 ALP-V306	Open. Confirm full flow. Close.	Control Console Assembly		
<div style="border: 1px solid black; padding: 5px; width: fit-content; margin: 0 auto;"><b>WARNING</b></div> <p><b>DO NOT FULLY OPEN DIVER DEPTH VALVES (ALP-V312, ALP-V313, and ALP-V314). Failure to comply will damage the diver depth gauges and may cause injury to personnel.</b></p>						
28	<b>DIVER DEPTH</b> Valves	ALP-V312 ALP-V313 ALP-V314	Open <b>slightly</b> . Confirm flow. Close.	Control Console Assembly		
<b>NOTE 3:</b> Proceed to OP-2.2, <i>Pre-dive Start-Up: Configuration 1, Secondary Air.</i>						

**REMARKS:** (Using step number as a reference, list any deficiencies or problems found during performance of this procedure.)

---



---



---



---



---



---



---



---



---



---

Performed By: \_\_\_\_\_  
Printed Name and Signature

Noted and Checked By: \_\_\_\_\_  
Diving Supervisor's Signature

THIS PAGE INTENTIONALLY LEFT BLANK

## SS500-HK-MMO-010

OP-2.2 PRE-DIVE START-UP: CONFIGURATION 1, SECONDARY AIR						
DATE: _____						
NOTE 1: See Table 2-9 for detailed procedures.						
NOTE 2: Record notes and deficiencies in section provided at the end of this operating procedure.						
STEP	COMPONENT	DESCRIPTION	PROCEDURE	LOCATION	CHECK	REF
NOTE 3: If diving supervisor determines that flasks need to be charged before, during, or after performance of this procedure, refer to OP-3, <i>Pre-dive/Post-dive: HP Flask Charging Procedure</i> . Ensure that valves are returned to previous settings prior to continuing this procedure or beginning the next procedure.						
1	<b>GAUGE ISOLATION Valve</b>	AHP-V503	Open.	Secondary Flask Rack Assembly		
2	<b>AIR SUPPLY THIS RACK Valve</b>	AHP-V504	Open.	Secondary Flask Rack Assembly		
3	<b>AIR SUPPLY NEXT RACK Valve</b>	AHP-V501	Open.	Secondary Flask Rack Assembly		
4	<b>GAUGE ISOLATION Valve</b>	AHP-V601	Open.	Roof Rack Assembly		
5	Flask Shutoff Valves	AHP-V505 AHP-V506 AHP-V507	Open.	Secondary Flask Rack Assembly		
6	<b>MANIFOLD PRESSURE Gauge</b>	AHP-G508	Record pressure. Compare reading with AHP-G602.  _____ psig	Secondary Flask Rack Assembly		
7	<b>GAUGE ISOLATION Valve</b>	AHP-V309	Open.	Control Console Assembly		
8	<b>GAUGE ISOLATION Valve</b>	ALP-V310	Open.	Control Console Assembly		
9	Manual Adjust Regulator	AHP-V307	Ensure unloaded.	Control Console Assembly		
10	<b>AIR SUPPLY OUT Valve</b>	AHP-V502	Open.	Secondary Flask Rack Assembly		

## SS500-HK-MMO-010

OP-2.2 PRELIVE START-UP: CONFIGURATION 1, SECONDARY AIR—Continued						
STEP	COMPONENT	DESCRIPTION	PROCEDURE	LOCATION	CHECK	REF
11	<b>HIGH PRESSURE IN Gauge</b>	AHP-G316	Record pressure. _____ psig	Control Console Assembly		
<b>NOTE 4: Diving Supervisor:</b> Determine minimum manifold pressure.						
12	Manual Adjust Regulator	AHP-V307	Increase low pressure out as directed by diving supervisor.	Control Console Assembly		
13	<b>SUPPLY SELECTOR Valve</b>	ALP-V302	Switch to <b>SECONDARY SUPPLY</b> .	Control Console Assembly		
14	<b>DIVER AIR Valves and Bulkhead Connectors</b>	ALP-V304 ALP-V305 ALP-V306	Ensure bulkhead connectors are uncapped. Open valves. Confirm full flow. Close valves.	Control Console Assembly		
15	<b>SUPPLY SELECTOR Valve</b>	ALP-V302	Switch to <b>CLOSE</b> .	Control Console Assembly		
<b>NOTE 5:</b> Proceed to OP-4, <i>Prelive Start-Up: Diver Equipment</i> .						

**REMARKS:** (Using step number as a reference, list any deficiencies or problems found during performance of this procedure.)

---



---



---



---



---



---



---

Performed By: \_\_\_\_\_  
Printed Name and Signature

Noted and Checked By: \_\_\_\_\_  
Diving Supervisor's Signature

## SS500-HK-MMO-010

OP-2.3 PRE-DIVE START-UP: CONFIGURATIONS 2 AND 3, PRIMARY AIR						
DATE: _____						
NOTE 1: See Table 2-10 for detailed procedures.						
NOTE 2: Record notes and deficiencies in section provided at the end of this operating procedure.						
STEP	COMPONENT	DESCRIPTION	PROCEDURE	LOCATION	CHECK	REF
NOTE 3: Air calculations should always be performed to ensure adequate air is available for the dive.						
NOTE 4: If diving supervisor determines that flasks need to be charged before, during, or after performance of this procedure, refer to OP-3, <i>Pre-dive/Post-dive: HP Flask Charging Procedure</i> . Ensure that valves are returned to previous settings prior to continuing this procedure or beginning the next procedure.						
NOTE 5: If using the minimum configuration, skip the secondary steps designated by light shading. If using a multiple stack configuration, perform the actions in the shaded steps in addition to or in place of the minimum configuration requirement.						
PART I - PRIMARY HP AIR SUPPLY START-UP PROCEDURE						
1	GAUGE ISOLATION Valves	AHP-V503	Open (all primary racks).	Primary Flask Rack Assembly		
		AHP-V601	Open.	Roof Rack Assembly		
2	AIR SUPPLY THIS RACK Valves	AHP-V504	Open (all primary racks).	Primary Flask Rack Assembly		
3	Flask Shutoff Valves	AHP-V505 AHP-V506 AHP-V507	Open (all primary racks).	Primary Flask Rack Assembly		
NOTE 6: Notify the diving supervisor if primary flask rack pressure in step 4 is less than 3,000 psig.						
4	MANIFOLD PRESSURE Gauges	AHP-G508	Record rack pressure (all primary racks).	Primary Flask Rack Assembly		
			Rack # _____ psig			
			Rack # _____ psig			
			Rack # _____ psig			
			Rack # _____ psig			
			Rack # _____ psig			
			Rack # _____ psig			
			Rack # _____ psig			
5	AIR SUPPLY NEXT RACK Valves	AHP-V501	Open (all primary racks).	Primary Flask Rack Assembly		
NOTE 7: Do not open AIR SUPPLY OUT valve (AHP-V502) on lowest primary rack. In multiple stack configurations, do not open AHP-V502 on bottom rack of first stack.						



## SS500-HK-MMO-010

OP-2.3 PRELIVE START-UP: CONFIGURATIONS 2 AND 3, PRIMARY AIR—Continued						
STEP	COMPONENT	DESCRIPTION	PROCEDURE	LOCATION	CHECK	REF
<b>PART I - PRIMARY HP AIR SUPPLY START-UP PROCEDURE—Continued</b>						
6	<b>AIR SUPPLY OUT</b> Valves	AHP-V502	Open (all primary racks except for lowest rack).	Primary Flask Rack Assembly		
7	Pressure Gauge	AHP-G602	Record system pressure. _____ psig	Roof Rack Assembly		
<b>NOTE 8: Diving Supervisor:</b> Ensure there is adequate primary flask rack pressure to accomplish mission.						
<b>PART II - VOLUME TANK ASSEMBLY START-UP PROCEDURE</b>						
8	<b>GAUGE ISOLATION</b> Valve	AHP-V202	Open.	Volume Tank Assembly		
9	<b>GAUGE ISOLATION</b> Valve	ALP-V204	Open.	Volume Tank Assembly		
10	Manual Adjust Regulator	AHP-V201	Ensure unloaded.	Volume Tank Assembly		
11	<b>LP AIR OUT</b> Valve	ALP-V210	Ensure closed.	Volume Tank Assembly		
12	<b>AIR SUPPLY OUT</b> Valve	AHP-V502	Open (lowest primary rack).	Primary Flask Rack Assembly		
	<b>AIR SUPPLY OUT</b> Valve	AHP-V502	Open (first stack, bottom rack).	Primary Flask Rack Assembly		
13	<b>HP SUPPLY PRESSURE</b> Gauge	AHP-G211	Record pressure.	Volume Tank Assembly		
			_____ psig			
<b>NOTE 9: Diving Supervisor:</b> Determine minimum manifold pressure.						
14	Manual Adjust Regulator	AHP-V201	Increase low pressure out as directed by diving supervisor.	Volume Tank Assembly		
15	Drain Valve	ALP-V208	Open. Drain moisture. Close.	Volume Tank Assembly		

## SS500-HK-MMO-010

OP-2.3 PRE-DIVE START-UP: CONFIGURATIONS 2 AND 3, PRIMARY AIR—Continued						
STEP	COMPONENT	DESCRIPTION	PROCEDURE	LOCATION	CHECK	REF
<b>PART II - VOLUME TANK ASSEMBLY START-UP PROCEDURE—Continued</b>						
<div style="border: 1px solid black; padding: 5px; display: inline-block; margin-bottom: 10px;"><b>WARNING</b></div> <p>For the following step, maintain a firm grip on the hose and point the free end away from personnel to avoid injury from flying debris.</p>						
16	LP AIR OUT Valve	ALP-V210	Prior to first dive only: Uncap H-101. Open valve. Blow out deck hose. Ensure full flow. Close valve.	Volume Tank Assembly		
17	Deck Hose	H-101	Prior to first dive only: Connect free end to control console <b>PRIMARY SUPPLY</b> bulkhead connector.	Control Console Assembly		
<b>PART III - CONTROL CONSOLE ASSEMBLY START-UP PROCEDURE</b>						
18	GAUGE ISOLATION Valve	ALP-V301	Open.	Control Console Assembly		
19	DIVER AIR / DIVER DEPTH Bulkhead Connectors	N/A	Remove caps.	Control Console Assembly		
20	LP AIR OUT Valve	ALP-V210	Open slowly. Pressurize control console.	Volume Tank Assembly		
21	LOW PRESSURE SUPPLY Gauge	ALP-G315	Record pressure.  _____ psig	Control Console Assembly		
22	SUPPLY SELECTOR Valve	ALP-V302	Switch to <b>PRIMARY SUPPLY</b> .	Control Console Assembly		
23	DIVER AIR Valves	ALP-V304 ALP-V305 ALP-V306	Open. Confirm full flow. Close.	Control Console Assembly		



## SS500-HK-MMO-010

OP-2.4 PRE-DIVE START-UP: CONFIGURATIONS 2 AND 3, SECONDARY AIR						
DATE: _____						
NOTE 1: See Table 2-11 for detailed procedures.						
NOTE 2: Record notes and deficiencies in section provided at the end of this operating procedure.						
STEP	COMPONENT	DESCRIPTION	PROCEDURE	LOCATION	CHECK	REF
NOTE 3: Air calculations should always be performed to ensure adequate air is available for the dive.						
NOTE 4: If diving supervisor determines that flasks need to be charged before, during, or after performance of this procedure, perform OP-3, <i>Pre-dive/Post-dive: HP Flask Charging Procedure</i> . Ensure that valves are returned to previous settings prior to continuing this procedure or beginning the next procedure.						
PART I - CONFIGURATION 2: SECONDARY HP AIR SUPPLY AND CONTROL CONSOLE ASSEMBLY START-UP PROCEDURE						
1	GAUGE ISOLATION Valve	AHP-V503	Open.	Secondary Flask Rack Assembly		
2	AIR SUPPLY THIS RACK Valve	AHP-V504	Open.	Secondary Flask Rack Assembly		
3	Flask Shutoff Valves	AHP-V505 AHP-V506 AHP-V507	Open.	Secondary Flask Rack Assembly		
4	MANIFOLD PRESSURE Gauge	AHP-G508	Record pressure.	Secondary Flask Rack Assembly		
			_____ psig			
5	GAUGE ISOLATION Valve	AHP-V309	Open.	Control Console Assembly		
6	GAUGE ISOLATION Valve	ALP-V310	Open.	Control Console Assembly		
7	Manual Adjust Regulator	AHP-V307	Ensure unloaded.	Control Console Assembly		
8	AIR SUPPLY OUT Valve	AHP-V502	Open.	Secondary Flask Rack Assembly		
9	HIGH PRESSURE IN Gauge	AHP-G316	Record pressure.	Control Console Assembly		
			_____ psig			
NOTE 5: <b>Diving Supervisor:</b> For the following step, refer to the minimum manifold pressure established in OP-2.3.						

## SS500-HK-MMO-010

OP-2.4 PREDIVES START-UP: CONFIGURATIONS 2 AND 3, SECONDARY AIR—Continued						
STEP	COMPONENT	DESCRIPTION	PROCEDURE	LOCATION	CHECK	REF
<b>PART I - CONFIGURATION 2: SECONDARY HP AIR SUPPLY AND CONTROL CONSOLE ASSEMBLY START-UP PROCEDURE—Continued</b>						
10	Manual Adjust Regulator	AHP-V307	Increase low pressure out as directed by diving supervisor.	Control Console Assembly		
11	<b>SUPPLY SELECTOR</b> Valve	ALP-V302	Switch to <b>SECONDARY SUPPLY</b> .	Control Console Assembly		
12	<b>DIVER AIR</b> Valves and Bulkhead Connectors	ALP-V304 ALP-V305 ALP-V306	Ensure bulkhead connectors are uncapped. Open valves. Confirm full flow. Close valves.	Control Console Assembly		
13	<b>SUPPLY SELECTOR</b> Valve	ALP-V302	Switch to <b>CLOSE</b> .	Control Console Assembly		
<b>NOTE 6:</b> Proceed to OP-4, <i>Predives Start-Up: Diver Equipment</i> .						
<b>PART II - CONFIGURATION 3: SECONDARY HP AIR SUPPLY AND CONTROL CONSOLE ASSEMBLY START-UP PROCEDURE</b>						
1	<b>GAUGE ISOLATION</b> Valves	AHP-V503	Open (all secondary racks).	Secondary Flask Rack Assembly		
2	<b>AIR SUPPLY THIS RACK</b> Valves	AHP-V504	Open (all secondary racks).	Secondary Flask Rack Assembly		
3	Flask Shutoff Valves	AHP-V505 AHP-V506 AHP-V507	Open (all secondary racks).	Secondary Flask Rack Assembly		
4	<b>MANIFOLD PRESSURE</b> Gauge(s)	AHP-G508	Record secondary flask rack pressure.  Rack # _____ psig Rack # _____ psig Rack # _____ psig Rack # _____ psig	Secondary Flask Rack Assembly		
5	<b>GAUGE ISOLATION</b> Valve	AHP-V309	Open.	Control Console Assembly		
6	<b>GAUGE ISOLATION</b> Valve	ALP-V310	Open.	Control Console Assembly		

## SS500-HK-MMO-010

OP-2.4 PRE-DIVE START-UP: CONFIGURATIONS 2 AND 3, SECONDARY AIR—Continued						
STEP	COMPONENT	DESCRIPTION	PROCEDURE	LOCATION	CHECK	REF
<b>PART II - CONFIGURATION 3: SECONDARY HP AIR SUPPLY AND CONTROL CONSOLE ASSEMBLY START-UP PROCEDURE—Continued</b>						
7	Manual Adjust Regulator	AHP-V307	Ensure unloaded.	Control Console Assembly		
8	<b>AIR SUPPLY OUT</b> Valve	AHP-V502	Open (all secondary racks).	Secondary Flask Rack Assembly		
9	<b>HIGH PRESSURE IN</b> Gauge	AHP-G316	Record pressure. _____ psig	Control Console Assembly		
<b>NOTE 7: Diving Supervisor:</b> For the following step, refer to the minimum manifold pressure established in OP-2.3.						
10	Manual Adjust Regulator	AHP-V307	Increase low pressure out as directed by diving supervisor.	Control Console Assembly		
11	<b>SUPPLY SELECTOR</b> Valve	ALP-V302	Switch to <b>SECONDARY SUPPLY</b> .	Control Console Assembly		
12	<b>DIVER AIR</b> Valves and Bulkhead Connectors	ALP-V304 ALP-V305 ALP-V306	Ensure bulkhead connectors are uncapped. Open valves. Confirm full flow. Close valves.	Control Console Assembly		
13	<b>SUPPLY SELECTOR</b> Valve	ALP-V302	Switch to <b>CLOSE</b> .	Control Console Assembly		
<b>NOTE 8:</b> Proceed to OP-4, <i>Pre-dive Start-Up: Diver Equipment</i> .						
<b>REMARKS:</b> (Using configuration and step number as a reference, list any deficiencies or problems found during performance of this procedure.)						



## SS500-HK-MMO-010

<b>OP-2M MODIFIED START-UP PROCEDURE</b>						
<b>DATE:</b> _____						
<b>NOTE 1:</b> See Table 2-12 for detailed procedures. This OP may be used only if the modified shutdown procedure in OP-6M was performed during the last shutdown.						
<b>NOTE 2:</b> Record notes and deficiencies in section provided at the end of this operating procedure.						
<b>STEP</b>	<b>COMPONENT</b>	<b>DESCRIPTION</b>	<b>PROCEDURE</b>	<b>LOCATION</b>	<b>CHECK</b>	<b>REF</b>
<b>NOTE 3:</b> If flasks require charging immediately before, during, or after performance of this procedure, refer to OP-3, <i>Pre-dive/Post-dive: HP Flask Charging Procedure</i> . Ensure valves are returned to previous settings prior to continuing this procedure or beginning the next one.						
1	<b>AIR SUPPLY OUT</b> Valve	AHP-V502	Open as required (all primary and secondary racks).	Primary / Secondary Flask Rack Assemblies		
2	Diesel-Compressor Assembly	N/A	Configuration 1 only: Perform steps 2a thru 2k.	Diesel-Compressor Assembly		
<div style="border: 1px solid black; padding: 5px; width: fit-content; margin: 0 auto;"><b>WARNINGS</b></div> <p><b>Do not fill the fuel tank while it is mounted on the diesel-compressor assembly. The fuel tank shall be disconnected and moved away from the immediate vicinity of the diving equipment prior to refueling. Failure to observe this warning could result in a fuel spill, creating an immediate fire hazard and possibly causing contamination of the diving equipment, all of which could result in injury or death to personnel and damage to the equipment.</b></p> <p><b>The LWDS is designed to operate in ambient temperatures of 40°-100°F. When operating in temperatures below 40°F, the diesel-compressor assembly requires the use of special fuels and lubricants. Failure to use the prescribed diesel fuel and lubricating oils could result in injury or death to divers or support personnel and damage to the equipment.</b></p> <div style="border: 1px solid black; padding: 5px; width: fit-content; margin: 0 auto;"><b>CAUTIONS</b></div> <p style="text-align: center;">Use diesel fuel only. Ensure fuel tank vent is open.</p> <p style="text-align: center;">Fuel contamination can cause damage to the fuel injection system resulting in engine failure.</p>						
2a	Diesel Engine Fuel Tank	N/A	Check fuel level. Refuel as required (Figure A-9).	Diesel-Compressor Assembly		
2b	Diesel Engine Primer Bulb	N/A	Squeeze 8-10 times.	Diesel-Compressor Assembly		



## SS500-HK-MMO-010

OP-2M MODIFIED START-UP PROCEDURE—Continued						
STEP	COMPONENT	DESCRIPTION	PROCEDURE	LOCATION	CHECK	REF
2c	Diesel Engine Dipstick	N/A	Check engine oil level. Add oil as required (Figure A-9); do not overfill.	Diesel-Compressor Assembly		
2d	Compressor Sight Glass	N/A	Check compressor oil level. Add oil as required (Figure A-9). Fill to red dot; do not overfill.	Diesel-Compressor Assembly		
2e	<b>LP AIR OUT</b> Valve	ALP-V401	Ensure closed.	Diesel-Compressor Assembly		
2f	Pilot Valve	ALP-V403	Ensure unloaded.	Diesel-Compressor Assembly		
2g	Diesel Engine Decompressor Lever	N/A	Ensure in <b>START</b> position.	Diesel-Compressor Assembly		
<div style="border: 1px solid black; padding: 5px; width: fit-content; margin: 0 auto 10px auto;"><b>WARNING</b></div> <p><b>Allowing starter handle to rotate on the running shaft is dangerous and could result in injury or death to personnel.</b></p> <div style="border: 1px solid black; padding: 5px; width: fit-content; margin: 0 auto 10px auto;"><b>CAUTION</b></div> <p>Never stop the diesel engine with the decompressors. Failure to comply with this caution may result in valve damage to engine.</p>						
2h	Diesel Engine	N/A	Crank start. Run for 3-5 minutes unloaded.	Diesel-Compressor Assembly		
2i	Pilot Valve	ALP-V403	Load compressor.	Diesel-Compressor Assembly		
2j	<b>SUPPLY PRESSURE</b> Gauge	ALP-G406	Read and record pressure (should be 140 to 170 psig).  _____ psig	Diesel-Compressor Assembly		
2k	<b>LP AIR OUT</b> Valve	ALP-V401	Open fully.	Diesel-Compressor Assembly		

## SS500-HK-MMO-010

OP-2M MODIFIED START-UP PROCEDURE—Continued						
STEP	COMPONENT	DESCRIPTION	PROCEDURE	LOCATION	CHECK	REF
3	Manual Adjust Regulator	AHP-V201	Configurations 2 and 3 only: Load in accordance with minimum manifold pressure.	Volume Tank Assembly		
4	<b>LP AIR OUT</b> Valve	ALP-V210	Open.	Volume Tank Assembly		
5	Manual Adjust Regulator	AHP-V307	Load in accordance with minimum manifold pressure.	Control Console Assembly		
6	<b>SUPPLY SELECTOR</b> Valve	ALP-V302	Switch to <b>SECONDARY SUPPLY</b> .	Control Console Assembly		
<div style="border: 1px solid black; padding: 2px; display: inline-block; margin: 0 auto;"><b>WARNING</b></div> <p><b>For the following step, maintain a firm grip on the hose and point the free end away from personnel to avoid injury from flying debris.</b></p>						
7	<b>DIVER AIR</b> Valves	ALP-V304 ALP-V305 ALP-V306	Open slowly. Purge hoses. Close.	Control Console Assembly		
8	<b>SUPPLY SELECTOR</b> Valve	ALP-V302	Switch to <b>PRIMARY SUPPLY</b> .	Control Console Assembly		
<div style="border: 1px solid black; padding: 2px; display: inline-block; margin: 0 auto;"><b>WARNING</b></div> <p><b>For the following step, maintain a firm grip on the hose and point the free end away from personnel to avoid injury from flying debris.</b></p>						
9	<b>DIVER AIR</b> Valves	ALP-V304 ALP-V305 ALP-V306	Open slowly. Purge hoses. Close.	Control Console Assembly		
<b>NOTE 4:</b> Proceed to OP-4, <i>Pre-dive Start-Up: Diver Equipment</i> .						
<b>REMARKS:</b> (Using step number as a reference, list any deficiencies or problems found during performance of this procedure.)						



## SS500-HK-MMO-010

OP-3 PREDIVE/POSTDIVE: HP FLASK CHARGING PROCEDURE						
DATE: _____						
<b>NOTE 1:</b> See Table 2-13 for detailed procedures.						
<b>NOTE 2:</b> Record notes and deficiencies in section provided at the end of this operating procedure.						
STEP	COMPONENT	DESCRIPTION	PROCEDURE	LOCATION	CHECK	REF
<b>NOTE 3:</b> The following flask charging procedure applies to all configurations. Flask racks should be charged only as required.						
<b>NOTE 4:</b> The flask charging procedure involves the following LWDS equipment, as required: Configuration 1—1 secondary flask rack assembly, 1 roof rack assembly Configuration 2—1 secondary flask rack assembly, minimum of 3 primary flask rack assemblies, 1 roof rack assembly Configuration 3—minimum of 2 secondary and 3 primary flask rack assemblies, 1 roof rack assembly						
<b>NOTE 5:</b> If charging without a roof rack assembly, ensure charging whip has a relief valve set at 3,300 psig.						
<b>NOTE 6:</b> Perform pre-steps A thru C only if secondary flask rack in Configuration 2 requires charging; otherwise, proceed to step 1.						
A	Primary Deck Hose	H-102	Ensure depressurized then disconnect from AHP-V502 on lowest primary rack (first stack, bottom rack if multiple stacks). Cap hose.	Primary Flask Rack Assembly		
B	Flask Whip	AHP-V501 (secondary) to AHP-V502 (primary)	Loosen at AHP-V501 (secondary rack). Unbag whip and connect to AHP-V502 (lowest primary rack). Tighten connectors.	Primary / Secondary Flask Rack Assemblies		
C	Secondary Deck Hose	H-102	Ensure depressurized then disconnect from AHP-V502 (secondary rack). Cap valve and hose.	Secondary Flask Rack Assembly		
<b>NOTE 7:</b> Ensure all HP flasks and components have valid hydrostatic test dates.						
<b>NOTE 8:</b> Perform the following procedure only on the racks that are to be charged.						
1	HP Flask Rack Valves	AHP-V501 AHP-V502 AHP-V503 AHP-V504 AHP-V505 AHP-V506 AHP-V507	Ensure closed (all primary and secondary racks).	Primary / Secondary Flask Rack Assemblies		
<b>NOTE 9:</b> Ensure flask whips are properly connected between racks (see Table 2-13 for details). For multiple stacks only: Ensure stacks are interconnected (see Table 2-7, Part V, Step 2 for details).						
2	<b>GAUGE ISOLATION</b> Valves	AHP-V503	Open (all primary and secondary racks).	Primary / Secondary Flask Rack Assemblies		

## SS500-HK-MMO-010

OP-3 PRE-DIVE/POST-DIVE: HP FLASK CHARGING PROCEDURE—Continued						
STEP	COMPONENT	DESCRIPTION	PROCEDURE	LOCATION	CHECK	REF
3	<b>GAUGE ISOLATION</b> Valve	AHP-V601	Open.	Roof Rack Assembly		
<div style="border: 1px solid black; padding: 5px; display: inline-block; margin-bottom: 10px;"><b>WARNINGS</b></div> <p><b>Use only Authorized for Navy Use (ANU) approved HP compressors with moisture separators and filtration for charging LWDS HP air flasks. Refer to <i>Diving Equipment Authorized for U.S. Navy Use (ANU)</i> list for approved HP compressors.</b></p> <p><b>Always connect a safety cable with the HP charging line from the charging station to the flask rack frame when charging. Failure to comply with this warning may cause injury or death to personnel.</b></p>						
4	HP Air Supply Hose	N/A	Connect hose to compressor.	HP Air Source		
5	HP Air Supply Hose	N/A	Connect hose to <b>AHP CHARGING</b> bulkhead connector.	Roof Rack Assembly		
6	HP Compressor	N/A	Start and run compressor.	HP Air Source		
7	HP Air Supply Hose	N/A	Pressurize. Check for leaks.	Roof Rack Assembly / HP Air Source		
8	Charge Inlet Valve	AHP-V604	Open slowly.	Roof Rack Assembly		
9	HP Flask Rack Valves	AHP-V501 AHP-V504 AHP-V505 AHP-V506 AHP-V507	Open.	Primary / Secondary Flask Rack Assemblies		
<b>NOTE 10:</b> Do not open <b>AIR SUPPLY OUT</b> valve (AHP-V502) if whip is not attached to <b>AIR SUPPLY NEXT RACK</b> valve (AHP-V501) of another primary or secondary flask rack assembly.						
10	<b>AIR SUPPLY OUT</b> Valves	AHP-V502	Open (all except lowest rack in charging loop).	Primary / Secondary Flask Rack Assemblies		
11	Flask Rack Assemblies (as required)	N/A	Charge to 3,000 psig (maximum).	Primary / Secondary Flask Rack Assembly		

## SS500-HK-MMO-010

OP-3 PRE-DIVE/POST-DIVE: HP FLASK CHARGING PROCEDURE—Continued						
STEP	COMPONENT	DESCRIPTION	PROCEDURE	LOCATION	CHECK	REF
12	Flask Shutoff Valves	AHP-V505 AHP-V506 AHP-V507	Close.	Primary / Secondary Flask Rack Assembly		
13	HP Compressor	N/A	Secure compressor.	HP Air Source		
14	<b>AIR SUPPLY OUT</b> Valve	AHP-V502	Open valve (lowest rack only). Bleed manifolds and hoses. Close valve.	Primary or Secondary Flask Rack Assembly		
15	HP Air Supply Hose	N/A	Disconnect from compressor and <b>AHP CHARGING</b> bulkhead con- nector. Cap bulkhead connector.	HP Air Source / Roof Rack Assembly		
16	HP Flask Rack Valves	AHP-V501 AHP-V502 AHP-V503 AHP-V504 AHP-V505 AHP-V506 AHP-V507	Close or ensure closed (all primary and secondary racks).	Primary / Secondary Flask Rack Assembly		
	Roof Rack Valves	AHP-V601 AHP-V604	Close or ensure closed.	Roof Rack Assembly		
<b>NOTE 11:</b> The following step may be omitted if flasks have been charged with a compressor package using any of the air purification systems found on the ANU list, section 6.1, or any HP air source that provides air at a dew point of -50°F or lower.						
17	Flask Shutoff Valves	AHP-V505 AHP-V506 AHP-V507	Unstack racks as required and drain moisture from flasks in accordance with procedure in Table 2-13.	Primary / Secondary Flask Rack Assembly		
18	Dust Caps	N/A	Reinstall.	System		
<b>NOTE 12:</b> Perform post-steps D thru F only if pre-steps A thru C were performed at the beginning of this procedure.						
D	Secondary Deck Hose	H-102	Uncap AHP-V502 (secondary rack) and H-102. Connect H-102 to AHP-V502.	Secondary Flask Rack Assembly		
E	Flask Whip	AHP-V501 (secondary) to AHP-V502 (primary)	Loosen at AHP-V501 (secondary rack) and disconnect from AHP- V502 (lowest primary rack). Tighten whip connector and bag free end of whip.	Primary / Secondary Flask Rack Assemblies		
F	Primary Deck Hose	H-102	Uncap hose and connect to AHP- V502 on lowest primary rack (first stack, bottom rack if multiple stacks).	Primary Flask Rack Assembly		



## SS500-HK-MMO-010

OP-4 PREDIVE START-UP: DIVER EQUIPMENT						
DATE: _____						
NOTE 1: See Table 2-14 for detailed procedures.						
NOTE 2: Record notes and deficiencies in section provided at the end of this operating procedure.						
STEP	COMPONENT	DESCRIPTION	PROCEDURE	LOCATION	CHECK	REF
1	Diver Umbilicals	N/A	Connect umbilicals to <b>DIVER AIR</b> and <b>DIVER DEPTH</b> bulkhead connectors.	Control Console Assembly		
2	<b>SUPPLY SELECTOR</b> Valve	ALP-V302	Switch to <b>PRIMARY SUPPLY</b> .	Control Console Assembly		
<div style="border: 1px solid black; padding: 2px; display: inline-block; margin: 0 auto;">WARNING</div> <p><b>For the following step, maintain a firm grip on the hose and point the free end away from personnel to avoid injury from flying debris.</b></p>						
3	<b>DIVER AIR / DIVER DEPTH</b> Valves	ALP-V304 ALP-V305 ALP-V306 ALP-V312 ALP-V313 ALP-V314	Open slowly. Purge hoses. Close.	Control Console Assembly		
4	Diver Umbilicals	N/A	Connect to UBAs. Complete UBA premission and predive checklists.	Control Console Assembly		
NOTE 3: Commence dive in accordance with unit dive plan and Standard Operating Procedures per the <i>U.S. Navy Diving Manual</i> , NAVSEA SS521-AG-PRO-010.						
NOTE 4: If primary supply pressure drops below minimum manifold pressure during the dive, proceed immediately to EP-1, <i>Emergency Procedure: Loss of Primary Air</i> .						
NOTE 5: If flasks require charging during the dive, refer to OP-5, <i>During OPs: HP Flask Charging Procedure</i> .						
NOTE 6: Upon completion of the dive, proceed to the appropriate shutdown procedure in OP-6 or OP-6M.						
REMARKS: (Using step number as a reference, list any deficiencies or problems found during performance of this procedure.)						





## SS500-HK-MMO-010

OP-5 DURING OPS: HP FLASK CHARGING PROCEDURE						
DATE: _____						
NOTE 1: See Table 2-15 for detailed procedures.						
NOTE 2: Record notes and deficiencies in section provided at the end of this operating procedure.						
STEP	COMPONENT	DESCRIPTION	PROCEDURE	LOCATION	CHECK	REF
<div style="border: 1px solid black; padding: 5px; display: inline-block; margin-bottom: 10px;"><b>WARNINGS</b></div> <p><b>Use only Authorized for Navy Use (ANU) approved HP compressors with moisture separators and filtration for charging LWDS HP air flasks. Refer to <i>Diving Equipment Authorized for U.S. Navy Use (ANU)</i> list for approved HP compressors.</b></p> <p><b>Always connect a safety cable with the HP charging line from the charging station to the flask rack frame when charging. Failure to comply with this warning may cause injury or death to personnel.</b></p>						
1	HP Air Supply Hose	N/A	Connect hose to <b>AHP CHARGING</b> bulkhead connector.	Roof Rack Assembly		
2	HP Air Supply Hose	N/A	Connect hose to compressor.	HP Air Source		
3	HP Compressor	N/A	Start and run compressor.	HP Air Source		
<div style="border: 1px solid black; padding: 5px; display: inline-block; margin-bottom: 10px;"><b>WARNING</b></div> <p><b>Never charge the lowest primary flask rack assembly in the breathing loop during a dive. Failure to comply with this warning may cause injury or death to divers.</b></p>						
4	<b>AIR SUPPLY OUT</b> Valve	AHP-V502	Close AHP-V502 (lowest rack to be charged).	Primary Flask Rack Assembly		
5	HP Air Supply Hose	N/A	Pressurize hose. Check for leaks.	HP Air Source / Roof Rack Assembly		
6	Charge Inlet Valve	AHP-V604	Open slowly.	Roof Rack Assembly		
7	Flask Rack Assemblies (as required)	N/A	Charge to 3,000 psig (maximum).	Primary Flask Rack Assembly		

SS500-HK-MMO-010

<p style="text-align: center;"><b>OP-5</b>  <b>DURING OPS: HP FLASK CHARGING PROCEDURE—Continued</b></p>						
STEP	COMPONENT	DESCRIPTION	PROCEDURE	LOCATION	CHECK	REF
8	Charge Inlet Valve	AHP-V604	Close.	Roof Rack Assembly		
9	HP Compressor	N/A	Shut down.	HP Air Source		
10	<b>AIR SUPPLY OUT</b> Valve	AHP-V502	Open valve closed in step 4. Racks will automatically cascade.	Primary Flask Rack Assembly		
<p><b>NOTE 3:</b> Repeat steps 3 thru 10 as necessary for continued diving operations.</p>						
11	HP Air Supply Hose / HP Compressor	N/A	If end of mission, disconnect hose from compressor and <b>AHP CHARGING</b> bulkhead connector. Secure compressor.	HP Air Source / Roof Rack Assembly		

**REMARKS:** (Using step number as a reference, list any deficiencies or problems found during performance of this procedure.)

---



---



---



---



---



---



---



---



---



---



---



---



---



---



---



---

Performed By: \_\_\_\_\_  
 Printed Name and Signature

Noted and Checked By: \_\_\_\_\_  
 Diving Supervisor's Signature

## SS500-HK-MMO-010

OP-6 POSTDIVE SHUTDOWN PROCEDURES: CONFIGURATIONS 1, 2, AND 3						
DATE: _____						
<b>NOTE 1:</b> See Table 2-16 for detailed procedures. This checklist is used for short breaks that are expected to exceed 24 hours, and also as part of the postmission procedures at the conclusion of the dive mission (see OP-7). If diving operations are expected to continue within 24 hours, the modified shutdown procedures may be used instead (see OP-6M).						
<b>NOTE 2:</b> Record notes and deficiencies in section provided at the end of this operating procedure.						
STEP	COMPONENT	DESCRIPTION	PROCEDURE	LOCATION	CHECK	REF
<b>NOTE 3:</b> If diving supervisor determines that flasks need to be charged before or during performance of this procedure, refer to OP-3, <i>Pre-dive/Post-dive: HP Flask Charging Procedure</i> . Ensure that valves are returned to previous settings prior to continuing this procedure or beginning the next procedure.						
PART I - POSTDIVE SHUTDOWN PROCEDURES FOR CONFIGURATION 1						
<b>CAUTION</b>						
Never stop the diesel engine with the decompressors. Failure to comply with this caution may result in valve damage to engine.						
1	Diesel Engine Stop/Run Cable	N/A	Pull up to stop engine.	Diesel-Compressor Assembly		
<b>WARNINGS</b>						
Do not fill the fuel tank while it is mounted on the diesel-compressor assembly. The fuel tank shall be disconnected and moved away from the immediate vicinity of the diving equipment prior to refueling. Failure to observe this warning could result in a fuel spill, creating an immediate fire hazard and possibly causing contamination of the diving equipment, all of which could result in injury or death to personnel and damage to the equipment.						
The LWDS is designed to operate in ambient temperatures of 40°-100°F. When operating in temperatures below 40°F, the diesel-compressor assembly requires the use of special fuels and lubricants. Failure to use the prescribed diesel fuel and lubricating oils could result in injury or death to divers or support personnel and damage to the equipment.						
<b>CAUTIONS</b>						
Use diesel fuel only. Ensure fuel tank vent is open.						
Fuel contamination can cause damage to the fuel injection system resulting in engine failure.						
2	Diesel Engine Fuel Tank	N/A	Check fuel level. Refuel as required (Figure A-9).	Diesel-Compressor Assembly		

## SS500-HK-MMO-010

OP-6 POSTDIVE SHUTDOWN PROCEDURES: CONFIGURATIONS 1, 2, AND 3—Cont.						
STEP	COMPONENT	DESCRIPTION	PROCEDURE	LOCATION	CHECK	REF
<b>PART I - POSTDIVE SHUTDOWN PROCEDURES FOR CONFIGURATION 1—Continued</b>						
3	Diesel Engine Dipstick	N/A	Check engine oil level. Add oil as required (Figure A-9); do not overfill.	Diesel-Compressor Assembly		
4	Compressor Sight Glass	N/A	Check compressor oil level. Add oil as required (Figure A-9). Fill to red dot; do not overfill.	Diesel-Compressor Assembly		
5	<b>DIVER DEPTH</b> Valves	ALP-V312 ALP-V313 ALP-V314	Close.	Control Console Assembly		
6	Flask Shutoff Valves	AHP-V505 AHP-V506 AHP-V507	Close.	Secondary Flask Rack Assembly		
7	<b>SUPPLY SELECTOR</b> Valve	ALP-V302	Switch to <b>SECONDARY SUPPLY</b> .	Control Console Assembly		
<div style="border: 1px solid black; padding: 5px; width: fit-content; margin: 0 auto;"><b>WARNING</b></div> <p><b>Before bleeding HP air, ensure all personnel are clear of area to avoid injury from flying debris. Operator must wear protective eye wear when bleeding system.</b></p>						
8	UBA Purge Button	N/A	Push UBA purge button. Bleed secondary HP system.	UBA Face Mask		
9	Manual Adjust Regulator	AHP-V307	Unload.	Control Console Assembly		
10	<b>SUPPLY SELECTOR</b> Valve	ALP-V302	Switch to <b>PRIMARY SUPPLY</b> .	Control Console Assembly		
11	<b>LP AIR OUT</b> Valve	ALP-V210	Close.	Volume Tank Assembly		
<div style="border: 1px solid black; padding: 5px; width: fit-content; margin: 0 auto;"><b>WARNING</b></div> <p><b>Before bleeding LP air, ensure all personnel are clear of area to avoid injury from flying debris. Operator must wear protective eye wear when bleeding system.</b></p>						
12	UBA Purge Button	N/A	Push UBA purge button. Bleed primary LP system.	UBA Face Mask		
13	<b>DIVER AIR</b> Valves	ALP-V304 ALP-V305 ALP-V306	Close.	Control Console Assembly		

## SS500-HK-MMO-010

OP-6 POSTDIVE SHUTDOWN PROCEDURES: CONFIGURATIONS 1, 2, AND 3—Cont.						
STEP	COMPONENT	DESCRIPTION	PROCEDURE	LOCATION	CHECK	REF
<b>PART I - POSTDIVE SHUTDOWN PROCEDURES FOR CONFIGURATION 1—Continued</b>						
14	<b>SUPPLY SELECTOR Valve</b>	ALP-V302	Switch to <b>CLOSE</b> .	Control Console Assembly		
15	Compressor Drain Valve	ALP-V402	Open. Drain moisture. Close.	Diesel-Compressor Assembly		
	Volume Tank Drain Valves	ALP-V205 ALP-V208 ALP-V209		Volume Tank Assembly		
16	<u>Valves</u> Regulator	AHP-V201	Ensure closed or unloaded.	Volume Tank Assembly		
	Gauge Isolation	AHP-V202				
	Gauge Isolation	ALP-V204				
	LP Air Out	ALP-V210				
	Gauge Isolation	ALP-V301		Control Console Assembly		
	Supply Selector	ALP-V302				
	Diver Air (R)	ALP-V304				
	Diver Air (G)	ALP-V305				
	Diver Air (Y)	ALP-V306				
	Regulator	AHP-V307				
Gauge Isolation	AHP-V309	Diesel-Compressor Assembly				
Gauge Isolation	ALP-V310					
Diver Depth (R)	ALP-V312					
Diver Depth (G)	ALP-V313					
Diver Depth (Y)	ALP-V314	Secondary Flask Rack Assembly				
LP Air Out	ALP-V401					
Drain Valve	ALP-V402					
Gauge Isolation	ALP-V405	Roof Rack Assembly				
Air Supply	AHP-V501					
Next Rack						
Air Supply Out			AHP-V502			
Gauge Isolation	AHP-V503					
Air Supply	AHP-V504					
This Rack						
Gauge Isolation	AHP-V601					
Charge Inlet	AHP-V604					
<b>NOTE 4:</b> If the dive mission is complete, proceed to OP-7, <i>Postmission Procedures: Configurations 1, 2, and 3</i> . If the dive mission is not complete, perform all required steps in OP-2.1 and OP-2.2 before proceeding to OP-4, <i>Pre-dive Start-Up: Diver Equipment</i> .						
<b>PART II - POSTDIVE SHUTDOWN PROCEDURES FOR CONFIGURATIONS 2 AND 3</b>						
1	<b>DIVER DEPTH Valves</b>	ALP-V312 ALP-V313 ALP-V314	Close.	Control Console Assembly		

## SS500-HK-MMO-010

OP-6 POSTDIVE SHUTDOWN PROCEDURES: CONFIGURATIONS 1, 2, AND 3—Cont.						
STEP	COMPONENT	DESCRIPTION	PROCEDURE	LOCATION	CHECK	REF
<b>PART II - POSTDIVE SHUTDOWN PROCEDURES FOR CONFIGURATIONS 2 AND 3—Continued</b>						
2	Flask Shutoff Valves	AHP-V505 AHP-V506 AHP-V507	Close (all primary and secondary racks).	Primary / Secondary Flask Rack Assemblies		
3	<b>SUPPLY SELECTOR</b> Valve	ALP-V302	Switch to <b>SECONDARY SUPPLY</b> .	Control Console Assembly		
<div style="border: 1px solid black; padding: 2px; display: inline-block;"><b>WARNING</b></div> <p><b>Before bleeding HP air, ensure all personnel are clear of area to avoid injury from flying debris. Operator must wear protective eye wear when bleeding system.</b></p>						
4	UBA Purge Button	N/A	Push UBA purge button. Bleed secondary system.	UBA Face Mask		
5	Manual Adjust Regulator	AHP-V307	Unload.	Control Console Assembly		
6	<b>SUPPLY SELECTOR</b> Valve	ALP-V302	Switch to <b>PRIMARY SUPPLY</b> .	Control Console Assembly		
7	<b>LP AIR OUT</b> Valve	ALP-V210	Close.	Volume Tank Assembly		
<div style="border: 1px solid black; padding: 2px; display: inline-block;"><b>WARNING</b></div> <p><b>Before bleeding LP air, ensure all personnel are clear of area to avoid injury from flying debris. Operator must wear protective eye wear when bleeding system.</b></p>						
8	UBA Purge Button	N/A	Push UBA purge button. Bleed primary LP system.	UBA Face Mask		
9	<b>DIVER AIR</b> Valves	ALP-V304 ALP-V305 ALP-V306	Close.	Control Console Assembly		
10	<b>SUPPLY SELECTOR</b> Valve	ALP-V302	Switch to <b>CLOSE</b> .	Control Console Assembly		
11	Drain Valves	ALP-V205 ALP-V208 ALP-V209	Open. Drain moisture. Close.	Volume Tank Assembly		

## SS500-HK-MMO-010

OP-6 POSTDIVE SHUTDOWN PROCEDURES: CONFIGURATIONS 1, 2, AND 3—Cont.							
STEP	COMPONENT	DESCRIPTION	PROCEDURE	LOCATION	CHECK	REF	
<b>PART II - POSTDIVE SHUTDOWN PROCEDURES FOR CONFIGURATIONS 2 AND 3—Continued</b>							
12	Valves Regulator Gauge Isolation Gauge Isolation LP Air Out ..... Gauge Isolation Supply Selector Diver Air (R) Diver Air (G) Diver Air (Y) Regulator Gauge Isolation Gauge Isolation Diver Depth (R) Diver Depth (G) Diver Depth (Y) ..... Air Supply Next Rack Air Supply Out Gauge Isolation Air Supply This Rack ..... Gauge Isolation Charge Inlet	AHP-V201 AHP-V202 ALP-V204 ALP-V210 ..... ALP-V301 ALP-V302 ALP-V304 ALP-V305 ALP-V306 AHP-V307 AHP-V309 ALP-V310 ALP-V312 ALP-V313 ALP-V314 ..... AHP-V501 AHP-V502 AHP-V503 AHP-V504 ..... AHP-V601 AHP-V604	Ensure closed or unloaded.	Volume Tank Assembly ..... Control Console Assembly ..... Primary / Secondary Flask Rack Assemblies ..... Roof Rack Assembly			
<b>NOTE 5:</b> The following step may be omitted if flasks have been charged with a compressor package using any of the air purification systems found on the ANU list, section 6.1, or any HP air source that provides air at a dew point of -50°F or lower.							
13	Flask Shutoff Valves	AHP-V505 AHP-V506 AHP-V507	If flasks were charged during dive, unstack racks as required and drain moisture from flasks in accordance with procedure in Table 2-16.	Primary / Secondary Flask Rack Assemblies			
<b>NOTE 6:</b> If the dive mission is complete, proceed to OP-7, <i>Postmission Procedures: Configurations 1, 2, and 3</i> . If the dive mission is not complete, perform all required steps in OP-2.3 and OP-2.4 before proceeding with OP-4, <i>Pre-dive Start-Up: Diver Equipment</i> .							
<b>REMARKS:</b> (Using configuration and step number as a reference, list any deficiencies or problems found during performance of this procedure.)          							





## SS500-HK-MMO-010

<b>OP-6M</b>						
<b>MODIFIED SHUTDOWN PROCEDURE: CONFIGURATIONS 1, 2, AND 3</b>						
<b>DATE:</b> _____						
<b>NOTE 1:</b> See Table 2-17 for detailed procedures. This OP may be used any time the equipment will be used again within 24 hours. If it is anticipated that more than 24 hours will pass before using the equipment again, the shutdown procedures in OP-6 must be performed instead.						
<b>NOTE 2:</b> Record notes and deficiencies in section provided at the end of this operating procedure.						
<b>STEP</b>	<b>COMPONENT</b>	<b>DESCRIPTION</b>	<b>PROCEDURE</b>	<b>LOCATION</b>	<b>CHECK</b>	<b>REF</b>
<b>NOTE 3:</b> If flasks require charging immediately before, during, or after performance of this procedure, refer to OP-3, <i>Pre-dive/Post-dive: HP Flask Charging Procedure</i> . Ensure valves are returned to previous settings prior to continuing this procedure or beginning the next one.						
1	<b>DIVER DEPTH</b> Valves	ALP-V312 ALP-V313 ALP-V314	Close.	Control Console Assembly		
2	<b>DIVER AIR</b> Valves	ALP-V304 ALP-V305 ALP-V306	Close.	Control Console Assembly		
3	<b>SUPPLY SELECTOR</b> Valve	ALP-V302	Switch to <b>CLOSE</b> .	Control Console Assembly		
4	Manual Adjust Regulator	AHP-V307	Ensure fully counterclockwise (CCW).	Control Console Assembly		
5	<b>LP AIR OUT</b> Valve	ALP-V210	Close.	Volume Tank Assembly		
<div style="border: 1px solid black; padding: 5px; width: fit-content; margin: 0 auto;"><b>CAUTION</b></div> <p style="text-align: center;">Never stop the diesel engine with the decompressors. Failure to comply with this caution may result in valve damage to engine.</p>						
6	<b>LP AIR OUT</b> Valve Pilot Valve Stop/Run Cable	ALP-V401 ALP-V403  N/A	For Configuration 1 only: Ensure ALP-V401 is closed and ALP-V403 is unloaded. Pull up stop/run cable to stop engine.	Diesel- Compressor Assembly		
	Manual Adjust Regulator	AHP-V201	For Configurations 2 and 3 only: Ensure fully counterclockwise (CCW).	Volume Tank Assembly		
7	<b>AIR SUPPLY OUT</b> Valve	AHP-V502	Close as required (all primary and secondary racks).	Primary / Secondary Flask Rack Assemblies		



## SS500-HK-MMO-010

OP-7 POSTMISSION PROCEDURES: CONFIGURATIONS 1, 2, AND 3						
DATE: _____						
NOTE 1: See Table 2-18 for detailed procedures.						
NOTE 2: Record notes and deficiencies in section provided at the end of this operating procedure.						
STEP	COMPONENT	DESCRIPTION	PROCEDURE	LOCATION	CHECK	REF
PART I - POSTMISSION PROCEDURES FOR CONFIGURATION 1						
NOTE 3: Prior to performing Step 1, ensure the procedures described in OP-6, <i>Part I - Postdive Shutdown Procedures for Configuration 1</i> , have been conducted.						
1	<b>GAUGE ISOLATION Valve</b>	ALP-V204	Open.	Volume Tank Assembly		
2	Drain Valve	ALP-V208	Open. Bleed volume tank to ~50 psig. Close.	Volume Tank Assembly		
3	Pre-filter Condensate Drain Valve	ALP-V205	Open. Bleed hose H-104. Close.	Volume Tank Assembly		
4	Diver Umbilicals	N/A	Disconnect umbilicals. Cap/bag as required.	Control Console Assembly		
5	<b>GAUGE ISOLATION Valve</b>	ALP-V204	Close.	Volume Tank Assembly		
6	Deck Hoses	H-101 H-102 H-104	Disconnect hoses. Inspect for damage. Cap/bag as required.	System		
7	Wheels	N/A	Reinstall.	Diesel-Compressor Assembly		
8	Air Intake Hose / Snorkel Assembly	N/A	Disconnect hose. Disassemble snorkel assembly.	Diesel-Compressor Assembly		
9	Control Console Assembly	N/A	Remove from platform. Reinstall and secure cover.	Control Console Assembly		
10	Volume Tank Assembly	N/A	Disassemble. Reinstall and secure covers.	Volume Tank Assembly		
11	Flask Whips	AHP-V501 to <b>AHP OUT</b> _____ AHP-V501 to AHP-V502	Disconnect and secure whips. Cap <b>AHP OUT</b> .	Roof Rack Assembly / Secondary Flask Rack Assembly		

## SS500-HK-MMO-010

OP-7 POSTMISSION PROCEDURES: CONFIGURATIONS 1, 2, AND 3—Continued						
STEP	COMPONENT	DESCRIPTION	PROCEDURE	LOCATION	CHECK	REF
<b>PART I - POSTMISSION PROCEDURES FOR CONFIGURATION 1—Continued</b>						
12	Roof Rack Assembly	N/A	Remove.	Secondary Flask Rack Assembly		
<b>NOTE 4:</b> The following step may be omitted if flasks have been charged with a compressor package using any of the air purification systems found on the ANU list, section 6.1, or any HP air source that provides air at a dew point of -50°F or lower.						
13	Flask Shutoff Valves	AHP-V505 AHP-V506 AHP-V507	Drain moisture from flasks in accordance with procedure in Table 2-18.	Secondary Flask Rack Assembly		
<b>NOTE 5:</b> Nonionic Detergent (NID) solution is prepared by mixing 1 teaspoon of nonionic detergent to 1 gallon of warm, fresh water.						
14	System	N/A	Wash, rinse, and dry exterior.	System		
15	System	N/A	Inspect for damage. Conduct PMS as required. Stow.	System		
<b>PART II - POSTMISSION PROCEDURES FOR CONFIGURATIONS 2 AND 3</b>						
<b>NOTE 6:</b> Prior to performing Step 1, ensure the procedures described in OP-6, <i>Part II - Postdive Shutdown Procedures for Configurations 2 and 3</i> , have been conducted.						
1	<b>GAUGE ISOLATION</b> Valve	ALP-V204	Open.	Volume Tank Assembly		
2	Drain Valve	ALP-V208	Open. Bleed volume tank to ~50 psig. Close.	Volume Tank Assembly		
3	Diver Umbilicals	N/A	Disconnect umbilicals. Cap/bag as required.	Control Console Assembly		
4	<b>GAUGE ISOLATION</b> Valve	ALP-V204	Close.	Volume Tank Assembly		
5	Manual Adjust Regulator	AHP-V201	Ensure unloaded.	Volume Tank Assembly		
6	<b>AIR SUPPLY NEXT RACK</b> and <b>AIR SUPPLY OUT</b> Valves	AHP-V501 and AHP-V502	Open (all primary racks).	Primary Flask Rack Assemblies		

## SS500-HK-MMO-010

OP-7 POSTMISSION PROCEDURES: CONFIGURATIONS 1, 2, AND 3—Continued						
STEP	COMPONENT	DESCRIPTION	PROCEDURE	LOCATION	CHECK	REF
<b>PART II - POSTMISSION PROCEDURES FOR CONFIGURATIONS 2 AND 3—Continued</b>						
7	<b>AHP CHARGING</b> Bulkhead Connector	N/A	Uncap.	Roof Rack Assembly		
8	Charge Inlet Valve	AHP-V604	Open slowly. Allow system to bleed down until AHP-G602 reads 0 psig.	Roof Rack Assembly		
9	Charge Inlet Valve	AHP-V604	Close.	Roof Rack Assembly		
10	<b>AIR SUPPLY NEXT RACK</b> and <b>AIR SUPPLY OUT</b> Valves	AHP-V501 and AHP-V502	Close (all primary racks).	Primary Flask Rack Assemblies		
11	<b>AHP CHARGING</b> Bulkhead Connector	N/A	Cap.	Roof Rack Assembly		
12	Deck Hoses	H-101 H-102 (2) H-105 (AR)	Disconnect hoses. Inspect for damage. Cap or bag as required.	System		
13	Control Console Assembly	N/A	Remove from platform. Reinstall and secure cover.	Control Console Assembly		
14	Volume Tank Assembly	N/A	Disassemble. Reinstall and secure covers.	Volume Tank Assembly		
15	Flask Whips	AHP-V501 to AHP-V502 (next rack) ————— AHP-V501 to <b>AHP OUT</b>	Disconnect whips from AHP-V502 (all primary racks). Cap <b>AHP OUT</b> .	Primary Flask Rack Assemblies and Roof Rack Assembly		
16	Flask Whips	AHP-V501 to AHP-V502 (same rack)	Loosen whips at AHP-V501 (all primary racks) and connect free end of each whip to AHP-V502 on same rack. Tighten connectors.	Primary Flask Rack Assemblies		
17	Flask Whip	AHP-V501 to AHP-V502 (same rack)	If only one secondary rack used: Unbag/uncap whip at AHP-V501 and loosen connector. Connect free end of whip to AHP-V502 on same rack. Tighten connectors.	Secondary Flask Rack Assembly (single rack)		

## SS500-HK-MMO-010

OP-7 POSTMISSION PROCEDURES: CONFIGURATIONS 1, 2, AND 3—Continued						
STEP	COMPONENT	DESCRIPTION	PROCEDURE	LOCATION	CHECK	REF
<b>PART II - POSTMISSION PROCEDURES FOR CONFIGURATIONS 2 AND 3—Continued</b>						
18	Flask Whips	AHP-V501 to AHP-V502 (next rack) ——— AHP-V501 to AHP-V502 (same rack)	For multiple secondary racks: Unbag/uncap whip at AHP-V501 (top rack). Disconnect whips at AHP-V502 and loosen connectors at AHP-V501 (all secondary racks). Connect free end of each whip to AHP-V502 on same rack. Tighten connectors.	Secondary Flask Rack Assemblies (multiple racks)		
19	Roof Rack Assembly	N/A	Remove from last stack of primary flask rack assemblies.	Primary Flask Rack Assembly		
20	Flask Racks	N/A	Unstack.	Primary / Secondary Flask Rack Assemblies		
<b>NOTE 7:</b> The following step may be omitted if flasks have been charged with a compressor package using any of the air purification systems found on the ANU list, section 6.1, or any HP air source that provides air at a dew point of -50°F or lower.						
21	Flask Shutoff Valves	AHP-V505 AHP-V506 AHP-V507	Drain moisture from flasks in accordance with procedure in Table 2-18.	Primary / Secondary Flask Rack Assemblies		
<b>NOTE 8:</b> NID solution is prepared by mixing 1 teaspoon nonionic detergent to 1 gallon of warm, fresh water.						
22	System	N/A	Wash, rinse, and dry exterior.	System		
23	System	N/A	Inspect for damage. Conduct PMS as required. Stow.	System		

**REMARKS:** (Using configuration and step number as a reference, list any deficiencies or problems found during performance of this procedure.)





THIS PAGE INTENTIONALLY LEFT BLANK

## SS500-HK-MMO-010

**EP-1**  
**EMERGENCY PROCEDURE: LOSS OF PRIMARY AIR**

DATE: \_\_\_\_\_

**NOTE 1:** See Table 2-19 for detailed procedures.**NOTE 2:** Record notes and deficiencies in section provided at the end of this emergency procedure.

STEP	COMPONENT	DESCRIPTION	PROCEDURE	LOCATION	CHECK	REF
<div style="border: 1px solid black; padding: 5px; width: fit-content; margin: 0 auto;"><b>WARNING</b></div> <p style="text-align: center;"><b>If primary supply pressure drops below minimum manifold pressure, immediately perform the procedure below. Failure to perform this procedure could result in injury or death to divers.</b></p>						
1	<b>SUPPLY SELECTOR Valve</b>	ALP-V302	Switch to <b>SECONDARY SUPPLY</b> .	Control Console Assembly		
2	Divers	N/A	Notify and retrieve.	N/A		
<b>NOTE 3:</b> Upon recovery of divers, refer to Chapter 5 of LWDS MK 3 Mod 0 Operation and Maintenance Manual, NAVSEA SS500-HK-MMO-010, to isolate the cause of the failure.						

**REMARKS:** (List conditions, problems, or deficiencies that may have contributed to the emergency.)

---

---

---

---

---

---

---

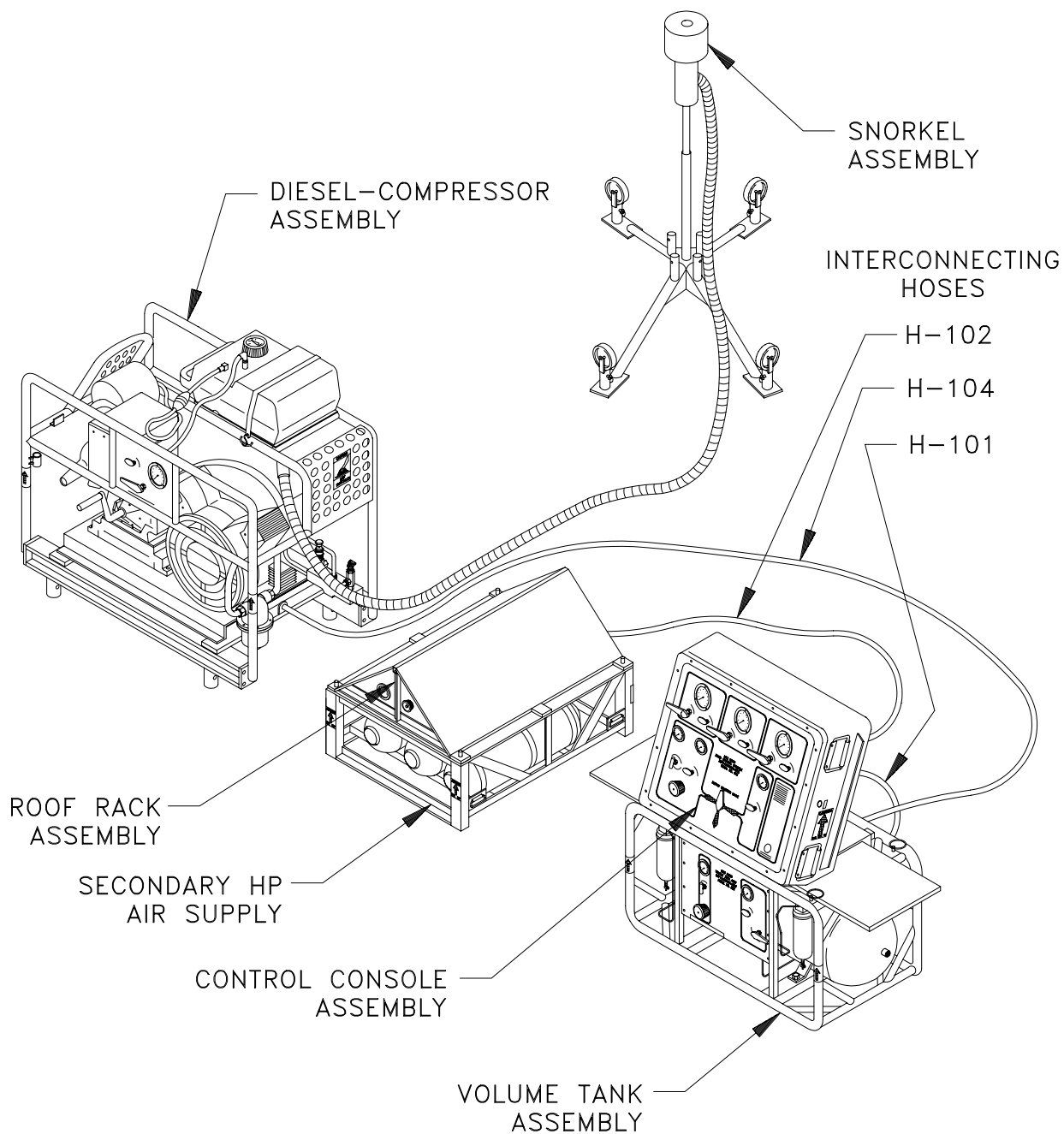
---

---

---

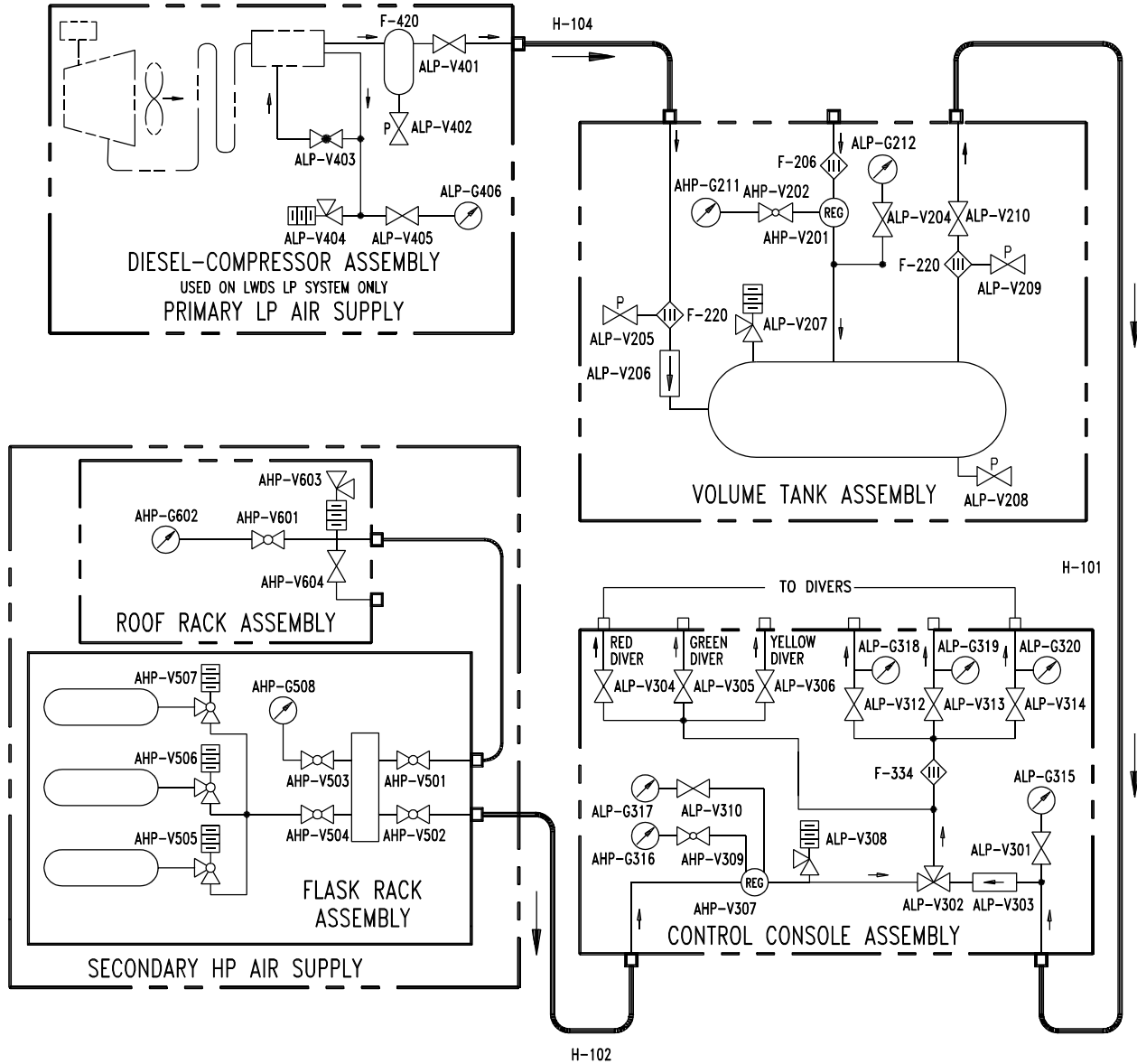
Performed By: \_\_\_\_\_  
Printed Name and SignatureNoted and Checked By: \_\_\_\_\_  
Diving Supervisor's Signature

### SS500-HK-MMO-010



**Figure A-1. Lightweight Dive System (LWDS) MK 3 Mod 0, Configuration 1**

SS500-HK-MMO-010



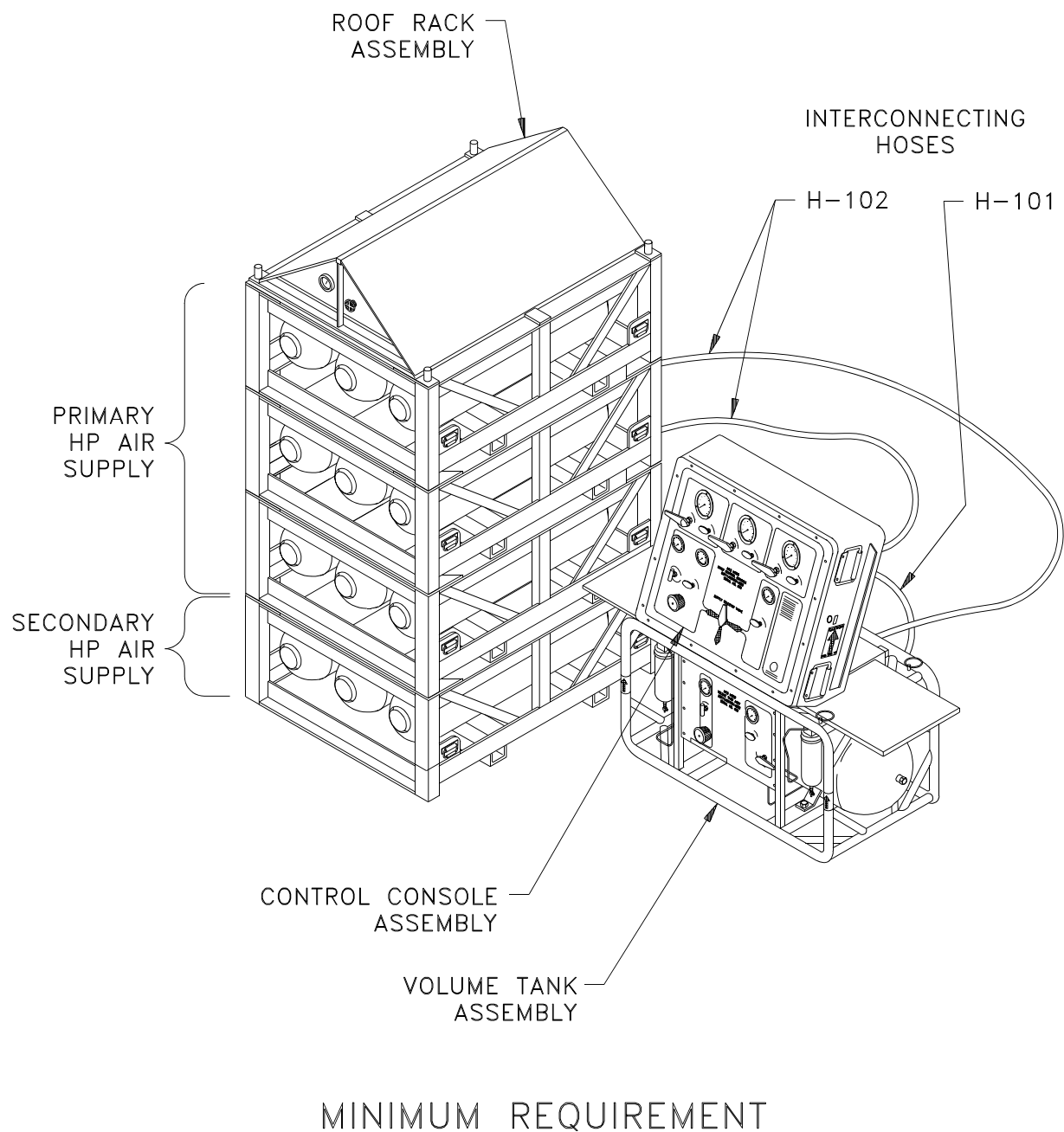
CONFIGURATION 1

COMPONENT LEGEND

	PLUG VALVE		PRESSURE GAUGE		ANGLE SHUTOFF VALVE W/RELIEF
	BALL VALVE		REGULATOR MANUAL ADJUST		FILTER
	CHECK VALVE		SHUTOFF VALVE (NEEDLE)		PILOT VALVE
	RELIEF VALVE		ANGLE SHUTOFF VALVE (NEEDLE)		SELECTOR VALVE

Figure A-2. LWDS MK 3 Mod 0 Schematic, Configuration 1

### SS500-HK-MMO-010



**Figure A-3. Lightweight Dive System (LWDS) MK 3 Mod 0, Configuration 2**

SS500-HK-MMO-010

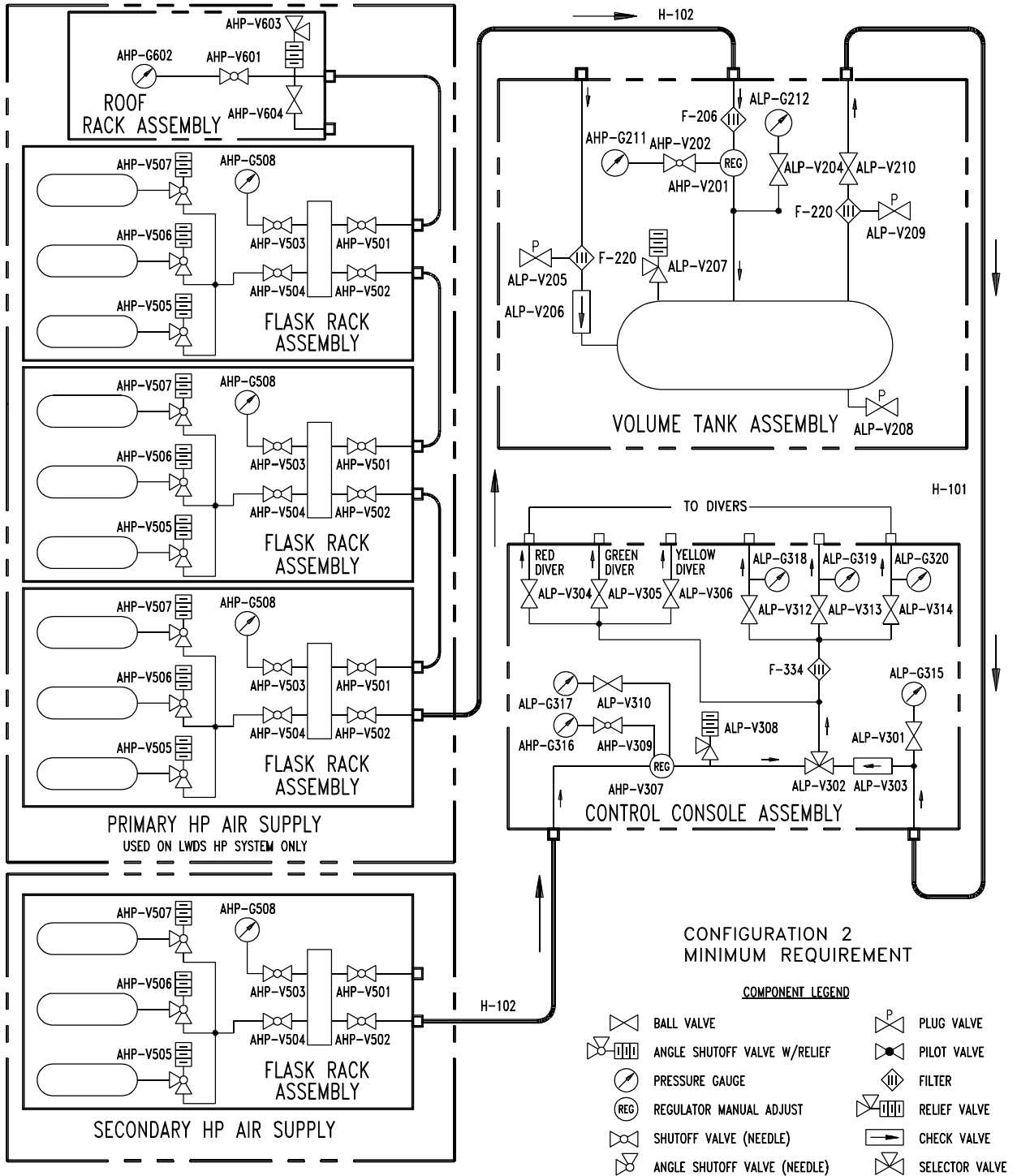


Figure A-4. LWDS MK 3 Mod 0 Schematic, Configuration 2

# SS500-HK-MMO-010

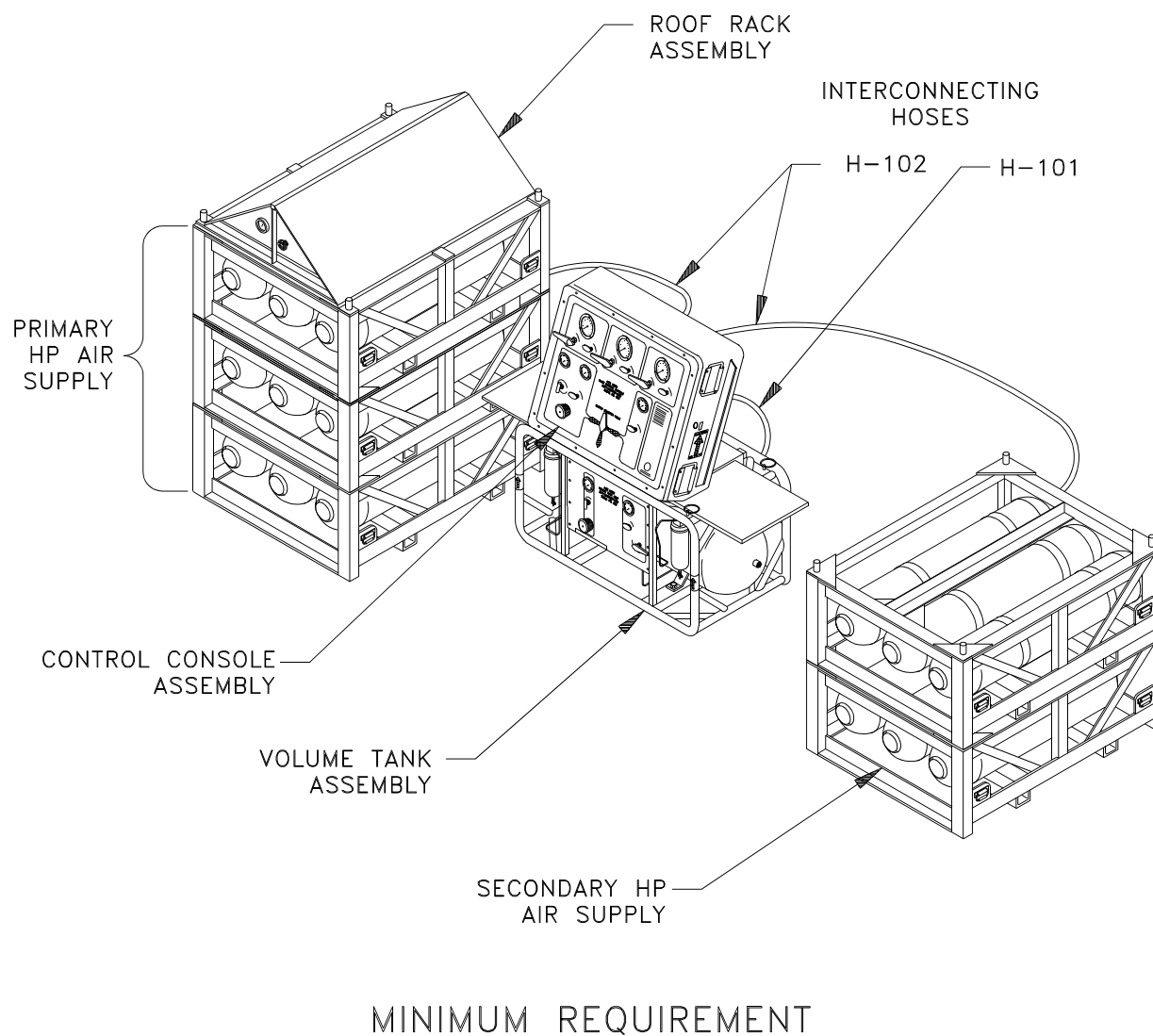


Figure A-5. Lightweight Dive System (LWDS) MK 3 Mod 0, Configuration 3

SS500-HK-MMO-010

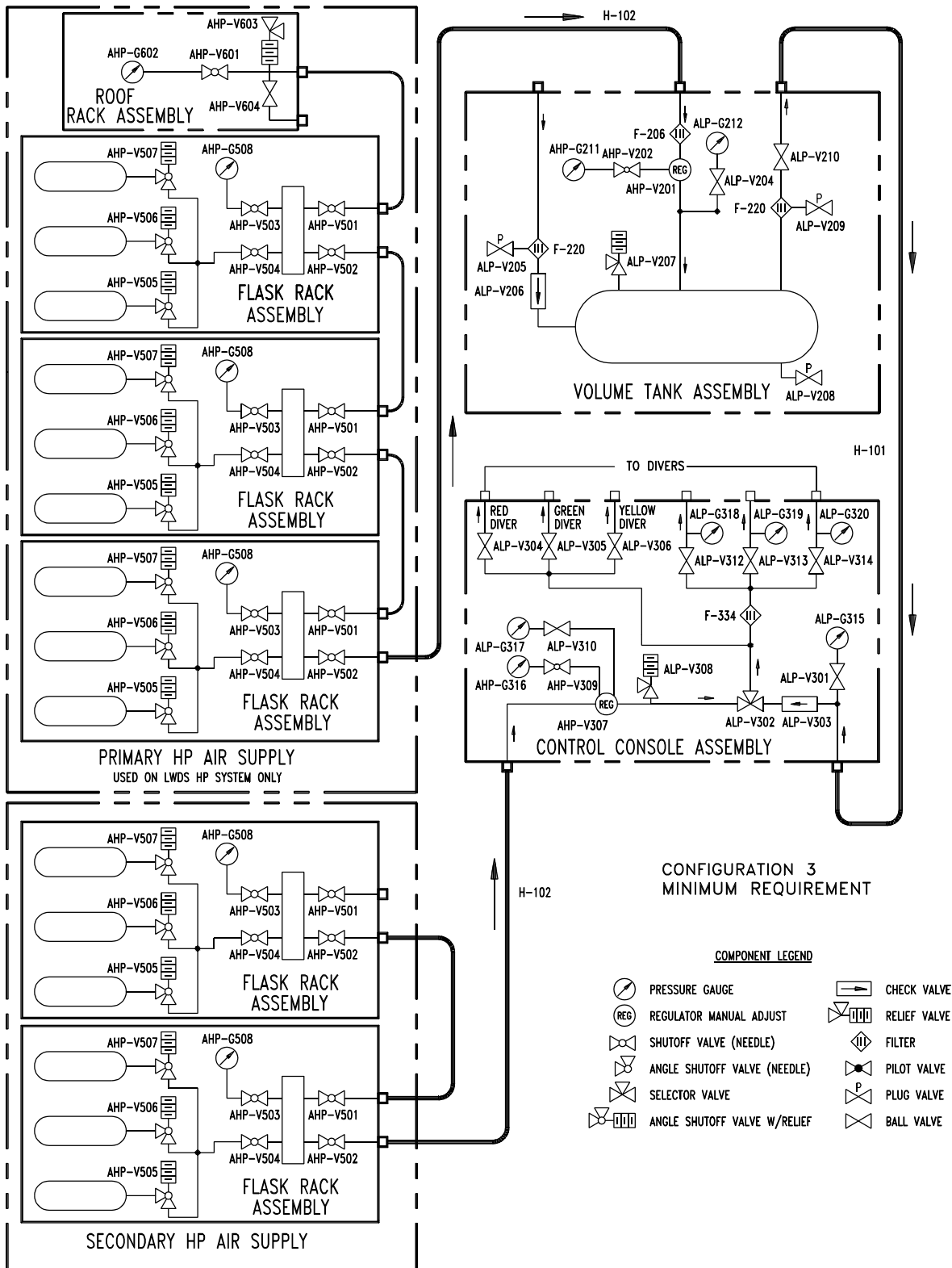
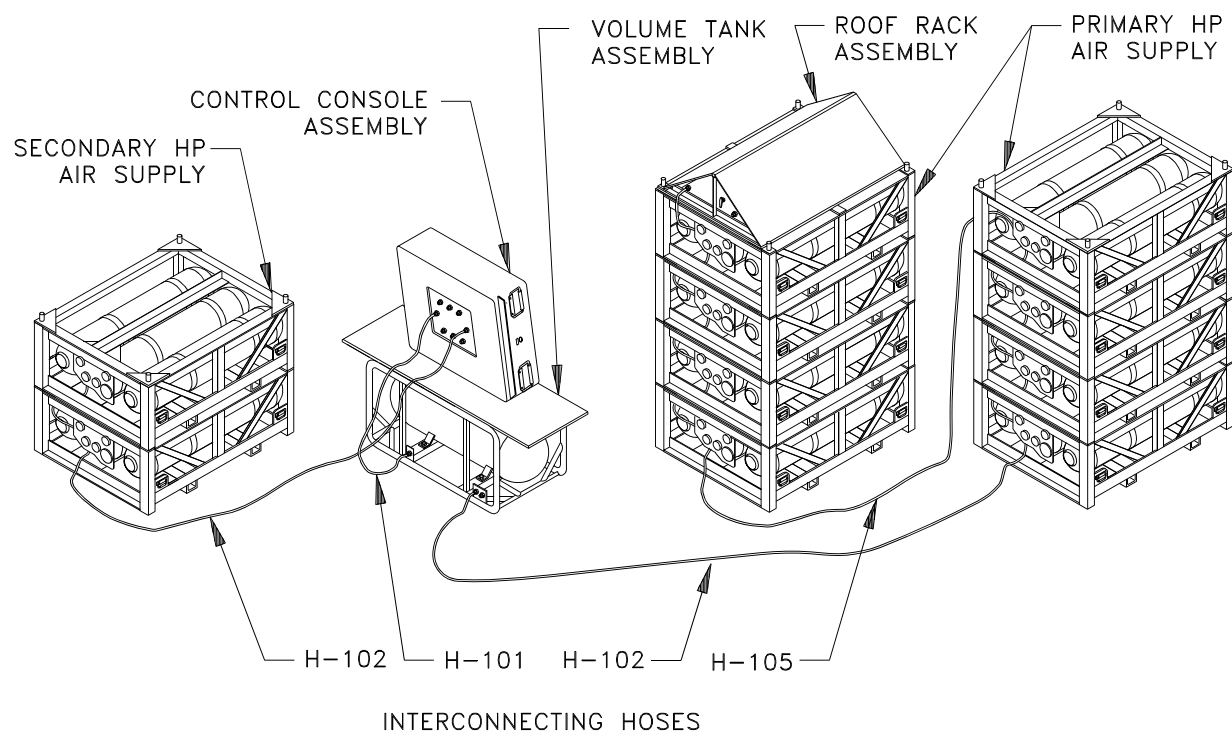


Figure A-6. LWDS MK 3 Mod 0 Schematic, Configuration 3

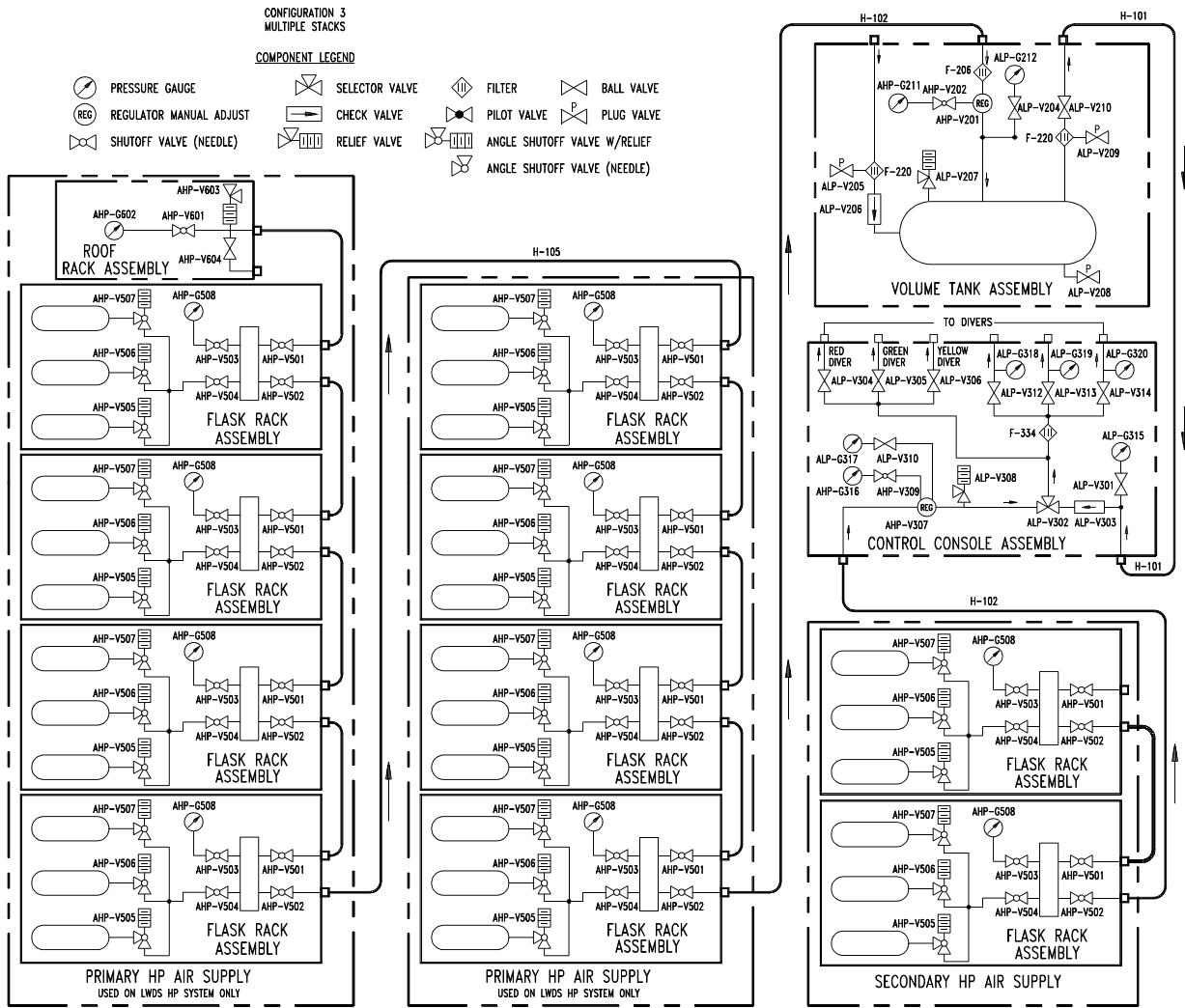


# SS500-HK-MMO-010



**Figure A-7. Lightweight Dive System (LWDS) MK 3 Mod 0, Multiple Stacks of Flask Racks, Configuration 3**

# SS500-HK-MMO-010



**Figure A-8. LWDS MK 3 Mod 0 Schematic,  
Multiple Stacks of Flask Racks, Configuration 3**

## SS500-HK-MMO-010

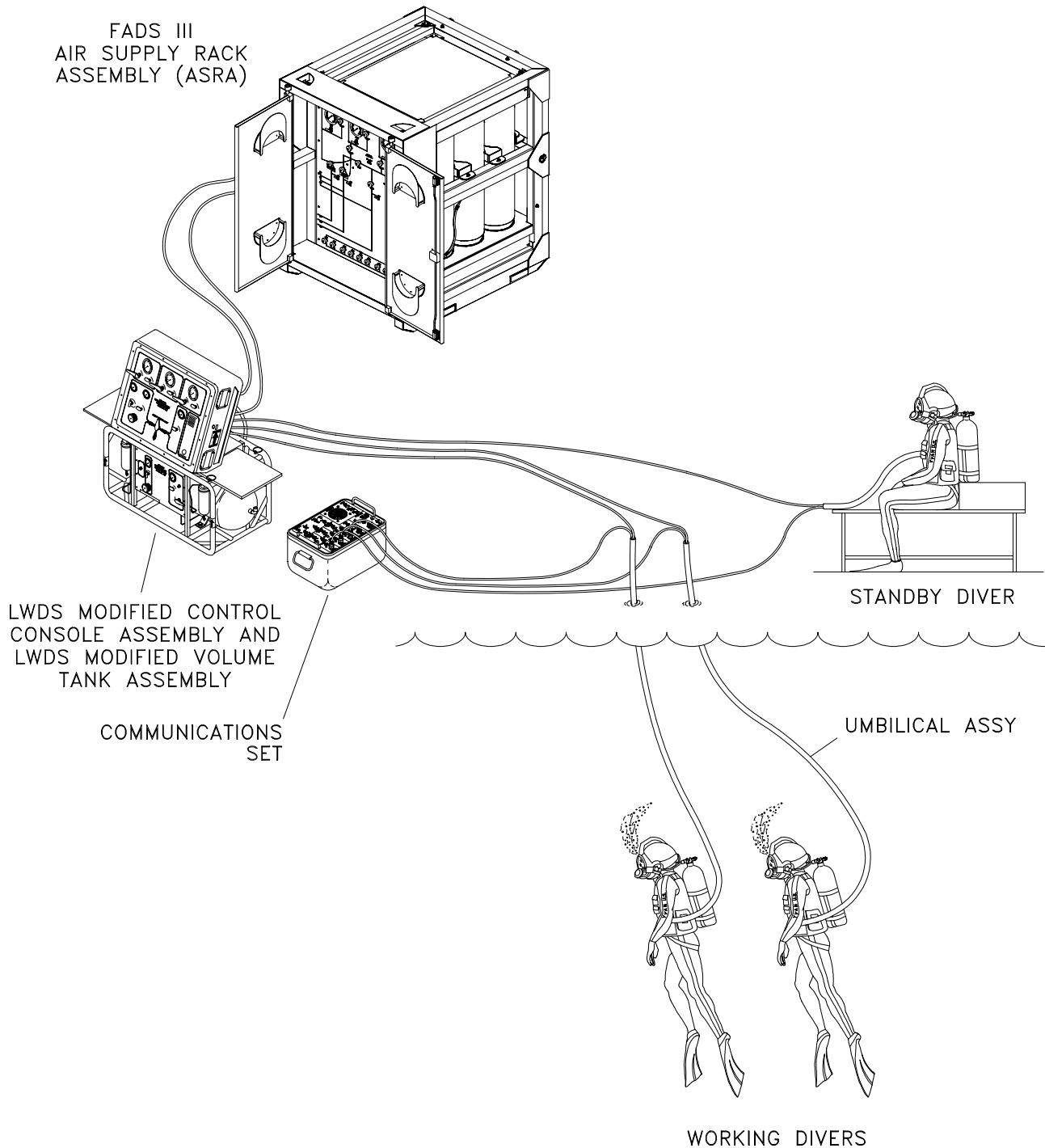
Type	Minimum on Hand	Above 40°F	Below 40°F Above 5°F	Below 5°F
Diesel Fuel	6 gallons	VV-F-800, Grade DF-2	VV-F-800, Grade DF-1 or DF-2 with 2 oz/gal Commercial Anti-Gel Additive	VV-F-800, Grade DF-A or DF-1 with 2 oz/gal Commercial Anti-Gel Additive
Diesel Engine Lubricating Oil	2 quarts	MIL-L-2104C, SAE 30W	MIL-L-2104C, SAE 20W or 15W-40	MIL-L-2104C, SAE 5W or 5W-20
Compressor Lubricating Oil	2 quarts	MIL-L-17331 (2190 TEP)	MIL-L-17672 (2135 TH)	MIL-L-17672 (2135 TH)

Figure A-9. Fuel and Lubrication Chart

**APPENDIX B**

**LIGHTWEIGHT DIVE SYSTEM  
(LWDS) MK 3 MOD 1**

SS500-HK-MMO-010



**Figure B-1. Typical LWDS MK 3 Mod 1 Configuration  
(Shown Supporting Divers Wearing UBA MK 21 Mod 1 Helmets)**

SS500-HK-MMO-010

## APPENDIX B

### LIGHTWEIGHT DIVE SYSTEM (LWDS) MK 3 MOD 1

#### **B.1 INTRODUCTION**

The Lightweight Dive System (LWDS) MK 3 Mod 1 is a portable, self-contained, surface-supplied dive system that typically consists of the following:

- LWDS MK 3 Mod 1 Control Console Assembly
- LWDS MK 3 Mod 1 Volume Tank Assembly
- LWDS MK 3 Mod 0/Mod 1 Volume Tank to Control Console Hose Assembly (H-101)
- 5,000 pounds per square inch (psi) air source, such as the Fly Away Dive System (FADS) III Air Supply Rack Assembly (ASRA) shown in Figure B-1
- High pressure (HP) hose assemblies (supplied with air source)

The LWDS MK 3 Mod 1 can be used to provide breathing air to divers or diver support systems in a variety of mission profiles, including underwater ship's husbandry, construction, salvage, and repair. The Mod 1 is capable of supplying breathing air to one standby diver and two working divers operating at a moderately heavy work rate to a maximum dive depth of 190 feet of seawater (fsw) or to a diver support system such as the Transportable Recompression Chamber System (TRCS). Diver-worn equipment that can be supported by the LWDS MK 3 Mod 1 includes the Underwater Breathing Apparatus (UBA) MK 20 Mod 0 and the UBA MK 21 Mod 1. The LWDS MK 3 Mod 1 is shown supporting UBA MK 21 Mod 1 divers in Figure B-1.

Information that is relevant to both the Mod 0 and the Mod 1 is contained in the main body of this manual, whereas information that is unique to the Mod 1 is provided in this appendix. The Operating Procedures (OPs) and Emergency Procedure (EP) that apply to the Mod 1 are included at the end of this appendix.

#### **NOTE**

The information and procedures presented in this appendix use the FADS III ASRA as the 5,000 psi air source since it has already been authorized by Naval Sea Systems Command (NAVSEA) 00C for use with the LWDS MK 3 Mod 1. To use any other 5,000 psi air source, obtain prior approval from NAVSEA 00C and modify the OPs accordingly.

#### **B.2 FUNCTIONAL DESCRIPTION**

The two major differences between the Mod 0 and the Mod 1 are (1) the Mod 0 uses a 3,000 psi air source and the Mod 1 uses a 5,000 psi air source, and (2) the Mod 0 offers multiple configuration options whereas the Mod 1 has only one standard configuration with two variables (i.e., the air source and the system being supported). In order to safely handle the higher air pressure, the Mod 1 control console and volume tank assemblies have been modified from

## SS500-HK-MMO-010

the Mod 0 design by removing the HP circuit and replacing it with components designed and tested to operate with a primary or secondary air supply pressure of 5,000 psi. The components that are exclusive to the Mod 1 control console assembly include the 0-6,000 psi version of the HIGH PRESSURE IN gauge (AHP-G316), the tubing and fittings from the SECONDARY SUPPLY (HP) inlet up to the tubing nut at the inlet elbow to HP regulator (AHP-V307), and a cross fitting and elbow that allow the addition of a second low pressure (LP) relief valve (ALP-V315). The components exclusive to the Mod 1 volume tank assembly include the 0-6,000 psi version of the H.P. SUPPLY PRESSURE gauge (AHP-G211), the tubing and fittings from the HP AIR IN inlet up to the tubing nut at the inlet elbow to HP regulator (AHP-V201), an HP supply in-line air filter designed to withstand the 5,000 psi air pressure, and an elbow on the volume tank that allows the addition of a second LP relief valve (ALP-V211). Although the Joint Identification Drawing (JID) designations for the two gauges are the same for both the Mod 0 and the Mod 1, the part numbers and the pressure ranges are different for each mod (see paragraph B.9). The additional LP relief valves on the Mod 1 control console and volume tank assemblies are provided to help vent pressure should the load be too high for one relief valve to handle alone.

The LWDS MK 3 Mod 1 functions in much the same way as the Mod 0. Primary HP air flows from designated banks in the ASRA (or other authorized 5,000 psi air source) through an HP hose assembly and into the volume tank assembly where it is reduced to LP air through an HP regulator. The LP air is stored in the volume tank assembly where it is filtered before passing through hose assembly H-101 to the control console assembly. From there, the LP breathing air is delivered to the divers via individual umbilical hoses. In an emergency, secondary HP air supplied from another bank in the ASRA flows through a second HP hose assembly and into the control console assembly where an HP regulator reduces the HP air to LP air before delivering it to the divers.

If further information is desired, refer to Chapter 3 in this manual for functional descriptions of the LWDS MK 3 Mod 0 control console assembly, volume tank assembly, and hose assembly H-101, and to Chapter 3 of the FADS III Air System Operation and Maintenance Manual, NAVSEA S9592-B1-MMO-010, for functional descriptions of the FADS III ASRA and the HP hose assemblies.

### **B.3 REFERENCE DATA**

Table B-1 summarizes the physical characteristics of the LWDS MK 3 Mod 1 using the FADS III ASRA as the 5,000 psi air source. If another authorized 5,000 psi air source is used, refer to the appropriate operation and maintenance manual for more information. Table B-2 provides a list of the equipment, accessories, and documents associated with the LWDS MK 3 Mod 1.

### **B.4 SAFETY PRECAUTIONS**

Refer to the Safety Summary at the front of this manual for an overview of the safety precautions to be observed while operating or maintaining the LWDS MK 3 Mod 1 control console and volume tank assemblies.

## SS500-HK-MMO-010

**Table B-1. LWDS MK 3 Mod 1 Physical Characteristics**

<b>Assembly</b>	<b>Dimensions (Shipping) H×W×L (in.)</b>	<b>Weight (lb)</b>	<b>Capacity</b>
Control Console Assembly, LWDS MK 3 Mod 1	17 × 31 × 33	150	LP - 250 psig HP - 5,000 psig
Volume Tank Assembly, LWDS MK 3 Mod 1	46 × 29 × 28	250	30 gallons (4 cubic feet) LP - 250 psig HP - 5,000 psig
*Air Supply Rack Assembly (ASRA), FADS III (used as 5,000 psi air source)	80 × 64 × 75	3,440 charged 2,800 empty	1,075 scf @ 5,000 psig

\* Use of any other 5,000 psi air source requires prior approval from NAVSEA 00C.

**Table B-2. Equipment, Accessories, and Documents**

<b>Nomenclature</b>	<b>Part Number</b>
Control Console Assembly, LWDS MK 3 Mod 1	53711-6314429
Volume Tank Assembly, LWDS MK 3 Mod 1	53711-6314426
Interconnecting Hose Assembly, LWDS MK 3 Mod 0 / Mod 1: H-101, Volume Tank to Control Console	53711-6314712
Ancillary Equipment, LWDS MK 3 Mod 0 / Mod 1: Shipping Container	53711-6314717
*Air Supply Rack Assembly (ASRA), FADS III	53711-6961893
*Interconnecting Hose Assembly, FADS III: H-436, HP Air Hose Assembly (2 required)	53711-6962000
Documentation: LWDS MK 3 Mod 0 Operation and Maintenance Manual FADS III Air System Operation and Maintenance Manual TRCS MK 6 Mod 0/Mod 1 Operation and Maintenance Manual	SS500-HK-MMO-010 S9592-B1-MMO-010 SS500-AW-MMM-010

\* Use of any other 5,000 psi air source or HP air hose assembly requires prior approval from NAVSEA 00C.

**B.5 EQUIPMENT CHECKLIST**

Table B-3 contains a descriptive checklist of the components, hoses, and adapters that are required to perform operations using the LWDS MK 3 Mod 1. Prior to deployment, ensure the items in Table B-3 are serviced and available for use.



## SS500-HK-MMO-010

**Table B-3. LWDS MK 3 Mod 1 Equipment Checklist**

Item	Component/Description	Qty.
1	Control Console Assembly, LWDS MK 3 Mod 1	1
2	Volume Tank Assembly, LWDS MK 3 Mod 1	1
3	LP Deck Hose (H-101), LWDS MK 3 Mod 0 / Mod 1, 10-ft length, 1/2-in. inside diameter (ID) (37° flare fittings with 3/4-16 thread)	1
4	*Air Supply Rack Assembly (ASRA), FADS III	1
5	*HP Deck Hoses (H-436), FADS III, 42-ft length, 3/8-in. ID, 8,000 psi (1/2-in. CPV fittings)	2
6	Shipping Container, LWDS MK 3 Mod 0 / Mod 1	1

\* Use of any other 5,000 psi air source or HP air hose assembly requires prior approval from NAVSEA 00C.

## **B.6 CONTROLS AND INDICATORS**

Tables B-4 and B-5 list the controls and indicators for the Mod 1 volume tank and control console assemblies. The first column of each table contains index numbers that correspond to the callouts shown in Figures B-2 and B-3 (as indicated). Additional columns contain the panel labels shown on the equipment, Joint Identification Drawing (JID) numbers, and a brief description of each component's function. Prior to conducting operations, ensure all valves are turned fully clockwise in the closed or unloaded position. Turn HP regulators fully counterclockwise to close. Ensure that all pressure indicators read zero, and that all levers and handles are in the OFF or disengaged position.

## **B.7 OPERATION**

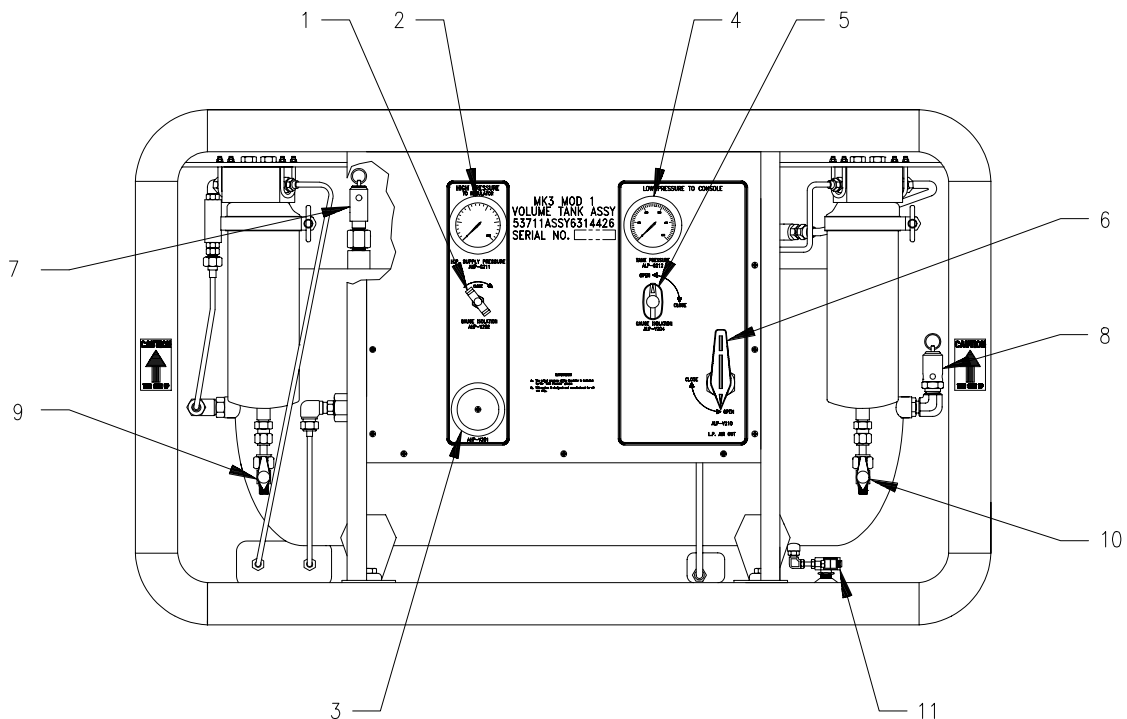
When using the FADS III ASRA as the 5,000 psi air source for the LWDS MK 3 Mod 1, follow the operating instructions given in the Operating Procedures (OPs) at the end of this appendix (see paragraph B.11). If any other 5,000 psi air source is used, prior approval must be obtained from NAVSEA 00C and the OPs must be modified accordingly.

If desired, the Mod 1 volume tank and control console assemblies can be used in place of the Mod 0 assemblies in an LWDS MK 3 Mod 0 configuration. If the Mod 1 assemblies are used, an adapter assembly must be used with the HP hose assemblies. The adapter assembly (PN 53711ASSY6314692) screws into the existing HP hose assemblies and allows attachment to the O-ring face bulkhead fittings on the Mod 1 volume tank and control console assemblies.

## SS500-HK-MMO-010

**Table B-4. LWDS MK 3 Mod 1 Volume Tank Assembly Controls and Indicators**  
(Refer to Figure B-2)

Index No.	Panel Label	JID No.	Function
<b>HIGH PRESSURE TO REGULATOR Panel</b>			
1	GAUGE ISOLATION	AHP-V202	HP Gauge Isolation Valve
2	H.P. SUPPLY PRESSURE	AHP-G211	HP Gauge (0-6,000 psi)
3	AHP-V201	AHP-V201	HP Regulator Control Knob
<b>LOW PRESSURE TO CONSOLE Panel</b>			
4	TANK PRESSURE	ALP-G212	LP Gauge (0-500 psi)
5	GAUGE ISOLATION	ALP-V204	LP Gauge Isolation Valve
6	L.P. AIR OUT	ALP-V210	LP Supply Valve
<b>Relief Valves</b>			
7	N/A	ALP-V207	LP Relief Valve #1
8	N/A	ALP-V211	LP Relief Valve #2
<b>Drain Valves</b>			
9	N/A	ALP-V205	Pre-filter Condensate Drain Valve
10	N/A	ALP-V209	Final Filter Condensate Drain Valve
11	N/A	ALP-V208	Volume Tank Drain Valve



**Figure B-2. LWDS MK 3 Mod 1 Volume Tank Assembly**

## SS500-HK-MMO-010

**Table B-5. LWDS MK 3 Mod 1 Control Console Assembly Controls and Indicators**  
(Refer to Figure B-3)

Index No.	Panel Label	JID No.	Function
<b>SECONDARY SUPPLY Panel</b>			
1	AHP-V307	AHP-V307	HP Regulator Control Knob
2	GAUGE ISOLATION	ALP-V310	LP Out Gauge Isolation Valve
3	GAUGE ISOLATION	AHP-V309	HP In Gauge Isolation Valve
4	HIGH PRESSURE IN	AHP-G316	HP Gauge (0-6,000 psi)
5	LOW PRESSURE OUT	ALP-G317	LP Gauge (0-500 psi)
<b>Red DIVER AIR / DIVER DEPTH Panel</b>			
6	DIVER AIR	ALP-V304	Red Diver's Air Supply Valve
7	ALP-G318	ALP-G318	Red Diver's Depth Gauge (0-350 fsw)
8	DIVER DEPTH	ALP-V312	Red Diver's Depth Gauge Isolation Valve
<b>Green DIVER AIR / DIVER DEPTH Panel</b>			
9	DIVER AIR	ALP-V305	Green Diver's Air Supply Valve
10	ALP-G319	ALP-G319	Green Diver's Depth Gauge (0-350 fsw)
11	DIVER DEPTH	ALP-V313	Green Diver's Depth Gauge Isolation Valve
<b>Yellow DIVER AIR / DIVER DEPTH Panel</b>			
12	DIVER AIR	ALP-V306	Yellow Diver's Air Supply Valve
13	ALP-G320	ALP-G320	Yellow Diver's Depth Gauge (0-350 fsw)
14	DIVER DEPTH	ALP-V314	Yellow Diver's Depth Gauge Isolation Valve
<b>PRIMARY SUPPLY Panel</b>			
15	LOW PRESSURE SUPPLY	ALP-G315	LP Gauge (0-500 psi)
16	GAUGE ISOLATION	ALP-V301	LP Gauge Isolation Valve
<b>SUPPLY SELECTOR VALVE</b>			
17	SUPPLY SELECTOR VALVE	ALP-V302	Air Supply Selector Valve
<b>Relief Valves</b>			
18	N/A	ALP-V308	LP Relief Valve #1
19	N/A	ALP-V315	LP Relief Valve #2

SS500-HK-MMO-010

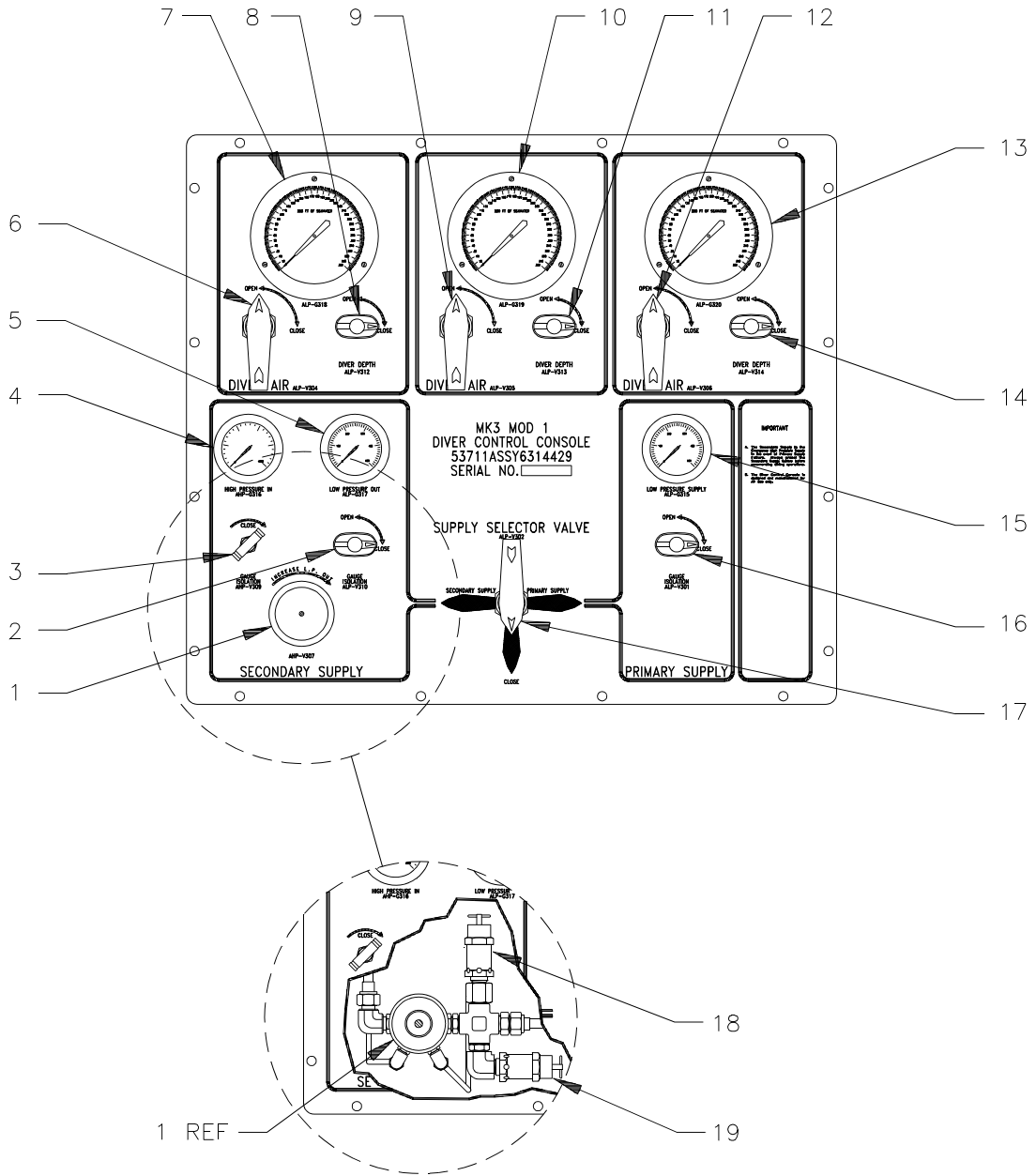


Figure B-3. LWDS MK 3 Mod 1 Control Console Assembly

## SS500-HK-MMO-010

**B.8 SCHEDULED/CORRECTIVE MAINTENANCE AND TROUBLESHOOTING**

Chapters 4, 5, and 6 of this manual provide scheduled maintenance, troubleshooting, and corrective maintenance procedures for the components that are common to both the Mod 0 and Mod 1 systems. Whenever possible, procedures for the components that are unique to the Mod 1 system have been incorporated into the applicable procedures in Chapters 4, 5, and 6. Refer to the following index to locate the applicable corrective maintenance procedures for Mod 1 components in Chapter 6:

- HP Pressure Gauge (AHP-G211) ..... Para. 6.8.4.8
- HP Pressure Gauge (AHP-G316) ..... Para. 6.8.5.10
- LP Relief Valve (ALP-V211) ..... Para. 6.8.4.6
- LP Relief Valve (ALP-V315) ..... Para. 6.8.5.7

Maintenance and troubleshooting procedures for the ASRA are located in the FADS III Air System Operation and Maintenance Manual, NAVSEA S9592-B1-MMO-010.

**B.9 PARTS LISTS**

Chapter 7 of this manual contains parts lists that may also be used when ordering parts for the LWDS MK 3 Mod 1; however, the following differences should be noted:

- Refer to Figure 7-18 when ordering the Mod 1 version of the HP pressure gauges AHP-G211 and AHP-G316, and note the following:
  - ❶ Pressure range of Mod 1 gauge is **0-6000 psig**
  - ❷ Part No. for the Mod 1 gauge is **25502-36H21-MBV**
  - ❸ NSN not available
- Refer to Figure 7-32 when ordering LP relief valves ALP-V211 and ALP-V315. These valves are identical to the Mod 0 valves and are simply used as additional valves to handle the higher pressure requirements of the Mod 1 system.
- Refer to Figure 7-16 when ordering the Mod 1 HP supply in-line air filter, and note the following:
  - ❶ Part No. for the Mod 1 air filter is **44-13GG10VN**
  - ❷ NSN not available

**B.10 INSTALLATION**

Refer to Chapter 8 of this manual for information and procedures regarding the initial inventory, inspection, testing, and storage of the LWDS MK 3 Mod 0. The procedures in Chapter 8 can also be used for the components that are common to both the Mod 0 and the Mod 1. Modification kits for upgrading the LWDS MK 3 Mod 0 to a Mod 1 are available upon request from NAVSEA 00C at the address on the following page.

## SS500-HK-MMO-010

COMMANDER  
 NAVAL SEA SYSTEMS COMMAND  
 ATTN 00C33  
 1333 ISAAC HULL AVENUE SE STOP 1073  
 WASHINGTON NAVY YARD DC 20376-1073

## **B.11 OPERATING AND EMERGENCY PROCEDURES**

The Operating Procedures (OPs) and Emergency Procedures (EPs) for the LWDS are numbered in consecutive order throughout this manual. The OPs for the Mod 0 (OP-1 thru OP-7) are contained in Appendix A, and the OPs for the Mod 1 (OP-8 through OP-11) are included in this appendix. Although the emergency procedure for the Mod 0 is basically the same as that for the Mod 1, two separate procedures have been provided for ease of reference. EP-1 is provided in Appendix A for the Mod 0, and Appendix B contains EP-2 for the Mod 1. Table B-6 contains an index of the OPs and EP provided in this appendix, and Figure B-4 shows the general sequence of operating procedures for the LWDS MK 3 Mod 1.

**Table B-6. Index of LWDS MK 3 Mod 1 Operating and Emergency Procedures**

Procedure No.	Title	Page No.
OP-8	LWDS MK 3 Mod 1 Permission Setup Procedures	B-13
OP-9	LWDS MK 3 Mod 1 Pre-dive Start-Up Procedures	B-19
OP-9M	LWDS MK 3 Mod 1 Modified Pre-dive Start-Up Procedures	B-25
OP-10	LWDS MK 3 Mod 1 Post-dive Shutdown Procedures	B-29
OP-10M	LWDS MK 3 Mod 1 Modified Post-dive Shutdown Procedures	B-33
OP-11	LWDS MK 3 Mod 1 Post-mission Procedures	B-35
EP-2	LWDS MK 3 Mod 1 Emergency Procedure: Loss of Primary Air	B-39

The OPs and EPs in Appendices A and B are provided in the form of checklists that can be reproduced for use in verifying the performance of the procedures. Unlike the OPs in Appendix A, however, the OPs in this appendix contain full procedural steps and therefore require no accompanying table. The following information covers the elements of each checklist and indicates what type of action, if any, is required:

- a. **DATE:** Checker fills in current date in acceptable format.
- b. **NOTE 1:** Contains a reminder to record notes and deficiencies in REMARKS section at end of each OP or EP.

## SS500-HK-MMO-010

- c. **STEP:** Numbers in this column indicate step numbers in consecutive order.
- d. **COMPONENT:** Column contains nomenclature for component(s) involved in each step.
- e. **DESCRIPTION:** Column contains valve and hose numbers (if applicable) of component(s) involved and any other information that may be helpful.
- f. **PROCEDURE:** Column describes actions to be performed by appropriate personnel. Checker verifies actions and fills in blanks or circles choices as appropriate.
- g. **LOCATION:** Column contains name of assembly where referenced component is located.
- h. **CHECK:** Checker initials this column as each step is completed.
- i. **REF:** Checker places a mark in this column to indicate that a note has been included in REMARKS section at end of procedure.
- j. **REMARKS:** Checker uses this section to document any deficiencies or problems found during performance of a particular step. Checker should begin each note with step number involved.
- k. **Signature block:** Checker prints and signs name, and diving supervisor signs to verify that all actions have been performed and all deficiencies and problems have been noted.

**NOTE**

The following acronyms are used in the LWDS MK 3 Mod 1 OPs:

ASRA	Air Supply Rack Assembly
CCA	Control Console Assembly
HPAC	HP Air Compressor
TL	Transfer Lock
TRC	Transportable Recompression Chamber
TRCS	Transportable Recompression Chamber System
VTA	Volume Tank Assembly

SS500-HK-MMO-010

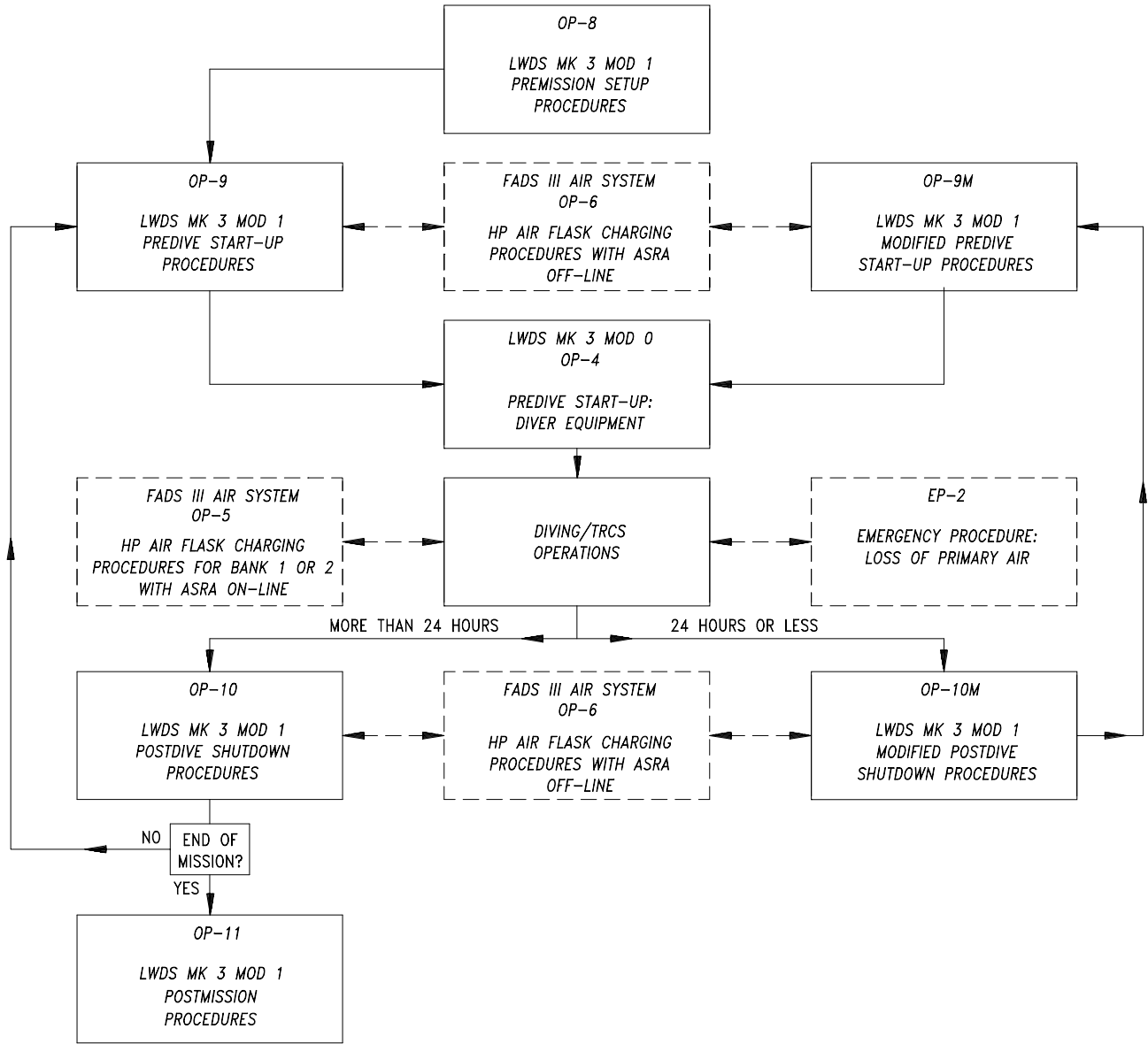


Figure B-4. LWDS MK 3 Mod 1 Operating and Emergency Procedures Flow Chart



THIS PAGE INTENTIONALLY LEFT BLANK

## SS500-HK-MMO-010

OP-8 LWDS MK 3 MOD 1 PREMISSION SETUP PROCEDURES						
DATE: _____						
NOTE 1: Record notes and deficiencies in section provided at the end of this operating procedure.						
STEP	COMPONENT	DESCRIPTION	PROCEDURE	LOCATION	CHECK	REF
<div style="border: 1px solid black; padding: 5px; width: fit-content; margin: 0 auto;"><b>WARNING</b></div> <p><b>Adequately position, stabilize, and secure all equipment prior to operation as movement during operation could result in equipment damage and injury or death to personnel.</b></p>						
N/A	All Assemblies	N/A	Position all assemblies within reach of interface hoses (40 feet maximum).	ASRA VTA CCA HPAC		
PART I - AIR SUPPLY RACK ASSEMBLY (ASRA) SETUP PROCEDURE						
1	ASRA Doors	N/A	Open.	ASRA		
2	ASRA	N/A	Inspect assembly and individual flasks, valves, gauges, and hoses for damage. Replace components as required.	ASRA		
3	Scuba Charge Hose Assembly	H-406	Ensure scuba yoke installed on yoke bracket.	ASRA		
4	Air Supplies	N/A	Identify ports and banks to be used for primary, secondary, and back-up air supplies and record on first page of OP-9.	ASRA		
<div style="border: 1px solid black; padding: 5px; width: fit-content; margin: 0 auto;"><b>WARNING</b></div> <p><b>The PRIMARY and SECONDARY tags must remain affixed to the assigned PORT A, PORT B, and PORT C valve handles on the ASRA as the removal or swapping of tags can result in personnel injury or death.</b></p>						
5	<b>PORT A</b> and/or <b>PORT B</b> Valve	AHP-V443 and/or AHP-V429	Hang PRIMARY tag on primary port valve(s) and circle below: <b>A</b> and/or <b>B</b>	ASRA		
6	<b>PORT C</b> Valve	AHP-V422	Tag with SECONDARY tag.	ASRA		
7	All ASRA Valves	As Assigned	Ensure closed (fully CW).	ASRA		

## SS500-HK-MMO-010

OP-8 LWDS MK 3 MOD 1 PREMISSION SETUP PROCEDURES—Continued						
STEP	COMPONENT	DESCRIPTION	PROCEDURE	LOCATION	CHECK	REF
<b>PART I - AIR SUPPLY RACK ASSEMBLY (ASRA) SETUP PROCEDURE—Continued</b>						
8	<b>SCUBA PRESSURE Regulator</b>	AHP-V432	Ensure fully backed off (CCW).	ASRA		
9	ASRA Doors	N/A	Close and latch; keep doors closed until ready for use.	ASRA		
<div style="border: 1px solid black; padding: 5px; width: fit-content; margin: 0 auto;"><b>WARNING</b></div> <p><b>Because the FADS III ASRA is capable of being pressurized to 5,000 psi, the ASRA must be connected only to volume tank and control console assemblies that have been modified for 5,000 psi service. Connection to an unmodified assembly can result in equipment damage and personnel injury or death.</b></p>						
<b>PART II - VOLUME TANK ASSEMBLY (VTA) SETUP PROCEDURE</b>						
1	VTA Cover	N/A	Remove.	VTA		
2	VTA	N/A	Inspect assembly and individual valves and gauges for damage. Replace components as required.	VTA		
3	VTA Side Tables	N/A	Insert side tables and secure with lockpins.	VTA		
4	CCA Platform	N/A	Place CCA platform on VTA frame and secure with lockpins.	VTA		
5	Regulator Gauge Isolation Gauge Isolation Drain Valve Drain Valve Drain Valve LP Air Out	AHP-V201 AHP-V202 ALP-V204 ALP-V205 ALP-V208 ALP-V209 ALP-V210	Ensure closed or unloaded.	VTA		
<b>PART III - CONTROL CONSOLE ASSEMBLY (CCA) SETUP PROCEDURE</b>						
1	CCA Cover	N/A	Depress breather valves. Remove cover.	CCA		
2	CCA	N/A	Inspect assembly and individual valves and gauges for damage. Replace components as required.	CCA		
3	CCA Support Arms	N/A	Open rear panel. Insert support arms with pegs bent to rear of console and set unit on platform above VTA; pin in place.	CCA		

## SS500-HK-MMO-010

OP-8 LWDS MK 3 MOD 1 PREMISSION SETUP PROCEDURES—Continued						
STEP	COMPONENT	DESCRIPTION	PROCEDURE	LOCATION	CHECK	REF
<b>PART III - CONTROL CONSOLE ASSEMBLY (CCA) SETUP PROCEDURE—Continued</b>						
4	Gauge Isolation Supply Selector Diver Air (R) Diver Air (G) Diver Air (Y) Regulator Gauge Isolation Gauge Isolation Diver Depth (R) Diver Depth (G) Diver Depth (Y)	ALP-V301 ALP-V302 ALP-V304 ALP-V305 ALP-V306 AHP-V307 AHP-V309 ALP-V310 ALP-V312 ALP-V313 ALP-V314	Ensure closed or unloaded.	CCA		
<b>NOTE 2:</b> When interfacing with the TRCS, omit Parts IV and V of this OP and connect the primary and secondary HP air supply hoses in accordance with OP-8 in Appendix A of the FADS III Air System manual (NAVSEA S9592-B1-MMO-010).						
<b>PART IV - CONNECTING PRIMARY HP AIR SUPPLY HOSE</b>						
<div style="border: 1px solid black; padding: 5px; display: inline-block; margin-bottom: 10px;"><b>WARNINGS</b></div> <p><b>Failure to connect hose assembly strain reliefs can cause personal injury or death should the hose separate or burst.</b></p> <p><b>Ports A, B, and C on the ASRA must be depressurized whenever a port cap or hose is removed from a port connector. Removal of a port cap or hose when supply piping is pressurized can result in injury or death.</b></p> <p><b>Fittings must be properly tightened and O-rings must be properly seated when connecting hoses. Fittings and O-rings that are not properly installed can allow HP air to escape and result in injury or death. Excessive tightening can damage threads.</b></p>						
1	HP Air Hose Assembly	H-436	Remove from ASRA door. Inspect for cuts and abrasions.	ASRA		
2	<b>PORT A</b> or <b>PORT B</b> BLEED Valve	AHP-V442 or AHP-V441	Open valve that corresponds to port where H-436 will be connected.	ASRA		
3	HP Air Hose Assembly	H-436 to PORT A - HP or PORT B - HP	Remove port cap from PORT A - HP or PORT B - HP and check for damaged threads. Remove plug from hose and check hose fitting for damaged O-ring and threads. Connect hose, and tighten 3/8 to 1/2 turn after O-ring has engaged. Connect strain relief. Circle one: <b>A</b> or <b>B</b>	ASRA		

## SS500-HK-MMO-010

OP-8 LWDS MK 3 MOD 1 PREMISSION SETUP PROCEDURES—Continued						
STEP	COMPONENT	DESCRIPTION	PROCEDURE	LOCATION	CHECK	REF
<b>PART IV - CONNECTING PRIMARY HP AIR SUPPLY HOSE—Continued</b>						
4	HP Air Hose Assembly	H-436 to VTA	Remove port cap from volume tank and check for damaged threads. Connect hose, and tighten 3/8 to 1/2 turn after O-ring has engaged. Connect strain relief.	VTA		
5	<b>PORT A</b> or <b>PORT B</b> BLEED Valve	AHP-V442 or AHP-V441	Close valve that was opened in Step 2.	ASRA		
<b>PART V - CONNECTING SECONDARY HP AIR SUPPLY HOSE</b>						
1	HP Air Hose Assembly	H-436	Remove from ASRA door. Inspect for cuts and abrasions.	ASRA		
2	<b>PORT C</b> BLEED Valve	AHP-V440	Open.	ASRA		
3	HP Air Hose Assembly	H-436 to PORT C - HP	Remove port cap from PORT C - HP and check for damaged threads. Remove plug from hose and check hose fitting for damaged O-ring and threads. Connect hose, and tighten 3/8 to 1/2 turn after O-ring has engaged. Connect strain relief.	ASRA		
4	HP Air Hose Assembly	H-436 to CCA	Remove port cap from <b>SECONDARY SUPPLY</b> bulkhead connector and check for damaged threads. Remove plug from hose and check hose fitting for damaged O-ring and threads. Connect hose, and tighten 3/8 to 1/2 turn after O-ring has engaged. Connect strain relief.	CCA		
5	<b>PORT C</b> BLEED Valve	AHP-V440	Close.	ASRA		
<b>PART VI - CONNECTING LP AIR SUPPLY HOSE</b>						
1	LP Air Hose Assembly	H-101	Inspect for cuts and abrasions.	VTA CCA		
2	LP Air Hose Assembly	H-101	Remove cap from volume tank <b>LP AIR OUT</b> bulkhead connector and plug from one end of hose; check for damaged threads.	VTA		

## SS500-HK-MMO-010

OP-8 LWDS MK 3 MOD 1 PREMISSION SETUP PROCEDURES—Continued						
STEP	COMPONENT	DESCRIPTION	PROCEDURE	LOCATION	CHECK	REF
<b>PART VI - CONNECTING LP AIR SUPPLY HOSE—Continued</b>						
3	LP Air Hose Assembly	H-101	Connect hose to volume tank <b>LP AIR OUT</b> bulkhead connector. Secure safety cable to volume tank tiedown rings. Connect male to female protective plug and cap.	VTA		
4	LP Air Hose Assembly	H-101	Remove cap from control console <b>PRIMARY SUPPLY</b> bulkhead connector and plug from free end of hose; check for damaged threads.	CCA		
5	LP Air Hose Assembly	H-101	Connect hose to control console <b>PRIMARY SUPPLY</b> bulkhead connector. Secure safety cable to volume tank frame. Connect male to female protective plug and cap.	CCA		
<b>PART VII - HP AIR COMPRESSOR (HPAC) SETUP</b>						
N/A	HPAC	N/A	Prepare in accordance with compressor operation and maintenance manual and PMS.	HPAC		
<b>PART VIII - MISCELLANEOUS SETUP</b>						
<div style="border: 1px solid black; padding: 5px; display: inline-block; margin-bottom: 10px;"><b>WARNING</b></div> <p><b>Adequately position, stabilize, and secure all equipment prior to operation as movement during operation could result in equipment damage and injury or death to personnel.</b></p>						
1	All Assemblies	N/A	Secure equipment in place.	VTA CCA ASRA HPAC		
2	Maintenance box	N/A	Inventory contents and replenish as necessary.	Dive Site		
3	Consumables	N/A	Ensure ample materials at dive site.	Dive Site		
<b>NOTE 3:</b> Proceed to OP-9, <i>LWDS MK 3 Mod 1 Pre-dive Start-Up Procedures</i> .						



## SS500-HK-MMO-010

OP-9 LWDS MK 3 MOD 1 PREDIVE START-UP PROCEDURES						
DATE: _____						
NOTE 1: Record notes and deficiencies in section provided at the end of this operating procedure.						
STEP	COMPONENT	DESCRIPTION	PROCEDURE	LOCATION	CHECK	REF
<p><b>PRELIMINARY STEP A:</b> This step applies only when the ASRA is used with any air diving system other than the TRCS. Banks 1 and 2 can be selected together or separately to serve as the active bank for Port A or B. Designate which of the following banks will be used for the primary supply and which will be used for the back-up supply (if any):</p> <p>Bank 1 - Primary Back-Up  Bank 2 - Primary Back-Up  Bank 3 - Always supplies secondary air to CCA</p> <p>Circle the port chosen to supply primary air to the VTA:  Port A Port B</p> <p>Note: Port C always supplies secondary air to CCA.</p>						
<p><b>PRELIMINARY STEP B:</b> This step applies only when the ASRA is used with the TRCS. When interfacing with the TRCS, Banks 1 and 2 must be aligned separately.</p> <p>Designate which bank has been chosen as primary to TRCS and which has been chosen as primary to CCA by circling the appropriate label:</p> <p>Bank 1 - Primary to TRCS Primary to CCA  Bank 2 - Primary to TRCS Primary to CCA  Bank 3 - Always supplies secondary air to Port C</p> <p>Designate which port has been chosen as primary to TRCS and which has been chosen as primary to CCA by circling the appropriate label:</p> <p>Port A - Primary to TRCS Primary to CCA  Port B - Primary to TRCS Primary to CCA  Port C - Always supplies secondary air to CCA and TRCS</p>						
PART I - AIR SUPPLY RACK ASSEMBLY (ASRA) START-UP PROCEDURE						
1	ASRA Doors	N/A	Open.	ASRA		
2	<b>GAUGE STOP</b> Valves	AHP-V426 AHP-V427 AHP-V428	Open.	ASRA		
3	<b>FLASK ISOLATION</b> Valves	AHP-V401 AHP-V402 AHP-V403 AHP-V404 AHP-V405 AHP-V406	Open slowly.	ASRA		



## SS500-HK-MMO-010

OP-9 LWDS MK 3 MOD 1 PREDIVE START-UP PROCEDURES—Continued						
STEP	COMPONENT	DESCRIPTION	PROCEDURE	LOCATION	CHECK	REF
<b>PART I - AIR SUPPLY RACK ASSEMBLY (ASRA) START-UP PROCEDURE—Continued</b>						
3 Cont	<b>FLASK ISOLATION</b> Valves	AHP-V407 AHP-V408 AHP-V409	Open slowly.	ASRA		
4	<b>BANK 1</b> Gauge	AHP-G437	Record pressure (min 2,800 psi):  _____ psig	ASRA		
	<b>BANK 2</b> Gauge	AHP-G438	Record pressure (min 2,800 psi):  _____ psig	ASRA		
	<b>BANK 3</b> Gauge	AHP-G439	Record pressure (min 2,800 psi):  _____ psig	ASRA		
<b>NOTE 2:</b> If any bank does not have enough pressure for the required dive, charge in accordance with OP-6 in Appendix A of the FADS III Air System manual (NAVSEA S9592-B1-MMO-010).						
5	<b>SYSTEM DRAIN</b> Valve	AHP-V419	Open.	ASRA		
6	<b>FLASK DRAIN</b> Valves	AHP-V410 AHP-V411 AHP-V412 AHP-V413 AHP-V414 AHP-V415 AHP-V416 AHP-V417 AHP-V418	Open, allow to drain, and close.	ASRA		
7	<b>SYSTEM DRAIN</b> Valve	AHP-V419	Close.	ASRA		
8	<b>MANIFOLD</b> Valve	AHP-V444	Open unless diving with TRCS.	ASRA		
<b>PART II - SECONDARY HP AIR SUPPLY START-UP PROCEDURE</b>						
1	<b>GAUGE ISOLATION</b> Valves	AHP-V309 ALP-V310	Open.	CCA		
2	Manual Adjust Regulator	AHP-V307	Ensure unloaded (fully CCW).	CCA		
<b>NOTE 3:</b> When interfacing with TRCS, ensure TRC OP-1 is complete to step 94 and Transfer Lock (TL) OP-2 is complete to step 67 before supplying pressure.						
3	<b>PORT C</b> Valve	AHP-V422	Open slowly.	ASRA		

## SS500-HK-MMO-010

OP-9 LWDS MK 3 MOD 1 PREDIVE START-UP PROCEDURES—Continued						
STEP	COMPONENT	DESCRIPTION	PROCEDURE	LOCATION	CHECK	REF
<b>PART II - SECONDARY HP AIR SUPPLY START-UP PROCEDURE—Continued</b>						
4	<b>HIGH PRESSURE IN</b> Gauge	AHP-G316	Record pressure (max 5,000 psi):  _____ psig	CCA		
<b>NOTE 4: Diving Supervisor:</b> Determine minimum manifold pressure and record here: _____						
5	Manual Adjust Regulator	AHP-V307	Increase low pressure out as directed by diving supervisor. Record pressure at ALP-G317.  _____ psig	CCA		
6	<b>SUPPLY SELECTOR</b> Valve	ALP-V302	Turn to <b>SECONDARY SUPPLY</b> .	CCA		
7	<b>DIVER AIR</b> Bulkhead Connectors	N/A	Ensure uncapped.	CCA		
8	<b>DIVER AIR</b> Valves	ALP-V304 ALP-V305 ALP-V306	Open, confirm full flow, and close.	CCA		
9	<b>SUPPLY SELECTOR</b> Valve	ALP-V302	Switch to <b>CLOSE</b> .	CCA		
<b>PART III - PRIMARY HP AIR SUPPLY START-UP PROCEDURE</b>						
<b>NOTE 5:</b> Ensure that the ASRA port and bank designations determined during premission setup and recorded on page 1 of this OP are applicable to the current dive or operation. If not, return to Part I, Step 4 of OP-8 and determine new designations.						
<b>NOTE 6:</b> If Banks 1 and 2 are selected together, perform steps 1 thru 16. If only Bank 1 is selected, perform step 1 and then steps 3 thru 16. If only Bank 2 is selected, perform steps 2 thru 16.						
1	<b>BANK 1 MANIFOLD</b> Valve	AHP-V420	Open only if Bank 1 is used as primary bank or if Banks 1 and 2 are used together.	ASRA		
2	<b>BANK 2 MANIFOLD</b> Valve	AHP-V421	Open only if Bank 2 is used as primary bank or if Banks 1 and 2 are used together.	ASRA		
3	<b>GAUGE ISOLATION</b> Valves	AHP-V202 ALP-V204	Open.	VTA		
4	Manual Adjust Regulator	AHP-V201	Ensure unloaded (fully CCW).	VTA		

## SS500-HK-MMO-010

OP-9 LWDS MK 3 MOD 1 PREDIVE START-UP PROCEDURES—Continued						
STEP	COMPONENT	DESCRIPTION	PROCEDURE	LOCATION	CHECK	REF
<b>PART III - PRIMARY HP AIR SUPPLY START-UP PROCEDURE—Continued</b>						
<b>NOTE 7:</b> When interfacing with TRCS, ensure TRC OP-1 is complete to step 92 and TL OP-2 is complete to step 66 before supplying pressure.						
5	<b>LP AIR OUT</b> Valve	ALP-V210	Ensure closed.	VTA		
6	<b>PORT A</b> or <b>PORT B</b> Valve	AHP-V443 or AHP-V429	Open slowly. Circle port that was opened for primary: <b>A</b> or <b>B</b>	ASRA		
7	<b>HP SUPPLY PRESSURE</b> Gauge	AHP-G211	Record pressure (max 5,000 psi): _____ psig	VTA		
<b>NOTE 8:</b> For the following step, refer to minimum manifold pressure recorded in Note 4 of this OP.						
8	Manual Adjust Regulator	AHP-V201	Increase low pressure out as directed by diving supervisor (do not exceed 250 psi). Record pressure at ALP-G212. _____ psig	VTA		
9	Drain Valve	ALP-V208	Open, allow moisture to drain, and close.	VTA		
10	<b>GAUGE ISOLATION</b> Valve	ALP-V301	Open.	CCA		
11	<b>DIVER AIR/ DIVER DEPTH</b> Bulkhead Connectors	N/A	Ensure uncapped.	CCA		
12	<b>LP AIR OUT</b> Valve	ALP-V210	Open slowly to pressurize control console.	VTA		
13	<b>LOW PRESSURE SUPPLY</b> Gauge	ALP-G315	Record pressure: _____ psig	CCA		
14	<b>SUPPLY SELECTOR</b> Valve	ALP-V302	Switch to <b>PRIMARY SUPPLY</b> .	CCA		
15	<b>DIVER AIR</b> Valves	ALP-V304 ALP-V305 ALP-V306	Open, confirm full flow, and close.	CCA		

## SS500-HK-MMO-010

OP-9 LWDS MK 3 MOD 1 PREDIVE START-UP PROCEDURES—Continued						
STEP	COMPONENT	DESCRIPTION	PROCEDURE	LOCATION	CHECK	REF
<b>PART III - PRIMARY HP AIR SUPPLY START-UP PROCEDURE—Continued</b>						
<div style="border: 1px solid black; padding: 5px; width: fit-content; margin: 0 auto;"> <b>WARNING</b> </div> <p><b>DO NOT FULLY OPEN DIVER DEPTH VALVES (ALP-V312, ALP-V313, and ALP-V314). Failure to comply will damage the diver depth gauges and may cause injury to personnel.</b></p>						
16	<b>DIVER DEPTH</b> Valves	ALP-V312 ALP-V313 ALP-V314	Open <b>slightly</b> , confirm flow, and close.	CCA		
<p><b>NOTE 9:</b> Conduct prediver start-up of diver equipment in accordance with OP-4 in Appendix A of this manual and observe Notes 10 thru 13 below.</p> <p><b>NOTE 10:</b> If primary supply pressure drops below minimum manifold pressure during the dive, proceed immediately to EP-2, <i>LWDS MK 3 Mod 1 Emergency Procedure: Loss of Primary Air</i>.</p> <p><b>NOTE 11:</b> When primary bank pressure drops to 1,000 psi during operations, shift to back-up bank by closing primary bank manifold valve and opening back-up bank manifold valve. Tag back-up bank manifold valve with PRIMARY tag.</p> <p><b>NOTE 12:</b> If flasks require charging during the dive, refer to OP-5 in Appendix A of the FADS III Air System manual (NAVSEA S9592-B1-MMO-010).</p> <p><b>NOTE 13:</b> Upon completion of the dive, proceed to the appropriate Mod 1 postdive shutdown procedure in OP-10 or OP-10M.</p>						
<p><b>REMARKS:</b> (Using step number as a reference, list any deficiencies or problems found during performance of this procedure.)</p> <hr/> <hr/> <hr/> <hr/> <hr/> <hr/>						
<p>Performed By: _____ Printed Name and Signature</p> <p>Noted and Checked By: _____ Diving Supervisor's Signature</p>						

THIS PAGE INTENTIONALLY LEFT BLANK

## SS500-HK-MMO-010

OP-9M						
LWDS MK 3 MOD 1 MODIFIED PREDIVE START-UP PROCEDURES						
DATE: _____						
<b>NOTE 1:</b> Record notes and deficiencies in section provided at the end of this operating procedure.						
<b>NOTE 2:</b> This OP may be performed only if the modified postdive shutdown procedures in OP-10M were conducted during the last shutdown and 24 hours or less have elapsed; otherwise, the prediver start-up procedures in OP-9 must be conducted.						
<b>NOTE 3:</b> Ensure that the ASRA port and bank designations determined during premission setup and recorded on page 1 of OP-9 are applicable to the current dive or operation. If not, return to Part I, Step 4 of OP-8 and determine new designations.						
<b>NOTE 4:</b> Ensure umbilicals are still connected to <b>DIVER AIR</b> and <b>DIVER DEPTH</b> bulkhead connectors.						
STEP	COMPONENT	DESCRIPTION	PROCEDURE	LOCATION	CHECK	REF
PART I - AIR SUPPLY RACK ASSEMBLY (ASRA) MODIFIED START-UP PROCEDURE						
1	ASRA Doors	N/A	Open.	ASRA		
2	<b>FLASK ISOLATION</b> Valves	AHP-V401 AHP-V402 AHP-V403 AHP-V404 AHP-V405 AHP-V406 AHP-V407 AHP-V408 AHP-V409	Ensure open.	ASRA		
3	<b>BANK 1</b> Gauge	AHP-G437	Record pressure (min 2,800 psi): _____ psig	ASRA		
4	<b>BANK 2</b> Gauge	AHP-G438	Record pressure (min 2,800 psi): _____ psig	ASRA		
5	<b>BANK 3</b> Gauge	AHP-G439	Record pressure (min 2,800 psi): _____ psig	ASRA		
<b>NOTE 5:</b> If any bank does not have enough pressure for the required dive, charge in accordance with OP-6 in Appendix A of the FADS III Air System manual (NAVSEA S9592-B1-MMO-010).						
6	<b>MANIFOLD</b> Valve	AHP-V444	Open unless diving with TRCS.	ASRA		
PART II - SECONDARY HP AIR SUPPLY MODIFIED START-UP PROCEDURE						
1	Manual Adjust Regulator	AHP-V307	Ensure unloaded (fully CCW).	CCA		
<b>NOTE 6:</b> When interfacing with TRCS, ensure TRC OP-1 is complete to step 94 and Transfer Lock (TL) OP-2 is complete to step 67 before supplying pressure.						

## SS500-HK-MMO-010

OP-9M LWDS MK 3 MOD 1 MODIFIED PREDIVE START-UP PROCEDURES—Continued						
STEP	COMPONENT	DESCRIPTION	PROCEDURE	LOCATION	CHECK	REF
<b>PART II - SECONDARY HP AIR SUPPLY MODIFIED START-UP PROCEDURE—Continued</b>						
2	<b>PORT C Valve</b>	AHP-V422	Open slowly.	ASRA		
3	<b>HIGH PRESSURE IN Gauge</b>	AHP-G316	Record pressure (max 5,000 psi): _____ psig	CCA		
<b>NOTE 7: Diving Supervisor:</b> Determine minimum manifold pressure and record here: _____						
4	Manual Adjust Regulator	AHP-V307	Increase low pressure out as directed by diving supervisor. Record pressure at ALP-G317: _____ psig	CCA		
5	<b>SUPPLY SELECTOR Valve</b>	ALP-V302	Switch to <b>SECONDARY SUPPLY.</b>	CCA		
6	<b>DIVER AIR Valves</b>	ALP-V304 ALP-V305 ALP-V306	Open, confirm full flow, and close.	CCA		
7	<b>SUPPLY SELECTOR Valve</b>	ALP-V302	Switch to <b>CLOSE.</b>	CCA		
<b>PART III - PRIMARY HP AIR SUPPLY MODIFIED START-UP PROCEDURE</b>						
<b>NOTE 8:</b> Review ASRA port and bank designations to determine which of the following two steps are applicable.						
<b>NOTE 9:</b> If Banks 1 and 2 are selected together, perform steps 1 thru 13. If only Bank 1 is selected, perform step 1 and then steps 3 thru 13. If only Bank 2 is selected, perform steps 2 thru 13.						
1	<b>BANK 1 MANIFOLD Valve</b>	AHP-V420	Open only if Bank 1 is used as primary bank or if Banks 1 and 2 are used together.	ASRA		
2	<b>BANK 2 MANIFOLD Valve</b>	AHP-V421	Open only if Bank 2 is used as primary bank or if Banks 1 and 2 are used together.	ASRA		
3	Manual Adjust Regulator	AHP-V201	Ensure unloaded (fully CCW).	VTA		
<b>NOTE 10:</b> When interfacing with TRCS, ensure TRC OP-1 is complete to step 92 and TL OP-2 is complete to step 66 before supplying pressure.						
4	<b>LP AIR OUT Valve</b>	ALP-V210	Ensure closed.	VTA		

## SS500-HK-MMO-010

OP-9M						
LWDS MK 3 MOD 1 MODIFIED PREDIVE START-UP PROCEDURES—Continued						
STEP	COMPONENT	DESCRIPTION	PROCEDURE	LOCATION	CHECK	REF
<b>PART III - PRIMARY HP AIR SUPPLY MODIFIED START-UP PROCEDURE—Continued</b>						
5	<b>PORT A</b> or <b>PORT B</b> Valve	AHP-V443 or AHP-V429	Open slowly. Circle port that was opened for primary: <b>A</b> or <b>B</b>	ASRA		
6	<b>HP SUPPLY PRESSURE</b> Gauge	AHP-G211	Record pressure (max 5,000 psi):  _____ psig	VTA		
<b>NOTE 11:</b> For the following step, refer to minimum manifold pressure recorded in Note 7 of this OP.						
7	Manual Adjust Regulator	AHP-V201	Increase low pressure out as directed by diving supervisor (do not exceed 250 psi). Record pressure at ALP-G212.  _____ psig	VTA		
8	Drain Valve	ALP-V208	Open, allow moisture to drain, and close.	VTA		
9	<b>LP AIR OUT</b> Valve	ALP-V210	Open slowly to pressurize control console.	VTA		
10	<b>LOW PRESSURE SUPPLY</b> Gauge	ALP-G315	Record pressure:  _____ psig	CCA		
11	<b>SUPPLY SELECTOR</b> Valve	ALP-V302	Switch to <b>PRIMARY SUPPLY</b> .	CCA		
12	<b>DIVER AIR</b> Valves	ALP-V304 ALP-V305 ALP-V306	Open, ensure full flow, and close.	CCA		
<div style="border: 1px solid black; padding: 5px; width: fit-content; margin: 0 auto;"><b>WARNING</b></div> <p><b>DO NOT FULLY OPEN DIVER DEPTH VALVES (ALP-V312, ALP-V313, AND ALP-V314). Failure to comply will damage to the diver depth gauges and may cause injury to personnel.</b></p>						
13	<b>DIVER DEPTH</b> Valves	ALP-V312 ALP-V313 ALP-V314	Open <b>slightly</b> , confirm flow, and close.	CCA		
<b>NOTE 12:</b> Conduct prediv start-up of diver equipment in accordance with OP-4 in Appendix A of this manual and observe Notes 13 thru 16 on the following page.						





## SS500-HK-MMO-010

OP-10 LWDS MK 3 MOD 1 POSTDIVE SHUTDOWN PROCEDURES						
DATE: _____						
<b>NOTE 1:</b> Record notes and deficiencies in section provided at the end of this operating procedure.						
<b>NOTE 2:</b> This OP is used for short breaks that are expected to exceed 24 hours, and also is performed as part of the postmission procedures in OP-11. If diving operations are expected to continue within 24 hours, the modified postdive shutdown procedures in OP-10M may be used instead.						
<b>NOTE 3:</b> If diving supervisor determines that flasks need to be charged during postdive shutdown, charge flasks in accordance with OP-6 in Appendix A of the FADS III Air System manual (NAVSEA S9592-B1-MMO-010). Ensure valves are returned to previous settings prior to continuing this procedure or beginning the next one.						
STEP	COMPONENT	DESCRIPTION	PROCEDURE	LOCATION	CHECK	REF
1	<b>DIVER DEPTH</b> Valves	ALP-V312 ALP-V313 ALP-V314	Close.	CCA		
2	<b>FLASK ISOLATION</b> Valves	AHP-V408 AHP-V409	Close.	ASRA		
3	<b>SUPPLY SELECTOR</b> Valve	ALP-V302	Switch to <b>SECONDARY SUPPLY</b> .	CCA		
<div style="border: 2px solid black; padding: 5px; display: inline-block; margin: 10px auto; width: 100px;"> <b>WARNING</b> </div> <p style="text-align: center; margin-top: 20px;"><b>Before bleeding HP air, ensure all personnel are clear of area to avoid injury from flying debris. Operator must wear protective eye wear when bleeding system.</b></p>						
4	UBA Purge Button	N/A	Push UBA purge button. Bleed secondary system.	UBA Face Mask		
5	Manual Adjust Regulator	AHP-V307	Unload (CCW).	CCA		
6	<b>PORT C BLEED</b> Valve	AHP-V440	Open, allow to depressurize, and close.	ASRA		
7	<b>PORT C</b> Valve	AHP-V422	Close.	ASRA		
8	<b>SUPPLY SELECTOR</b> Valve	ALP-V302	Switch to <b>PRIMARY SUPPLY</b> .	CCA		
9	<b>LP AIR OUT</b> Valve	ALP-V210	Close.	VTA		

## SS500-HK-MMO-010

OP-10 LWDS MK 3 MOD 1 POSTDIVE SHUTDOWN PROCEDURES—Continued						
STEP	COMPONENT	DESCRIPTION	PROCEDURE	LOCATION	CHECK	REF
10	<b>FLASK ISOLATION</b> Valves	AHP-V401 AHP-V402 AHP-V403 AHP-V404 AHP-V405 AHP-V406 AHP-V407	Close.	ASRA		
11	Manual Adjust Regulator	AHP-V201	Unload (CCW).	VTA		
<div style="border: 1px solid black; padding: 5px; display: inline-block; margin: 10px auto; width: 100px;"> <b>WARNING</b> </div> <p style="text-align: center; margin-top: 20px;"><b>Before bleeding LP air, ensure all personnel are clear of area to avoid injury from flying debris. Operator must wear protective eye wear when bleeding system.</b></p>						
12	<b>PORT A BLEED</b> Valve	AHP-V442	Open, depressurize, and close.	ASRA		
13	<b>PORT B BLEED</b> Valve	AHP-V441	Open, depressurize, and close.	ASRA		
14	<b>PORT A</b> Valve	AHP-V443	Close.	ASRA		
15	<b>PORT B</b> Valve	AHP-V429	Close.	ASRA		
16	UBA Purge Button	N/A	Push UBA purge button. Bleed primary system.	UBA Face Mask		
17	<b>DIVER AIR</b> Valves	ALP-V304 ALP-V305 ALP-V306	Close.	CCA		
18	Final Filter Condensate Drain Valve	ALP-V209	Open, allow moisture to drain, and close.	VTA		
19	Volume Tank Drain Valve	ALP-V208	Open, allow moisture to drain, and close.	VTA		
20	<b>SUPPLY SELECTOR</b> Valve	ALP-V302	Switch to <b>CLOSE</b> .	CCA		
<p><b>NOTE 4:</b> If dive mission is complete, proceed to OP-11. If dive mission is not complete, perform all required steps in OP-9 prior to next dive.</p>						



THIS PAGE INTENTIONALLY LEFT BLANK

## SS500-HK-MMO-010

OP-10M LWDS MK 3 MOD 1 MODIFIED POSTDIVE SHUTDOWN PROCEDURES						
<b>DATE:</b> _____						
<b>NOTE 1:</b> Record notes and deficiencies in section provided at the end of this operating procedure.						
<b>NOTE 2:</b> This OP may be used any time the equipment will be used again within 24 hours. If it is anticipated that more than 24 hours will pass before using the equipment again, the postdive shutdown procedures in OP-10 must be performed instead.						
<b>NOTE 3:</b> If diving supervisor determines that flasks need to be charged during postdive shutdown, charge flasks in accordance with OP-6 in Appendix A of the FADS III Air System manual (NAVSEA S9592-B1-MMO-010). Ensure valves are returned to previous settings prior to continuing this procedure or beginning the next one.						
STEP	COMPONENT	DESCRIPTION	PROCEDURE	LOCATION	CHECK	REF
1	<b>DIVER AIR</b> Valves	ALP-V304 ALP-V305 ALP-V306	Ensure closed.	CCA		
2	<b>DIVER DEPTH</b> Valves	ALP-V312 ALP-V313 ALP-V314	Ensure closed.	CCA		
3	Manual Adjust Regulator	AHP-V307	Unload (CCW).	CCA		
4	<b>SUPPLY SELECTOR</b> Valve	ALP-V302	Switch to <b>CLOSE</b> .	CCA		
5	<b>LP AIR OUT</b> Valve	ALP-V210	Close.	VTA		
6	Manual Adjust Regulator	AHP-V201	Unload (CCW).	VTA		
7	Final Filter Condensate Drain Valve	ALP-V209	Open, allow moisture to drain, and close.	VTA		
8	Volume Tank Drain Valve	ALP-V208	Open, allow moisture to drain, and close.	VTA		
9	<b>BANK 1 MANIFOLD</b> Valve	AHP-V420	Close.	ASRA		
10	<b>BANK 2 MANIFOLD</b> Valve	AHP-V421	Close.	ASRA		
11	<b>PORT A</b> Valve	AHP-V443	Close.	ASRA		
12	<b>PORT B</b> Valve	AHP-V429	Close.	ASRA		



## SS500-HK-MMO-010

OP-11 LWDS MK 3 MOD 1 POSTMISSION PROCEDURES						
DATE: _____						
<b>NOTE 1:</b> Record notes and deficiencies in section provided at the end of this operating procedure.						
<b>NOTE 2:</b> Ensure OP-10 has been completed prior to performing the postmission procedures in this OP.						
STEP	COMPONENT	DESCRIPTION	PROCEDURE	LOCATION	CHECK	REF
PART I - PREPARING EQUIPMENT FOR HOSE DISCONNECTIONS						
1	All ASRA Valves	As Assigned	Ensure closed (fully CW).	ASRA		
2	<b>SCUBA PRESSURE</b> Regulator	AHP-V432	Ensure fully backed off (CCW).	ASRA		
3	Gauge Isolation Supply Selector Diver Air (R) Diver Air (G) Diver Air (Y) Regulator Gauge Isolation Gauge Isolation Diver Depth (R) Diver Depth (G) Diver Depth (Y)	ALP-V301 ALP-V302 ALP-V304 ALP-V305 ALP-V306 AHP-V307 AHP-V309 ALP-V310 ALP-V312 ALP-V313 ALP-V314	Ensure closed or unloaded.	CCA		
4	<b>GAUGE ISOLATION</b> Valve	ALP-V204	Open.	VTA		
5	Drain Valve	ALP-V208	Open, bleed volume tank to ~50 psi, and close.	VTA		
6	Diver Umbilicals	N/A	Disconnect umbilicals. Cap/bag as required.	CCA		
7	<b>GAUGE ISOLATION</b> Valve	ALP-V204	Close.	VTA		
8	Regulator Gauge Isolation Gauge Isolation Drain Valve Drain Valve Drain Valve LP Air Out	AHP-V201 AHP-V202 ALP-V204 ALP-V205 ALP-V208 ALP-V209 ALP-V210	Ensure closed or unloaded.	VTA		
<b>NOTE 3:</b> If TRCS has been used, omit Parts II and III and disconnect hoses in accordance with OP-8 in Appendix A of the FADS III Air System manual (NAVSEA S9592-B1-MMO-010).						



## SS500-HK-MMO-010

OP-11 LWDS MK 3 MOD 1 POSTMISSION PROCEDURES—Continued						
STEP	COMPONENT	DESCRIPTION	PROCEDURE	LOCATION	CHECK	REF
<b>PART II - DISCONNECTING SECONDARY HP AIR SUPPLY HOSE</b>						
<div style="border: 1px solid black; padding: 5px; width: fit-content; margin: 0 auto;"><b>WARNING</b></div> <p style="text-align: center; margin-top: 20px;">Ports A, B, and C on the ASRA must be depressurized whenever a port cap or hose is removed from a port connector. Removal of a port cap or hose when supply piping is pressurized can result in injury or death.</p> <div style="border: 1px solid black; padding: 5px; width: fit-content; margin: 0 auto;"><b>CAUTION</b></div> <p style="text-align: center; margin-top: 20px;">Tighten hose fittings and port caps to proper torque as excessive tightening can damage threads.</p>						
1	<b>PORT C BLEED Valve</b>	AHP-V440	Open.	ASRA		
2	HP Air Hose Assembly	H-436 to <b>PORT C - HP</b>	Disconnect from ASRA <b>PORT C - HP</b> . Disconnect strain relief. Install port cap, and tighten 3/8 to 1/2 turn after O-ring engages. Install hose plug.	ASRA		
3	<b>PORT C BLEED Valve</b>	AHP-V440	Close.	ASRA		
4	HP Air Hose Assembly	H-436 to CCA	Disconnect from control console <b>SECONDARY SUPPLY</b> bulkhead connector. Disconnect strain relief. Install port cap, and tighten 3/8 to 1/2 turn after O-ring engages. Install hose plug.	CCA		
<b>PART III - DISCONNECTING PRIMARY HP AIR SUPPLY HOSE</b>						
1	<b>PORT A or PORT B BLEED Valve</b>	AHP-V442 or AHP-V441	Open valve that corresponds to port where H-436 is connected.	ASRA		
2	HP Air Hose Assembly	H-436 to <b>PORT A - HP or PORT B - HP</b>	Disconnect from ASRA <b>PORT A - HP or PORT B - HP</b> . Disconnect strain relief. Install port cap, and tighten 3/8 to 1/2 turn after O-ring engages. Install hose plug.	ASRA		
3	<b>PORT A or PORT B BLEED Valve</b>	AHP-V442 or AHP-V441	Close valve that was opened in step 1.	ASRA		

## SS500-HK-MMO-010

OP-11 LWDS MK 3 MOD 1 POSTMISSION PROCEDURES—Continued						
STEP	COMPONENT	DESCRIPTION	PROCEDURE	LOCATION	CHECK	REF
<b>PART III - DISCONNECTING PRIMARY HP AIR SUPPLY HOSE—Continued</b>						
4	HP Air Hose Assembly	H-436 to VTA	Disconnect from volume tank port. Disconnect strain relief. Install port cap, and tighten 3/8 to 1/2 turn after O-ring engages. Install hose plug.	VTA		
<b>PART IV - DISCONNECTING LP AIR SUPPLY HOSE</b>						
1	LP Air Hose Assembly	H-101	Disconnect from volume tank <b>LP AIR OUT</b> bulkhead connector. Disconnect safety cable. Install hose plug.	VTA		
2	LP Air Hose Assembly	H-101	Disconnect from control console <b>PRIMARY SUPPLY</b> bulkhead connector. Disconnect safety cable. Install hose plug.	CCA		
<b>PART V - PREPARING SYSTEM FOR STOWAGE</b>						
1	CCA	N/A	Remove from platform. Install and secure cover.	CCA		
2	VTA	N/A	Break down tables. Install and secure covers.	VTA		
<b>NOTE 4:</b> Nonionic Detergent (NID) solution is prepared by mixing 1 teaspoon of nonionic detergent with 1 gallon of warm, fresh water.						
3	System	N/A	Wash system exterior with NID solution and warm, fresh water. Dry.	System		
4	System	N/A	Inspect for damage. Tighten nuts and bolts. Conduct PMS as required.	System		
5	HP Air Hose Assemblies	H-436 (2)	Hang on ASRA doors.	ASRA		
6	ASRA Doors	N/A	Close and secure.	ASRA		
7	ASRA Storage Cover	N/A	Place on ASRA.	ASRA		
8	System	N/A	Stow equipment.	System		





THIS PAGE INTENTIONALLY LEFT BLANK

## **APPENDIX C**

# **INTERNAL INSPECTION PROCEDURES FOR KEVLAR® AND CARBON FIBER HP AIR FLASKS**

THIS PAGE INTENTIONALLY LEFT BLANK

SS500-HK-MMO-010

## APPENDIX C

### INTERNAL INSPECTION PROCEDURES FOR KEVLAR® AND CARBON FIBER HP AIR FLASKS

#### C.1 INTRODUCTION

This appendix provides procedures for internal inspection of the high pressure (HP) air flasks used in the Lightweight Dive System (LWDS) MK 3 Mod 0 and Mod 1. External inspection procedures are provided in Appendices D and E.

#### C.2 INTERNAL INSPECTION OF PRIMARY AND SECONDARY HP AIR FLASKS

The following internal inspection procedures, which apply to both Kevlar® and carbon fiber-reinforced flasks, are recommended by the Compressed Gas Association's publication, CGA C-6.2, *Guidelines for Visual Inspection & Requalification of Fiber Reinforced High Pressure Cylinders*, dated 1988. Another source for internal inspection of the HP air flasks is Maintenance Requirement Card (MRC) 36M-1 (MIP No. 5921/171) in the LWDS Planned Maintenance System (PMS).

- a. **Threads:** Inspect threads for nicks, cuts, cracks, corrosion, and damage.
- b. **O-ring Gland:** Ensure O-ring gland is clean and free from damage.
- c. **Flask Interior:** Using a borescope, inspect flask interior for evidence of the following:
  - (1) **Moisture:** If moisture appears in flask, a review of the filter charging system is required to prevent further flask damage.
  - (2) **Pitting:** Any pitting in a new flask is unacceptable and requires the flask to be returned to depot. Random, minor, and shallow pitting is acceptable in used flasks; however, groups of shallow pits, lines of shallow pits, or deep pits (with shadows cast in bottom of pits) are unacceptable and require the flask to be returned to depot.
  - (3) **Dents:** Dents visible on interior surfaces are cause for condemnation and disposal of flask (see paragraph C.3).
  - (4) **Cracks:** Cracks visible on interior surfaces are cause for condemnation and disposal of flask (see paragraph C.3).
  - (5) **Foreign Material:** If any foreign material is found in the flask, it must be identified and its source located. The flask must be returned to a repair activity for cleaning before further use of the flask.



SS500-HK-MMO-010

### **C.3 CONDEMNATION AND DISPOSAL OF FLASKS**

If a flask contains dents or cracks that render it unfit for continued service, discovery of such damage shall be recorded in writing by the diver, including notation of the flask serial number. The flask must be depressurized and condemned by drilling a hole through the inspector's mark on the manufacturer's label. The flask is then disposed of in accordance with applicable ship/facility procedures.

**APPENDIX D**

**EXTERNAL INSPECTION PROCEDURES  
FOR KEVLAR® HP AIR FLASKS**

THIS PAGE INTENTIONALLY LEFT BLANK

SS500-HK-MMO-010

## APPENDIX D

### EXTERNAL INSPECTION PROCEDURES FOR KEVLAR® HP AIR FLASKS

#### D.1 INTRODUCTION

This appendix provides procedures for external inspection of the Kevlar® high pressure (HP) air flasks used in the Lightweight Dive System (LWDS) MK 3 Mod 0 and Mod 1. External inspection of the carbon fiber flasks is provided in Appendix E and internal inspection of both types of flasks is presented in Appendix C.

#### D.2 EXTERNAL INSPECTION OF PRIMARY AND SECONDARY HP AIR FLASKS

The exterior surface of a fiber-reinforced flask does not look or feel the same as an all-metal flask; therefore, personnel should be aware of differences in appearance and acceptance criteria. The HP air flasks shall be inspected to ensure they are in good condition and suitable for use in accordance with U.S. Navy specifications. Ensure flasks are clean and free from any dirt, labels, or attachments that may interfere with visual inspection; however, do not remove any paint nor the flask manufacturer's label (paragraph D.2.5).

**D.2.1 Types of External Damage.** The following types of external damage may occur to fiber-reinforced flasks:

- a. **Scuffs (Figure D-1):** Minor abrasions (Level 1 Damage) to protective flask coating (i.e., paint).
- b. **Abrasions (Figure D-2):** Greater loss of surface with numerous fibers visible. Can be caused by sliding contact with a rough surface. Flat spots evident on surface could indicate excessive loss of composite thickness.
- c. **Cuts (Figure D-3):** Damage caused by sharp object.
- d. **Impact Damage:** Impact damage in the form of dents, bruises, or delamination can be caused by dropping or by a blow from a blunt object.
  - (1) **Dents or Bruises (Figure D-4):** Damage may appear as crazing (hairline cracking) or frosting of the resin.
  - (2) **Delamination (Figure D-5):** Delamination is a separation between the plies of the overwrap or at the overwrap-liner interface. Damage may appear as a whitish patch, or like a blister or air space beneath the surface.



Figure D-1. Flask Scuffs\*

\*Photo reprinted with permission from the Compressed Gas Association, Inc., publication no. CGA C-6.2, 1988, *Guidelines for Visual Inspection & Requalification of Fiber Reinforced High Pressure Cylinders*.

THIS PAGE INTENTIONALLY LEFT BLANK

SS500-HK-MMO-010

ABRASION DAMAGE



Figure D-2. Flask Abrasions\*

\*Photos reprinted with permission from the Compressed Gas Association, Inc., publication no. CGA C-6.2, 1988, *Guidelines for Visual Inspection & Requalification of Fiber Reinforced High Pressure Cylinders*.

THIS PAGE INTENTIONALLY LEFT BLANK

SS500-HK-MMO-010

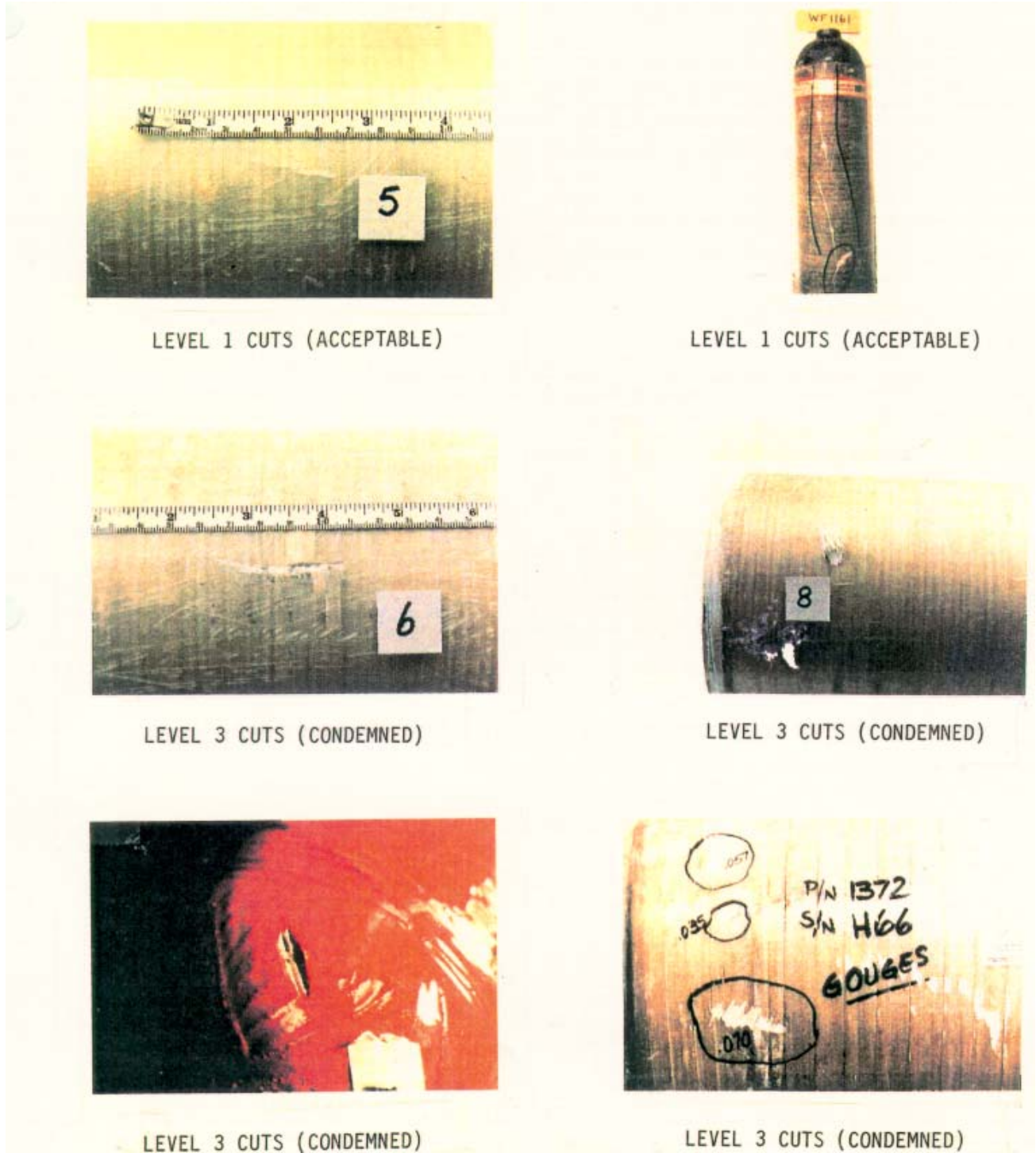


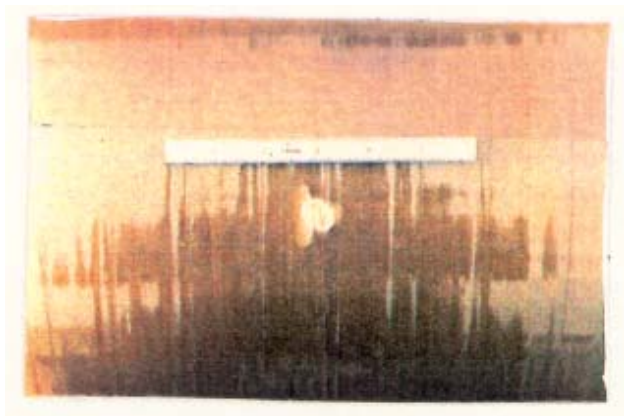
Figure D-3. Flask Cuts\*

\*Photos reprinted with permission from the Compressed Gas Association, Inc., publication no. CGA C-6.2, 1988, *Guidelines for Visual Inspection & Requalification of Fiber Reinforced High Pressure Cylinders*.



THIS PAGE INTENTIONALLY LEFT BLANK

SS500-HK-MMO-010

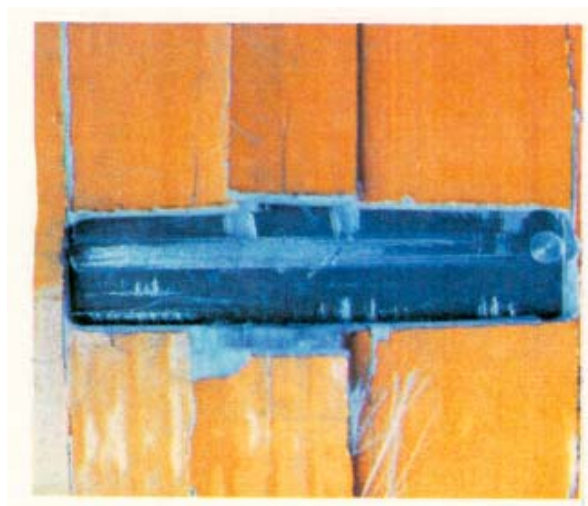


LEVEL 1 IMPACT DAMAGE (ACCEPTABLE)



LEVEL 3 IMPACT DAMAGE  
(CONDEMNED)

**Figure D-4. Flask Dents\***



**Figure D-5. Flask Delamination\***

\*Photos reprinted with permission from the Compressed Gas Association, Inc., publication no. CGA C-6.2, 1988, *Guidelines for Visual Inspection & Requalification of Fiber Reinforced High Pressure Cylinders*.

THIS PAGE INTENTIONALLY LEFT BLANK

## SS500-HK-MMO-010

- e. **Structural Damage (Figure D-6):** Indicates severe damage to the flask. This damage is extreme and may involve damage to the liner as well as the outer composite.
- f. **Fire Damage (Figure D-7):** Flasks with signs of fire damage will be condemned.

**D.2.2 Levels of External Damage.** The following are the levels of external damage that may occur to fiber-reinforced flasks:

- a. **Level 1 Damage (Acceptable):** Level 1 damage is minor and is considered normal and as having no adverse effects on the safety of the flask and its continued use. Scratched paint, nicks, or dings that have no appreciable depth, or no significant quantity of frayed fibers, are considered in this category. The repair procedure for flasks with Level 1 damage is presented in paragraph 6.8.3.1.
- b. **Level 2 Damage (Rejectable, additional inspection or repairs required):** Level 2 damage may be cuts or gouges that are deeper or longer than those of Level 1, or may include a group of severed fibers. This level of damage may be repairable. If an evaluation is made that the flask has Level 2 damage, it should be returned to an authorized repair facility or depot for further evaluation and repair.
- c. **Level 3 Damage (Condemned, not repairable):** Level 3 damage is a flask that has been rendered unfit for continued service and cannot be repaired. Discovery of such damage shall be recorded in writing by the diver, including notation of the flask serial number. The flask must be depressurized and condemned by drilling a hole through the inspector's mark on the manufacturer's label. The flask is then disposed of in accordance with applicable ship/facility procedures.

**D.2.3 External Inspection Criteria.** The following external inspection criteria apply to fiber-reinforced flasks and are summarized in Table D-1.

- a. **Abrasions:**
  - (1) **Level 1 Damage:** Minor abrasions, such as scuffs, are acceptable if they do not exceed a depth of 0.010 inch. Repair in accordance with paragraph 6.8.3.1.
  - (2) **Level 2 Damage:** Abrasions with depths greater than 0.010 inch but less than 0.020 inch and with a maximum length of 1 inch transverse to the fiber are rejectable. Flasks must be sent to an authorized repair facility or depot for further evaluation, possible repair, and hydrostatic testing (if repaired).
  - (3) **Level 3 Damage:** Flasks with abrasions deeper than 0.040 inch must be condemned and disposed of in accordance with paragraph D.2.2.c.
- b. **Cuts:**
  - (1) **Level 1 Damage:** Cuts or scratches less than 0.010 inch deep are acceptable. Repair in accordance with paragraph 6.8.3.1.

## SS500-HK-MMO-010

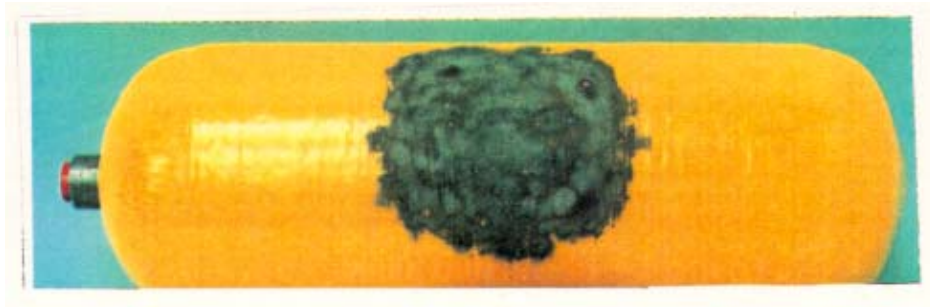
- (2) **Level 2 Damage:** Cuts or gouges with depths greater than 0.010 inch but less than 0.040 inch and with a maximum length of 1 inch transverse to the fiber are rejectable. Flasks must be sent to an authorized repair facility or depot for further evaluation, possible repair, and hydrostatic testing (if repaired).
  - (3) **Level 3 Damage:** Flasks with cuts deeper than 0.040 inch or with bare metal showing through a cut in the Kevlar® wrapping must be condemned and disposed of in accordance with paragraph D.2.2.c.
- c. **Dents:**
- (1) **Level 1 Damage:** Dents existing in localized areas of the fiberglass wrapping only are acceptable. If damage includes exposed fiber ends and is less than 0.010 inch in depth, the area must be repaired with an epoxy coating in accordance with paragraph 6.8.3.1.
  - (2) **Level 2 Damage:** If the depth of exposed fiber ends is greater than 0.010 inch but less than 0.020 inch, the flask must be sent to an authorized repair facility or depot for further evaluation, possible repair, and hydrostatic testing (if repaired).
  - (3) **Level 3 Damage:** If the dent affects structural configuration, the flask must be condemned and disposed of in accordance with paragraph D.2.2.c.
- d. **Delamination:** Delaminations are acceptable only if repaired by coating all exposed fibers with epoxy. Flasks with signs of delamination must be sent to an authorized repair facility or depot for further evaluation, possible repair, and hydrostatic testing if repaired. If the delaminated area shows evidence of broken fibers or flaw growth after hydrostatic testing, the flask must be condemned.
- e. **Structural Damage—Level 3 Damage:** Structural damage is severe damage, usually with visible evidence of a change in envelope configuration. A flask must be condemned if bulges, a cocked end fitting, or concave areas are evident on the domes or on the flask section. If visual inspection of the flask interior (Appendix C) shows evidence of exterior damage causing deformation of the liner, the flask must be condemned. All flasks with structural damage must be condemned and disposed of in accordance with paragraph D.2.2.c.
- f. **Fire Damage—Level 3 Damage:** Flasks with signs of fire damage must be condemned and disposed of in accordance with paragraph D.2.2.c. Fire damage may be evidenced by charring or burning of the composite, paint, labels, or plastic components of the valve. If, however, the protective coating is only soiled from smoke or other debris and is found by examination to be intact underneath, the flask shall not be considered affected.

SS500-HK-MMO-010

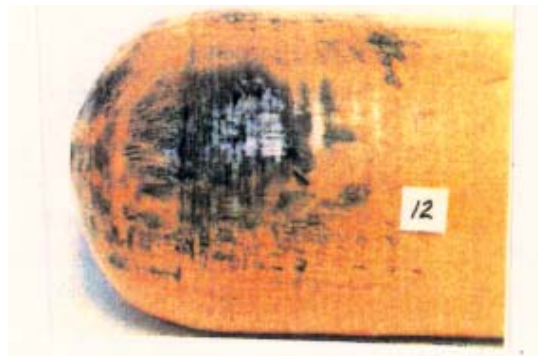


LEVEL 3 STRUCTURAL DAMAGE (CONDEMNED)

**Figure D-6. Flask Structural Damage\***



LEVEL 3 FIRE DAMAGE (CONDEMNED)



LEVEL 3 FIRE DAMAGE (CONDEMNED)

**Figure D-7. Flask Fire Damage\***

\*Photos reprinted with permission from the Compressed Gas Association, Inc., publication no. CGA C-6.2, 1988, *Guidelines for Visual Inspection & Requalification of Fiber Reinforced High Pressure Cylinders*.

THIS PAGE INTENTIONALLY LEFT BLANK

## SS500-HK-MMO-010

**Table D-1. Summary of External Inspection Criteria for Fully-Wound Composite Flasks****NOTE**

All measurements shall be made transverse to cut direction. Use a Starrett dial depth gauge No. 643JZ.

<b>PART A - LEVEL 1 DAMAGE</b>		
<b>Damage Level</b>	<b>Inspection Criteria and Type of Damage</b>	<b>Maintenance Action</b>
Acceptable	1. Abrasions in this category must not exceed a depth of 0.010 inch; if they do, refer to Part B - Level 2 Damage.	1. Depth less than 0.010 inch, repair per paragraph 6.8.3.1.
	2. Cuts in this category must not exceed a depth of 0.010 inch; if they do, refer to Part B - Level 2 Damage.	2. Depth less than 0.010 inch, repair per paragraph 6.8.3.1.
	3. Loose or broken fibers must not exceed a depth of 0.010 inch; if they do, refer to Part B - Level 2 Damage.	3. Depth less than 0.010 inch, repair per paragraph 6.8.3.1.
	4. Bare metal must not be visible through the Kevlar® wrapping; if it is, refer to Part C - Level 3 Damage.	4. Do not repair; see Part C - Level 3 Damage.
	5. Manufacturer's label must be in place; if it is not, refer to Part C - Level 3 Damage.	5. Do not replace label; see Part C - Level 3 Damage.
	6. All information on manufacturer's label must be legible; if it is not, refer to paragraph D.2.5.	6. Prepare new label; see paragraph D.2.5.
	7. Hydrostatic test date must not have expired; if it has, refer to Part B - Level 2 Damage.	7. Do not use flask; see Part B - Level 2 Damage.
<b>PART B - LEVEL 2 DAMAGE</b>		
<b>Damage Level</b>	<b>Inspection Criteria and Type of Damage</b>	<b>Maintenance Action</b>
Rejectable - additional inspection or repairs required	1. Abrasions in this category must not exceed a depth of 0.020 inch and a maximum of 1 inch in length transverse to the fibers; if they do, refer to Part C - Level 3 Damage.	1. Send to authorized repair facility or depot for further evaluation, repair, and hydrostatic testing.
	2. Cuts in this category must not exceed a depth of 0.040 inch and a maximum of 1 inch in length transverse to the fibers; if they do, refer to Part C - Level 3 Damage.	2. Send to authorized repair facility or depot for further evaluation, repair, and hydrostatic testing.
	3. Loose or broken fibers must not exceed a depth of 0.020 inch and a maximum of 1 inch in length transverse to the fibers; if they do, refer to Part C - Level 3 Damage.	3. Send to authorized repair facility or depot for further evaluation, repair, and hydrostatic testing.
	4. Bare metal must not be visible through the Kevlar® wrapping; if it is, refer to Part C - Level 3 Damage.	4. Do not repair; see Part C - Level 3 Damage.



## SS500-HK-MMO-010

**Table D-1. Summary of External Inspection Criteria for Fully-Wound Composite Flasks—Continued**

<b>PART B - LEVEL 2 DAMAGE—Continued</b>		
<b>Damage Level</b>	<b>Inspection Criteria and Type of Damage</b>	<b>Maintenance Action</b>
Rejectable - additional inspection or repairs required	5. Manufacturer's label must be in place; if it is not, refer to Part C - Level 3 Damage.	5. Do not replace label; see Part C - Level 3 Damage.
	6. All information on manufacturer's label must be legible; if it is not, refer to paragraph D.2.5.	6. Prepare new label; see paragraph D.2.5.
	7. Expired hydrostatic test date.	7. Send to authorized repair facility or depot for hydrostatic testing.
<b>PART C - LEVEL 3 DAMAGE</b>		
<b>Damage Level</b>	<b>Inspection Criteria and Type of Damage</b>	<b>Maintenance Action</b>
Condemned - not repairable	1. Abrasions exceeding a depth of 0.040 inch or length of 1 inch transverse to fibers.	Not repairable. Depressurize flask and drill hole in flask through manufacturer's label. Dispose of flask in accordance with applicable ship/facility procedures.
	2. Cuts exceeding a depth of 0.040 inch or length of 1 inch transverse to fibers.	
	3. Loose or broken fibers exceeding a depth of 0.040 inch or length of 1 inch transverse to fibers.	
	4. Bare metal visible through Kevlar® wrapping.	
	5. Manufacturer's label missing.	
	6. Severe structural damage affecting flask configuration.	
	7. Signs of fire damage (evidence of charring or burning of composite, labels, paint, or plastic components of valve).	

**D.2.4 Hydrostatic Testing.** Flasks shall be hydrostatically tested every three years or whenever any Level 2 repair has been made. The test facility must be authorized by the Department of Transportation (DOT) as a Class B retester capable of hydrostatic testing using the water jacket volumetric expansion method as defined in Compressed Gas Association (CGA) pamphlet C-1, *Methods of Hydrostatic Testing of Compressed Gas Cylinders*, **with the following exception:**

- a. Zero burette and observe water level for thirty seconds to ensure there are no temperature variations. Apply pressure of 4,250 pounds per square inch (psi) to flask at a rate not to exceed 3,000 psi per minute. Lock off and check for leaks. If water level is constant, release pressure and zero burette.

## SS500-HK-MMO-010

- b. Pressurize flask to 5,000 psi at a rate not to exceed 3,000 psi per minute and maintain pressure for 60 seconds or more (the time it takes for the composite to settle) to ensure complete expansion of flask.

**NOTE**

The flask must be condemned if the permanent expansion exceeds 5 percent of the total expansion.

- c. Depressurize flask, wait for 60 seconds or more to allow flask time to stabilize, then record the permanent expansion.
- d. Reclean flask as required. Hydrostatically testing with Grade B water may eliminate the need for recleaning provided no contamination is suspected.

A list of authorized retesters is available on-line at [http://hazmat.dot.gov/files/approvals/hydro/hydro\\_retesters.htm](http://hazmat.dot.gov/files/approvals/hydro/hydro_retesters.htm). Technicians may search for testers by identification number or by state listing. Each section provides tester identification number, tester name, facility address, tester class, and effective date.

**D.2.5 Manufacturer's Label.** The manufacturer's label is located on the sidewall near the end of the flask containing the valve outlet. If the manufacturer's label is missing, the flask must be condemned and disposed of in accordance with paragraph D.2.2.c. If the label is illegible, the manufacturer shall be asked for the information. The missing data shall be placed on a label, and the label shall be securely affixed to the flask and overcoated with epoxy. The manufacturer's label contains the following information:

- Department of Transportation (DOT) exemption number followed by service pressure (The most current DOT exemption letters are available on-line as shown in Appendix F. A printed copy of the applicable exemption letter is required when using commercial transportation.)
- Numerical serial number followed by inspector's mark
- Manufacturer's identification
- Date of manufacture

THIS PAGE INTENTIONALLY LEFT BLANK

**APPENDIX E**

**EXTERNAL INSPECTION PROCEDURES  
FOR CARBON FIBER  
HP AIR FLASKS**

THIS PAGE INTENTIONALLY LEFT BLANK

SS500-HK-MMO-010

## **APPENDIX E**

### **EXTERNAL INSPECTION PROCEDURES FOR CARBON FIBER HP AIR FLASKS**

#### **E.1 INTRODUCTION**

This appendix provides procedures for external inspection of the carbon fiber high pressure (HP) air flasks used in the Lightweight Dive System (LWDS) MK 3 Mod 0 and Mod 1. External inspection of the Kevlar® flasks is provided in Appendix D and internal inspection of both types of flasks is presented in Appendix C.

#### **E.2 EXTERNAL INSPECTION OF PRIMARY AND SECONDARY HP AIR FLASKS**

Until the Compressed Gas Association pamphlet is available, use the current exemption from Luxfer Gas Cylinders or Structural Composites Industries (SCI) for inspection criteria for the carbon fiber flasks. The exemptions, DOT-E 10915 and DOT-E 10945 respectively, are contained in Appendix F in this manual.

THIS PAGE INTENTIONALLY LEFT BLANK

## **APPENDIX F**

# **U.S. DEPARTMENT OF TRANSPORTATION (DOT) COMPOSITE FLASK EXEMPTIONS AND ASSOCIATED DOCUMENTS**



THIS PAGE INTENTIONALLY LEFT BLANK

SS500-HK-MMO-010

## APPENDIX F

### U.S. DEPARTMENT OF TRANSPORTATION (DOT) COMPOSITE FLASK EXEMPTIONS AND ASSOCIATED DOCUMENTS

#### F.1 INTRODUCTION

According to U.S. Department of Transportation (DOT) regulations, a current copy of all applicable exemptions must accompany the commercial transportation of composite flasks. To help meet this requirement, on-line addresses have been provided in this appendix to allow access to the most current exemptions and the associated documents that apply to the flasks used in the Lightweight Dive System (LWDS) MK 3 Mod 0 and Mod 1.

Although copies of the applicable DOT composite flask exemptions that were in force when this manual was issued have been included in this appendix, please note that they will no longer be supplied with updates to this manual. ***As a result, manual holders must assume the responsibility for ensuring the most current copy of each exemption is always available by accessing the on-line addresses provided in this appendix on a timely basis (i.e., weekly, monthly, or immediately before transportation of the flasks).*** The expiration date should not be relied upon as the basis for checking for new revisions as the exemption may be revised long before the indicated expiration date. This appendix may be used to store printed copies of each exemption, and the originals may be used to make the required number of copies.

The flask exemptions listed below apply to the two types of flasks that are approved for use in the LWDS MK 3 Mod 0 and Mod 1. To determine which DOT exemption applies to the flask to be transported, check the flask label for the exemption number. To verify that your printed copy of the exemption is current, access the on-line address for that exemption and compare the stamped date (usually in upper right-hand corner), revision number (e.g., FIFTH REVISION), and expiration date on the printed copy with that on the on-screen copy. If the numbers match, your printed copy is current and you can simply make the appropriate number of copies. If the numbers are different, print out the new revision, make the required number of copies, and replace the old revision with the new one. If additional guidance is needed for packaging, marking, etc., read the instructions given in the exemption. The associated documents referenced in the exemptions (DOT-CFFC and DOT FRP-1 Standard) are listed on the reverse side of this page.

#### F.2 COMPOSITE FLASK EXEMPTIONS

**DOT-E 10915:** Luxfer Gas Cylinders exemption for non-DOT specification fully wrapped carbon-fiber reinforced aluminum lined cylinders (conforming to DOT-CFFC)

<http://hazmat.dot.gov/exemptions/E10915.pdf>

## SS500-HK-MMO-010

**DOT-E 10945:** Structural Composite Industries (SCI) exemption for non-DOT specification fully wrapped carbon-fiber reinforced aluminum lined cylinders (conforming to DOT-CFFC)

<http://hazmat.dot.gov/exemptions/E10945.pdf>

**DOT-E 10970:** Luxfer Gas Cylinders exemption for non-DOT specification fiber reinforced plastic full composite cylinders (conforming to DOT FRP-1 Standard)

<http://hazmat.dot.gov/exemptions/E10970.pdf>

**DOT-E 8162:** Structural Composite Industries (SCI) exemption for non-DOT specification fiber reinforced plastic full composite cylinders (conforming to DOT FRP-1 Standard)

<http://hazmat.dot.gov/exemptions/E08162.pdf>

### **F.3 ASSOCIATED DOCUMENTS**

**DOT-CFFC:** *Appendix A, Basic Requirements for Fully Wrapped Carbon-Fiber Reinforced Aluminum Lined Cylinders (DOT-CFFC)*. Note that on-line address must include cfc followed by an underscore.

[http://hazmat.dot.gov/cfc\\_std.pdf](http://hazmat.dot.gov/cfc_std.pdf)

**DOT FRP-1 STANDARD:** *Basic Requirements for Fiber Reinforced Plastic (FRP) Type 3FC Composite Cylinders*

<http://hazmat.dot.gov/frp-1.pdf>

### **NOTE**

Although the CFFC and FRP-1 are not revised as frequently as the exemptions, it is recommended that the websites be checked at regular intervals in order to maintain the most current copy.



U.S. Department  
of Transportation  
**Research and  
Special Programs  
Administration**

400 Seventh St., S.W.  
Washington, D.C. 20590

SEP 9 2002

DOT-E 10915  
(THIRTEENTH REVISION)

EXPIRATION DATE: April 30, 2004

(FOR RENEWAL, SEE 49 CFR § 107.109)

1. GRANTEE: Luxfer Gas Cylinders  
Riverside, California  
(Former Grantee: Luxfer USA Limited)
2. PURPOSE AND LIMITATIONS:
  - a. This exemption authorizes the manufacture, mark, sale and use of a non-DOT specification fully wrapped carbon-fiber reinforced aluminum lined cylinder for the transportation in commerce of the materials authorized by this exemption. This exemption provides no relief from any Hazardous Materials Regulation (HMR) other than as specifically stated herein.
  - b. The safety analyses performed in development of this exemption only considered the hazards and risks associated with transportation in commerce.
3. REGULATORY SYSTEM AFFECTED: 49 CFR Parts 106, 107 and 171-180.
4. REGULATIONS FROM WHICH EXEMPTED: 49 CFR §§ 173.34(e), 173.302(a), 173.304(a) and 175.3 in that a non-DOT specification cylinder is not authorized except as specified herein.
5. BASIS: This exemption is based on the application of Luxfer Gas Cylinders dated May 16, 2002, submitted in accordance with § 107.109.

6. HAZARDOUS MATERIALS (49 CFR § 172.101):

Proper Shipping Name/ Hazardous Material Description	Hazard Class/ Division	Identi- fication Number	Packing Group
Air, compressed (containing up to 39% by volume oxygen content)	2.2	UN1002	N/A
Argon, compressed	2.2	UN1006	N/A
Carbon Dioxide	2.2	UN1013	N/A
Compressed gas, n.o.s.	2.2	UN1956	N/A
Compressed gas, oxidizing, n.o.s.	2.2	UN3156	N/A
Helium, compressed	2.2	UN1046	N/A
Hydrogen, compressed	2.1	UN1049	N/A
Liquefied gas, n.o.s.	2.2	UN3163	N/A
Methane, compressed or Natural gas, compressed (with high methane content)	2.1	UN1971	N/A
Nitrogen, compressed	2.2	UN1066	N/A
Nitrous Oxide	2.2	UN1070	N/A
Oxygen, compressed	2.2	UN1072	N/A

7. SAFETY CONTROL MEASURES:

a. PACKAGING - Packaging prescribed is a fully wrapped carbon-fiber reinforced aluminum lined cylinder manufactured and marked in conformance with Basic Requirements for Fully Wrapped Carbon-Fiber Reinforced Aluminum Lined Cylinders (DOT-CFFC) (Fourth Revision), dated November 2000.

b. TESTING: Cylinders retested prior to May 11, 2001 must be retested within 36 months of the retest date marked on the cylinder. Cylinders retested on or after May 11, 2001 must be reinspected and hydrostatically retested at least once every five years. Testing must be performed in accordance with § 173.34(e), tested to 5/3 of the marked service pressure, and the latest edition of CGA pamphlet C-6.2 "Guidelines for Visual Inspection and Re-qualification of Fiber Reinforced High Pressure Cylinders", except as specifically noted herein:

(1) Cylinders must be volumetrically tested by the water jacket method suitable for the determination of the cylinder expansion for a minimum test time of one minute.

(2) A maximum permanent expansion to total expansion ratio does not apply. The cylinder must be condemned if the elastic expansion exceeds the rejection elastic expansion (REE) as marked on the cylinder.

(3) Retest markings must be applied on a label securely affixed to the cylinder and overcoated with epoxy, near the original test date. Metal stamping of the composite surface is prohibited. Reheat treatment of rejected cylinders is not authorized.

(4) Cylinders with fiber damage (cuts, abrasions, etc.) that exceed Level 1 type damage as defined in CGA Pamphlet C-6.2 and meet the following depth and length criteria are considered to have Level 2 damage:

(i) Depth - Damage that upon visual inspection is seen to penetrate the outer fiberglass layer but does not expose the carbon layer beneath, or that has a measured depth of greater than 0.005 and less than 0.045 inch for cylinders with an outside diameter greater than 7.5 inches or less than 0.035 inches for cylinders 7.5 inches or less in outside diameter;

(ii) Length - Damage that has a maximum allowable length of:

Region	Direction of fiber damage	Maximum length of damage
Cylinder sidewall and domes	Transverse to fiber direction (longitudinal direction)	20% of the length of the straight sidewall section of the cylinder
Cylinder sidewall and domes	In the direction of the fiber (circumferential direction)	20% of the length of the straight sidewall section of the cylinder

(5) Cylinders with damage that meet the Level 2 criteria must be rejected. Retesters must contact the cylinder manufacturer in the event that damage is questionable based on this criteria. Repair of rejected cylinders is authorized for Level 2 type damage. Repairs must be made in accordance with CGA pamphlet C-6.2, prior to the hydrostatic pressure test. Repairs must be evaluated after the hydrostatic test.

(6) Cylinders that have direct fiber damage that penetrates through the outer fiberglass layer and into the carbon layer, or that have a measured damage depth of greater than the Level 2 maximum stated in (5)(a) above are considered to have Level 3 type damage. Cylinders that have damage with depth meeting Level 2, but length exceeding the Level 2 maximum are considered to have Level 3 type damage. Cylinders with Level 3 type damage are not authorized to be repaired, and must be condemned.

(7) A hydrostatic retest may be repeated as provided for in § 173.34(e)(4), only two such retests are permitted. Pressurization prior to the official hydrostatic test for the purpose of a systems check must not exceed 85% of the required test pressure.

c. OPERATIONAL CONTROLS -

(1) Cylinders manufactured under this exemption are not authorized for use fifteen (15) years after the date of manufacture.

(2) Cylinders may not be used for underwater breathing purposes.

(3) Cylinders used in oxygen service must conform with § 173.302(a)(5)(i)-(iv). Cylinders used in nitrous oxide service must conform with § 173.304(a)(4).

(4) A cylinder that has been subjected to fire may not be returned to service.

(5) Transportation of flammable gases is not authorized aboard passenger-carrying aircraft or cargo vessel.

(6) Transportation of oxygen is only authorized when in accordance with § 172.102(c)(2) Special Provision A52 and §§ 175.85(h) and (i).

(7) Cylinders must be packaged in accordance with § 173.301(k).

SEP 9 2002

8. SPECIAL PROVISIONS:

a. In accordance with the provisions of Paragraph (b) of § 173.22a, persons may use the packaging authorized by this exemption for the transportation of the hazardous materials specified in paragraph 6, only in conformance with the terms of this exemption.

b. A person who is not a holder of this exemption, but receives a package covered by this exemption, may reoffer it for transportation provided no modifications or changes are made to the package and it is offered for transportation in conformance with this exemption and the HMR.

c. A current copy of this exemption must be maintained at each facility where the package is offered or reoffered for transportation.

d. A current copy of this exemption must be maintained at each facility where the package is manufactured under this exemption. It must be made available to a DOT representative upon request.

e. Each packaging manufactured under the authority of this exemption must be either (1) marked with the name of the manufacturer and location (city and state) of the facility at which it is manufactured or (2) marked with a registration symbol designated for a specific manufacturing facility.

f. The cylinders described in this exemption are authorized only for normal transportation as an article of commerce i.e., the movement of hazardous materials packages from consignor to consignee.

9. MODES OF TRANSPORTATION AUTHORIZED: Motor vehicle, rail freight, cargo vessel, cargo-only aircraft, and passenger-carrying aircraft (see paragraphs 7.c.(5) and 7.c.(6) for restrictions).10. MODAL REQUIREMENTS:

a. A current copy of this exemption must be carried aboard each cargo vessel or aircraft used to transport packages covered by this exemption.

b. The shipper must furnish a current copy of this exemption to the air carrier before or at the time the shipment is tendered.




11. COMPLIANCE: Failure by a person to comply with any of the following may result in suspension or revocation of this exemption and penalties prescribed by the Federal hazardous materials transportation law, 49 U.S.C. 5101 et seq:
- o All terms and conditions prescribed in this exemption and the Hazardous Materials Regulations, Parts 171-180.
  - o Registration required by § 107.601 et seq., when applicable.

Each "Hazmat employee", as defined in § 171.8, who performs a function subject to this exemption must receive training on the requirements and conditions of this exemption in addition to the training required by §§ 172.700 through 172.704.

No person may use or apply this exemption, including display of its number, when the exemption has expired or is otherwise no longer in effect.

12. REPORTING REQUIREMENTS: The carrier is required to report any incident involving loss of packaging contents or packaging failure to the Associate Administrator for Hazardous Materials Safety (AAHMS) as soon as practicable. (Sections 171.15 and 171.16 apply to any activity undertaken under the authority of this exemption.) In addition, the holder(s) of this exemption must also inform the AAHMS, in writing, as soon as practicable of any incidents involving the package and shipments made under this exemption.

Issued in Washington, D.C.



*for* Robert A. McGuire  
Associate Administrator for  
Hazardous Materials Safety

SEP 9 2002

(DATE)

Address all inquiries to: Associate Administrator for Hazardous Materials Safety, Research and Special Programs Administration, Department of Transportation, Washington, D.C. 20590.  
Attention: DHM-31.

Copies of this exemption may be obtained by accessing the Hazardous Materials Safety Homepage at <http://hazmat.dot.gov/exemptions> Photo reproductions and legible reductions of this exemption are permitted. Any alteration of this exemption is prohibited.

PO: SS/AM



U.S. Department  
of Transportation  
**Research and  
Special Programs  
Administration**

400 Seventh St., S.W.  
Washington, D.C. 20590

SEP 9 2002

DOT-E 10945  
(THIRTEENTH REVISION)

EXPIRATION DATE: June 30, 2004

(FOR RENEWAL, SEE 49 CFR § 107.109)

1. GRANTEE: Structural Composites Industries  
Pomona, California
2. PURPOSE AND LIMITATIONS:
  - a. This exemption authorizes the manufacture, mark, sale, and use of non-DOT specification fully wrapped carbon-fiber reinforced aluminum lined cylinders for the transportation in commerce of the materials authorized by this exemption. This exemption provides no relief from the Hazardous Materials Regulations (HMR) other than as specifically stated herein.
  - b. The safety analyses performed in development of this exemption only considered the hazards and risks associated with transportation in commerce.
3. REGULATORY SYSTEM AFFECTED: 49 CFR Parts 106, 107 and 171-180.
4. REGULATIONS FROM WHICH EXEMPTED: 49 CFR §§ 173.34(e), 173.302(a)(1), 173.304(a)(1) and 175.3 in that non-DOT specification cylinders are not authorized except as prescribed herein.
5. BASIS: This exemption is based on the application of Structural Composites Industries dated April 25, 2002, submitted in accordance with § 107.109.

6. HAZARDOUS MATERIALS (49 CFR § 172.101):

Proper Shipping Name/ Hazardous Materials Description	Hazard Class/ Division	Identi- fication Number	Packing Group
Air, compressed (containing up to 39% by volume oxygen content)	2.2	UN1002	N/A
Argon, compressed	2.2	UN1006	N/A
Bromotrifluoromethane or Refrigerant Gas, R 13B1	2.2	UN1009	N/A
Carbon Dioxide, compressed	2.2	UN1013	N/A
Chlorodifluorobromethane or Refrigerant Gas, R 22	2.2	UN1974	N/A
Compressed gas, n.o.s.	2.2	UN1956	N/A
Helium, compressed	2.2	UN1046	N/A
Heptafluoropropane or Refrigerant Gas R 227	2.2	UN3296	N/A
Hydrogen, compressed	2.1	UN1049	N/A
Methane, compressed or Natural gas, compressed	2.1	UN1971	N/A
Nitrogen, compressed	2.2	UN1066	N/A
Nitrous Oxide, compressed	2.2	UN1070	N/A
Oxygen, compressed	2.2	UN1072	N/A

7. SAFETY CONTROL MEASURES:

a. PACKAGING - Prescribed packaging is a fully wrapped carbon-fiber reinforced aluminum lined cylinder made in conformance with the Basic Requirements for Fully Wrapped Carbon-Fiber Reinforced Aluminum Lined Cylinders (DOT-CFFC Fourth Revision), dated November 2000.

b. TESTING - Cylinders retested prior to July 1, 2001 must be retested within 36 months of the retest date marked on the cylinder. Cylinders retested after July 1, 2001 must be

reinspected and hydrostatically retested at least once every five years. Testing must be performed in accordance with § 173.34(e), tested to 5/3 of the marked service pressure and the latest edition of CGA pamphlet C-6.2 "Guidelines for Visual Inspection and Re-qualification of Fiber Reinforced High Pressure Cylinders", except as specifically noted herein:

(1) Cylinders must be volumetrically tested by the water jacket method suitable for the determination of the cylinder expansion for a minimum test time of one minute.

(2) A maximum permanent expansion to total expansion ratio does not apply. The cylinder must be condemned if the elastic expansion exceeds the rejection elastic expansion (REE) as marked on the cylinder.

(3) Retest markings must be applied on a label securely affixed to the cylinder and overcoated with epoxy, near the original test date. Metal stamping of the composite surface is prohibited. Reheat treatment of rejected cylinders is not authorized.

(4) Cylinders with fiber damage (cuts, abrasions, etc.) that exceed Level 1 type damage as defined in CGA Pamphlet C-6.2 and meet the following depth and length criteria are considered to have Level 2 damage:

a. Depth - Damage that upon visual inspection is seen to penetrate the outer fiberglass layer but does not expose the carbon layer beneath, or that has a measured depth of greater than 0.005 inches and less than 0.045 inches for cylinders with an outside diameter greater than 7.5 inches or less than 0.035 inches for cylinders 7.5 inches or less in outside diameter;

b. Length - Damage that has a maximum allowable length of:

Region	Direction of fiber damage	Maximum length of damage
Cylinder sidewall and domes	Transverse to fiber direction (longitudinal direction)	20% of the length of the straight sidewall section of the cylinder

Cylinder sidewall and domes	In the direction of the fiber (circumferential direction)	20% of the length of the straight sidewall section of the cylinder
-----------------------------	---	--

(5) Cylinders with damage that meet the Level 2 criteria must be rejected. Retesters must contact the cylinder manufacturer in the event that damage is questionable based on this criteria. Repair of rejected cylinders is authorized for Level 2 type damage. Repairs must be made in accordance with CGA pamphlet C-6.2, prior to the hydrostatic pressure test. Repairs must be evaluated after the hydrostatic test.

(6) Cylinders that have direct fiber damage that penetrates through the outer fiberglass layer and into the carbon layer, or that have a measured damage depth of greater than the Level 2 maximum stated in (5)(a) above are considered to have Level 3 type damage. Cylinders that have damage with depth meeting Level 2, but length exceeding the Level 2 maximum are considered to have Level 3 type damage. Cylinders with Level 3 type damage are not authorized to be repaired, and must be condemned.

(7) A hydrostatic retest may be repeated as provided for in § 173.34(e)(4), only two such retests are permitted. Pressurization prior to the official hydrostatic test for the purpose of a systems check must not exceed 85% of the required test pressure.

c. OPERATIONAL CONTROLS -

(1) Cylinders manufactured under this exemption are not authorized for use fifteen (15) years after the date of manufacture.

(2) Cylinders may not be used for underwater breathing purposes.

(3) Cylinders used in oxygen service must conform with § 173.302(a)(5)(i)-(iv). Cylinders used in nitrous oxide service must conform with § 173.304(a)(4).

(4) A cylinder that has been subjected to fire may not be returned to service.

(5) Transportation of flammable gases is not authorized aboard passenger-carrying aircraft or passenger vessel.

(6) Transportation of oxygen is only authorized when in accordance with § 172.102(c)(2) Special Provision A52 and §§ 175.85(h) and (i).

(7) Cylinders must be packaged in accordance with § 173.301(k).

8. SPECIAL PROVISIONS:

a. In accordance with the provisions of Paragraph (b) of § 173.22a, persons may use the packaging authorized by this exemption for the transportation of the hazardous materials specified in paragraph 6, only in conformance with the terms of this exemption.

b. A person who is not a holder of this exemption, but receives a package covered by this exemption, may reoffer it for transportation provided no modifications or changes are made to the package and it is offered for transportation in conformance with this exemption and the HMR.

c. A current copy of this exemption must be maintained at each facility where the package is offered or reoffered for transportation.

d. A current copy of this exemption must be maintained at each facility where the package is manufactured under this exemption. It must be made available to a DOT representative upon request.

e. Each packaging manufactured under the authority of this exemption must be either (1) marked with the name of the manufacturer and location (city and state) of the facility at which it is manufactured or (2) marked with a registration symbol designated for a specific manufacturing facility.

f. The cylinders described in this exemption are authorized only for normal transportation as an article of commerce i.e., the movement of hazardous materials packages from consignor to consignee.

g. When transported by cargo vessel, flammable gases covered by this exemption must be packed within a closed freight container of steel construction.

9. MODES OF TRANSPORTATION AUTHORIZED: Motor vehicle, rail freight, cargo vessel, passenger vessel, cargo aircraft and passenger-carrying aircraft (see paragraph 7.(c).(5) and (6) for restrictions).
10. MODAL REQUIREMENTS:
- a. A current copy of this exemption must be carried aboard each cargo vessel, passenger vessel or aircraft used to transport packages covered by this exemption.
- b. The shipper must furnish a copy of this exemption to the air carrier before or at the time the shipment is tendered.
11. COMPLIANCE: Failure by a person to comply with any of the following may result in suspension or revocation of this exemption and penalties prescribed by the Federal hazardous materials transportation law, 49 U.S.C. 5101 et seq:
- o All terms and conditions prescribed in this exemption and the Hazardous Materials Regulations, Parts 171-180.
  - o Registration required by § 107.601 et seq., when applicable. Each "Hazmat employee", as defined in § 171.8, who performs a function subject to this exemption must receive training on the requirements and conditions of this exemption in addition to the training required by §§ 172.700 through 172.704.

No person may use or apply this exemption, including display of its number, when this exemption has expired or is otherwise no longer in effect.

12. REPORTING REQUIREMENTS: The carrier is required to report any incident involving loss of packaging contents or packaging failure to the Associate Administrator for Hazardous Materials Safety (AAHMS) as soon as practicable. (Sections 171.15 and 171.16 apply to any activity undertaken under the authority of this exemption.) In addition, the holder(s) of this exemption must also inform the AAHMS, in writing, as soon as practicable of any incidents involving the package and shipments made under this exemption.

Continuation DOT-E 10945 (13th Rev.)

Page 7

Issued in Washington, D.C.



SEP 9 2002

fr

Robert A. McGuire  
Associate Administrator for  
Hazardous Materials Safety

(DATE)

Address all inquiries to: Associate Administrator for Hazardous  
Materials Safety, Research and Special Programs Administration,  
Department of Transportation, Washington, D.C. 20590.  
Attention: DHM-31.

Copies of this exemption may be obtained by accessing the  
Hazardous Materials Safety Homepage at  
<http://hazmat.dot.gov/exemptions> Photo reproductions and legible  
reductions of this exemption are permitted. Any alteration of  
this exemption is prohibited.

PO: SS/AM





U.S. Department  
of Transportation  
**Research and  
Special Programs  
Administration**

400 Seventh St., S.W.  
Washington, D.C. 20590

**DEC 11 2001**

DOT-E 10970  
(FIFTH REVISION)

EXPIRATION DATE: November 30, 2003

(FOR RENEWAL, SEE 49 CFR § 107.109)

1. GRANTEE: Luxfer Gas Cylinders  
Riverside, California
2. PURPOSE AND LIMITATION: This exemption authorizes the manufacture, mark and sale of non-DOT specification fiber reinforced plastic (FRP) full composite (FC) cylinders for the transportation in commerce of certain compressed gases, and provides no relief from any regulation other than as specifically stated.
  - b. The safety analyses performed in development of this exemption only considered the hazards and risks associated with transportation in commerce.
3. REGULATORY SYSTEM AFFECTED: 49 CFR Parts 106, 107 and 171-180.
4. REGULATIONS FROM WHICH EXEMPTED: 49 CFR §§ 173.302(a)(1), 173.304(a), (d), and 175.3 in that a non-DOT specification cylinder is not authorized, except as prescribed herein.
5. BASIS. This exemption is based on the application of Luxfer Gas Cylinders dated November 9, 2001 submitted in accordance with § 107.109.

Continuation of DOT-E 10970 (5th Rev.)

Page 2

6. HAZARDOUS MATERIALS (49 CFR § 172.101):

DEC 11 2001

Hazardous materials description/ proper shipping name	Hazard Class or Division	Identifica tion Number	Packing Group
Air compressed (containing up to 39% by volume oxygen)	2.2	UN 1002	N/A
Carbon dioxide	2.2	UN 1013	N/A
Helium, compressed	2.2	UN 1046	N/A
Nitrogen, compressed	2.2	UN 1066	N/A
Oxygen, compressed	2.2	UN 1072	N/A
Methane, compressed	2.1	UN 1971	N/A

7. SAFETY CONTROL MEASURES:

a. PACKAGING: Packaging prescribed is a non-DOT specification fiber reinforced plastic (FRP) full composite (FC) aluminum cylinder made in conformance with the following:

(i) Luxfer USA's design drawing C-1060-30T69-A4A dated 6-33-92, and the report of Design Qualification Tests contained on file with the Office of Hazardous Materials Exemptions and Approvals (OHMEA), and

(ii) DOT FRP-1 Standard, Revision 2, dated February 15, 1987, (§ 178.AA) contained in Appendix A of this exemption, except as follows:

§ 178.AA-2 Type, size and service pressure.

Type 3FC cylinder consisting of resin impregnated continuous filament windings in helical and circumferential directions over a seamless aluminum liner made in compliance with § 178.AA-6; not over 200 pounds water capacity; and a service pressure of at least 900 psi but not greater than 5000 psi.

§ 178.AA-4 Duties of the Inspector.

DEC 11 2001

(a) Verify conformance to the requirements in this exemption and to DOT FRP-1 Standard Revision 2, dated February 15, 1987.

(b) Verify conformance of aluminum liner with § 178.AA-6. Verify conformance of the filament and resin system components with the requirements specified in § 178.AA-5 of this exemption.

(c) thru (g) \* \* \*

§ 178.AA-5 Authorized Materials and Identification of materials.

(a) Aluminum liner must be 6061 alloy of T6 temper made from seamless drawn tubing.

(b) Filament material must be Kevlar 49™-8520 Denier, and glass hybrid construction. The filaments must be tested in accordance with ASTM-D2343-67(85) for strand strength and must have strand strength of 400,000 psi minimum. For roving denier determination, the filament material must be tested in accordance with ASTM D3317-74 and must be of at least 90% of the specified nominal value for the rovings. A manufacturer's certified test results for the rovings used in production may be used in lieu of testing.

(c) thru (e) \* \* \*

b. MARKING: Each cylinder must be marked as prescribed in § 178.AA-15

8. SPECIAL PROVISIONS.

a. In accordance with the provisions of Paragraph (b) of § 173.22a, persons may use the packaging authorized by this exemption for the transportation of the hazardous materials specified in paragraph 6, only in conformance with the terms of this exemption.

b. A person who is not a holder of this exemption, but receives a package covered by this exemption, may reoffer it for transportation provided no modifications or changes are made to the package and it is offered for transportation in conformance with this exemption and the HMR.

c. A current copy of this exemption must be maintained at each facility where the package is offered or reoffered for transportation.

d. Each packaging manufactured under the authority of this exemption must be marked with the a registration symbol designated by the Office of Hazardous Materials Exemptions and Approvals for a specific manufacturing facility.

e. A current copy of this exemption must be maintained at each facility where the package is manufactured under this exemption. It must be made available to a DOT representative upon request.

f. Cylinders may not be used for underwater breathing purposes.

g. Cylinders used in oxygen service must conform with § 173.302(a)(5)(i) through (a)(5)(iv).

h. Cylinder service life may not exceed 15 years from the date of manufacture as marked on the cylinder.

i. Each cylinder must be reinspected and hydrostatically retested every three years in accordance with § 173.34(e)(13), as prescribed for DOT 3HT specification cylinders, except that the rejection elastic expansion does not apply and the permanent volumetric expansion may not exceed 5 percent of the total volumetric expansion at test pressure. Retest dates must be stamped on the exposed metallic surface of the cylinder neck or marked on a label securely affixed to the cylinder and overcoated with epoxy near the original test date. Reheat treatment or repair of rejected cylinders is not authorized. When a hydrostatic retest is repeated as provided for in § 173.34(e)(3), only two such retests are permitted.

j. No person may perform inspection and testing of cylinders subject to this exemption unless that person (1) holds a current copy of this exemption at the location of such inspection and testing, and (2) complies with all the terms and conditions of this exemption. The marking of the retester's symbol on the cylinders certifies compliance with all of the terms and conditions of this exemption.

k. A cylinder that has been subjected to fire may not be returned to service.

l. Transportation of flammable gases is not authorized aboard cargo vessel or aircraft.

- m. Transportation of oxygen is only authorized when in accordance with § 172.102(c)(2) Special Provision A52, and § 175.85(h) and (i).
- n. Cylinders must be packaged in accordance with § 173.301(k).
- o. A current copy of this exemption, in its current status, must be maintained at each manufacturing facility at which this packaging is manufactured and must be made available to a DOT representative upon request.
- p. The cylinders described in this exemption are authorized only for normal transportation as an article of commerce i.e., the movement of hazardous materials packages from consignor to consignee.
- q. Filling requirements are subject to all terms contained in § 173.302 for 3AL specification cylinders.
9. MODES OF TRANSPORTATION AUTHORIZED. Motor vehicle, rail freight, cargo vessel, passenger carrying aircraft, and cargo-aircraft only. (See paragraphs 8(l) and 8(m) of this exemption.)
10. MODAL REQUIREMENTS: A current copy of this exemption must be carried aboard each cargo vessel or aircraft used to transport packages covered by this exemption. The shipper must furnish a current copy of this exemption to the air carrier before or at the time the shipment is tendered.
11. COMPLIANCE. Failure by a person to comply with any of the following may result in suspension or revocation of this exemption and penalties prescribed by the Federal hazardous materials transportation law, 49 U.S.C. 5101 et seq.:
- All terms and conditions prescribed in this exemption and the Hazardous Materials Regulations, Parts 171-180.
  - Registration required by § 107.601 et seq., when applicable.


Each "Hazmat employee", as defined in § 171.8 who performs a function subject to this exemption must receive training on the requirements and conditions of this exemption in addition to the training required by §§ 172.700 through 172.704.

No person may use or apply this exemption, including display of its number, when the exemption has expired or it is

otherwise no longer in effect.

12. REPORTING REQUIREMENTS. The carrier is required to report any incident involving loss of packaging contents or packaging failure to the Associate Administrator for Hazardous Materials Safety (AAHMS) as soon as practicable. (Sections 171.15 and 171.16 apply to any activity undertaken under the authority of this exemption.) In addition, the holder(s) of this exemption must inform the AAHMS, in writing, of any incidents involving the package and shipments made under the terms of this exemption.

Issued in Washington, D.C.:



*For* Robert A. McGuire  
Associate Administrator  
for Hazardous Materials Safety

DEC 11 2001

(DATE)

Address all inquiries to: Associate Administrator for Hazardous Materials Safety, Research and Special Programs Administration, Department of Transportation, Washington, D.C. 20590.  
Attention: DHM-31.

The original of this exemption is on file at the above office. Photo reproductions and legible reductions of this exemption are permitted. Any alteration of this exemption is prohibited.

Copies of exemptions may be obtained from the AAHMS, U.S. Department of Transportation, 400 7th Street, SW, Washington, DC 20590-0001, Attention: Records Center, 202-366-05046.

PO: AM



U.S. Department  
of Transportation  
**Research and  
Special Programs  
Administration**

400 Seventh St., S.W.  
Washington, D.C. 20590

**JAN 28 2002**

DOT-E 8162  
(THIRTEENTH REVISION)

EXPIRATION DATE: December 31, 2003

(FOR RENEWAL, SEE 49 CFR § 107.109)

1. GRANTEE: Structural Composites Industries  
Pomona, California
2. PURPOSE AND LIMITATIONS:
  - a. This exemption authorizes the manufacture, mark, sale and use of non-DOT specification fiber reinforced plastic cylinders conforming with all regulations applicable to the DOT specification FRP-1 Standard, except as specified herein, for use as an equipment component aboard aircraft and marine craft. This exemption provides no relief from the Hazardous Materials Regulations (HMR) other than as specifically stated herein.
  - b. The safety analyses performed in development of this exemption only considered the hazards and risks associated with transportation in commerce. The safety analyses did not consider the hazards and risks associated with consumer use, use as a component of a transport vehicle or other device, or other uses not associated with transportation in commerce.
3. REGULATORY SYSTEM AFFECTED: 49 CFR Parts 106, 107 and 171-180.
4. REGULATIONS FROM WHICH EXEMPTED: 49 CFR §§ 173.302(a)(1), 173.304(a)(1) and 175.3 that non-specification cylinders are not authorized, except as specified herein.
5. BASIS: This exemption is based on the application of Structural Composites Industries, dated November 30, 2001, submitted in accordance with § 107.109.

JAN 28 2002

6. HAZARDOUS MATERIALS (49 CFR § 172.101):

Proper Shipping Name/ Hazardous Material Description	Hazard Class/ Division	Identi- fication Number	Packing Group
Air, compressed	2.2	UN1002	N/A
Argon, compressed	2.2	UN1006	N/A
Bromotrifluoromethane, R13B1	2.2	UN1009	N/A
Carbon dioxide	2.2	UN1013	N/A
Compressed gas, n.o.s.	2.2	UN1956	N/A
Helium, compressed	2.2	UN1046	N/A
Nitrogen, compressed	2.2	UN1066	N/A
Oxygen, compressed	2.2	UN1072	N/A

7. SAFETY CONTROL MEASURES:

a. PACKAGING - Packaging prescribed is a non-DOT specification fiber reinforced plastic (FRP) full composite (FC) cylinder in full compliance with SCI Report 76188 on file with the Office of Hazardous Materials Exemptions and Approvals (OHMEA) and with DOT FRP-1 Standard Revision 2 (178.AA) dated February 15, 1987, except as follows:

§ 178.AA-4 Duties of Inspector.

\* \* \*

(b) Add an additional sentence which reads: In lieu of testing for filament material properties by the exemption holder, a certificate by the filament manufacturer is acceptable provided that the procurement document specifies strength and quality requirements and that the supplied material is certified to those requirements.

§ 178.AA-5 Authorized material and identification of material.

(a) Aluminum liner must be 6061 alloy and T6 temper.

(b) Filament material must be Kevlar 49 in compliance with proposed aerospace materials specification (AMS)



3901. Filament must be tested in accordance with ASTM D 2343 for strand strength, and ASTM D 3317 for Denier.

(1) Strand strength must be 450,000 psig minimum.

(2) Denier must be at least 90 percent of the nominal value specified in AMS 3901. Denier of roving may be certified by the filament manufacturer.

\* \* \* \* \*

§ 178.AA-10 Pressure relief devices and protection for valves, relief devices, and other connections.

(a) Pressure relief devices and protection for valves and other connections must be in compliance with §§ 173.34(d), 173.301(g), and 178.AA-18(g) of this exemption. However, only § 178.AA-18(g) may be used as the measure of relief device adequacy.

\* \* \* \* \*

§ 178.AA-12 Destructive tests.

\* \* \*

(b) Applies except that the rate of cycling may not exceed 10 cycles per minute.

\* \* \* \* \*

§ 178.AA-13 Acceptable results of tests.

(a) thru (c) \* \* \*

(d) Burst test.

(1) Burst pressure shall be at least 3 times the service pressure and in no case less than the value necessary to meet the stress criteria of 178.AA-7(b). Failure must initiate in the cylinder sidewall. Cylinders with marked service pressure not exceeding 2200 psi containing liquefied gas must remain in one piece. Actual burst pressure must be recorded.

§ 178.AA-18 Design qualification tests.

(a) thru (c) \* \* \*

(d) Applies except that the rate of cycling may not exceed 10 cycles per minute.

(e) \* \* \*

(1) \* \* \*

(2) Burst pressure must be at least 3 times the service pressure and in no case less than the value necessary to meet the stress criteria of 178.AA-7(b). Failure must initiate in the sidewall. Cylinders with marked service pressure not exceeding 2200 psi containing liquefied gas must remain in one piece. Actual burst pressure must be recorded.

(f) Gunfire test. One representative cylinder charged with air or nitrogen to service pressure shall be impacted by a 0.30 caliber armor piercing projectile having a velocity of approximately 2800 feet per second. Cylinders shall be so positioned that projectile impact point is in the bottom cylinder wall aimed to exit at cylinder sidewall, or impact point is on the cylinder sidewall at a 90° angle to the cylinder sidewall axis. Distance from firing location to test cylinder not to exceed 50 yards. Tested cylinder shall reveal no evidence of fragmentation failure. Any tear beyond 3 inches from the entrance or exit hole is cause for rejection. Approximate size of entrance and exit openings must be recorded.

\* \* \* \* \*

b. TESTING - Each cylinder must be reinspected and hydrostatically retested every three years in accordance with § 173.34(e) as prescribed for DOT 3HT cylinders, except that the rejection elastic expansion criterion does not apply, and permanent volumetric expansion must not exceed 5 percent of total volumetric expansion at test pressure. Retest dates must be steel stamped on the outer exposed metallic surface of the cylinder neck, or marked on a label securely affixed to the cylinder and overcoated with epoxy. Reheat treatment or repair of rejected cylinders not authorized.

JAN 28 2002

8. SPECIAL PROVISIONS:

a. In accordance with the provisions of Paragraph (b) of § 173.22a, persons may use the packaging authorized by this exemption for the transportation of the hazardous materials specified in paragraph 6, only in conformance with the terms of this exemption.

b. A person who is not a holder of this exemption, but receives a package covered by this exemption, may reoffer it for transportation provided no modification or change is made to the package or its contents and it is offered for transportation in conformance with this exemption and the HMR.

c. A current copy of this exemption must be maintained at each facility where the package is offered or reoffered for transportation.

d. Each packaging manufactured under the authority of this exemption must be marked with a registration symbol designated by the Office of Hazardous Materials Exemptions and Approvals for a specific manufacturing facility.

e. A current copy of this exemption must be maintained at each facility where the package is manufactured under this exemption. It must be made available to a DOT representative upon request.

f. No cylinder is authorized 15 years after the date of manufacture.

g. Cylinders are authorized only for use as equipment components aboard aircraft or marine craft specifically identified to the OHMEA.

h. Cylinder must be packaged in accordance with § 173.301(k).

i. Cylinders subjected to action of fire may not be placed in service.

j. Cylinders used in oxygen service must be in compliance with §§ 173.302(a)(5)(i) thru (a)(5)(iv).

k. Transportation of oxygen is only authorized by aircraft when in accordance with § 172.102(c)(2) Special Provision A52 and §§ 175.85(h) and (i).

9. MODES OF TRANSPORTATION AUTHORIZED: Motor vehicle, rail freight, cargo vessel, cargo aircraft only, and passenger-carrying aircraft (see paragraph 8.k. for restrictions).
10. MODAL REQUIREMENTS: A current copy of this exemption must be carried aboard each cargo vessel or aircraft used to transport packages covered by this exemption. The shipper must furnish a copy of this exemption to the air carrier before or at the time the shipment is tendered.
11. COMPLIANCE: Failure by a person to comply with any of the following may result in suspension or revocation of this exemption and penalties prescribed by the Federal hazardous materials transportation law, 49 U.S.C. 5101 et seq:
- o All terms and conditions prescribed in this exemption and the Hazardous Materials Regulations, Parts 171-180.
  - o Registration required by § 107.601 et seq., when applicable.

Each "Hazmat employee", as defined in § 171.8, who performs a function subject to this exemption must receive training on the requirements and conditions of this exemption in addition to the training required by §§ 172.700 through 172.704.

No person may use or apply this exemption, including display of its number, when this exemption has expired or is otherwise no longer in effect.

12. REPORTING REQUIREMENTS: The carrier is required to report any incident involving loss of packaging contents or packaging failure to the Associate Administrator for Hazardous Materials Safety (AAHMS) as soon as practicable. (Sections 171.15 and 171.16 apply to any activity undertaken under the authority of this exemption.) In addition, the holder(s) of this exemption must also inform the AAHMS, in writing, as soon as practicable of any incidents involving the package and shipments made under this exemption.

Issued in Washington, D.C.



*fa*  
Robert A. McGuire  
Associate Administrator for  
Hazardous Materials Safety

JAN 28 2002

(DATE)

Continuation of DOT-E 8162 (13th Rev.)

JAN 28 2002

Page 7

Address all inquiries to: Associate Administrator for Hazardous Materials Safety, Research and Special Programs Administration, Department of Transportation, Washington, D.C. 20590.  
Attention: DHM-31.

Copies of this exemption may be obtained by accessing the Hazardous Materials Safety Homepage at <http://hazmat.dot.gov/exemptions> Photo reproductions and legible reductions of this exemption are permitted. Any alteration of this exemption is prohibited.

PO: KFW

**APPENDIX A**  
**BASIC REQUIREMENTS FOR FULLY WRAPPED**  
**CARBON-FIBER REINFORCED**  
**ALUMINUM LINED CYLINDERS (DOT-CFFC)**

**DATE: NOVEMBER 2000 (FOURTH REVISION)**

**TABLE OF CONTENTS:**

CFFC-1	SCOPE
CFFC-2	TYPE, SIZE, AND SERVICE PRESSURE
CFFC-3	SERVICE LIFE
CFFC-4	INSPECTION BY WHOM AND WHERE
CFFC-5	DUTIES OF INSPECTOR
CFFC-6	AUTHORIZED MATERIAL AND IDENTIFICATION OF MATERIAL
CFFC-7	DESIGN CRITERIA
CFFC-8	OPENINGS, VALVES, AND PRESSURE RELIEF DEVICES
CFFC-9	DESIGN TYPE AND AUTHORIZATION
CFFC-10	DESIGN QUALIFICATION TESTS
CFFC-11	QUALIFICATION REQUIREMENTS FOR DESIGN CHANGE
CFFC-12	MANUFACTURING, QUALITY ASSURANCE AND LOT QUALIFICATION TESTS
CFFC-13	PRODUCTION TESTS
CFFC-14	MARKING
CFFC-15	INSPECTOR'S REPORTS
CFFC-16	RETENTION OF REPORTS
*	Revised Section or Part (1 <sup>st</sup> REVISION, JULY 1997)
**	Revised Section or Part (2 <sup>nd</sup> REVISION, JUNE 1998)
***	Revised Section or Part (3 <sup>rd</sup> REVISION, MARCH 1999)
****	Revised Section or Part (4 <sup>th</sup> REVISION, NOVEMBER 2000)
	##
CFFC-1	<b>SCOPE:</b> These basic requirements (DOT-CFFC) cover design, manufacture, and performance requirements for cylinders made of a seamless aluminum liner over wrapped with structural layers of filament wound carbon fiber and epoxy composite material.

CFFC-2 **TYPE, SIZE AND SERVICE PRESSURE:**

The CFFC cylinder is a seamless aluminum alloy liner wound with carbon fiber and glass fiber reinforced plastic full composite layers and subjected to an autofrettage pressure. Carbon filament wound and epoxy layers are the predominant pressure load bearing elements. An outer glass filament wound and epoxy layer provides damage protection. A galvanic corrosion protection layer is required for the aluminum liner. An inner glass filament wound and epoxy layer is allowed for galvanic corrosion protection. Together, the inner and outer glass filament layers must carry less than 15 percent of the total pressure load at the minimum required burst pressure.

The winding pattern may be a combination of helical (including near longitudinal) and hoop. Layers made up of more than one type of fibers are not authorized.

The maximum permitted water capacity may not exceed 90.7 liters (200 pounds).

The marked service pressure may not exceed 34,474 kPa (5000 psi) at a reference temperature of 21.1 °C (70 °F). The test pressure is 5/3 times the design service pressure. The cylinder must have a minimum safety factor (burst/service pressure ratio) of 3.4.

CFFC-3 **SERVICE LIFE:** Cylinder service life is 15 years from the date of manufacture. The Associate Administrator for Hazardous Materials Safety (AAHMS) may approve an extension of cylinder service life up to a total service life of 30 years. A service life extension approval is made by modification to the exemption authorizing cylinder construction. Approvals of service life extension will be addressed under the following procedures:

1. The cylinder manufacturer must submit a Service Life Extension Plan that includes: a cylinder life cycle analysis; an in-service inspection and testing program to monitor and validate the cylinder life cycle analysis; and a proposal for the periodic reporting of data to the AAHMS. This Plan must be submitted as a part of the original exemption application.
2. The in-service inspection and testing program must begin within one year of the date the exemption is granted.

3. The manufacturer must submit a final report based on data gathered during the in-service inspection and testing program, on cylinders with service lives up to 12 years. This report must be submitted to the AAHMS no more than 13 years after the date the original exemption is granted.

4. The AAHMS will make a decision to approve or reject a service life extension based on the review of the final report. The manufacturer will be notified of the decision within 180 days after the AAHMS receives the final report.

\*\*

CFFC-4

**INSPECTION BY WHOM AND WHERE:** Inspection and verification must be performed by an independent inspection agency approved in writing by the Associate Administrator for Hazardous Materials Safety (AAHMS) in accordance with the Code of Federal Regulations, 49 CFR 173.300a. Chemical analysis must be approved for each procurement batch in accordance with 49 CFR Subchapter C Section 173.300b. Applicable fiber strength properties must be verified in accordance with CFFC-6(b) and approved by the independent inspector for each procurement batch.

CFFC-5

**DUTIES OF INSPECTOR:** The independent inspector shall perform the following verification procedures to ensure that each cylinder manufactured conforms with the design and performance parameters set forth for that cylinder.

(a) Obtain and retain copies of design calculations, drawings, material certifications, and approval documents as applicable to each design type.

\*\*\*\*

(b) Determine that all materials and components comply with the provisions of this standard. Except when stated otherwise, a material identified by the materials or component manufacturer's certified statement as to meeting the procurement specification(s) is acceptable.

(c) Verify the chemical composition of each heat of liner material either by analysis or by obtaining the materials manufacturer's certified analysis. A certification by the cylinder manufacturer indicating compliance with the above requirement is acceptable provided (i) the certification is verified by a check analysis on one sample liner taken out of each lot of 200 or less liners successively produced, and (ii) the



traceability of that material to its manufacturer is established.

(d) Verify all fiber materials for conformance with the cylinder manufacturer's material specification(s), and for uniform and consistent quality.

(e) Verify all resin materials, and other chemicals for conformance with the cylinder manufacturer's material specification(s), and for uniform and consistent quality.

(f) Verify liners with all requirements including dimensions, inner surface smoothness, heat treatment, threads, and corrosion protection.

(g) Verify filament winding and curing procedures.

(h) Verify cylinders for conformance with all requirements including marking, dimensions, inner surface finish, heat treatment, threads, and galvanic corrosion protection in accordance with manufacturer's specifications and drawings.

\*\*\*\*

(i) Witness all tests and pressurization on completed cylinders, obtain copies of all test results and certifications; report volumetric capacity, elastic expansion, and total expansion at autofrettage stage and subsequent test pressure, liner weight, and the completed cylinder weight.

(j) Complete inspector's reports as prescribed in CFFC-15 of this standard. Provide a copy of the reports to the cylinder manufacturer and upon request to the purchaser.

(k) Prior to the initial shipment of any specific design or design change, verify that design qualification tests prescribed in CFFC-10 of this standard have been performed with acceptable results.

CFFC-6

**AUTHORIZED MATERIAL AND IDENTIFICATION OF MATERIAL.**

(a) **Liner:** The liner must be a seamless cylinder made of aluminum alloy 6061 of T-6 temper.

(i) The liner may be produced by cold or hot backward extrusion; cold drawing; or from an extruded tube with swaged or spun ends.

(ii) The material composition of the alloy used

must be within the limits prescribed herein:

ELEMENT	ALLOY 6061	
	MIN %	MAX %
Silicon	0.40	0.80
Iron		0.70
Copper	0.15	0.40
Manganese		0.15
Magnesium	0.80	1.20
Chromium	0.04	0.35
Zinc		0.25
Titanium		0.15
Lead		0.005
Bismuth		0.005
Others Each		0.05
Others Total		0.15
Aluminum	Remainder	

(iii) The liner interior surface shall be smooth. Any fold in the neck region due to the forming or spinning process must not be sharp or deep or detrimental to the integrity of the cylinder. Inner surface defects may be removed by machining or other method, provided the metal loss is minimal and the minimum required wall thickness is maintained.

(iv) Liner ends must be concave to pressure.

(v) Prior to any test, all cylinders must be subjected to a solution heat treatment and aging heat treatment appropriate for aluminum alloy 6061. The process must produce liners of uniform temper and properties.

(vi) The limits for the mechanical properties of alloy 6061 T6 temper prior to filament winding shall be as follows:

<u>6061-T6</u>	
Yield Strength (Min)	241,316 kPa

		(35,000 psi)
	Tensile Strength (Min)	262,001 kPa
		(38,000 psi)
****	Elongation 5.1 cm(2"gage)(Min)	14%
	Elongation (24t X 6t)	10%

(vii) The outer surface of each liner must be protected from any galvanic corrosion that may occur due to dissimilar materials (aluminum and carbon fibers) in contact. A suitable polymer coating or glass-fiber/epoxy composite layer may be used for this purpose.

(viii) Physical tests. To determine yield strength, tensile strength and elongation of the aluminum liner material. Applies to aluminum liner only.

(A) Required on 2 specimens cut from one liner taken at random out of each lot of 200 liners or less. A "lot" means a group of cylindrical liners successively produced having the same: size and configuration, specified material of construction, process of manufacture and heat treatment process conditions.

(B) Specimens must be: Gauge length of 5.1 cm (2 inches) with width not over 3.8 cm (1-1/2 inches); or gauge length of 4 times the specimen diameter (4D bar); a specimen with gauge length at least 24 times the thickness with the width not over 6 times the thickness is also authorized when the liner wall is not over 0.48 cm (3/16 inch) thick. The specimen, exclusive of grip ends, must not be flattened. Grip ends may be flattened to within 2.5 cm (one inch) of each end of the reduced section. When the size of the liner does not permit securing straight specimens, the specimens may be taken in any location or direction and may be straightened or flattened cold and by pressure only, not by blows. When such specimens are used, the inspector's report must show that the specimens were so taken and prepared. Heating of specimens for any purpose is not authorized.

(C) The yield strength in tension shall be the stress corresponding to a permanent

strain of 0.2 percent of the gauge length.

(1) The yield strength shall be determined by the "offset" method as prescribed by ASTM Standard E8-78.

(2) For the purpose of strain measurement, the initial strain shall be set while the specimen is under a stress of 41,369 kPa (6,000 psi), the strain indicator reading being set at the calculated corresponding strain.

(3) Cross-head speed of the testing machine shall not exceed 0.32 cm (1/8 inch) per minute during yield strength determination.

(b) **Filament materials:**

(i) Carbon fibers: Must be polyacrylonitrile (PAN) based carbon fiber tows having mechanical properties meeting a specified procurement document. The mechanical properties of the fibers must be established for each procurement batch by testing in accordance with ASTM D-4018-93 and have a minimum strand strength specified in the cylinder manufacturer's material specification document. The tensile strength may not exceed 5,171,068 kPa (750,000 psi), the modulus of elasticity may not exceed 290 million kPa (42 million psi), and the strain to failure may not be less than 1 percent.

\*\*\*\*

(ii) Glass fibers: Only type S and type E glass fibers are authorized. Filaments must be tested in accordance with ASTM D-2343-95 and have a minimum strand strength as follows:

Type S Glass ----2,757,903 kPa (400,000 psi)

Type E-Glass ----1,378,951 kPa (200,000 psi)

(iii) Fiber strength: In lieu of testing for fiber strength by the cylinder manufacturer, a certificate by the fiber manufacturer is acceptable provided that the cylinder manufacturer's material specification document specifies strength and quality requirements and that the supplied material meets those requirements.

\*\*\*\*

(c) **Resin matrix materials:** Resin matrix systems must be epoxy or modified epoxy type having a pot life compatible with the filament winding process used. The resin matrix system selected must have sufficient ductility so that cracking of the resin matrix system does not occur during the manufacturing of the cylinder or during normal operation for the useful life of the cylinder. The cylinder manufacturer shall verify that each batch of resin/hardener mix is of satisfactory quality and properties within specified tolerances, and shall maintain such records as needed to be able to identify the cylinders manufactured from each batch of materials.

(d) **Overwrapped:** The composite overwrap shall be formed by layers of continuous fibers in a matrix. Helical or near longitudinal windings must cover the entire surface of the liner. When circumferential layers are interspersed for strengthening the side wall, physical discontinuity between the layers must be minimized.

(i) Co-mingled fibers are not authorized. Each layer may contain one type of fibers only.

(ii) Both wet winding and pre-impregnated filament winding is authorized.

(iii) For each design type cylinder the following parameters shall be defined and recorded:

- (A) Number of strands used
- (B) Winding tension
- (C) Winding pattern (angles, pitch and order of layers)
- (D) Winding speed
- (E) Curing cycle
- (F) Resin content
- (G) Quality assurance procedures

CFFC-7 **DESIGN CRITERIA:**

\*\*\*\*

(a) **General:** The design and stress analysis of a CFFC cylinder is complex because of the varying load bearing layers, the varying orientation and thickness of composite layers, and the necessity that the aluminum liner is subjected to above yield strains at the time of autofrettage pressure cycle.

A reliable model of the cylinder must be used in order

to calculate the maximum stress at any point in the liner and fibers; and load distribution between liner and fibers at zero pressure, service pressure, test pressure, and burst pressure. For these purposes, as a minimum, the model used to analyze the cylinder body must be based on thin shell theory, must account for non-linear material behavior and nonlinear geometric changes, and it must account for both circumferential and longitudinal pressure stresses. Only the cylinder body must be analyzed. Note: maximum stresses in the cylinder ends must always be less than the maximum stresses in the cylinder body to pass burst tests.

This analysis will require that finite element techniques be used to satisfactorily analyze the stresses in the fibers. The model and analysis procedure must be specifically described and documented. The maximum calculated tensile stress in any fibers (carbon or glass) may not exceed 30 percent of the fiber stress corresponding to the minimum required burst pressure.

(b) Stress Distribution requirements:

(i) The maximum calculated tensile stress at any point in the liner at the service pressure may not exceed 60 percent of the yield strength of the liner as measured according to section 6(a) of this document. The compressive stress in the sidewall of the liner at zero pressure must be at least 60 percent but no more than 95 percent of the minimum yield strength of the liner material as determined per CFFC 6(a)(viii).

(ii) Glass fibers used for galvanic corrosion protection of the liner and for damage protection of the cylinder must be such that its net load sharing capability may not exceed 15 percent of the total pressure load in the cylinder at minimum required burst pressure.

(iii) The maximum fiber stress at service pressure of the carbon fibers or glass fibers may not exceed 30 percent of the fiber stress corresponding to the minimum required burst pressure.

(iv) The burst failure mode shall initiate in the cylinder side wall.

CFFC-8 **OPENINGS, VALVES, AND PRESSURE RELIEF DEVICES :**(a) **Openings :**

(i) Openings are permitted on heads only. The centerline of the openings must coincide with the centerline of the cylinder.

(ii) Threads must be clean cut, even, without checks, and must be designed in compliance with the requirements of the Federal Standard FED-STD-H28, Appendix A5.

(iii) Tapered threads are not permitted.

(iv) Straight threads having at least 6 threads must have a calculated factor of safety in shear of at least 10 at the test pressure for the cylinder. The threads must extend completely through the neck.

(b) **Valves, pressure relief devices, connections, and valve protection :**

Selection of valves and pressure relief devices must conform to the requirements in Compressed Gas Association (CGA) Pamphlet S-1.1, 1994 edition and must be in compliance with the requirements in 49 CFR 173.34(d) and 173.301(g) except that the adequacy of the pressure relief device is determined by bonfire test as prescribed in CFFC-10. The rated bursting pressure of a rupture disk at ambient temperature must be not less than 83 percent nor more than 100 percent of the cylinder test pressure.

CFFC-9 **DESIGN TYPE AND AUTHORIZATION :**

(a) For each original cylinder design type, an application for a Department of Transportation Exemption shall be submitted in accordance with 49 CFR 107.105. Application may be made for multiple design types in one exemption application, provided there are variations in size and pressure only. An exemption must be granted in order for the cylinder to be authorized for the transportation of hazardous materials.

(b) For each original cylinder design type, detailed drawings showing dimensions, including tolerances, bill of materials, a description of manufacturing and quality assurance procedures, and results of design

qualification tests must be submitted to the Office of Exemptions and Approvals (OHMEA) before first shipment.

(c) A design type means cylinders of the same configuration (diameter, water capacity, service pressure, winding pattern), material specifications, design analysis procedures, manufacturing process, and manufacturing facility.

(d) A cylinder is not considered to be of a new design type, and no additional application or tests are required, if the deviation from the original design type is as follows:

(i) the change in diameter or service pressure is 10 percent or less, or the change in water capacity is 30 percent or less;

(ii) there are minor changes in the manufacturing process, quality assurance procedures, material properties, or winding pattern that have no significant effect on cylinder quality or performance.

(e) Cylinders representing design changes from the original design type (other than those in paragraph (d)) must be subjected to testing in accordance with CFFC-11. The applicant must make a request for modification to the exemption in order for the cylinders representing the design change to be listed as authorized cylinders. Detailed drawings and design qualification test results must be on file with the OHMEA before first shipment.

#### CFFC-10 DESIGN QUALIFICATION TESTS AND ACCEPTABLE TEST RESULTS :

\*\*\*\*

Prior to initial shipment of any cylinder design type, qualification tests as prescribed herein shall have been performed with satisfactory results. For each design type qualification a sufficient number of cylinders shall be produced in a batch to permit all qualification tests to be carried out. Cylinders must be produced using the same materials, manufacturing equipment types, manufacturing processes and quality assurance procedures as used for production. The independent inspector must witness all design qualification tests. From the above batch of cylinders the independent inspector will select cylinders at random for each qualification test.

(a) **Resin System:** The resin system shall be tested on a



sample coupon representative of the composite over wrapped in accordance with ASTM D-2344-89 for water boil shear test. The minimum shear strength may not be less than 34,474 kPa (5000 psi).

\* (b) **Burst Test:** The minimum required burst pressure is 3.4 times the marked service pressure marked on the cylinder. A minimum of three cylinders must be hydrostatically tested in accordance with the following:

(i) **Procedure:** Pressurize each cylinder at a uniform rate up to 3.4 times the marked service pressure marked on the cylinder, and hold at that pressure for a minimum of 60 seconds. The rate of pressurization may not exceed 1,379 kPa (200 psi) per second. Increase the pressure to failure and record the pressure at the onset of failure. Cylinders used in the ambient temperature cycling test may be used for the burst test.

(ii) **Acceptable test results:** In no case may the burst pressure of any cylinder be less than the required minimum burst pressure. The failure initiation must be in the cylindrical part of the cylinders.

(c) **Drop Test:** At a minimum, one empty cylinder, complete with valve but uncharged must be subjected to a drop test from a height of 3 meters (10 feet) onto a concrete surface in accordance with the following:

(i) **Procedure:**

Drop 1: The cylinder shall be dropped vertically onto the end.

Drop 2: The cylinder shall be dropped horizontally onto the sidewall.

Drop 3: The cylinder shall be dropped horizontally onto a 3.8 x 0.48 cm (1½ x 3/16 inch) piece of angle iron, with the included angle in the downward position. The cylinder shall land at right angles to and on the heel edge of the angle iron, impacting approximately in the center of the sidewall.

\*\*\*\*

(ii) **Acceptable test results, if one cylinder tested:** The cylinder must be subjected to 1,000 pressure cycles from not greater than 10 percent

of service pressure and the service pressure at a rate not to exceed 10 cycles per minute. The minimum dwell time in the pressure range between 90 and 100 percent of the service pressure may not be less than 1.2 seconds. The test cylinder must withstand the cycling pressurization test without any evidence of visually observable leakage or damage growth during or after the pressure cycle test. After successfully passing the cycling test, the cylinder must be burst tested in accordance with the procedure described in CFFC-10(b)(i) of this standard. The residual burst strength of the cylinder must be at least 90 percent of the required minimum burst pressure (3.06 times service pressure). The cycling and burst pressure test data must be submitted to the DOT for the information data base.

\*\*\*\*

**(iii) Acceptable test results, if two cylinders tested:** One cylinder must be subjected to 1,000 pressure cycles from not greater than 10 percent of service pressure and the service pressure at a rate not to exceed 10 cycles per minute. The minimum dwell time in the pressure range between 90 and 100 percent of the service pressure may not be less than 1.2 seconds. The test cylinder must withstand the cycling pressurization test without any evidence of visually observable leakage or damage growth during or after the pressure cycle test. After successfully passing the cycling test, the cylinder must be burst tested. The rate of pressurization may not exceed 1,379 kPa (200 psi) per second. Increase the pressure to failure and record the pressure at the onset of failure. The burst pressure must be recorded.

The other cylinder must be burst tested in accordance with with the procedure described in CFFC-10(b)(i) of this standard. The residual burst strength of the cylinder must be at least 90 percent of the required minimum burst pressure (3.06 times service pressure). The cycling and burst pressure test data for both cylinders must be submitted to the DOT for the information data base.

**(d) Ambient temperature cycling pressurization test :**  
At a minimum, two cylinders must be subjected to cycling pressurization tests in accordance with the following:

(i) **Procedure:** Pressurize the cylinder between a pressure not greater than 10 percent of service pressure and the service pressure at a rate not to exceed 10 cycles per minute. The minimum dwell time in the pressure range between 90 and 100 percent of the service pressure may not be less than 1.2 seconds. Each cylinder must be subjected to a minimum of 10,000 cycles. Following the cycling test to service pressure, each cylinder must be subjected to a minimum of 30 pressurization cycles by pressurizing between approximately zero and the minimum required test pressure. The dwell time between 90 and 100 percent of the maximum test pressure may not be less than 1.2 seconds.

\*\*\*\*

(ii) **Acceptable test results:** Each test cylinder must withstand the cycling pressurization test without any evidence of visually observable damage, distortion or leakage. After successfully passing the cycling test, the cylinder must be burst tested in accordance with the procedure described in CFFC-10(b)(i) of this standard. The residual burst strength of the cylinder must be at least 90 percent of the required minimum burst pressure (3.06 times service pressure).

(e) **Environmental cycling tests:** Two cylinders must be cycle tested in accordance with the following:

(i) **Procedure:** The cycling rate may not exceed 10 cycles per minute. The dwell time between 90 and 100 percent of the maximum cycling pressure may not be less than 1.2 seconds:

Step 1. Condition for 48 hours at zero pressure, 60°C (140°F), and 95 percent humidity

Step 2. Pressurize from zero to service pressure for 5000 cycles at 60°C (140°F) or higher, and 95 percent or greater humidity.

\*\*\* Step 3. Stabilize at zero pressure and at ambient conditions. Place in an environmental chamber at minus 51.6°C (minus 60°F) or lower and then pressurize from zero to service pressure. The cylinder shall be subjected to a minimum of 5000 pressurization cycles.

Step 4. Stabilize at zero pressure and at ambient conditions, and then pressurize from zero to test pressure at ambient temperature. The cylinder shall be subjected to a minimum of 30 pressurization cycles.

\*\*\*\*

\* Step 5. After successfully passing the cycling test, the cylinder shall be burst tested in accordance with the procedure described in CFFC-10(b)(i) of this standard.

\*(ii) **Acceptable test results:** Each test cylinder must withstand the cycling pressurization test without any evidence of visually observable damage, distortion or leakage. In addition, the residual burst strength of the cylinder must be at least 90 percent of the required minimum burst pressure (3.06 times service pressure). The outer surface of the liner must show no evidence of corrosion or defects such as cracking, leakage, etc.

(f) **Thermal cycling test:** Two cylinders shall be cycle tested in accordance with the following:

(i) **Procedure:** The cycling rate may not exceed 10 cycles per minute. The dwell time between 90 and 100 percent of the maximum test pressure may not be less than 1.2 seconds.

Step 1. Cycle test at ambient temperature by pressurizing from approximately zero pressure to service pressure for 10,000 cycles.

\*\*\*

Step 2. Pressurize and maintain the cylinder at service pressure and subject the cylinder to a minimum of 20 thermal cycles at each temperature of 93.3°C (200°F) and minus 51.6°C (minus 60°F) maintaining the dwell time at each extreme temperature to a minimum of 10 minutes.

\*\*\*\*

Step 3. After successfully passing the cycling test, the cylinder shall be burst tested in accordance with the procedure described in CFFC-10(b)(i) of this standard.

(ii) **Acceptable test results:** The test cylinder must withstand the thermal cycling test without any evidence of visually observable damage, distortion or leakage. In addition, the residual burst strength of the cylinder must be at least 90 percent of the required minimum burst pressure

(3.06 times service pressure).

(g) **Gunfire test:** One cylinder must be tested in accordance with the following:

(i) **Procedure:** The cylinder must be charged with air or nitrogen to service pressure and shall be impacted by a 0.30 caliber armor piercing projectile having a velocity of about 853.4 meters (2800 feet) per second. The cylinder shall be positioned in such a way that the impact point shall be in the cylinder sidewall at an angle of 45° to the longitudinal axis of the cylinder and aimed to exit the sidewall on the opposite side of the cylinder. The distance from the firing location to the cylinder may not exceed 45.7 meters (150 feet).

(ii) **Acceptable test results:** The cylinder shall not fail by fragmentation. The approximate size of the entrance and exit penetrations shall be recorded.

(h) **Bonfire test:** Two cylinders must be tested in accordance with the following:

(i) **Procedure:** Cylinders must be fitted with the valves and pressure relief devices as specified in CFFC-8 of this standard, set to discharge at a pressure between 83 percent and 100 percent of the cylinder test pressure at ambient conditions. Cylinders must be charged with nitrogen or air to service pressure. The required bonfire test procedure shall be in accordance with the Compressed Gas Association (CGA) Pamphlet CGA C-14-1992. The test shall be performed with the cylinder placed in an upright position. The cylinder shall be exposed to fire until the contents are fully vented.

(ii) **Acceptable test results:** The venting of the gas must be predominantly through the pressure relief device. Cylinders must be intact at the completion of venting.

\*\*\*\* CFFC-11 QUALIFICATION REQUIREMENTS FOR DESIGN CHANGE: Cylinders representative of each design and design change (from the original design) must be subjected to the following qualification tests and stress analysis:

Type of Test or Requirement	Original Design	DESIGN CHANGE						
		Material	Diameter or Service Pressure		Water capacity		Manufac-turing Facility	Liner
		Any Change	10 to 20 percent change	Greater than 20 percent change	30 to 50 percent change	Greater than 50 percent change	Any Change	Reduction in dome or wall thickness
Resin Shear Test	X	X	-	-	-	-	-	-
Cycling-Ambient Temp.	X	X	X	X	X	X	X	X
Cycling-Environmental	X	X	-	X	-	X	X	-
Cycling-Thermal	X	X	-	X	-	X	X	-
Hydrostatic Burst	X	X	X	X	X	X	X	X
Gunfire	X	X	X	X	X	X	X	-
Bonfire	X	X	X	X	X	X	X	-
* Drop Test	X	X	X	X	X	X	X	X
Stress Analysis	X	X	X	X	-	X	-	X

X = Applies

- = Does not apply

CFFC-12 MANUFACTURING, QUALITY ASSURANCE, AND LOT QUALIFICATION TESTS :

(a) **Manufacturing:**

(i) The manufacturer is responsible for total compliance with this standard and as prescribed in the DOT exemption.

\*\*\*\*

(ii) All materials, manufacturing equipment types, fabrication processes, and quality control procedures for production cylinders shall conform in all aspects with those used in the manufacture of the cylinders used in design qualification tests.

(iii) The manufacturer shall retain production data, including lot qualification test results for each lot of 200 cylinders successively produced, and retain the records for the cylinder's approved service life.

(b) **Quality Control Procedures:**

(i) The manufacturer shall establish and maintain for each design type a documented quality assurance system described fully with control features in a quality manual.

(ii) The manufacturer shall establish procedures for compliance with all control features to the satisfaction of the independent inspector.

(c) **Lot definition:**

(i) Completed cylinders: A "lot" means a group of cylinders successively produced as completed cylinders.

(ii) Unless approved in writing by AAHMS, in no case shall the lot size exceed 200 cylinders excluding the cylinders used for lot qualification tests.

(d) **Lot qualification tests:** For each lot of completed cylinders, qualification tests as prescribed herein shall be performed with satisfactory results.

(i) **Burst test:** One cylinder (randomly selected) from each lot of completed cylinders must be hydrostatically tested in accordance with the following:

(A) **Procedure:** Cylinder must be tested in accordance with CFFC-10(b)(i) of this

standard. A cylinder used in the cycling test may be used for the burst test.

(B) **Acceptable test results:** The measured burst pressure may not be less than the minimum required burst pressure. Failure must initiate in the cylinder sidewall.

(ii) **Ambient temperature cycling**

**pressurization tests:** One cylinder (randomly selected) from each lot of completed cylinders must be subjected to cyclic pressurization testing in accordance with the following:

(A) **Procedure:** The cylinder shall be cycled to service pressure in accordance with CFFC-10(d)(i) of this standard. Adequate recording instrumentation must be provided if the test is expected to run unattended for any period of time exceeding two hours.

(B) **Acceptable test results:** Test results must be in accordance with CFFC-10(d)(ii) of this standard.

(e) **Lot acceptance criteria:**

(i) All cylinders in a lot that did not meet the required lot qualification test results must be rejected.

(ii) However, when a cylinder fails a test, five additional cylinders selected randomly may be subjected to the same test. If all five cylinders pass, the lot may be accepted. If one or more of the cylinders fails, the lot must be rejected.

CFFC-13 **PRODUCTION TESTS:** The following nondestructive tests and inspections shall be performed on all completed cylinders in each lot.

(a) **Hydrostatic test.** Each cylinder must be hydrostatically pressurized to test pressure after the cylinder has been autofrettaged. The test pressure must be maintained for a minimum of 60 seconds and as much longer as may be necessary to ensure stable volumetric expansion. The elastic and total volumetric expansions must be determined. Cylinders that show evidence of leakage or distortion must be rejected.

(i) The hydrostatic test must be by the water jacket method. The system must be calibrated



and operated so as to obtain accurate data. The pressure reading must be accurate within one percent in the range of 80 percent to 120 percent of the test pressure, and the volumetric expansion measurement must be accurate to within one percent of the total expansion established when in system calibration, or 0.1 cubic centimeter. Records must be maintained as evidence of the equipment calibration.

\*(ii) The hydrostatic test system must be calibrated at the beginning of each day prior to testing using a Calibrated Cylinder following procedures specified in CGA pamphlet C-1 "Methods of Hydrostatic Testing of Compressed Gas Cylinders."

(b) **Visual inspection and marking:** All cylinders in each lot must be subjected to a thorough visual inspection for quality and for conformance with the marking requirements.

CFFC-14 **MARKING:**

(a) Each cylinder that is made in conformance with this standard and the applicable DOT exemption must be permanently marked (other than stamping) in the composite overwrap on the sidewall. The marking must be easily visible and must be protected from external damage due to the environment and handling.

(b) The details of the marking must conform to the requirements of this standard and the DOT exemption under which the cylinders are manufactured. The marking must contain the following:

(i) DOT Exemption number (DOT E-XXXXX) followed by service pressure expressed in pounds per square inch gauge (psig).

(ii) A serial number and the manufacturer's identification number or a symbol as obtained from the Associate Administrator for Hazardous Materials safety, located just below or immediately following the DOT marking above.

(iii) The DOT inspector's official mark must be placed near the serial number. The marking must contain date (month and year) of the initial hydrostatic test for that cylinder.

\* (iv) Rejection elastic expansion (REE) marking in cubic centimeters. The REE for each design type cylinder is obtained as follows:

1. Perform hydrostatic testing on a lot of cylinders and record elastic expansion (EE) of each cylinder.
2. Find the mean value of the EE for all cylinders tested in item 1.
3. Mark each cylinder with REE which is less than or equal to 10% above the mean value obtained in item 2.

(v) The size of the letters and numbers used must be at least 0.64cm (1/4 inch) high if space permits.

(vi) The following are the authorized formats for marking:

DOT- E xxxxx-PPPP  
1234-MMI (or symbol)  
II-MM/YY REE

and, DOT-E xxxxx-PPPP-1234-MMI-MM/YY REE NNN

(vii) Additional markings are permitted in the composite, provided the additional markings do not obscure the required markings and are not detrimental to the integrity of the cylinder.

(vii) Provisions for marking of the required retest dates and retester information must be made near the cylinder markings.

CFFC-15 **INSPECTOR'S REPORTS:**

(a) The inspector must prepare a report that is clear, legible and in accordance with the following form:

**REPORT OF MANUFACTURE OF CARBON FIBER REINFORCED PLASTIC  
FULL COMPOSITE CYLINDERS (CFFC)**

(Place) \_\_\_\_\_  
 (Date) \_\_\_\_\_  
 (Exemption number) \_\_\_\_\_  
 Manufactured for \_\_\_\_\_  
 Company.  
 Located at \_\_\_\_\_  
 Manufactured by \_\_\_\_\_  
 Company.  
 Located at \_\_\_\_\_  
 Consigned to \_\_\_\_\_  
 Company.  
 Located at \_\_\_\_\_  
 \_\_\_Quantity \_\_\_ Size \_\_\_ inches outside diameter by \_\_\_  
 \_\_\_ inches long

Marking placed on the \_\_\_\_\_ of the cylinder is:

DOT-E \_\_\_\_\_  
 Serial numbers \_\_\_\_\_ to \_\_\_\_\_  
 inclusive.  
 Identifying symbol (Registered) \_\_\_\_\_  
 Inspector's mark (Registered) \_\_\_\_\_  
 Test date(s) \_\_\_\_\_  
 Other marks (if any) \_\_\_\_\_

Each composite cylinder was made by completely over wrapping a seamless aluminum liner with resin impregnated filament reinforcement. Composite overwrap was made by winding resin impregnated \_\_\_\_\_ continuous filament over this liner in both longitudinal and circumferential directions, followed by curing the resin at controlled temperature.

The aluminum liner was identified by heat numbers and verified as to chemical analysis, record thereof is attached hereto. Liners fabricated from the aluminum were solution heat treated and artificially aged to T-6 temper. Physical tests were made in the presence of the inspector and report of test results is attached hereto.

Each liner was inspected before and after closing in the ends. All that were inspected were found to be free from seams, cracks, laminations and other defects which might prove injurious to the strength of the cylinder.

Liner walls were measured and the minimum thickness noted was at least equal to the minimum design thickness. The outside diameter was found by a close approximation to be \_\_\_\_\_ inches.

Filament and resin were certified by the manufacturers, and identified by package number. Filament was verified as to strand strength. Composite was verified as to shear strength. After wrapping, composite was cured per manufacturers's specification.

Prescribed autofrettage and hydrostatic tests were made in the presence of the inspector. All cylinders accepted conform with the specification requirements. Results of autofrettage and hydrostatic tests are attached hereto.

Tensile stress on the aluminum liner in the hoop direction is calculated to be \_\_\_\_\_psi at service pressure. Carbon fiber stress is calculated to be \_\_\_\_\_psi in the hoop direction and \_\_\_\_\_ psi in the longitudinal direction at service pressure.

I hereby certify that all of these cylinders proved satisfactory in every way and conform with the requirements of DOT-E \_\_\_\_\_ ; except as follows:

Exceptions taken to any reporting or testing requirements of this exemption are: \_\_\_\_\_

\_\_\_\_\_  
\_\_\_\_\_

\_\_\_\_\_  
(Signed) \_\_\_\_\_  
(Inspector)

## DOT-CFFC BASIC REQUIREMENTS (FOURTH REVISION)

PAGE 24

## RECORD OF CHEMICAL ANALYSES OF MATERIAL FOR LINER

(Place) \_\_\_\_\_ (Date) \_\_\_\_\_  
 (Exemption number) \_\_\_\_\_  
 Serial numbers \_\_\_\_\_ to \_\_\_\_\_ inclusive.  
 Size \_\_\_\_\_ inches outside diameter by \_\_\_\_\_ inches long.  
 Made by \_\_\_\_\_ Company.  
 For \_\_\_\_\_ Company.  
 Material description \_\_\_\_\_

NOTE: Any omission of analyses by heats, if authorized, must be accounted for by notation herein reading "The prescribed certificate of the manufacturer of material has been secured, found satisfactory, and placed on file." or by attaching a copy of the certificate.

Alloy Designation (Per Aluminum Assoc.)	Cylinders Represented (Serial Nos.)	Chemical Analysis												
		Si	Fe	Cu	Mn	Mg	Cr	Pb	Bi	Zn	Ti	Others		Al
												Each	Total	
														Remainder

Material was manufactured and mill analyses made by \_\_\_\_\_. Originals of the certified mill analyses reports are in files of the material manufacturer.

(Signed) \_\_\_\_\_  
 (Inspector)

## RECORD OF PHYSICAL TESTS OF MATERIAL FOR LINERS .

(Place) \_\_\_\_\_ (Date) \_\_\_\_\_  
 (Exemption Number) \_\_\_\_\_  
 Serial numbers \_\_\_\_\_ to \_\_\_\_\_ inclusive.  
 Size \_\_\_\_\_ inches outside diameter by \_\_\_\_\_ inches long.  
 Made by \_\_\_\_\_ Company

## DOT-CFFC BASIC REQUIREMENTS (FOURTH REVISION)

PAGE 25

For \_\_\_\_\_ Company

Test specimen description \_\_\_\_\_

Lot Code	Cylinders Represented by test (Serial Numbers)	Yield strength at 0.2 percent offset (psi)	Tensile strength (psi)	Elongation (percent)

(Signed) \_\_\_\_\_  
(Inspector)

## REPORT OF COMPOSITE ANALYSES

(Place) \_\_\_\_\_ (Date) \_\_\_\_\_  
 (Exemption number) \_\_\_\_\_  
 Materials \_\_\_\_\_  
 Manufactured by \_\_\_\_\_ Company  
 For \_\_\_\_\_ Company  
 Numbered \_\_\_\_\_  
 Filament specification and designation \_\_\_\_\_  
 Manufactured by \_\_\_\_\_ Company

\*\*\*\*

## Filament materials

Manufacturing Package Number	Tensile Strength

RESIN SYSTEM COMPONENTS  
MANUFACTURING BATCH NUMBERS

Resin			Curing Agent		Accelerator	
Batch Number	Type	Interlaminar Shear Strength	Batch Number	Type	Batch Number	Type

Signed \_\_\_\_\_  
 (Inspector)

## REPORT OF HYDROSTATIC TEST FOR CFFC TYPE CYLINDERS

(Place) \_\_\_\_\_ (Date) \_\_\_\_\_  
 (Exemption number) \_\_\_\_\_  
 Manufactured by: \_\_\_\_\_  
 Located at: \_\_\_\_\_





LOT CYCLING AND BURST TESTS				
Type of Test	Serial Number of Cylinder	Number of Pressurization		Burst Pressure (psig)
		To Service Pressure	To Test Pressure	
Cycling				
Virgin Burst				

Signed: \_\_\_\_\_  
(Inspector)

CFFC-16 **RETENTION OF REPORTS:** The inspector's report (CFFC-15) must be retained for the approved service life of the cylinder by the maker and the inspector.

**DOT FRP - 1 STANDARD**

DATE: Original; July 1, 1981

Revision 1; March 15, 1982

Revision 2; February 15, 1987

**BASIC REQUIREMENTS FOR FIBER REINFORCED PLASTIC (FRP)  
TYPE 3FC COMPOSITE CYLINDERS**

§ 178.AA **Fiber reinforced plastic (FRP) full (wrapped) composite (FC) cylinders made of definitely prescribed materials.**

§ 178.AA-1 **General.**

Each cylinder must conform with these basic requirements and the specific requirements of the applicable exemption.

§ 178.AA-2 **Type, size and service pressure.**

Type 3FC cylinder consisting of resin impregnated continuous filament windings in both longitudinal and circumferential directions only over a seamless aluminum liner; not over 200 pounds water capacity; and service pressure at least 900 PSI but not greater than 5000 PSI.

§ 178.AA-3 **Inspection by whom and where.**

Inspections and verifications must be performed by an independent inspection agency approved in writing by the Director for the Office of Hazardous Materials Transportation (OHMT), in accordance with 49 CFR 173.300a. Chemical analyses and tests must be made in the United States unless otherwise approved in writing by the Director for OHMT in accordance with 49 CFR 173.300b.

§ 178.AA-4 **Duties of the inspector.**

(a) Determine that all materials conform with the provisions of this standard before releasing them for cylinder manufacture.

(b) Verify chemical analysis of each heat of liner material by analysis or by obtaining producers certified analysis. A certification from the manufacturer indicating conformance with this requirement is acceptable when verified by check analysis on one sample taken from one cylinder liner

2

out of each inspection lot of 200 cylinders or less. Verify conformance of filament and resin system components with the requirements specified in § 178.AA-5.

(c) Prior to the initial shipment of any specific composite cylinder design, verify that the design qualification tests prescribed in § 178.AA-18 have been performed with acceptable results.

(d) Verify conformance of completed cylinder with all requirements including marking, condition of inside, heat treatment, and threads. Report minimum thickness of liner wall noted.

(e) Verify winding process to assure that composite material is uniform, of required thickness and pattern, and in accordance with the composite structure present in cylinders subjected to the design qualification tests.

(f) Witness all tests and pressurization, obtain copies of all test results and certifications; report volumetric capacity, permanent expansion and completed composite cylinder weight.

(g) Furnish completed inspector's report (§ 178.AA-16) to the maker of the cylinder and upon request, to the purchaser. (See § 178.AA-17).

§ 178.AA-5 **Authorized material and identification of material.**

(a) Aluminum liner must be 6351 or 6061 alloy and T6 temper.

(b) Filament material must be commercial Type-S or commercial Type-E fiberglass. Filaments must be tested in accordance with ASTM D-2343-79 and have minimum strand strength as follows:

(1) Type-S Glass ---- 400,000 PSI.

(2) Type-E Glass ---- 200,000 PSI.

(c) Resin system must be epoxy or modified epoxy type. Resin system must be tested on sample coupons representative of the composite over-wrap in accordance with ASTM D-2344-67 for water boil shear test, and have a minimum shear strength of 5,000 PSI.

(d) Materials must be identified by a suitable method during

manufacture.

(e) Materials must be of uniform quality. Materials with injurious defects are not authorized.

§ 178.AA-6 **Manufacture.**

(a) **Liner.** Aluminum liner must have dirt and scale removed as necessary to afford proper inspection; no defect that is likely to weaken the finished liner appreciably is authorized; reasonably smooth and uniform surface finish is required. No interior folding in the neck area is permitted; smooth gathering of the material in the neck in which there are no sharp rooted folds is acceptable. If not originally free from such defect, the liner surface may be machined or otherwise treated to eliminate these defects provided the required minimum wall thickness is maintained. Liner end contour must be concave to pressure.

(b) **Composite cylinder.** The composite cylinder must be fabricated from an aluminum liner fully overwrapped with resin impregnated continuous filament windings. Winding pattern must be "helical" or "in plane and hoop" wrap, applied under controlled tension to develop the design composite thickness. After winding is complete, the composite must be cured by a controlled temperature profile, and auto-fretted by pressurizing to not less than 105 and not greater than 115 percent of the prescribed minimum test pressure. No defect that is likely to weaken the finished cylinder appreciably is acceptable.

(c) **Welding or brazing.** Welding or brazing for any purpose whatsoever is prohibited.

(d) **Lot size.**

(1) **Liner lot size.** A "liner lot" means a group of liners successively produced having the same: size and configuration; specified material of construction; process of manufacture and heat treatment; equipment of manufacture and heat treatment; and conditions of time, temperature and atmosphere during heat treatment.

4

(2) **Composite cylinder lot size.** A "composite cylinder lot" means a group of cylinders successively produced from qualified liners, having the same size and configuration, the same specified materials of construction, the same process of manufacture to the same cylinder specification and auto-frettagged under the same conditions of temperature, time and pressure.

(3) In no case may the lot size exceed 200 units; however, any unit processed for use in the required destructive tests need not be counted as one of the 200, but must have been processed with the lot.

(e) **Design qualification tests.** Prior to initial shipment of any specific cylinder design, qualification tests as prescribed in § 178.AA-18 must have been performed with satisfactory results.

§ 178.AA-7 **Wall thickness.**

(a) Minimum thickness of the liner must be such that after auto-frettagage, the compressive stress in the sidewall of the liner at zero pressure will not exceed 95 percent of the minimum yield strength of the aluminum as determined in § 178.AA-12(a) or 95 percent of the minimum design yield strength shown in § 178.AA-18(h). The maximum tensile stress of the liner at operating pressure must not exceed 60 percent of the yield strength.

(b) The maximum filament stress at service pressure must not exceed 30 percent of the filament stress at the virgin burst pressure of the lot test cylinder.

(c) The end designs must incorporate added materials to assure the stresses in these areas are less than the stresses found in the cylindrical portion.

(d) Stresses shall be computed from Computer Code NASA CF-72124 "Computer Program for the Analysis of Filament-Wound Reinforced Metal Shell Pressure Vessels" May 1966, or other suitable analysis techniques.

§ 178.AA-8 **Openings.**

(a) Openings are permitted on the heads only. Center line of openings must coincide with the longitudinal axis of the cylinder.

(b) Threads are required. Threads must be clean cut, even, without

checks and to gauge.

(c) Tapered threads are not permitted.

(d) Straight threads conforming with National Gas Straight (NGS) thread standard are authorized. These threads must conform to the requirements of Federal Standard (FED-STD)-H28 (1978). Other straight threads having at least 6 engaged threads are authorized provided that the calculated shear strength is at least 10 times the test pressure of the cylinder.

**§ 178.AA-9 Thermal treatment.**

(a) The aluminum liner must be solution heat treated and aged to the T-6 temper after all forming operations and prior to pressurizing and overwrapping.

(b) The resin must be cured at the temperature specified and by the process set forth in the cylinder manufacturer's specification and noted in the Inspector's report. Curing temperature and process must correspond with that applied to the cylinders subjected to the qualification tests. The curing temperature must not exceed 350 ° F.

**§ 178.AA-10 Pressure relief devices and protection for valves, relief devices, and other connections.**

Pressure relief devices and protection for valves and other connections must conform with 49 CFR 173.34(d) and 173.301(g), except that the adequacy of the pressure relief devices for each design may be verified in accordance with § 178.AA-18(g).

**§ 178.AA-11 Nondestructive tests.**

(a) **Hydrostatic test.**

(1) By water-jacket, operated so as to obtain accurate data. Pressure gauge must permit reading to accuracy of 1 percent in the range of 80 percent to 120 percent of test pressure. Expansion gauge must permit reading of total expansion to an accuracy of either 1 percent or 0.1 cubic centimeter.

(2) The accuracy of the test equipment must be maintained by

periodic recalibration. Records must be maintained to verify that the test equipment is calibrated on a regular basis. A calibration cylinder capable of verifying the equipment accuracy for the material, size and test pressure of the cylinders to be tested must be used for checking the equipment at the beginning of each day.

(3) Pressure must be maintained for 30 seconds and sufficiently longer to insure complete expansion. Any internal pressure applied after auto-frettage and previous to the official test must not exceed 90 percent of the test pressure. If, due to failure of test apparatus, the test pressure can not be maintained, the test may be repeated at a pressure increased by 10 percent or 100 PSI, whichever is lower. Not more than 2 such repeated tests are permitted.

(4) Each cylinder must be tested to at least  $5/3$  times service pressure. In no case may the test pressure exceed the auto-frettage pressure.

#### § 178.AA-12 **Destructive tests.**

(a) **Physical tests.** To determine yield strength, tensile strength and elongation of the aluminum liner material. Applies to aluminum liner only.

(1) Required on 2 specimens cut from one liner taken at random out of each lot of 200 liners or less.

(2) Specimens must be: gauge length of 2 inches with width not over 1-1/2 inches; or gauge length of 4 times the specimen diameter (4D bar), provided that a specimen with gauge length at least 24 times thickness with width not over 6 times thickness is authorized when liner wall is not over 3/16 inch thick. The specimen, exclusive of grip ends, must not be flattened. Grip ends may be flattened to within one inch of each end of the reduced section. When size of liner does not permit securing straight specimens, the specimens may be taken in any location or direction and may be straightened or flattened cold and by pressure only, not by blows. When such specimens are used, the inspector's report must show that the specimens were so taken and prepared. Heating of specimens for any purpose is not authorized.

(3) The yield strength in tension shall be the stress corresponding to a permanent strain of 0.2 percent of the gauge length.

(i) The yield strength shall be determined by either the

"offset" method or the "extension under load" method as prescribed by ASTM Standard E8-78.

(ii) In using the "extension under load" method, the total strain or "extension under load" corresponding to the stress at which the 0.2 percent permanent strain occurs may be determined with sufficient accuracy by calculating the elastic extension of the gauge length under appropriate load and adding thereto 0.2 percent of the gauge length. Elastic extension calculations shall be based on an elastic modulus of 10,000,000. In the event of controversy, the entire stress-strain diagram shall be plotted and the yield strength determined from the 0.2 percent offset.

(iii) For the purpose of strain measurement, the initial strain shall be set while the specimen is under a stress of 6,000 pounds per square inch, the strain indicator reading being set at the calculated corresponding strain.

(iv) Cross-head speed of the testing machine shall not exceed 1/8 inch per minute during yield strength determination.

(b) **Cycling test.** One cylinder taken at random out of each lot of 200 cylinders must be subjected to cyclic pressurization test by hydrostatically pressurizing the cylinder between approximately zero PSIG and the designated pressure at a rate not to exceed 4 cycles per minute. Adequate recording instrumentation must be provided if the equipment is to be left unattended for periods of time. All cylinders used in the cycle test must be destroyed.

(c) **Burst test.** One cylinder taken at random out of each lot of cylinders shall be hydrostatically tested to destruction by pressurizing at a uniform rate up to minimum prescribed burst pressure, holding the pressure constant at minimum burst pressure for 60 seconds; and increasing the pressure to failure. The rate of pressurization must not exceed 200 PSI per second. The cylinder cycle tested in paragraph (b)(1) above may be used for this burst test.



§ 178.AA-13 **Acceptable results of tests.**

(a) **Hydrostatic test.**

(1) The permanent volumetric expansion of the cylinder must not exceed 5 percent of the total volumetric expansion at test pressure.

(2) All cylinders failing to pass the hydrostatic test must be rejected.

(b) **Physical test.** Applies to aluminum liner only.

(1) Elongation must be at least 14 percent; except that an elongation of 10 percent is acceptable when the authorized specimen size is 24t x 6t.

(2) When the test results fail to meet requirements, the lot must be rejected.

(3) A retest of a rejected lot is authorized if an improper test was made due to the presence of a defect in the specimen or if the equipment or procedure was faulty. The retest must be performed on specimens taken from the same cylinder liner.

(c) **Cycling test.**

(1) Each test cylinder must withstand at least 10,000 pressurization between approximately zero and service pressure followed by at least 30 pressurizations between zero and test pressure, without evidence of distortion or failure.

(2) When the test cylinder fails to withstand the cycle test, the lot represented must be rejected.

(d) **Burst test.**

(1) Burst pressure shall be at least 3 times the service pressure and in no case less than the value necessary to meet the stress criteria of § 178.AA-7(b). Failure must initiate in the cylinder sidewall. Cylinders with marked service pressure not exceeding 2,200 PSI must remain in one piece. Actual burst pressure must be recorded.

(2) When the test cylinder fails to withstand pressure up to the minimum prescribed burst pressure, the lot represented must be rejected.

§ 178. AA-14 **Rejected liners and cylinders.**

(a) **Physical test.** Reheat treatment of aluminum liners that failed the physical test is authorized. Subsequent thereto, acceptable liners must pass all prescribed tests.

(b) **Hydrostatic test.** Cylinders rejected by the hydrostatic test must not be placed in service.

(c) **Cycle test.** Cylinders of lots rejected by the cycle test must not be placed in service.

(d) **Burst test.** Cylinders of lots rejected by the burst test must not be placed in service.

§ 178. AA-15 **Marking.**

(a) Each cylinder must be permanently marked (other than stamping in the filament wrap) in the epoxy coating on the side near the end of the cylinder containing the valve outlet.

(b) Required markings are as follows:

(1) DOT-E \*\*\*\*-YYYY (where \*\*\*\*=Exemption number, and YYYY = service pressure in PSIG).

(2) A serial number and an identifying symbol (letters); location of serial number to be just below or immediately following the DOT mark; location of symbol to be just below or immediately following the number. The symbol and number must be those of the maker. The symbol must be registered with the Director for OHMT; duplications not authorized.

(3) The Inspector's official mark must be placed near the serial number.

(4) Date of test (month and year) so placed that dates of subsequent tests can be easily added.

10

(5) Examples of cylinder marking:

DOT-E \*\*\*\*-2000

1234-XY

AB

3-81

or;

DOT-E \*\*\*\*-2000-1234-XY-AB-3-81

(c) Size of marks must be at least 1/4 inch high if space permits.

(d) Additional markings are permitted (in the epoxy coating).

§ 178. AA-16 **Inspector's report.**

(a) The inspector must prepare a report that is clear, legible and in accordance with the following form:

**REPORT OF MANUFACTURE OF FIBER REINFORCED PLASTIC (FRP) TYPE 3FC  
FULL COMPOSITE (FC) ALUMINUM LINED COMPRESSED GAS CYLINDER.**

(Place) \_\_\_\_\_

(Date) \_\_\_\_\_

(Exemption number) \_\_\_\_\_

Manufactured for \_\_\_\_\_ Company.  
 Located at \_\_\_\_\_  
 Manufactured by \_\_\_\_\_ Company.  
 Located at \_\_\_\_\_  
 Consigned to \_\_\_\_\_ Company.  
 Located at \_\_\_\_\_  
 Quantity \_\_\_\_\_ Size \_\_\_\_\_ inches outside diameter by \_\_\_\_\_ inches long

Marks placed on the \_\_\_\_\_ of the cylinder are:

DOT-E \_\_\_\_\_  
 Serial numbers \_\_\_\_\_ to \_\_\_\_\_ inclusive.  
 Identifying symbol (Registered) \_\_\_\_\_  
 Inspector's mark (Registered) \_\_\_\_\_  
 Test date(s) \_\_\_\_\_  
 Other marks (if any) \_\_\_\_\_

Each composite cylinder was made by completely overwrapping a seamless aluminum liner with resin impregnated filament reinforcement. Composite overwrap was made by winding resin impregnated \_\_\_\_\_ continuous filament over this liner in both longitudinal and circumferential directions, followed by curing the resin at controlled temperature.

The aluminum was identified by heat numbers and verified as to chemical analysis, record thereof is attached hereto. Liners fabricated from the aluminum were solution heat treated and artificially aged to T-6 temper. Physical tests were made in the presence of the inspector and report of test results is attached hereto.

Each liner was inspected before and after closing in the ends. All that were inspected were found to be free from seams, cracks, lamination and other defects which might prove injurious to the strength of the cylinder.

Liner walls were measured and the minimum thickness noted was at least equal to the minimum design thickness. The outside diameter was found by a close approximation to be \_\_\_\_\_ inches.

Filament and resin were certified by the manufacturers, and identified by package number. Filament was verified as to strand strength. Composite was verified as to shear strength. After wrapping, composite was cured per manufacturers' specification.

12

Prescribed auto-frettage and hydrostatic tests were made in the presence of the inspector. All cylinders accepted conform with the specification requirements. Results of auto-frettage and hydrostatic tests are attached hereto.

Tensile stress on the aluminum liner is calculated to be \_\_\_ PSI at service pressure. Filament stress is calculated to be \_\_\_ PSI in the hoop direction and \_\_\_ PSI in the longitudinal direction at service pressure.

I hereby certify that all of these cylinders proved satisfactory in every way and conform with the requirements of DOT-E \_\_\_\_ ; except as follows:

Exceptions taken to any reporting or testing requirements of this exemption are: \_\_\_\_\_

\_\_\_\_\_.

(Signed) \_\_\_\_\_  
(Inspector)

#### RECORD OF CHEMICAL ANALYSES OF MATERIAL FOR LINER

(Place) \_\_\_\_\_

(Date) \_\_\_\_\_

(Exemption number) \_\_\_\_\_

Serial numbers \_\_\_\_\_ to \_\_\_\_\_ inclusive.

Size \_\_\_\_\_ inches outside diameter by \_\_\_\_\_ inches long.

Made by \_\_\_\_\_ Company.

For \_\_\_\_\_ Company.

Material description \_\_\_\_\_

\_\_\_\_\_.

NOTE: Any omission of analyses by heats, if authorized, must be accounted for by notation herein reading "The prescribed certificate of the manufacturer of material has been secured, found satisfactory, and placed on file." or by attaching a copy of the certificate.

Alloy      Cylinders

Designation Represented (Serial Numbers)	Chemical Analyses										
	Si	Fe	Cu	Mn	Mg	Cr	Zn	Ti	Others		Al
									Ea.	Total	

Material was manufactured and mill analyses made by \_\_\_\_\_.  
Originals of the certified mill analyses reports are in files of the material manufacturer.

(Signed) \_\_\_\_\_  
(Inspector)

#### RECORD OF PHYSICAL TESTS OF MATERIAL FOR LINERS.

(Place) \_\_\_\_\_  
(Date) \_\_\_\_\_  
(Exemption Number) \_\_\_\_\_  
Serial numbers \_\_\_\_\_ to \_\_\_\_\_ inclusive.  
Size \_\_\_\_\_ inches outside diameter by \_\_\_\_\_ inches long.  
Made by \_\_\_\_\_ Company  
For \_\_\_\_\_ Company  
Test specimen description \_\_\_\_\_.

Lot Code	Cylinders Represented by Test. (Serial Nos)	Yield Strength at 0.2 percent Offset (pounds per square inch)	Tensile Strength (pounds per square inch)	Elongation (percent)

(Signed) \_\_\_\_\_  
(Inspector)

#### REPORT OF COMPOSITE ANALYSES

(Place) \_\_\_\_\_  
(Date) \_\_\_\_\_  
(Exemption number) \_\_\_\_\_  
Materials \_\_\_\_\_  
Manufactured by \_\_\_\_\_ Company  
For \_\_\_\_\_ Company  
Numbered \_\_\_\_\_  
Filament specification and designation \_\_\_\_\_

14

Manufactured by \_\_\_\_\_ Company

Manufacturing package number	Tensile strength	Inter-laminar shear strength

**RESIN SYSTEM COMPONENTS  
MANUFACTURING BATCH NUMBERS**

Resin		Curing agent		Accelerator	
Batch number	Type	Batch number	Type	Batch number	Type

Signed \_\_\_\_\_  
Inspector

**REPORT OF HYDROSTATIC TEST FOR FRP TYPE 3FC CYLINDERS**

(Place) \_\_\_\_\_

(Date) \_\_\_\_\_

(Exemption number) \_\_\_\_\_

Manufactured by: \_\_\_\_\_

Located at: \_\_\_\_\_

Manufactured for: \_\_\_\_\_

Located at: \_\_\_\_\_

Serial numbers: \_\_\_\_\_ to \_\_\_\_\_ inclusive.

Symbol \_\_\_\_\_

Minimum prescribed test pressure \_\_\_\_\_ psi g.

<u>Weight - pounds</u> <u>(without valve)</u>	Hydrostatic test
--	------------------

Perma-

Serial number	Compo- Liner site	Volume Total cu.in	Auto- fretage pressure psig	Total expan- sion cu.in	ment expan- sion cu.in	Ratio of PE to TE percent	Actual test sure psig

### LOT CYCLING AND BURST TESTS

Type of test	Serial Number of cylinder	Number of pressurizations to service pressure	Number of pressurizations to test pressure	Burst pressure (psig)
Cycling				
Virgin Burst				

#### § 178.AA-17 Retention of inspector's report.

The inspector's report (§ 178.AA-16) must be retained for 15 years from the original test date on the cylinder by the maker and the inspector.

#### § 178.AA-18 Design qualification tests.

(a) **General** - Except as authorized in § 178.AA-10(a), the



qualification tests as prescribed in this paragraph shall have been performed on representative cylinders of each specific design prior to any initial shipment. All cylinders used for design qualification tests must be fabricated on the same equipment and subjected to the same processes as is used to produce cylinders intended for charging and shipment. All tests must be witnessed by an independent inspector. Test reports must be kept on file by the cylinder maker and made available to the independent inspector and the OHMT upon request.

(b) **Design changes.** For purposes of this standard, a design change is: (1) any change in material; (2) a 10 percent or greater change in diameter or service pressure; or (3) a 30 percent or greater change in water capacity.

(c) **Test requirements.** Each cylinder design or any design change to an approved cylinder design must be qualified by subjecting representative cylinders to the tests prescribed in the following table:

Type of test	ORIGINAL DESIGN	DESIGN CHANGE				
		Material	Diameter or Service pressure		Water capacity	
		Any change	10 to 20 percent change	Greater than 20 percent change	30 to 50 percent change	Greater than 50 percent change
Cycling-Ambient	X	X	X	X	X	X
Cycling-Environmental	X	X	-	X	-	X
Cycling-Thermal	X	X	-	X	-	X
Hydraulic burst	X	X	X	X	X	X
Gunfire	X	X	X	X	X	X
Bonfire	X	X	X	X	X	X

(d) **Pressure cycling tests.** All cycling tests shall be performed by hydrostatically pressurizing the cylinder between approximately zero and designated pressure at a rate not in excess of 4 cycles per minute. All cylinders used in cycle tests must be destroyed. Adequate recording

instrumentation must be provided if equipment is to be left unattended for periods of time.

(1) **Cycling test at ambient temperature.** One representative cylinder shall be cycle tested at ambient temperature without showing evidence of distortion, deterioration or failure, as follows: pressurize from approximately zero to service pressure for 10,000 cycles; then pressurize from approximately zero to test pressure for at least 30 cycles. After successfully passing this test the cylinder must be pressurized to burst in accordance with paragraph (e)(1) of this section and the burst pressure recorded.

(2) **Environmental cycling test.** One representative cylinder free of any protective coating shall be cycle tested without showing evidence of distortion, deterioration or failure as follows. Any cylinder subjected to this cycling test must be destroyed.

(i) Condition the cylinder for 48 hours at zero pressure, 140 °F. or higher and 95 percent or greater relative humidity.

(ii) Pressurize from zero to service pressure for 5,000 cycles at 140 °F. or higher and 95 percent or greater relative humidity.

(iii) Stabilize at zero pressure and ambient conditions.

(iv) Then pressurize from zero to service pressure for 5,000 cycles at -60 °F. or lower.

(v) Stabilize at zero pressure and ambient temperature conditions.

(vi) Then pressurize from zero to test pressure for 30 cycles at ambient temperature.

(3) **Thermal cycling test.** One representative cylinder shall be tested without showing evidence of distortion, deterioration or failure as follows. After successfully passing this test, the cylinder must be pressurized to burst in accordance with paragraph (e)(1) of this section and burst pressure recorded.

(i) Cycle test at ambient temperature by performing 10,000

pressurizations from approximately zero to service pressure and at least 30 pressurizations from zero to test pressure.

(ii) Then hydrostatically pressurize to service pressure; and submerge the pressurized cylinder in 200 °F. fluid, soak for 10 minutes; transfer and submerge in -60 °F. fluid and soak for 10 minutes. Subject cylinder to 20 such cycles restricting the transfer time to at least one minute but not more than 3 minutes. The pressure in the cylinder may be controlled so that it does not exceed test pressure nor less than marked service pressure.

(e) **Hydraulic burst test.**

(1) One representative cylinder shall be hydrostatically pressurized to failure as follows: pressure shall be increased at a uniform rate up to minimum prescribed burst pressure; this pressure to be held for at least 60 seconds; then pressure will be further increased to failure. The pressurization rate throughout the test must not exceed 200 psi per second.

(2) Burst pressure must be at least 3 times the marked service pressure, and in no case less than the value necessary to meet the stress criteria of § 178.AA-7(b). Failure must initiate in the sidewall. Cylinders with marked service pressure not exceeding 2200 psi must remain in one piece. Actual burst pressure must be recorded.

(f) **Gunfire Test.** One representative cylinder charged with air or nitrogen to service pressure shall be impacted by a 0.30 caliber armor-piercing projectile having a velocity of approximately 2800 feet per second. Cylinder shall be positioned so that the projectile impact point is in the cylinder sidewall having hoop winding, at approximately 45 degree angle and aimed to exit at the cylinder sidewall. Distance from firing location to test cylinder must not exceed 50 yards. Tested cylinder shall reveal no evidence of a fragmentation failure. Approximate size of entrance and exit openings must be recorded.

(g) **Bonfire test.** Test cylinders must be fitted with pressure relief devices in accordance with § 178.AA-10 and charged with the intended lading to the prescribed filling pressure or density. Charging with nitrogen or air to service pressure is authorized only if cylinders are to be charged only with non-liquefied gases. Fire for the test shall be generated by kerosine-soaked wood, gasoline or JP-4 fuel. The lowest part of the cylinder

shall be approximately 4 inches above the base of the fire when wood fire is used or shall be approximately 4 inches above the liquid surface if gasoline or JP-4 fuel is used. Test cylinder shall be exposed to fire until completely vented. Time-pressure readings must be recorded at 30 second intervals from start of fire until venting is completed. Test results are not acceptable if contents vent from any location other than through a pressure relief device. After successfully passing the fire test, each cylinder must be pressurized to burst and burst pressure recorded. Tests must be performed as follows:

(1) **Vertical test.** Place test cylinder in its upright position and subject to total fire engulfment but in no case shall the flame be allowed to impinge directly on any relief device. Shielding of pressure relief devices with a metal plate may be used but is not a requirement. For cylinders equipped with relief devices on both ends, the bottom relief devices must be shielded from any flame impingement.

(2) **Horizontal tests.** Place test cylinder in its upright position and subject the entire length to flame impingement except that the flame must not be allowed to impinge directly on any relief device. Shielding of the pressure relief devices with a metal plate may be used but is not a requirement.

(3) **Cylinders for liquefied gas service.** At least one representative cylinder must be subjected to the horizontal test and two to the vertical test.

(4) **Cylinders for non-liquefied gas service only.** At least 2 cylinders must be subjected to the vertical test. Horizontal test is not required.

(h) **Qualification test results.** A report of all tests for each design qualification, describing test setup, procedure and results must be submitted to the OHMT. This report must include at least the following basic information on each cylinder design tested.

#### BASIC CYLINDER DESIGN INFORMATION

##### Dimension, material and pressure data.

(Date) ..... \_\_\_\_\_  
 (Exemption number) ..... \_\_\_\_\_

Cylinder:

Service pressure ..... \_\_\_\_\_ PSIG  
 Volume ..... \_\_\_\_\_ cu. in.  
 Outside diameter of cylinder ..... \_\_\_\_\_ inches  
 Total weight of cylinder ..... \_\_\_\_\_ pounds  
 Auto-frettage pressure (Note 1) ..... \_\_\_\_\_ PSIG  
 Test pressure ..... \_\_\_\_\_ PSIG  
 Minimum prescribed burst pressure ..... \_\_\_\_\_ PSIG  
 Calculated burst pressure ..... \_\_\_\_\_ PSIG  
 Nominal thickness of overwrap ..... \_\_\_\_\_ inch  
 Minimum strand strength of filament ..... \_\_\_\_\_ psi  
 Minimum shear strength of resin ..... \_\_\_\_\_ psi  
 Weight of composite material ..... \_\_\_\_\_ pounds

Liner:

Weight of liner ..... \_\_\_\_\_ pounds  
 Inside diameter ..... \_\_\_\_\_ inches  
 Liner material and temper ... \_\_\_\_\_  
 Filament material ..... \_\_\_\_\_  
 Resin material ..... \_\_\_\_\_  
 Minimum wall thickness of liner (Qual. test cyl). \_\_\_\_\_ inch  
 Minimum design wall thickness of liner ..... \_\_\_\_\_ inch  
 Yield strength of liner (Qual. test cyl) ..... \_\_\_\_\_ psi  
 Minimum design yield strength of liner ..... \_\_\_\_\_ psi

Note 1. For each qualification test cylinder, the total and permanent volumetric expansion readings obtained in the auto-frettage pressurizations must be recorded.

**DESIGN STRESSES AND LOAD DISTRIBUTION**

	STRESS				LOAD	
	Direction		Distribution (psi)		Distribution (%)	
Pressure	Long.	Circ.	Liner	Overwrap	Liner	Overwrap
Zero	X	-		-		-
Service	-	X				

	X	-	-	-
Test	-	X		
*Minimum	X	-	-	-
Burst	-	X		

\*Based on §178.AA-7

(Insert Classification of TMDER Here) CLASSIFICATION: \_\_\_\_\_

NAVSEA/SPAWAR TECHNICAL MANUAL DEFICIENCY/EVALUATION REPORT (TMDER)				
<b>INSTRUCTION:</b> Continue on 8 - 1/2" x 11" paper if additional space is needed.				
1. USE THIS REPORT TO INDICATE DEFICIENCIES, PROBLEMS, AND RECOMMENDATIONS RELATING TO PUBLICATION. 2. FOR CLASSIFIED TMDERS, SEE OPNAVINST 5510H FOR MAILING CLASSIFIED TMDERS. 3. Submit TMDERS at web site <a href="http://nsdsa.phdnswc.navy.mil/">http://nsdsa.phdnswc.navy.mil/</a> or mail.				
1. PUB NO.  SS500-HK-MMO-010	2. VOL/PART	3. REV. NO./DATE OR TM CH. NO./DATE	4. SYSTEM/EQUIPMENT IDENTIFICATION	
5. TITLE Technical Manual, Operation and Maintenance Manual, Organizational Level, Lightweight Dive System (LWDS) MK 3 Mod 0			6. REPORT CONTROL NUMBER (UIC-YEAR-XXXX)	
7. RECOMMENDED CHANGES TO PUBLICATION				
PAGE NO. A.	PARA- GRAPH B.	C. RECOMMENDED CHANGES AND REASONS		
8. NAME AND WORK CENTER (Originator--Please Print)		9. DATE	10. DSN/COMM NO.	11. TRANSMITTED TO (NSDA Will Complete)
12. SHIP HULL NO. AND/OR STATION ADDRESS (Do Not Abbreviate)			13. EMAIL ADDRESS (Originator)	

-----  
FOLD HERE

DEPARTMENT OF THE NAVY

PLACE  
POSTAGE  
HERE

-----  
Official Business

COMMANDER  
NSDSA CODE 5E30  
NAVSURFWARCENDIV  
4363 MISSILE WAY  
PORT HUENEME, CA 93043-4307

-----  
FOLD HERE