



AD-A216 155

METHODOLOGY USED FOR GAS ANALYSIS AND CONTROL OF TRACE CHEMICAL CONTAMINANTS AT A HYPERBARIC FACILITY: 1. GAS SAMPLING

DTIC  
ELECTE  
DEC 26 1989  
S D D

- R. S. LILLO
- P. K. WEATHERSBY
- J. M. CALDWELL
- B. FRANKLIN
- E. T. FLYNN

Approved for public release;  
distribution is unlimited

Naval Medical Research  
and Development Command  
Bethesda, Maryland 20814-5044

Department of the Navy  
Naval Medical Command  
Washington, D.C. 20372-5210

89 12 22 001

## NOTICES

The opinions and assertions contained herein are the private ones of the writer and are not to be construed as official or reflecting the views of the naval service at large.

When U.S. Government drawings, specifications, or other data are used for any purpose other than a definitely related Government procurement operation, the Government thereby incurs no responsibility nor any obligation whatsoever, and the fact that the Government may have formulated, furnished or in any way supplied the said drawings, specifications, or other data is not to be regarded by implication or otherwise, as in any manner licensing the holder or any other person or corporation, or conveying any rights or permission to manufacture, use, or sell any patented invention that may in any way be related thereto.

Please do not request copies of this report from the Naval Medical Research Institute. Additional copies may be purchased from:

National Technical Information Service  
5285 Port Royal Road  
Springfield, Virginia 22161

Federal Government agencies and their contractors registered with the Defense Technical Information Center should direct requests for copies of this report to:

Defense Technical Information Center  
Cameron Station  
Alexandria, Virginia 22304-6145

## TECHNICAL REVIEW AND APPROVAL NMRI 88-92

The experiments reported herein were conducted according to the principles set forth in the current edition of the "Guide for the Care and Use of Laboratory Animals," Institute of Laboratory Animal Resources, National Research Council.

This technical report has been reviewed by the NMRI scientific and public affairs staff and is approved for publication. It is releasable to the National Technical Information Service where it will be available to the general public, including foreign nations.

KURT SORENSEN

CAPT MC USN

Commanding Officer  
Naval Medical Research Institute

## REPORT DOCUMENTATION PAGE

1a REPORT SECURITY CLASSIFICATION UNCLASSIFIED			1b RESTRICTIVE MARKINGS			
2a SECURITY CLASSIFICATION AUTHORITY			3 DISTRIBUTION/AVAILABILITY OF REPORT Approved for public release; distribution is unlimited			
2b DECLASSIFICATION/DOWNGRADING SCHEDULE			5 MONITORING ORGANIZATION REPORT NUMBER(S)			
4 PERFORMING ORGANIZATION REPORT NUMBER(S) NMRI-88-92			7a. NAME OF MONITORING ORGANIZATION Naval Medical Command			
2a NAME OF PERFORMING ORGANIZATION Naval Medical Research Institute		6b OFFICE SYMBOL (if applicable)		7b. ADDRESS (City, State, and ZIP Code) Department of the Navy Washington, DC 20372-5120		
5c ADDRESS (City, State, and ZIP Code) Bethesda, Maryland 20814-5055			9. PROCUREMENT INSTRUMENT IDENTIFICATION NUMBER			
2a NAME OF FUNDING/SPONSORING ORGANIZATION Naval Medical Research & Development Command		6b OFFICE SYMBOL (if applicable)		10. SOURCE OF FUNDING NUMBERS		
5c ADDRESS (City, State, and ZIP Code) Bethesda, Maryland 20814-5044			PROGRAM ELEMENT NO. 63713N	PROJECT NO. M0099	TASK NO. 01B	WORK UNIT ACCESSION NO. DN477506
11 TITLE (Include Security Classification) METHODOLOGY USED FOR GAS ANALYSIS AND CONTROL OF TRACE CHEMICAL CONTAMINANTS AT A HYPERBARIC FACILITY, I. GAS SAMPLING						
12 PERSONAL AUTHOR(S) Lillo, R.S., Weathersby, P.K.*, Caldwell, J.M., Franklin, B., and Flynn, E.T.						
13a TYPE OF REPORT Final		13b. TIME COVERED FROM 1984 TO 1988		14. DATE OF REPORT (Year, Month, Day) December 1988		15. PAGE COUNT 46
16 SUPPLEMENTARY NOTATION *Na. Submarine Medical Research Laboratory; Submarine Base, Box 900, Groton, CT 06349						
17 COSATI CODES			18. SUBJECT TERMS (Continue on reverse if necessary and identify by block number)			
FIELD	GROUP	SUB-GROUP	Diving, chemical contamination, gas analysis closed environment			
19 ABSTRACT (Continue on reverse if necessary and identify by block number)  The Naval Medical Research Institute (NMRI) currently conducts human hyperbaric research in a large pressure chamber complex originally installed in 1977. An early incident of organic chemical contamination demonstrated the need for a set of procedures for contaminant analysis, control, and removal that were appropriate for hyperbaric operations. Because such a comprehensive set of guidelines were nonexistent, the development of such methodology was undertaken. This has resulted in the establishment of a gas analysis laboratory in support of diving operations that insures the safety of the chamber atmosphere and gas supply for human diving experiments. This report describes one aspect of this program, that of gas sampling, at the Diving Medicine Department at NMRI. Sampling in this context refers to the collection of gas for subsequent chemical analysis. Because of the large potential for sampling error when working with trace hydrocarbon mixtures, correct gas sampling techniques are extremely important.						
20 DISTRIBUTION/AVAILABILITY OF ABSTRACT <input checked="" type="checkbox"/> UNCLASSIFIED/UNLIMITED <input type="checkbox"/> SAME AS RPT <input type="checkbox"/> DTIC USERS			21. ABSTRACT SECURITY CLASSIFICATION Unclassified			
22a NAME OF RESPONSIBLE INDIVIDUAL Phyllis Blum, Information Services Division			22b. TELEPHONE (Include Area Code) 202-295-2188		22c. OFFICE SYMBOL ISD/ADMIN/NMRI	

UNCLASSIFIED

SECURITY CLASSIFICATION OF THIS PAGE

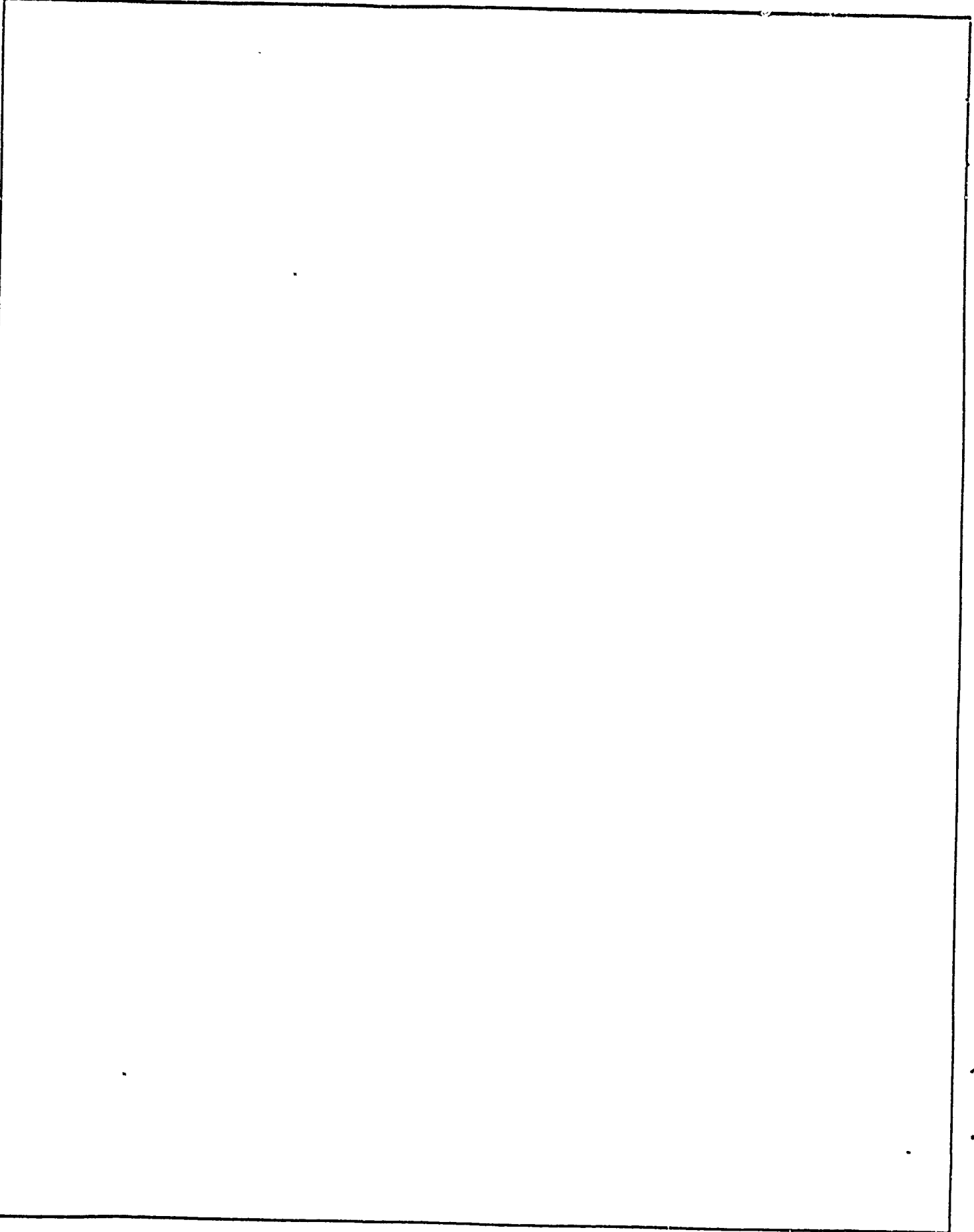

UNCLASSIFIED

SECURITY CLASSIFICATION OF THIS PAGE

ACKNOWLEDGEMENTS

The authors thank the following for their significant guidance during the early development of sampling procedures: W.D. Dorko of the National Bureau of Standards, Gaithersburg, MD and J.R. Wyatt of the Naval Research Laboratory, Washington, DC. A number of other people, particularly at the Environmental Protection Agency and Scott Specialty Gases, Plumsteadville, PA, also shared their expertise with NMRI so that gas sampling problems could be solved.

The authors also thank Mr. S. Hilleary for drawing the gas manifold and gas sampling schematics, and Ms. S. Cecire and Ms. J. Gaines for editorial assistance.

This study was funded by Naval Medical Research and Development Command Work Unit No. 63713N M0099.01B-1005. The opinions and assertions contained herein are the private ones of the authors and are not to be construed as official or reflecting the view of the United States Navy or the Naval Service at large.

This manuscript was prepared by United States Government employees as part of their official duties and, therefore, cannot be copyrighted and may be copied without restriction.

Accession For	
NTIS	<input checked="" type="checkbox"/>
DTIC TAB	<input type="checkbox"/>
Unannounced	<input type="checkbox"/>
Justification	
By _____	
Distribution/	
Availability Codes	
Dist	Avail and/or Special
A-1	



TABLE OF CONTENTS

	Page
ABSTRACT . . . . .	i
ACKNOWLEDGEMENTS . . . . .	iii
INTRODUCTION . . . . .	1
PRESENT SYSTEM . . . . .	2
I. Sampling Containers . . . . .	5
II. Stainless Steel Cylinder Preparation Procedures . . . . .	8
III. Regulators, Whips, and Connectors . . . . .	13
IV. Specialized Gas Sampling Equipment . . . . .	16
V. Cleaning and Testing of Items for Offgassing . . . . .	19
VI. Sampling Procedures . . . . .	24
CONCLUSIONS . . . . .	33
REFERENCES . . . . .	34

LIST OF TABLES

Table 1. Effectiveness of Stainless Steel Syringe in transferring trace hydrocarbon mixtures as measured by % Recovery . . . . .	35
Table 2. Effectiveness of Stainless Steel Cylinders in storage of trace hydrocarbon mixtures as measured by % Recovery . . . . .	36
Table 3. Effectiveness of Stainless Steel Bellows Pump in transferring trace hydrocarbon mixtures as measured by % Recovery . . . . .	37

APPENDICES

Appendix A. Gas Sampling Equipment . . . . .	38
Appendix B. Procedure: Purging a Regulator on a Gas Cylinder . . . . .	41

LIST OF FIGURES

Figure Legends . . . . .	42
Figure 1. Gas Sample Cylinder. . . . .	44
Figure 2. Vacuum Manifold System . . . . .	45
Figure 3. Gas Sample Assembly . . . . .	46

## INTRODUCTION

The Naval Medical Research Institute (NMRI) currently conducts hyperbaric research in a large pressure chamber complex known as the man-rated chamber complex (MRCC), which was originally installed in 1977. An early incident of organic chemical contamination (Weathersby et al., 1986) demonstrated the need for a set of procedures for contaminant analysis, control, and removal that were appropriate for hyperbaric operations. Because such a comprehensive set of guidelines was nonexistent, the development of such methodology was undertaken. During the initial development period, NMRI had little experience with such techniques. However, helpful guidance was provided by persons associated with the Naval Research Laboratory, Environmental Protection Agency, National Bureau of Standards, and Scott Specialty Gases. This effort has resulted in the establishment of a gas analysis laboratory in support of diving operations to insure the safety of the chamber atmosphere and gas supply for human diving experiments.

This report describes gas sampling, which is one aspect of NMRI's gas analysis program in the Diving Medicine Department (DMD). Sampling in this context refers to the collection of gas for subsequent chemical analysis. Because of the large potential for sampling error when working with trace hydrocarbon mixtures, correct gas sampling techniques are extremely important. Gas sampling is a broad topic that includes many varied techniques that can apply to many different sampling conditions. However, this report will limit itself to gas sampling as it pertains to the present gas analysis program at the DMD, NMRI. Detailed information on equipment used by DMD is presented in Appendix A. This report will provide sufficient information so that the gas sampling procedures and equipment can be duplicated elsewhere. Locally,

this information can serve as a guide to how to obtain reliable gas samples for subsequent chemical analysis.

#### PRESENT SYSTEM

An important requirement for performing gas analysis is the ability to sample the gas or atmosphere in a way that will prevent or minimize any change in the constituents during the sampling process. Because gas samples are often taken in a collection device at one location for subsequent analysis elsewhere, storage of the sample on a short- or long-term basis is an important consideration. Unfortunately, there is a great deal of potential for gas samples to be altered during sampling and storage (Gunderson and Anderson, 1979; Pellizzari et al., 1984).

Many chemicals tend to dissolve in or adsorb to the walls of sampling tubing or sampling containers. This is particularly true with many types of "soft" materials such as plastics, and natural and synthetic rubber (including Tygon). Even unclean metal or metal with minor imperfections on its surface may present problems. Such materials have the ability to absorb or adsorb chemicals that contact them and later to desorb or "offgas" the chemicals. These phenomena not only introduce the potential to reduce the level of chemicals in a gas sample (resulting in "false negative" readings) but also to add chemicals to the sample that were not initially present (resulting in "false positive" readings). Both types of errors are undesirable but are easily made, especially when dealing with trace levels of hydrocarbons or other chemicals in gases. With some chemicals (i.e., acid gases), it may be nearly impossible to collect gas samples in a reliable manner because even fairly inert materials such as glass and stainless steel can react with such gases causing changes in the initial composition.

In addition to the potential problems just mentioned, the materials making up the sampling equipment and storage containers may themselves be sources of offgassing. This situation is particularly true for many synthetic rubber materials where plasticizers are used in the manufacturing process. Any adhesives or epoxies that have been used to join component parts of sampling equipment are also potential contamination sources. **Dirty sampling equipment containing grease or other hydrocarbons, or equipment recently cleaned with industrial solvents may also introduce significant contamination into samples. Use of clean regulators, whips, valves, piping, and sample containers is, therefore, mandatory.** However, a worse problem may result from attempts to clean the components of the sampling system if care is not taken to insure that residues from cleaning agents have been removed from the items. Prior to putting into service equipment that has been exposed to cleaning solvents, offgassing of these chemicals can be facilitated by heating, evacuation, and/or purging with clean gas. Following these procedures, items should be kept clean during installation and use. In particular, fluorinated sealing greases, such as Krytox (DuPont Corp., Wilmington, DE), should not be used with any of the gas analysis equipment discussed here.

Clearly, much care must be taken during the gas sampling process to insure reliability and accuracy. The remainder of this report will, therefore, concentrate on the procedures and equipment used at the DMD for gas sampling. Six topics will be presented:

- I. Sampling Containers
- II. Stainless Steel Cylinder Preparation Procedures
- III. Regulators, Whips, and Connectors
- IV. Specialized Gas Sampling Equipment

## V. Cleaning and Testing of Items for Offgassing

## VI. Sampling Procedures

We have extensively tested the performance of much of this equipment and the reliability of these procedures. In this report, some of these test results will be very briefly presented to give the reader an idea of the effectiveness of the methodology. This necessitates that the analytical techniques used be briefly described here although a complete discussion of the analytical procedures developed by DMD will be left to a later report.

All analyses referred to in this report were done by gas chromatography (GC).

Fixed gas (i.e., O<sub>2</sub>, N<sub>2</sub>, He, CO<sub>2</sub>) analysis was performed with a Sigma-4 isothermic gas chromatograph with thermal conductivity detector (Perkin Elmer Corp., Norwalk, CT) using a column reversal procedure on molecular sieve 5A and Chromosorb 102 packed columns (Supelco Inc., Bellefonte, PA). Hydrocarbon analysis was performed on a Shimadzu GC-9A temperature programmable gas chromatograph with flame ionization detector (Shimadzu Corp., Columbia, MD). A methyl silicone packed column (SP-2100, Supelco Inc.) and a temperature ramp of 50-150 °C were used. In both cases, sample introduction was made using a gas sampling valve. All instruments were calibrated using gravimetric standards certified to ± 1-2% relative of stated value (Air Products and Chemicals, Inc., Allentown, PA; Scott Specialty Gases, Plumsteadville, PA). Quantitative precision associated with fixed gas analysis was < 1% relative; that associated with trace hydrocarbon analysis ranged from 1-5% relative, depending on the particular chemical.

The methodology presented in this report appears to work well for a number of specific hydrocarbons in concentrations > 0.1 ppm. The reliability of these procedures for hydrocarbon mixtures much below 1 ppm has not been demonstrated. Before use of any of these methods and/or equipment, their

effectiveness should be tested using gases similar to those that will be sampled.

### I. Sampling Containers

There is no universal agreement on what type of container is best for collection and storage of all types of gases under all conditions. The length of time that gas will be stored and the nature and concentration of the mixture will determine the suitability of various kinds of containers. Both stainless steel (Oliver et al., 1986) and aluminum cylinders have been used successfully for collection and both short-term (i.e., several hours) and long-term (i.e., several days to months) storage of gases with trace amounts (in the ppm range) of a variety of hydrocarbons and other chemicals. Often, the interior surfaces of stainless steel canisters are "passivated" by electropolishing. This procedure is thought to reduce the surface activity of the stainless steel and, thus, improve chemical stability of gas mixtures. Passivation appears to be especially important when working with very low concentrations of organics (i.e., ppb or ppt levels).

**For storage of trace hydrocarbon mixtures to be used as primary standards (i.e., calibration gases), the container of choice is aluminum cylinders.** The National Bureau of Standards has selected aluminum cylinders for many of their trace level hydrocarbons in gas mixtures which they provide as standard reference materials. Likewise, many commercial gas vendors supply hydrocarbon mixtures in aluminum cylinders. The prohibitive cost that would be associated with large stainless steel gas cylinders has effectively ruled out their commercial use for hydrocarbon standards. However, it is clear that even with aluminum, there are stability problems with particular hydrocarbons at particular concentrations. These problems are especially evident with some of the acid gases (personal communication, W. Dorko, National Bureau of

Standards). Three types of collection containers found by DMD to be appropriate for its applications are described below. Before use of any of these containers for gas sampling, their performance should be tested with gases similar to those that will be sampled. Testing should include not only checking stability during storage but also checking the ability to clean the container between samples.

a) Gas Sample Bags

For short-term storage of gas samples, collection bags have been widely used (Schuetzle et al., 1975). These are made out of materials such as Tedlar (polyvinyl fluoride) or Teflon (polytetrafluoroethylene), which are synthetic fluorinated polymers having relatively low permeability to gases. These materials are made without plasticizers to minimize offgassing from the bag itself. However, gas analysis experts disagree considerably on the suitability of these bags for gas sampling, especially when working with highly permeable gases such as helium, which can rapidly diffuse out of such bags. Although the gas permeability of these bags is low, they are not impermeable. For this reason, gas composition can change over time (i.e., over several hours). Tests reported by the EPA (Pellizzari et al., 1984) have demonstrated that bags filled with "clean" gas can be contaminated when stored in a dirty environment (i.e., a laboratory with a high level of hydrocarbons in the air). Even when used in conjunction with fixed gas analysis, storage of gas samples for an hour or more probably should be avoided. Because of these reasons, DMD does not routinely use these bags to collect gas for subsequent analysis of trace hydrocarbons. However, when no alternative is readily available, fixed gas samples have been taken by DMD using Tedlar bags (10 L, SKC Inc., Eighty-Four, PA), but analysis is always performed immediately (<15 min) after sample collection. In addition, Tedlar bags (10 L

and smaller) have been used by DMD for offgassing tests on small items before they are introduced into the MRCC; this application will be discussed later. Occasionally, analytical instruments in the laboratory have also been calibrated using mixtures of hydrocarbons that have been prepared using Tedlar bags. This latter application will not be further discussed in this report.

b) Stainless Steel Syringes

Another device that can be used for gas sample collection and short-term storage (several hours) is a stainless steel syringe (Scientific Instrumentation Specialists, Moscow, ID). These syringes use a highly inert, passivated stainless steel for the syringe barrel and sample contact surface construction. The only non-stainless material that comes in contact with the gas sample is the polyethylene slipper seal that is between the plunger and barrel. These characteristics insure that sample integrity will be maintained. Syringes can be obtained that have a standard luer connector end or a special shutoff valve. Stainless steel syringes provide a simple means to obtain a quick gas sample from a site at 1 ATA or to sample from a pressurized source via a pressure-reducing regulator. This sample can then be stored for several hours or easily transferred to analysis site. DMD has used these syringes (150 ml) successfully with fixed gases, as well as trace hydrocarbon gas mixtures (see Table 1). Even with trace hydrocarbon mixtures, gas samples have been found to be stable for at least several hours with no chemical memory remaining in the syringe after emptying. The advantages in using a stainless steel syringe are that gas samples can be easily taken without prior preparation of the sampling container and the filled syringe can be quickly transported to the site of analysis.

c) Stainless Steel Cylinders

For the majority of gas sampling from the MRCC, DMD presently uses

500 ml stainless steel sample cylinders (Whitey model 67, Whitey Co., Highland Heights, OH), pressure-rated at 1800 psi (see Fig. 1). These are fitted at both ends with Whitey brass, high-purity, shut-off valves via 1/4" male NPT fittings. A brass CGA 580 adapter with a 1/4" female NPT fitting is attached to one of the valves of each cylinder. This setup allows the cylinder to be directly connected to a CGA 580 nipple or to a 1/4" female NPT adapter. This permits direct attachment of a high purity regulator to the cylinder (via the CGA fitting) to control gas out-flow if the cylinder is filled at pressures much above 100 psig. DMD has demonstrated through testing that mixtures containing trace amounts of particular hydrocarbons can be stored over a number of months with excellent stability (see Table 2). These containers are readily prepared and cleaned by evacuation (see under "Stainless Steel Cylinder Preparation Procedures") and have shown no chemical traces of previous contents. Each cylinder has its own identification number stamped on its side as well as a metal identifying tag secured to the valve. Precise records are kept of its history including time and date of all procedures and a description of each gas introduced into the cylinder. These records facilitate solving of performance problems that might arise with any cylinder.

## II. Stainless Steel Cylinder Preparation Procedures

To enable accurate gas sampling, it is important that sample cylinders be free from any traces of previously introduced chemicals. Effective cylinder preparation should prevent chemicals of prior samples from contaminating or interfering in any way with the current gas sample. Depending on the method used for sampling, stainless steel cylinders ready for sampling may be under vacuum or at 1 ATA. Evacuated containers can be filled directly with gas. Non-evacuated containers have to be purged by flowing gas or filled under pressure, bled down to atmosphere, and refilled several times

in order to get an accurate sample. Cylinder preparation procedures used at the DMD are given below. However, the effectiveness of these procedures should be tested using gases that are similar to those that will be sampled.

**One method to verify cleanliness would be to perform the following test:**

1. Fill the cylinder with a hydrocarbon mixture representative of the sample gas by methods described under "Sampling Procedures."
2. Leave cylinder filled for several hours.
3. Vent the cylinder to the atmosphere and prepare cylinder for sampling as described below (i.e., non-evacuation or evacuation procedures).
4. Fill cylinder with a "zero" gas (i.e., hydrocarbon-free gas).
5. Leave cylinder filled for several hours.
6. Analyze this "zero" sample with appropriate analytical methods to determine if any hydrocarbon memory is present.

a) Non-evacuation Procedures

Non-evacuated cylinders that have been vented to 1 ATA require no other preparation prior to sample collection. However, it is important that the cylinder be clean and that all chemicals introduced into the cylinder from prior sampling be removed during the sampling process.

b) Evacuation Procedures

Use of evacuated cylinders simplifies sampling so that the cylinder can be filled directly without purging. Evacuation (under heating) is known to be very effective in cleaning cylinders and avoids potential problems with "sticky" compounds that can arise when non-evacuated cylinders are used. Thus, evacuated cylinders are preferred over non-evacuated cylinders. The system used by DMD for cylinder evacuation consists of a vacuum manifold to which the 500 ml stainless steel cylinders can be attached (see Fig. 2). This manifold also allows attachment of other equipment, thus allowing cleaning by

evacuation and heating of items such as regulators, whips, metal fittings, and adapters.

The vacuum manifold system (again see Fig. 2) consists of 4 principal components:

1. Standard mechanical vacuum pump (capable of drawing down to  $10^{-4}$  torr) with hydrocarbon trap and mist eliminator.
2. Thermocouple vacuum gauge and controller (capable of reading down to the millitorr range).
3. Manifold plumbing system (of stainless steel, copper, and brass) consisting of piping, valves, and appropriate adapters for connecting cylinders and other equipment.
4. "Zero" gas for backfilling sample cylinders including gas cylinder with hydrocarbon-free gas, high-purity regulator, and connections.

The vacuum pump allows for the pumping down of the cylinders to 30-60 millitorr. The main consideration in pump selection is adequate pumping capacity so that rapid evacuation of cylinders can be achieved. An Alcatel model ZM 2004A mechanical pump (Alcatel Vacuum Products, Hingham, MA) is used for the DMD system, which allows evacuation of up to eight 500 ml cylinders at one time in about 20 min. A trap is located between the pump and the manifold as close to the pump as possible in order to reduce the possibility of oil backstreaming and contaminating the system. Traps can also be employed to scrub out water when wet humid gas is being pumped, although this is not the purpose for use of a trap here. Suitable trap material for removing oil backstreaming include synthetic zeolites (13X molecular sieve) and activated alumina both of which will also absorb water and can be regenerated by heating. A mist eliminator is located on the exhaust port of the pump to

reduce the production of oil mist in the exhaust, which occurs primarily during cycling the system between atmospheric pressure and vacuum.

Vacuum of the manifold system is measured using a thermal conductivity vacuum gauge coupled to a controlling unit and direct-reading meter (Varian model 531 gauge tube and 804-A controller). Determination of vacuum is based on the principle that within certain limits the thermal conductivity of a gas is dependent upon its pressure. These gauges are generally accurate down to about 1 millitorr when properly calibrated and are used to insure that adequate evacuation has been achieved. DMD periodically calibrates its thermal conductivity gauges using a McLeod mercury vacuum gauge.

The manifold configuration permits sections of the piping to be connected to or isolated from vacuum so that cylinders or other equipment can be attached and removed from the system without disturbing the vacuum. Cylinders are attached to the manifold via CGA 580 brass nipples (with nuts) that are teflon tipped to aid sealing. Cylinders are first vented to the atmosphere to avoid exposing the vacuum pump to pressure and then attached to the manifold. Evacuation is started by opening the manifold valve to the particular cylinder. After the connection to the cylinder is found to be leak-tight (indicated by a low vacuum reading), the cylinder valve is opened. When full vacuum has been achieved, cylinders are heated gently with an electric heat gun to facilitate chemical desorption from the cylinder walls. This procedure works by raising the vapor pressures of chemicals, thus promoting offgassing. However, excessive heat has the potential for weakening the steel walls and lowering the pressure tolerance of the cylinder. To guard against this, the practice at DMD is to heat the cylinders so they are warm, but not hot, to touch (i.e., approximately 50 °C). The normal procedure in

cylinder preparation used by DMD is simple evacuation for at least 1/2 h followed by several minutes of heating and subsequent closure of the cylinder after it has cooled to laboratory temperature. The cylinder can then be removed for sampling. If cylinders are not immediately used for sampling, re-evacuation (with no additional heating) is performed for approximately 20 min prior to removal and subsequent sampling. This repeat evacuation acts as a backup to insure that only cylinders that are under a good vacuum are used for sampling. However, no evidence of leakage either under pressure or under vacuum has ever been observed with any of the cylinders.

In cases where difficulty is experienced in removing previously introduced chemicals from sample cylinders, evacuation can be followed by backfilling with a hydrocarbon-free gas to moderate pressures (i.e., 40 psi). A soak period of several hours is then recommended along with periodic heating. This is followed by depressurization, reevacuation, and heating. Cycling between a moderate vacuum and pressure is a commonly used procedure for cylinder cleaning in the compressed gas industry and is thought to be more effective than evacuation for cleaning. Evacuation essentially removes the gas from the cylinder that is present at the beginning but probably is not very effective in actual transport of offgassing chemicals after vacuum is reached. This is because so-called "viscous flow" (normal mass transport) of gas does not occur under vacuum conditions. Although application of vacuum should promote the offgassing process, actual removal of the desorbed chemicals may not be very effective. Soaking under pressure is also believed to assist in desorbing chemicals off surfaces. The need for these backfilling procedures has not arisen with the volatile compounds (i.e., Freons, toluene, xylene) that are typically in samples run at DMD.

### III. Regulators, Whips, and Connectors

Equipment used in gas analysis must be clean and produce minimal effect on the gas composition of samples or calibration gases in order to insure accuracy. These requirements are similar to those of sampling containers. To meet these requirements, not only are the materials of construction and design of the equipment important, but the cleanliness of such gas sampling items is essential.

Because of sample degradation problems, many types of materials should be avoided when selecting whips and connectors for gas sampling. In particular, most "soft" tubing and connectors made from synthetic rubber (i.e., Latex, Tygon, Buna) should not be used especially for trace hydrocarbon mixtures. For many fixed gas mixtures, these materials may work fairly well. "Hard" materials such as nylon or polyethylene may work in some situations for hydrocarbons although Teflon is a better choice because of its extreme inertness. When possible, DMD prefers to use all-metal (i.e., stainless steel, copper, brass) whips and connectors for gas sampling because of their high pressure tolerance and generally adequate inertness.

#### a) Regulators

In the case of DMD, gas samples are often taken from pressurized sources. In these instances, the source pressure often has to be reduced via a regulator to avoid over-pressurization of the sample container and/or to facilitate handling of the sample during the analysis phase. Likewise, use of a calibration gas mixture (i.e., primary gravimetric standard) requires that a regulator be attached to the cylinder.

There are many types and brands of regulators on the market, but not all are suitable for trace or high purity gas analysis work. An important factor in regulator selection is to insure that the gas media only comes in

contact with inert materials and that absorption of chemicals by the regulator or offgassing by its component materials is prevented or minimized. An area of major gas contact in the regulator is the diaphragm and the material of choice for this component is stainless steel. Stainless steel eliminates offgassing associated with elastomeric diaphragms and prevents chemical absorption; it also prevents diffusion of outside air through the diaphragm. Ideally, all seals and seats should be of material such as Teflon or Viton, which has low offgassing and permeability rates and is fairly inert. Such a regulator with a rigid metal diaphragm can be evacuated if it inadvertently becomes dirty through use (i.e., if a solvent or water is accidentally introduced into the regulator). However, with care, this type of regulator will stay clean and can be used with a wide range of gas analysis applications. For delivery of calibration gas to analytical instruments, these regulators should have relatively low delivery pressure ranges (i.e., 0-10, 0-25, 0-100 psi, the exact pressures depending on the application). Flow requirements for regulators would again depend on the particular situation. A number of manufacturers can supply these types of regulators, and 2 examples of ones used by DMD are given in the appendix. The examples provided are regulators that are used with cylinders of compressed gas rather than in-line regulators that are hard-piped into a gas delivery system.

b) Whips

Unless samples are taken directly from the atmosphere by opening the sample cylinder valve, some type of whip or connecting line is normally needed for sampling. This would generally be in addition to any regulator that is used. Direct attachment of sample cylinders to regulators is possible but usually awkward. Stainless steel 1/8" OD whips (3-6 foot in length) are routinely used by DMD for this purpose. A standard Swagelok connection on one

end of the whip allows mating with a connector either directly in line with the gas source or downstream of a high purity regulator. The other end of the whip is configured with a CGA 580 brass nipple and nut that mates with the female CGA 580 adapter of the cylinder. All whip parts are cleaned to O<sub>2</sub>-clean specifications (MIL-STD-1330C(SH), 1 Feb 1985), heated, evacuated, and purged with clean gas prior to being put into use to insure cleanliness.

c) Connectors

Metal adapters (stainless steel or brass) are commonly required to allow attachment of whips to sites where the 1/8" Swagelok fitting is not present. Frequently used adapters include: 1) 1/8" to 1/4" Swagelok and 2) 1/8" Swagelok to 1/4" pipethread. DMD also has adopted a standard connection for all regulator hookups to allow delivery of calibration gas to gas analysis equipment. The high purity regulators used at DMD normally have a 1/4" male pipethread end on the delivery side downstream of the flow control valve. An adapter (1/4" pipethread to 1/4" Swagelok) is attached to the regulator on the delivery side, which allows attachment of a male luer-lock connector (chrome-plated brass; Popper and Sons, New Hyde Park, NY) which has been welded to a 1/4" Swagelok fitting. Plastic (i.e., polyethylene) disposable 3-way stopcocks with luer ends can then be attached to the luer connector. This luer connector can subsequently be mated with any other gas line that has a luer connector simply by attaching 1 stopcock to another. Most connections associated with the DMD gas analysis system are of the luer type. Having one common connector type (i.e., luer connector) allows all lines and equipment to be attached to each other in easy fashion. As with the whips, all metal adapters are cleaned and heated before being put into use. All plastic 3-way stopcocks are used directly from the package; these stopcocks are exchanged daily with new ones to avoid potential contamination problems.

#### IV. Specialized Gas Sampling Equipment

There is some gas sampling equipment that is fairly unique to the field of trace gas analysis. This equipment includes specialized pumps, stainless steel syringes (discussed earlier), gas sample bags (discussed earlier), and chemical trapping agents. A brief discussion of the pumps and trapping agents as they apply to NMRI use will be presented.

##### a) Stainless Steel Bellows Pump

There is often the need to obtain a gas sample from a source that is at normal atmospheric pressure (1 ATA). These situations include times when contamination of the atmosphere is suspected within a given location (i.e., in a laboratory or hallway, or in the operational area surrounding the chamber complex). Another instance would be when the gas purity inside a piece of equipment needs to be checked and this item cannot be pressurized. Use of a stainless steel bellows pump (Metal Bellows Corp., Sharon, MA) allows pressurization of sample cylinders with gas from 1 ATA. These pumps contrast with typical ones that have internal parts (including bellows) made from synthetic materials such as Viton or Buna rubber. Bellows constructed from stainless steel are rigid and, therefore, use very small stroke volumes. Stainless steel bellows pumps must, therefore, operate at relatively high frequencies in order to move reasonable volumes of gas. Along with stainless steel, the gas that passes through these pumps comes in contact with the Teflon that makes up the valve gaskets. This Teflon is normally cleaned with Freon during the manufacturing process. However, to avoid potential offgassing problems with this solvent, DMD requested that Freon not be used to clean the Teflon in the pump that was purchased. The pump model that is used by DMD is capable of pressurizing a cylinder to 40 psi. Testing at DMD has demonstrated that mixtures of trace amounts of hydrocarbons can be effectively

handled by stainless steel pumps without contaminating them (see Table 3). DMD has equipped its pump with a brass CGA 580 nipple and nut on the output side and a support bracket so that its stainless steel cylinders can be directly attached and filled. A short (i.e., 1 ft) 1/4" stainless steel tube attached to the input side positions the gas intake at a short distance from the pump and permits attachment of a gas supply for testing purposes.

b) Trapping Material

Airborne contaminants can be monitored by collecting them on an adsorbent material (generally contained in a glass or metal tube). Sampling is accomplished by drawing or flowing a given amount of gas through the tube, which adsorbs a wide range of compounds. These tube samples can then be stored until analysis is possible. Desorption of the collected contaminants from the adsorbent is accomplished by using an appropriate solvent or, in the case of particular adsorbents, by heating. Samples can then be analyzed by gas chromatography. This method allows concentration of trace amounts of chemicals contained in gas samples. For quantitation, the specific volume of gas that passed through the trap must be known. Thermal desorption using adsorbents such as Tenax (a synthetic polymer) or a graphitized carbon material such as Carbotrap (Supelco, Inc.) allows the trap to be used repeatedly. These trapping/desorption techniques are widely used today, and the EPA has developed a number of standard methods employing this technology (Mosesman et al., 1988). Sampling gas using tubes containing trapping material has a number of advantages over sampling in pressured gas cylinders. For DMD's applications, these include the following:

1. A number of samples can be taken and stored in a relatively small space and transported easily to another site for analysis. For example,

a large number of samples could be taken on a submarine and transported to a shore-based laboratory for subsequent analysis.

2. Gas samples can be transported without using pressurized containers that are often restricted in certain modes of transport such as commercial airline service.

3. Concentration of trace amounts of chemicals increases the level of detectability and allows more accurate identification of chemical constituents. In fact, Gas Chromatography/Mass Spectrometry (GC/MS) analysis of unknowns generally requires higher concentrations of analytes compared to other analytical methods. This point is important and explains the rationale for the common use of chemical trapping/desorbing techniques with mass spectrometry for analysis of trace contaminants in air and water samples. DMD is currently using such a concentrating device (Tekmar Sample Concentrator Model LSC-2, Tekmar Co., Cincinnati, OH) when concentration of gas samples is necessary prior to introduction into its GC/MS system. This technique allows accurate gas analysis of trace contaminants during deep dives (i.e., 30-60 ATA). Normally, detection of 0.1 ppm of a hydrocarbon can be achieved with GC and several ppm with GC/MS using fairly standard procedures. The dilutional effect of depth can make it extremely difficult to detect chemicals in amounts as small as several ppm after correction for depth. For example, if the upper partial pressure exposure limit of 1 ppm (at 1 ATA) is used for benzene, then at a pressure of 30 ATA, this limit is reached when approximately 0.03 ppm is measured in the chamber gas with an analyzer at 1 ATA. Thus, depth becomes a confounding factor in the gas analysis problem that requires higher levels of detectability than normally would be needed. The disadvantage of using a gas concentrator is that additional procedures are required during the analysis process which, in turn, increases the error associated with the results.

## V. Cleaning and Testing of Items for Offgassing

In addition to testing of gas samples for purity, another large requirement for the DMD gas analysis laboratory is to insure that any item put into the MRCC does not contaminate its atmosphere or create an unsafe environment for divers. This potential problem is similar to that for any closed environmental system and procedures have been reported by others for testing offgassing (i.e., in submarine atmospheres; Demas and Greenberg, 1986). Thus, testing of items that will be put into closed environments needs to be performed in order to determine what, if any, chemicals they offgas into the atmosphere. Such testing done at NMRI consists of "soaking" the item(s) in a closed vessel at 1 ATA or under pressure after first certifying that the system (vessel + gas) is clean. Following a soak period, gas samples are taken and analyzed for trace hydrocarbons.

### a) Cleaning

Before testing equipment, all items that contain or may possibly contain oil, grease, or other hydrocarbon contamination should be thoroughly cleaned, if possible. When dealing with metal components with/without soft parts (i.e., "O" rings, gaskets, washers, valve packings, etc.), the easiest way to do this at a hyperbaric facility is to have it done by the people who do the hydrocarbon-free cleaning and certification (MIL-STD-1330C(SH), 1 Feb 1985). These procedures involve use of Freon and TSP (trisodium phosphate solution) for cleaning metal parts followed by analysis that certifies that the level of hydrocarbons in a solvent rinse of the item does not exceed some set limit (commonly several ppm). If such cleaning capabilities are not available, small metal components can be cleaned with methanol, Freon, or methyl chloroform by immersion, brushing, and/or sonication. Following this,

Items should be allowed to completely dry so that all of the solvent offgasses. This process can be aided by heating (i.e., with a heat gun) or heating in a vacuum oven. If necessary, these procedures may be done, in a well-ventilated hood to minimize inhalation of the chemical vapors.

Following cleaning of metal components, soft components are usually replaced by new ones as part of the rebuilding process. The best rule is probably to install the new "O" rings, gaskets, etc. straight from the package and make no attempt to clean them. Cleaning these items by use of solvents may make the situation worse as the solvents may be absorbed into the material resulting in offgassing problems later. For soft goods (diver masks, rubber and synthetic tubing, insulated wiring, etc.), cleaning with solvents probably only removes surface dirt (grease, oil, and other hydrocarbons) and does little with deeply absorbed chemicals unless items are soaked in the solvents, which should be avoided.

Obviously, many kinds of equipment may not be readily cleanable, and testing would then be performed on the item "as is."

#### b) Offgassing Testing

Two types of vessels have been used for offgassing testing. A small experimental hyperbaric chamber (internal volume, approximately 165 l) that has been stripped of all inside constituents (i.e., heating/cooling shields, wiring, plumbing, etc.) is normally used for relatively large items. Properly prepared Tedlar gas sample bags (10 l and smaller) are used for smaller items.

The large chamber (referred to hereafter as the "contamination test chamber" (CTC)) is configured with a large rotary vane mechanical vacuum pump (Leybold-Heraeus model D30A, Leybold-Heraeus Vacuum Products, Inc., Export, PA) capable of achieving an ultimate vacuum of  $3 \times 10^{-4}$  torr. As with the

sample cylinder vacuum manifold system, a trap (activated alumina) to prevent oil backstreaming and an exhaust filter to reduce oil mist are used with the pump. A gas cylinder of "zero gas" (commonly air or  $N_2$ ) that has been checked to be hydrocarbon-free and fitted with a high purity regulator is used to pressurize the CTC for soaking. Plumbing and valves (stainless steel, copper, and brass) are arranged to allow for selective pressurization, venting, and evacuation of the chamber. A pressure gauge on the chamber allows for pressure monitoring; the vacuum achieved during evacuation can be estimated using the regulator on the "zero gas" cylinder, which reads vacuum (in inches Hg) as well as pressure.

The procedures used with the CTC are briefly presented here. In the case where the CTC has been out of service for a time, a check of the "baseline" gas composition within the CTC is made to insure that the chamber is clean. Several cycles of pressurization and evacuation are performed to aid removal of ambient air by dilution and to facilitate any potential offgassing of the chamber. This is similar to the procedures previously described for sample cylinder cleaning except the vacuum here is not as great and the chamber here is not heated. The cycling procedure is followed by a soaking period at pressure (3-4 ATA) for 2-3 days. This pressure is appropriate to provide an adequate sample volume of chamber gas (using the 500 ml stainless steel cylinders), but avoids the large dilutional effect of greater pressures. Use of higher pressures would reduce the ability to detect trace amounts of chemicals in the gas. Following the initial soak, a gas sample is drawn for analysis to document baseline hydrocarbon levels. Following sampling, the chamber is depressurized and opened, items to be tested are inserted, and the chamber is closed again. The chamber is then cycled several times again between vacuum and pressure to remove outside air

and then left pressurized at 3-4 ATA for another 2-3 day soak period. Samples are then drawn from this "soak" gas. Results from subsequent sampling and analysis are then compared to baseline levels to determine offgassing of test items.

The exact conditions (time and pressure) used for offgassing testing are not important. It is important, however, that an accurate record be maintained of all procedures. It is also essential that conditions during CTC baseline testing be similar to those during testing with equipment inside the chamber. This will allow valid comparisons to be made between baseline and equipment tests. Further testing of additional items can proceed without another baseline verification if the chamber is used immediately after the first tests and offgassing from these tests was minimal. The time allowed for soaking may not be long enough to reach equilibration between the chamber atmosphere, and chamber and test objects. However, this length of time should be adequate to reveal significant offgassing. Items that are checked out as acceptable are removed and, if not immediately used, are inserted into or wrapped in double plastic bags and stored in a clean environment to reduce the possibility of subsequent contamination.

When using the CTC to test a number of objects together, there is the potential for cross-contamination. Some objects may pick up volatile chemicals from other objects that are being soaked together. This possibility probably only applies in the case of softgood items. Metal parts, piping, and other gear would present a relatively inert barrier to the majority of chemical vapors and, thus, cross-contamination should not be expected to be a problem. Adsorption of organics onto active sites of metal surfaces should be minimal. We recommend testing different categories of softgoods separately if significant offgassing is expected. Clearly, anytime that a number of

softgood items are tested together, the potential exists for contamination of clean items by dirty items during the test period. If a softgood soak test turns up positive, all items then become suspect and cannot be assumed safe for human use. This is because it will not be known when or under what conditions the absorbed chemicals might be released.

Use of Tedlar bags provides an effective means for testing small items because the gas volume surrounding the objects can be reduced by partial collapse of the bag. This decreases the time for equilibrium to occur between the gas phase and object although with short periods of soaking, equilibrium may not occur. The dilutional effect of a large amount of gas is also avoided using a smaller volume resulting in increased sensitivity to offgassing chemicals. Another good use of Tedlar bag testing is with items that are expected to be dirty. These items may give off strong odors or have been constructed using glues, epoxies, and/or solvents; thus, they are potential sources of offgassing hydrocarbons. Use of bags eliminates the possibility of contaminating the CTC, which has a number of sites that may absorb vapors including valves, the inside paint coating of the chamber, and gaskets that are between metal-to-metal connections. A chemical "memory" has been observed to develop in the CTC in several instances where items offgassed relatively high concentrations of particularly "sticky" chemicals such as toluene and xylene. Residual concentrations of several ppm of these aromatics were effectively removed by a combination of scrubbing the CTC with detergent and rinsing with water, followed by cycling a number of times between vacuum and pressure. Based on these experiences, Tedlar bag testing has been adopted as the method to be used in cases of suspect items whenever possible.

As recommended by the manufacturer, sample bags are prepared by filling and emptying them 3 times with hydrocarbon-free gas, which purges any

residual chemicals due to manufacturing from the new bags. The bags are then filled a fourth time and sampled after 24 h to provide a control. Following sampling, an incision is carefully made in the wall of the bag just large enough to allow the test object to be placed inside. The bag incision is then secured by twisting the bag wall together and wrapping it with a rubber band. Again, at least 24 h is waited before sampling. Analysis results are then compared to the control to judge the offgassing due to the object. More specific filling and emptying instructions for Tedlar bags are presented under the next section "Sampling Procedures."

Offgassing tests may provide important qualitative information regarding what chemicals may be given off by objects. Under conditions that do not insure that equilibrium has occurred between object and vapor, results may not allow strict prediction of the magnitude of potential contamination but may suggest whether objects are safe to use. For example, after several days of soaking an item in a small gas volume in a Tedlar bag, detection of only minute amounts (< 1 ppm) of relatively harmless chemicals would be interpreted as safe for use in the MRCC.

#### VI. Sampling Procedures

Sampling procedures will depend on the specific sample site from which gas is collected. Potential sample sites at DMD include: a cylinder of gas to be analyzed, a pressurized diving chamber, a Tedlar bag or small hyperbaric chamber used to test the offgassing of an item, or a laboratory area within the building. For trace hydrocarbon analysis, it is mandatory that the gas flow being sampled comes into contact only with clean hardware, which includes high purity regulators and valves, and materials that minimally affect the gas composition. For fixed gas analysis, it may be possible to achieve acceptable accuracy under less than ideal sampling conditions. Assuming that clean

hardware and collecting devices are used, sampling procedures are designed to avoid sample alteration either by introduction or removal of chemical constituents or introduction of air. Thus, a critical step in sampling is to remove all ambient gas from sample lines to prevent it from entering the sample cylinder.

Another important point related to accurate sampling involves correct use of regulators. Ideally, regulators used on gas cylinders should be purged before use so that all gas initially in the regulator is removed (this would be mainly air when a regulator has just been installed on a cylinder). Because of regulator design, merely flowing gas through a regulator may not quickly remove all the initial gas. Regulator purging involves cycling the regulator between pressure and 1 ATA to dilute out the initial gas and replace it with the sample or cylinder mixture. Such a procedure is very important when using a regulator to deliver a calibration standard from a gas cylinder for several reasons. First, cylinder regulators generally have pressure gauges with associated dead-end tubes, which are difficult to purge by flowing gas. Second, attempting to flush such a regulator with the calibration gas mixture using high flow rates and large volumes of gas would be wasteful, as well as inefficient. Third, without effective purging of the regulator, there is potential for contamination of the calibration mixture as gas in the regulator diffuses back into the cylinder. The effect of this process may be negligible especially when using permanent gas mixtures with large proportions of all components including  $N_2$  and  $O_2$ . However, with trace mixtures of hydrocarbons, or mixtures with low amounts of  $CO_2$  or mixtures without any  $N_2$  or  $O_2$ , contamination may be a problem. Frequent switching of regulators between different cylinders would increase the possibility for contamination. In the case of in-line regulators

without gauges that are permanently connected in a diving system, such purging probably is not necessary because the high flows should dilute out the initial gas fairly quickly. The detailed procedure for purging regulators used with gas cylinders is presented in Appendix B.

There are several different methods of sample collection depending on the pressure of the sample source and how the container is to be filled:

- a) Collection from a pressurized source via a collection line
- b) Collection from a pressurized source directly at pressure without a collection line
- c) Collection from a high pressure gas cylinder (i.e., calibration gas mixture or cylinder of contaminated or suspect gas)
- d) Collection from a source at 1 ATA.

These procedures utilize the previously discussed sample containers: stainless steel cylinders (evacuated and non-evacuated), gas sample bags, and stainless steel syringes. The following details each sample collection method and which container may be used.

a) Collection from a pressurized source via a collection line

This procedure involves filling a sampling container via a sampling line that may or may not have a regulator in series with it. The purpose of the regulator would be to step down the pressure to which the sampling line and container are exposed so that excessive pressures and flows can be avoided. Normally, if the source pressure is below 100 psi, sample collection can be handled without using a regulator. Above this pressure, a high purity regulator (of the type described earlier in the report) would be used to step down the pressure before flowing the gas through the line to the sample container. Obviously, a valve would be situated between the source and the collection container. The valve could be part of the regulator; where no

regulator is used, the valve would be part of the piping to which the sample line is attached. Such a valve should be a variable flow type rather than a simple on/off valve such as a ball valve to allow adequate flow control.

The first step in preparing for sampling would be to open the valve controlling the flow from the source and flush the line for enough time to allow removal of all initial gas from the line. This flushing also allows for equilibration of the source gas with the piping system through which it flows. Equilibration in this case would be between trace chemicals in the gas and the materials (i.e., metal, hard plastic, nylon, "O" rings) that contact the gas. This procedure is done to insure that the gas flowing from the sample line accurately represents the source gas. In the case where a regulator is in the line, the adjustment knob on the regulator should be turned to generate a moderate delivery pressure (i.e., 40 psi) and the outlet valve opened so that gas will flow through the sample line. The time required for flushing obviously depends on the total volume that is being flushed (which depends on the length and inside diameter of the tubing) and the flow rate. Sampling sites at DMD generally are configured such that gas from the source must flow through 1/8" and/or 1/4" stainless steel tubing that ranges from 5-30 ft in total length before reaching the sample site. A "rule of thumb" normally used in this situation is to flush lines at a high flow rate for several minutes (in other words, so the flow exiting the line can be easily heard; this is usually at a rate of 5-10 l/min or more.) This procedure should flush the system with at least 10-20 volumes of gas, adequately purging the line with source gas while reaching equilibrium.

1. Stainless Steel Cylinders

- Evacuated Cylinders (see Fig. 3)

- Filling an evacuated cylinder via a collection line is begun by

first connecting the CGA 580 brass nipple of the sample line to the matching CGA 580 female adapter of the cylinder. This step is done as gas is flowing from the line to insure that all air is purged from the cylinder fitting at the point of attachment. The cylinder valve is then slowly opened to avoid drawing outside air into the cylinder. Rapid opening of the valve has the potential for air contamination if the connection between the cylinder and the line is not absolutely leak-free. This air leakage could occur if the gas flow from the line does not fully supply the flow demand created by the cylinder vacuum upon rapid valve opening. In this case, the vacuum could draw outside air into the cylinder via the sample line/cylinder valve connection. When the cylinder is completely opened to the sample flow, time is then allowed for pressure equilibration between cylinder and line. For line pressures and flows recommended earlier (< 100 psi and at least 5-10 l/min), it would be reasonable to allow 30 sec for valve opening and another 60 sec for pressure equilibration. At the end of this time, the cylinder valve is secured, flow through the sample line stopped by securing the upstream valve, and cylinder disconnected. The filled cylinder can now be taken to the laboratory for analysis. If a second duplicate sample is to be taken, the gas flow can be left on as the first cylinder is disconnected from the sample line and the second cylinder is connected. DMD normally tries to fill the cylinders to approximately 40-100 psi when possible. The lower pressure limit insures an adequate amount of sample for analysis. The upper limit facilitates handling of the sample by avoiding excessive pressures that are unnecessary and that require a regulator to be attached to the cylinder during analysis.

#### Non-evacuated Cylinders

DMD normally does not use non-evacuated cylinders. However, at least 2 different procedures can be used to obtain a gas sample from a

pressurized site using non-evacuated cylinders. A cylinder with a valve on both ends can simply be flushed with gas so that all initial gas is swept out and the cylinder is filled with the sample gas. The outflow valve can then be secured, cylinder pressurized, and the inflow valve secured. For the previously recommended line pressures and flows, the flushing process should be performed for several minutes when using cylinders of similar volume to those at the DMD (i.e., 500 ml). It must be cautioned that, depending on a cylinder design, complete cylinder flushing may be difficult to achieve. Instead, "pockets" of trapped gas may develop in particular cylinders that can compromise sampling accuracy.

The flushing procedure just mentioned cannot be used with cylinders with only one valve or orifice. In these cases, a series of pressuring-depressuring cycles should be performed during sampling. This procedure serially dilutes the starting concentration in exponential fashion during consecutive cycles. The number of cycles necessary to to achieve effective sampling would be dependent on the magnitude of the filling pressure and the concentration level of the prior sample. The higher the pressure, the greater would be the dilutional effect of each cycle. The greater the prior concentration, the less effective each filling cycle would be in diluting the prior sample components. Again, for the previously recommended pressures and flows, 5-6 cycles should probably be adequate.

## 2. Gas Sample Bags

As mentioned earlier, DMD does not normally use gas sample bags to collect gas for analysis. This is particularly true for trace hydrocarbon analysis due to stability problems already discussed. However, DMD occasionally uses Tedlar gas bags to obtain gas for fixed gas measurements. All analysis is completed as quickly as possible (within 15 min of bag-

filling) to avoid sample degradation with time. The bags that have been used by DMD have a volume of 10 l (SKC Inc.) and come with two separate fittings: 1) a one-way hose/valve fitting that can be opened to fill the bag and then closed to secure the bag and 2) a fitting that has a nut containing a replaceable septum through which a gas sample can be drawn with a gas-tight syringe for GC analysis. The nut on this latter fitting can also be removed so that the bag can be emptied after filling to purge the bag prior to sampling. Current bags available from SKC, Inc. incorporate both fittings into 1 composite hose/valve/septum fitting.

For DMD procedures, gas is supplied to the bag through a Teflon or polyethylene (P.E. 320, 0.106 inch I.D., 0.138 inch O.D.; Clay Adams, Parsippany, NJ) sample line that is approximately 1 ft in length to allow for easy handling of the bag during sampling. The sample line is attached to the hose fitting with a short (1/2") length of tygon tubing (1/8" I.D., 1/4" O.D.) that is used as a "butt connector". This connector allows the metal fitting to be butted up against the sample line with minimal exposure of the gas to the tygon. The other end of the sample line is attached again using a 1/2" tygon "butt connector" to a polypropylene three-way stopcock with luer ends. The stopcock allows easy attachment of the bag to a luer connector that is configured at the line supplying the gas flow from the sample site. The sampling procedure is started with the one-way hose/valve fitting pulled out so that gas purges the tubing and exits through a hole in the hose/valve fitting but does not enter the bag. After a short flush (i.e., 15 s) of the flexible sample line, the valve is pushed into the bag starting the filling process. After filling is complete (the bag should not be overfilled as it can be damaged), the valve is pulled out stopping the fill process. Emptying the bag is done by completely collapsing it on a flat surface after removing

the septum nut. The nut is then replaced before filling again. Three cycles of filling/emptying are completed to purge out the bag. This not only insures that a reliable sample is obtained but also removes any residual chemicals due to manufacturing from new bags. The bag is then filled a fourth time for the final sample.

Once the sample is taken, a gas-tight syringe can be used to remove an aliquot of gas for analysis. In addition, DMD has made up a brass luer adapter that will screw onto the bag where the septum nut normally is. This adapter allows gas to be removed from the bag using a stainless steel syringe for introduction into a GC.

### 3. Stainless Steel Syringes

Stainless steel syringes (150 ml) are often used by DMD to take gas samples for both fixed gas as well as trace hydrocarbon analysis. A three-way plastic stopcock with luer ends is placed on the luer tip of the syringe to provide an on/off valve. This allows syringe attachment to sampling lines and to analytical instruments. A low-pressure gas stream (i.e., from a sample site or a gas cylinder that needs to be analyzed) is allowed to push the plunger outward, thus filling the syringe by positive pressure. This avoids accidental aspiration of outside air. The syringe is filled and emptied 3 times during purging. The sample is then taken on the fourth fill and stopcock closed. The syringe can then be used to introduce a gas sample for GC analysis.

#### b) Collection from a pressurized source directly at pressure without a collection line

##### 1. Stainless Steel Cylinders

###### Evacuated Cylinders

An effective method for obtaining a sample from a pressurized

diving chamber with men inside is to "lock" the cylinder into the chamber and have a diver open the cylinder to the inside atmosphere, close it, and then "lock" it out. This procedure avoids the potential problems associated with flowing a sample through the tubing, regulators, and valves during which the composition of the gas may be changed. Using this method, cylinders will be filled at the same absolute pressure that exists inside the hyperbaric chamber.

c) Collection from a high pressure gas cylinder

1. Stainless Steel Cylinders

Evacuated Cylinders

For filling of evacuated cylinders, DMD has adapted a high-purity regulator to allow direct connection to the sample cylinder. The outlet valve has been removed from the regulator and a CGA 580 brass nipple and nut installed in its place. Procedures similar to those used when sampling from a pressurized source using a collection line are then followed.

2. Gas Sample Bags and Stainless Steel Syringes

For filling of gas sample bags and stainless steel syringes, a high-purity regulator with a luer fitting on the delivery end is used. Procedures similar to those used when sampling from a pressurized source using a collection line are then followed.

d) Collection from a source at 1 ATA

1. Stainless Steel Cylinders

Evacuated Cylinders

Evacuated cylinders can be opened at a sample site (i.e., laboratory room, operations deck) to fill the cylinder with gas at 1 ATA for trace hydrocarbon analysis. This cylinder can then be pressurized with clean gas to allow delivery of a sample for analysis. DMD normally pressurizes

these cylinders with an additional 1 to 3 ATA of hydrocarbon-free gas, with the exact pressure depending on the volume of gas needed for analysis. This process dilutes the sample gas, so the filling pressure should be kept as low as possible. Several hours are then allowed for the gas to fully mix and achieve homogeneity before analysis.

## 2. Stainless Steel Syringes

Stainless steel syringes (150 ml) can be used to draw gas samples (i.e., room air) at 1 ATA for both permanent gas and trace hydrocarbon analysis. Gas can also be sampled from gas sample bags that are being used for offgassing tests or for fixed gas analysis. In both cases, the syringe is filled by manual withdrawal of the plunger (negative pressure filling). As before, sampling is done by performing 3 filling/emptying purging cycles followed by a fourth filling.

## CONCLUSIONS

Human diving operations at hyperbaric facilities require that the chamber atmosphere and gas supply be free of chemical contamination. To insure these safety requirements, an in-house laboratory should have the capability to accurately analyze for trace levels of hydrocarbons. Generally, the first step in the analysis process is the collection of a gas sample. Because of the great potential for alteration of the gas during sampling, it is extremely important that accurate methods for gas sampling be developed and followed. This report has described some of the sampling procedures used at NMRI that have been found to be reliable.

#### REFERENCES

1. Military Standard (MIL-STD-1330C(SH)). Cleaning and testing of shipboard oxygen, nitrogen and hydrogen gas piping systems. Naval Sea Systems Command, U.S. Navy. 1 Feb., 1985.
2. Demas, P. and Greenberg, M. Manual of procedures for chemical analysis of materials used in nuclear submarines. David W. Taylor Naval Ship Research and Development Center (Rep. DTNSRDC/SME-86/24). Bethesda, MD, 1986.
3. Gunderson, E.C. and Anderson, C.C. Development and validation of methods for sampling and analysis of workplace toxic substances. NIOSH (Publ. PB80-194574), Cincinnati, OH, 1979.
4. Mosesman, N.H., Betz, W.R., and Corman, S.D. Development of a new trapping system for purge-and-trap analysis of volatile organic compounds. LC-SC 6: 328-336, 1988.
5. Oliver, K.D., Fleil, J.D., and McCleenny, W.A., "Sample integrity of trace level volatile organic compounds in ambient air stored in summa polished canisters." Atmospheric Environment, Vol. 20, pp. 1403-1411, 1986.
6. Pellizzari, E.D., Gutknecht, W.F., Cooper, S., and Hardison, D. Evaluation of sampling methods for gaseous atmospheric samples. NTIS (EPA Publ. PB84-190735), Springfield, VA, 1984.
7. Schuetzle, D., Prater, T.J. and Ruddell, S.R., "Sampling and analysis of emissions from stationary sources I. Odor and total hydrocarbons." Journal of Air Pollution Control Association, Vol. 25, pp. 925-932, 1975.
8. Weathersby, P.K., Lillo, R.S., Flynn, E.T, Wyatt, J.R. and Dorko, W.D. Trace chemical contaminants in a new human pressure chamber. Naval Medical Research Institute (Rep. 86-54), Bethesda, MD, 1986.

Table 1. Effectiveness of Stainless Steel Syringe in transferring trace hydrocarbon mixtures as measured by % Recovery.

<u>Standard 1</u>		<u>Standard 2</u>	
<u>Chemical</u>	<u>% Recovery</u>	<u>Chemical</u>	<u>% Recovery</u>
Freon 113 (10.38 ppm)	100.0	Methane (9.47 ppm)	100.4
1,1,1 Trichloroethane (10.24 ppm)	100.3	Ethane (10.50 ppm)	99.8
Benzene (10.05 ppm)	100.9	Propane (9.27 ppm)	99.8
Toluene (10.45 ppm)	102.8	Butane (9.42 ppm)	99.6
m-,p-Xylene (7.53 ppm)	104.8	Pentane (9.35 ppm)	99.9
o-Xylene (3.38 ppm)	106.0	Hexane (9.20 ppm)	100.0

% Recovery compares GC analysis of two primary standards using stainless steel syringe loading of GC to analysis using direct loading from primary standard cylinder:

$$\% \text{ Recovery} = (\text{Syringe reading} / \text{Direct reading}) \cdot 100.0$$

Concentrations of primary standards used are given in parentheses. Recovery values are means based on 2 tests conducted on different days. Sample remained in stainless steel syringe < 5 min. Deviations from 100.0% are within instrument precision for these chemicals at these concentrations. Precision for toluene and xylenes less than other chemicals.

Table 2. Effectiveness of Stainless Steel Cylinders in storage of trace hydrocarbon mixtures as measured by % Recovery.

<u>Chemical</u>	<u>% Recovery</u>		
	<u>Storage Time (days)</u>		
	<u>6</u>	<u>148</u>	<u>264</u>
Freon 113 (10.38 ppm)	100.1	100.4	100.3
1,1,1 Trichloroethane (10.24 ppm)	101.1	99.8	100.7
Benzene (10.05 ppm)	99.0	100.3	101.5
Toluene (10.45 ppm)	98.3	100.1	101.8
m-,p-Xylene (7.53 ppm)	96.5	100.1	102.7
o-Xylene (3.38 ppm)	96.0	101.4	106.2

---

% Recovery compares GC analysis of 1 primary standard after storage in stainless steel sample cylinder to analysis of original primary standard:

$$\% \text{ Recovery} = (\text{Cylinder reading} / \text{Primary Standard reading}) \cdot 100.0$$

Concentrations of primary standard used are given in parentheses. Values are means of 2 GC determinations. Deviations from 100.0% are within instrument precision for these chemicals at these concentrations. Precision for toluene and xylenes less than other chemicals.

Table 3. Effectiveness of Stainless Steel Bellows Pump in transferring trace hydrocarbon mixtures as measured by % Recovery.

<u>Chemical</u>	<u>% Recovery</u>
Freon 113 (9.18 ppm)	96.5
1,1,1 Trichloroethane (9.16 ppm)	96.0
Benzene (9.04 ppm)	95.5
Toluene (9.48 ppm)	95.1
m-,p-Xylene (6.78 ppm)	94.5
o-Xylene (2.99 ppm)	94.4

% Recovery compares GC analysis of primary standard after transfer by a stainless steel bellows pump to analysis of original primary standard:

$$\% \text{ Recovery} = (\text{Pump reading} / \text{Primary standard reading}) \cdot 100.0$$

Concentrations of primary standard are given in parentheses. Transfer involved pressuring stainless steel sample cylinder to 40 psi with primary standard using stainless steel bellows pump. Recovery values are means based on 2 GC determinations of each of 2 pumping tests conducted on different days. Error associated with test procedures (including use of Tedlar bags for loading the pump) does not allow resolution of recovery values from 100.0%.

APPENDIX A

Gas Sampling Equipment

1. Stainless Steel Sampling Syringe

Scientific Instrumentation Specialists  
P.O. Box 8941  
Moscow, ID 83843 (208) 882-3860

- a) 150 ml (other sizes also available)
- b) luer tip fitting (also available with an integral sample valve)

2. Stainless Steel Bellows Pump

Metal Bellows Corp.  
1075 Providence Highway  
Sharon, MA 02067  
(617) 668-3050

- a) model MB-151
- b) delivery pressure rating up to 40 psig

3. Tedlar Sample Bags

SKC Inc.  
334 Valley View Road  
Eighty Four, PA 15330-9614  
(412) 941-9741

- a) PVF bags (polyvinyl fluoride)
- b) 2 mil thickness, 10 liter and smaller bags used by DMD  
(available in 1-100 liter volumes; 4 mil thick bags recently have become available)
- c) 1 composite hose/valve/septum fitting now available

4. Stainless Steel Sample Cylinders

Scott Specialty Gases  
Route 611  
Plumsteadville, PA 18949  
(215) 766-8861

- a) Whitey (Whitey Co., Highland Heights, OH) model 67 series
- b) 500 ml inside volume (other sizes available)
- c) pressure rating 1800 psig
- d) length = 14.0 inches
- e) O.D. = 2.0 inches
- f) average weight = 2.56 lbs.
- g) 1/4 inch female NPT connections in both ends of cylinder
- h) fabricated from stainless steel type 304

- i) Whitey (supplied by Scott Gases) brass 14DKM4 high purity shut-off valves (1/4" male NPT fitting on valve inlet and outlet) installed on each end of cylinder using Teflon tape to make leak-tight
  - j) brass female CGA 580/1/4" female NPT fitting attached to Whitey valve on one end of cylinder using Teflon tape
  - k) cylinder number engraved on cylinder outside wall
5. Vacuum Pump and Accessories used on Vacuum Manifold System (for Stainless Steel Cylinder evacuation)

Vacuum Pump

Alcatel Vacuum Products  
40 Pond Park Road  
Hingham, MA 02043  
(617) 749-8710

- a) model ZM 2004A mechanical vacuum pump
- b) NW25 intake and exhaust flanges
- c) ultimate vacuum 10<sup>-4</sup> torr
- d) 90 liters/min free air displacement
- e) Alcatel Foreline Trap (bakeable) - #PA-00501
- f) Alcatel Mist Eliminator (exhaust filter) - #PA-68316

Al2O3 Trap Material

Leybold-Heraeus Vacuum Products, Inc.  
5700 Mellon Road  
Export, PA 15632  
(412) 327-5700

- a) 2 liter cannister - #85410

Thermocouple Vacuum Gauge and Control

Varian Vacuum Products  
611 Hansen Way  
Palo Alto, CA 94303  
(800) 882-7426

- a) Thermocouple Gauge Control model 804-A
- b) Thermocouple Gauge Tube (actual sensor) - #531

6. Vacuum Pump and Accessories used on CTC Vacuum System (for offgassing testing)

Vacuum Pump

Leybold-Heraeus Vacuum Products, Inc.  
5700 Mellon Road  
Export, PA 15632  
(412) 327-5700

- a) model D30A dual-stage rotary vane pump
- b) KF40 intake and exhaust flanges
- c) ultimate vacuum  $3 \times 10^{-4}$  torr
- d) 760 liters/min free air displacement
- e) Leybold-Heraeus Foreline Trap (for Al2O3) - #85416
- f) Leybold-Heraeus Smoke Eliminator (exhaust filter) - #99-171-127
- g) Al2O3 trap material - 2 liter canister - #85410

7. High Purity Gas Cylinder Regulators - several sources

Air Products and Chemicals, Inc.

P.O. Box 1536

Washington, DC 20013

(301) 864-2345

- a) model #E12-K-C144B
- b) high purity, low flow, 2-stage, stainless steel diaphragm
- c) maximum delivery pressure = 50 psig
- d) maximum air flow = 25 scfh

Scott Specialty Gases

Route 611

Plumsteadville, PA 18949

(215) 766-8861

- a) model 14
- b) high purity, low flow, 2-stage, stainless steel diaphragm
- c) maximum delivery pressure = 50 psig
- d) maximum air flow = 25 scfh

8. Luer Connectors

Metal luer connector for welding to Swagelok connection

Popper and Sons, Inc.

300 Denton Avenue

New Hyde Park, NY 11040

(516) 248-0300

- a) chrome-plated brass connector - #6169
- b) 1/4-5/16 inch I.D. hose end to male luer needle lock

3-Way Polypropylene Stopcocks

Migada Co.

Suite 215

150 East Olive

3urbank, CA 91502

(818) 848-3880

- a) plastic 3-way stopcock with luer connections - #3 STP-S

## APPENDIX B

### Procedure: Purging a Regulator on a Gas Cylinder

This purge procedure involves 3 purge cycles followed by a final adjustment of the delivery pressure so that the cylinder is ready for use. Each purge cycle starts with: 1) the cylinder valve upstream of the regulator closed, 2) the outlet valve on the regulator closed, and 3) the delivery pressure control knob turned completely out, not transmitting pressure to the delivery side of the regulator. Each purge cycle involves a rapid opening and closing of the cylinder valve. This step is designed to deliver cylinder pressure to the regulator and is followed by full pressurization of the delivery side of the regulator using the pressure control knob. The regulator is then vented off to atmosphere by opening the outlet valve. This valve is then closed and the delivery pressure knob is backed off in preparation of a repeat of the cycle. Three complete cycles generally achieve the goal of effectively purging a regulator; exceptions would be where cylinder pressures are comparatively low (i.e., less than 300 psi). In these cases, effectiveness of the dilutional process may be reduced when purging with lower pressures so that more than 3 purge cycles would be necessary. Immediately following these 3 cycles, the valve upstream of the regulator is fully opened and the required delivery pressure dialed in; the gas cylinder is then ready to be used.

## FIGURE LEGENDS

Figure 1. Gas Sample Cylinder - Photograph of an actual Stainless Steel Cylinder (500 ml internal volume) used by DMD for gas sampling. Note 2 high-purity shut-off valves on each end and the brass CGA 580 adapter that is attached to one end.

Figure 2. Vacuum Manifold System - Schematic diagram of the vacuum manifold system used by NMRI for evacuation of Stainless Steel Cylinders and other equipment used for gas sampling:

### Key

- A Gas Bottle (hydrocarbon-free gas)
- B Regulator
- C Shut-Off Valve
- D Thermocouple Vacuum Sensor
- E Electrical Lead
- F Thermocouple Vacuum Gauge Meter
- G CGA Connection Male End
- H Gas Sample Cylinder
- J Luer Connector
- K Ball Valve
- L Trap
- M Vacuum Pump
- N Exhaust Filter

Figure 3. Gas Sample Assembly - Schematic diagram of a gas sampling configuration that allows filling of an evacuated Stainless Steel Cylinder from a pressurized gas source (sample gas) via a stainless steel collection line.

Key

- A Stainless Steel Cylinder
- B Stainless Steel Whip
- C Shut-Off Valve
- D Regulator
- E Ball Valve
- F CGA Connection Male End
- G Sample Gas Source
- H CGA Connection Female End

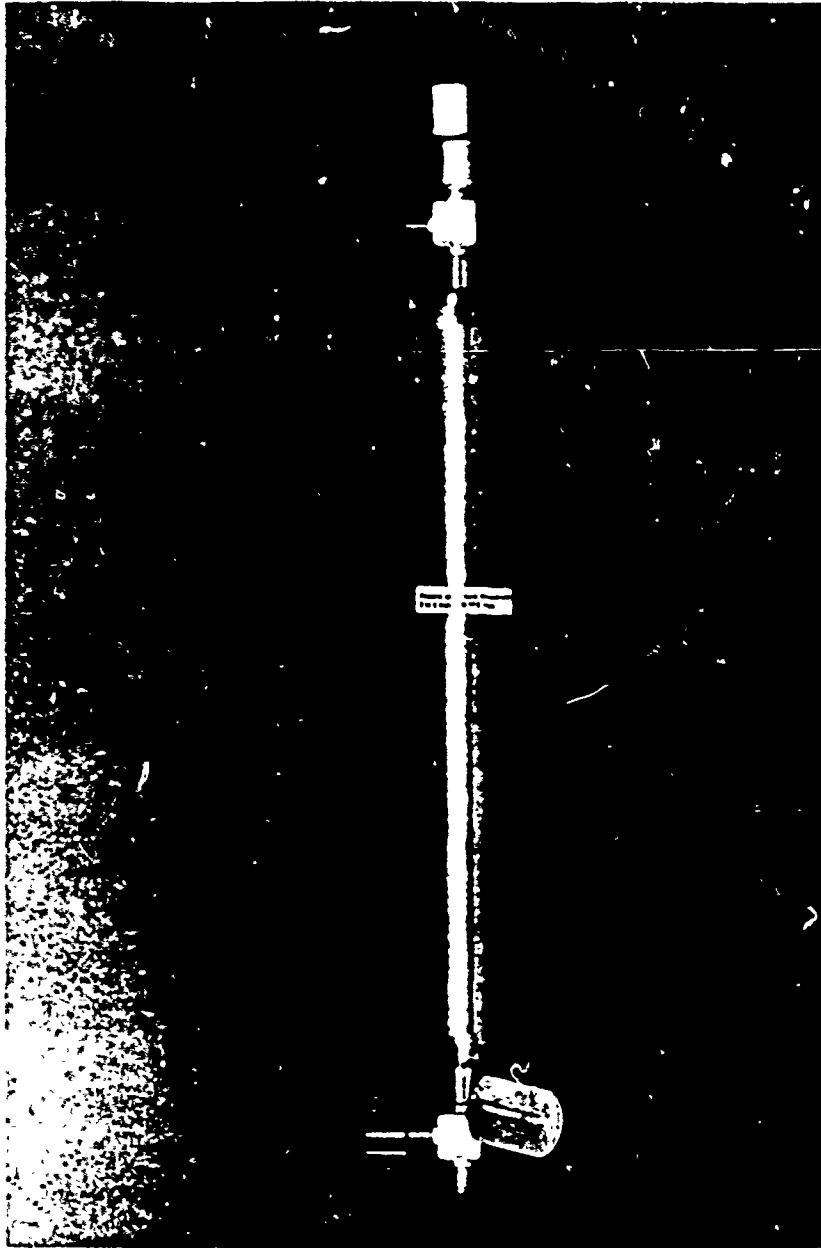

Figure 1

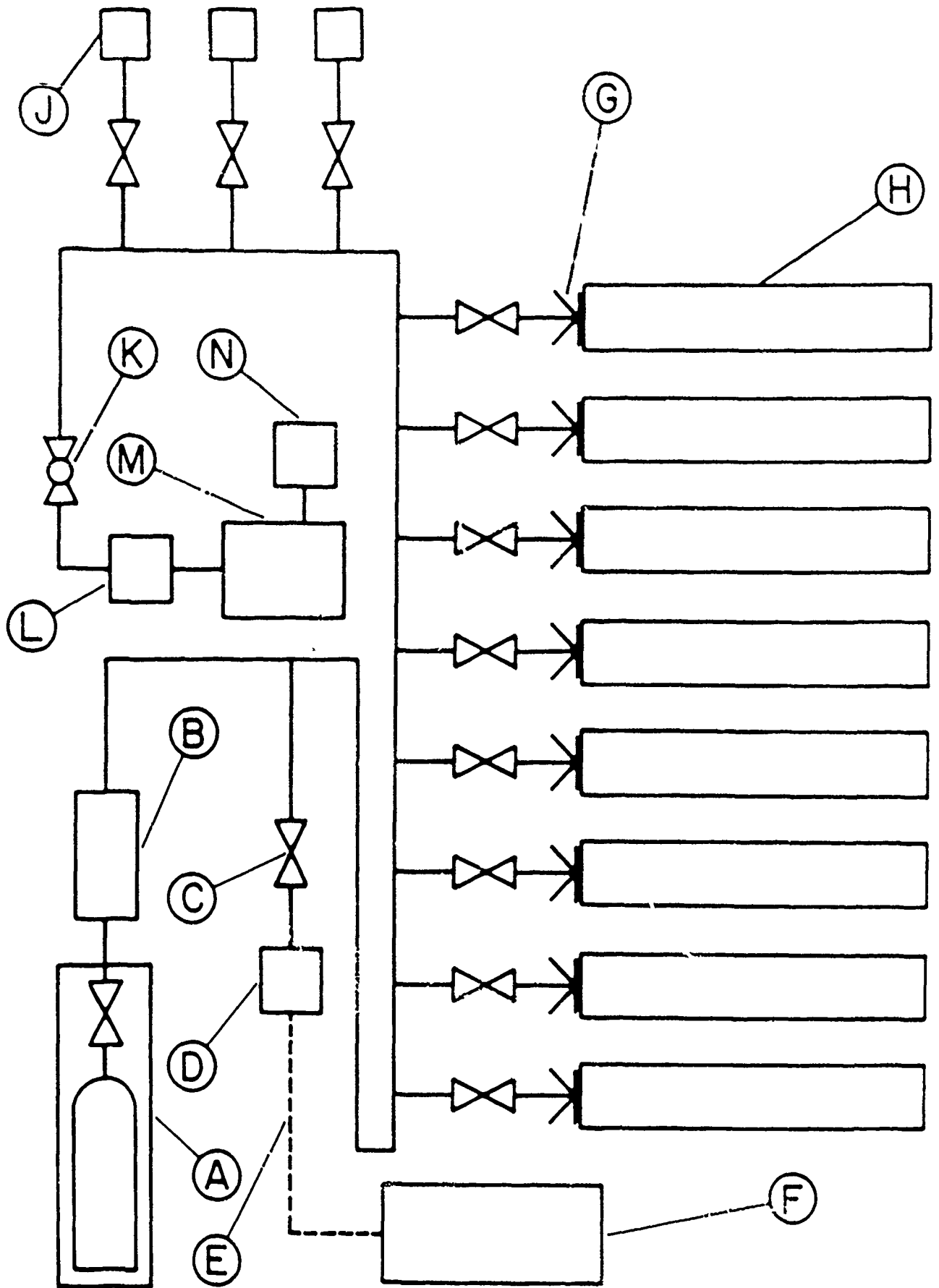
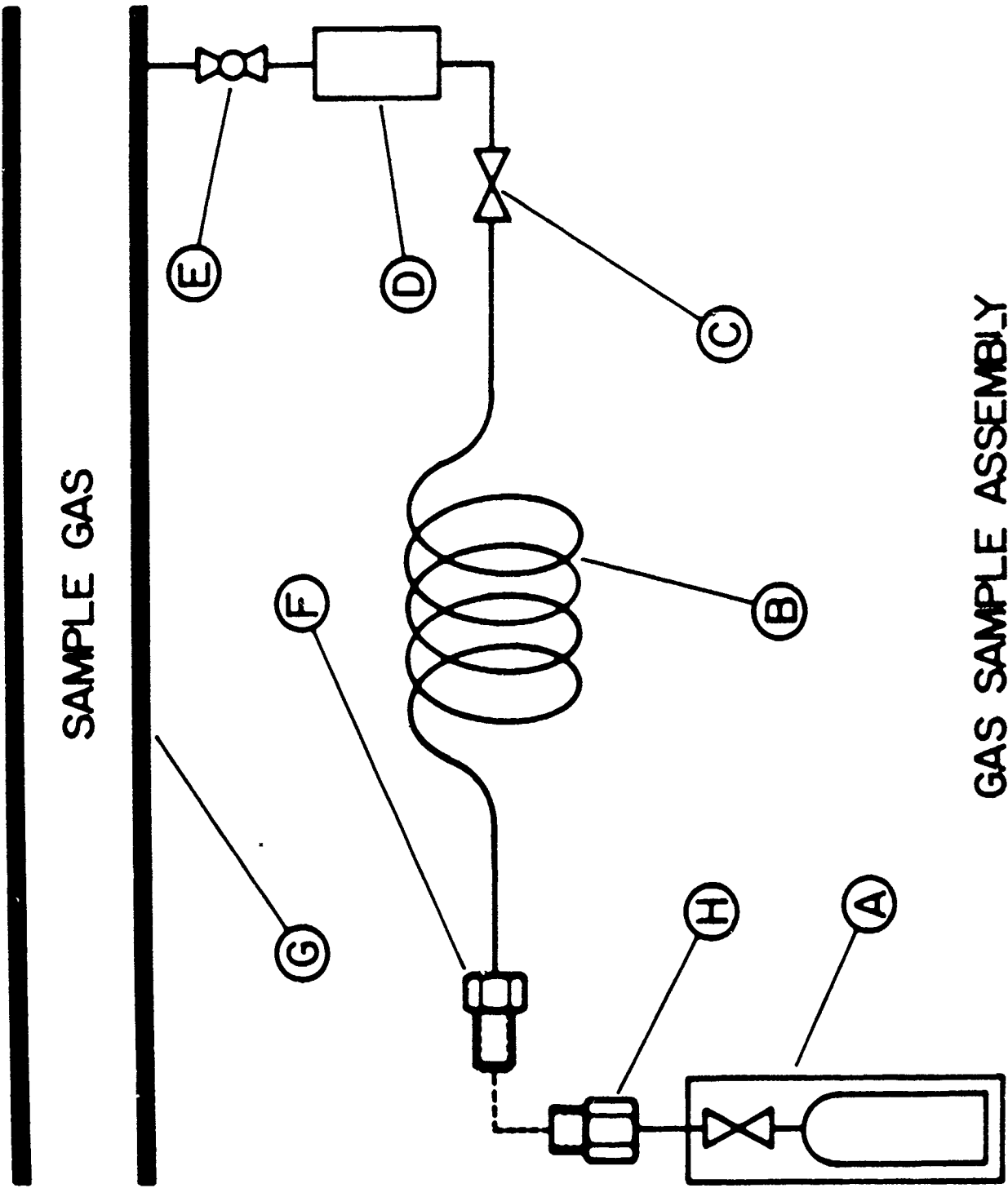

Figure 2



SAMPLE GAS

GAS SAMPLE ASSEMBLY

Figure 3